

MEASUREMENT REPORT

FCC PART 15.231(e) & RSS 210

FCC ID: TTETSB50
IC: 6707A-TSB50
APPLICANT: Suzhou Sate Auto Electronic Co., Ltd.
Application Type: Certification
Product: Tire Pressure Monitoring System Sensor
Model No.: TSB50
Brand Name: SATE
FCC Classification: FCC Part 15 Security/Remote Control Transmitter (DSC)
FCC Rule Part(s): Part 15.231(e)
IC Rule(s): RSS-210 Issue 9 - Annex A, RSS-GEN Issue 5
Test Procedure(s): ANSI C63.10-2013
Test Date: August 07 ~ 15, 2019

Reviewed By: 

(Sunny Sun)

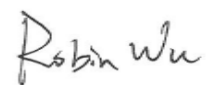
Approved By: 

(Robin Wu)



The test results relate only to the samples tested.

This equipment has been shown to be capable of compliance with the applicable technical standards as indicated in the measurement report and was tested in accordance with the measurement procedures specified in ANSI C63.10-2013. Test results reported herein relate only to the item(s) tested.

The test report shall not be reproduced except in full without the written approval of MRT Technology (Suzhou) Co., Ltd.

Revision History

Report No.	Version	Description	Issue Date	Note
1907RSU046-U1	Rev. 01	Initial Report	08-22-2019	Valid

CONTENTS

Description	Page
1. INTRODUCTION	6
1.1. Scope	6
1.2. MRT Test Location	6
2. PRODUCT INFORMATION.....	7
2.1. Equipment Description	7
2.2. EUT Setup and Test Mode.....	7
2.3. Test Configuration	7
2.4. EMI Suppression Device(s)/Modifications.....	7
2.5. Labeling Requirements	8
3. DESCRIPTION OF TEST	9
3.1. Evaluation Procedure	9
3.2. AC Line Conducted Emissions.....	9
3.3. Radiated Emissions.....	10
4. ANTENNA REQUIREMENTS	11
5. TEST EQUIPMENT CALIBRATION DATA	12
6. MEASUREMENT UNCERTAINTY	13
7. TEST RESULT	14
7.1. Summary	14
7.2. Conducted Emission	15
7.2.1. Test Limit	15
7.2.2. Test Setup	15
7.2.3. Test Result.....	15
7.3. Radiated Emissions.....	16
7.3.1. Standard Applicable.....	16
7.3.2. Test Setup	19
7.3.3. Test Results	20
7.4. 20dB & 99% Bandwidth.....	23
7.4.1. Standard Applicable.....	23
7.4.2. Test Procedure	23
7.4.3. Test Setup	23
7.4.4. Test Result.....	24
7.5. Transmission Time	26
7.5.1. Standard Applicable.....	26

7.5.2. Test Procedure26

7.5.3. Test Setup26

7.5.4. Test Result.....27

8. CONCLUSION.....30

Appendix A - Test Setup Photograph.....31

Appendix B - EUT Photograph32

§2.1033 General Information

Applicant:	Suzhou Sate Auto Electronic Co., Ltd.
Applicant Address:	No.36 Building, Yangtai Road, Suzou Industrial Park, Suzhou, Jiangsu, P.R.China
Manufacturer:	Suzhou Sate Auto Electronic Co., Ltd.
Manufacturer Address:	No.36 Building, Yangtai Road, Suzou Industrial Park, Suzhou, Jiangsu, P.R.China
Test Site:	MRT Technology (Suzhou) Co., Ltd
Test Site Address:	D8 Building, No.2 Tian'edang Rd., Wuzhong Economic Development Zone, Suzhou, China

Test Facility / Accreditations

Measurements were performed at MRT Laboratory located in Tian'edang Rd., Suzhou, China.

- MRT facility is a FCC registered (MRT Reg. No. 893164) test facility with the site description report on file and has met all the requirements specified in ANSI C63.4-2014.
- MRT facility is an IC registered (MRT Reg. No. 11384A-1) test laboratory with the site description on file at Industry Canada.
- MRT facility is a VCCI registered (R-20025, G-20034, C-20020, T-20020) test laboratory with the site description on file at VCCI Council.
- MRT Lab is accredited to ISO 17025 by the American Association for Laboratory Accreditation (A2LA) under the American Association for Laboratory Accreditation Program (A2LA Cert. No. 3628.01) in EMC, Telecommunications, Radio and SAR testing.



1. INTRODUCTION

1.1. Scope

Measurement and determination of electromagnetic emissions (EMC) of radio frequency devices including intentional and/or unintentional radiators for compliance with the technical rules and regulations of the Federal Communications Commission and the Industry Canada Certification and Engineering Bureau.

1.2. MRT Test Location

The map below shows the location of the MRT LABORATORY, its proximity to the Taihu Lake. These measurement tests were conducted at the MRT Technology (Suzhou) Co., Ltd. Facility located at D8 Building, No.2 Tian'edang Rd., Wuzhong Economic Development Zone, Suzhou, China. The measurement facility compliant with the test site requirements specified in ANSI C63.4-2014.



2. PRODUCT INFORMATION

2.1. Equipment Description

Product Name	Tire Pressure Monitoring System Sensor
Model No.	TSB50
Frequency Range	433.92MHz, 315MHz
Type of modulation	ASK & FSK Modulation for 433.92MHz ASK & FSK Modulation for 315MHz
Antenna Gain	0dBi

2.2. EUT Setup and Test Mode

The EUT was operated at continuous transmitting mode that was for the purpose of the measurements. All testing shall be performed under maximum output power condition, and to measure its highest possible emissions level, more detailed description as follows:

Test Mode	Description	Remark
Mode 1	Transmitting	With 433.92MHz ASK Modulation
Mode 2	Transmitting	With 433.92MHz FSK Modulation
Mode 3	Transmitting	With 315MHz ASK Modulation
Mode 4	Transmitting	With 315MHz FSK Modulation

2.3. Test Configuration

The EUT was tested as described in this report is compliance with the requirements limits of FCC Rules Part 15.207,15.209, 15.215 and 15.231. ANSI C63.10-2013 was used to reference the appropriate EUT setup for radiated spurious emissions testing and AC line conducted testing.

2.4. EMI Suppression Device(s)/Modifications

No EMI suppression device(s) were added and/or no modifications were made during testing.

2.5. Labeling Requirements

Per 2.1074 & 15.19; Docket 95-19

The label shall be permanently affixed at a conspicuous location on the device; instruction manual or pamphlet supplied to the user and be readily visible to the purchaser at the time of purchase.

However, when the device is so small wherein placement of the label with specified statement is not practical, only the FCC ID must be displayed on the device per Section 15.19(a)(5). Please see attachment for FCC ID label and label location.

RSP-100 Issue 11 Section 3

The manufacturer, importer or distributor shall meet the labeling requirements set out in this section for every unit:

- (i) prior to marketing in Canada, for products manufactured in Canada
- (ii) prior to importation into Canada, for imported products

For information regarding the e-labeling option, see Notice 2014–DRS1003. The label for the certified product represents the manufacturer’s or importer’s compliance with Innovation, Science and Economic Development Canada’s (ISED) regulatory requirements.

Please see attachment for IC label and label location.

3. DESCRIPTION OF TEST

3.1. Evaluation Procedure

The measurement procedures described in the American National Standard for Testing Unlicensed Wireless Devices (ANSI C63.10-2013), and the requirements provided in FCC 15.207, 15.209, 15.215 and 15.231 were performed in the report of the EUT.

Deviation from measurement procedure.....None

3.2. AC Line Conducted Emissions

The line-conducted facility is located inside an 8'x4'x4' shielded enclosure. A 1m x 2m wooden table 80cm high is placed 40cm away from the vertical wall and 80cm away from the sidewall of the shielded room. Two 10kHz-30MHz, 50Ω/50uH Line-Impedance Stabilization Networks (LISNs) are bonded to the shielded room floor. Power to the LISNs is filtered by external high-current high-insertion loss power line filters. These filters attenuate ambient signal noise from entering the measurement lines. These filters are also bonded to the shielded enclosure.

The EUT is powered from one LISN and the support equipment is powered from the second LISN. All interconnecting cables more than 1 meter were shortened to a 1 meter length by non-inductive bundling (serpentine fashion) and draped over the back edge of the test table. All cables were at least 40cm above the horizontal reference ground-plane. Power cables for support equipment were routed down to the second LISN while ensuring that that cables were not draped over the second LISN.

Sufficient time for the EUT, support equipment, and test equipment was allowed in order for them to warm up to their normal operating condition. The RF output of the LISN was connected to the receiver and exploratory measurements were made to determine the frequencies producing the maximum emission from the EUT. The receiver was scanned from 150 kHz to 30 MHz. The detector function was set to peak mode for exploratory measurements while the bandwidth of the analyzer was set to 9 kHz. The EUT, support equipment, and interconnecting cables were arranged and manipulated to maximize each emission. Each emission was also maximized by varying: power lines, the mode of operation or data exchange speed, or support equipment whichever determined the worst-case emission. Once the worst-case emissions have been identified, the one EUT cable configuration/arrangement and mode of operation that produced these emissions are used for final measurements on the same test site. The analyzer is set to CISPR quasi-peak and average detectors with a 9 kHz resolution bandwidth for final measurements.

An extension cord was used to connect to a single LISN which powered by EUT. The extension cord was calibrated with LISN, the impedance and insertion loss are compliance with the requirements as stated in ANSI C63.10-2013.

3.3. Radiated Emissions

The radiated test facilities consisted of an indoor 3 meter semi-anechoic chamber used for final measurements and exploratory measurements, when necessary. The measurement area is contained within the semi-anechoic chamber which is shielded from any ambient interference. For measurements above 1GHz absorbers are arranged on the floor between the turn table and the antenna mast in such a way so as to maximize the reduction of reflections. For measurements below 1GHz, the absorbers are removed. A MF Model 210SS turntable is used for radiated measurement. It is a continuously rotatable, remote controlled, metallic turntable and 2 meters (6.56 ft.) in diameter. The turn table is flush with the raised floor of the chamber in order to maintain its function as a ground plane. An 80cm high PVC support structure is placed on top of the turntable.

For all measurements, the spectrum was scanned through all EUT azimuths and from 1 to 4 meter receive antenna height using a broadband antenna from 30MHz up to the upper frequency shown in 15.33(b)(1) depending on the highest frequency generated or used in the device or on which the device operates or tunes. For frequencies above 1GHz, linearly polarized double ridge horn antennas were used. For frequencies below 30MHz, a calibrated loop antenna was used. When exploratory measurements were necessary, they were performed at 1 meter test distance inside the semi-anechoic chamber using broadband antennas, broadband amplifiers, and spectrum analyzers to determine the frequencies and modes producing the maximum emissions. Sufficient time for the EUT, support equipment, and test equipment was allowed in order for them to warm up to their normal operating condition. The test set-up for frequencies below 1GHz was placed on top of the 0.8 meter high, 1 x 1.5 meter table; and test set-up for frequencies 1-25GHz was placed on top of the 1.5 meter high, 1 x 1.5 meter table. The EUT, support equipment, and interconnecting cables were arranged and manipulated to maximize each emission. Appropriate precaution was taken to ensure that all emissions from the EUT were maximized and investigated. The system configuration, clock speed, mode of operation or video resolution, if applicable, turntable azimuth, and receive antenna height was noted for each frequency found.

Final measurements were made in the semi-anechoic chamber using calibrated, linearly polarized broadband and horn antennas. The test setup was configured to the setup that produced the worst-case emissions. The spectrum analyzer was set to investigate all frequencies required for testing to compare the highest radiated disturbances with respect to the specified limits. The turntable containing the EUT was rotated through 360 degrees and the height of the receive antenna was varied 1 to 4 meters and stopped at the azimuth and height producing the maximum emission. Each emission was maximized by changing the orientation of the EUT through three orthogonal planes and changing the polarity of the receive antenna, whichever produced the worst-case emissions.

According to 3dB Beam-Width of horn antenna, the horn antenna should be always directed to the EUT when rising height.

4. ANTENNA REQUIREMENTS

Excerpt from §15.203 of the FCC Rules/Regulations:

“An intentional radiator antenna shall be designed to ensure that no antenna other than that furnished by the responsible party can be used with the device. The use of a permanently attached antenna or of an antenna that uses a unique coupling to the intentional radiator shall be considered sufficient to comply with the provisions of this section.”

- The antenna of the unit is permanently attached.
- There are no provisions for connection to an external antenna.

Conclusion:

The unit complies with the requirement of §15.203.

5. TEST EQUIPMENT CALIBRATION DATA

Conducted Emissions - SR2

Instrument	Manufacturer	Type No.	Asset No.	Cali. Interval	Cali. Due Date
EMI Test Receiver	R&S	ESR3	MRTSUE06185	1 year	2020/04/15
Two-Line V-Network	R&S	ENV 216	MRTSUE06002	1 year	2020/06/13
Two-Line V-Network	R&S	ENV 216	MRTSUE06003	1 year	2020/06/13
Thermohygrometer	Testo	608-H1	MRTSUE06404	1 year	2020/08/08
Shielding Room	MIX-BEP	Chamber-SR2	MRTSUE06215	N/A	N/A

Radiated Emissions - AC1

Instrument	Manufacturer	Type No.	Asset No.	Cali. Interval	Cali. Due Date
EMI Test Receiver	R&S	ESR7	MRTSUE06001	1 year	2020/08/01
PXA Signal Analyzer	Keysight	9030B	MRTSUE06395	1 year	2019/09/25
Loop Antenna	Schwarzbeck	FMZB 1519	MRTSUE06025	1 year	2019/11/09
Bilog Period Antenna	Schwarzbeck	VULB 9168	MRTSUE06172	1 year	2020/03/31
Broad Band Horn Antenna	Schwarzbeck	BBHA 9120D	MRTSUE06023	1 year	2019/10/19
Broad Band Horn Antenna	Schwarzbeck	BBHA 9170	MRTSUE06024	1 year	2019/12/17
Microwave System Amplifier	Agilent	83017A	MRTSUE06076	1 year	2019/11/16
Preamplifier	Schwarzbeck	BBV 9721	MRTSUE06121	1 year	2020/06/11
Thermohygrometer	Testo	608-H1	MRTSUE06403	1 year	2020/08/08
Anechoic Chamber	TDK	Chamber-AC1	MRTSUE06212	1 year	2020/04/30

Radiated Emission - AC2

Instrument	Manufacturer	Type No.	Asset No.	Cali. Interval	Cali. Due Date
Spectrum Analyzer	Keysight	N9038A	MRTSUE06125	1 year	2020/08/01
Loop Antenna	Schwarzbeck	FMZB 1519	MRTSUE06025	1 year	2019/11/09
Bilog Period Antenna	Schwarzbeck	VULB 9162	MRTSUE06022	1 year	2019/10/19
Horn Antenna	Schwarzbeck	BBHA9120D	MRTSUE06171	1 year	2019/11/09
Broad Band Horn Antenna	Schwarzbeck	BBHA 9170	MRTSUE06024	1 year	2019/12/17
Broadband Coaxial Preamplifier	Schwarzbeck	BBV 9718	MRTSUE06176	1 year	2019/11/16
Preamplifier	Schwarzbeck	BBV 9721	MRTSUE06121	1 year	2020/06/11
Temperature/Humidity Meter	Minggao	ETH529	MRTSUE06170	1 year	2019/12/13
Anechoic Chamber	RIKEN	Chamber-AC2	MRTSUE06213	1 year	2020/04/30

Software	Version	Function
e3	V8.3.5	EMI Test Software

6. MEASUREMENT UNCERTAINTY

Where relevant, the following test uncertainty levels have been estimated for tests performed on the EUT as specified in CISPR 16-4-2. This uncertainty represents an expanded uncertainty expressed at approximately the 95% confidence level using a coverage factor of $k = 2$.

Conducted Emission Measurement - SR2	
The maximum measurement uncertainty is evaluated as:	
9kHz~150kHz: 3.84dB	
150kHz~30MHz: 3.46dB	
Radiated Emission Measurement - AC1	
The maximum measurement uncertainty is evaluated as:	
Horizontal: 30MHz~300MHz: 4.07dB	
300MHz~1GHz: 3.63dB	
1GHz~18GHz: 4.16dB	
Vertical: 30MHz~300MHz: 4.18dB	
300MHz~1GHz: 3.60dB	
1GHz~18GHz: 4.76dB	
Radiated Emission Measurement - AC2	
The maximum measurement uncertainty is evaluated as:	
Horizontal: 30MHz~300MHz: 3.75dB	
300MHz~1GHz: 3.53dB	
1GHz~18GHz: 4.28dB	
Vertical: 30MHz~300MHz: 3.86dB	
300MHz~1GHz: 3.53dB	
1GHz~18GHz: 4.33dB	

7. TEST RESULT

7.1. Summary

FCC Part Section(s)	RSS Section(s)	Test Description	Test Condition	Test Result	Reference
15.207	RSS-Gen Clause 8.8	AC Conducted Emissions 150kHz - 30MHz	Line Conducted	N/A	Section 7.2
15.205,15.231(e)	RSS-210, A1.4	Radiated Spurious Emissions	Radiated	Pass	Section 7.3
15.231(c)	RSS-210, A1.3	20dB & 99% Bandwidth		Pass	Section 7.4
15.231(e)	RSS-210, A1.4	Transmission Time		Pass	Section 7.5

Notes:

- 1) All modes of operation and data rates were investigated. The test results shown in the following sections represent the worst-case emissions.
- 2) The radiation measurements are performed in X, Y, Z axis positioning. Only the worst case is shown in the report.
- 3) "N/A" means that the test item is not applicable, and the detailed information refers to relevant section.

7.2. Conducted Emission

7.2.1. Test Limit

FCC Part 15.207 & RSS-Gen Limits		
Frequency (MHz)	QP (dBuV)	AV (dBuV)
0.15 ~ 0.50	66 ~ 56	56 ~ 46
0.50 ~ 5.0	56	46
5.0 ~ 30	60	50

Note 1: The lower limit shall apply at the transition frequencies.

Note 2: The limit decreases linearly with the logarithm of the frequency in the range 0.15MHz to 0.5MHz.

7.2.2. Test Setup

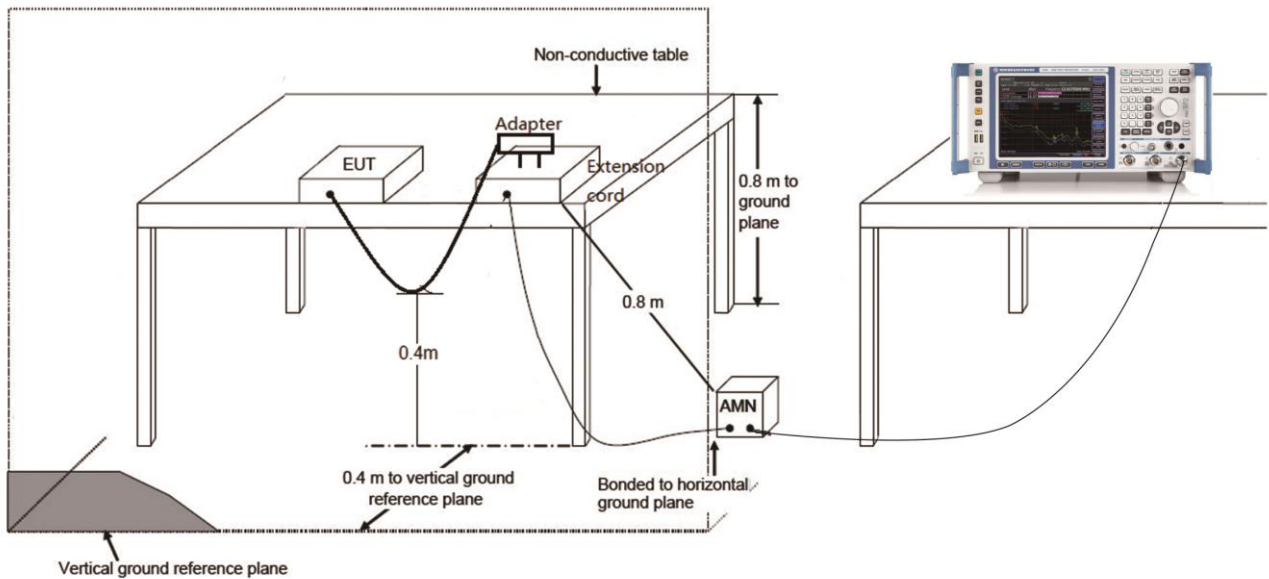

7.2.3. Test Result

The EUT is powered by battery, so this requirement does not apply.

7.3. Radiated Emissions

7.3.1. Standard Applicable

According to §15.231(e), the field strength of emissions from intentional radiators operated under this section shall not exceed the following:

Fundamental Frequency (MHz)	Field strength of fundamental (microvolts/meter)	Field strength of spurious emission (microvolts/meter)
40.66-40.77	1000	100
70-130	500	50
130-174	500 to 1500 ¹	50 to 150 ¹
174-260	1500	150
260-470	1500 to 5000 ¹	150 to 500 ¹
Above 470	5000	500

The limits on the field strength of the spurious emissions in the above table are based on the fundamental frequency of the intentional radiator. Spurious emissions shall be attenuated to the average (or, alternatively, CISPR quasi-peak) limits shown in this table or to the general limits shown in §15.209, whichever limit permits a higher field strength.

The emission limit in this paragraph is based on measurement instrumentation employing an average detector. The provisions in §15.35 for limiting peak emissions apply. Spurious Radiated Emissions measurements start below or at the lowest crystal frequency.

Compliance with the provisions of §15.205 shall be demonstrated using the measurement instrumentation specified in that section.

For 15.205 requirement:

Radiated emissions which fall in the restricted bands, as defined in Section 15.205(a) of FCC part 15, must also comply with the radiated emission limits specified in Section 15.209(a).

Frequency (MHz)	Frequency (MHz)	Frequency (MHz)	Frequency (GHz)
0.090 - 0.110	16.42 - 16.423	399.9 - 410	4.5 - 5.15
¹ 0.495 - 0.505	16.69475 - 16.69525	608 - 614	5.35 - 5.46
2.1735 - 2.1905	16.80425 - 16.80475	960 - 1240	7.25 - 7.75
4.125 - 4.128	25.5 - 25.67	1300 - 1427	8.025 - 8.5
4.17725 - 4.17775	37.5 - 38.25	1435 - 1626.5	9.0 - 9.2
4.20725 - 4.20775	73 - 74.6	1645.5 - 1646.5	9.3 - 9.5
6.215 - 6.218	74.8 - 75.2	1660 - 1710	10.6 - 12.7
6.26775 - 6.26825	108 - 121.94	1718.8 - 1722.2	13.25 - 13.4
6.31175 - 6.31225	123 - 138	2200 - 2300	14.47 - 14.5
8.291 - 8.294	149.9 - 150.05	2310 - 2390	15.35 - 16.2
8.362 - 8.366	156.52475 - 156.525	2483.5 - 2500	17.7 - 21.4
8.37625 - 8.38675	156.7 - 156.9	2690 - 2900	22.01 - 23.12
8.41425 - 8.41475	162.0125 - 167.17	3260 - 3267	23.6 - 24.0
12.29 - 12.293	167.72 - 173.2	3332 - 3339	31.2 - 31.8
12.51975 - 12.52025	240 - 285	3345.8 - 3358	36.43 - 36.5
12.57675 - 12.57725	322 - 335.4	3600 - 4400	(²)
13.36 - 13.41	--	--	--

For RSS-Gen Section 8.10 Requirement:

Radiated emissions which fall in the restricted bands, as defined in Section 8.10 of RSS-Gen, must also comply with the radiated emission limits specified in Section 8.9.

Frequency (MHz)	Frequency (MHz)	Frequency (MHz)	Frequency (GHz)
0.090 - 0.110	16.42 - 16.423	1645.5 - 1646.5	9.0 - 9.2
0.495 - 0.505	16.69475 - 16.69525	1660 - 1710	9.3 - 9.5
2.1735 - 2.1905	16.80425 - 16.80475	1718.8-1722.2	10.6 - 12.7
3.020 - 3.026	25.5 - 25.67	2200 - 2300	13.25 - 13.4
4.125 - 4.128	37.5 - 38.25	2310-2390	14.47 - 14.5
4.17725 - 4.17775	73 - 74.6	2483.5 - 2500	15.35 - 16.2
4.20725 - 4.20775	74.8 - 75.2	2655 - 2900	17.7 - 21.4
5.677 - 5.683	108 - 138	3260 - 3267	22.01 - 23.12
6.215 - 6.218	149.9 - 150.05	3332 - 3339	23.6 - 24.0
6.26775 - 6.26825	156.52475 - 156.52525	3345.8 - 3358	31.2 - 31.8
6.31175 - 6.31225	156.7 - 156.9	3500 - 4400	36.43 - 36.5
8.291 - 8.294	162.0125 - 167.17	4500 - 5150	Above 38.6
8.362 - 8.366	167.72 - 173.2	5350 - 5460	--
8.37625 - 8.38675	240 - 285	7250 - 7750	--
8.41425 - 8.41475	322 - 335.4	8025 - 8500	--
12.29 - 12.293	399.9 - 410	--	--
12.51975 - 12.52025	608 - 614	--	--
12.57675 - 12.57725	960 - 1427	--	--
13.36 -13.41	1435 - 1626.5	--	--

7.3.2. Test Setup

Below 1GHz Test Setup:

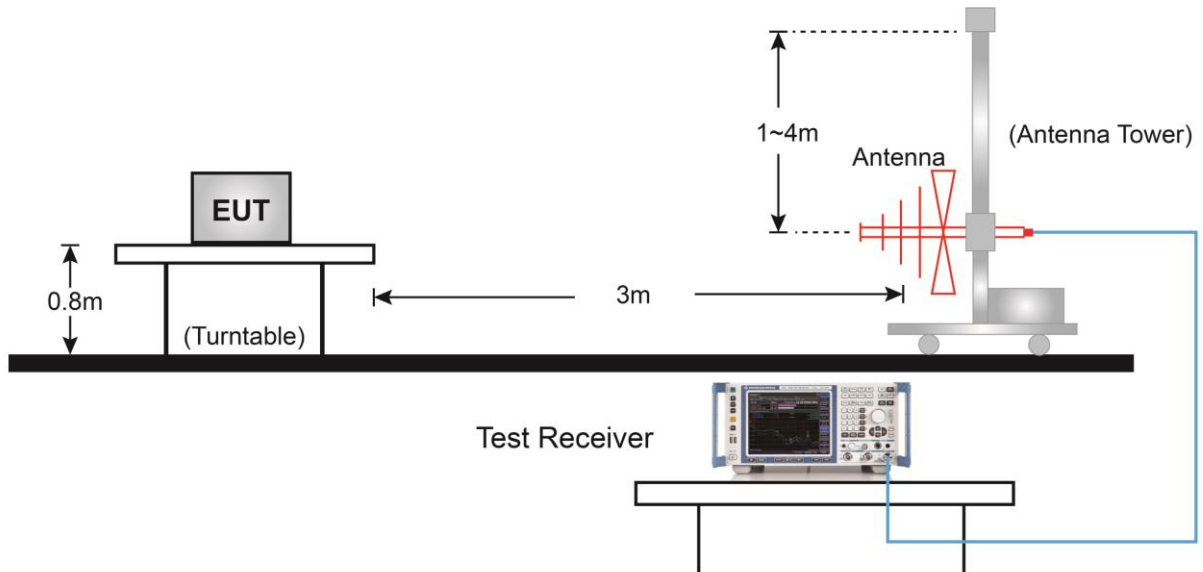

Above 1GHz Test Setup:

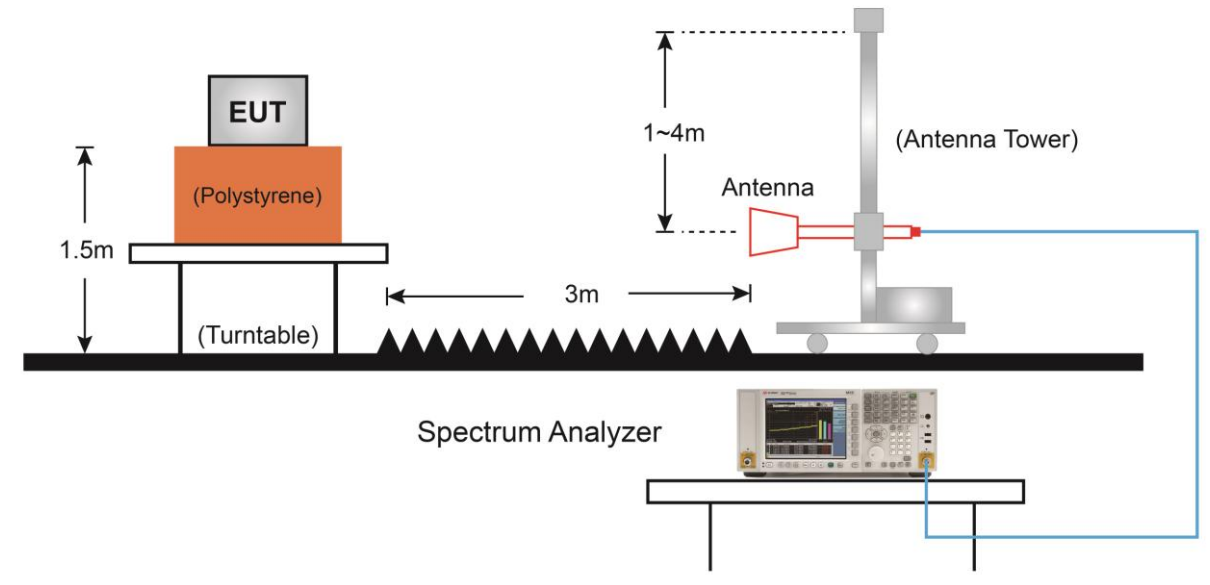

7.3.3. Test Results

Product	Tire Pressure Monitoring System Sensor	Temperature	24°C
Test Engineer	Dandy Li	Relative Humidity	59%
Test Site	AC2	Test Date	2019/08/09
Remark	Fundamental Radiated Emission		

Frequency (MHz)	Modulation Type	Reading Level (dBμV)	Factor (dB)	Measure Level (dBμV/m)	Limit (dBμV/m)	Margin (dB)	Detector	Polarization
433.92	ASK	55.3	16.9	72.2	72.9	-0.7	PK	Horizontal
		53.2	16.9	70.1	72.9	-2.8	PK	Vertical
	FSK	55.3	16.9	72.2	72.9	-0.7	PK	Horizontal
		53.6	16.9	70.5	72.9	-2.4	PK	Vertical
315	ASK	49.4	14.7	64.1	67.7	-3.6	PK	Horizontal
		45.0	14.7	59.7	67.7	-8.0	PK	Vertical
	FSK	52.6	14.7	67.3	67.7	-0.4	PK	Horizontal
		45.5	14.7	60.2	67.7	-7.5	PK	Vertical

Note: Measure Level (dBμV/m) = Reading Level (dBμV) + Factor (dB)

Factor (dB) = Cable Loss (dB) + Antenna Factor (dB/m)

Product	Tire Pressure Monitoring System Sensor	Temperature	24°C
Test Engineer	Dandy Li	Relative Humidity	59%
Test Site	AC2	Test Date	2019/08/13
Remark:	Radiated Spurious Emissions - 433.92MHz		

Frequency (MHz)	Reading Level (dBμV)	Factor (dB)	Measure Level (dBμV/m)	Limit (dBμV/m)	Margin (dB)	Detector	Polarization
ASK Modulation							
867.6	7.0	23.3	30.3	46.0	-15.7	PK	Horizontal
1735.0	42.7	-4.7	38.0	74.0	-36.0	PK	Horizontal
2170.0	43.0	-1.6	41.4	74.0	-32.6	PK	Horizontal
2602.5	41.9	-1.9	40.0	74.0	-34.0	PK	Horizontal
3037.5	46.0	-2.0	44.0	74.0	-30.0	PK	Horizontal
775.3	3.7	22.1	25.8	46.0	-20.2	PK	Vertical
1377.5	40.9	-4.2	36.7	74.0	-37.3	PK	Vertical
1545.0	41.5	-4.8	36.7	74.0	-37.3	PK	Vertical
1990.0	40.5	-3.6	36.9	74.0	-37.1	PK	Vertical
2597.5	39.5	-1.9	37.6	74.0	-36.4	PK	Vertical
FSK Modulation							
45.1	2.9	14.7	17.6	40.0	-22.4	PK	Horizontal
2170.0	41.9	-1.6	40.3	74.0	-33.7	PK	Horizontal
2605.0	41.5	-1.9	39.6	74.0	-34.4	PK	Horizontal
3037.5	43.5	-2.0	41.5	74.0	-32.5	PK	Horizontal
3472.5	43.0	-0.9	42.1	74.0	-31.9	PK	Horizontal
44.5	3.4	14.6	18.0	40.0	-22.0	PK	Vertical
1375.0	40.8	-4.2	36.6	74.0	-37.4	PK	Vertical
1555.0	40.5	-4.8	35.7	74.0	-38.3	PK	Vertical
1992.5	39.1	-3.5	35.6	74.0	-38.4	PK	Vertical
2987.5	40.4	-2.1	38.3	74.0	-35.7	PK	Vertical

Note 1: Peak Measure Level (dBμV/m) = Reading Level (dBμV) + Factor (dB)

Factor (dB) = Cable Loss (dB) + Antenna Factor (dB/m) – Pre Amplifier Gain (dB)

Note 2: Average measurement was not performed when the peak level lower than average limit.

Note 3: The test trace is same as the ambient noise (the test frequency range: 9 kHz ~ 30 MHz and 18 GHz ~ 25 GHz), therefore no data appear in the report.

Product	Tire Pressure Monitoring System Sensor	Temperature	24°C
Test Engineer	Dandy Li	Relative Humidity	59%
Test Site	AC2	Test Date	2019/08/15
Remark:	Radiated Spurious Emissions - 315MHz		

Frequency (MHz)	Reading Level (dBμV)	Factor (dB)	Measure Level (dBμV/m)	Limit (dBμV/m)	Margin (dB)	Detector	Polarization
ASK Modulation							
945.2	7.7	23.9	31.6	46.0	-14.4	PK	Horizontal
1575.0	43.6	-4.7	38.9	74.0	-35.1	PK	Horizontal
1890.0	41.9	-4.1	37.8	74.0	-36.2	PK	Horizontal
3150.0	44.7	-1.6	43.1	74.0	-30.9	PK	Horizontal
4877.5	38.5	3.6	42.1	74.0	-31.9	PK	Horizontal
629.3	6.9	20.0	26.9	46.0	-19.1	PK	Vertical
1385.0	41.5	-4.2	37.3	74.0	-36.7	PK	Vertical
1555.0	40.7	-4.8	35.9	74.0	-38.1	PK	Vertical
3142.5	39.9	-1.6	38.3	74.0	-35.7	PK	Vertical
4595.0	37.4	3.0	40.4	74.0	-33.6	PK	Vertical
FSK Modulation							
569.6	2.5	19.2	21.7	46.0	-24.3	PK	Horizontal
1575.0	47.8	-4.7	43.1	74.0	-30.9	PK	Horizontal
2052.5	40.0	-2.9	37.1	74.0	-36.9	PK	Horizontal
2520.0	40.1	-2.2	37.9	74.0	-36.1	PK	Horizontal
3990.0	39.2	0.3	39.5	74.0	-34.5	PK	Horizontal
629.6	8.7	20.0	28.7	46.0	-17.3	PK	Vertical
1345.0	40.1	-3.8	36.3	74.0	-37.7	PK	Vertical
1542.5	41.3	-4.8	36.5	74.0	-37.5	PK	Vertical
1987.5	40.1	-3.6	36.5	74.0	-37.5	PK	Vertical
4000.0	39.7	0.4	40.1	74.0	-33.9	PK	Vertical

Note 1: Peak Measure Level (dBμV/m) = Reading Level (dBμV) + Factor (dB)

Factor (dB) = Cable Loss (dB) + Antenna Factor (dB/m) – Pre Amplifier Gain (dB)

Note 2: Average measurement was not performed when the peak level lower than average limit.

Note 3: The test trace is same as the ambient noise (the test frequency range: 9 kHz ~ 30 MHz and 18 GHz ~ 25 GHz), therefore no data appear in the report.

7.4. 20dB & 99% Bandwidth

7.4.1. Standard Applicable

According to FCC Part 15.231(c), the bandwidth of the emission shall be no wider than 0.25% of the center frequency for devices operating above 70MHz and below 900MHz. Bandwidth is determined at the points 20 dB down from the modulated carrier.

7.4.2. Test Procedure

With the EUT's antenna attached, the EUT's 20dB Bandwidth power was received by the test antenna, which was connected to the spectrum analyzer with the START, and STOP frequencies set to the EUT's operation band.

7.4.3. Test Setup

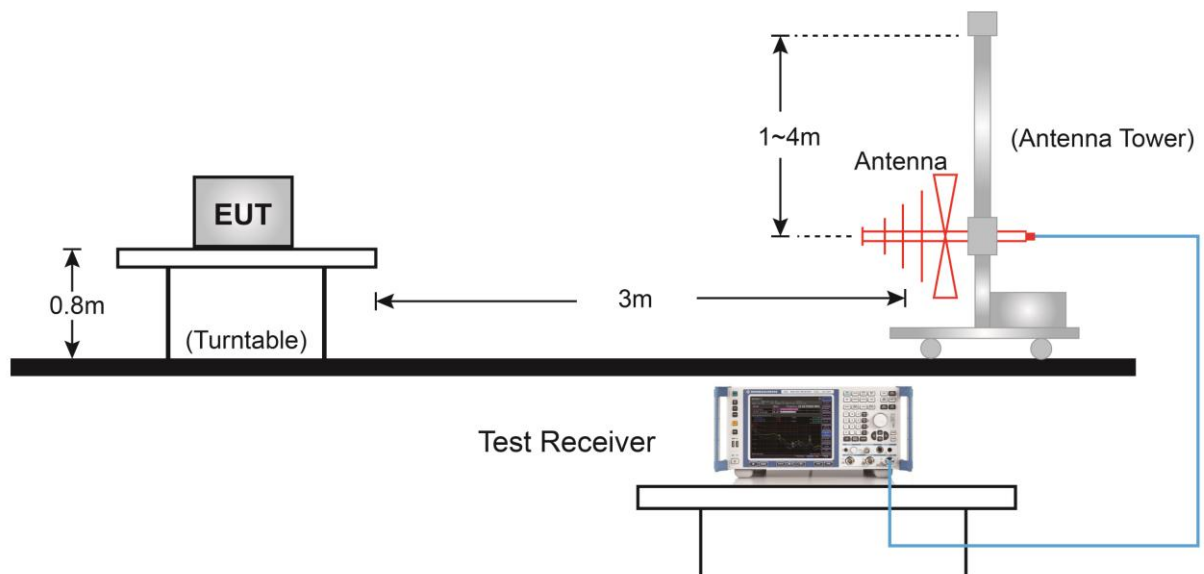

7.4.4. Test Result

Product	Tire Pressure Monitoring System Sensor	Temperature	25°C
Test Engineer	Vincent Yu	Relative Humidity	52%
Test Site	AC1	Test Date	2019/08/07

Frequency (MHz)	Modulation Type	20dB Bandwidth (KHz)	99% Bandwidth (KHz)	Limit (KHz)	Result
433.92	ASK	79.86	175.48	≤ 1084.8	Pass
	FSK	100.50	117.90	≤ 1084.8	Pass
315	ASK	69.70	150.43	≤ 787.5	Pass
	FSK	123.70	110.88	≤ 787.5	Pass

Note:

1. For 433.92MHz: Limit = Fundamental Frequency * 0.25% = 433.92 MHz * 0.25% = 1084.8 kHz
2. For 315MHz: Limit = Fundamental Frequency * 0.25% = 315 MHz * 0.25% = 787.5 kHz

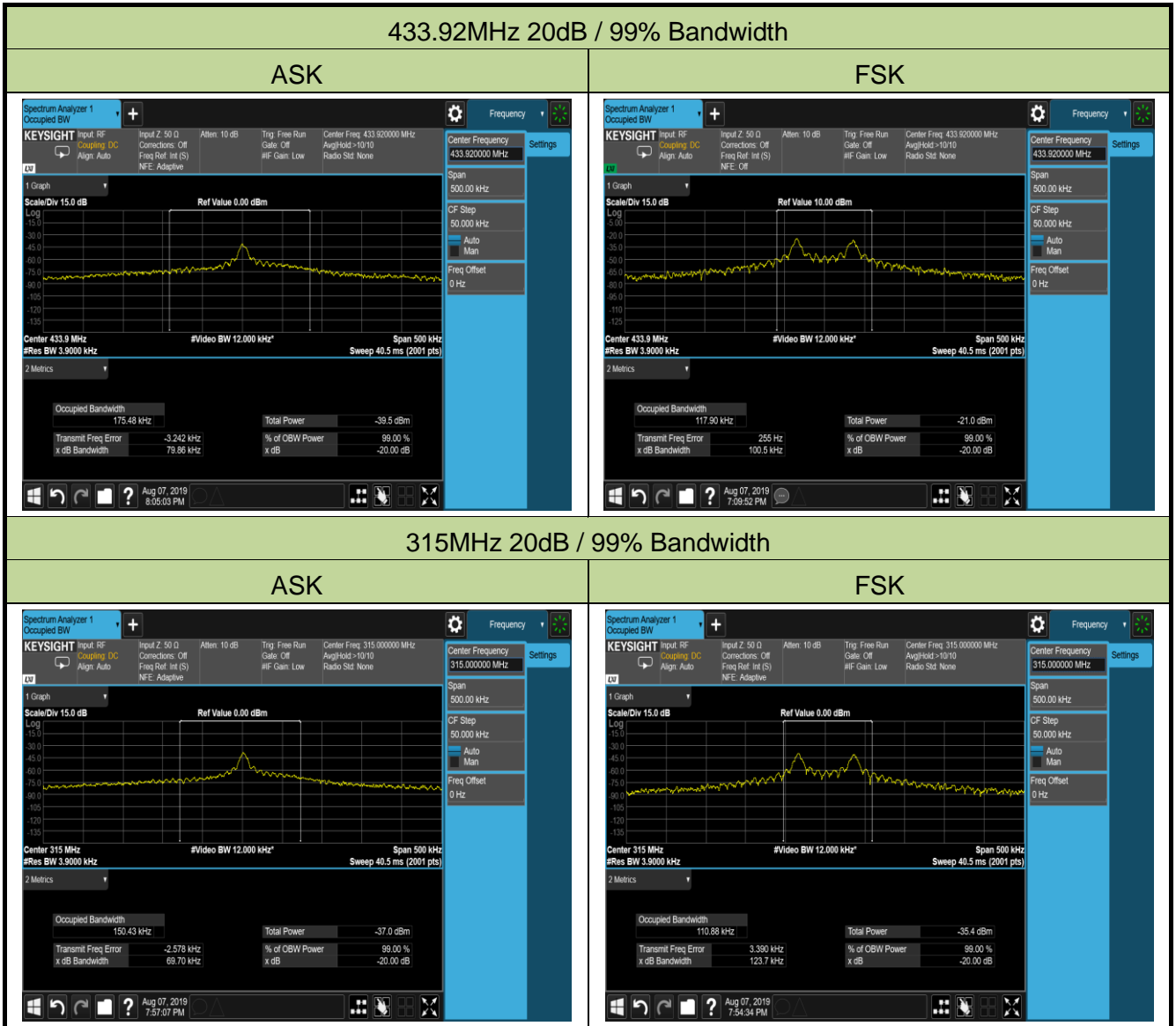

7.5. Transmission Time

7.5.1. Standard Applicable

According to FCC 15.231(e), devices operated under the provisions of this paragraph shall be provided with a means for automatically limiting operation so that the duration of each transmission shall not be greater than one second and the silent period between transmissions shall be at least 30 times the duration of the transmission but in no case less than 10 seconds.

7.5.2. Test Procedure

With the EUT's antenna attached, the EUT's output signal was received by the test antenna, which was connected to the spectrum analyzer. Set the center frequency to 433.92MHz, then set the spectrum analyzer to Zero Span for the release time reading. During the testing, the switch was released then the EUT automatically deactivated.

7.5.3. Test Setup

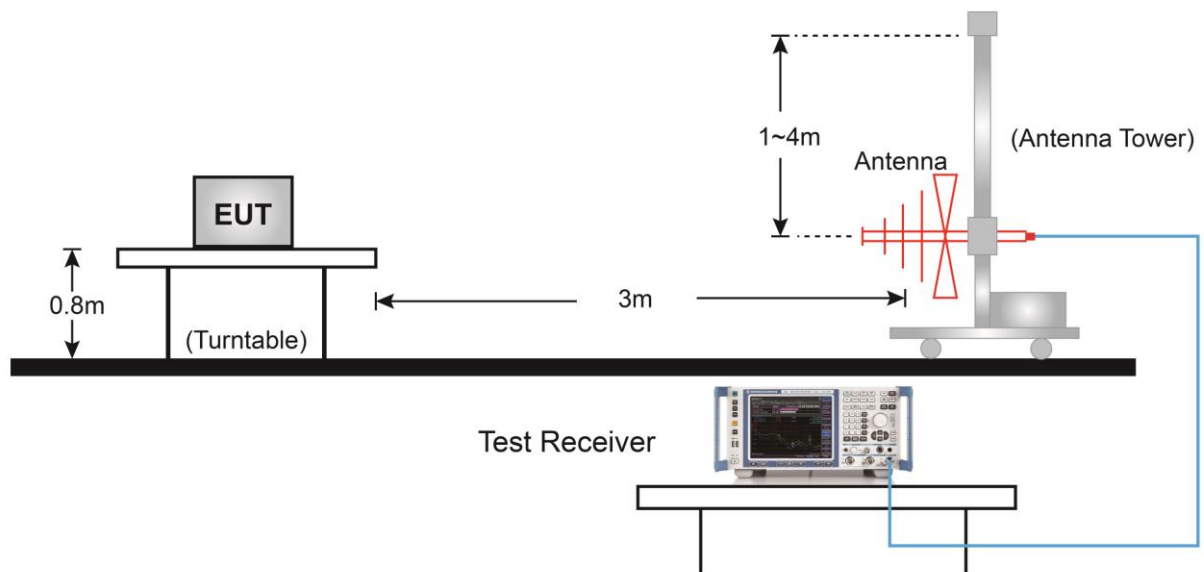

7.5.4. Test Result

Product	Tire Pressure Monitoring System Sensor	Temperature	25°C
Test Engineer	Vincent Yu	Relative Humidity	52%
Test Site	AC1	Test Date	2019/08/07

Frequency	Modulation Type	Item	Measured Value	Limit	Result
433.92MHz	ASK	Transmission Time (T_{on})	112 ms	≤ 1 s	Pass
		Silent Time	12.3 s	≥ 10 s	Pass
		Silent Time/Transmission Time	110 times	≥ 30 times	Pass
	FSK	Transmission Time (T_{on})	42 ms	≤ 1 s	Pass
		Silent Time	12.18 s	≥ 10 s	Pass
		Silent Time/Transmission Time	290 times	≥ 30 times	Pass
315MHz	ASK	Transmission Time (T_{on})	112 ms	≤ 1 s	Pass
		Silent Time	12.19 s	≥ 10 s	Pass
		Silent Time/Transmission Time	109 times	≥ 30 times	Pass
	FSK	Transmission Time (T_{on})	42 ms	≤ 1 s	Pass
		Silent Time	12.21 s	≥ 10 s	Pass
		Silent Time/Transmission Time	291 times	≥ 30 times	Pass

Note:

- For 422.92MHz ASK Modulation: Transmission Time (T_{on}) = (28×4) ms = 112 ms
 For 422.92MHz FSK Modulation: Transmission Time (T_{on}) = (14×3) ms = 42 ms
- For 315MHz ASK Modulation: Transmission Time (T_{on}) = (28×4) ms = 112 ms
 For 315MHz FSK Modulation: Transmission Time (T_{on}) = (14×3) ms = 42 ms

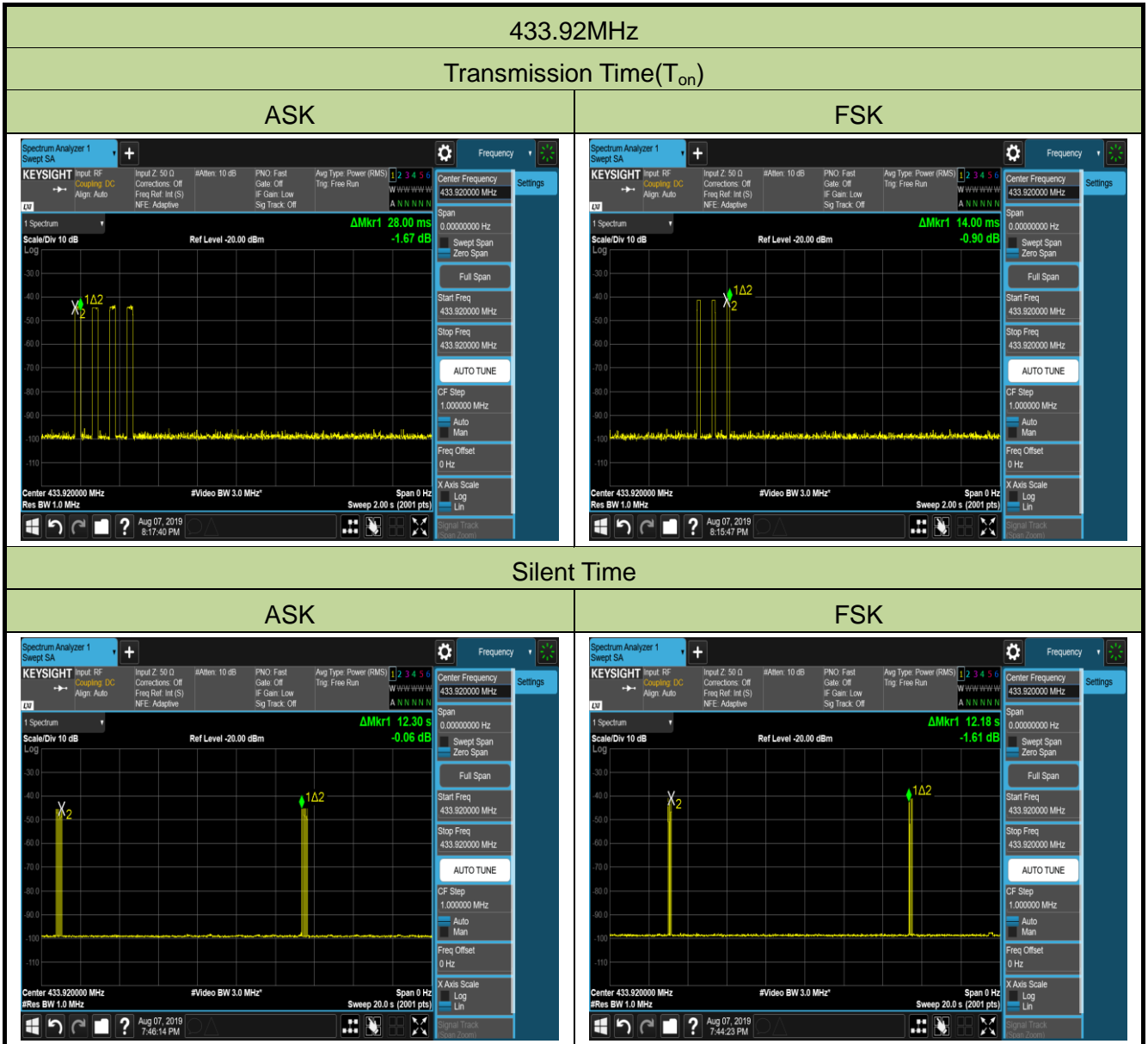

315MHz

Transmission Time(T_{on})

ASK

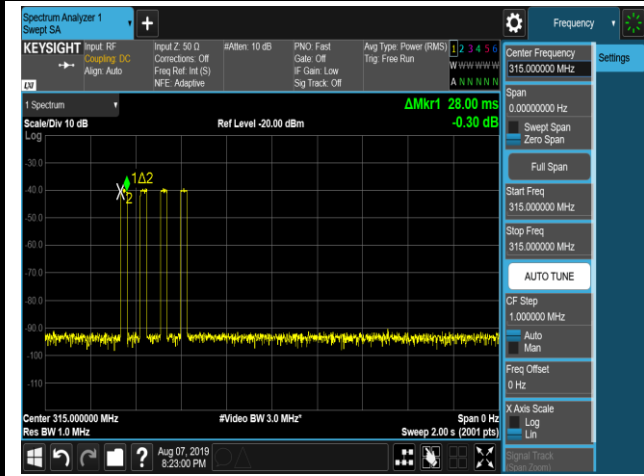

FSK

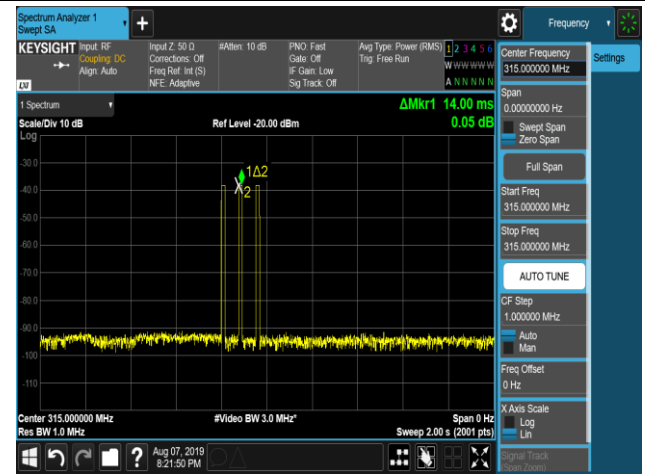

Silent Time

ASK



FSK



8. CONCLUSION

The data collected relate only the item(s) tested and show that the unit is compliance with FCC and ISED Rules.

The End

Appendix A - Test Setup Photograph

Refer to "1907RSU046-UT" file.

Appendix B - EUT Photograph

Refer to "1907RSU046-UE" file.