

TSB38 User manual

FCC ID: TTETSB38

1. General Description

Tire pressure sensor is composed of RF chip, battery, antenna and Rf matching network. It is applied to monitor tire pressure, temperature and acceleration and the tire data is transmitted via center frequency 433.92MHz.

2. Operation Functions

Transmitter ID Programming: transmitter ID can be programmed for easy replacement

Alarm Record Inquiry: automatically record the 10 alarm records

Standard Pressure Programming: standard pressure for each tire can be programmed on monitor

3. Product Features

Powerful functions including low pressure alarms in 3 levels, fast leak alarm and standard pressure setting etc.

Monitor connects to continuous power to ensure full-time monitoring

Design of the whole system matches the truck perfectly

Simple operation for function programming and inquiry

4. Installing structure

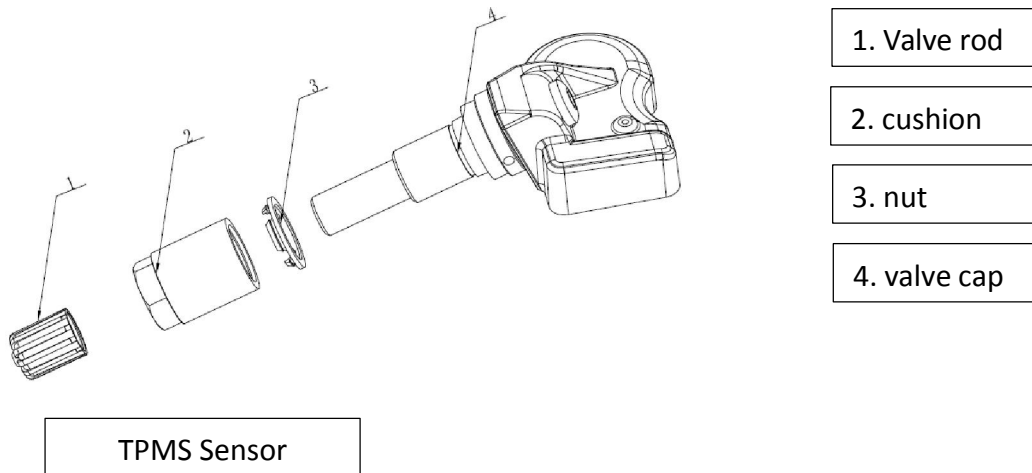

5. Installation requirements

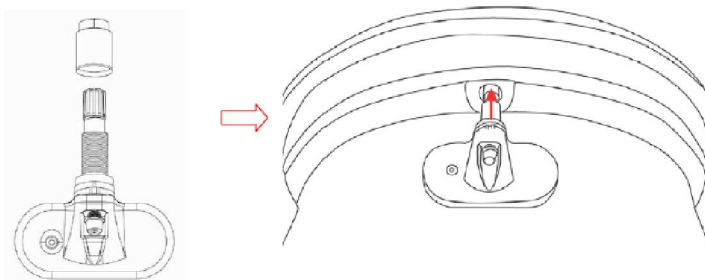

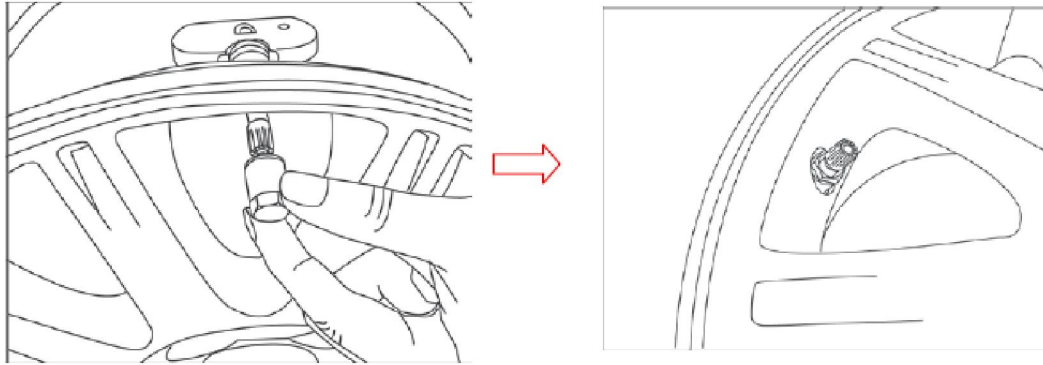

moment:3.8N.m($\pm 0.3N$)



Tires must do dynamic balance testing and adjusting.

Federal Communications Commission (FCC) Interference Statement

This equipment has been tested and found to comply with the limits for a Class B digital device, pursuant to Part 15 of the FCC Rules.

These limits are designed to provide reasonable protection against harmful interference in a residential installation. This equipment generate, uses and can radiate radio frequency energy and, if not installed and used in accordance with the instructions, may cause harmful interference to radio communications.

However, there is no guarantee that interference will not occur in a particular installation. If this equipment does cause harmful interference to radio or television reception, which can be determined by turning the equipment off and on, the user is encouraged to try to correct the interference by one of the following measures:

- Reorient or relocate the receiving antenna.
- Increase the separation between the equipment and receiver.
- Connect the equipment into an outlet on a circuit different from that to which the receiver is connected.
- Consult the dealer or an experienced radio/TV technician for help.

This device complies with Part 15 of the FCC Rules. Operation is subject to the following two conditions:

- (1) This device may not cause harmful interference, and
- (2) this device must accept any interference received, including interference that may cause undesired operation.

FCC Caution: Any changes or modifications not expressly approved by the party responsible for compliance could void the user's authority to operate this equipment.

RF exposure warning

This equipment complies with FCC radiation exposure limits set forth for an uncontrolled environment.

This equipment must not be collocated or operating in conjunction with any other antenna or transmitter.