

Marking Drawing

Rev. Date: 2006-09-12	Rev. 3.0	Document No. 108047
Prepared by: Harald Rygge	Subj. Resp.: Agnar Kopperud	Approved by: Ole-Christian Sørli
Nera WorldPro 1010 - Interface Unit Label for s/n printing		

Document Size = A4

Scale : See scaling indicator

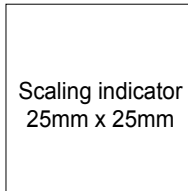

Printinting colours (as shown in figure):

- Black = Pantone Process Black
- Light grey = Pantone Cool Grey 4 C
- Dark grey = Pantone Cool Grey 11 C

Label base colour = White

Fonts used = The Sans (outlines created - font independent)

Observe !

The actual barcodes are to be printed during assembly process of antenna unit itself.
No preprinting of barcodes / subnumbers. The bar code symbology is Code 128-B.

Text and Bar code field information:

- Article code = 108034
- r.r = Revision from PDM system
- n... = IMEI number
- ww = Manufacturer ID
- yymm = Actual year and month
- xxxx = Consecutive (serial no.) numbers incremented from 0001, starting at 0001 each new month.
- a... = Physical address (text only - no bars)

Observe !

The complete serial number should be printed in a continuous sequence without notes of conjunction, or spaces. (wwyymmxxxx)

Preprinted label layout / graphic:

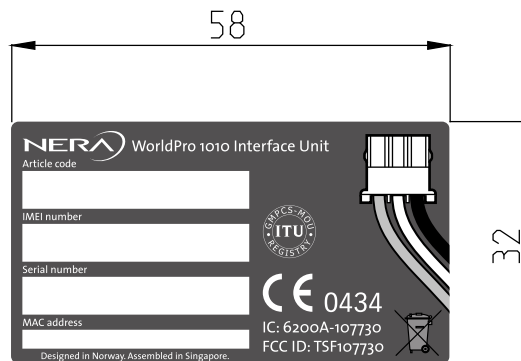

Example showing label after printing of bar codes:

