





	1	2	3	4	5	6	7	8
D								
C								
B								
A								
	1	2	3	4	5	6	7	8

XCRF-860-RD  
 XCRF-860-RD-SHEET1.Sch  

XCRF-860-RD  
 XCRF-860-RD-Sheet2.Sch  

XCRF-860-RD  
 XCRF-860-RD-SHEET3.SCH  

XCRF-860-RD  
 XCRF-860-RD-SHEET4.Sch  

				designer	CaoChun	XCRF-860 Reader	YW5.948.165DL	
				auditor	WenYiQing		A3	V1.3
				standardization	LiuLiHua	Page 1	Total 5	
				authorize	WenYiQing	XCRF-860-RD_PCB-V1.5		
						INVENGO 2007.10.26		
						File: XCRF-860.SCH		

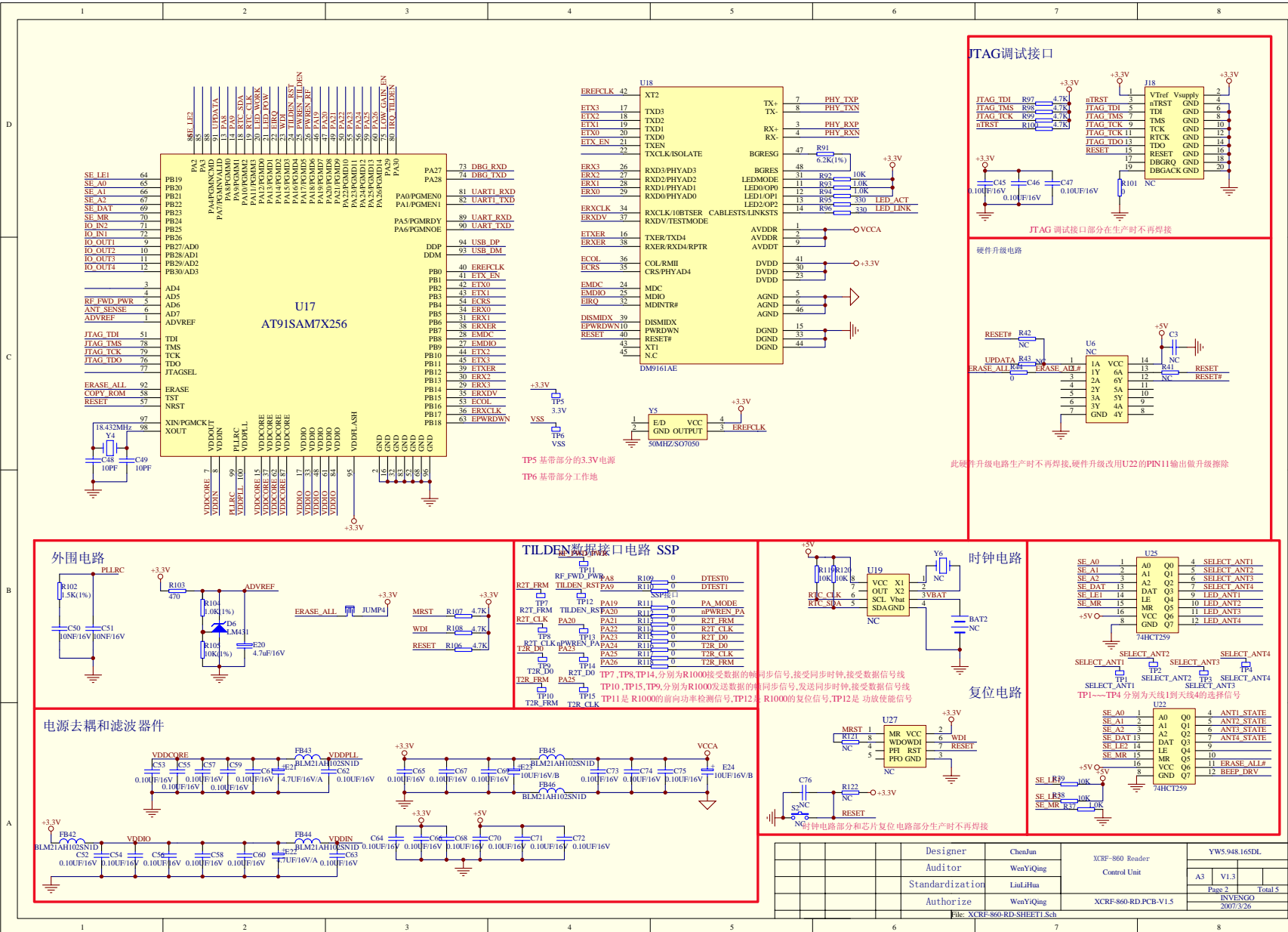

**U17 AT91SAM7X256**

SE_LE1	64	PB19	65	SE_A0	66	SE_A1	67	SE_A2	68	SE_DAT	69	SE_MR	70	IO_IN2	71	IO_IN1	72	IO_OUT1	73	IO_OUT2	74	IO_OUT3	75	IO_OUT4	76	IO_OUT5	77																																		
ERASE_ALL	92	ERASE_COPY_ROM	93	TST	94	NRST	95	XIN/PGMCK	96	XOUT	97	18.432MHz	Y4	10PF	C48	10PF	C49	10PF																																											
PA0	0	PA1	1	PA2	2	PA3	3	PA4	4	PA5	5	PA6	6	PA7	7	PA8	8	PA9	9	PA10	10	PA11	11	PA12	12	PA13	13	PA14	14	PA15	15	PA16	16	PA17	17	PA18	18	PA19	19	PA20	20	PA21	21	PA22	22	PA23	23	PA24	24	PA25	25	PA26	26	PA27	27	PA28	28	PA29	29	PA30	30

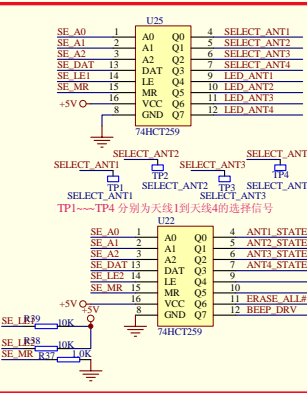
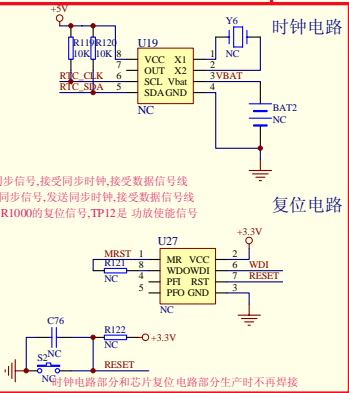
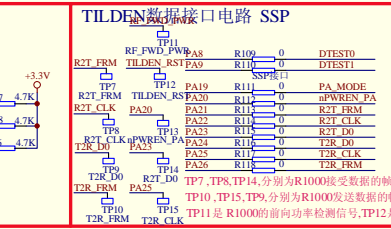
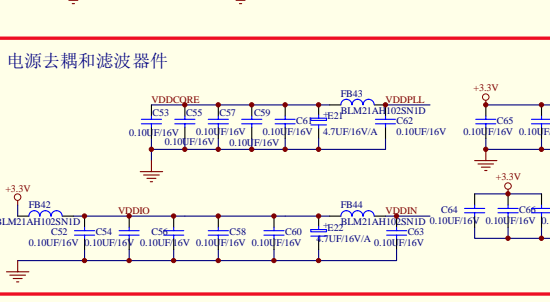
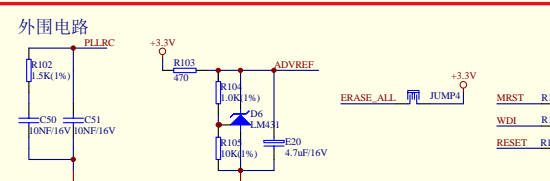
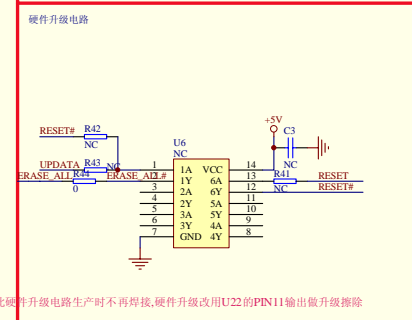
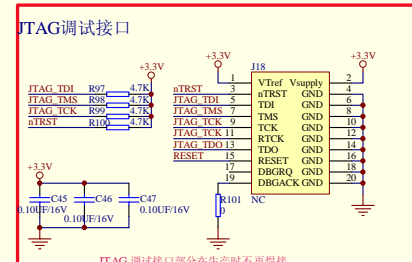
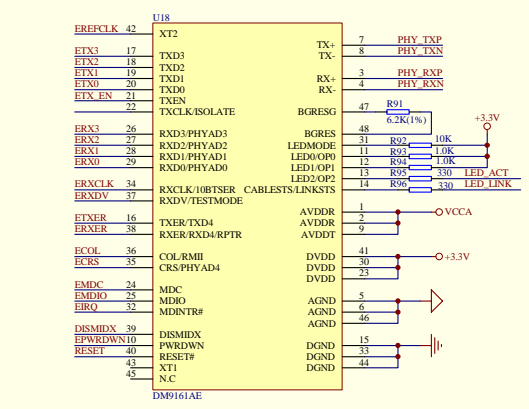

Designer	ChenJun	XCRF-860 Reader	YW5.948.165DL
Auditor	WenYiQing	Control Unit	A3
Standardization	LiutHua		V1.3
Authorize	WenYiQing	XCRF-860-RD-PCB-V1.5	Page 2
		File: XCRF-860-RD-SHEET1.Sch	Total 5
			Page 3
			INVENGO
			2007/3/26

### 接口插座

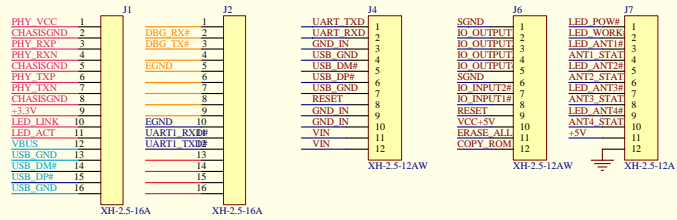

CHASISGND为以太网地 EGDND为串口地  
USB\_GND为USB地

### 人机接口部分电路

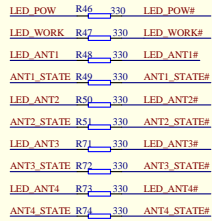

### 以太网网络接口

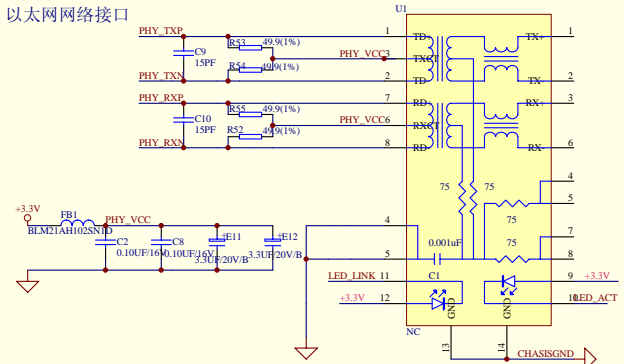

### 扩展外部IO接口

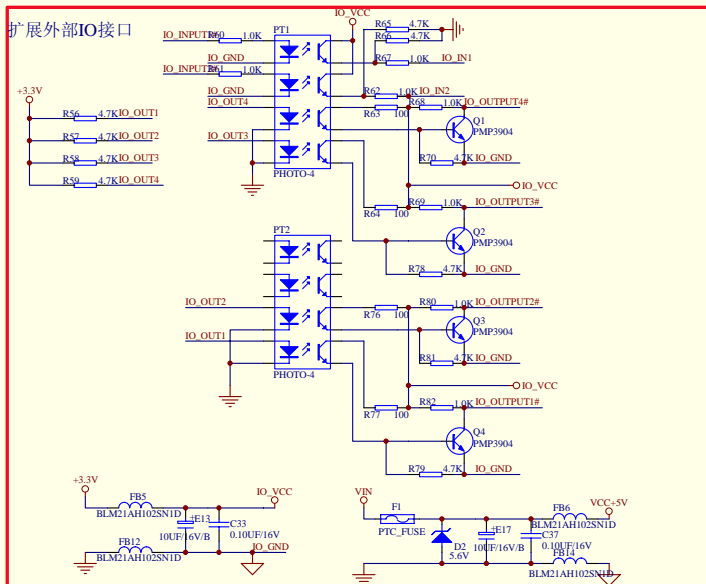

### 串行接口

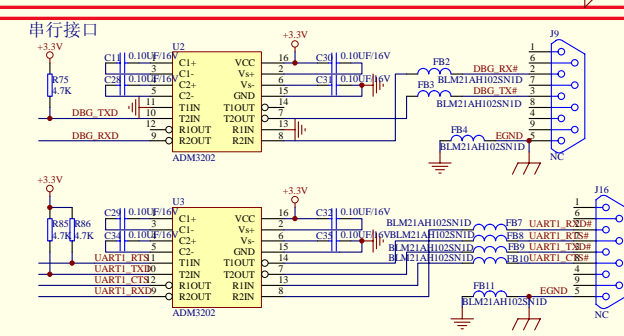

### USB接口

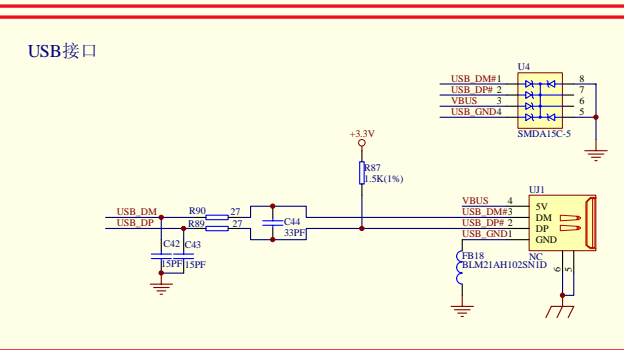

### 电源部分

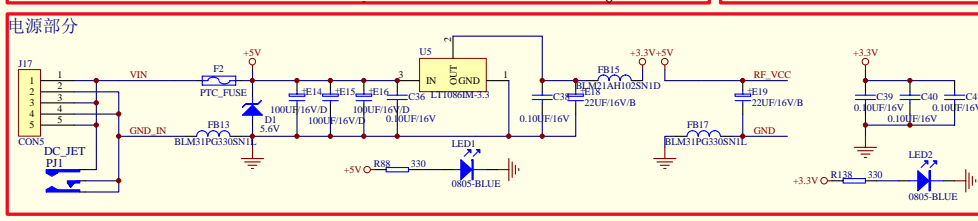

Designer	ChenJun	XCRF-860 Reader Interface	YW5.948.165DL	
Auditor	WenYiQing		A3	V1.3
Standardization	LiuLiHua	Page 3	Total 5	
Authorize	WenYiQing	XCRF-860-RD_PCB-V1.5		
File: XCRF-860-RD-SHEET2.Sch		INVENGO 2007.3.26		

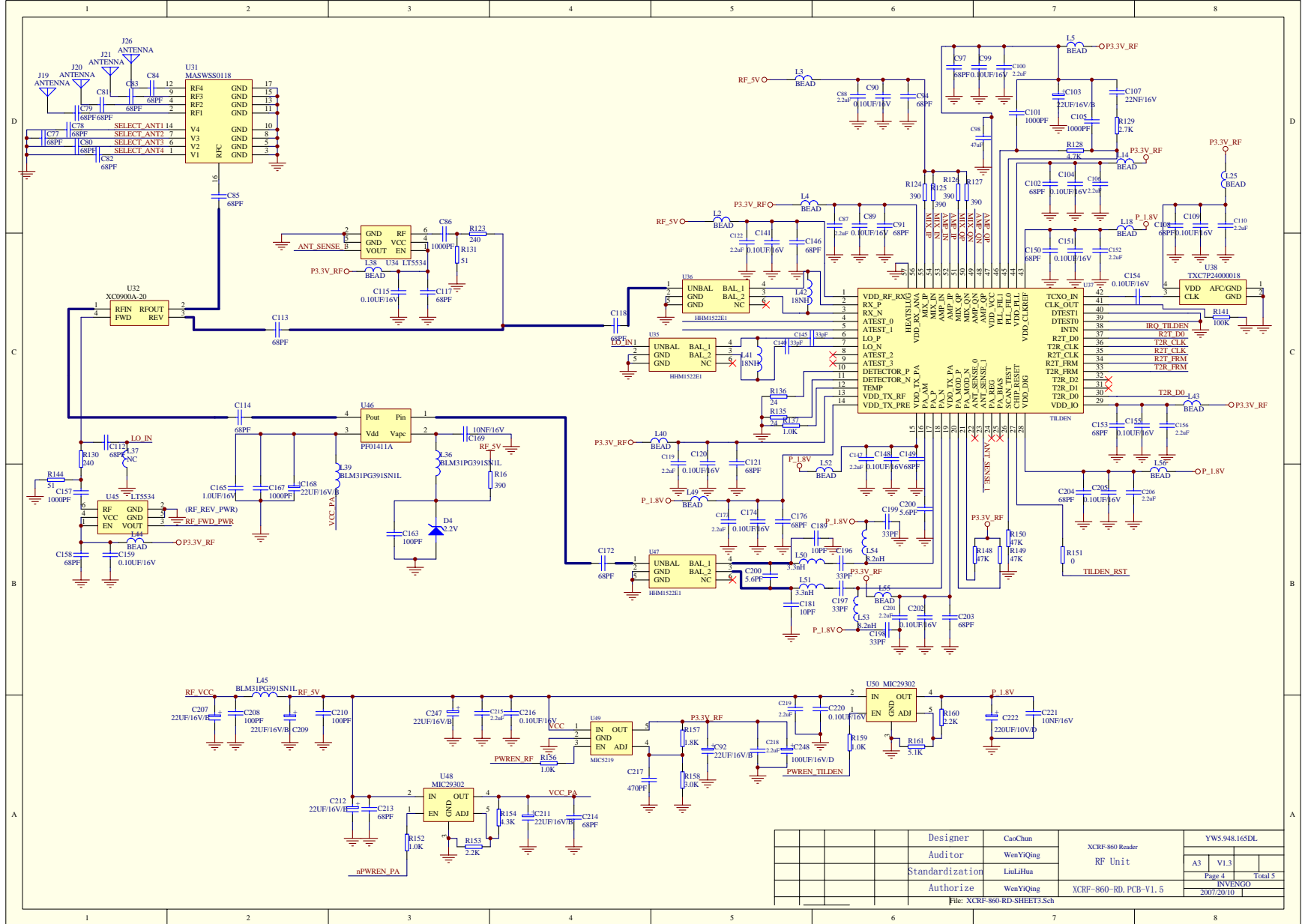

Designer	CaoChun	XCRF-860 Reader RF Unit	YWS-948.165DL	
Auditor	WenYiQing		A3	V1.3
Standardization	LiuLHua	Page 4		Total 5
Authorize	WenYiQing	INVENGO		2007/2010
File: XCRF-860-RD-SHEET3.Sch				

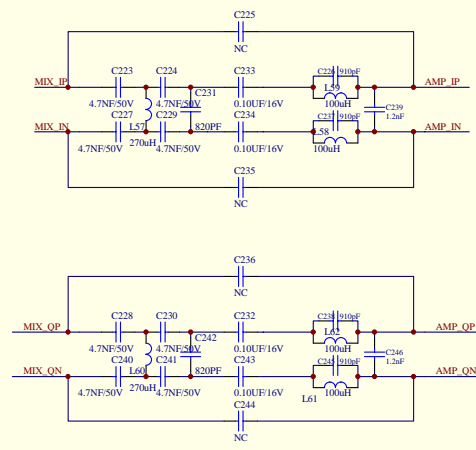

		Designer	CaoChan	XCRF-860 Reader	YW5.948.165DL	
		Auditor	WenYiQing	Densene Filter Unit	A3	V1.3
		Standardization	LiuJiHua		Page 5 Total 5	
		Authorize	WenYiQing	XCRF-860-RD.PCB-V1.5	INVENGO 2007.10.26	
File: XCRF-860-RD-SHEET4.Sch						

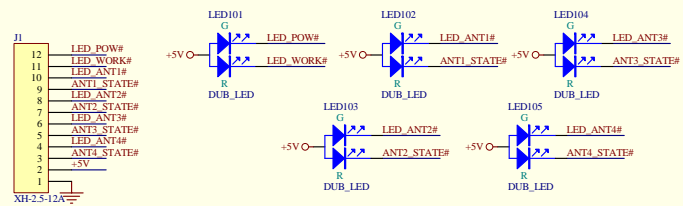

	Designer	ChenJun	XCRF-860 Reader		YW5 948.167DL
	Auditor	WenYiQing	LED Unit		
	Standardization	LiuLiHua	A3	V1.1	Total
	Authorize	WenYiQing	XCRF-860-LED.PCB-V1.0		INVENGO 2008/05/21

File: XCRF-860-LED\_Sch

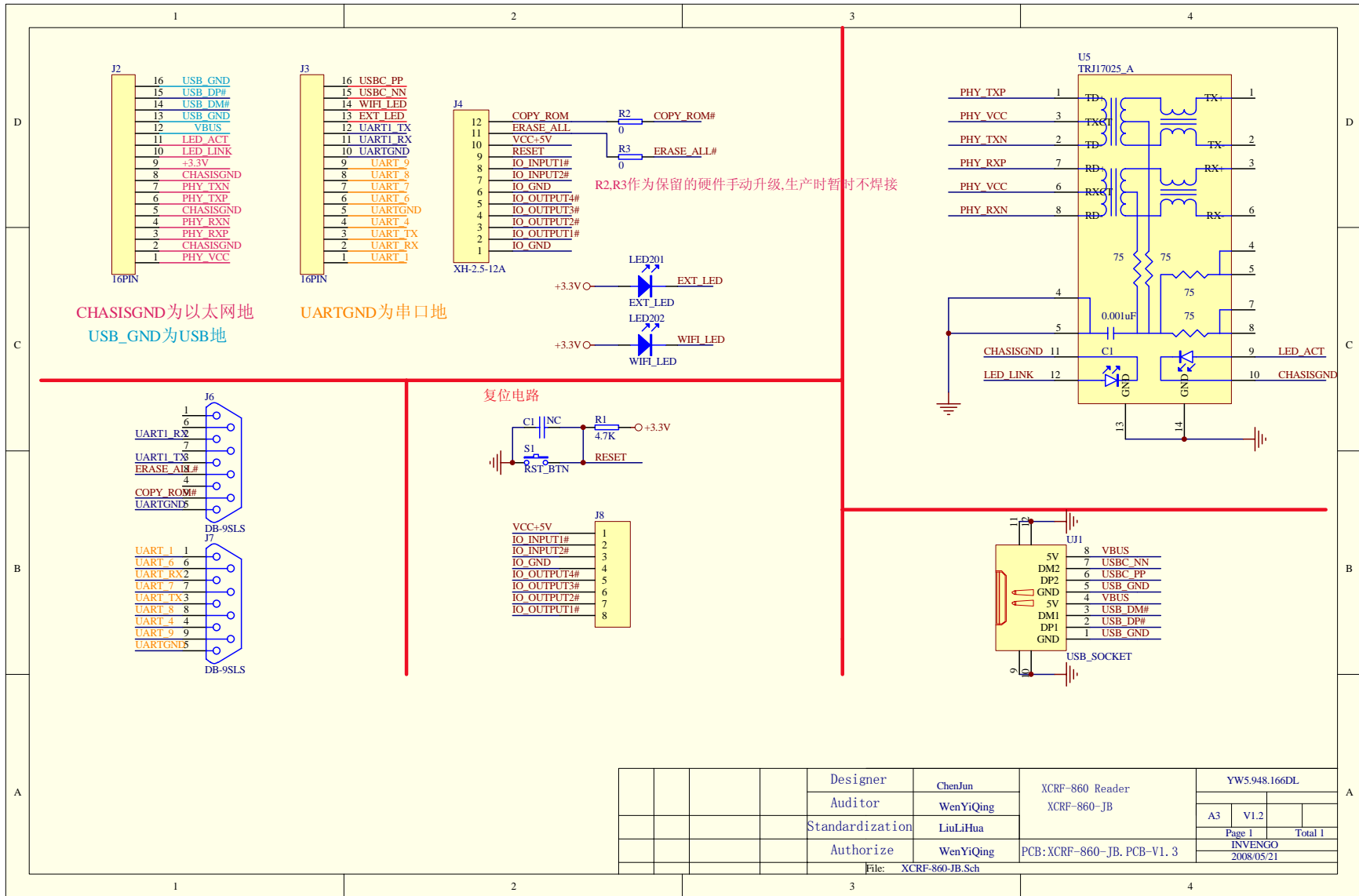

Designer	ChenJun	XCRF-860 Reader XCRF-860-JB	YW5.948.166DL	
Auditor	WenYiQing		A3	V1.2
Standardization	LiuLiHua	Page 1 Total 1		
Authorize	WenYiQing	PCB:XCRF-860-JB.PCB-V1.3	INVENGO 2008/05/21	
File: XCRF-860-JB.Sch				

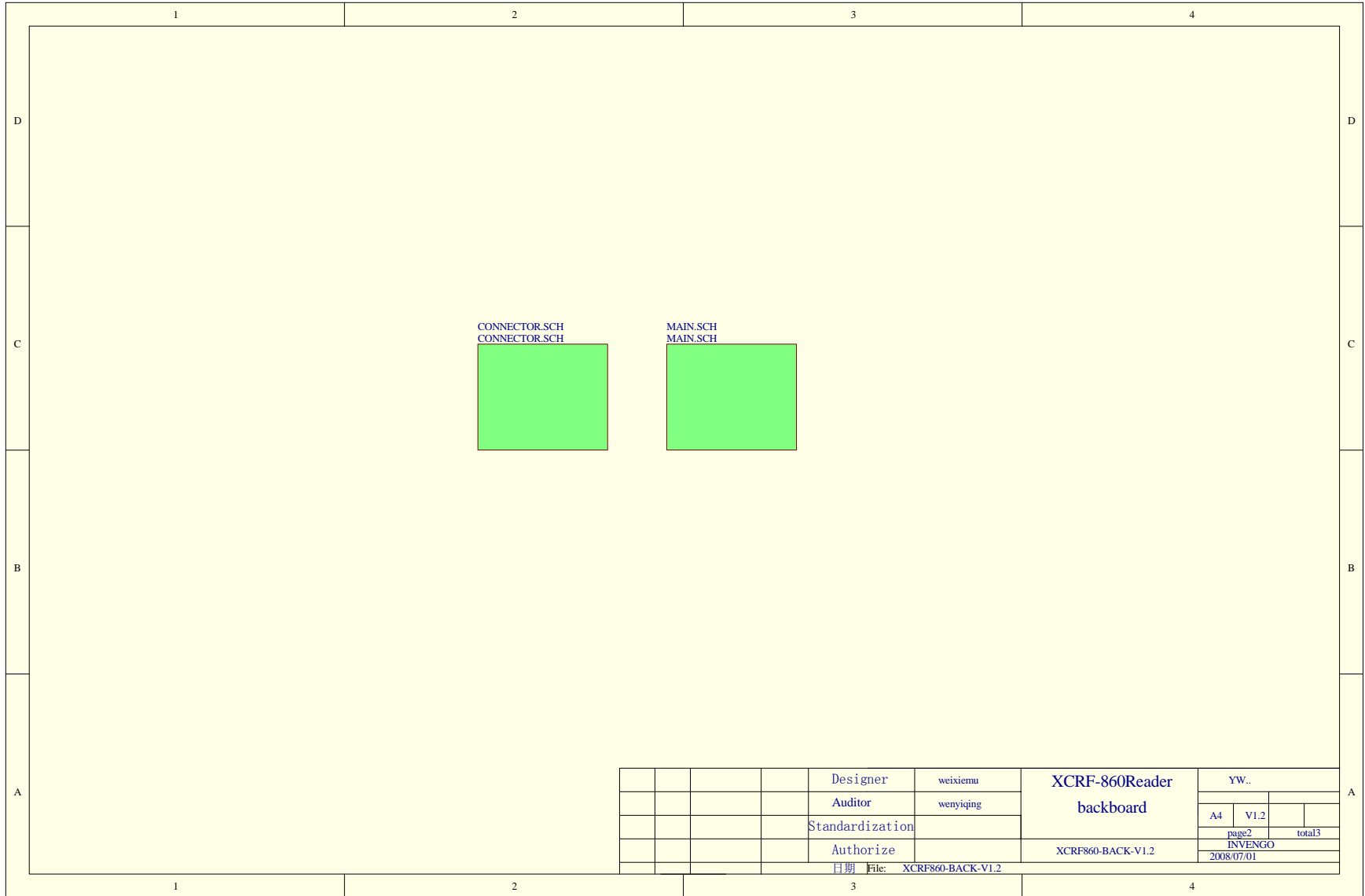

CONNECTOR.SCH  
CONNECTOR.SCH

MAIN.SCH  
MAIN.SCH

			Designer	weixiemu	XCRF-860Reader backboard	YW..	
			Auditor	wenyiqing		A4	V1.2
			Standardization			page2	total3
			Authorize		XCRF860-BACK-V1.2	INVENGO	
			日期	File: XCRF860-BACK-V1.2		2008/07/01	



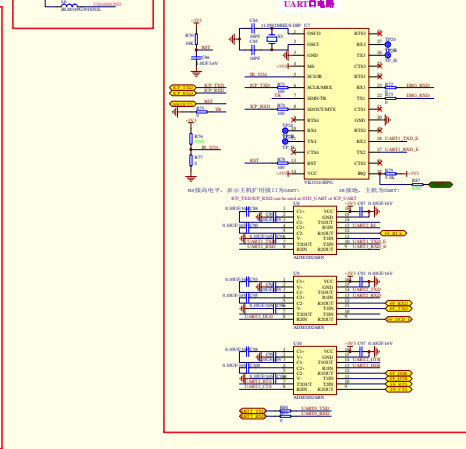
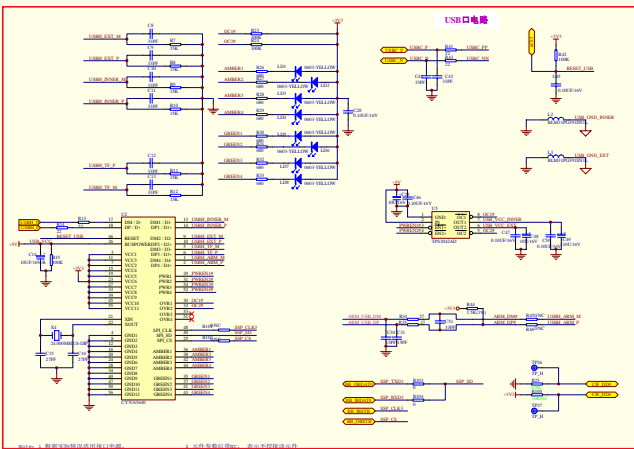
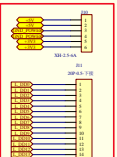
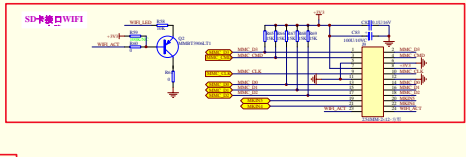
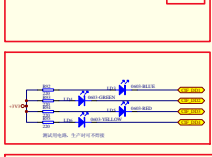
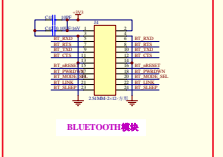
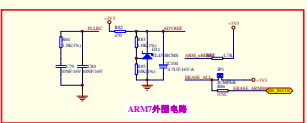
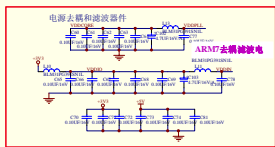
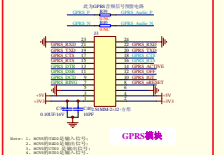
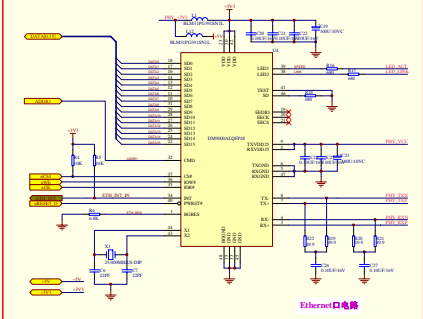
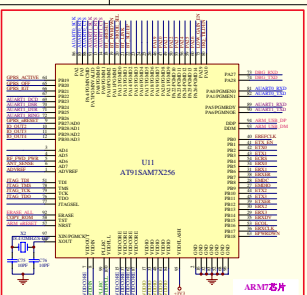
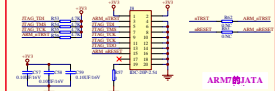
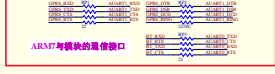
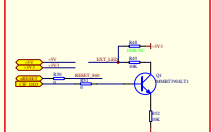
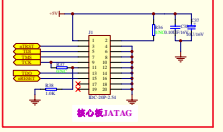
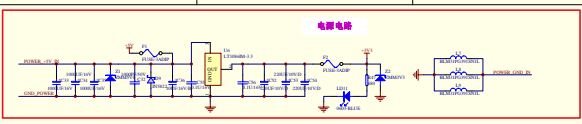
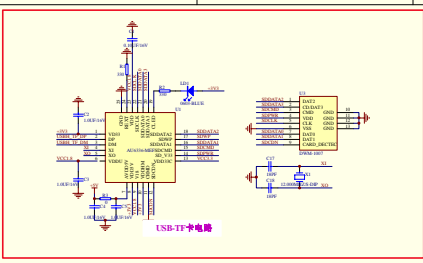

DocId: 3984	Version: 1.0	Product: XCRF-80Reader	File: 1/1
Author: 李俊	Created: 2010-10-10 10:10:10	Project: XCRF-80Reader	Page: 1/1
Rev: 1.0	Created: 2010-10-10 10:10:10	Project: XCRF-80Reader	Page: 1/1

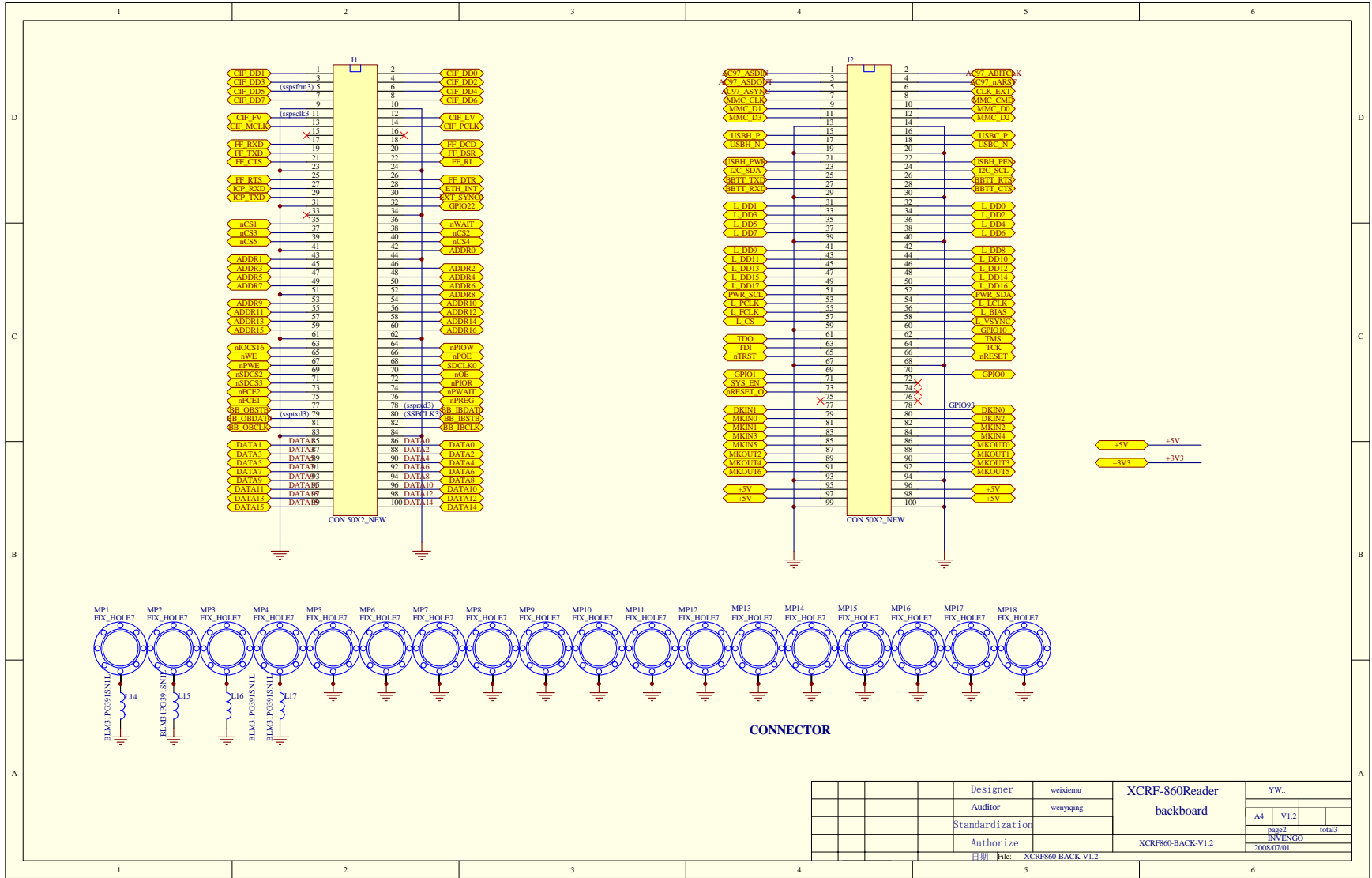

Designer	weixiema	XCRF-860Reader backboard	YW..	
Auditor	wenyiqiang		A4	V1.2
Standardization			page2	total3
Authorize		XCRF860-BACK-V1.2	2008-07-01	
日期 File: XCRF860-BACK-V1.2				

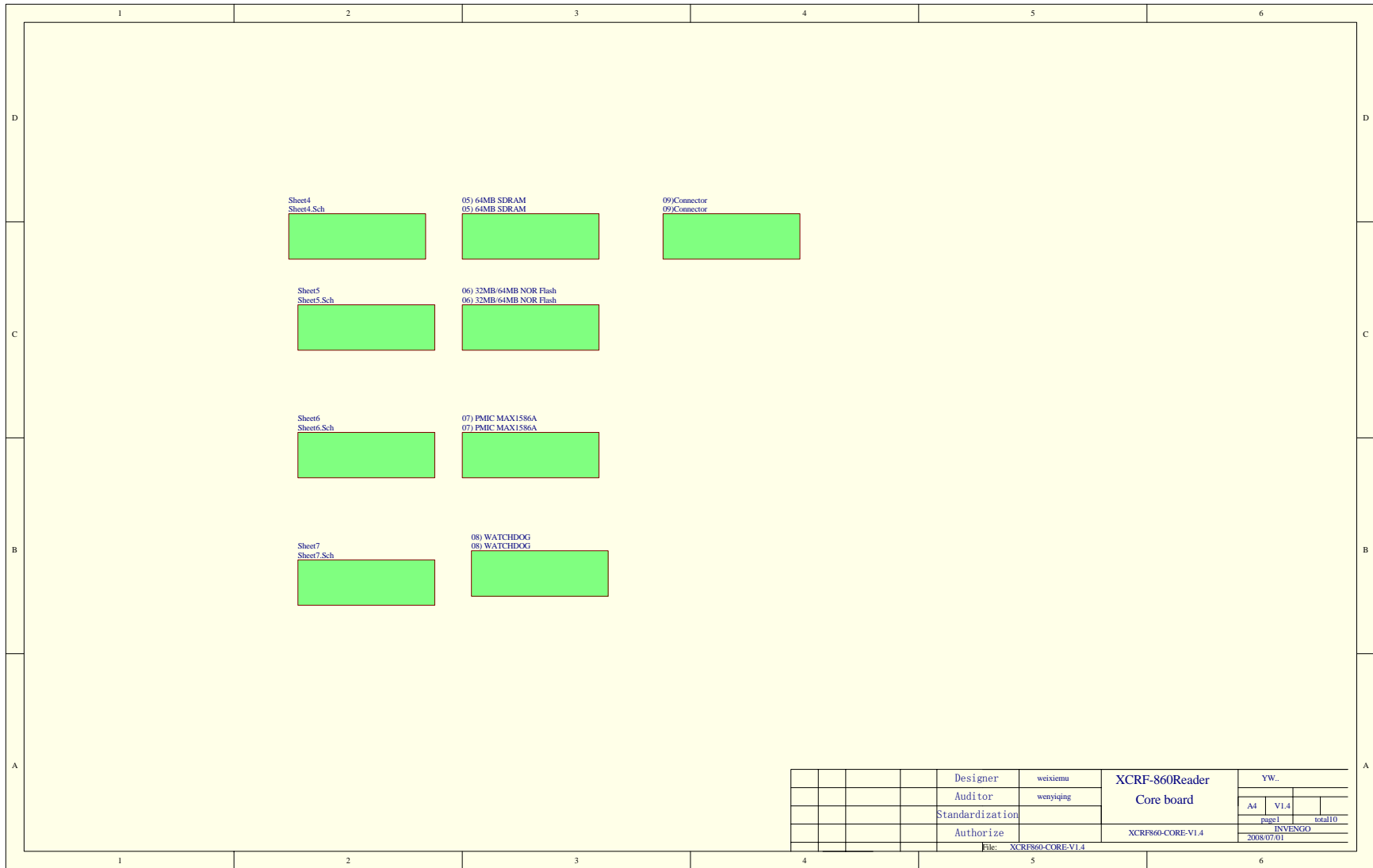

				Designer	weixiemu	XCRF-860Reader Core board	YW..	
				Auditor	wenyiqing		A4	V1.4
				Standardization			page1	total10
				Authorize		XCRF860-CORE-V1.4	2008/07/01	

File: XCRF860-CORE-V1.4

UHD PXA270 Intel's XScale Processor, PBGA360-1.0mm			
CIF_MCLK	A16	CIF_MCLK/SSPCLK/GPIO23	L_VSYNC/GPIO14
CIF_FV	B14	CIF_FV/SSPRM/GPIO24	L_CS/GPIO19
CIF_LV	A15	CIF_LV/SSFTXD/GPIO25	L_FCLK/GPIO74
CIF_PCLK	A14	CIF_PCLK/SSPRXD/GPIO26	L_LCLK/GPIO75
CIF_DD0	C13	CIF_DD0/SSPEXTCLK/GPIO27	L_PCLK/GPIO76
CIF_DD1	F19	CIF_DD1/UVS0/GPIO114	L_BIAS/GPIO77
CIF_DD2	E20	CIF_DD2/UVS2/GPIO116	L_DD0/GPIO58
CIF_DD3	E21	CIF_DD3/UVS1/GPIO115	L_DD1/GPIO59
CIF_DD4	H19	CIF_DD4/uURST/GPIO90	L_DD2/GPIO60
CIF_DD5	G19	CIF_DD5/uCLK/GPIO91	L_DD3/GPIO61
CIF_DD6	D15	CIF_D6/GPIO17	L_DD4/GPIO62
CIF_DD7	A7	CIF_DD7/GPIO12	L_DD5/GPIO63
MMC_CLK	C16	MMCCLK/GPIO32	L_DD6/GPIO64
MMC_CMD	B16	MMCCMD/GPIO112	L_DD7/GPIO65
MMC_D0	A18	MMCDAT0/GPIO92	L_DD8/GPIO66
MMC_D1	D16	MMCDAT1/GPIO99	L_DD9/GPIO67
MMC_D2	C15	MMCDAT2/GPIO110	L_DD10/GPIO68
MMC_D3	A17	MMCDAT3/GPIO111	L_DD11/GPIO69
BB_IBSTB	Y10	BB_IBSTB/GPIO84	L_DD12/GPIO70
BB_IBCLK	AB10	BB_IBCLK/GPIO83	L_DD13/GPIO71
BB_IBDAT0	AAS	BB_IBDAT0/GPIO82	L_DD14/GPIO72
BB_OBSTB	AA12	BB_OBSTB/GPIO83	L_DD15/GPIO73
BB_OBCLK	Y12	BB_OBCLK/GPIO82	L_DD16/GPIO86
BB_OBDAT0	W10	BB_OBDAT0/GPIO81	L_DD17/GPIO87
EXT_SYNC0	AS	EXT_SYNC0/GPIO11	ABITCLK/GPIO28
UIO	F20	UIO	ASDIN/GPIO29
			ASDOUT/GPIO30
			ASYNC/GPIO31
			nARST/GPIO113
			P20 L_VSYNC
			P19 L_CS
			N22 L_PCLK
			N20 L_LCLK
			N21 L_PCLK
			P21 L_BIAS
			G20 L_DD0
			H20 L_DD1
			G21 L_DD2
			F22 L_DD3
			G22 L_DD4
			J20 L_DD5
			H22 L_DD6
			K20 L_DD7
			J19 L_DD8
			K19 L_DD9
			K21 L_DD10
			J22 L_DD11
			K22 L_DD12
			L20 L_DD13
			L21 L_DD14
			L22 L_DD15
			M20 L_DD16
			M22 L_DD17
			D12 AC97_ABITCLK
			B11 AC97_ASDIN
			C11 AC97_ASDOUT
			A10 AC97_ASYNC

Designer	weisiemu	XCRF-860Reader Core board	YW.	
Auditor	wenysijing		A4	V1.4
Standardization			page2	total10
Authorize		XCRF860-CORE-V1.4	INVENGO	
			2008.07.01	
File: XCRF860-CORE-V1.4				

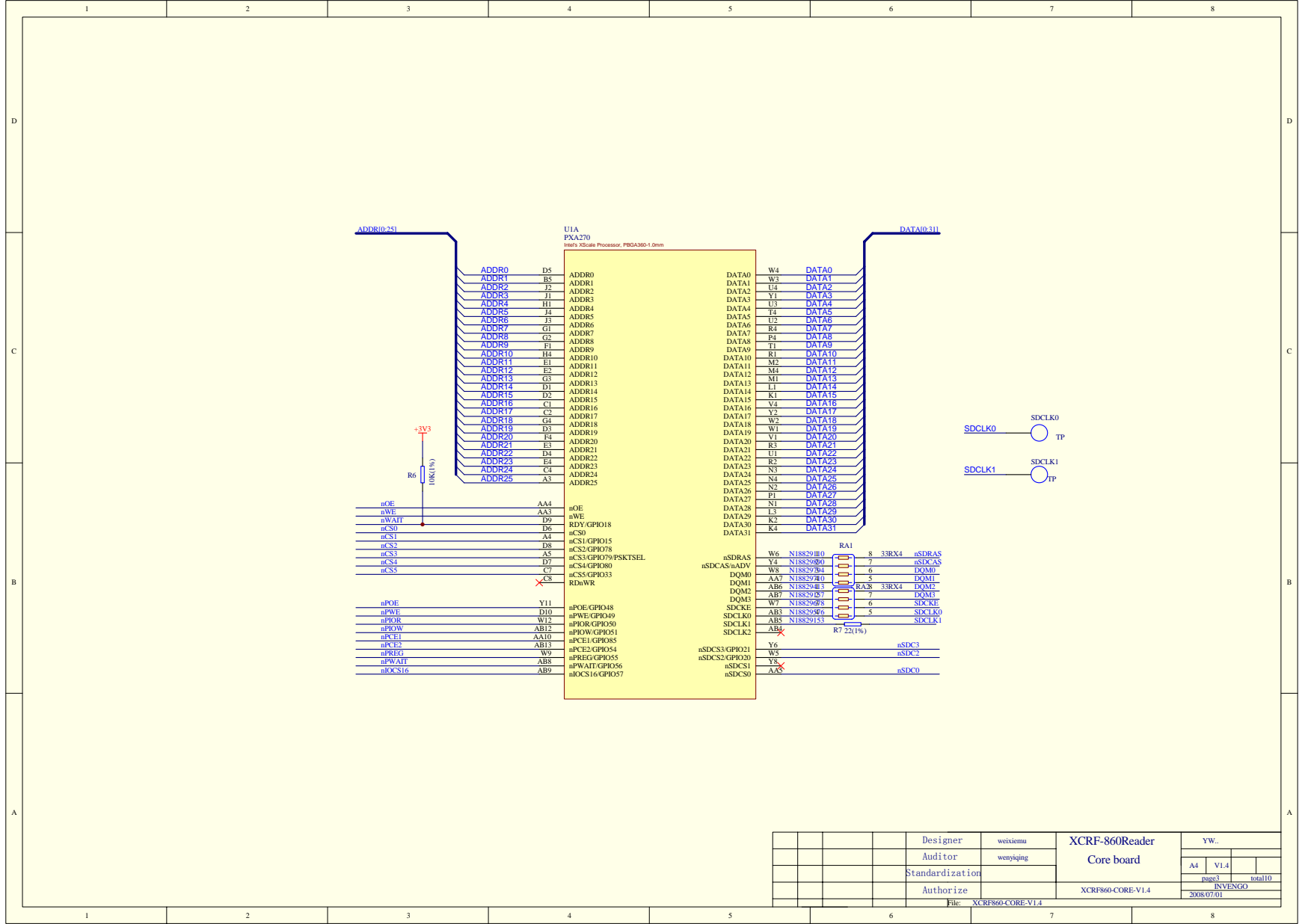

Designer	wexienn	XCRF-860Reader	YW..
Auditor	wenyiqing	Core board	A4 V1.4
Standardization			pages total10
Authorize		XCRF860-CORE-V1.4	INVENGO
			2008.07.01

File: XCRF860-CORE-V1.4

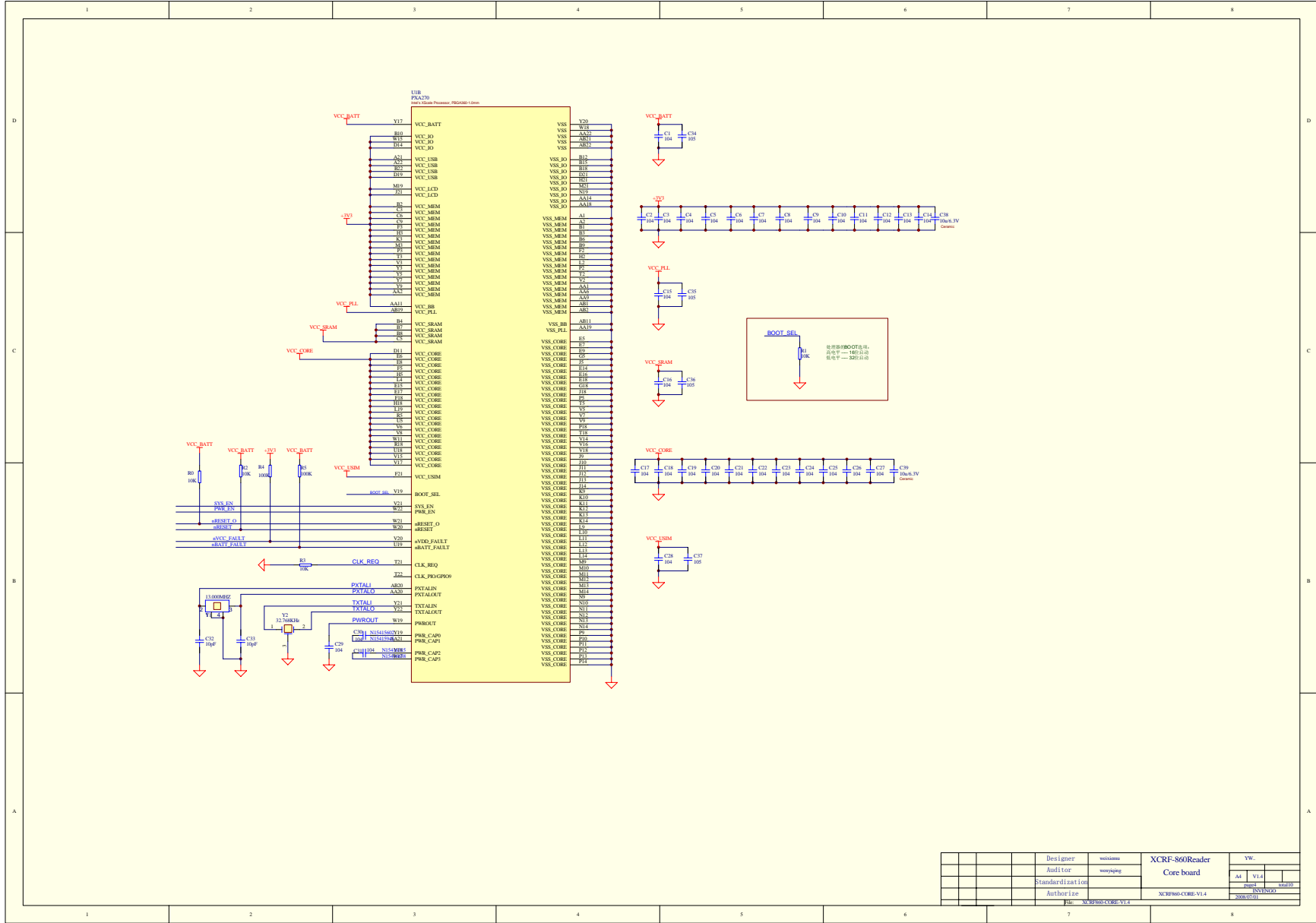

Designer	wssxmsm	XCRF-860Reader Core board	VW.	
Auditor	wssxjmg		Alt	V1.4
Standardization			REVISED	
Authorize			2020/07/01	
File: XCRF860-CORE-V1.4				

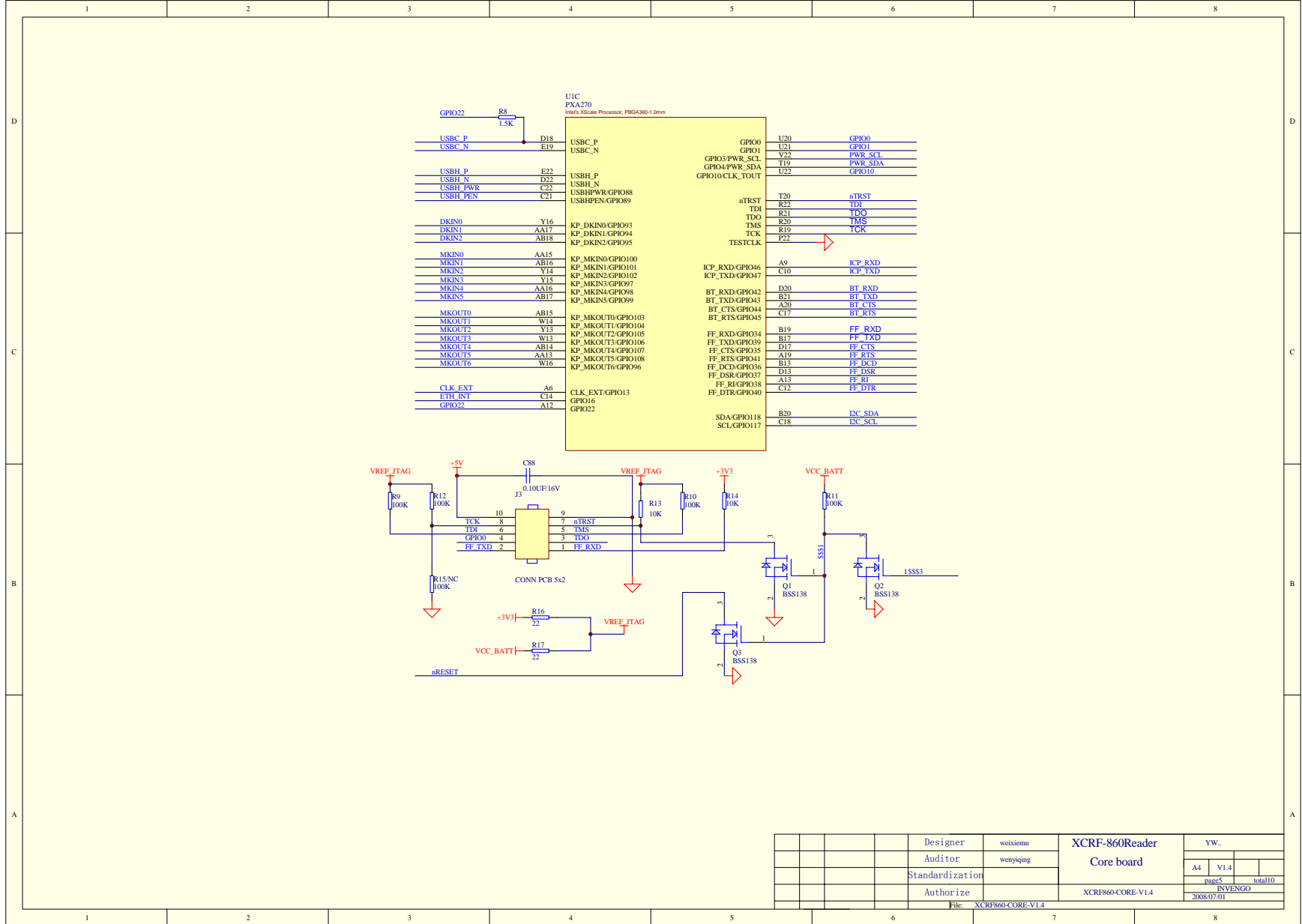

Designer	wexienn	XCRF-860Reader	YW..
Auditor	wenyijing	Core board	
Standardization			
Authorize		XCRF860-CORE-V1.4	
File: XCRF860-CORE-V1.4			
		pages: total10	
		BYVENGO	
		2008.07.01	

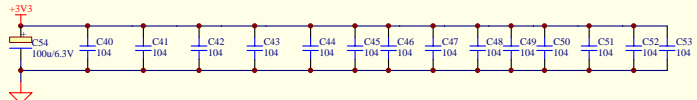
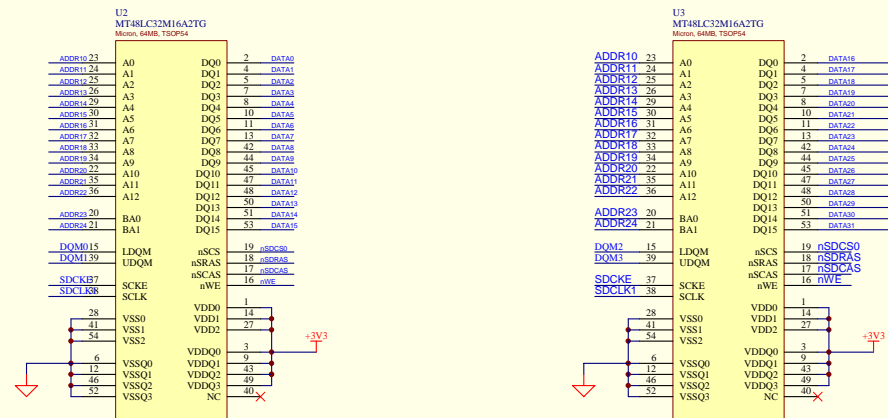

布局注意事项:  
 (1) 在SDRAM的每对电源引脚之间都放置104(0.1uF)高频旁路电容。电容要尽可能靠近引脚。  
 (2) 将两片SDRAM与处理器放置在电路板的同一面。

Designer	wexienn	XCRF-860Reader	YW..
Auditor	wenyijing	Core board	A4 V1.4
Standardization			pages total10
Authorize		XCRF860-CORE-V1.4	BYVENGO
			2008.07.01



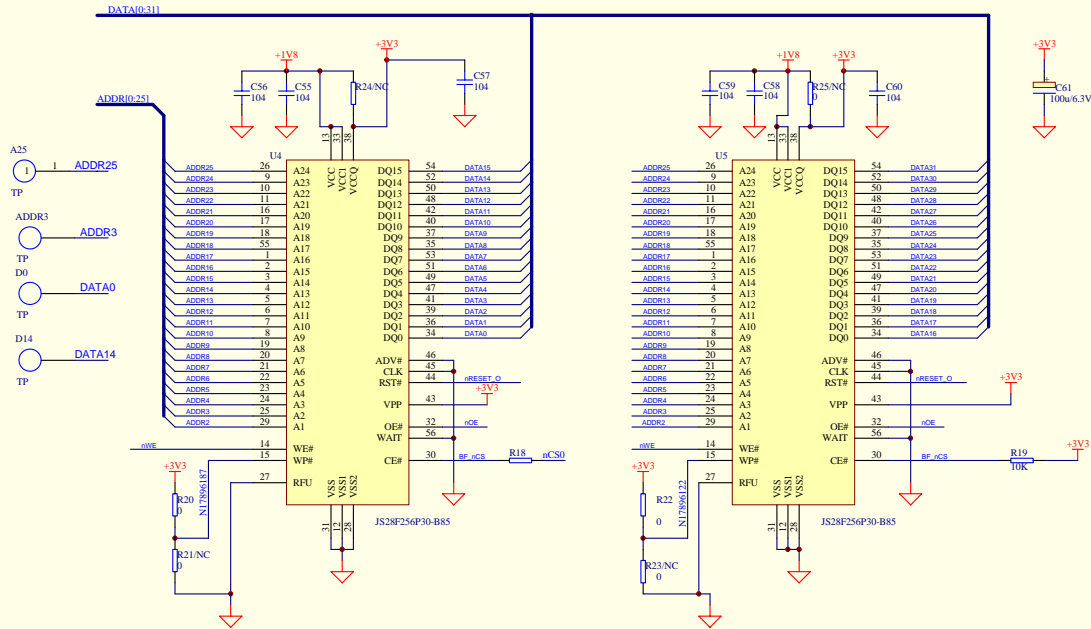

Notes:

1. 元件流水号带后缀NC，表示该元件不焊接
2. Place 104(0.1uF) capacitor to all power pins.
3. 当noflash为3.3V统一给内核及IO供电时，R24, R25需连接，此时1.8V电源不接；当3.3v及1.8v需同时提供时，R24, R25不接入。

Designer	wexienn	XCRF-860Reader	YW..	
Auditor	wenyiqing		Core board	
Standardization			A4	V1.4
Authorize			page7 total10	
			INVENGO	
			2008.07.01	

File: XCRF860-CORE-V1.4

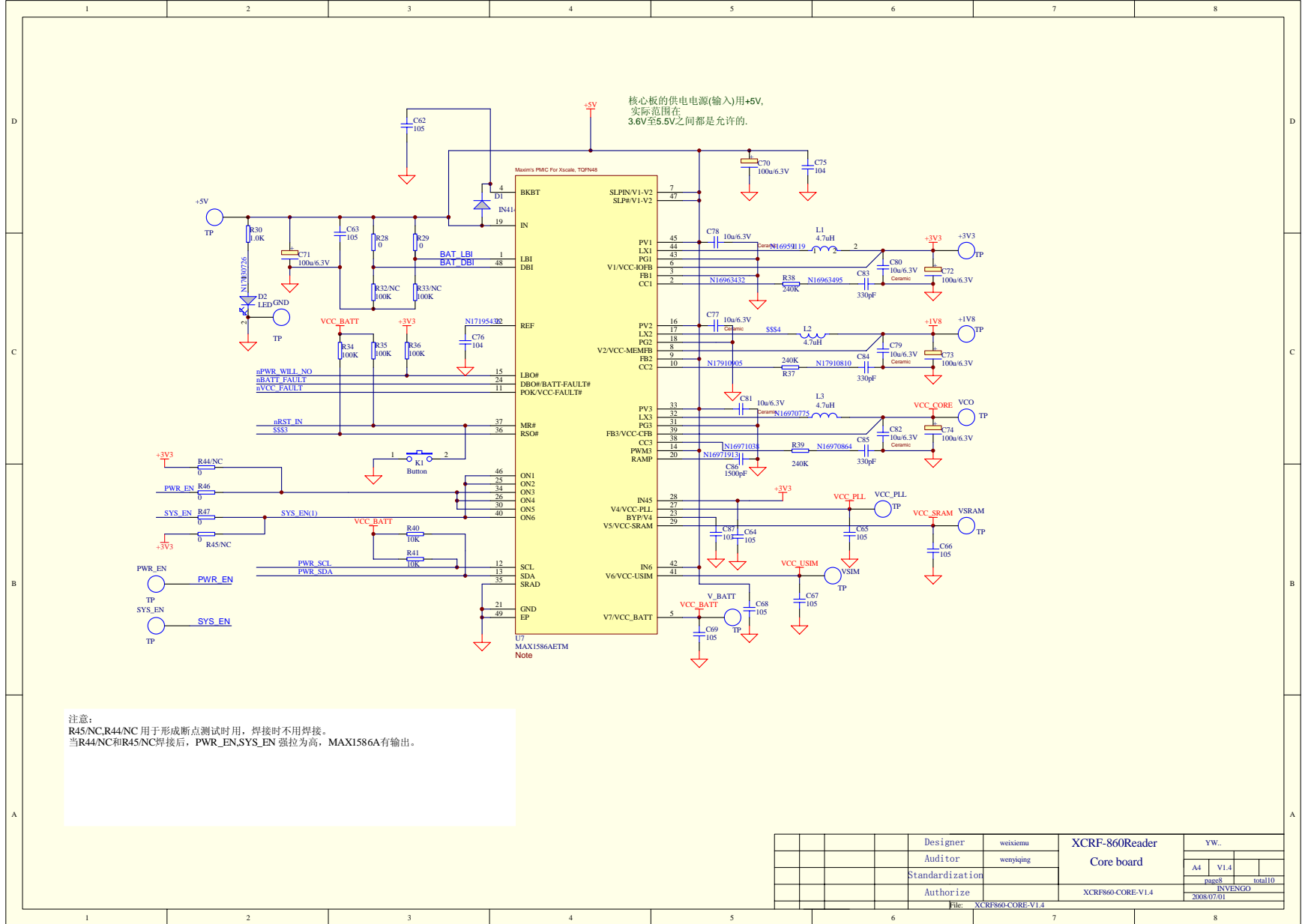

注意:  
 R45/NC,R44/NC用于形成断点测试时用, 焊接时不用焊接。  
 当R44/NC和R45/NC焊接后, PWR\_EN,SYS\_EN 强拉为高, MAX1586A有输出。

Designer	wexienn	XCRF-860Reader	YW..	
Auditor	wenyiqing		Core board	
Standardization		XCRF860-CORE-V1.4	A4	V1.4
Authorize			pages	total10
			BYVENGO	
			2008.07.01	

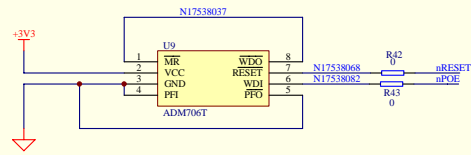

		Designer	weixian	XCRF-860Reader	YW..	
		Auditor	wenyiqing	Core board	A4	V1.4
		Standardization			total10	
		Authorize		XCRF860-CORE-V1.4	page9 INVENGO	
					200807.01	

File: XCRF860-CORE-V1.4

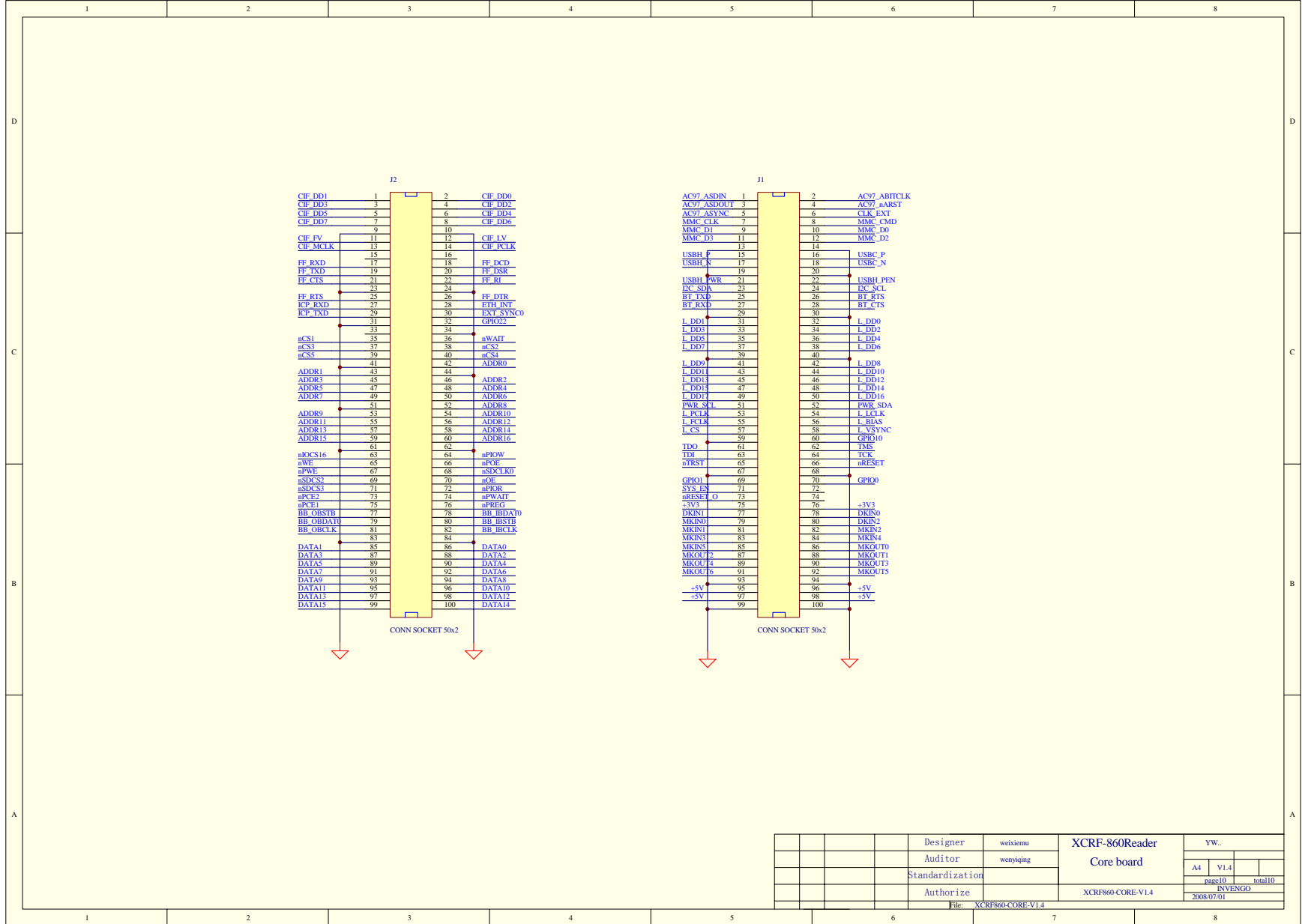

**J2**

1	CF DD1	2	CF DD0
3	CF DD3	4	CF DD2
5	CF DD5	6	CF DD4
7	CF DD7	8	CF DD6
9		10	
11	CF_FV	12	CF_LV
13	CF_MCLK	14	CF_PCLK
15		16	
17	FF_RXD	18	FF_DCD
19	FF_TXD	20	FF_DSR
21	FF_CTS	22	FF_RI
23		24	
25	FF_RTS	26	FF_DTR
27	ICP_RXD	28	ETH_INT
29	ICP_TXD	30	EXT_SYNC0
31		32	GPIO22
33		34	
35	nCS1	36	nWAIT
37	nCS3	38	nCS2
39	nCS5	40	nCS4
41		42	ADDR0
43	ADDR1	44	ADDR2
45	ADDR3	46	ADDR4
47	ADDR5	48	ADDR6
49	ADDR7	50	ADDR8
51		52	ADDR9
53	ADDR11	54	ADDR10
55	ADDR13	56	ADDR12
57	ADDR15	58	ADDR14
59		60	ADDR16
61		62	
63	nOCS16	64	nPIOW
65	nWE	66	nPOE
67	nPWE	68	nSDCLK0
69	nSDCS2	70	nOE
71	nSDCS3	72	nPIOR
73	nPCE2	74	nPWAIT
75	nPE1	76	nPRIG
77	BB_OBSTB	78	BB_IBDA10
79	BB_OBDAT0	80	BB_IBSTB
81	BB_OBCLK	82	BB_IBCLK
83		84	
85	DATA1	86	DATA0
87	DATA3	88	DATA2
89	DATA5	90	DATA4
91	DATA7	92	DATA6
93	DATA9	94	DATA8
95	DATA11	96	DATA10
97	DATA13	98	DATA12
99	DATA15	100	DATA14

**J1**

1	AC97_ASDIN	2	AC97_ABTCLK
3	AC97_ASDOUT	4	AC97_nARST
5	AC97_ASYNC	6	CLK_EXT
7	MMC_CLK	8	MMC_CMD
9	MMC_D1	10	MMC_D0
11	MMC_D3	12	MMC_D2
13		14	
15	USBH_P	16	USBC_P
17	USBH_N	18	USBC_N
19		20	
21	USBH_PWR	22	USBC_PEN
23	DC_SDA	24	DC_SCL
25	BT_TXD	26	BT_RTS
27	BT_RXD	28	BT_CTS
29		30	
31	L_DD1	32	L_DD0
33	L_DD3	34	L_DD2
35	L_DD5	36	L_DD4
37	L_DD7	38	L_DD6
39		40	
41	L_DD9	42	L_DD8
43	L_DD11	44	L_DD10
45	L_DD13	46	L_DD12
47	L_DD15	48	L_DD14
49	L_DD17	50	L_DD16
51	PWR_SCL	52	PWR_SDA
53	L_PCLK	54	L_LCLK
55	L_VCLK	56	L_VLS
57	L_CS	58	L_VSYNC
59		60	GPIO10
61	TDO	62	TMS
63	TDI	64	TCK
65	nTRST	66	nRESET
68		69	
70	GPIO	70	GPIO0
72	SYS_EN	72	
73	nRESET_O	74	
75	+3V3	76	+3V3
77	DKIN1	78	DKIN0
79	MKIN0	80	DKIN2
81	MKIN1	82	MKIN3
83	MKIN3	84	MKIN4
85	MKIN5	86	MKOUT0
87	MKOUT2	88	MKOUT1
89	MKOUT4	90	MKOUT3
91	MKOUT6	92	MKOUT5
93		94	
95	-5V	96	+5V
97	-5V	98	+5V
99		100	

	Designer	wexienn	XCRF-860Reader	YW..
	Auditor	wenyiqing	Core board	
	Standardization			A4 V1.4
	Authorize		XCRF860-CORE-V1.4	page10 total10
				BYWENGO
				20080701

File: XCRF860-CORE-V1.4