

**ELECTROMAGNETIC EMISSIONS COMPLIANCE REPORT
INTENTIONAL RADIATOR CERTIFICATION TO
FCC PART 15 SUBPART C REQUIREMENT**

OF

Reader

FCC ID:TQ4YWGIT-R5678901

MODEL No.: XCRF-804

BRAND NAME: N/A

REPORT NO: WE06070004

ISSUE DATE: July 25, 2006

Prepared for

**INVENGO INFORMATION TECHNOLOGY CO., LTD.
3/F. NO. T2-B. HIGH-TECH INDUSTRIAL PARK SOUTH,
SHENZHEN, CHINA**

Prepared by

**SHENZHEN HUATONGWEI INTERNATIONAL
INSPECTION CO., LTD**

d.b.a.

**SHENZHEN HUATONGWEI INTERNATIONAL INSPECTION CO., LTD
HUATONGWEI BUILDING, KEJI RD. 12 S., HIGH-TECH PARK,
NANSHAN DISTRICT, SHENZHEN,
GUANGDONG , P.R.CHINA**

TEL: 86-755-26748099

FAX: 86-755-26748089

VERIFICATION OF COMPLIANCE

Applicant:	Invengo Information Technology Co., LTD. 3/F. No. T2-B. High-Tech Industrial Park South, Shenzhen, China
Manufacturer	Invengo Information Technology Co., LTD. 3/F. No. T2-B. High-Tech Industrial Park South, Shenzhen, China
Product Description:	Reader
Brand Name:	N/A
Model Number:	XCRF-804
Serial Number:	N/A
File Number:	WE06070004
Date of Test:	July 16, 2006 ~ July 25, 2006

We hereby certify that:

The above equipment was tested by SHENZHEN HUA TONG WEI INTERNATIONAL INSPECTION CO., LTD. The test data, data evaluation, test procedures, and equipment configurations shown in this report were made in accordance with the procedures given in ANSI C63.4 (2003) and the energy emitted by the sample EUT tested as described in this report is in compliance with radiated emission limits of FCC Rules Part 15.247.

The test results of this report relate only to the tested sample identified in this report.

Approved By

Jimmy Li / Executive Manager
SHENZHEN HUA TONG WEI
INTERNATIONAL INSPECTION CO., LTD

Reviewed By

Tracy Qi / Testing Engineer
SHENZHEN HUA TONG WEI
INTERNATIONAL INSPECTION CO., LTD

Table of Contents

1.	GENERAL INFORMATION.....	4
1.1	Product Description	4
1.2	Related Submittal(s) / Grant (s).....	4
1.3	Test Methodology	4
1.4	Test Facility	4
2.	SYSTEM TEST CONFIGURATION	6
2.1	Configuration of Tested System.....	6
3.	Summary of Test Result.....	7
4.	DESCRIPTION OF TEST MODES.....	7
5.	PARAMETERS FOR GAME PAD	8
5.1	Conduction Emission	8
5.2	Hopping Channels.....	10
5.3	Channel Separation.....	12
5.4	20 dB Bandwidth	13
5.5	Operation Frequency	14
5.6	Peak Output Power	15
5.7	Spurious Emission at Transmitting Mode	18
5.8	Band Edge	20
5.9	Spurious Emission at Receiving Mode	22
5.10	Dwell Time	24

1 GENERAL INFORMATION

1.1 Product Description

The EUT is an short range, lower power, RFID reader and writer designed as an “ Input Device”. It is designed by way of utilizing the FHSS technology to achieve the system operation.

A major technical descriptions of EUT is described as following:

- A). Operation Frequency: Form 902 MHz – 928 MHz
total 50 channels with 500 KHz intervals
(902.7 MHz, 903.2 MHz,....., 927.2MHz)
- B). Modulation: FHSS
- C). Antenna Designation: Dedicated Antenna with 6 dB Gain
(Replace by end user is not permitted)
- D). Power Supply: AC 120 V/60 Hz

1.2 Related Submittal(s) / Grant (s)

This submittal(s) (test report) is intended for FCC ID: TQ4YWGIT-R5678901 filing to comply with Section 15.247 of the FCC Part 15, Subpart C Rules.

1.3 Test Methodology

Both conducted and radiated testing were performed according to the procedures in ANSI C63.4 (2003). Radiated testing was performed at an antenna to EUT distance 3 meters.

1.4 Test Facility

The fully anechoic chamber test site and conducted measurement facility used to collect the radiated data is located on the address of SHENZHEN HUA TONG WEI INTERNATIONAL INSPECTION CO., LTD Huatongwei Building, Keji Rd. 12 S., High-tech Park, Nanshan District, Shenzhen, Guangdong, P.R.China
The fully anechoic chamber Test Sites and the Line Conducted labs are constructed and calibrated to meet the FCC requirements in documents ANSI C63.4: 2003 and CISPR 22/EN 55022 requirements.

1.5 Special Accessories

Not available for this EUT intended for grant.

1.6 Equipment Modifications

Not available for this EUT intended for grant.

1.7 Laboratory Accreditations and Listings

The test facility is recognized, certified, or accredited by the following organizations:

CNAL-Lab Code: L1225

Shenzhen Huatongwei International Inspection Co., Ltd has been assessed and proved to be in compliance with CNAL/AC01: 2003 Accreditation Criteria for Testing and Calibration Laboratories (identical to ISO/IEC 17025: 1999 General Requirements) for the Competence of Testing and Calibration Laboratories.

A2LA-Lab Cert. No. 2243.01

Shenzhen Huatongwei International Inspection Co., Ltd, EMC Laboratory has been accredited by A2LA for technical competence in the field of electrical testing, and proved to be in compliance with ISO/IEC 17025: 1999 General Requirements for the Competence of Testing and Calibration Laboratories and any additional program requirements in the identified field of testing. Valid time is from Aug 24, 2005 to Sept 30, 2007

FCC-Registration No.: 662850

Shenzhen Huatongwei International Inspection Co., Ltd, EMC Laboratory has been registered and fully described in a report filed with the FCC (Federal Communications Commission). The acceptance letter from the FCC is maintained in our files. Registration 662850, November 17, 2003.

IC-Registration No.: 5377

The 3m Alternate Test Site of Shenzhen Huatongwei International Inspection Co., Ltd has been registered by Certification and Engineering Bureau of Industry Canada for the performance of radiated measurements with Registration No. 5377 on November 28th, 2005.

ACA

Shenzhen Huatongwei International Inspection Co., Ltd, EMC Laboratory can also perform testing for the Australian C-Tick mark as a result of our A2LA accreditation.

NEMKO-Aut. No.: ELA125

Shenzhen Huatongwei International Inspection Co., Ltd has been assessed the quality assurance system, the testing facilities, qualifications and testing practices of the relevant parts of the organization. The quality assurance system of the Laboratory has been validated against ISO/IEC 17025 or equivalent. The laboratory also fulfils the conditions described in Nemko Document NLA-10.

VCCI

The 3m Semi-anechoic chamber (12.2m×7.95m×6.7m) and Shielded Room (8m×4m×3m) of Shenzhen Huatongwei International Inspection Co., Ltd has been registered in accordance with the Regulations for Voluntary Control Measures with Registration No.: R-1920 and C-2067 respectively. Date of Registration: July 28, 2004. Valid time is until November 16, 2006.

The Shielded Room (8m×4m×3m) of Shenzhen Huatongwei International Inspection Co., Ltd has been registered in accordance with the Regulations for Voluntary Control Measures with Registration No.: T-175 respectively. Date of Registration: July 28, 2004. Valid time is until July 27, 2007.

2 System Test Configuration

2.1 Configuration of Tested System

Fig. 2-1 Configuration of Tested System

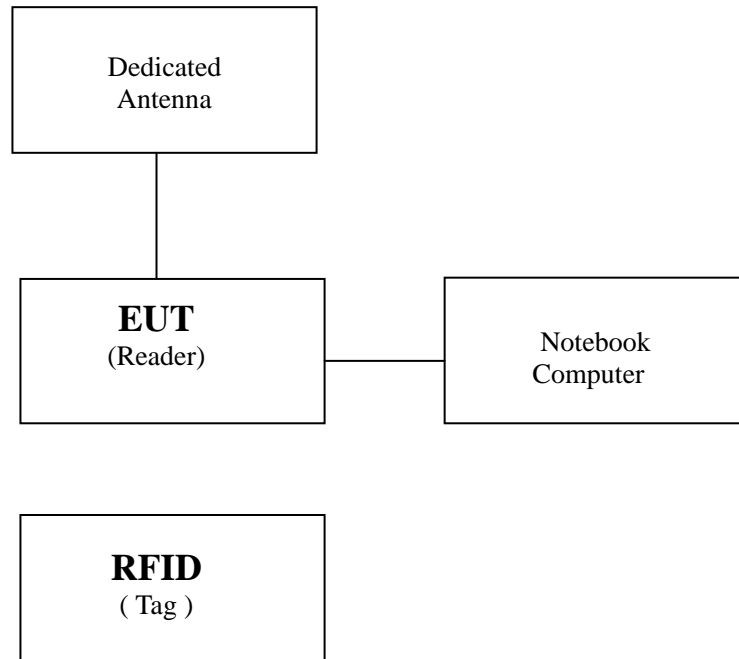

Table 2-1 Equipment Used in Tested System

Item	Equipment	Mfr/Brand	Model/Type No.	FCC ID	Series No.	Note
E-1	Reader	Invengo	XCRF-804	TQ4YWGIT-R5678901	N/A	EUT
	Notebook Computer	IBM	R50e	N/A	N/A	
	Tag	N/A	N/A	N/A	N/A	

3 Summary Of Test Results

FCC Rules	Description Of Test	EUT	Result
§ 15.247	Conduction Emission	Reader	Compliant
§ 15.247	Hopping Channels	Reader	Compliant
§ 15.247	Channel Separation	Reader	Compliant
§ 15.247	20 dB Bandwidth	Reader	Compliant
§ 15.247	Operation Frequency	Reader	Compliant
§ 15.247	Peak Output Power	Reader	Compliant
§ 15.247	Spurious Emission	Reader	Compliant
§ 15.247	Band Edge	Reader	Compliant
§ 15.247	Dwell Time	Reader	Compliant

4 Description of test modes

4.1 Continuous Transmitting Mode

4.1.1 Continuous Transmitting Mode

1. The EUT (Reader) has been set to operate continuously on the lowest, the middle and the highest operation frequency individually.
2. The EUT stays in continuous transmitting mode on the operation frequency being set.

4.2 Normal Hopping Mode

4.2.1 Continuous Transmitting Mode

1. The EUT (Reader) has been set to operate continually from the lowest operation frequency to the highest operation frequency.
2. The EUT stays in normal hopping mode on the operation frequency being set.

5 Measurement Parameters

5.1 Conduction Emissions

5.1.1 Measurement Procedure:

- 1 The equipment was set up as per the test configuration to simulate typical actual usage per the user's manual. The EUT is a tabletop system, a wooden table with a height of 0.8 meters is used and is placed on the ground plane as per ANSI C63.4.
- 2 Support equipment, if needed, was placed as per ANSI C63.4.
- 3 All I/O cables were positioned to simulate typical actual usage as per ANSI C63.4.
- 4 The EUT received AC120V/60Hz power through a Line Impedance Stabilization Network (LISN) which supplied power source and was grounded to the ground plane.
- 5 All support equipments received AC power from a second LISN, if any.
- 6 The EUT test program was started. Emissions were measured on each current carrying line of the EUT using a spectrum Analyzer / Receiver connected to the LISN powering the EUT. The LISN has two monitoring points: Line 1 (Hot Side) and Line 2 (Neutral Side). Two scans were taken: one with Line 1 connected to Analyzer / Receiver and Line 2 connected to a 50 ohm load; the second scan had Line 1 connected to a 50 ohm load and Line 2 connected to the Analyzer / Receiver.
- 7 Analyzer / Receiver scanned from 150 KHz to 30MHz for emissions in each of the test modes.
- 8 During the above scans, the emissions were maximized by cable manipulation.

5.1.2 Test SET-UP (Block Diagram of Configuration)

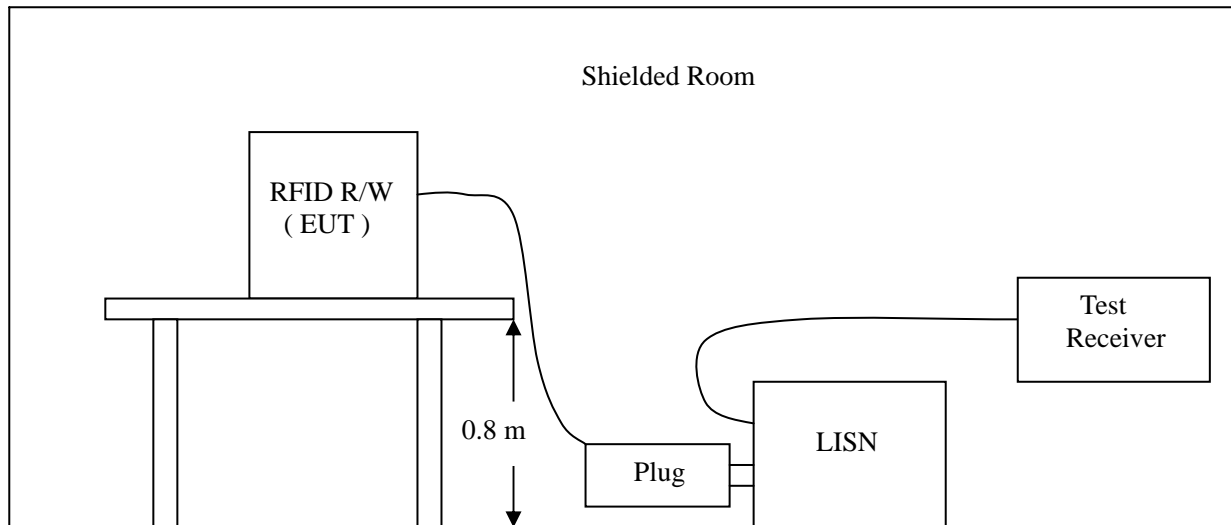

5.1.3 Measurement Equipment Used:

Conducted Emission Test Site # 3					
EQUIPMENT TYPE	MFR	MODEL NUMBER	SERIAL NUMBER	LAST CAL.	CAL DUE.
EMI TEST RECEIVER	ROHDE & SCHWARZ	ESCS30	100038	2005/11	2006/11
ARTIFICIAL MAINS	ROHDE & SCHWARZ	ESH2-Z5	100028	2005/11	2006/11
PULSE LIMITER	ROHDE & SCHWARZ	ESHSZ2	100044	2005/11	2006/11
EMI TEST SOFTWARE	ROHDE & SCHWARZ	ES-K1 V1.71	N/A	2005/11	2006/11

5.1.4 Limits And Measurement Result:

Limits and Measurement Result Of Hopping Channel		
Applicable Limits	Measurement Result	
	Test Data	Criteria
Per 15.207 Conducted Emission Limit	See as the chart below	PASS

(The chart below shows the highest readings taken from the final data)

FREQ MHz	PEAK RAW dBuV	Q.P. RAW dBuV	AVG RAW dBuV	Q.P. Limit dBuV	AVG Limit dBuV	Q.P. Margin dB	AVG Margin dB	NOTE
0.272	48.40	---	---	61.10	51.10	---	-2.70	L1
0.411	44.40	---	---	57.60	47.60	---	-3.20	L1
0.531	41.80	---	---	56.00	46.00	---	-4.20	L1
0.807	42.10	---	---	56.00	46.00	---	-3.90	L1
4.038	36.80	---	---	56.00	46.00	---	-9.20	L1
6.125	43.50	---	---	60.00	50.00	---	-6.50	L1
0.272	48.20	---	---	61.10	51.10	---	-2.90	L2
0.407	44.80	---	---	57.70	47.70	---	-2.90	L2
0.862	40.05	---	---	56.00	46.00	---	-5.95	L2
0.958	39.90	---	---	56.00	46.00	---	-6.10	L2
4.029	35.10	---	---	56.00	46.00	---	-10.90	L2
4.605	35.30	---	---	56.00	46.00	---	-10.70	L2

L1 = Line One (Hot side) / L2 = Line Two (Neutral side)

****NOTE:** “---” denotes the peak emission level was or more than 2dB below the Average limit, so no re-check anymore.

5.2 Hopping Channels

5.2.1 Measurement Procedure:

1. The EUT was placed on a turn table which is 0.8m above ground plane.
2. Set EUT as Normal Operation mode
3. Set SPA Start Frequency = 900 MHz, Stop Frequency= 930 MHz, RBW= 10 KHz, VBW= 10 KHz.
4. Set SPA Trace 1 Max hold, then View.

5.2.2 Test SET-UP (Block Diagram of Configuration)

(A) Radiated Emission Test Set-Up, Frequency Below 30MHz

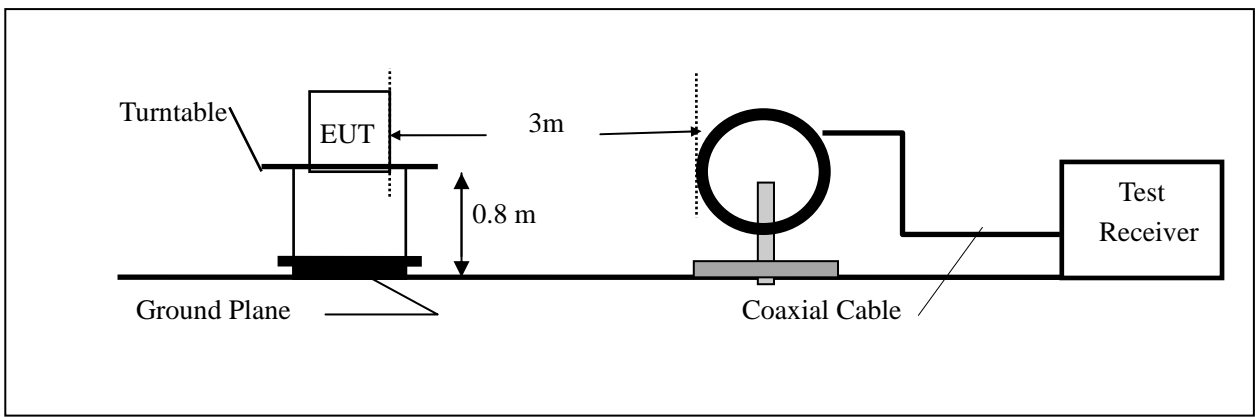

(B) Radiated Emission Test Set-Up, Frequency Below 1000MHz

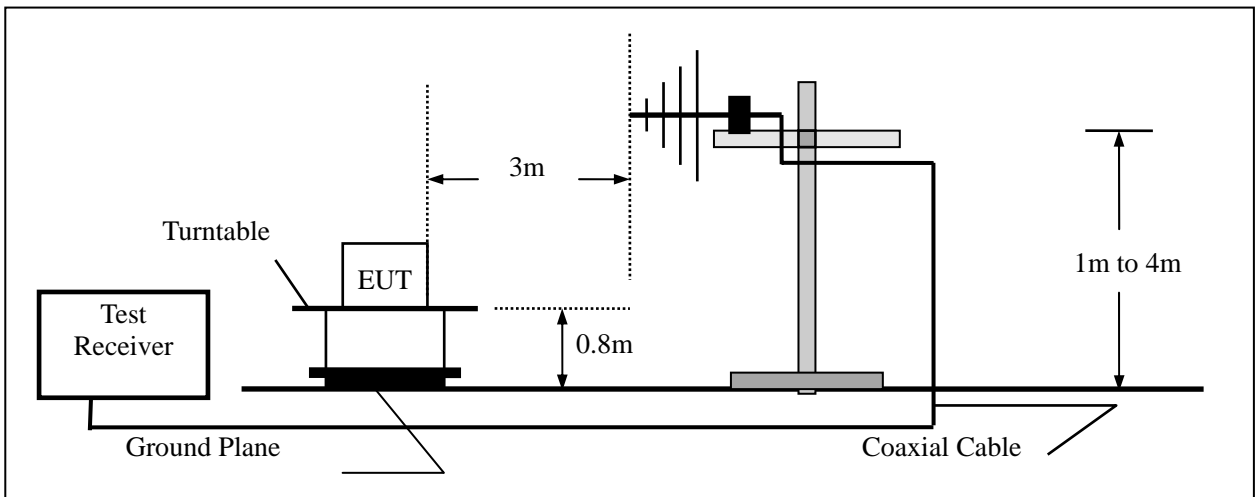

(C) Radiated Emission Test Set-Up, Frequency Above 1000MHz

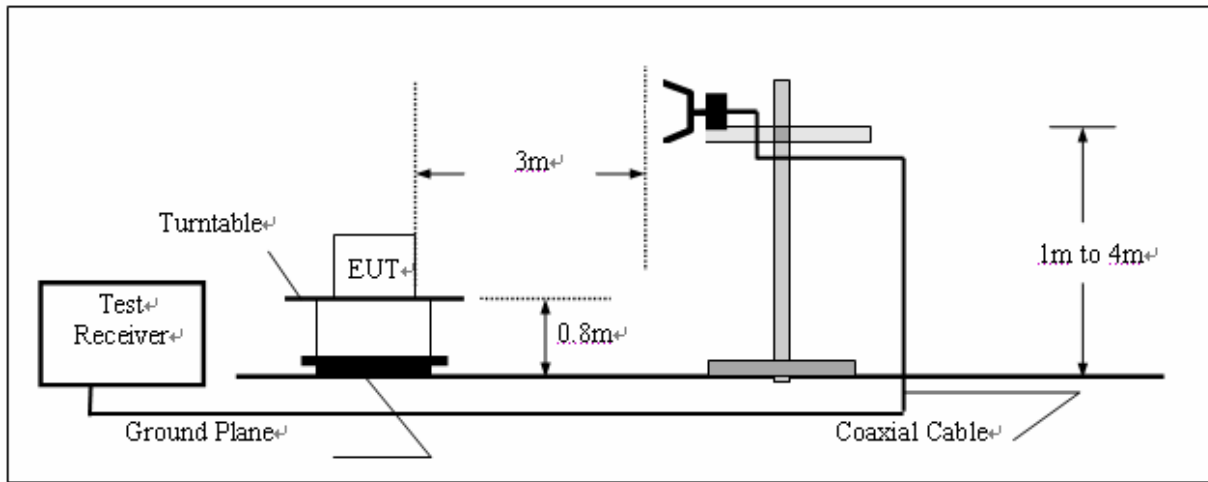

5.2.3 Measurement Equipment Used:

3/5 Anechoic Chamber Radiation Test Site # 4					
EQUIPMENT TYPE	MFR	MODEL NUMBER	SERIAL NUMBER	LAST CAL.	CAL DUE.
ULTRA-BROADBAND ANTENNA	ROHDE & SCHWARZ	HL562	100015	2005/11	2006/11
EMI TEST RECEIVER	ROHDE & SCHWARZ	ESI 26	100009	2005/11	2006/11
RF TEST PANEL	ROHDE & SCHWARZ	TS / RSP	335015/ 0017	N/A	N/A
TURNTABLE	ETS	2088	2149	N/A	N/A
ANTENNA MAST	ETS	2075	2346	N/A	N/A
EMI TEST SOFTWARE	ROHDE & SCHWARZ	ES-K1 V1.71	N/A	2005/11	2006/11

5.2.4 Limits And Measurement Result:

Limits and Measurement Result Of Hopping Channel		
Applicable Limits	Measurement Result	
	Test Data	Criteria
Per 15.247 (a)(1)(i) At least 50 hopping Frequencies for 20 dB channel bandwidth less than 250 KHz	Total 50 Channel	PASS

5.3 Channel Separation

5.3.1 Measurement Procedure:

1. The EUT was placed on a turn table which is 0.8m above ground plane.
2. Set EUT as Normal Operation mode
3. Set Start Frequency = 901 MHz, Stop Frequency = 905 MHz, RBW= 10 KHz, VBW= 10 KHz
4. Set SPA Trace 1 Max hold, then View.

5.3.2 Test SET-UP (Block Diagram of Configuration)

The same as described in Section 5.2.2

5.3.3 Measurement Equipment Used:

The same as described in Section 5.2.3

5.3.4 Limits And Measurement Result:

Limits and Measurement Result Of Channel Separation		
Applicable Limits	Measurement Result	
	Test Data	Criteria
Per 15.247 (a)(1) At least 25 KHz or 20 dB bandwidth of the hopping Channel, whichever is greater	504 KHz	PASS

5.4 20 dB Bandwidth

5.4.1 Measurement Procedure

1. The EUT was placed on a turn table which is 0.8m above ground plane.
2. Set EUT as continuous transmitting mode
3. Set SPA Center Frequency = Operation Frequency, RBW, VBW= 10 KHz, Span =500 KHz.
4. Set SPA Trace 1 Max hold, then View.

5.4.2 Test SET-UP (Block Diagram of Configuration)

The Same as described in Section 5.2.2

5.4.3 Measurement Equipment Used:

The same as described in Section 5.2.3

5.4.4 Limits And Measurement Results:

Limits and Measurement Result Of 20 dB Bandwidth For The Top Channel		
Applicable Limits	Measurement Result	
	Test Data	Criteria
Per 15.247 (a)(1)(i) The maximum 20 dB bandwidth of the hopping channel is 500 KHz	28.0 KHz	PASS

Limits and Measurement Result Of 20 dB Bandwidth For The Middle Channel		
Applicable Limits	Measurement Result	
	Test Data	Criteria
Per 15.247 (a)(1)(i) The maximum 20 dB bandwidth of the hopping channel is 500 KHz	27.4 KHz	PASS

Limits and Measurement Result Of 20 dB Bandwidth For The Bottom Channel		
Applicable Limits	Measurement Result	
	Test Data	Criteria
Per 15.247 (a)(1)(i) The maximum 20 dB bandwidth of the hopping channel is 500 KHz	27.2 KHz	PASS

5.5 Operation Frequency

5.5.1 Measurement Procedure:

1. The EUT was placed on a turn table which is 0.8m above ground plane.
2. Set EUT as Continuous Transmitting Mode.
3. Set SPA Center Frequency = Bottom Channel for Fl measurement (Top Channel for Ft measurement), RBW= 10 KHz, VBW= 10 KHz, Span= 100 KHz
4. Set SPA Trace 1 Max hold, then View.

5.5.2 Test SET-UP (Block Diagram of Configuration)

The same as described in Section 5.2.2

5.5.3 Measurement Equipment Used:

The same as described in Section 5.2.3

5.5.4 Limits And Measurement Result:

Limits and Measurement Result Of Operation Frequency		
Applicable Limits	Measurement Result	
	Test Data	Criteria
Per 15.247 The operation frequencies shall lie wholly within 902 MHz to 928 MHz	Fl=902.7054 MHz Ft=927.2045 MHz	PASS

Notes:

Fl means the lowest band edge frequency of the bottom channel; Ft means the highest band edge frequency of the top channel

5.6 Peak Output Power

5.6.1 Measurement Procedure:

Conducted measurement:

- 1 Detached the dedicated antenna
- 2 Connect the end output of the transmitting cable to the measurement instruments through an 20 dB attenuator.

Radiated measurement:

- 3 On a test site, the EUT shall be placed on a turntable
- 4 The test antenna shall be oriented initially for vertical polarization located 3m from the EUT to correspond to the transmitter.
- 5 The output of the antenna shall be connected to the measuring receiver and either a peak or quasi-peak detector was used for the measurement as indicated on the report. The detector selection is based on how close the emission level was approaching the limit.
- 6 The transmitter shall be switched on; if possible, without the modulation and the measurement receiver shall be tuned to the frequency of the transmitter under test.
- 7 The test antenna shall be raised and lowered through the specified range of height until the measuring receiver detects a maximum signal level.
- 8 The transmitter shall than be rotated through 360° in the horizontal plane, until the maximum signal level is detected by the measuring receiver.
- 9 The test antenna shall be raised and lowered again through the specified range of height until the measuring receiver detects a maximum signal level.
- 10 The maximum signal level detected by the measuring receiver shall be noted.
- 11 Replace the antenna with a proper Antenna (substitution antenna).
- 12 The substitution antenna shall be oriented for vertical polarization and, if necessary, the length of the substitution antenna shall be adjusted to correspond to the frequency of transmitting.
- 13 The substitution antenna shall be connected to a calibrated signal generator.
- 14 If necessary, the input attenuator setting of the measuring receiver shall be adjusted in order to increase the sensitivity of the measuring receiver.
- 15 The test antenna shall be raised and lowered through the specified range of the height to ensure that the maximum signal is received.
- 16 The input signal to substitution antenna shall be adjusted to the level that produces a level detected by the measuring receiver, that is equal to the level noted while the transmitter radiated power was measured, corrected for the change of input attenuation setting of the measuring receiver.

- 17 The input level to the substitution antenna shall be recorded as power level in dBm, corrected for any change of input attenuator setting of the measuring receiver.
- 18 The measurement shall be repeated with the test antenna and the substitution antenna oriented for horizontal polarization.
- 19 The measure of the effective radiated power is the larger of the two levels recorded, at the input to the substitution antenna, corrected for the gain of the substitution antenna .

5.6.2 Test SET-UP (Block Diagram of Configuration)

Substitution Method (Radiated Emission)

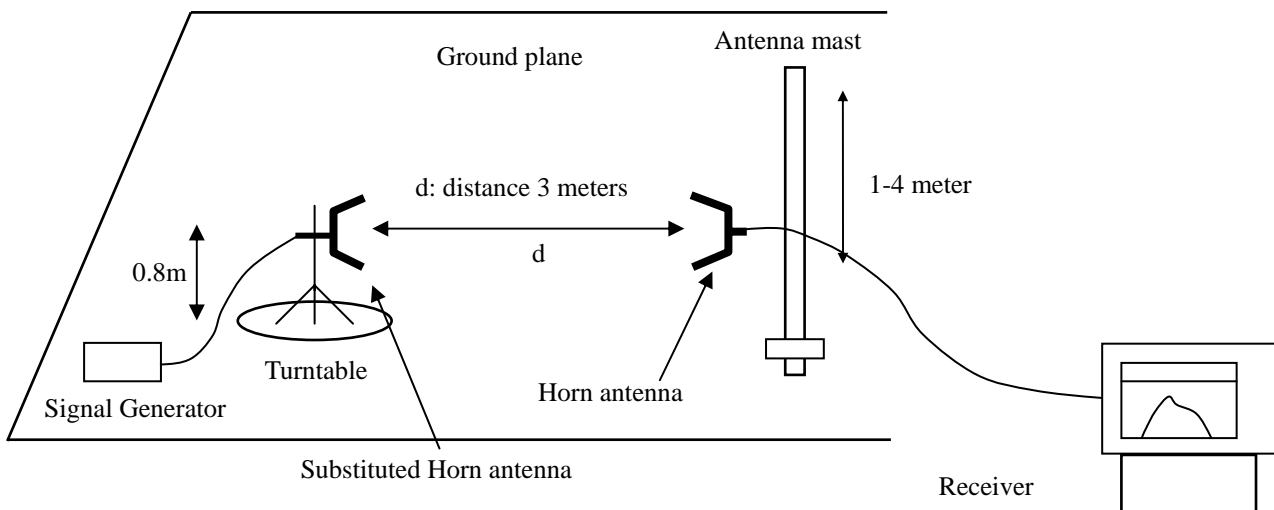
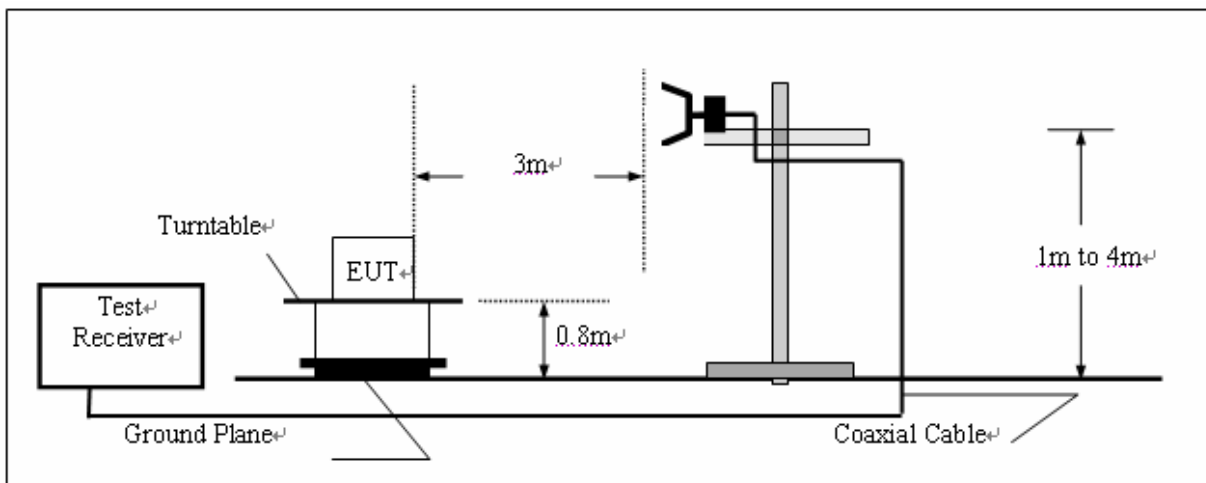

5.6.3 Measurement Equipment Used:

3/5 Anechoic Chamber Radiation Test Site # 4					
EQUIPMENT TYPE	MFR	MODEL NUMBER	SERIAL NUMBER	LAST CAL.	CAL DUE.
ULTRA-BROADBAND ANTENNA	ROHDE & SCHWARZ	HL562	100015	2005/11	2006/11
EMI TEST RECEIVER	ROHDE & SCHWARZ	ESI 26	100009	2005/11	2006/11
RF TEST PANEL	ROHDE & SCHWARZ	TS / RSP	335015/ 0017	N/A	N/A
TURNTABLE	ETS	2088	2149	N/A	N/A
ANTENNA MAST	ETS	2075	2346	N/A	N/A
EMI TEST SOFTWARE	ROHDE & SCHWARZ	ES-K1 V1.71	N/A	2005/11	2006/11

5.6.4 Limits And Measurement Result:

Limits and Measurement Result Of Peak Output Power(Conducted)		
Applicable Limits	Measurement Result	
	Test Data	Criteria
Per 15.247 (b)(2) The maximum conducted peak output power is 1 W (30 dBm)	Pt= 29.39 dBm	PASS
	Pm=29.61 dBm	PASS
	Pl=29.88 dBm	PASS

Limits and Measurement Result Of Peak Output Power(Radiated)		
Applicable Limits	Measurement Result	
	Test Data	Criteria
Per 15.247 (b)(4)	Pt= 31.56 dBm	PASS
	Pm=32.92 dBm	PASS
	Pl=33.93 dBm	PASS

5.7 Spurious Emission At Transmitting mode

5.7.1 Measurement Procedure:

The same as described in section 5.6.1

5.7.2 Test SET-UP (Block Diagram of Configuration)

Substitution method (Radiation Emission below 1 GHz)

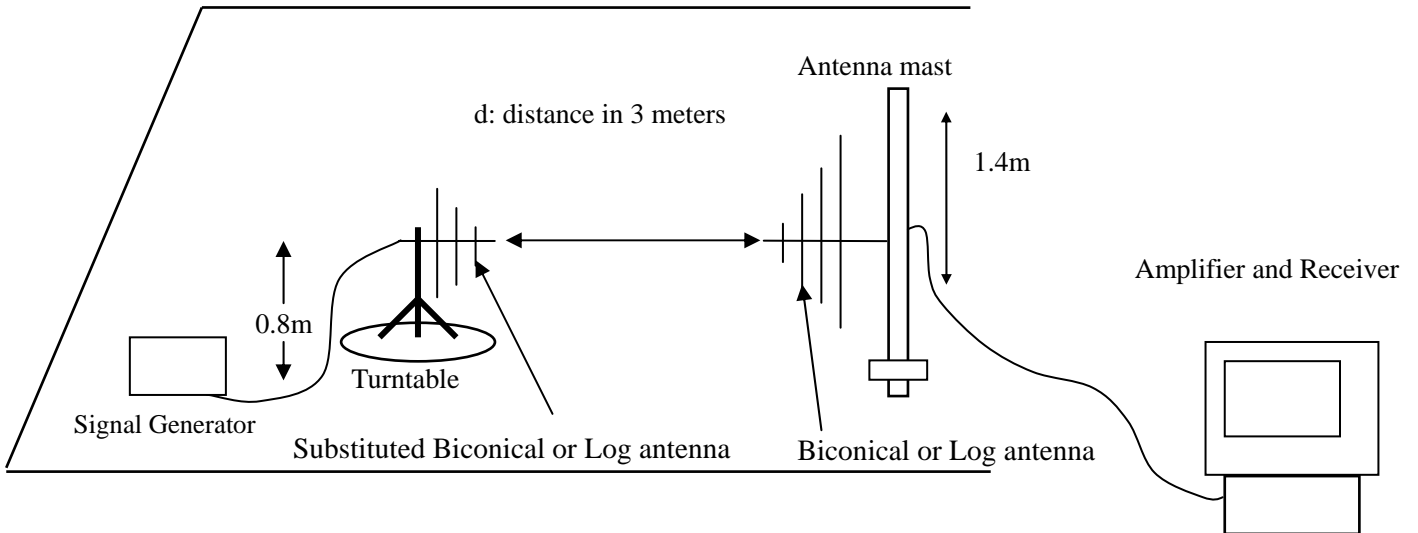
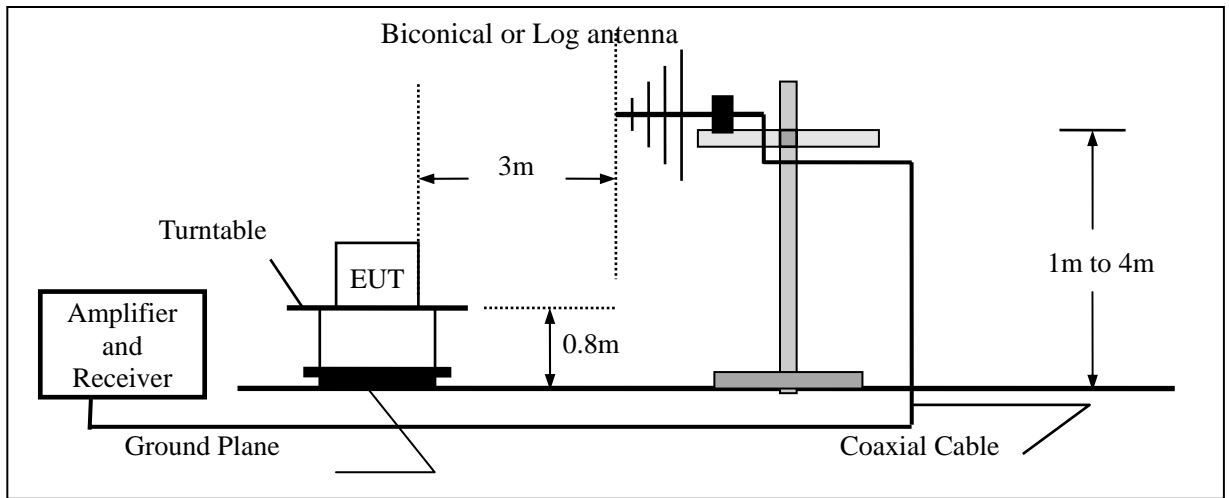

Substitution method (Radiation Emission Above 1 GHz)

The same as described in section 5.6.2

5.7.3 Measurement Equipment Used:

3/5 Anechoic Chamber Radiation Test Site # 4					
EQUIPMENT TYPE	MFR	MODEL NUMBER	SERIAL NUMBER	LAST CAL.	CAL DUE.
ULTRA-BROADBAND ANTENNA	ROHDE & SCHWARZ	HL562	100015	2005/11	2006/11
EMI TEST RECEIVER	ROHDE & SCHWARZ	ESI 26	100009	2005/11	2006/11
RF TEST PANEL	ROHDE & SCHWARZ	TS / RSP	335015/ 0017	N/A	N/A
TURNTABLE	ETS	2088	2149	N/A	N/A
ANTENNA MAST	ETS	2075	2346	N/A	N/A
EMI TEST SOFTWARE	ROHDE & SCHWARZ	ES-K1 V1.71	N/A	2005/11	2006/11

5.7.4 Limits And Measurement Result:

Limits and Measurement Result Of Spurious Emission		
Applicable Limits	Measurement Result	
	Test Data	Criteria
<p>Per 15.247 (c)</p> <p>In any 100 KHz bandwidth outside the frequency band in which the spread spectrum intentional radiator is operating, the radio frequency power that is produce by the intentional radiator shall be at least 20 dB below that in 100KHz bandwidth within the band that contains the highest level of the desired power.</p> <p>In addition, radiation emissions which fall in the restricted bands, as defined in §15.205(a), must also comply with the radiated emission limits specified in§15.209(a)</p>	See as the chart Below	PASS

Frequency (MHz)	Reading level (dBuV)	Antenna Polarization	S.G. (dBm)	Cable loss (dB)	Ant.Gain (dB)	Emission level (dBm)	Limit (dBm)	Margin (dB)
Others	--	V	--					
Others	--	H	--					

Remark:

- (1) Corrected Power (dBm) = SG O/P-Cable + Ant Gain
- (2) Measuring frequencies from 30 MHz to the 25 GHz.
- (3) Data of measurement within this frequency range shown “ -- ” in the table above means the reading of emissions are attenuated more than 20dB below the permissible limits or the field strength is too small to be measured.

5.8 BAND EDGE**5.8.1 Measurement Procedure:**

1. The EUT was placed on a turn table which is 0.8m above ground plane.
2. Set EUT as Continuous Transmitting Mode.
3. Set SPA Center Frequency = Bottom Channel for lowest frequency band edge (Top Channel for highest frequency band edge) RBW= 10 KHz, VBW= 10 KHz
4. Set SPA Trace 1 Max hold, then View.

5.8.2 Test SET-UP (Block Diagram of Configuration)

The same as described in section 5.2.2

5.8.3 Measurement Equipment Used:

The same as described in section 5.2.3

5.8.4 Limits And Measurement Result:

Limits and Measurement Result Of Band Edge		
Applicable Limits	Measurement Result	
	Test Data	Criteria
Per 15.247 (c) In any 100 KHz bandwidth outside the frequency band in which the spread spectrum intentional radiator is operating, the radio frequency power that is produce by the intentional radiator shall be at least 20 dB below that in 100 KHz bandwidth within the band that contains the highest level of the desired power.	See the test plots attached below	PASS

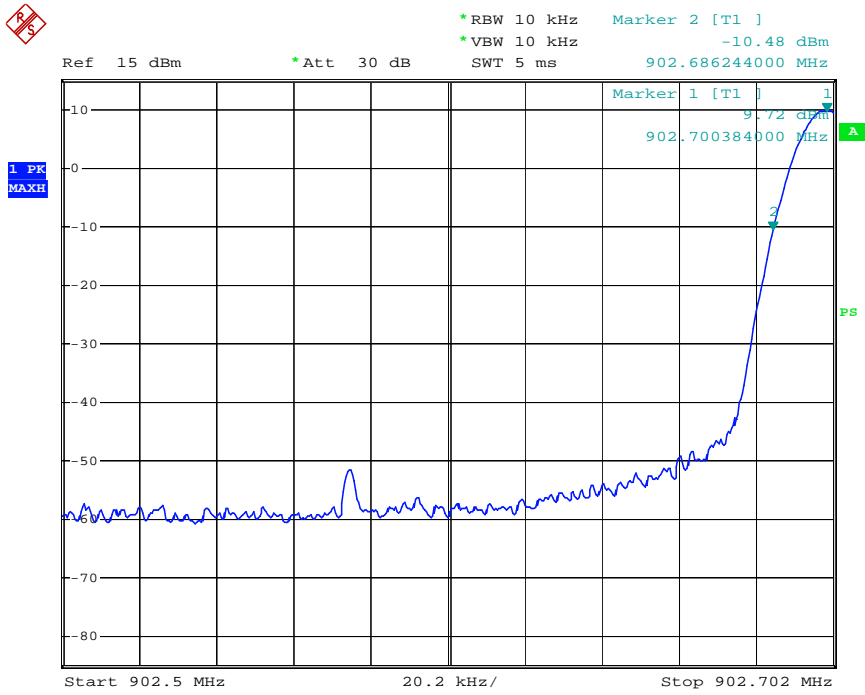

Date: 26.JUL.2006 11:29:16

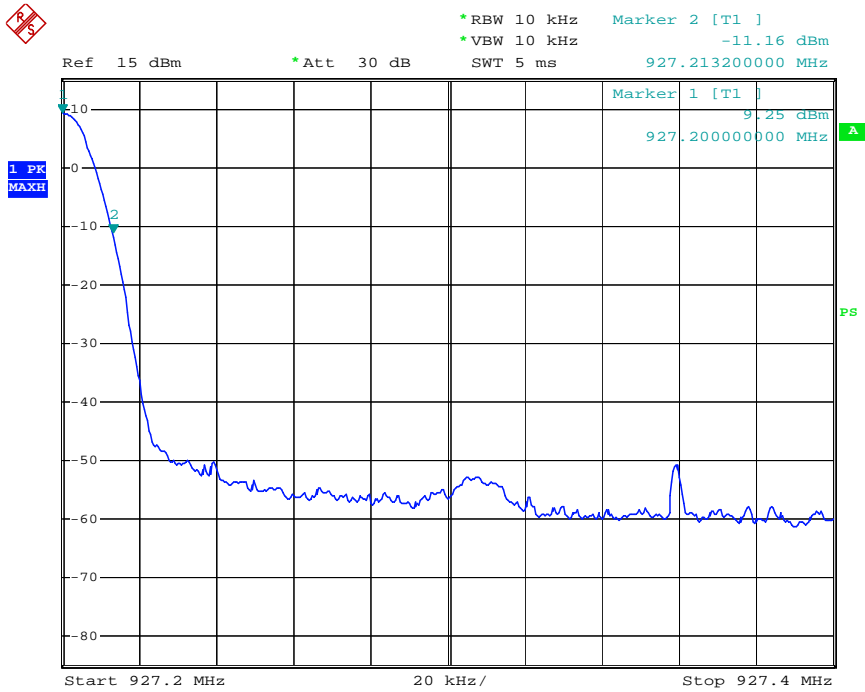

Date: 26.JUL.2006 11:34:13

5.9 Spurious Emission At Receiving Mode

5.9.1 Measurement Procedure:

- 1 The equipment was set up as per the test configuration to simulate typical actual usage per the user's manual. When the EUT is a tabletop system, a wooden turntable with a height of 0.8 meters is used which is placed on the ground plane as per ANSI C63.4 (see Test Facility for the dimensions of the ground plane used). When the EUT is a floor-standing equipment, it is placed on the ground plane which has a 3-12 mm non-conductive covering to insulate the EUT from the ground plane.
- 2 Support equipment, if needed, was placed as per ANSI C63.4.
- 3 All I/O cables were positioned to simulate typical actual usage as per ANSI C63.4.
- 4 The EUT received DC3V from the adapter, and the adapter received AC120V/60Hz power through the outlet socket under the turntable. All support equipments received AC 120V/60Hz power from socket under the turntable, if any.
- 5 The antenna was placed at 10 meter away from the EUT as stated in CISPR 22. The antenna connected to the Analyzer via a cable and at times a pre-amplifier would be used.
- 6 The Analyzer / Receiver quickly scanned from 30MHz to 1000MHz. The EUT test program was started. Emissions were scanned and measured rotating the EUT to 360 degrees and positioning the antenna 1 to 4 meters above the ground plane, in both the vertical and the horizontal polarization, to maximize the emission reading level.

5.9.2 Test SET-UP (Block Diagram of Configuration)

The same as described in section 5.2.2

5.9.3 Measurement Equipment Used:

3/5 Anechoic Chamber Radiation Test Site # 4					
EQUIPMENT TYPE	MFR	MODEL NUMBER	SERIAL NUMBER	LAST CAL.	CAL DUE.
ULTRA-BROADBAND ANTENNA	ROHDE & SCHWARZ	HL562	100015	2005/11	2006/11
EMI TEST RECEIVER	ROHDE & SCHWARZ	ESI 26	100009	2005/11	2006/11
RF TEST PANEL	ROHDE & SCHWARZ	TS / RSP	335015/ 0017	N/A	N/A
TURNTABLE	ETS	2088	2149	N/A	N/A
ANTENNA MAST	ETS	2075	2346	N/A	N/A
EMI TEST SOFTWARE	ROHDE & SCHWARZ	ES-K1 V1.71	N/A	2005/11	2006/11

5.9.4 Limits And Measurement Result:

Limits and Measurement Result Of Spurious Emission		
Applicable Limits	Measurement Result	
	Test Data	Criteria
§ 15.209 shall apply	See as the chart below	PASS

Operation Mode: Receiving Mode Test Date : September 29, 2005
 Temperature : 25 °C Test By: Jimmy Zhang
 Humidity : 59 % Pol: Vertical & Horizontal

Freq. (MHz)	Ant.Pol. H/V	DetectorMode (PK/AV)	Reading (dBuV)	Ant./CL/ Amp. CF(dB)	Actual FS (dBuV/m)	Limit3m (dBuV/m)	Safe Margin (dB)
Below 1 GHz	V	Peak	---				At least 20
Below 1 GHz	H	Peak	---				dB down
Above 1 GHz	V	Peak	---				than the
Above 1 GHz	H	Peak	---				Limit

Remark:

- (1) Measuring frequencies from 25 MHz to the 10 GHz.
- (2) Datum of measurement within this frequency range shown “--- ” in the table above means the reading of emissions are attenuated more than 20dB below the permissible limits or the field strength is too small to be measured.
- (3) The IF bandwidth of EMI Test Receiver between 25MHz to 1GHz was 120KHz and 1 MHz for above 1 GHz

5.10 Dwell Time

5.10.1 Measurement Procedure:

1. The EUT was placed on a turn table which is 0.8m above ground plane.
2. Set EUT as Normal Operation mode
3. Set SPA Span= 0 Hz, RBW= 10 KHz, VBW= 10 KHz
4. Set SPA Trace 1 Max hold, then View.

5.10.2 Test SET-UP (Block Diagram of Configuration)

The same as described in Section 5.2.2

5.10.3 Measurement Equipment Used:

The same as described in Section 5.2.3

5.10.4 Limits And Measurement Result:

Limits and Measurement Result Of Dwell Time		
Applicable Limits	Measurement Result	
	Test Data	Criteria
Per 15.247 (a)(1)(ii) The average time of occupancy on any frequency shall not be greater than 0.4 seconds	394.76 ms	PASS

Notes:

As the test plots shown below, the Dwell Time(T_d) for each channel is 150.8 ms and the Reap Time(T_r) for each channel is 458.4 ms. So the total Occupation Time(T_o) for each channel during 0.4 s \times total number of the channels (N_c)' observation time is calculated by the following formula:

$$T_o = T_d * (400 * N_c) / T_r = 150.8 * (400 * 3) / 458.4 = 394.76 \text{ ms}$$

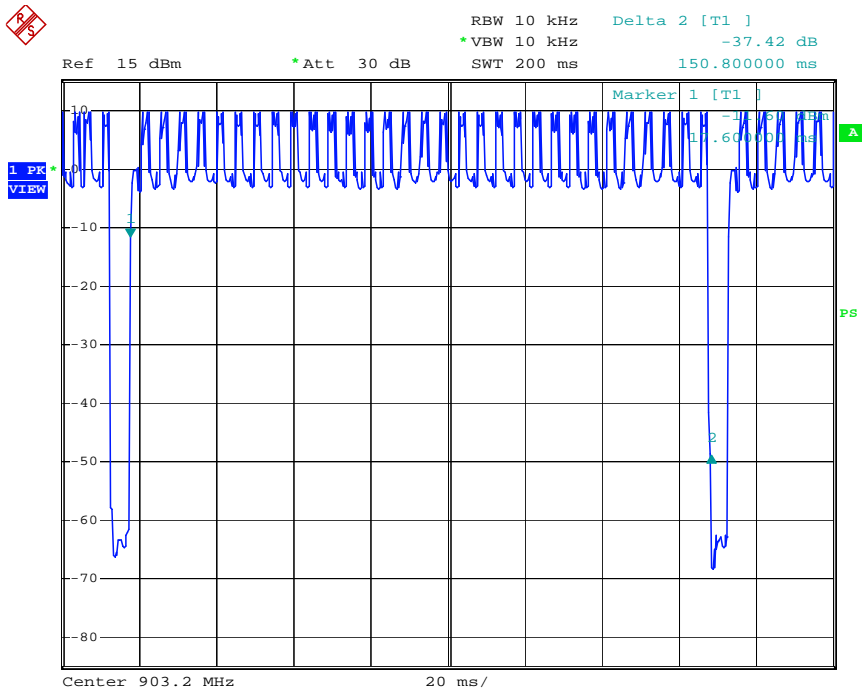

Date: 31.JUL.2006 16:35:47

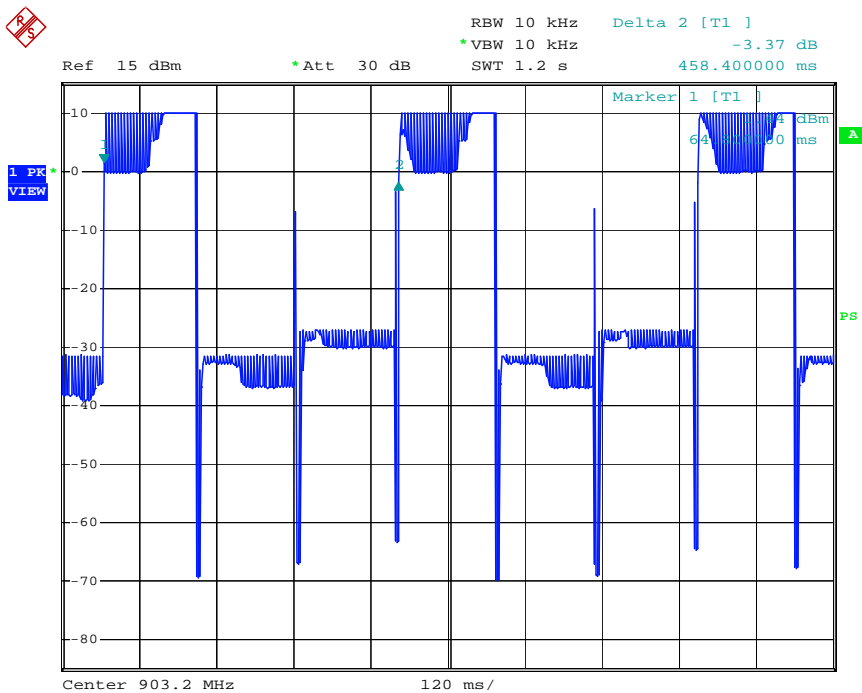

Date: 31.JUL.2006 16:22:45