

Library Security Pedestal 3A -LR Clear User's Guide

Welcome to become a user of Invengo RFID products!

We are very glad that you choose the Library Security Pedestal 3A-LR Clear User's Guide.

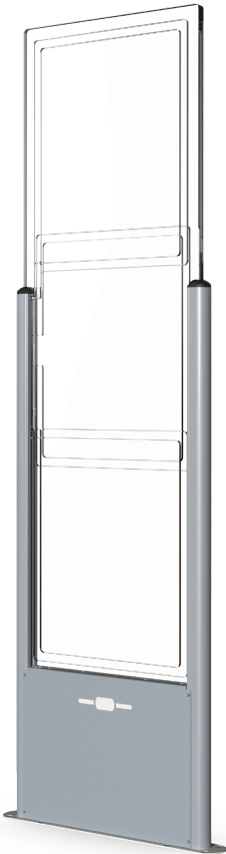

We hope that our equipment can bring convenience to your work.



Foreword

This manual is applicable to the following products:

Library Security Pedestal 3A-LR Clear User's Guide.

 or  **Invengo** logo are owned by Invengo Company.

The introduction and description of product characteristics and functions and other information in this manual are the latest valid information at that time, and all information is accurate at the time of printing. Invengo reserves the right to correct or change the information and instructions in this manual without prior notice and assumes no responsibility for it.

Safety Instructions



Warning sign

Improper operation may do harm to your health.

Improper operation may cause damage to the equipment.



Caution sign

If it is ignored, your operation may not be conducted smoothly.

If it is ignored, it may bring you undesirable results.

Catalogue

1. For Your Safety	8
1.1 General use	8
1.2 Care and maintenance	8
1.3 Important safety information.....	9
2. Certification	10
2.1 Occupational health and safety notices.....	10
2.1.1 Public exposure.....	10
2.1.2 Employees exposure	10
2.2 Safety notices.....	11
2.3 Regulatory notices	11
2.3.1 In europe (CE and RED directives)	12
2.3.2 In USA (FCC Directive)	12
2.4 RoHS and WEEE Directives	14
2.4.1 RoHS.....	14
2.4.2 WEEE	14
3. System Overview	15
3.1 Key features.....	15
3.2 LSP3A-LR Clear brief description.....	16
4. Installation	18
4.1 Recommendations before installation	18
4.1.1 Wire feed sheaths.....	18
4.1.2 Electrical safety rules	19
4.1.3 Network cable installation.....	20

- 4.2 LSP3A RFID system components..... 20
- 4.3 LSP3A-LR Clear 20
 - 4.3.1 Tools required 20
 - 4.3.2 Placement of pedestals..... 21
 - 4.3.3 Installing the pedestal 23
- 4.4 LSP3A-LR Clear replacement or extension of an existing installatio31
- 5. Configuration 32**
 - 5.1 Chip configuration 32
 - 5.1.1 Scanning duration per pedestal 32
 - 5.1.2 Global scanning duration..... 33
 - 5.1.3 EAS mode versus AFI mode 34
 - 5.2 Understanding the LSP3A synchronization process 34
 - 5.2.1 Standard synchronization mode 34
 - 5.2.2 Synchronization by a pair of wires..... 36
 - 5.3 Parameters configuration of the ethernet interface 40
 - 5.4 Configuration of the LSP3A-LR Clear 41
 - 5.5 Running Web UI for the first time 42
 - 5.5.1 Navigation 43
 - 5.5.2 Basic configuration 44
 - 5.5.3 Gate options..... 45
 - 5.5.4 Event of detection..... 57
 - 5.5.5 System configuration 58
 - 5.5.6 Update firmware..... 59
 - 5.6 People counter & buzzer sound m anagement 61
 - 5.6.1 Resetting the counter display 61
 - 5.6.2 Resetting the remote people counter 62

5.6.3 Adjusting the level of the buzzer sound 62

6. Operation 63

6.1 Theory of operation 63

6.2 Starting the system 63

6.3 Normal operation..... 63

6.4 Shutdown 63

7. Maintenance 64

7.1 Servicing the pedestals..... 64

7.2 Electronic and power supply location..... 65

7.3 Servicing the electronics unit 66

8. Troubleshooting..... 67

8.1 Sources of interference 68

9. Technical Specifications..... 69

9.1 Mechanical data LSP3A-LR Clear..... 69

9.2 Electrical data LSP3A-LR Clear model 69

9.3 LSP3A-LR Clear mechanical drawings..... 70

10. Performance Test..... 72

10.1 Test conditions 72

10.2 Test procedure..... 73

LSP3A EAS performance test..... 74

11. Warranty Conditions 75

11.1 Warranty exclusions..... 76

11.2 General provisions..... 77

11.3 How to return defective products 78

Product Return Form 79

01 For Your Safety

Library Security Pedestal 3A-LR Clear User's Guide



1.1 General use

The LSP3A product range is designed to be reliable and to provide continuous, trouble-free service. Please observe the following general tips:

1. Take care not to scratch the device. Keep the device clean. When working with the device, use only INVENGO-approved accessories.
2. This device is not waterproof and should not be exposed to rain or moisture. Under extreme conditions, water may enter the circuitry.
3. Protect the device from extreme temperatures. For example, do not place the device in a windowed area where the sun may cause extreme temperatures, and keep it away from heaters and other heat sources.
4. Do not store or use the device in any location that is extremely dusty, damp, or wet.
5. Use a soft, damp cloth to clean the device. If the surface of the device becomes soiled, clean it with a soft cloth moistened with a diluted window-cleaning solution.

1.2 Care and maintenance

This device should be handled with care. The suggestions below will increase the lifetime of this device.

1. Keep the device dry. Precipitation, humidity and liquids contain minerals that will corrode electronic circuits and tarnish transparent plastic parts.
2. Do not use or store the device in dusty, dirty areas. Its moving parts can be damaged.
3. Regularly dust the large transparent part using a soft cloth and antistatic liquid.

4. Do not store in hot areas. High temperatures can shorten the life of electronic devices, damage batteries and warp or melt certain plastics.
5. Do not store in cold areas. When the device warms up (to its normal temperature), moisture can form inside the device, which may damage electronic circuit boards.
6. Do not attempt to open the device. Non-professional handling of the device may damage it and will void the INVENGO warranty.
7. Handle the device with care. Shock and vibration may break internal circuit boards.
8. Do not paint the device. Paint may clog the device's moving parts and prevent proper operation. Paint with metallic contents may limit device performances.
9. If the device or any accessory are not working properly, take it to your nearest qualified INVENGO representative.

 Do not clean the device, particularly the transparent plastic parts, with harsh chemicals, cleaning solvents or strong detergents. Gently wipe the device with a soft cloth slightly dampened in a mild soap-and-water solution. Eliminate any residual moisture with another clean and wet soft cloth.

Also regularly apply specific antistatic products for Acrylic Surfaces.

1.3 Important safety information

When connecting the device or any accessory to another device, read its user's guide for detailed safety instructions. Do not connect incompatible products.

As with all RF equipment, users are advised that the equipment should only be used in its normal operating mode described in this document.

02 Certification

Library Security Pedestal 3A-LR Clear User's Guide



2.1 Occupational health and safety notices

INVENGO Products have been designed not to exceed the limits given in the European Standard EN 50364 “Limitation of human exposure to electromagnetic fields from devices used in Electronic Article Surveillance (EAS), Radio Frequency Identification (RFID) and similar applications” in conjunction with the European Standard EN 50357 describing how to evaluate the exposure level.

2.1.1 Public exposure

The Library RFID pedestals are designed assuming that patrons cross the detection area within a couple of seconds on their way in and out of the Library at a normal walking pace. General public should not stand in the detection area for more than 10 to 20 seconds.

2.1.2 Employees exposure

The operators are located apart from the principal detection zone and as a matter of fact, not subject to exposure.

(Please see section 4.3.2 “Placement of Pedestals”)

Librarian should make sure that nobody stands still in the Gate Detection Area in between two RFID Pedestals to avoid unnecessary prolonged Exposure to Electromagnetic Field.



2.2 Safety notices

The LSP3A has been tested to be in conformity with the EN standard 60950-1: “Information Technology Equipment Safety”

 For servicing operations it is recommended to deactivate the RFID system.

It is the responsibility of the CII (Certified Integrators by INVENGO) to install the LSP3A as described in INVENGO Product Manuals or INVENGO Documentation. Modification of any INVENGO Library System is prohibited without the written consent of INVENGO. Unauthorized modifications may void the conformity of the equipment to safety specifications and will void the INVENGO warranty.

2.3 Regulatory notices

An RFID system typically composed of an RF emission device such as the XC-RF300 is subject to national regulations that may differ by country.

One important item to consider is the maximum permissible magnetic field intensity at a distance of 10 meters from the antenna that must not exceed 60dB μ A/m in Europe and 38dB μ A/m in US. The LSP3A meets these limits.

2.3.1 In europe (CE and RED directives)

The LSP3A complies (CE Declaration of Conformity granted) with the European EMC directive.

It is the responsibility of the INVENGO Reseller to install the LSP3A as described in this Reference guide or INVENGO Documentation.

Any modification of the LSP3A is prohibited without the written consent of INVENGO. Unauthorized modifications may void the conformity of the equipment to CE and RED Directives and will void the INVENGO warranty.

 It is the responsibility of the CII (Certified Integrators by INVENGO) to install the LSP3A as described in this Reference Guide or in INVENGO Documentation.

 If an LSP3A is further integrated in a different product, it is the responsibility of the manufacturer of this complementary product to obtain the required approvals for this product.

2.3.2 In USA (FCC Directive)

The LSP3A has been designed to comply with Part 15 of the FCC Rules. Furthermore typical configurations listed section 2.2.2 FCC ID Cross Reference Table have been successfully tested with Part 15 of the FCC rules.

WARNING TO USERS IN THE UNITED STATES

FEDERAL COMMUNICATIONS COMMISSION (FCC) RADIO

INTERFERENCE STATEMENT 47 CFR Section 15.105(b)

This equipment has been tested and found to comply with the limits for a Class B digital device, pursuant to Part 15 of the FCC Rules. These limits are designed to provide reasonable protection against harmful interference in a residential installation. This equipment generates, uses and can radiate radio frequency energy and if not installed and used in accordance with the instructions may cause

harmful interference to radio communications. However, there is no guarantee that interference will not occur in a particular installation. If this equipment does cause harmful interference to radio or television reception, which can be determined by turning the equipment off and on, the user is encouraged to try to correct the interference by one or more of the following measures:

- Reorient or relocate the receiving antenna.
- Increase the separation between the equipment and receiver.
- Connect the equipment into an outlet on a circuit different to that to which the receiver is connected.
- Consult the dealer or an experienced radio/TV technician for help.

NO UNAUTHORIZED MODIFICATIONS

47 CFR Section 15.21

CAUTION: This equipment may not be modified, altered, or changed in any way without signed written permission from INVENGO. Unauthorized modification may void the equipment authorization from the FCC and will void the INVENGO warranty.

ANTENNA REQUIREMENT

47 CFR Section 15.203

CAUTION: This equipment must be professionally installed. The installer shall be responsible for ensuring that the proper antenna is employed so that the limits in this part are not exceeded. Nonprofessional installation or installation of the equipment with an improper antenna may void the equipment authorization from the FCC and will void the INVENGO warranty.

2.4 RoHS and WEEE Directives

2.4.1 RoHS

INVENGO certifies that this product is compliant with the European 2011/65/EU & EU 2015/863 for the restriction in Electric and Electronic Equipments (RoHS) of the use of the following hazardous substances:

- a) Lead
- b) Mercury
- c) Cadmium
- d) Hexavalent Chromium
- e) Polybrominated biphenyl flame retardants
- f) Polybrominated diphenyl ether flame retardants

This declaration is based on information provided by our suppliers and subcontractors.

2.4.2 WEEE



This product bears the selective sorting symbol for waste electrical and electronic equipment (WEEE)

This means that this product must be handled pursuant to European Directive 2011/65/EU & EU 2015/863 in order to be recycled or dismantled to minimize its impact on the environment.

For further information, please contact your local or regional authorities.

03 System Overview

Library Security Pedestal 3A-LR Clear User's Guide



3.1 Key features

As a standalone solution, INVENGO security pedestals do not need to be linked to the library database and can still operate when the Integrated Library System (ILS) is down or under maintenance. The security pedestal does not require additional equipment to operate. The LSP3A pedestal features:

- Multi-protocol capabilities, compatible with ISO15693 chips
- Support NXP proprietary EAS mode
- AFI mode with configurable AFI values (up to 4)
- Multi-tag memory reading in AFI Mode (EAS mode for ICODE SLI)
- Read memory data up to 896 bits (28 blocks of 32 bits)
- Embedded system included
- People counter based on dual photoelectric sensors
- Asynchronous event notification over Ethernet

It is a cost effective security system as it only requires a single RFID tag for both anti-theft and identification purposes.

In addition to these standard features, the LSP3A-LR Clear can be personalized upon demand with the library identity printed on plastic covers. The electronic stays the same and performance are unaltered compared to the LSP3A-LR Clear standard model.

3.2 LSP3A-LR Clear brief description

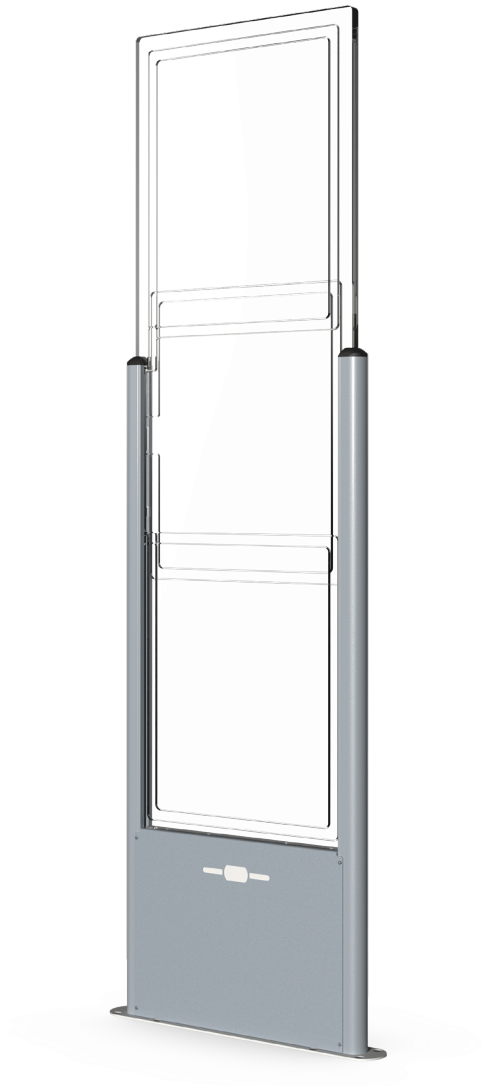

Figure 3.1: LSP3A pedestal

All components of the LSP3A system are contained within the LSP3A. At least two pedestals are required for each EAS gate or passageway. A set of pedestals is known as a gate and may consist of several pedestals. Please see section 4 “Installation” for more information. The LSP3A models are built in a one frame:

- An LSP3A Electronics unit is used to control each pedestal. This electronics unit generates the RF signal transmitted by the antennas and picks up the reply from the RFID tag. If an activated RFID tag is detected, the electronics unit will activate the LED/buzzer alarm
- These antennas are sensitive receivers used to detect the theft bit status and the AFI value of the RFID tag as it passes through the EAS gate
- Visual and audible warning devices
- A remotely accessible people counter equipped with dual light barrier photoelectric sensors.

To operate, the LSP3A-LR Clear Model will only need an IEC power supply cable, avoiding unnecessary mains cable wiring up.

An IEC Mains Supply Cord Outlet is available to allow daisy chaining. A series of up to 5 pedestals can be powered up from a single wall socket.

04 Installation

Library Security Pedestal 3A-LR Clear User's Guide



4.1 Recommendations before installation

This section describes how to install the LSP3A-LR Clear.

4.1.1 Wire feed sheaths

Within the framework installation you need at least a power supply cable sheath and an Ethernet cable sheath to connect to the Ethernet network. These sheathed cables will be located at the bottom center of the pedestal as shown in Figure 4.10. If needed according to the installation configuration, extra sheathed cables need to be placed for wire synchronization, Trigger cable and to remotely switch the RF on & off and I/O cables to drive external devices (Camera, Remote alarms...).

The LSP3A is delivered without any IEC terminated plug power supply cable or Telecommunication cable. It is up to the Local installation personnel to use the appropriate IEC Power Cord according to local electrical regulations.

 Use appropriate IEC power cord according to the local regulations to power up and interconnect the pedestals.

 The Power Supply Cord is the LSP3A Product Main Disconnecting Device, It should be easily accessible at any time to Disconnect the pedestals from the mains power supply.

4.1.2 Electrical safety rules

The LSP3A-LR Clear is powered up via a Mains Supply IEC Cord.

A group of up to 5 Pedestals can be daisy chained and powered via a single IEC power cord connected to a wall socket. The mains wall socket should provide at least 2 Ampere and be protected by a differential circuit breaker limiting the current to 5 Ampere maximum.

Figure 4.1 here below shows how to connect the LSP3A pedestals to the mains.

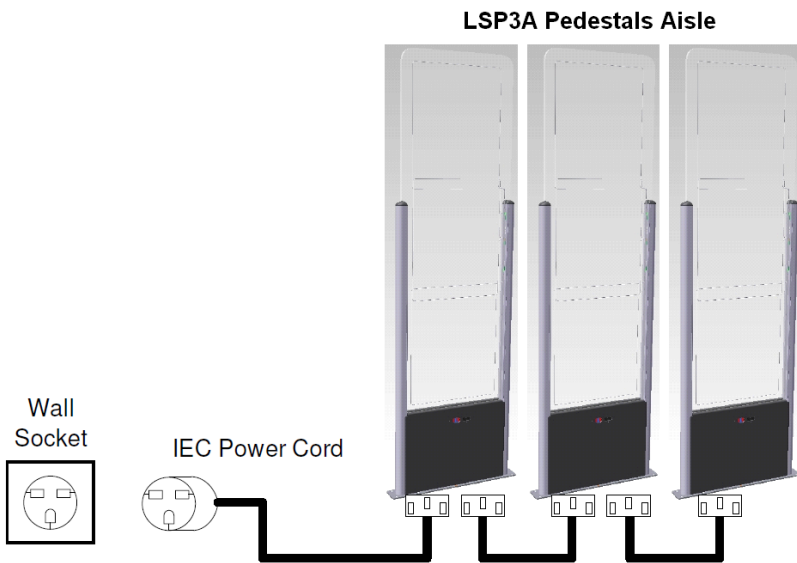

Figure 4.1: Safety Electrical Installation Using Power Cord

! The electrical installation must be carried on by qualified personnel only. For each country where installation takes place, an adequate IEC power supply Cord must be used, fitting the local wall socket layout.

4.1.3 Network cable installation

The LSP3A delivery package does not include an Ethernet cable to connect to a Local Area Network for remote operation. We recommend the use of a Shielded Ethernet cable, UTP-Cat 5.

4.2 LSP3A RFID system components

The components included in the LSP3A RFID System package are listed in Table 4.1

Tble 4.1: LSP3A System Components

Quantity	Description
1	LSP3A Pedestal
1	2 ways 3.81mm Green Screw Tightening Plugs Vertical Cable Entry for Synchronization Cable

4.3 LSP3A-LR Clear

 This equipment is intended for indoor use only under the conditions described in this document. Should it be used outside these conditions cannot be guaranteed, and is not recommended. Please read section 1 “Publishing Information” before installation or use.

4.3.1 Tools required

The following tools are required during installation:

- Measuring Tape
- Square
- Hand Drilling Machine with 4 mm, 8-mm and 19-mm drilling bits
- Philips-head screwdriver
- Spirit Level

4.3.2 Placement of pedestals

Pedestals must be mounted between 800mm and 1600 mm apart (edge to edge) for maximum reliable performance. There should be at least one pair of pedestals at each entrance/exit point of the library. There should be a pedestal at each edge of the entrance, and a Clear space of at least 500 mm around the edge of the pedestals to ensure that the antennas will not be detuned. This Clear space must not contain any metallic objects, but may contain some substrates such as non-metallic/non-conductive building materials such as wood, glass, chipboards and plasterboards.



Each LSP3A should be installed within following tolerances:

Horizontal angular alignment tolerance with reference to pedestals alignment:

$0^{\circ} \pm 2^{\circ}$

Vertical angular tolerance with reference to ground surface : $90^{\circ} \pm 1^{\circ}$



Each LSP3A must be installed at least 2 meters away from sliding doors. Metal frames do pick up & radiate stray Radio ham electromagnetic field which can lead to false triggering. Prior to installation a site survey is highly recommended.

Be cautious to properly align the pedestal in order to center the photoelectric beam sensor on the reflector of the next pedestal.



In case several Pedestal rows (group of Pedestals) to be installed it is mandatory every LSP3A being positioned in the same direction (all people counter of each looking toward the same direction). This would prepare the installation for future implementation of direction sensing.

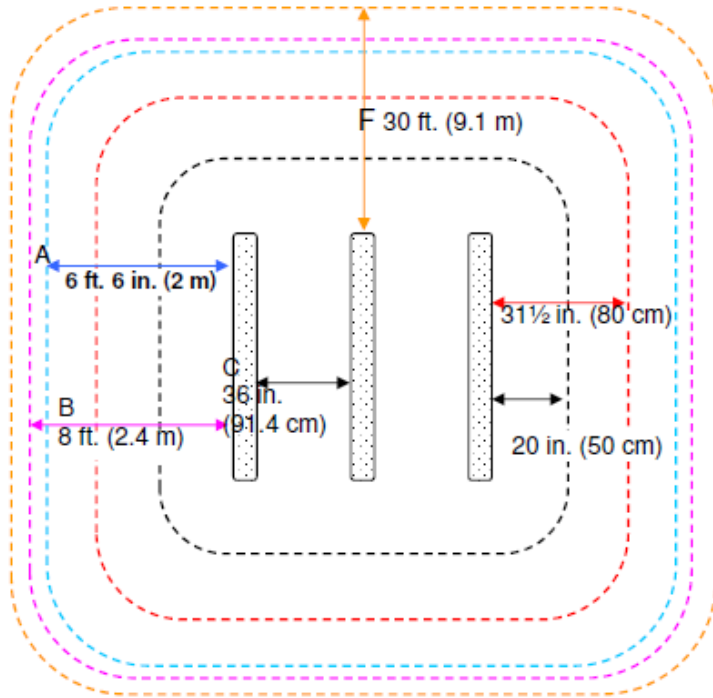

A: Indicates the distance (6 ft. 6in.) to a permanent librarian position.

B: Indicates the distance (8 ft.) from other RFID stations.

C: Indicates the recommended distance (36 in. face panel to face panel) between pedestals.

D: Indicates the minimum distance (31½ in.) between a pedestal and large metal object.

E: Indicates the minimum distance (20 in.) between a pedestal and small metal object.

F: Indicates the minimum distance (30 ft.) between Master pedestals (specific synchronization ID, see section 5.2 “Understanding the LSP3A Synchronization Process”).

Figure 4.2: Clearance Distances around Pedestals

4.3.3 Installing the pedestal

Once the LSP3A will be powered, the photoelectric sensors will emit a red light beam. To precisely align the sensors and the reflector, an orange LED is present on the back of the photoelectric sensor. When the orange LED is continuously on, the sensor and the reflector are perfectly aligned.

To see these LED, one must first unscrew the Plastic Bottom Cover covering the dual cells (see picture of 5.6.1 Resetting the Counter Display).

On the contrary when the orange LED is blinking or off, then you have to adjust the photoelectric sensor, so that the red light beam is centered with the opposite reflector. This operation is achieved using a white paper to clearly see where the red light beam is pointed at. When perfectly centered, the orange LED will continuously be ON.

On Figure 4.6 below, the two Beam Crossing Cells support is shown. To do a fine adjustment of 2 beams, use a hexagonal key to screw or unscrew the top left screw (to adjust height of beams) and the bottom right screw (to adjust the lateral positioning of the beams). They are spring loaded to improve accuracy and keep in place the two sensors after adjustment.

Special attention must be taken for the 2 pedestals positioning:

- They must be positioned facing each other's
- They must be parallel
- They must be well aligned and well centered.
- The orange LED must be continuously ON when powered (See Figure 4.3)
- If the orange LED still blinks when perfectly aligned and centered, check that the spacing does not exceed the recommended values.

- For correct In & Out counter operation, the pedestals must be placed according to the library flow of patrons. See Figure 4.5 and Figure 4.6 for In & Out counting direction.



Figure 4.3: Light Barrier Orange and Green LED Lit when positioning correct
(previous model)

⚠ Before final Installation, do make sure that the Entrance flow is in line with the in Counter Increment Direction Described in Figure 4.5 and Figure 4.6. There is no mean to change the In & Out Counter Direction by software afterward.

Then the 2 pedestals can be secured to the ground.

A good positioning will ensure the two red LED beams to be back scattered by the reflector as shown below. See Figure 4.3 for LED positioning.



Figure 4.4: Light Barrier Latest assembly with 4 LED 7-segment Displays (latest model)

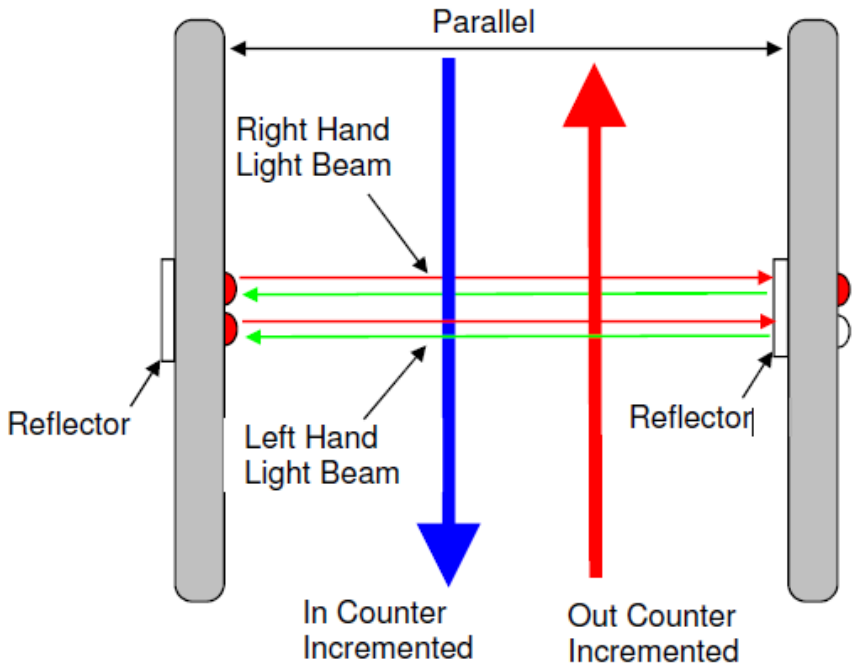

Figure 4.5: Top view of correct LSP3A installation and In/Out Counter Directions

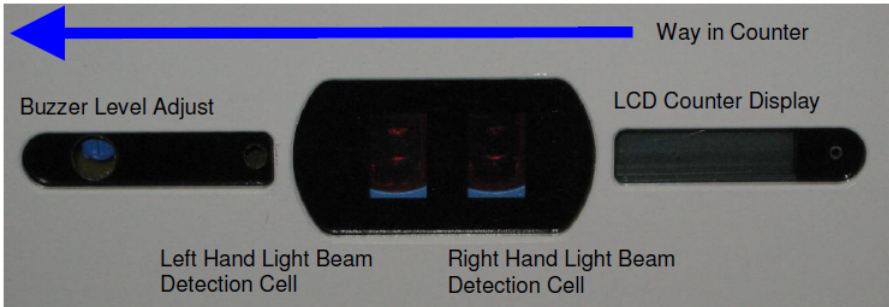

Figure 4.6: People Counter View when facing light barrier and counter display

⚠ Latest People Counters are based on 4-Digit LED Display, Larger and brighter than previous LCD to ease readout. See Figure 4.7: Latest Light beam Crossing Detection Cells & 4 Digits LED Display detailed description and Figure 4.4: Light Barrier Latest assembly with 4 LED 7-segment Displays photograph.

! On LED Displays the maximum Capacity is still of 8 Digits, but the display continuously scrolls above 9999 counts. A decimal point marks the thousands: 11'268 will display the sequence: { 1 } {11.} {11.2} {11.26} {1.268} {,268 } {68 } {8 } { }

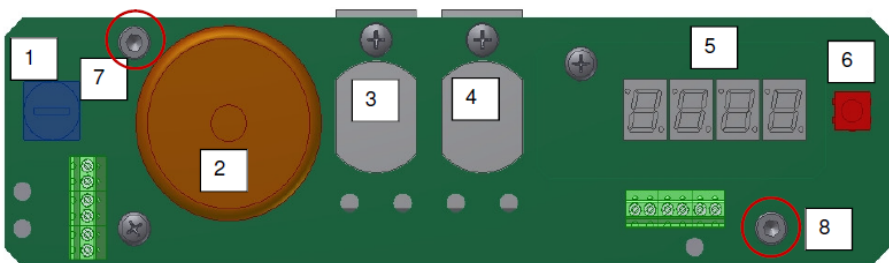

Figure 4.7: Latest Light beam Crossing Detection Cells & 4 Digits LED Display

Table 4.2: Description of Buzzer & Counter board Components

Reference n°	Designation Function
1	Buzzer Volume Adjustment
2	Buzzer
3	Photoelectric Reflex Switch Red Beam
4	Photoelectric Reflex Switch Red Beam
5	LCD or LED Display & Counter
6	Counter Reset Push Button
7	Hexagonal Screw for Light Beam Vertical Alignment
8	Hexagonal Screw for Light Beam Horizontal Alignment

On Figure 4.8 below, the two Beam Crossing Cells support is shown. To do a fine adjustment of the 2 beams, use a hexagonal key to screw or unscrew the top left screw (to adjust height of beams ref 7 circled) and the bottom right screw (to adjust the lateral positioning of the beams ref 8 circled).

They are spring loaded to improve accuracy and keep in place the two sensors after adjustment.

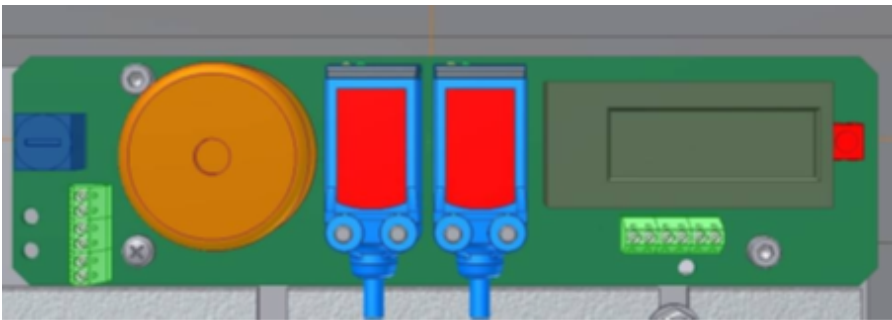

Figure 4.8: Previous Light Beam Crossing Detection Cells & 8 Digit LCD Display

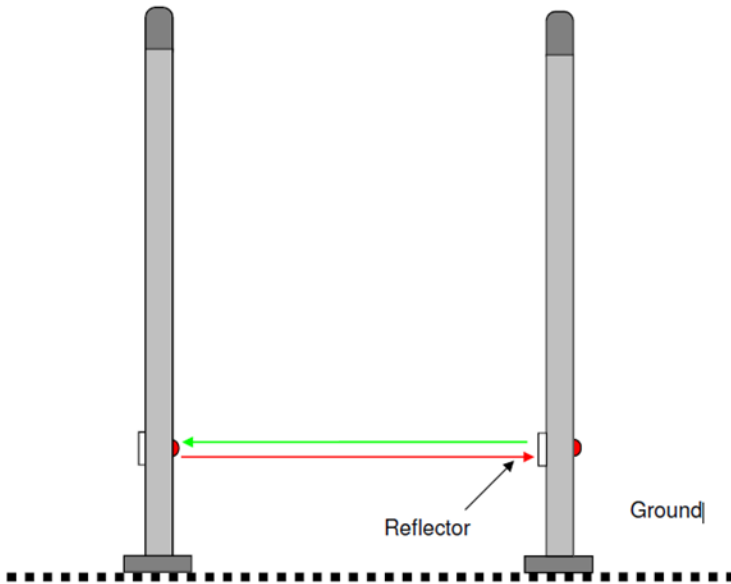

Figure 4.9: Side view of correct LSP3A installation

After having defined the location of the pedestals, refer to the mechanical drawing of the pedestalmounting diagram for the LSP3A-LR Clear (Figure 4.10). The pedestal is fastened to the floor using screws that are strong enough to support the weight of an average adult falling against The pedestal.

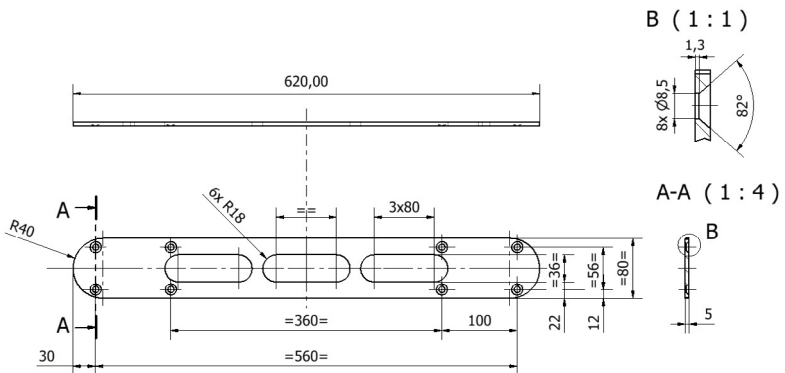

Figure 4.10: LSP3A-LR Clear Mounting Plate Outline

1. Identify and mark the location of the holes to be drilled for mounting the pedestal to the ground. The use of a tape measure and a square is recommended.

2. Drill the cable access and mounting holes according to the type of ground surface:

a. Wooden floor: Drill eight holes with a diameter of 4 mm for the mounting screws and one hole with a diameter of 19 mm for the cable access.

b. Cement floor: Drill eight holes with a diameter of 8 mm for the cement floor plugs and one hole with a diameter of 19 mm for the cable access. It may be necessary to provide a groove for the power supply cable connected to the LSP3A Electronics Unit. Insert the concrete floor plugs into the mounting holes.

⚠ Always use a protective sleeve for main power cable, which match to the flammability grade of the product. Mains power cable must be a 3 wire (line, neutral and earth), multi stranded copper wire, minimum section of $0.75 \text{ mm}^2/3\text{A}$

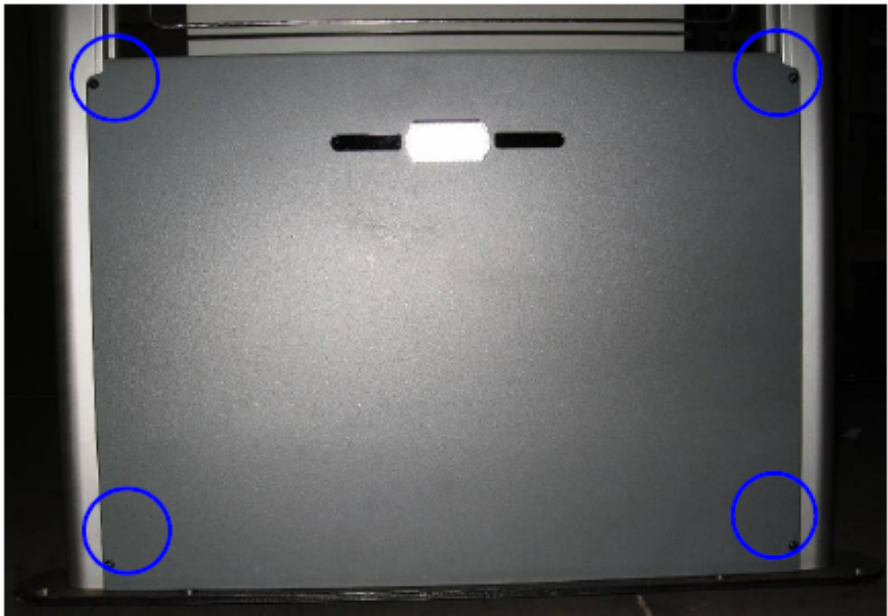

Figure 4.11: LSP3A-LR Clear Bottom Plastic Cover (4 screws)

3. Remove the pedestal from the box.

4. Remove the plastic cover from the both sides after removing the 4 fixing screws.

5. Engage the power supply cable in the electric sheath and the Ethernet cable in the other sheath (please refer to section 4.1.1 “Wire Feed Sheaths”).

6. Place the pedestal base over the mounting holes. Insert and fasten the screws in the mounting holes according to the type of ground surface:

Wooden floor: Insert the screws directly into the mounting holes and tighten the screws in place.

Concrete floor: Insert the screws into the concrete floor plugs and tighten the screws in place.

 When tightening the screws in place, first tighten the screws in place $\frac{3}{4}$ of the way. Once all screws are in place, then tighten each screw progressively, one after each other to ensure that the floor bracket is solidly fixed into place and completely vertically aligned. The use of a level may be required.

7. Plug in the mains IEC power cord from the previous pedestal if daisy chained or from the wall mounted socket. See figure in Chapter Electrical Safety Rules

 No Live AC mains 110/230V during installation! Make sure there is no power supply current before carrying on the connection operations. To do so, unplug the IEC Power Cord from the wall socket.

8. Once all the LSP3A pedestal have been installed, close the micro circuit-breaker (Figure 4.1) to power up the system before starting configuration operations. Please see section 5 “Configuration”.

9. After the configuration has been carried on, replace the two plastic covers and tighten the 4 fixing screws.

4.4 LSP3A-LR Clear replacement or extension of an existing installatio

As all LSP3A-LR Clear have the same mounting plate and people counters location, you can reuse the existing holes drilled into the floor to affix the replacement pedestal and the IEC power cord.

Just make sure that you have the right Radio firmware installed in your new pedestal before starting the system as the aisle synchronization and configuration could be impaired though no irreversible damages would occur.

05 Configuration



All configuration operations of LSP3A systems are carried on with the LSP3A Web UI.

5.1 Chip configuration

For optimal performance the scanning duration (T_{scan}) should not exceed 250ms. T_{scan} is the period to scan all pedestals of a group of N pedestals, i.e. a Master and (N-1) Slave Pedestals. Depending on your chip configuration and the number of pedestals installed you can determine the scanning duration of your installation.

5.1.1 Scanning duration per pedestal

Table 5.1: Scanning Durations No Tag in field

	Duration per pedestal in ETSI mode (ms)	Duration per pedestal in FCC mode (ms)
Synchronization process	10	10
ICODE SLI, ISO15693 EAS or one AFI, detection only	20	100

The scanning duration per pedestal will vary according to the configuration you selected. The scanning duration will always include the synchronization process of 10ms.

Example 1: with a system using the ICODE SLI-AFI in ETSI mode.

The scanning duration per pedestal will be: $T_{single_scan} = (10ms+20ms) = 30ms$

Example 2: with a system using the ICODE SLI-AFI1-AFI2 in ETSI mode.

The scanning duration per pedestal will be: $T_single_scan = (10ms+20ms+20ms) = 50ms$

Example 3: with a system using the ICODE SLI-EAS in ETSI mode.

The scanning duration per pedestal will be: $T_single_scan = (10ms+20ms+15ms) = 45ms$

5.1.2 Global scanning duration

The global scanning duration (T_scan) will depend on the synchronization mode you have selected. Hardwired synchronization is faster than wireless synchronization.

Table 5.2: Global scanning duration versus Synchronisation mode

Synchronization Mode	T_scan
Hardwired	$= T_single_scan \times Nb_Pedestals$

Example 4: with a 4 pedestals system using ICODE SLI-AFI1-AFI2 in ETSI mode.

The global scanning duration will be:

$T_scan = 50ms \times 4 = 200ms$ if used hardwired.

The global scanning duration will be:

$T_scan = 50ms \times ((2 \times 4) - 2) = 300ms$ if used wireless.

5.1.3 EAS mode versus AFI mode

EAS mode is only supported by the ICODE SLI. AFI mode is supported by most ISO15693 chips, from major chip manufacturers (NXP, Texas Instrument, STM, Infineon, MeMarin...).

EAS digital burst is a prime number data stream of 128 bits which is read out after sending a check EAS command to the Tag. This dedicated EAS command is only implemented in NXP SLI chips.

The AFI (Application Family Identifier) is an 8bit-field defined in the ISO15693 standard but not mandatory. Whenever issuing an inventory command with a specific AFI code, only Labels with the same matching AFI code will reply with its UID. Generally the code 9E is used to say that the book has not been properly checked out, thus will be detected by the pedestals.

5.2 Understanding the LSP3A synchronization process

5.2.1 Standard synchronization mode

To manage a group of pedestals, a synchronization burst is sent by the master pedestal to all the slaves' pedestals, a token being propagated back and forth as in a token ring process. This is called the synchronization process.

- Only one pedestal is defined to be the master who emits a synchronization burst to the next slave in close proximity who in turns emits it to the next slave and so forth.
- The other pedestals, configured as slaves, get the synchronization from the neighboring pedestal and emits back to the next Slave of higher index.

 Default Configuration of the LSP3A is set to Master 2 Pedestals.

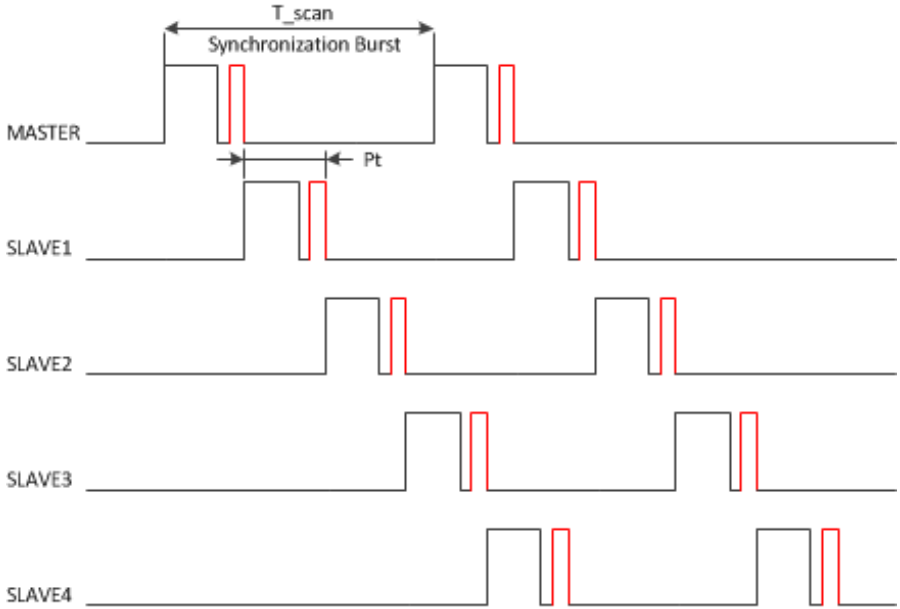

Figure 5.1: Chronogram Sample (1 Master/ 4 Slaves)

- Synchronization burst: start burst to synchronize the gates (Period of T Scan ms)
- Processing time (Pt): depends on the number of tags to be detected and the settings. The fastest is when only detection is used (EAS burst or AFI), the slowest when all features are used (AFI + Read AFI + Read 16 blocks of memory). Refer to the figures in Table 3:Scanning Duration.

Synchronization process for 3 pedestals:

- 1- The master scans the configured chip, then sends the synchronization burst to Slave1
- 2- Slave1 scans the configured chip, then sends the synchronization burst to Slave2
- 3- Slave2 scans the configured chip, and then sends the synchronization burst back to either the master when in hardwire mode.

This process is repeated indefinitely.

In case the master does not receive back the synchronization burst from the last slave after a defined period, it will automatically restart the synchronization process.

The number of pedestals is not limited to any particular number as long as each gate is close enough to its neighboring pedestal and that the overall scanning time does not exceed a few 100ms to allow for a safe detection at 1m/s pace through any gate.

5.2.2 Synchronization by a pair of wires

This mode is mandatory in noisy environments or when nearby RFID devices are placed too near within a couple of meters from any pedestals preventing the installation using wireless settings.

It is also mandatory when using too many pedestals (typically above 4 to 6 pedestals) as wireless burst signal needs to go to the last slave N pedestal and then back going through all N slaves before the master can scan its detection volume again. Processing time is thus equal to $2N$ times P_t in wireless mode.

Using a synchronization cable, the token can be directly handed over by the last slave N to the Master without having to go through all N Slaves pedestals again.

Overall scanning time is thus equal to N times P_t .

In this case the LSP3A synchronization by wire. Refer Figure 5.12 to see the correct fields to be modified. There will always be one & only one LSP3A Master and all others pedestals set as Slaves. Each pedestal is connected to the other using ideally a twisted pair cable. This cable will propagate the synchronization signal to all pedestals in a daisy chain.

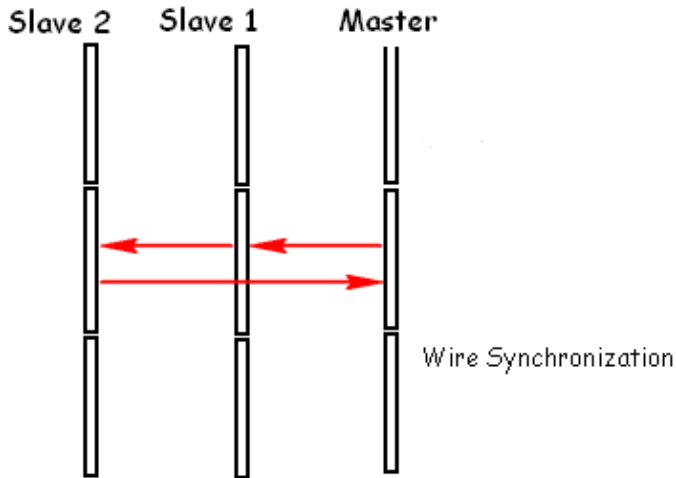

Figure 5.2: 3 Pedestals Configuration Example and Token Propagation Wire Synchronization Token hand over

Wire connection:

First prepare a cable of appropriate length to connect 2 consecutive Electronics as shown in Figure 5.3 and Figure 5.4

A minimum wire gauge of 22AWG (0.2mm²) is enough, preferably a twisted pair. Screw at each extremity of the cable a 2-way connector with ground wire at the same position for each module. If more than 2 pedestals are used to form the aisle, then connect the wires in parallel to go to the next pedestal until you reach the last one.

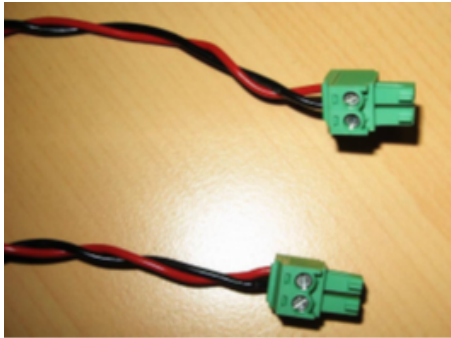

Figure 5.3: Detailed Wire Synchronization Assembly

Then unscrew the 4 screws to open the bottom plastic cover panel of each pedestal forming the aisle to gain access to the Product Electronic Module and connect the top 2-way connector as shown in Figure 5.4 thereafter.

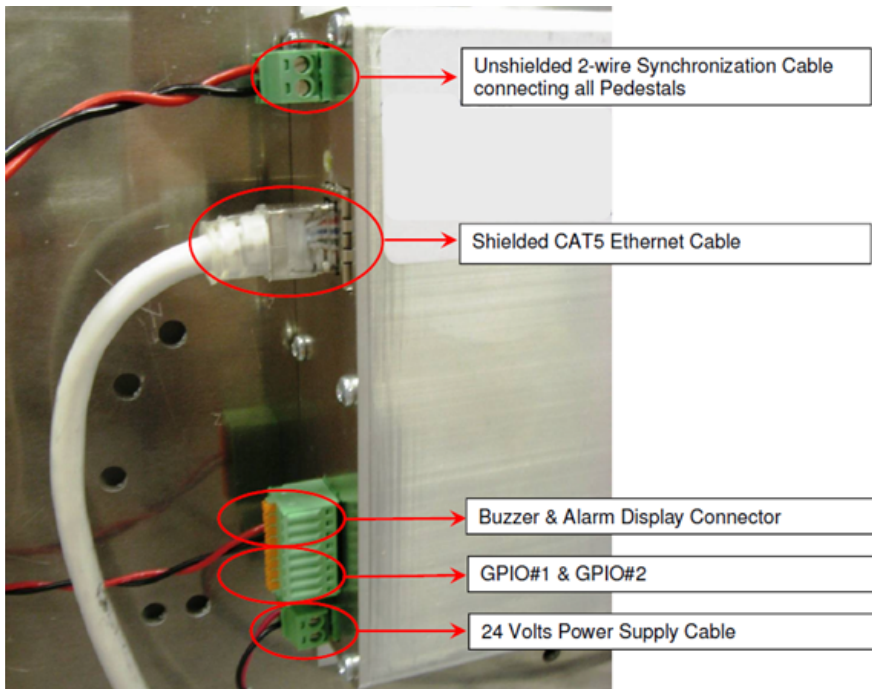

Figure 5.4: LSP3A-LR Clear PEM Connectors & Cables Location

Steps to undergo:

1. Prepare a 2 wire cable of appropriate length and number of connectors to wire up each pedestal. Use the 3.81 mm Push-On Green Plugs Vertical Cable Entry provided.
2. Connect all pedestals Synchronization to the Synchronization I/O as shown on Figure 5.4.
3. Set each pedestal to hardwire synchronization modifying the “Mode” in the “Synch” Section of the “Advanced Configuration” tab of the LSP3A Pedestal Configuration Tool.
4. Write down the MAC address of each pedestal. Use the test button in “Monitoring” tab to locate it: the connected pedestal will ring and its display lit.
5. Power up the whole system (every pedestal must be powered up) and check that the synchronization process works properly detecting a book in each passageway.
6. Put the cover panel back into place and secure it with the 4 screws

5.3 Parameters configuration of the ethernet interface

! Don't forget to power up your installation before carrying on the following steps.

The first step is to allocate a unique IP address to each LSP3A. This operation will allow identifying each LSP3A on site before configuring them on the Ethernet network.

! By default the IP address is 192.168.9.23 (IPv4 Automatic Private IP Addressing). Ask your network administrator to obtain a static IP address for each of the pedestals connected to your local network.

The LSP3A configuration will be carried on using a host computer connected to the local Ethernet network.

! You can localize the each gate thanks to their IP address. Their on site location must be known to configure and set them as Slaves or Master.