

FCC Test Report

Report No.: RF180108C15-3

FCC ID: TOR-W118

Test Model: W-118

Received Date: Jan. 08, 2018

Test Date: Feb. 22 ~ Mar. 12, 2018

Issued Date: Mar. 20, 2018

Applicant: Mojo Networks, Inc.

Address: 339 N. Bernardo Avenue, Suite #200, Mountain View, California United States 94043

Issued By: Bureau Veritas Consumer Products Services (H.K.) Ltd., Taoyuan Branch

Lab Address: No. 47-2, 14th Ling, Chia Pau Vil., Lin Kou Dist., New Taipei City, Taiwan (R.O.C.)

Test Location: No. 19, Hwa Ya 2nd Rd., Wen Hwa Vil., Kwei Shan Dist., Taoyuan City 33383, TAIWAN (R.O.C.)

FCC Registration / Designation Number: 788550 / TW0003



This report is for your exclusive use. Any copying or replication of this report to or for any other person or entity, or use of our name or trademark, is permitted only with our prior written permission. This report sets forth our findings solely with respect to the test samples identified herein. The results set forth in this report are not indicative or representative of the quality or characteristics of the lot from which a test sample was taken or any similar or identical product unless specifically and expressly noted. Our report includes all of the tests requested by you and the results thereof based upon the information that you provided to us. You have 60 days from date of issuance of this report to notify us of any material error or omission caused by our negligence, provided, however, that such notice shall be in writing and shall specifically address the issue you wish to raise. A failure to raise such issue within the prescribed time shall constitute your unqualified acceptance of the completeness of this report, the tests conducted and the correctness of the report contents. Unless specific mention, the uncertainty of measurement has been explicitly taken into account to declare the compliance or non-compliance to the specification. The report must not be used by the client to claim product certification, approval, or endorsement by TAF or any government agencies.

Table of Contents

Release Control Record	4
1 Certificate of Conformity	5
2 Summary of Test Results	6
2.1 Measurement Uncertainty.....	6
2.2 Modification Record.....	6
3 General Information	7
3.1 General Description of EUT.....	7
3.2 Description of Test Modes.....	9
3.2.1 Test Mode Applicability and Tested Channel Detail.....	10
3.3 Duty Cycle of Test Signal.....	12
3.4 Description of Support Units.....	14
3.4.1 Configuration of System under Test.....	14
3.5 General Description of Applied Standards.....	15
4 Test Types and Results	16
4.1 Radiated Emission and Bandedge Measurement.....	16
4.1.1 Limits of Radiated Emission and Bandedge Measurement.....	16
4.1.2 Test Instruments.....	17
4.1.3 Test Procedures.....	18
4.1.4 Deviation from Test Standard.....	18
4.1.5 Test Setup.....	19
4.1.6 EUT Operating Conditions.....	20
4.1.7 Test Results.....	21
4.2 Conducted Emission Measurement.....	61
4.2.1 Limits of Conducted Emission Measurement.....	61
4.2.2 Test Instruments.....	61
4.2.3 Test Procedures.....	62
4.2.4 Deviation from Test Standard.....	62
4.2.5 Test Setup.....	62
4.2.6 EUT Operating Conditions.....	62
4.2.7 Test Results.....	63
4.3 Transmit Power Measurement.....	71
4.3.1 Limits of Transmit Power Measurement.....	71
4.3.2 Test Setup.....	71
4.3.3 Test Instruments.....	71
4.3.4 Test Procedure.....	72
4.3.5 Deviation from Test Standard.....	72
4.3.6 EUT Operating Conditions.....	72
4.3.7 Test Result.....	73
4.4 Occupied Bandwidth Measurement.....	76
4.4.1 Test Setup.....	76
4.4.2 Test Instruments.....	76
4.4.3 Test Procedure.....	76
4.4.4 Test Result.....	77
4.5 Peak Power Spectral Density Measurement.....	81
4.5.1 Limits of Peak Power Spectral Density Measurement.....	81
4.5.2 Test Setup.....	81
4.5.3 Test Instruments.....	81
4.5.4 Test Procedures.....	81
4.5.5 Deviation from Test Standard.....	82
4.5.6 EUT Operating Conditions.....	82
4.5.7 Test Results.....	83
4.6 Frequency Stability.....	93
4.6.1 Limits of Frequency Stability Measurement.....	93

4.6.2	Test Setup.....	93
4.6.3	Test Instruments	93
4.6.4	Test Procedure	93
4.6.5	Deviation from Test Standard	93
4.6.6	EUT Operating Condition	93
4.6.7	Test Results	94
4.7	6dB Bandwidth Measurement.....	96
4.7.1	Limits of 6dB Bandwidth Measurement.....	96
4.7.2	Test Setup.....	96
4.7.3	Test Instruments	96
4.7.4	Test Procedure	96
4.7.5	Deviation from Test Standard	96
4.7.6	EUT Operating Condition	96
4.7.7	Test Results	97
5	Pictures of Test Arrangements.....	101
	Annex A- Radiated Out of Band Emission (OOBE) Measurement (For U-NII-3 band).....	102
	Appendix – Information on the Testing Laboratories	108

Release Control Record

Issue No.	Description	Date Issued
RF180108C15-3	Original release.	Mar. 20, 2018

1 Certificate of Conformity

Product: Wall Jack Access Point

Brand: Mojo

Test Model: W-118

Sample Status: Engineering sample

Applicant: Mojo Networks, Inc.

Test Date: Feb. 22 ~ Mar. 12, 2018

Standards: 47 CFR FCC Part 15, Subpart E (Section 15.407)
ANSI C63.10:2013

The above equipment has been tested by **Bureau Veritas Consumer Products Services (H.K.) Ltd., Taoyuan Branch**, and found compliance with the requirement of the above standards. The test record, data evaluation & Equipment Under Test (EUT) configurations represented herein are true and accurate accounts of the measurements of the sample's RF characteristics under the conditions specified in this report.

Prepared by :  , **Date:** Mar. 20, 2018
Pettie Chen / Senior Specialist

Approved by :  , **Date:** Mar. 20, 2018
Bruce Chen / Project Engineer

2 Summary of Test Results

47 CFR FCC Part 15, Subpart E (Section 15.407)			
FCC Clause	Test Item	Result	Remarks
15.407(b)(6)	AC Power Conducted Emissions	Pass	Meet the requirement of limit. Minimum passing margin is -5.18dB at 0.16172MHz.
15.407(b)(1/2/3/4(i/ii)/6)	Radiated Emissions & Band Edge Measurement	Pass	Meet the requirement of limit. Minimum passing margin is -1.0dB at 5150.00, 11650.00MHz.
15.407(a)(1/2/3)	Max Average Transmit Power	Pass	Meet the requirement of limit.
---	Occupied Bandwidth Measurement	-	Reference only.
15.407(a)(1/2/3)	Peak Power Spectral Density	Pass	Meet the requirement of limit.
15.407(e)	6dB bandwidth	Pass	Meet the requirement of limit. (U-NII-3 Band only)
15.407(g)	Frequency Stability	Pass	Meet the requirement of limit.
15.203	Antenna Requirement	Pass	Antenna connector is IPEX not a standard connector.

*For U-NII-3 band compliance with rule part 15.407(b)(4)(i), the OOB test plots were recorded in Annex A.

2.1 Measurement Uncertainty

Where relevant, the following measurement uncertainty levels have been estimated for tests performed on the EUT as specified in CISPR 16-4-2:

Measurement	Frequency	Expanded Uncertainty (k=2) (\pm)
Conducted Emissions at mains ports	150kHz ~ 30MHz	2.94 dB
Radiated Emissions up to 1 GHz	30MHz ~ 200MHz	3.86 dB
	200MHz ~ 1000MHz	3.87 dB
Radiated Emissions above 1 GHz	1GHz ~ 18GHz	2.29 dB
	18GHz ~ 40GHz	2.29 dB

2.2 Modification Record

There were no modifications required for compliance.

3 General Information

3.1 General Description of EUT

Product	Wall Jack Access Point
Brand	Mojo
Test Model	W-118
Sample Status	Engineering sample
Power Supply Rating	12Vdc from Adapter 54Vdc from POE
Modulation Type	256QAM, 64QAM, 16QAM, QPSK, BPSK
Modulation Technology	OFDM
Transfer Rate	802.11a: 54/48/36/24/18/12/9/6Mbps 802.11n: up to 300Mbps 802.11ac: up to 867Mbps
Operating Frequency	5180~5240MHz, 5745~5825MHz
Number of Channel	5180~5240MHz: 802.11a, 802.11n (HT20), 802.11ac (VHT20): 4 802.11n (HT40), 802.11ac (VHT40): 2 802.11ac (VHT80): 1 5745~5825MHz: 802.11a, 802.11n (HT20), 802.11ac (VHT20): 5 802.11n (HT40), 802.11ac (VHT40): 2 802.11ac (VHT80): 1
Output Power	Radio 2: CDD Mode: 5180 ~ 5240MHz: 277.997mW 5745 ~ 5825MHz: 460.176mW Beamforming Mode: 5180 ~ 5240MHz: 139.008mW 5745 ~ 5825MHz: 230.104mW Radio 3: CDD Mode: 5180 ~ 5240MHz: 53.633mW 5745 ~ 5825MHz: 51.192mW
Antenna Type	Refer to note
Antenna Connector	Refer to note
Accessory Device	NA
Cable Supplied	NA

Note:

1. The EUT incorporates a MIMO function. Physically, the EUT provides 2 completed transmitters and 2 receivers.

Modulation Mode	TX Function	Beamforming Mode	Remark
802.11a	2TX	Not Support	Radio 2 (Master)
802.11n (HT20)	2TX	Support	
802.11n (HT40)	2TX	Support	
802.11ac (VHT20)	2TX	Support	
802.11ac (VHT40)	2TX	Support	
802.11ac (VHT80)	2TX	Support	
802.11a	2TX	Not Support	Radio 3 (Client)
802.11n (HT20)	2TX	Not Support	
802.11n (HT40)	2TX	Not Support	
802.11ac (VHT20)	2TX	Not Support	
802.11ac (VHT40)	2TX	Not Support	
802.11ac (VHT80)	2TX	Not Support	

* The modulation and bandwidth are similar for 802.11n mode for 20MHz/40MHz and 802.11ac mode for 20MHz/40MHz, therefore investigated worst case to representative mode in test report. (Final test mode refer section 3.2.1)

* For 802.11n and 802.11ac, CDD mode and Beamforming mode are presented in power output test item. For other test items, CDD mode is the worst case for final tests after pretesting.

2. The EUT consumes power from following Adapter and POE. (Support unit only)

Adapter	
Brand	Powertron Electronics Corp.
Model	PA1024-120IB200
Input Power	100-240Vac, 50-60Hz, 0.6A
Output Power	12Vdc / 2.0A 24W Max
Power Cord	1.5m non-shielded cable with one core 0.5m non-shielded cable without core

POE	
Brand	EnGenius
Model	EPA5006GAT
Input Power	100-240Vac, 50-60Hz, 0.8A
Output Power	54Vdc, 0.6A

3. The EUT uses following antennas.

Type	PIFA						PIFA
Connector	IPEX						-
Radio	1		2		3		BT/Zigbee
Frequency (MHz)	2400-2500		5150-5850		2400-2500 & 5150-5850		2400-2500
Antenna	1	2	3	4	5	6	BT/Zigbee
Gain (dBi)	3.67	4.31	5.72	5.99	2.51 / 4.83	2.78 / 4.80	2.76

4. Spurious emission of the simultaneous operation mode as below and the test data please refer to report no.: RF180108C15-4.

No	Mode
1	Radio 1 + Radio 2 + Radio 3(2.4GHz) + BT LE
2	Radio 1 + Radio 3(5GHz) + BT LE
3	Radio 1 + Radio 2 + Radio 3(2.4GHz)+ Zigbee
4	Radio 1 + Radio 3(5GHz) + Zigbee

*The Radio 2 and Radio 3(5GHz) cannot transmit simultaneously.

3.2 Description of Test Modes

5180~5240MHz:

4 channels are provided for 802.11a, 802.11n (HT20), 802.11ac (VHT20):

Channel	Frequency	Channel	Frequency
36	5180 MHz	44	5220 MHz
40	5200 MHz	48	5240 MHz

2 channels are provided for 802.11n (HT40), 802.11ac (VHT40):

Channel	Frequency	Channel	Frequency
38	5190 MHz	46	5230 MHz

1 channel is provided for 802.11ac (VHT80):

Channel	Frequency
42	5210MHz

5745~5825MHz:

5 channels are provided for 802.11a, 802.11n (HT20), 802.11ac (VHT20):

Channel	Frequency	Channel	Frequency
149	5745MHz	161	5805MHz
153	5765MHz	165	5825MHz
157	5785MHz		

2 channels are provided for 802.11n (HT40), 802.11ac (VHT40):

Channel	Frequency	Channel	Frequency
151	5755MHz	159	5795MHz

1 channel is provided for 802.11ac (VHT80):

Channel	Frequency
155	5775MHz

3.2.1 Test Mode Applicability and Tested Channel Detail

EUT Configure Mode	Applicable to				Description	
	RE \geq 1G	RE $<$ 1G	PLC	APCM	Radio	Power
A	√	√	√	√	Radio 2	Power from adapter
B	-	√	√	-		Power from PoE
C	√	√	√	√	Radio 3	Power from adapter
D	-	√	√	-		Power from PoE

Where RE \geq 1G: Radiated Emission above 1GHz & Bandedge Measurement
 RE $<$ 1G: Radiated Emission below 1GHz
 PLC: Power Line Conducted Emission
 APCM: Antenna Port Conducted Measurement

Note:

- The EUT had been pre-tested on the positioned of each 3 axis. The worst case was found when positioned on **Y-plane (For Test Mode A, B), Z-plane (For Test Mode C, D)**.
- "-" means no effect.

Radiated Emission Test (Above 1GHz):

- Pre-Scan has been conducted to determine the worst-case mode from all possible combinations between available modulations, data rates and antenna ports (if EUT with antenna diversity architecture).
- Following channel(s) was (were) selected for the final test as listed below.

EUT Configure Mode	Mode	Frequency Band (MHz)	Available Channel	Tested Channel	Modulation Technology	Data Rate (Mbps)
A, C	802.11a	5180-5240	36 to 48	36, 40, 48	OFDM	6.0
	802.11n (HT20)		36 to 48	36, 40, 48	OFDM	6.5
	802.11n (HT40)		38 to 46	38, 46	OFDM	13.5
	802.11ac (VHT80)		42	42	OFDM	58.5
A, C	802.11a	5745-5825	149 to 165	149, 157, 165	OFDM	6.0
	802.11n (HT20)		149 to 165	149, 157, 165	OFDM	6.5
	802.11n (HT40)		151 to 159	151, 159	OFDM	13.5
	802.11ac (VHT80)		155	155	OFDM	58.5

Radiated Emission Test (Below 1GHz):

- Pre-Scan has been conducted to determine the worst-case mode from all possible combinations between available modulations, data rates and antenna ports (if EUT with antenna diversity architecture).
- Following channel(s) was (were) selected for the final test as listed below.

EUT Configure Mode	Mode	Frequency Band (MHz)	Available Channel	Tested Channel	Modulation Technology	Data Rate (Mbps)
A, B, C, D	802.11a	5180-5240	36 to 48	165	OFDM	6.0
	802.11a	5745-5825	149 to 165		OFDM	6.0

Power Line Conducted Emission Test:

- Pre-Scan has been conducted to determine the worst-case mode from all possible combinations between available modulations, data rates and antenna ports (if EUT with antenna diversity architecture).
- Following channel(s) was (were) selected for the final test as listed below.

EUT Configure Mode	Mode	Frequency Band (MHz)	Available Channel	Tested Channel	Modulation Technology	Data Rate (Mbps)
A, B, C, D	802.11a	5180-5240	36 to 48	165	OFDM	6.0
	802.11a	5745-5825	149 to 165		OFDM	6.0

Transmit Power Measurement:

- This item includes all test value of each mode, but only includes spectrum plot of worst value of each mode.
- Pre-Scan has been conducted to determine the worst-case mode from all possible combinations between available modulations, data rates and antenna ports (if EUT with antenna diversity architecture).
- Following channel(s) was (were) selected for the final test as listed below.

EUT Configure Mode	Mode	Frequency Band (MHz)	Available Channel	Tested Channel	Modulation Technology	Data Rate (Mbps)
A, C	802.11a	5180-5240	36 to 48	36, 40, 48	OFDM	6.0
	802.11n (HT20)		36 to 48	36, 40, 48	OFDM	6.5
	802.11n (HT40)		38 to 46	38, 46	OFDM	13.5
	802.11ac (VHT80)		42	42	OFDM	58.5
A, C	802.11a	5745-5825	149 to 165	149, 157, 165	OFDM	6.0
	802.11n (HT20)		149 to 165	149, 157, 165	OFDM	6.5
	802.11n (HT40)		151 to 159	151, 159	OFDM	13.5
	802.11ac (VHT80)		155	155	OFDM	58.5

Peak Power Spectral Density, Bandwidth and Frequency Stability Measurement:

- This item includes all test value of each mode, but only includes spectrum plot of worst value of each mode.
- Pre-Scan has been conducted to determine the worst-case mode from all possible combinations between available modulations, data rates and antenna ports (if EUT with antenna diversity architecture).
- Following channel(s) was (were) selected for the final test as listed below.

EUT Configure Mode	Mode	Frequency Band (MHz)	Available Channel	Tested Channel	Modulation Technology	Data Rate (Mbps)
A, C	802.11a	5180-5240	36 to 48	36, 40, 48	OFDM	6.0
	802.11n (HT20)		36 to 48	36, 40, 48	OFDM	6.5
	802.11n (HT40)		38 to 46	38, 46	OFDM	13.5
	802.11ac (VHT80)		42	42	OFDM	58.5
A, C	802.11a	5745-5825	149 to 165	149, 157, 165	OFDM	6.0
	802.11n (HT20)		149 to 165	149, 157, 165	OFDM	6.5
	802.11n (HT40)		151 to 159	151, 159	OFDM	13.5
	802.11ac (VHT80)		155	155	OFDM	58.5

Test Condition:

Applicable to	Environmental Conditions	Input Power	Tested by
RE \geq 1G	21 deg. C, 68% RH 20 deg. C, 68% RH 22 deg. C, 68% RH	120Vac, 60Hz	Willy Cheng, Adair Peng Jones Chang
RE<1G	22 deg. C, 68% RH	120Vac, 60Hz	Adair Peng
PLC	25 deg. C, 75% RH	120Vac, 60Hz	Noah Chang
APCM	25 deg. C, 60% RH	120Vac, 60Hz	Chris Lin

3.3 Duty Cycle of Test Signal

Test Mode A

Duty cycle of test signal is < 98%, duty factor is required.

802.11a: Duty cycle = 2.06/2.14 = 0.963, Duty factor = 10 * log(1/0.963) = 0.17

802.11n (HT20): Duty cycle = 4.991/5.106 = 0.977, Duty factor = 10 * log(1/0.977) = 0.10

802.11n (HT40): Duty cycle = 2.421/2.507 = 0.966, Duty factor = 10 * log(1/0.966) = 0.15

802.11ac (VHT80): Duty cycle = 1.14/1.237 = 0.922, Duty factor = 10 * log(1/0.922) = 0.35

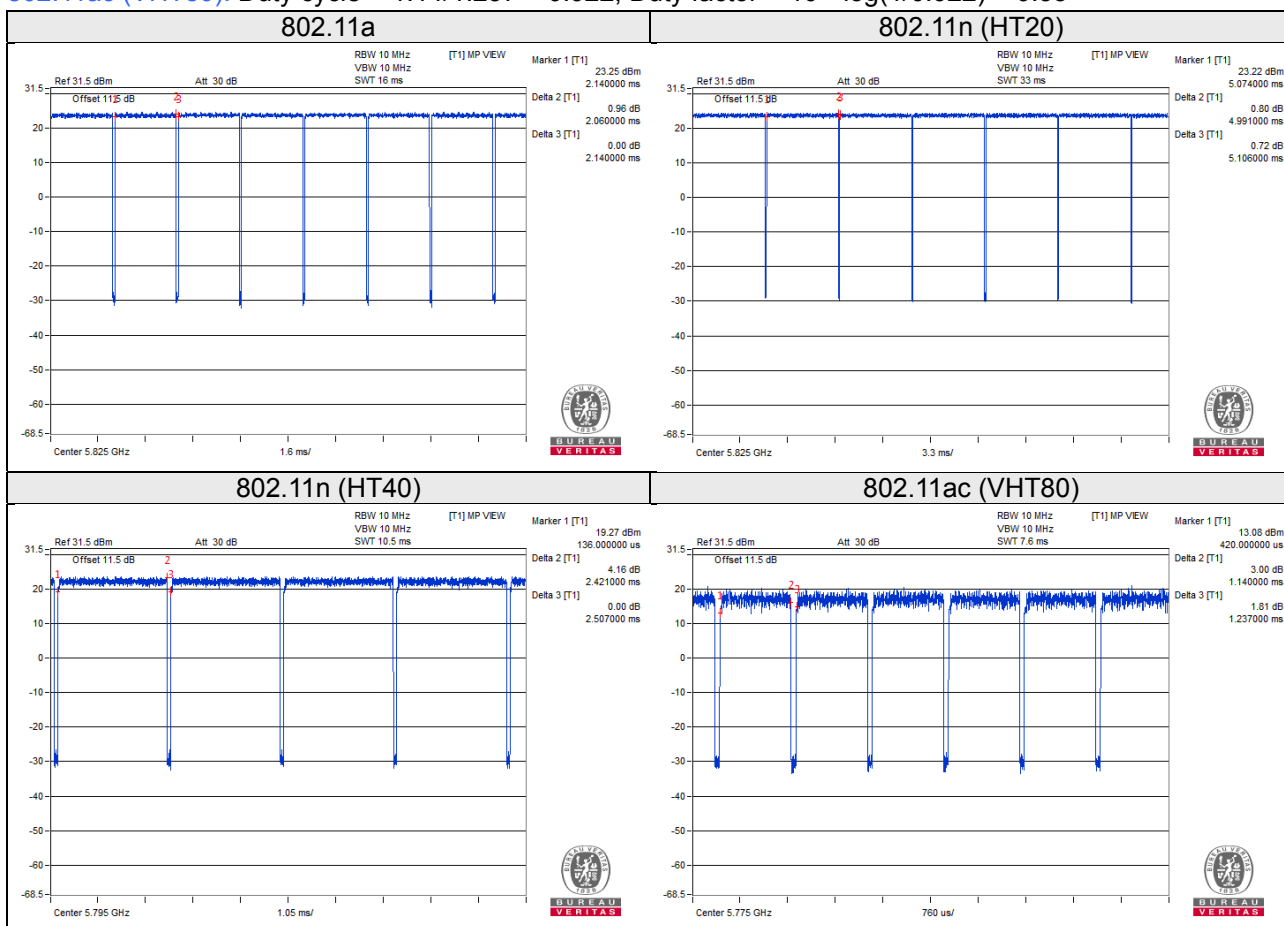

Test Mode C

Duty cycle of test signal is < 98%, duty factor is required.

802.11a: Duty cycle = $2.051/2.160 = 0.950$, Duty factor = $10 * \log(1/0.950) = 0.22$

802.11n (HT20): Duty cycle = $1.917/2.016 = 0.951$, Duty factor = $10 * \log(1/0.951) = 0.22$

802.11n (HT40): Duty cycle = $0.942/1.010 = 0.933$, Duty factor = $10 * \log(1/0.933) = 0.30$

802.11ac (VHT80): Duty cycle = $0.463/0.545 = 0.850$, Duty factor = $10 * \log(1/0.850) = 0.71$

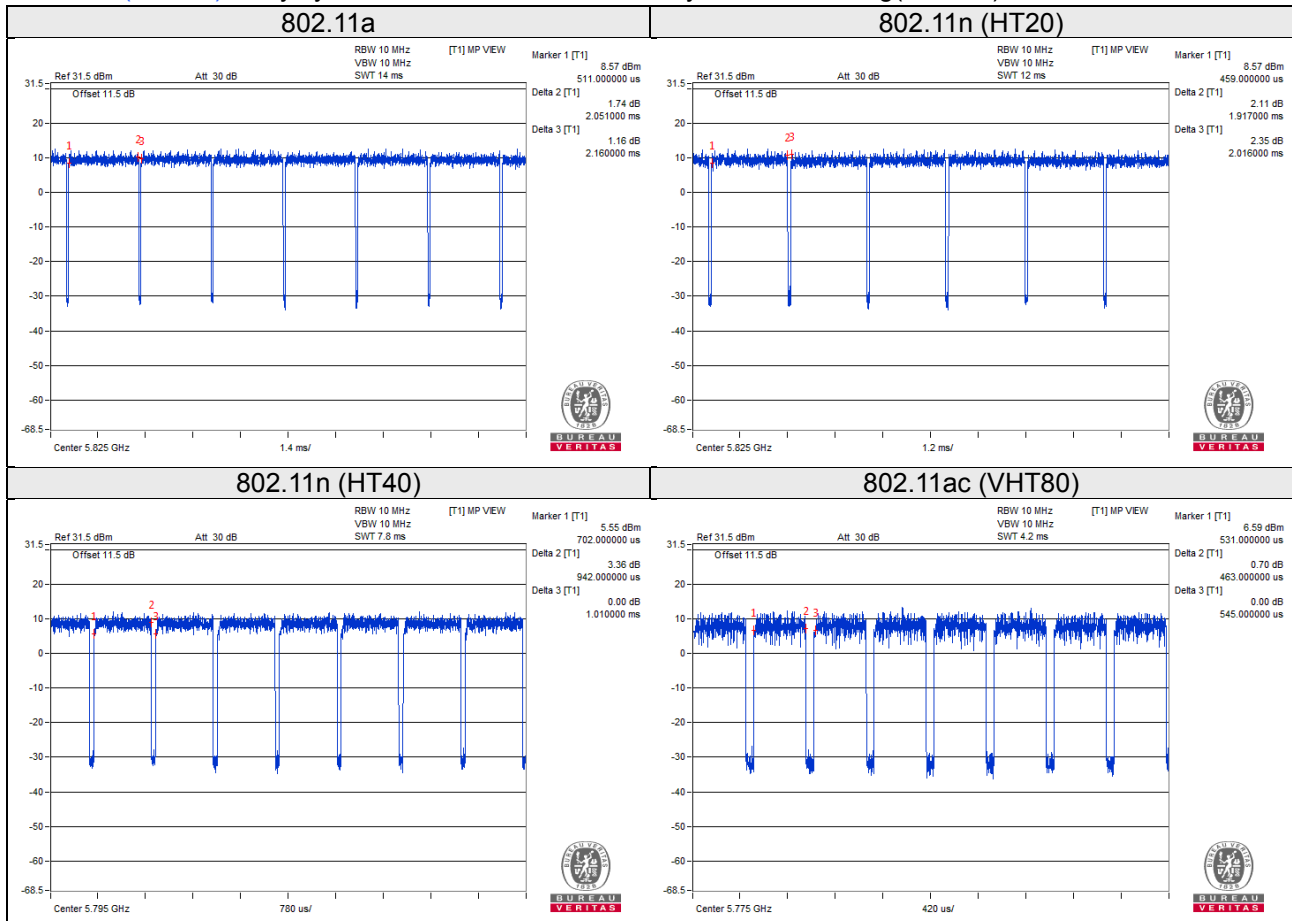

3.4 Description of Support Units

The EUT has been tested as an independent unit together with other necessary accessories or support units. The following support units or accessories were used to form a representative test configuration during the tests.

ID	Product	Brand	Model No.	Serial No.	FCC ID	Remarks
A.	Notebook	Lenovo	80Q7	PF0KUGU6	FCC DoC Approved	-
B.	Adapter	Powertron	PA1024-120IB200	NA	NA	Provided by manufacturer
C.	Load	NA	NA	NA	NA	-
D.	POE	EnGenius	EPA5006GAT	NA	NA	Provided by manufacturer

Note:

1. All power cords of the above support units are non-shielded (1.8m).
2. Item A acted as a communication partner to transfer data.

ID	Descriptions	Qty.	Length (m)	Shielding (Yes/No)	Cores (Qty.)	Remarks
1.	RJ45, Cat5e	1	10	N	0	-
2.	RJ45, Cat5e	4	3	N	0	-
3.	Power Cord	1	1.0	N	0	-
4.	RJ45, Cat5e	1	3	N	0	-

Note: The core(s) is(are) originally attached to the cable(s).

3.4.1 Configuration of System under Test

Test Mode A, C

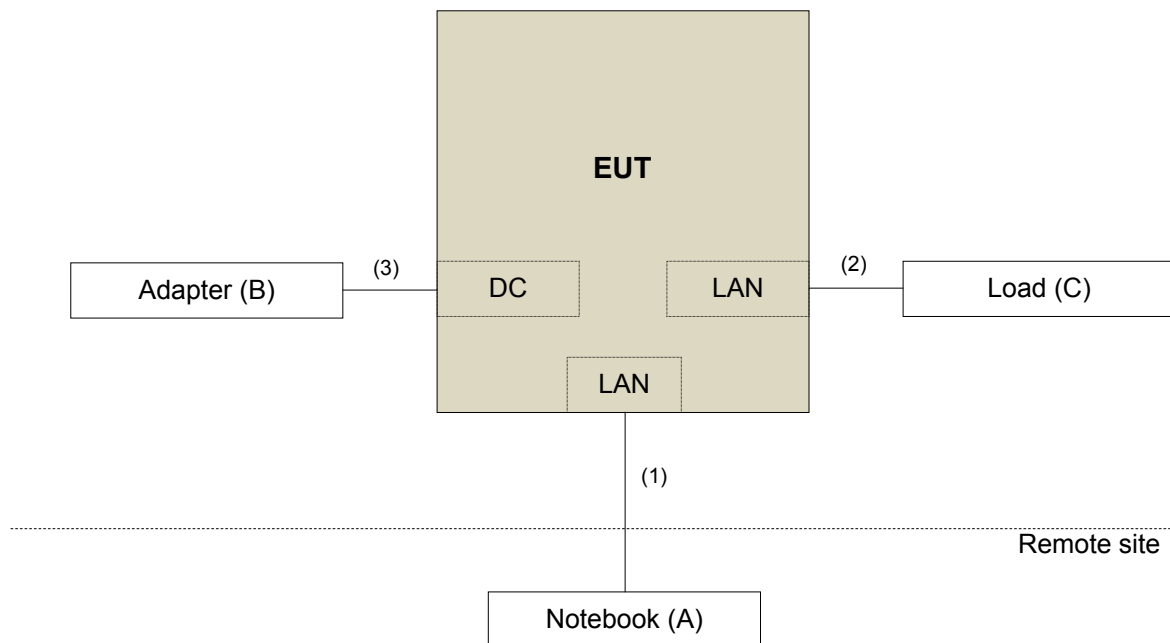

Test Mode B, D

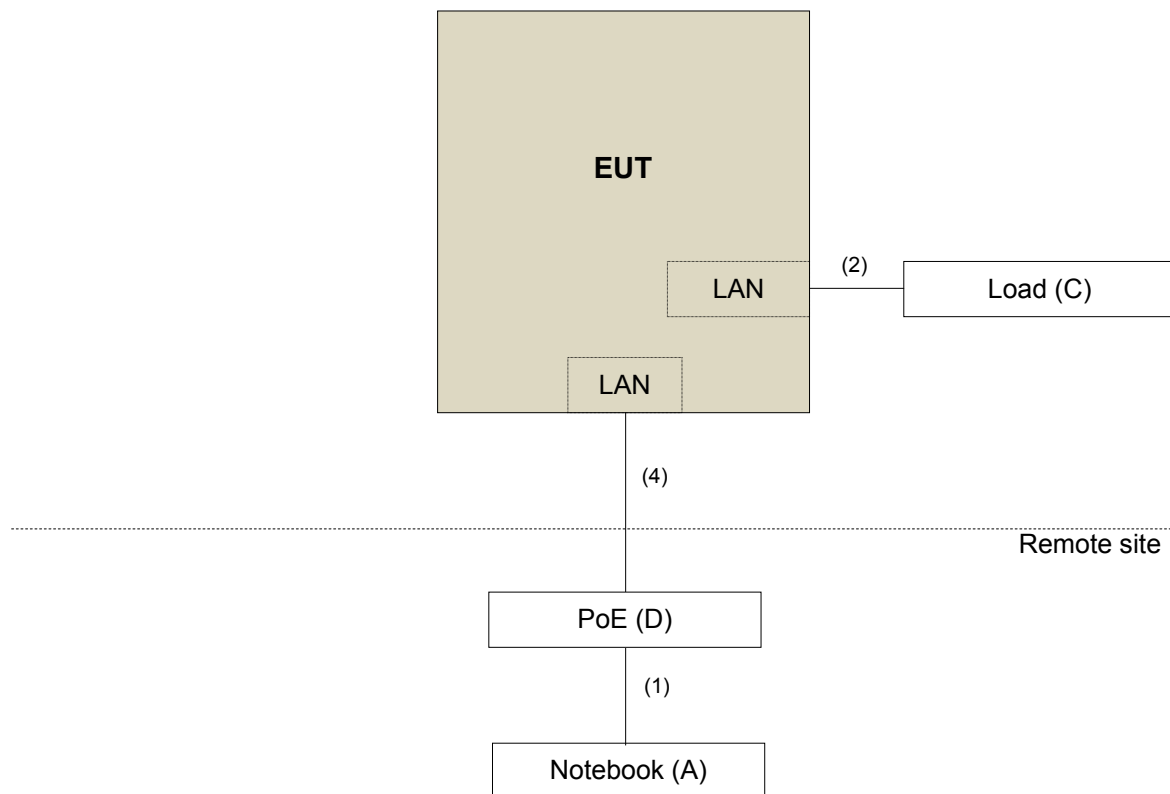

3.5 General Description of Applied Standards

The EUT is a RF Product. According to the specifications of the manufacturer, it must comply with the requirements of the following standards:

FCC Part 15, Subpart E (15.407)

KDB 789033 D02 General UNII Test Procedure New Rules v02r01

KDB 662911 D01 Multiple Transmitter Output v02r01

ANSI C63.10:2013

All test items have been performed and recorded as per the above standards.

4 Test Types and Results

4.1 Radiated Emission and Bandedge Measurement

4.1.1 Limits of Radiated Emission and Bandedge Measurement

Radiated emissions which fall in the restricted bands must comply with the radiated emission limits specified as below table.

Frequencies (MHz)	Field Strength (microvolts/meter)	Measurement Distance (meters)
0.009 ~ 0.490	2400/F(kHz)	300
0.490 ~ 1.705	24000/F(kHz)	30
1.705 ~ 30.0	30	30
30 ~ 88	100	3
88 ~ 216	150	3
216 ~ 960	200	3
Above 960	500	3

NOTE:

1. The lower limit shall apply at the transition frequencies.
2. Emission level (dBuV/m) = 20 log Emission level (uV/m).
3. For frequencies above 1000MHz, the field strength limits are based on average detector, however, the peak field strength of any emission shall not exceed the maximum permitted average limits, specified above by more than 20dB under any condition of modulation.

Limits of unwanted emission out of the restricted bands

Applicable To		Limit	
789033 D02 General UNII Test Procedure New Rules v02r01		Field Strength at 3m	
		PK: 74 (dBµV/m)	AV: 54 (dBµV/m)
Frequency Band	Applicable To	EIRP Limit	Equivalent Field Strength at 3m
5150~5250 MHz	15.407(b)(1)	PK: -27 (dBm/MHz)	PK: 68.2(dBµV/m)
5250~5350 MHz	15.407(b)(2)		
5470~5725 MHz	15.407(b)(3)		
5725~5850 MHz	<input checked="" type="checkbox"/> 15.407(b)(4)(i)	PK: -27 (dBm/MHz) ^{*1} PK: 10 (dBm/MHz) ^{*2} PK: 15.6 (dBm/MHz) ^{*3} PK: 27 (dBm/MHz) ^{*4}	PK: 68.2(dBµV/m) ^{*1} PK: 105.2 (dBµV/m) ^{*2} PK: 110.8(dBµV/m) ^{*3} PK: 122.2 (dBµV/m) ^{*4}
	<input type="checkbox"/> 15.407(b)(4)(ii)	Emission limits in section 15.247(d)	
^{*1} beyond 75 MHz or more above of the band edge.		^{*2} below the band edge increasing linearly to 10 dBm/MHz at 25 MHz above.	
^{*3} below the band edge increasing linearly to a level of 15.6 dBm/MHz at 5 MHz above.		^{*4} from 5 MHz above or below the band edge increasing linearly to a level of 27 dBm/MHz at the band edge.	

Note: The following formula is used to convert the equipment isotropic radiated power (eirp) to field strength:

$$E = \frac{1000000 \sqrt{30P}}{3} \mu\text{V/m, where P is the eirp (Watts).$$

4.1.2 Test Instruments

Description & Manufacturer	Model No.	Serial No.	Cal. Date	Cal. Due
Test Receiver ROHDE & SCHWARZ	ESIB7	100187	May 02, 2017	May 01, 2018
Spectrum Analyzer ROHDE & SCHWARZ	FSP40	100041	Dec. 12, 2017	Dec. 11, 2018
BILOG Antenna SCHWARZBECK	VULB9168	9168-171	Dec. 11, 2017	Dec. 10, 2018
HORN Antenna SCHWARZBECK	9120D	209	Dec. 13, 2017	Dec. 12, 2018
HORN Antenna SCHWARZBECK	BBHA 9170	BBHA9170241	Dec. 01, 2017	Nov. 30, 2018
Loop Antenna EMCI	EM-6879	269	Aug. 11, 2017	Aug. 10, 2018
Preamplifier Agilent (Below 1GHz)	8447D	2944A10738	Aug. 21, 2017	Aug. 20, 2018
Preamplifier Agilent (Above 1GHz)	8449B	3008A02465	Apr. 05, 2017	Apr. 04, 2018
RF signal cable HUBER+SUHNER	SUCOFLEX 104	Cable-CH3-03 (223653/4)	Aug. 21, 2017	Aug. 20, 2018
RF signal cable HUBER+SUHNER& EMCI	SUCOFLEX 104&EMC104-SM-S M-8000	Cable-CH3-03 (309224+170907)	Sep.11, 2017	Sep. 10, 2018
Software BV ADT	ADT_Radiated_ V7.6.15.9.4	NA	NA	NA
Antenna Tower inn-co GmbH	MA 4000	013303	NA	NA
Antenna Tower Controller BV ADT	AT100	AT93021702	NA	NA
Turn Table BV ADT	TT100	TT93021702	NA	NA
Turn Table Controller BV ADT	SC100	SC93021702	NA	NA
Boresight Antenna Fixture	FBA-01	FBA-SIP01	NA	NA
High Speed Peak Power Meter	ML2495A	0824012	Aug. 18, 2017	Aug. 17, 2018
Power Sensor	MA2411B	0738171	Aug. 18, 2017	Aug. 17, 2018
26GHz ~ 40GHz Amplifier Agilent	8449B	3008A1960	Aug. 08, 2017	Aug. 07, 2018

- Note:
1. The calibration interval of the above test instruments is 12 months and the calibrations are traceable to NML/ROC and NIST/USA.
 2. The test was performed in HwaYa Chamber 3.
 3. The horn antenna and preamplifier (model: 8449B) are used only for the measurement of emission frequency above 1GHz if tested.
 4. The FCC Designation Number is TW0003. The number will be varied with the Lab location and scope as attached.
 5. The IC Site Registration No. is IC 7450F-3.

4.1.3 Test Procedures

For Radiated emission below 30MHz

- a. The EUT was placed on the top of a rotating table 0.8 meters above the ground at a 3 meter chamber room. The table was rotated 360 degrees to determine the position of the highest radiation.
- b. The EUT was set 3 meters away from the interference-receiving antenna, which was mounted on the top of a variable-height antenna tower.
- c. Both X and Y axes of the antenna are set to make the measurement.
- d. For each suspected emission, the EUT was arranged to its worst case and the rotatable table was turned from 0 degrees to 360 degrees to find the maximum reading.
- e. The test-receiver system was set to Quasi-Peak Detect Function and Specified Bandwidth with Maximum Hold Mode.

Note:

1. The resolution bandwidth and video bandwidth of test receiver/spectrum analyzer is 9kHz at frequency below 30MHz.

For Radiated emission above 30MHz

- a. The EUT was placed on the top of a rotating table 0.8 meters (for 30MHz ~ 1GHz) / 1.5 meters (for above 1GHz) above the ground at 3 meter chamber room for test. The table was rotated 360 degrees to determine the position of the highest radiation.
- b. The EUT was set 3 meters away from the interference-receiving antenna, which was mounted on the top of a variable-height antenna tower.
- c. The height of antenna is varied from one meter to four meters above the ground to determine the maximum value of the field strength. Both horizontal and vertical polarizations of the antenna are set to make the measurement.
- d. For each suspected emission, the EUT was arranged to its worst case and then the antenna was tuned to heights from 1 meter to 4 meters and the rotatable table was turned from 0 degrees to 360 degrees to find the maximum reading.
- e. The test-receiver system was set to quasi-peak detect function and specified bandwidth with maximum hold mode when the test frequency is below 1 GHz.
- f. The test-receiver system was set to peak and average detect function and specified bandwidth with maximum hold mode when the test frequency is above 1 GHz. If the peak reading value also meets average limit, measurement with the average detector is unnecessary.

Note:

1. The resolution bandwidth and video bandwidth of test receiver/spectrum analyzer is 120kHz for Quasi-peak detection (QP) at frequency below 1GHz.
2. The resolution bandwidth of test receiver/spectrum analyzer is 1 MHz and the video bandwidth is 3 MHz for Peak detection (PK) at frequency above 1GHz.
3. The resolution bandwidth of test receiver/spectrum analyzer is 1MHz and the video bandwidth is $\geq 1/T$ (Duty cycle < 98%) or 10Hz (Duty cycle $\geq 98\%$) for Average detection (AV) at frequency above 1GHz.
4. All modes of operation were investigated and the worst-case emissions are reported.

4.1.4 Deviation from Test Standard

No deviation.

4.1.5 Test Setup

For Radiated emission below 30MHz

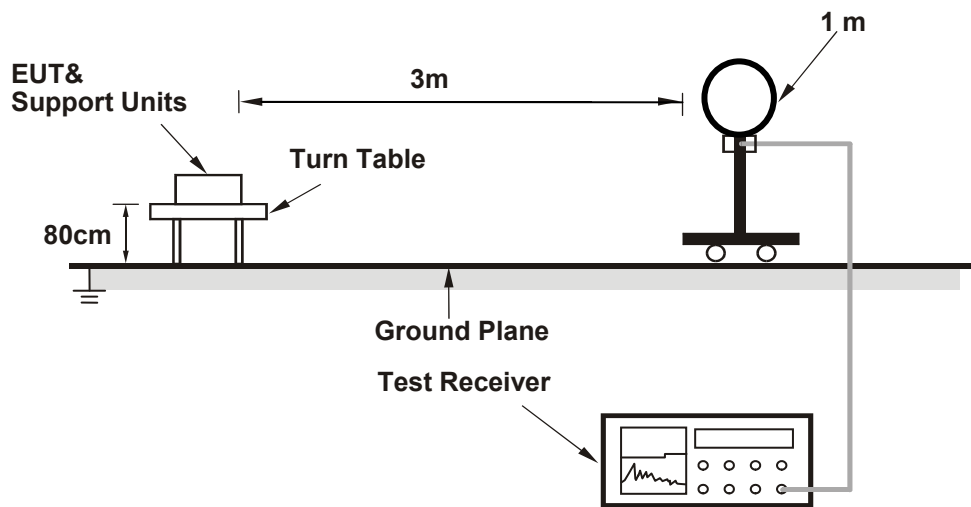

For Radiated emission 30MHz to 1GHz

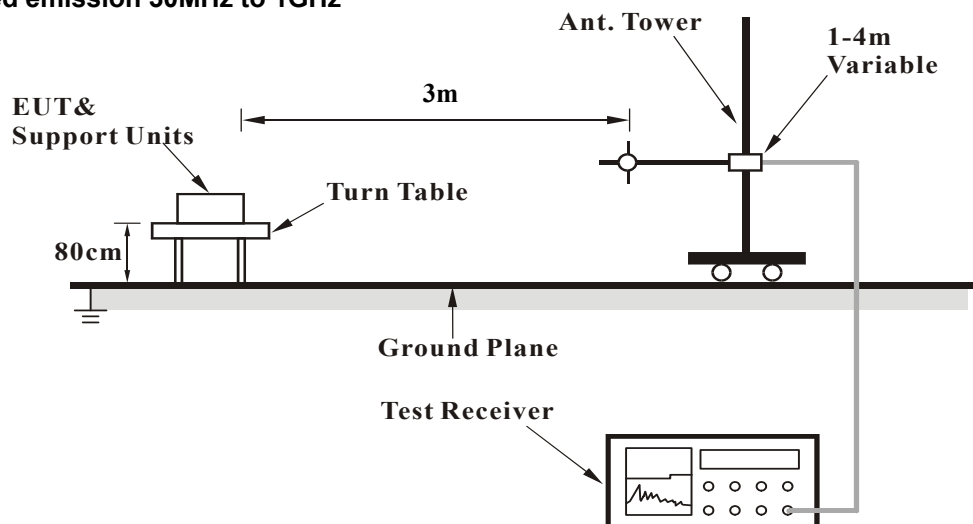

For Radiated emission above 1GHz

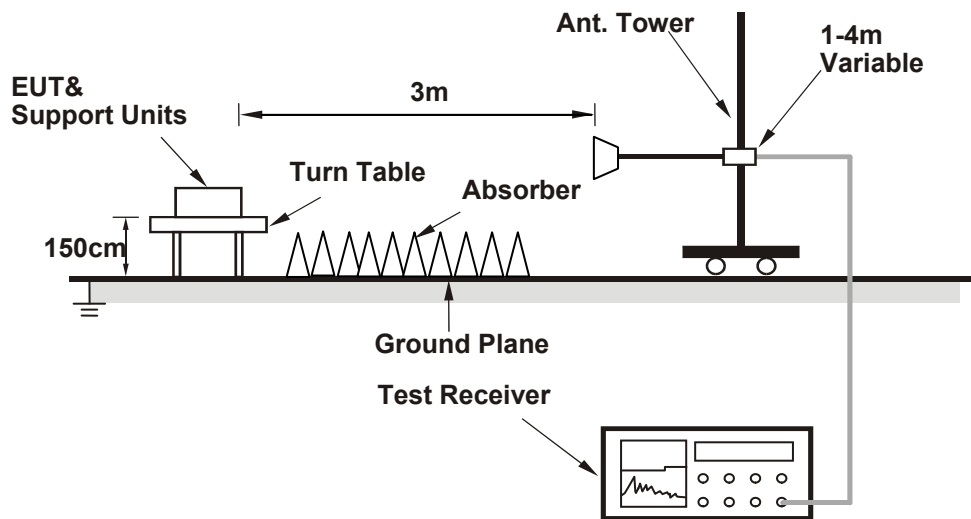

For the actual test configuration, please refer to the attached file (Test Setup Photo).

4.1.6 EUT Operating Conditions

- Placed the EUT on the testing table.
- Prepared a notebook to act as a communication partner and placed it outside of testing area.
- The communication partner connected with EUT via a RJ45 cable and ran a test program (provided by manufacturer) to enable EUT under transmission condition continuously at specific channel frequency.
- The communication partner sent data to EUT by command "PING".

4.1.7 Test Results

Above 1GHz data:

Test Mode A

802.11a

CHANNEL	TX Channel 36	DETECTOR FUNCTION	Peak (PK)
FREQUENCY RANGE	1GHz ~ 40GHz		Average (AV)

ANTENNA POLARITY & TEST DISTANCE: HORIZONTAL AT 3 M

NO.	FREQ. (MHz)	EMISSION LEVEL (dBuV/m)	LIMIT (dBuV/m)	MARGIN (dB)	ANTENNA HEIGHT (m)	TABLE ANGLE (Degree)	RAW VALUE (dBuV)	CORRECTION FACTOR (dB/m)
1	5150.00	71.5 PK	74.0	-2.5	1.07 H	33	67.8	3.7
2	5150.00	52.6 AV	54.0	-1.4	1.07 H	33	48.9	3.7
3	*5180.00	115.9 PK			1.02 H	38	76.3	39.6
4	*5180.00	105.2 AV			1.02 H	38	65.6	39.6
5	#10360.00	58.2 PK	74.0	-15.8	1.58 H	211	42.6	15.6
6	#10360.00	44.6 AV	54.0	-9.4	1.58 H	211	29.0	15.6

ANTENNA POLARITY & TEST DISTANCE: VERTICAL AT 3 M

NO.	FREQ. (MHz)	EMISSION LEVEL (dBuV/m)	LIMIT (dBuV/m)	MARGIN (dB)	ANTENNA HEIGHT (m)	TABLE ANGLE (Degree)	RAW VALUE (dBuV)	CORRECTION FACTOR (dB/m)
1	5150.00	71.9 PK	74.0	-2.1	2.47 V	1	68.2	3.7
2	5150.00	52.7 AV	54.0	-1.3	2.47 V	1	49.0	3.7
3	*5180.00	116.2 PK			2.20 V	358	76.6	39.6
4	*5180.00	105.6 AV			2.20 V	358	66.0	39.6
5	#10360.00	56.2 PK	74.0	-17.8	1.89 V	333	40.6	15.6
6	#10360.00	43.1 AV	54.0	-10.9	1.89 V	333	27.5	15.6

Remarks:

1. Emission Level(dBuV/m) = Raw Value(dBuV) + Correction Factor(dB/m)
2. Correction Factor(dB/m) = Antenna Factor(dB/m) + Cable Factor(dB) – Pre-Amplifier Factor(dB)
3. The other emission levels were very low against the limit.
4. Margin value = Emission Level – Limit value
5. " * ": Fundamental frequency.
6. " # ": The radiated frequency is out of the restricted band.

CHANNEL	TX Channel 40	DETECTOR FUNCTION	Peak (PK)
FREQUENCY RANGE	1GHz ~ 40GHz		Average (AV)

ANTENNA POLARITY & TEST DISTANCE: HORIZONTAL AT 3 M

NO.	FREQ. (MHz)	EMISSION LEVEL (dBuV/m)	LIMIT (dBuV/m)	MARGIN (dB)	ANTENNA HEIGHT (m)	TABLE ANGLE (Degree)	RAW VALUE (dBuV)	CORRECTION FACTOR (dB/m)
1	5150.00	68.0 PK	74.0	-6.0	1.56 H	309	64.3	3.7
2	5150.00	49.7 AV	54.0	-4.3	1.56 H	309	46.0	3.7
3	*5200.00	119.1 PK			1.47 H	311	79.5	39.6
4	*5200.00	108.6 AV			1.47 H	311	69.0	39.6
5	#10400.00	58.6 PK	74.0	-15.4	1.81 H	267	43.0	15.6
6	#10400.00	44.6 AV	54.0	-9.4	1.81 H	267	29.0	15.6

ANTENNA POLARITY & TEST DISTANCE: VERTICAL AT 3 M

NO.	FREQ. (MHz)	EMISSION LEVEL (dBuV/m)	LIMIT (dBuV/m)	MARGIN (dB)	ANTENNA HEIGHT (m)	TABLE ANGLE (Degree)	RAW VALUE (dBuV)	CORRECTION FACTOR (dB/m)
1	5150.00	70.8 PK	74.0	-3.2	2.10 V	356	67.1	3.7
2	5150.00	52.4 AV	54.0	-1.6	2.10 V	356	48.7	3.7
3	*5200.00	120.4 PK			2.08 V	0	80.8	39.6
4	*5200.00	109.5 AV			2.08 V	0	69.9	39.6
5	#10400.00	58.3 PK	74.0	-15.7	1.85 V	320	42.7	15.6
6	#10400.00	44.6 AV	54.0	-9.4	1.85 V	320	29.0	15.6

Remarks:

1. Emission Level(dBuV/m) = Raw Value(dBuV) + Correction Factor(dB/m)
2. Correction Factor(dB/m) = Antenna Factor(dB/m) + Cable Factor(dB) – Pre-Amplifier Factor(dB)
3. The other emission levels were very low against the limit.
4. Margin value = Emission Level – Limit value
5. " * ": Fundamental frequency.
6. " # ": The radiated frequency is out of the restricted band.

CHANNEL	TX Channel 48	DETECTOR FUNCTION	Peak (PK)
FREQUENCY RANGE	1GHz ~ 40GHz		Average (AV)

ANTENNA POLARITY & TEST DISTANCE: HORIZONTAL AT 3 M

NO.	FREQ. (MHz)	EMISSION LEVEL (dBuV/m)	LIMIT (dBuV/m)	MARGIN (dB)	ANTENNA HEIGHT (m)	TABLE ANGLE (Degree)	RAW VALUE (dBuV)	CORRECTION FACTOR (dB/m)
1	5150.00	59.0 PK	74.0	-15.0	1.44 H	51	55.3	3.7
2	5150.00	44.3 AV	54.0	-9.7	1.44 H	51	40.6	3.7
3	*5240.00	120.5 PK			1.27 H	39	81.1	39.4
4	*5240.00	109.8 AV			1.27 H	39	70.4	39.4
5	5350.00	58.8 PK	74.0	-15.2	1.35 H	67	55.0	3.8
6	5350.00	43.9 AV	54.0	-10.1	1.35 H	67	40.1	3.8
7	#10480.00	58.3 PK	74.0	-15.7	1.93 H	222	41.7	16.6
8	#10480.00	45.1 AV	54.0	-8.9	1.93 H	222	28.5	16.6

ANTENNA POLARITY & TEST DISTANCE: VERTICAL AT 3 M

NO.	FREQ. (MHz)	EMISSION LEVEL (dBuV/m)	LIMIT (dBuV/m)	MARGIN (dB)	ANTENNA HEIGHT (m)	TABLE ANGLE (Degree)	RAW VALUE (dBuV)	CORRECTION FACTOR (dB/m)
1	5150.00	58.4 PK	74.0	-15.6	2.15 V	0	54.7	3.7
2	5150.00	44.2 AV	54.0	-9.8	2.15 V	0	40.5	3.7
3	*5240.00	121.9 PK			2.08 V	2	82.5	39.4
4	*5240.00	110.9 AV			2.08 V	2	71.5	39.4
5	5350.00	57.8 PK	74.0	-16.2	1.99 V	10	54.0	3.8
6	5350.00	44.0 AV	54.0	-10.0	1.99 V	10	40.2	3.8
7	#10480.00	58.3 PK	74.0	-15.7	1.79 V	295	41.7	16.6
8	#10480.00	45.1 AV	54.0	-8.9	1.79 V	295	28.5	16.6

Remarks:

1. Emission Level(dBuV/m) = Raw Value(dBuV) + Correction Factor(dB/m)
2. Correction Factor(dB/m) = Antenna Factor(dB/m) + Cable Factor(dB) – Pre-Amplifier Factor(dB)
3. The other emission levels were very low against the limit.
4. Margin value = Emission Level – Limit value
5. " * ": Fundamental frequency.
6. " # ": The radiated frequency is out of the restricted band.

CHANNEL	TX Channel 149	DETECTOR FUNCTION	Peak (PK)
FREQUENCY RANGE	1GHz ~ 40GHz		Average (AV)

ANTENNA POLARITY & TEST DISTANCE: HORIZONTAL AT 3 M								
NO.	FREQ. (MHz)	EMISSION LEVEL (dBuV/m)	LIMIT (dBuV/m)	MARGIN (dB)	ANTENNA HEIGHT (m)	TABLE ANGLE (Degree)	RAW VALUE (dBuV)	CORRECTION FACTOR (dB/m)
1	#5649.60	56.1 PK	68.2	-12.1	1.00 H	41	51.8	4.3
2	*5745.00	118.9 PK			1.00 H	41	78.8	40.1
3	*5745.00	108.1 AV			1.00 H	41	68.0	40.1
4	#5934.40	57.1 PK	68.2	-11.1	1.00 H	41	52.1	5.0
5	11490.00	60.3 PK	74.0	-13.7	2.83 H	165	42.5	17.8
6	11490.00	46.7 AV	54.0	-7.3	2.83 H	165	28.9	17.8
ANTENNA POLARITY & TEST DISTANCE: VERTICAL AT 3 M								
NO.	FREQ. (MHz)	EMISSION LEVEL (dBuV/m)	LIMIT (dBuV/m)	MARGIN (dB)	ANTENNA HEIGHT (m)	TABLE ANGLE (Degree)	RAW VALUE (dBuV)	CORRECTION FACTOR (dB/m)
1	#5624.80	56.5 PK	68.2	-11.7	1.23 V	333	52.3	4.2
2	*5745.00	121.1 PK			1.23 V	333	81.0	40.1
3	*5745.00	110.5 AV			1.23 V	333	70.4	40.1
4	#5929.60	57.0 PK	68.2	-11.2	1.23 V	333	52.0	5.0
5	11490.00	59.7 PK	74.0	-14.3	2.23 V	214	41.9	17.8
6	11490.00	46.8 AV	54.0	-7.2	2.23 V	214	29.0	17.8

Remarks:

1. Emission Level(dBuV/m) = Raw Value(dBuV) + Correction Factor(dB/m)
2. Correction Factor(dB/m) = Antenna Factor(dB/m) + Cable Factor(dB) – Pre-Amplifier Factor(dB)
3. The other emission levels were very low against the limit.
4. Margin value = Emission Level – Limit value
5. " * ": Fundamental frequency.
6. " # ": The radiated frequency is out of the restricted band.

CHANNEL	TX Channel 157	DETECTOR FUNCTION	Peak (PK)
FREQUENCY RANGE	1GHz ~ 40GHz		Average (AV)

ANTENNA POLARITY & TEST DISTANCE: HORIZONTAL AT 3 M

NO.	FREQ. (MHz)	EMISSION LEVEL (dBuV/m)	LIMIT (dBuV/m)	MARGIN (dB)	ANTENNA HEIGHT (m)	TABLE ANGLE (Degree)	RAW VALUE (dBuV)	CORRECTION FACTOR (dB/m)
1	#5611.20	56.8 PK	68.2	-11.4	1.07 H	20	52.6	4.2
2	*5785.00	119.7 PK			1.07 H	20	79.4	40.3
3	*5785.00	108.8 AV			1.07 H	20	68.5	40.3
4	#5947.20	57.8 PK	68.2	-10.4	1.07 H	20	52.8	5.0
5	11570.00	60.7 PK	74.0	-13.3	2.28 H	136	42.6	18.1
6	11570.00	47.1 AV	54.0	-6.9	2.28 H	136	29.0	18.1

ANTENNA POLARITY & TEST DISTANCE: VERTICAL AT 3 M

NO.	FREQ. (MHz)	EMISSION LEVEL (dBuV/m)	LIMIT (dBuV/m)	MARGIN (dB)	ANTENNA HEIGHT (m)	TABLE ANGLE (Degree)	RAW VALUE (dBuV)	CORRECTION FACTOR (dB/m)
1	#5604.80	55.9 PK	68.2	-12.3	1.27 V	332	51.7	4.2
2	*5785.00	121.7 PK			1.27 V	332	81.4	40.3
3	*5785.00	110.8 AV			1.27 V	332	70.5	40.3
4	#5925.60	57.8 PK	68.2	-10.4	1.27 V	332	52.9	4.9
5	11570.00	60.2 PK	74.0	-13.8	1.58 V	212	42.1	18.1
6	11570.00	46.8 AV	54.0	-7.2	1.58 V	212	28.7	18.1

Remarks:

1. Emission Level(dBuV/m) = Raw Value(dBuV) + Correction Factor(dB/m)
2. Correction Factor(dB/m) = Antenna Factor(dB/m) + Cable Factor(dB) – Pre-Amplifier Factor(dB)
3. The other emission levels were very low against the limit.
4. Margin value = Emission Level – Limit value
5. " * ": Fundamental frequency.
6. " # ": The radiated frequency is out of the restricted band.

CHANNEL	TX Channel 165	DETECTOR FUNCTION	Peak (PK)
FREQUENCY RANGE	1GHz ~ 40GHz		Average (AV)

ANTENNA POLARITY & TEST DISTANCE: HORIZONTAL AT 3 M

NO.	FREQ. (MHz)	EMISSION LEVEL (dBuV/m)	LIMIT (dBuV/m)	MARGIN (dB)	ANTENNA HEIGHT (m)	TABLE ANGLE (Degree)	RAW VALUE (dBuV)	CORRECTION FACTOR (dB/m)
1	#5614.40	55.7 PK	68.2	-12.5	1.08 H	45	51.5	4.2
2	*5825.00	119.4 PK			1.08 H	45	78.9	40.5
3	*5825.00	108.8 AV			1.08 H	45	68.3	40.5
4	#5958.40	58.9 PK	68.2	-9.3	1.08 H	45	53.9	5.0
5	11650.00	59.9 PK	74.0	-14.1	1.86 H	231	42.2	17.7
6	11650.00	46.6 AV	54.0	-7.4	1.86 H	231	28.9	17.7

ANTENNA POLARITY & TEST DISTANCE: VERTICAL AT 3 M

NO.	FREQ. (MHz)	EMISSION LEVEL (dBuV/m)	LIMIT (dBuV/m)	MARGIN (dB)	ANTENNA HEIGHT (m)	TABLE ANGLE (Degree)	RAW VALUE (dBuV)	CORRECTION FACTOR (dB/m)
1	#5647.20	56.0 PK	68.2	-12.2	1.12 V	334	51.7	4.3
2	*5825.00	121.9 PK			1.12 V	334	81.4	40.5
3	*5825.00	110.9 AV			1.12 V	334	70.4	40.5
4	#5956.80	57.5 PK	68.2	-10.7	1.12 V	334	52.5	5.0
5	11650.00	59.9 PK	74.0	-14.1	1.84 V	211	42.2	17.7
6	11650.00	46.2 AV	54.0	-7.8	1.84 V	211	28.5	17.7

Remarks:

1. Emission Level(dBuV/m) = Raw Value(dBuV) + Correction Factor(dB/m)
2. Correction Factor(dB/m) = Antenna Factor(dB/m) + Cable Factor(dB) – Pre-Amplifier Factor(dB)
3. The other emission levels were very low against the limit.
4. Margin value = Emission Level – Limit value
5. " * ": Fundamental frequency.
6. " # ": The radiated frequency is out of the restricted band.

802.11n (HT20)

CHANNEL	TX Channel 36	DETECTOR	Peak (PK)
FREQUENCY RANGE	1GHz ~ 40GHz	FUNCTION	Average (AV)

ANTENNA POLARITY & TEST DISTANCE: HORIZONTAL AT 3 M

NO.	FREQ. (MHz)	EMISSION LEVEL (dBuV/m)	LIMIT (dBuV/m)	MARGIN (dB)	ANTENNA HEIGHT (m)	TABLE ANGLE (Degree)	RAW VALUE (dBuV)	CORRECTION FACTOR (dB/m)
1	5150.00	69.1 PK	74.0	-4.9	1.65 H	309	65.4	3.7
2	5150.00	51.7 AV	54.0	-2.3	1.65 H	309	48.0	3.7
3	*5180.00	114.9 PK			1.06 H	63	75.3	39.6
4	*5180.00	104.3 AV			1.06 H	63	64.7	39.6
5	#10360.00	58.0 PK	74.0	-16.0	1.63 H	244	42.4	15.6
6	#10360.00	44.9 AV	54.0	-9.1	1.63 H	244	29.3	15.6

ANTENNA POLARITY & TEST DISTANCE: VERTICAL AT 3 M

NO.	FREQ. (MHz)	EMISSION LEVEL (dBuV/m)	LIMIT (dBuV/m)	MARGIN (dB)	ANTENNA HEIGHT (m)	TABLE ANGLE (Degree)	RAW VALUE (dBuV)	CORRECTION FACTOR (dB/m)
1	5150.00	69.4 PK	74.0	-4.6	1.25 V	8	65.7	3.7
2	5150.00	52.3 AV	54.0	-1.7	1.25 V	8	48.6	3.7
3	*5180.00	116.6 PK			1.96 V	2	77.0	39.6
4	*5180.00	105.4 AV			1.96 V	2	65.8	39.6
5	#10360.00	58.2 PK	74.0	-15.8	1.78 V	282	42.6	15.6
6	#10360.00	45.0 AV	54.0	-9.0	1.78 V	282	29.4	15.6

Remarks:

1. Emission Level(dBuV/m) = Raw Value(dBuV) + Correction Factor(dB/m)
2. Correction Factor(dB/m) = Antenna Factor(dB/m) + Cable Factor(dB) – Pre-Amplifier Factor(dB)
3. The other emission levels were very low against the limit.
4. Margin value = Emission Level – Limit value
5. " * ": Fundamental frequency.
6. " # ": The radiated frequency is out of the restricted band.

CHANNEL	TX Channel 40	DETECTOR FUNCTION	Peak (PK)
FREQUENCY RANGE	1GHz ~ 40GHz		Average (AV)

ANTENNA POLARITY & TEST DISTANCE: HORIZONTAL AT 3 M

NO.	FREQ. (MHz)	EMISSION LEVEL (dBuV/m)	LIMIT (dBuV/m)	MARGIN (dB)	ANTENNA HEIGHT (m)	TABLE ANGLE (Degree)	RAW VALUE (dBuV)	CORRECTION FACTOR (dB/m)
1	5150.00	71.5 PK	74.0	-2.5	1.70 H	313	67.8	3.7
2	5150.00	52.7 AV	54.0	-1.3	1.70 H	313	49.0	3.7
3	*5200.00	119.3 PK			1.30 H	311	79.7	39.6
4	*5200.00	108.5 AV			1.30 H	311	68.9	39.6
5	#10400.00	57.8 PK	74.0	-16.2	1.76 H	267	42.2	15.6
6	#10400.00	44.6 AV	54.0	-9.4	1.76 H	267	29.0	15.6

ANTENNA POLARITY & TEST DISTANCE: VERTICAL AT 3 M

NO.	FREQ. (MHz)	EMISSION LEVEL (dBuV/m)	LIMIT (dBuV/m)	MARGIN (dB)	ANTENNA HEIGHT (m)	TABLE ANGLE (Degree)	RAW VALUE (dBuV)	CORRECTION FACTOR (dB/m)
1	5150.00	69.9 PK	74.0	-4.1	1.10 V	13	66.2	3.7
2	5150.00	52.4 AV	54.0	-1.6	1.10 V	13	48.7	3.7
3	*5200.00	117.8 PK			1.05 V	18	78.2	39.6
4	*5200.00	107.3 AV			1.05 V	18	67.7	39.6
5	#10400.00	57.7 PK	74.0	-16.3	1.83 V	322	42.1	15.6
6	#10400.00	45.0 AV	54.0	-9.0	1.83 V	322	29.4	15.6

Remarks:

1. Emission Level(dBuV/m) = Raw Value(dBuV) + Correction Factor(dB/m)
2. Correction Factor(dB/m) = Antenna Factor(dB/m) + Cable Factor(dB) – Pre-Amplifier Factor(dB)
3. The other emission levels were very low against the limit.
4. Margin value = Emission Level – Limit value
5. " * ": Fundamental frequency.
6. " # ": The radiated frequency is out of the restricted band.

CHANNEL	TX Channel 48	DETECTOR FUNCTION	Peak (PK)
FREQUENCY RANGE	1GHz ~ 40GHz		Average (AV)

ANTENNA POLARITY & TEST DISTANCE: HORIZONTAL AT 3 M								
NO.	FREQ. (MHz)	EMISSION LEVEL (dBuV/m)	LIMIT (dBuV/m)	MARGIN (dB)	ANTENNA HEIGHT (m)	TABLE ANGLE (Degree)	RAW VALUE (dBuV)	CORRECTION FACTOR (dB/m)
1	5150.00	59.3 PK	74.0	-14.7	1.44 H	311	55.6	3.7
2	5150.00	44.5 AV	54.0	-9.5	1.44 H	311	40.8	3.7
3	*5240.00	119.8 PK			1.26 H	318	80.4	39.4
4	*5240.00	108.7 AV			1.26 H	318	69.3	39.4
5	5350.00	58.7 PK	74.0	-15.3	1.33 H	309	54.9	3.8
6	5350.00	44.1 AV	54.0	-9.9	1.33 H	309	40.3	3.8
7	#10480.00	58.8 PK	74.0	-15.2	1.88 H	281	42.2	16.6
8	#10480.00	45.1 AV	54.0	-8.9	1.88 H	281	28.5	16.6

ANTENNA POLARITY & TEST DISTANCE: VERTICAL AT 3 M								
NO.	FREQ. (MHz)	EMISSION LEVEL (dBuV/m)	LIMIT (dBuV/m)	MARGIN (dB)	ANTENNA HEIGHT (m)	TABLE ANGLE (Degree)	RAW VALUE (dBuV)	CORRECTION FACTOR (dB/m)
1	5150.00	59.9 PK	74.0	-14.1	1.93 V	357	56.2	3.7
2	5150.00	44.8 AV	54.0	-9.2	1.93 V	357	41.1	3.7
3	*5240.00	122.4 PK			1.94 V	1	83.0	39.4
4	*5240.00	111.2 AV			1.94 V	1	71.8	39.4
5	5350.00	59.6 PK	74.0	-14.4	1.88 V	355	55.8	3.8
6	5350.00	44.3 AV	54.0	-9.7	1.88 V	355	40.5	3.8
7	#10480.00	59.0 PK	74.0	-15.0	1.89 V	267	42.4	16.6
8	#10480.00	45.6 AV	54.0	-8.4	1.89 V	267	29.0	16.6

Remarks:

1. Emission Level(dBuV/m) = Raw Value(dBuV) + Correction Factor(dB/m)
2. Correction Factor(dB/m) = Antenna Factor(dB/m) + Cable Factor(dB) – Pre-Amplifier Factor(dB)
3. The other emission levels were very low against the limit.
4. Margin value = Emission Level – Limit value
5. " * ": Fundamental frequency.
6. " # ": The radiated frequency is out of the restricted band.

CHANNEL	TX Channel 149	DETECTOR FUNCTION	Peak (PK)
FREQUENCY RANGE	1GHz ~ 40GHz		Average (AV)

ANTENNA POLARITY & TEST DISTANCE: HORIZONTAL AT 3 M								
NO.	FREQ. (MHz)	EMISSION LEVEL (dBuV/m)	LIMIT (dBuV/m)	MARGIN (dB)	ANTENNA HEIGHT (m)	TABLE ANGLE (Degree)	RAW VALUE (dBuV)	CORRECTION FACTOR (dB/m)
1	#5620.80	56.1 PK	68.2	-12.1	1.08 H	20	51.9	4.2
2	*5745.00	119.8 PK			1.08 H	20	79.7	40.1
3	*5745.00	108.7 AV			1.08 H	20	68.6	40.1
4	#5946.40	57.9 PK	68.2	-10.3	1.08 H	20	52.9	5.0
5	11490.00	60.6 PK	74.0	-13.4	1.86 H	217	42.8	17.8
6	11490.00	47.0 AV	54.0	-7.0	1.86 H	217	29.2	17.8

ANTENNA POLARITY & TEST DISTANCE: VERTICAL AT 3 M								
NO.	FREQ. (MHz)	EMISSION LEVEL (dBuV/m)	LIMIT (dBuV/m)	MARGIN (dB)	ANTENNA HEIGHT (m)	TABLE ANGLE (Degree)	RAW VALUE (dBuV)	CORRECTION FACTOR (dB/m)
1	#5640.80	56.4 PK	68.2	-11.8	1.23 V	332	52.2	4.2
2	*5745.00	121.0 PK			1.23 V	332	80.9	40.1
3	*5745.00	110.2 AV			1.23 V	332	70.1	40.1
4	#5932.00	57.3 PK	68.2	-10.9	1.23 V	332	52.3	5.0
5	11490.00	60.1 PK	74.0	-13.9	1.84 V	231	42.3	17.8
6	11490.00	46.5 AV	54.0	-7.5	1.84 V	231	28.7	17.8

Remarks:

1. Emission Level(dBuV/m) = Raw Value(dBuV) + Correction Factor(dB/m)
2. Correction Factor(dB/m) = Antenna Factor(dB/m) + Cable Factor(dB) – Pre-Amplifier Factor(dB)
3. The other emission levels were very low against the limit.
4. Margin value = Emission Level – Limit value
5. " * ": Fundamental frequency.
6. " # ": The radiated frequency is out of the restricted band.

CHANNEL	TX Channel 157	DETECTOR FUNCTION	Peak (PK)
FREQUENCY RANGE	1GHz ~ 40GHz		Average (AV)

ANTENNA POLARITY & TEST DISTANCE: HORIZONTAL AT 3 M								
NO.	FREQ. (MHz)	EMISSION LEVEL (dBuV/m)	LIMIT (dBuV/m)	MARGIN (dB)	ANTENNA HEIGHT (m)	TABLE ANGLE (Degree)	RAW VALUE (dBuV)	CORRECTION FACTOR (dB/m)
1	#5626.40	56.3 PK	68.2	-11.9	1.06 H	21	52.1	4.2
2	*5785.00	119.7 PK			1.06 H	21	79.4	40.3
3	*5785.00	108.7 AV			1.06 H	21	68.4	40.3
4	#5940.80	58.4 PK	68.2	-9.8	1.06 H	21	53.5	4.9
5	11570.00	60.4 PK	74.0	-13.6	1.68 H	263	42.3	18.1
6	11570.00	47.1 AV	54.0	-6.9	1.68 H	263	29.0	18.1

ANTENNA POLARITY & TEST DISTANCE: VERTICAL AT 3 M								
NO.	FREQ. (MHz)	EMISSION LEVEL (dBuV/m)	LIMIT (dBuV/m)	MARGIN (dB)	ANTENNA HEIGHT (m)	TABLE ANGLE (Degree)	RAW VALUE (dBuV)	CORRECTION FACTOR (dB/m)
1	#5648.80	56.4 PK	68.2	-11.8	1.37 V	336	52.1	4.3
2	*5785.00	121.7 PK			1.37 V	336	81.4	40.3
3	*5785.00	110.6 AV			1.37 V	336	70.3	40.3
4	#5955.20	57.4 PK	68.2	-10.8	1.37 V	336	52.4	5.0
5	11570.00	60.1 PK	74.0	-13.9	2.01 V	149	42.0	18.1
6	11570.00	46.7 AV	54.0	-7.3	2.01 V	149	28.6	18.1

Remarks:

1. Emission Level(dBuV/m) = Raw Value(dBuV) + Correction Factor(dB/m)
2. Correction Factor(dB/m) = Antenna Factor(dB/m) + Cable Factor(dB) – Pre-Amplifier Factor(dB)
3. The other emission levels were very low against the limit.
4. Margin value = Emission Level – Limit value
5. " * ": Fundamental frequency.
6. " # ": The radiated frequency is out of the restricted band.

CHANNEL	TX Channel 165	DETECTOR FUNCTION	Peak (PK)
FREQUENCY RANGE	1GHz ~ 40GHz		Average (AV)

ANTENNA POLARITY & TEST DISTANCE: HORIZONTAL AT 3 M

NO.	FREQ. (MHz)	EMISSION LEVEL (dBuV/m)	LIMIT (dBuV/m)	MARGIN (dB)	ANTENNA HEIGHT (m)	TABLE ANGLE (Degree)	RAW VALUE (dBuV)	CORRECTION FACTOR (dB/m)
1	#5640.00	56.0 PK	68.2	-12.2	1.00 H	18	51.8	4.2
2	*5825.00	120.5 PK			1.00 H	18	80.0	40.5
3	*5825.00	109.4 AV			1.00 H	18	68.9	40.5
4	#5936.80	59.2 PK	68.2	-9.0	1.00 H	18	54.3	4.9
5	11650.00	59.0 PK	74.0	-15.0	2.61 H	163	41.3	17.7
6	11650.00	46.5 AV	54.0	-7.5	2.61 H	163	28.8	17.7

ANTENNA POLARITY & TEST DISTANCE: VERTICAL AT 3 M

NO.	FREQ. (MHz)	EMISSION LEVEL (dBuV/m)	LIMIT (dBuV/m)	MARGIN (dB)	ANTENNA HEIGHT (m)	TABLE ANGLE (Degree)	RAW VALUE (dBuV)	CORRECTION FACTOR (dB/m)
1	#5636.80	55.6 PK	68.2	-12.6	1.31 V	333	51.4	4.2
2	*5825.00	121.4 PK			1.31 V	333	80.9	40.5
3	*5825.00	110.5 AV			1.31 V	333	70.0	40.5
4	#5944.80	57.4 PK	68.2	-10.8	1.31 V	333	52.4	5.0
5	11650.00	59.3 PK	74.0	-14.7	2.14 V	186	41.6	17.7
6	11650.00	46.1 AV	54.0	-7.9	2.14 V	186	28.4	17.7

Remarks:

1. Emission Level(dBuV/m) = Raw Value(dBuV) + Correction Factor(dB/m)
2. Correction Factor(dB/m) = Antenna Factor(dB/m) + Cable Factor(dB) – Pre-Amplifier Factor(dB)
3. The other emission levels were very low against the limit.
4. Margin value = Emission Level – Limit value
5. " * ": Fundamental frequency.
6. " # ": The radiated frequency is out of the restricted band.

802.11n (HT40)

CHANNEL	TX Channel 38	DETECTOR FUNCTION	Peak (PK) Average (AV)
FREQUENCY RANGE	1GHz ~ 40GHz		

ANTENNA POLARITY & TEST DISTANCE: HORIZONTAL AT 3 M								
NO.	FREQ. (MHz)	EMISSION LEVEL (dBuV/m)	LIMIT (dBuV/m)	MARGIN (dB)	ANTENNA HEIGHT (m)	TABLE ANGLE (Degree)	RAW VALUE (dBuV)	CORRECTION FACTOR (dB/m)
1	5150.00	68.0 PK	74.0	-6.0	1.23 H	35	64.3	3.7
2	5150.00	52.4 AV	54.0	-1.6	1.23 H	35	48.7	3.7
3	*5190.00	110.3 PK			1.46 H	312	70.7	39.6
4	*5190.00	99.8 AV			1.46 H	312	60.2	39.6
5	#10380.00	57.6 PK	74.0	-16.4	1.77 H	333	42.0	15.6
6	#10380.00	44.9 AV	54.0	-9.1	1.77 H	333	29.3	15.6
ANTENNA POLARITY & TEST DISTANCE: VERTICAL AT 3 M								
NO.	FREQ. (MHz)	EMISSION LEVEL (dBuV/m)	LIMIT (dBuV/m)	MARGIN (dB)	ANTENNA HEIGHT (m)	TABLE ANGLE (Degree)	RAW VALUE (dBuV)	CORRECTION FACTOR (dB/m)
1	5150.00	67.9 PK	74.0	-6.1	2.11 V	358	64.2	3.7
2	5150.00	52.4 AV	54.0	-1.6	2.11 V	358	48.7	3.7
3	*5190.00	109.9 PK			2.20 V	358	70.3	39.6
4	*5190.00	99.8 AV			2.20 V	358	60.2	39.6
5	#10380.00	55.9 PK	74.0	-18.1	1.91 V	319	40.3	15.6
6	#10380.00	42.1 AV	54.0	-11.9	1.91 V	319	26.5	15.6

Remarks:

1. Emission Level(dBuV/m) = Raw Value(dBuV) + Correction Factor(dB/m)
2. Correction Factor(dB/m) = Antenna Factor(dB/m) + Cable Factor(dB) – Pre-Amplifier Factor(dB)
3. The other emission levels were very low against the limit.
4. Margin value = Emission Level – Limit value
5. " * ": Fundamental frequency.
6. " # ": The radiated frequency is out of the restricted band.

CHANNEL	TX Channel 46	DETECTOR FUNCTION	Peak (PK)
FREQUENCY RANGE	1GHz ~ 40GHz		Average (AV)

ANTENNA POLARITY & TEST DISTANCE: HORIZONTAL AT 3 M								
NO.	FREQ. (MHz)	EMISSION LEVEL (dBuV/m)	LIMIT (dBuV/m)	MARGIN (dB)	ANTENNA HEIGHT (m)	TABLE ANGLE (Degree)	RAW VALUE (dBuV)	CORRECTION FACTOR (dB/m)
1	5150.00	66.6 PK	74.0	-7.4	1.12 H	30	62.9	3.7
2	5150.00	50.1 AV	54.0	-3.9	1.12 H	30	46.4	3.7
3	*5230.00	114.0 PK			1.17 H	316	74.6	39.4
4	*5230.00	104.0 AV			1.17 H	316	64.6	39.4
5	5350.00	65.5 PK	74.0	-8.5	1.23 H	22	61.7	3.8
6	5350.00	49.6 AV	54.0	-4.4	1.23 H	22	45.8	3.8
7	#10460.00	58.2 PK	74.0	-15.8	1.91 H	293	42.0	16.2
8	#10460.00	45.3 AV	54.0	-8.7	1.91 H	293	29.1	16.2

ANTENNA POLARITY & TEST DISTANCE: VERTICAL AT 3 M								
NO.	FREQ. (MHz)	EMISSION LEVEL (dBuV/m)	LIMIT (dBuV/m)	MARGIN (dB)	ANTENNA HEIGHT (m)	TABLE ANGLE (Degree)	RAW VALUE (dBuV)	CORRECTION FACTOR (dB/m)
1	5150.00	68.8 PK	74.0	-5.2	2.26 V	1	65.1	3.7
2	5150.00	52.4 AV	54.0	-1.6	2.26 V	1	48.7	3.7
3	*5230.00	116.1 PK			2.07 V	0	76.7	39.4
4	*5230.00	105.6 AV			2.07 V	0	66.2	39.4
5	5350.00	68.3 PK	74.0	-5.7	1.99 V	354	64.5	3.8
6	5350.00	51.6 AV	54.0	-2.4	1.99 V	354	47.8	3.8
7	#10460.00	58.3 PK	74.0	-15.7	1.73 V	327	42.1	16.2
8	#10460.00	45.2 AV	54.0	-8.8	1.73 V	327	29.0	16.2

Remarks:

1. Emission Level(dBuV/m) = Raw Value(dBuV) + Correction Factor(dB/m)
2. Correction Factor(dB/m) = Antenna Factor(dB/m) + Cable Factor(dB) – Pre-Amplifier Factor(dB)
3. The other emission levels were very low against the limit.
4. Margin value = Emission Level – Limit value
5. " * ": Fundamental frequency.
6. " # ": The radiated frequency is out of the restricted band.

CHANNEL	TX Channel 151	DETECTOR FUNCTION	Peak (PK)
FREQUENCY RANGE	1GHz ~ 40GHz		Average (AV)

ANTENNA POLARITY & TEST DISTANCE: HORIZONTAL AT 3 M								
NO.	FREQ. (MHz)	EMISSION LEVEL (dBuV/m)	LIMIT (dBuV/m)	MARGIN (dB)	ANTENNA HEIGHT (m)	TABLE ANGLE (Degree)	RAW VALUE (dBuV)	CORRECTION FACTOR (dB/m)
1	#5648.80	63.0 PK	68.2	-5.2	1.18 H	19	58.7	4.3
2	#5650.00	65.8 PK	68.2	-2.4	1.03 H	58	61.5	4.3
3	*5755.00	117.8 PK			1.18 H	19	77.7	40.1
4	*5755.00	106.9 AV			1.18 H	19	66.8	40.1
5	#5931.20	59.4 PK	68.2	-8.8	1.18 H	19	54.4	5.0
6	11510.00	60.3 PK	74.0	-13.7	1.66 H	231	42.5	17.8
7	11510.00	47.1 AV	54.0	-6.9	1.66 H	231	29.3	17.8

ANTENNA POLARITY & TEST DISTANCE: VERTICAL AT 3 M								
NO.	FREQ. (MHz)	EMISSION LEVEL (dBuV/m)	LIMIT (dBuV/m)	MARGIN (dB)	ANTENNA HEIGHT (m)	TABLE ANGLE (Degree)	RAW VALUE (dBuV)	CORRECTION FACTOR (dB/m)
1	#5649.60	63.8 PK	68.2	-4.4	1.03 V	6	59.5	4.3
2	#5650.00	66.5 PK	68.2	-1.7	1.04 V	330	62.2	4.3
3	*5755.00	119.2 PK			1.03 V	6	79.1	40.1
4	*5755.00	108.5 AV			1.03 V	6	68.4	40.1
5	#5932.00	58.1 PK	68.2	-10.1	1.03 V	6	53.1	5.0
6	11510.00	59.9 PK	74.0	-14.1	1.89 V	214	42.1	17.8
7	11510.00	46.3 AV	54.0	-7.7	1.89 V	214	28.5	17.8

Remarks:

1. Emission Level(dBuV/m) = Raw Value(dBuV) + Correction Factor(dB/m)
2. Correction Factor(dB/m) = Antenna Factor(dB/m) + Cable Factor(dB) – Pre-Amplifier Factor(dB)
3. The other emission levels were very low against the limit.
4. Margin value = Emission Level – Limit value
5. " * ": Fundamental frequency.
6. " # ": The radiated frequency is out of the restricted band.

CHANNEL	TX Channel 159	DETECTOR FUNCTION	Peak (PK)
FREQUENCY RANGE	1GHz ~ 40GHz		Average (AV)

ANTENNA POLARITY & TEST DISTANCE: HORIZONTAL AT 3 M								
NO.	FREQ. (MHz)	EMISSION LEVEL (dBuV/m)	LIMIT (dBuV/m)	MARGIN (dB)	ANTENNA HEIGHT (m)	TABLE ANGLE (Degree)	RAW VALUE (dBuV)	CORRECTION FACTOR (dB/m)
1	#5648.00	58.6 PK	68.2	-9.6	1.00 H	41	54.3	4.3
2	*5795.00	117.7 PK			1.00 H	41	77.4	40.3
3	*5795.00	106.8 AV			1.00 H	41	66.5	40.3
4	#5925.00	66.7 PK	68.2	-1.5	1.08 H	57	61.8	4.9
5	#5926.40	63.1 PK	68.2	-5.1	1.00 H	41	58.2	4.9
6	11590.00	60.6 PK	74.0	-13.4	1.84 H	261	42.6	18.0
7	11590.00	47.3 AV	54.0	-6.7	1.84 H	261	29.3	18.0

ANTENNA POLARITY & TEST DISTANCE: VERTICAL AT 3 M								
NO.	FREQ. (MHz)	EMISSION LEVEL (dBuV/m)	LIMIT (dBuV/m)	MARGIN (dB)	ANTENNA HEIGHT (m)	TABLE ANGLE (Degree)	RAW VALUE (dBuV)	CORRECTION FACTOR (dB/m)
1	#5636.80	59.6 PK	68.2	-8.6	1.47 V	334	55.4	4.2
2	*5795.00	119.1 PK			1.47 V	334	78.8	40.3
3	*5795.00	108.1 AV			1.47 V	334	67.8	40.3
4	#5925.00	66.2 PK	68.2	-2.0	2.16 V	338	61.3	4.9
5	#5926.40	61.7 PK	68.2	-6.5	1.47 V	334	56.8	4.9
6	11590.00	60.2 PK	74.0	-13.8	1.78 V	254	42.2	18.0
7	11590.00	46.5 AV	54.0	-7.5	1.78 V	254	28.5	18.0

Remarks:

1. Emission Level(dBuV/m) = Raw Value(dBuV) + Correction Factor(dB/m)
2. Correction Factor(dB/m) = Antenna Factor(dB/m) + Cable Factor(dB) – Pre-Amplifier Factor(dB)
3. The other emission levels were very low against the limit.
4. Margin value = Emission Level – Limit value
5. " * ": Fundamental frequency.
6. " # ": The radiated frequency is out of the restricted band.

802.11ac (VHT80)

CHANNEL	TX Channel 42	DETECTOR FUNCTION	Peak (PK)
FREQUENCY RANGE	1GHz ~ 40GHz		Average (AV)

ANTENNA POLARITY & TEST DISTANCE: HORIZONTAL AT 3 M

NO.	FREQ. (MHz)	EMISSION LEVEL (dBuV/m)	LIMIT (dBuV/m)	MARGIN (dB)	ANTENNA HEIGHT (m)	TABLE ANGLE (Degree)	RAW VALUE (dBuV)	CORRECTION FACTOR (dB/m)
1	5150.00	65.2 PK	74.0	-8.8	1.10 H	33	61.5	3.7
2	5150.00	52.1 AV	54.0	-1.9	1.10 H	33	48.4	3.7
3	*5210.00	105.4 PK			1.28 H	316	65.9	39.5
4	*5210.00	95.4 AV			1.28 H	316	55.9	39.5
5	5350.00	51.5 PK	74.0	-22.5	1.21 H	47	47.7	3.8
6	5350.00	39.0 AV	54.0	-15.0	1.21 H	47	35.2	3.8
7	#10420.00	57.6 PK	74.0	-16.4	1.71 H	288	41.8	15.8
8	#10420.00	44.7 AV	54.0	-9.3	1.71 H	288	28.9	15.8

ANTENNA POLARITY & TEST DISTANCE: VERTICAL AT 3 M

NO.	FREQ. (MHz)	EMISSION LEVEL (dBuV/m)	LIMIT (dBuV/m)	MARGIN (dB)	ANTENNA HEIGHT (m)	TABLE ANGLE (Degree)	RAW VALUE (dBuV)	CORRECTION FACTOR (dB/m)
1	5150.00	66.1 PK	74.0	-7.9	2.21 V	0	62.4	3.7
2	5150.00	52.3 AV	54.0	-1.7	2.21 V	0	48.6	3.7
3	*5210.00	106.5 PK			2.17 V	359	67.0	39.5
4	*5210.00	96.1 AV			2.17 V	359	56.6	39.5
5	5350.00	56.6 PK	74.0	-17.4	2.19 V	3	52.8	3.8
6	5350.00	43.9 AV	54.0	-10.1	2.19 V	3	40.1	3.8
7	#10420.00	57.8 PK	74.0	-16.2	1.88 V	293	42.0	15.8
8	#10420.00	44.9 AV	54.0	-9.1	1.88 V	293	29.1	15.8

Remarks:

1. Emission Level(dBuV/m) = Raw Value(dBuV) + Correction Factor(dB/m)
2. Correction Factor(dB/m) = Antenna Factor(dB/m) + Cable Factor(dB) – Pre-Amplifier Factor(dB)
3. The other emission levels were very low against the limit.
4. Margin value = Emission Level – Limit value
5. " * ": Fundamental frequency.
6. " # ": The radiated frequency is out of the restricted band.

CHANNEL	TX Channel 155	DETECTOR FUNCTION	Peak (PK)
FREQUENCY RANGE	1GHz ~ 40GHz		Average (AV)

ANTENNA POLARITY & TEST DISTANCE: HORIZONTAL AT 3 M								
NO.	FREQ. (MHz)	EMISSION LEVEL (dBuV/m)	LIMIT (dBuV/m)	MARGIN (dB)	ANTENNA HEIGHT (m)	TABLE ANGLE (Degree)	RAW VALUE (dBuV)	CORRECTION FACTOR (dB/m)
1	#5639.20	62.9 PK	68.2	-5.3	1.05 H	20	58.7	4.2
2	#5650.00	66.3 PK	68.2	-1.9	1.53 H	22	62.0	4.3
3	*5775.00	110.8 PK			1.05 H	20	70.6	40.2
4	*5775.00	100.4 AV			1.05 H	20	60.2	40.2
5	#5925.00	63.8 PK	68.2	-4.4	1.22 H	26	58.9	4.9
6	#5940.00	62.3 PK	68.2	-5.9	1.05 H	20	57.4	4.9
7	11550.00	59.4 PK	74.0	-14.6	2.67 H	148	41.4	18.0
8	11550.00	46.3 AV	54.0	-7.7	2.67 H	148	28.3	18.0
ANTENNA POLARITY & TEST DISTANCE: VERTICAL AT 3 M								
NO.	FREQ. (MHz)	EMISSION LEVEL (dBuV/m)	LIMIT (dBuV/m)	MARGIN (dB)	ANTENNA HEIGHT (m)	TABLE ANGLE (Degree)	RAW VALUE (dBuV)	CORRECTION FACTOR (dB/m)
1	#5649.60	63.4 PK	68.2	-4.8	1.39 V	334	59.1	4.3
2	#5650.00	67.0 PK	68.2	-1.2	1.14 V	332	62.7	4.3
3	*5775.00	112.6 PK			1.39 V	334	72.4	40.2
4	*5775.00	102.2 AV			1.39 V	334	62.0	40.2
5	#5925.00	65.7 PK	68.2	-2.5	2.45 V	336	60.8	4.9
6	#5932.00	63.3 PK	68.2	-4.9	1.39 V	334	58.3	5.0
7	11550.00	60.0 PK	74.0	-14.0	1.77 V	264	42.0	18.0
8	11550.00	46.6 AV	54.0	-7.4	1.77 V	264	28.6	18.0

Remarks:

1. Emission Level(dBuV/m) = Raw Value(dBuV) + Correction Factor(dB/m)
2. Correction Factor(dB/m) = Antenna Factor(dB/m) + Cable Factor(dB) – Pre-Amplifier Factor(dB)
3. The other emission levels were very low against the limit.
4. Margin value = Emission Level – Limit value
5. " * ": Fundamental frequency.
6. " # ": The radiated frequency is out of the restricted band.

Test Mode C

802.11a

CHANNEL	TX Channel 36	DETECTOR FUNCTION	Peak (PK)
FREQUENCY RANGE	1GHz ~ 40GHz		Average (AV)

ANTENNA POLARITY & TEST DISTANCE: HORIZONTAL AT 3 M

NO.	FREQ. (MHz)	EMISSION LEVEL (dBuV/m)	LIMIT (dBuV/m)	MARGIN (dB)	ANTENNA HEIGHT (m)	TABLE ANGLE (Degree)	RAW VALUE (dBuV)	CORRECTION FACTOR (dB/m)
1	5150.00	62.6 PK	74.0	-11.4	1.67 H	334	58.9	3.7
2	5150.00	47.0 AV	54.0	-7.0	1.67 H	334	43.3	3.7
3	*5180.00	105.4 PK			2.12 H	351	65.8	39.6
4	*5180.00	95.2 AV			2.12 H	351	55.6	39.6
5	#6906.00	57.5 PK	68.2	-10.7	1.55 H	340	48.4	9.1
6	#10360.00	64.9 PK	74.0	-9.1	2.16 H	333	49.3	15.6
7	#10360.00	52.3 AV	54.0	-1.7	2.16 H	333	36.7	15.6

ANTENNA POLARITY & TEST DISTANCE: VERTICAL AT 3 M

NO.	FREQ. (MHz)	EMISSION LEVEL (dBuV/m)	LIMIT (dBuV/m)	MARGIN (dB)	ANTENNA HEIGHT (m)	TABLE ANGLE (Degree)	RAW VALUE (dBuV)	CORRECTION FACTOR (dB/m)
1	5150.00	66.6 PK	74.0	-7.4	2.01 V	1	62.9	3.7
2	5150.00	50.4 AV	54.0	-3.6	2.01 V	1	46.7	3.7
3	*5180.00	110.6 PK			1.66 V	352	71.0	39.6
4	*5180.00	100.5 AV			1.66 V	352	60.9	39.6
5	#6906.00	57.8 PK	68.2	-10.4	1.66 V	358	48.7	9.1
6	#10360.00	58.5 PK	74.0	-15.5	1.49 V	286	42.9	15.6
7	#10360.00	45.4 AV	54.0	-8.6	1.49 V	286	29.8	15.6

Remarks:

1. Emission Level(dBuV/m) = Raw Value(dBuV) + Correction Factor(dB/m)
2. Correction Factor(dB/m) = Antenna Factor(dB/m) + Cable Factor(dB) – Pre-Amplifier Factor(dB)
3. The other emission levels were very low against the limit.
4. Margin value = Emission Level – Limit value
5. " * ": Fundamental frequency.
6. " # ": The radiated frequency is out of the restricted band.

CHANNEL	TX Channel 40	DETECTOR FUNCTION	Peak (PK)
FREQUENCY RANGE	1GHz ~ 40GHz		Average (AV)

ANTENNA POLARITY & TEST DISTANCE: HORIZONTAL AT 3 M								
NO.	FREQ. (MHz)	EMISSION LEVEL (dBuV/m)	LIMIT (dBuV/m)	MARGIN (dB)	ANTENNA HEIGHT (m)	TABLE ANGLE (Degree)	RAW VALUE (dBuV)	CORRECTION FACTOR (dB/m)
1	*5200.00	105.3 PK			1.92 H	347	65.7	39.6
2	*5200.00	95.2 AV			1.92 H	347	55.6	39.6
3	#6933.00	55.8 PK	68.2	-12.4	1.56 H	341	46.5	9.3
4	#10400.00	66.3 PK	74.0	-7.7	2.08 H	334	50.7	15.6
5	#10400.00	52.6 AV	54.0	-1.4	2.08 H	334	37.0	15.6

ANTENNA POLARITY & TEST DISTANCE: VERTICAL AT 3 M								
NO.	FREQ. (MHz)	EMISSION LEVEL (dBuV/m)	LIMIT (dBuV/m)	MARGIN (dB)	ANTENNA HEIGHT (m)	TABLE ANGLE (Degree)	RAW VALUE (dBuV)	CORRECTION FACTOR (dB/m)
1	*5200.00	111.2 PK			1.74 V	354	71.6	39.6
2	*5200.00	101.1 AV			1.74 V	354	61.5	39.6
3	#6933.00	56.4 PK	68.2	-11.8	1.67 V	333	47.1	9.3
4	#10400.00	58.7 PK	74.0	-15.3	1.45 V	280	43.1	15.6
5	#10400.00	45.8 AV	54.0	-8.2	1.45 V	280	30.2	15.6

Remarks:

1. Emission Level(dBuV/m) = Raw Value(dBuV) + Correction Factor(dB/m)
2. Correction Factor(dB/m) = Antenna Factor(dB/m) + Cable Factor(dB) – Pre-Amplifier Factor(dB)
3. The other emission levels were very low against the limit.
4. Margin value = Emission Level – Limit value
5. " * ": Fundamental frequency.
6. " # ": The radiated frequency is out of the restricted band.

CHANNEL	TX Channel 48	DETECTOR FUNCTION	Peak (PK)
FREQUENCY RANGE	1GHz ~ 40GHz		Average (AV)

ANTENNA POLARITY & TEST DISTANCE: HORIZONTAL AT 3 M

NO.	FREQ. (MHz)	EMISSION LEVEL (dBuV/m)	LIMIT (dBuV/m)	MARGIN (dB)	ANTENNA HEIGHT (m)	TABLE ANGLE (Degree)	RAW VALUE (dBuV)	CORRECTION FACTOR (dB/m)
1	*5240.00	104.8 PK			1.98 H	345	65.4	39.4
2	*5240.00	94.3 AV			1.98 H	345	54.9	39.4
3	5350.00	54.2 PK	74.0	-19.8	2.01 H	303	50.4	3.8
4	5350.00	44.5 AV	54.0	-9.5	2.01 H	303	40.7	3.8
5	#10480.00	66.0 PK	74.0	-8.0	1.75 H	331	49.4	16.6
6	#10480.00	52.7 AV	54.0	-1.3	1.75 H	331	36.1	16.6

ANTENNA POLARITY & TEST DISTANCE: VERTICAL AT 3 M

NO.	FREQ. (MHz)	EMISSION LEVEL (dBuV/m)	LIMIT (dBuV/m)	MARGIN (dB)	ANTENNA HEIGHT (m)	TABLE ANGLE (Degree)	RAW VALUE (dBuV)	CORRECTION FACTOR (dB/m)
1	*5240.00	111.8 PK			1.74 V	350	72.4	39.4
2	*5240.00	101.7 AV			1.74 V	350	62.3	39.4
3	5350.00	56.3 PK	74.0	-17.7	1.75 V	345	52.5	3.8
4	5350.00	45.4 AV	54.0	-8.6	1.75 V	345	41.6	3.8
5	#10480.00	59.6 PK	74.0	-14.4	1.50 V	283	43.0	16.6
6	#10480.00	46.5 AV	54.0	-7.5	1.50 V	283	29.9	16.6

Remarks:

1. Emission Level(dBuV/m) = Raw Value(dBuV) + Correction Factor(dB/m)
2. Correction Factor(dB/m) = Antenna Factor(dB/m) + Cable Factor(dB) – Pre-Amplifier Factor(dB)
3. The other emission levels were very low against the limit.
4. Margin value = Emission Level – Limit value
5. " * ": Fundamental frequency.
6. " # ": The radiated frequency is out of the restricted band.

CHANNEL	TX Channel 149	DETECTOR FUNCTION	Peak (PK)
FREQUENCY RANGE	1GHz ~ 40GHz		Average (AV)

ANTENNA POLARITY & TEST DISTANCE: HORIZONTAL AT 3 M								
NO.	FREQ. (MHz)	EMISSION LEVEL (dBuV/m)	LIMIT (dBuV/m)	MARGIN (dB)	ANTENNA HEIGHT (m)	TABLE ANGLE (Degree)	RAW VALUE (dBuV)	CORRECTION FACTOR (dB/m)
1	#5604.80	56.5 PK	68.2	-11.7	2.16 H	316	52.3	4.2
2	*5745.00	106.1 PK			2.16 H	316	66.0	40.1
3	*5745.00	96.6 AV			2.16 H	316	56.5	40.1
4	#5982.40	57.4 PK	68.2	-10.8	2.16 H	316	52.4	5.0
5	11490.00	66.2 PK	74.0	-7.8	1.52 H	350	48.4	17.8
6	11490.00	52.8 AV	54.0	-1.2	1.52 H	350	35.0	17.8

ANTENNA POLARITY & TEST DISTANCE: VERTICAL AT 3 M								
NO.	FREQ. (MHz)	EMISSION LEVEL (dBuV/m)	LIMIT (dBuV/m)	MARGIN (dB)	ANTENNA HEIGHT (m)	TABLE ANGLE (Degree)	RAW VALUE (dBuV)	CORRECTION FACTOR (dB/m)
1	#5600.00	57.1 PK	68.2	-11.1	1.87 V	20	52.9	4.2
2	*5745.00	107.7 PK			1.87 V	20	67.6	40.1
3	*5745.00	99.0 AV			1.87 V	20	58.9	40.1
4	#5978.40	58.7 PK	68.2	-9.5	1.87 V	20	53.7	5.0
5	11490.00	61.8 PK	74.0	-12.2	1.82 V	299	44.0	17.8
6	11490.00	48.8 AV	54.0	-5.2	1.82 V	299	31.0	17.8

Remarks:

1. Emission Level(dBuV/m) = Raw Value(dBuV) + Correction Factor(dB/m)
2. Correction Factor(dB/m) = Antenna Factor(dB/m) + Cable Factor(dB) – Pre-Amplifier Factor(dB)
3. The other emission levels were very low against the limit.
4. Margin value = Emission Level – Limit value
5. " * ": Fundamental frequency.
6. " # ": The radiated frequency is out of the restricted band.

CHANNEL	TX Channel 157	DETECTOR FUNCTION	Peak (PK)
FREQUENCY RANGE	1GHz ~ 40GHz		Average (AV)

ANTENNA POLARITY & TEST DISTANCE: HORIZONTAL AT 3 M

NO.	FREQ. (MHz)	EMISSION LEVEL (dBuV/m)	LIMIT (dBuV/m)	MARGIN (dB)	ANTENNA HEIGHT (m)	TABLE ANGLE (Degree)	RAW VALUE (dBuV)	CORRECTION FACTOR (dB/m)
1	#5635.20	56.9 PK	68.2	-11.3	2.13 H	319	52.7	4.2
2	*5785.00	100.6 PK			2.13 H	319	60.3	40.3
3	*5785.00	91.2 AV			2.13 H	319	50.9	40.3
4	#5968.80	58.2 PK	68.2	-10.0	2.13 H	319	53.2	5.0
5	11570.00	66.3 PK	74.0	-7.7	1.51 H	20	48.2	18.1
6	11570.00	52.5 AV	54.0	-1.5	1.51 H	20	34.4	18.1

ANTENNA POLARITY & TEST DISTANCE: VERTICAL AT 3 M

NO.	FREQ. (MHz)	EMISSION LEVEL (dBuV/m)	LIMIT (dBuV/m)	MARGIN (dB)	ANTENNA HEIGHT (m)	TABLE ANGLE (Degree)	RAW VALUE (dBuV)	CORRECTION FACTOR (dB/m)
1	#5632.00	56.5 PK	68.2	-11.7	1.89 V	23	52.3	4.2
2	*5785.00	104.0 PK			2.12 V	17	63.7	40.3
3	*5785.00	94.4 AV			2.12 V	17	54.1	40.3
4	#5929.60	58.3 PK	68.2	-9.9	1.89 V	23	53.3	5.0
5	11570.00	60.8 PK	74.0	-13.2	1.96 V	322	42.7	18.1
6	11570.00	47.5 AV	54.0	-6.5	1.96 V	322	29.4	18.1

Remarks:

1. Emission Level(dBuV/m) = Raw Value(dBuV) + Correction Factor(dB/m)
2. Correction Factor(dB/m) = Antenna Factor(dB/m) + Cable Factor(dB) – Pre-Amplifier Factor(dB)
3. The other emission levels were very low against the limit.
4. Margin value = Emission Level – Limit value
5. " * ": Fundamental frequency.
6. " # ": The radiated frequency is out of the restricted band.

CHANNEL	TX Channel 165	DETECTOR FUNCTION	Peak (PK)
FREQUENCY RANGE	1GHz ~ 40GHz		Average (AV)

ANTENNA POLARITY & TEST DISTANCE: HORIZONTAL AT 3 M								
NO.	FREQ. (MHz)	EMISSION LEVEL (dBuV/m)	LIMIT (dBuV/m)	MARGIN (dB)	ANTENNA HEIGHT (m)	TABLE ANGLE (Degree)	RAW VALUE (dBuV)	CORRECTION FACTOR (dB/m)
1	#5627.20	55.7 PK	68.2	-12.5	2.20 H	320	51.5	4.2
2	*5825.00	100.1 PK			2.21 H	320	59.6	40.5
3	*5825.00	90.8 AV			2.21 H	320	50.3	40.5
4	#5930.40	56.5 PK	68.2	-11.7	2.20 H	320	51.5	5.0
5	11650.00	65.9 PK	74.0	-8.1	1.45 H	19	48.2	17.7
6	11650.00	53.0 AV	54.0	-1.0	1.45 H	19	35.3	17.7
ANTENNA POLARITY & TEST DISTANCE: VERTICAL AT 3 M								
NO.	FREQ. (MHz)	EMISSION LEVEL (dBuV/m)	LIMIT (dBuV/m)	MARGIN (dB)	ANTENNA HEIGHT (m)	TABLE ANGLE (Degree)	RAW VALUE (dBuV)	CORRECTION FACTOR (dB/m)
1	#5633.60	55.7 PK	68.2	-12.5	1.86 V	328	51.5	4.2
2	*5825.00	103.1 PK			1.86 V	328	62.6	40.5
3	*5825.00	94.0 AV			1.86 V	328	53.5	40.5
4	#5930.40	57.6 PK	68.2	-10.6	1.86 V	328	52.6	5.0
5	11650.00	59.9 PK	74.0	-14.1	2.12 V	24	42.2	17.7
6	11650.00	46.9 AV	54.0	-7.1	2.12 V	24	29.2	17.7

Remarks:

1. Emission Level(dBuV/m) = Raw Value(dBuV) + Correction Factor(dB/m)
2. Correction Factor(dB/m) = Antenna Factor(dB/m) + Cable Factor(dB) – Pre-Amplifier Factor(dB)
3. The other emission levels were very low against the limit.
4. Margin value = Emission Level – Limit value
5. " * ": Fundamental frequency.
6. " # ": The radiated frequency is out of the restricted band.

802.11n (HT20)

CHANNEL	TX Channel 36	DETECTOR	Peak (PK)
FREQUENCY RANGE	1GHz ~ 40GHz	FUNCTION	Average (AV)

ANTENNA POLARITY & TEST DISTANCE: HORIZONTAL AT 3 M								
NO.	FREQ. (MHz)	EMISSION LEVEL (dBuV/m)	LIMIT (dBuV/m)	MARGIN (dB)	ANTENNA HEIGHT (m)	TABLE ANGLE (Degree)	RAW VALUE (dBuV)	CORRECTION FACTOR (dB/m)
1	5150.00	61.2 PK	74.0	-12.8	1.75 H	345	57.5	3.7
2	5150.00	47.7 AV	54.0	-6.3	1.75 H	345	44.0	3.7
3	*5180.00	104.3 PK			2.00 H	352	64.7	39.6
4	*5180.00	94.6 AV			2.00 H	352	55.0	39.6
5	#6906.00	57.7 PK	68.2	-10.5	1.68 H	338	48.6	9.1
6	#10360.00	63.8 PK	74.0	-10.2	2.04 H	333	48.2	15.6
7	#10360.00	50.7 AV	54.0	-3.3	2.04 H	333	35.1	15.6
ANTENNA POLARITY & TEST DISTANCE: VERTICAL AT 3 M								
NO.	FREQ. (MHz)	EMISSION LEVEL (dBuV/m)	LIMIT (dBuV/m)	MARGIN (dB)	ANTENNA HEIGHT (m)	TABLE ANGLE (Degree)	RAW VALUE (dBuV)	CORRECTION FACTOR (dB/m)
1	5150.00	66.2 PK	74.0	-7.8	2.00 V	332	62.5	3.7
2	5150.00	52.1 AV	54.0	-1.9	2.00 V	332	48.4	3.7
3	*5180.00	109.9 PK			1.75 V	352	70.3	39.6
4	*5180.00	100.0 AV			1.75 V	352	60.4	39.6
5	#6906.00	58.1 PK	68.2	-10.1	1.69 V	359	49.0	9.1
6	#10360.00	58.3 PK	74.0	-15.7	1.58 V	282	42.7	15.6
7	#10360.00	45.2 AV	54.0	-8.8	1.58 V	282	29.6	15.6

Remarks:

1. Emission Level(dBuV/m) = Raw Value(dBuV) + Correction Factor(dB/m)
2. Correction Factor(dB/m) = Antenna Factor(dB/m) + Cable Factor(dB) – Pre-Amplifier Factor(dB)
3. The other emission levels were very low against the limit.
4. Margin value = Emission Level – Limit value
5. " * ": Fundamental frequency.
6. " # ": The radiated frequency is out of the restricted band.

CHANNEL	TX Channel 40	DETECTOR	Peak (PK)
FREQUENCY RANGE	1GHz ~ 40GHz	FUNCTION	Average (AV)

ANTENNA POLARITY & TEST DISTANCE: HORIZONTAL AT 3 M

NO.	FREQ. (MHz)	EMISSION LEVEL (dBuV/m)	LIMIT (dBuV/m)	MARGIN (dB)	ANTENNA HEIGHT (m)	TABLE ANGLE (Degree)	RAW VALUE (dBuV)	CORRECTION FACTOR (dB/m)
1	*5200.00	106.1 PK			1.72 H	339	66.5	39.6
2	*5200.00	96.1 AV			1.72 H	339	56.5	39.6
3	#6933.00	55.8 PK	68.2	-12.4	1.34 H	340	46.5	9.3
4	#10400.00	65.1 PK	74.0	-8.9	2.16 H	333	49.5	15.6
5	#10400.00	50.9 AV	54.0	-3.1	2.16 H	333	35.3	15.6

ANTENNA POLARITY & TEST DISTANCE: VERTICAL AT 3 M

NO.	FREQ. (MHz)	EMISSION LEVEL (dBuV/m)	LIMIT (dBuV/m)	MARGIN (dB)	ANTENNA HEIGHT (m)	TABLE ANGLE (Degree)	RAW VALUE (dBuV)	CORRECTION FACTOR (dB/m)
1	*5200.00	110.8 PK			1.87 V	355	71.2	39.6
2	*5200.00	100.7 AV			1.87 V	355	61.1	39.6
3	#6933.00	56.8 PK	68.2	-11.4	1.68 V	358	47.5	9.3
4	#10400.00	58.2 PK	74.0	-15.8	1.76 V	290	42.6	15.6
5	#10400.00	45.1 AV	54.0	-8.9	1.76 V	290	29.5	15.6

Remarks:

1. Emission Level(dBuV/m) = Raw Value(dBuV) + Correction Factor(dB/m)
2. Correction Factor(dB/m) = Antenna Factor(dB/m) + Cable Factor(dB) – Pre-Amplifier Factor(dB)
3. The other emission levels were very low against the limit.
4. Margin value = Emission Level – Limit value
5. " * ": Fundamental frequency.
6. " # ": The radiated frequency is out of the restricted band.

CHANNEL	TX Channel 48	DETECTOR FUNCTION	Peak (PK)
FREQUENCY RANGE	1GHz ~ 40GHz		Average (AV)

ANTENNA POLARITY & TEST DISTANCE: HORIZONTAL AT 3 M

NO.	FREQ. (MHz)	EMISSION LEVEL (dBuV/m)	LIMIT (dBuV/m)	MARGIN (dB)	ANTENNA HEIGHT (m)	TABLE ANGLE (Degree)	RAW VALUE (dBuV)	CORRECTION FACTOR (dB/m)
1	*5240.00	105.8 PK			1.88 H	13	66.4	39.4
2	*5240.00	95.9 AV			1.88 H	13	56.5	39.4
3	5350.00	55.6 PK	74.0	-18.4	1.88 H	20	51.8	3.8
4	5350.00	44.4 AV	54.0	-9.6	1.88 H	20	40.6	3.8
5	#10480.00	64.8 PK	74.0	-9.2	1.92 H	330	48.2	16.6
6	#10480.00	52.2 AV	54.0	-1.8	1.92 H	330	35.6	16.6

ANTENNA POLARITY & TEST DISTANCE: VERTICAL AT 3 M

NO.	FREQ. (MHz)	EMISSION LEVEL (dBuV/m)	LIMIT (dBuV/m)	MARGIN (dB)	ANTENNA HEIGHT (m)	TABLE ANGLE (Degree)	RAW VALUE (dBuV)	CORRECTION FACTOR (dB/m)
1	*5240.00	112.0 PK			1.62 V	348	72.6	39.4
2	*5240.00	102.2 AV			1.62 V	348	62.8	39.4
3	5350.00	56.2 PK	74.0	-17.8	1.70 V	300	52.4	3.8
4	5350.00	44.9 AV	54.0	-9.1	1.70 V	300	41.1	3.8
5	#10480.00	59.5 PK	74.0	-14.5	1.67 V	276	42.9	16.6
6	#10480.00	46.4 AV	54.0	-7.6	1.67 V	276	29.8	16.6

Remarks:

1. Emission Level(dBuV/m) = Raw Value(dBuV) + Correction Factor(dB/m)
2. Correction Factor(dB/m) = Antenna Factor(dB/m) + Cable Factor(dB) – Pre-Amplifier Factor(dB)
3. The other emission levels were very low against the limit.
4. Margin value = Emission Level – Limit value
5. " * ": Fundamental frequency.
6. " # ": The radiated frequency is out of the restricted band.

CHANNEL	TX Channel 149	DETECTOR FUNCTION	Peak (PK)
FREQUENCY RANGE	1GHz ~ 40GHz		Average (AV)

ANTENNA POLARITY & TEST DISTANCE: HORIZONTAL AT 3 M								
NO.	FREQ. (MHz)	EMISSION LEVEL (dBuV/m)	LIMIT (dBuV/m)	MARGIN (dB)	ANTENNA HEIGHT (m)	TABLE ANGLE (Degree)	RAW VALUE (dBuV)	CORRECTION FACTOR (dB/m)
1	#5621.60	56.5 PK	68.2	-11.7	2.17 H	318	52.3	4.2
2	*5745.00	105.3 PK			2.17 H	318	65.2	40.1
3	*5745.00	95.5 AV			2.17 H	318	55.4	40.1
4	#5947.20	57.4 PK	68.2	-10.8	2.17 H	318	52.4	5.0
5	11490.00	66.5 PK	74.0	-7.5	1.75 H	352	48.7	17.8
6	11490.00	52.7 AV	54.0	-1.3	1.75 H	352	34.9	17.8

ANTENNA POLARITY & TEST DISTANCE: VERTICAL AT 3 M								
NO.	FREQ. (MHz)	EMISSION LEVEL (dBuV/m)	LIMIT (dBuV/m)	MARGIN (dB)	ANTENNA HEIGHT (m)	TABLE ANGLE (Degree)	RAW VALUE (dBuV)	CORRECTION FACTOR (dB/m)
1	#5639.20	55.1 PK	68.2	-13.1	1.90 V	18	50.9	4.2
2	*5745.00	107.7 PK			1.90 V	18	67.6	40.1
3	*5745.00	98.0 AV			1.90 V	18	57.9	40.1
4	#5976.00	56.0 PK	68.2	-12.2	1.90 V	18	51.0	5.0
5	11490.00	60.3 PK	74.0	-13.7	1.99 V	279	42.5	17.8
6	11490.00	48.5 AV	54.0	-5.5	1.99 V	279	30.7	17.8

Remarks:

1. Emission Level(dBuV/m) = Raw Value(dBuV) + Correction Factor(dB/m)
2. Correction Factor(dB/m) = Antenna Factor(dB/m) + Cable Factor(dB) – Pre-Amplifier Factor(dB)
3. The other emission levels were very low against the limit.
4. Margin value = Emission Level – Limit value
5. " * ": Fundamental frequency.
6. " # ": The radiated frequency is out of the restricted band.

CHANNEL	TX Channel 157	DETECTOR FUNCTION	Peak (PK)
FREQUENCY RANGE	1GHz ~ 40GHz		Average (AV)

ANTENNA POLARITY & TEST DISTANCE: HORIZONTAL AT 3 M

NO.	FREQ. (MHz)	EMISSION LEVEL (dBuV/m)	LIMIT (dBuV/m)	MARGIN (dB)	ANTENNA HEIGHT (m)	TABLE ANGLE (Degree)	RAW VALUE (dBuV)	CORRECTION FACTOR (dB/m)
1	#5625.60	55.5 PK	68.2	-12.7	2.21 H	314	51.3	4.2
2	*5785.00	102.8 PK			2.21 H	314	62.5	40.3
3	*5785.00	92.9 AV			2.21 H	314	52.6	40.3
4	#5956.00	57.1 PK	68.2	-11.1	2.21 H	314	52.1	5.0
5	11570.00	66.9 PK	74.0	-7.1	1.41 H	19	48.8	18.1
6	11570.00	52.8 AV	54.0	-1.2	1.41 H	19	34.7	18.1

ANTENNA POLARITY & TEST DISTANCE: VERTICAL AT 3 M

NO.	FREQ. (MHz)	EMISSION LEVEL (dBuV/m)	LIMIT (dBuV/m)	MARGIN (dB)	ANTENNA HEIGHT (m)	TABLE ANGLE (Degree)	RAW VALUE (dBuV)	CORRECTION FACTOR (dB/m)
1	#5648.00	55.9 PK	68.2	-12.3	1.79 V	359	51.6	4.3
2	*5785.00	104.1 PK			1.77 V	359	63.8	40.3
3	*5785.00	94.1 AV			1.77 V	359	53.8	40.3
4	#5960.80	57.1 PK	68.2	-11.1	1.79 V	359	52.1	5.0
5	11570.00	61.8 PK	74.0	-12.2	1.91 V	302	43.7	18.1
6	11570.00	48.8 AV	54.0	-5.2	1.91 V	302	30.7	18.1

Remarks:

1. Emission Level(dBuV/m) = Raw Value(dBuV) + Correction Factor(dB/m)
2. Correction Factor(dB/m) = Antenna Factor(dB/m) + Cable Factor(dB) – Pre-Amplifier Factor(dB)
3. The other emission levels were very low against the limit.
4. Margin value = Emission Level – Limit value
5. " * ": Fundamental frequency.
6. " # ": The radiated frequency is out of the restricted band.

CHANNEL	TX Channel 165	DETECTOR FUNCTION	Peak (PK)
FREQUENCY RANGE	1GHz ~ 40GHz		Average (AV)

ANTENNA POLARITY & TEST DISTANCE: HORIZONTAL AT 3 M								
NO.	FREQ. (MHz)	EMISSION LEVEL (dBuV/m)	LIMIT (dBuV/m)	MARGIN (dB)	ANTENNA HEIGHT (m)	TABLE ANGLE (Degree)	RAW VALUE (dBuV)	CORRECTION FACTOR (dB/m)
1	#5623.20	55.9 PK	68.2	-12.3	2.13 H	315	51.7	4.2
2	*5825.00	100.8 PK			2.13 H	315	60.3	40.5
3	*5825.00	91.0 AV			2.13 H	315	50.5	40.5
4	#5948.00	57.0 PK	68.2	-11.2	2.13 H	315	52.0	5.0
5	11650.00	66.8 PK	74.0	-7.2	1.41 H	20	49.1	17.7
6	11650.00	53.0 AV	54.0	-1.0	1.41 H	20	35.3	17.7

ANTENNA POLARITY & TEST DISTANCE: VERTICAL AT 3 M								
NO.	FREQ. (MHz)	EMISSION LEVEL (dBuV/m)	LIMIT (dBuV/m)	MARGIN (dB)	ANTENNA HEIGHT (m)	TABLE ANGLE (Degree)	RAW VALUE (dBuV)	CORRECTION FACTOR (dB/m)
1	#5629.60	55.4 PK	68.2	-12.8	1.77 V	3	51.2	4.2
2	*5825.00	103.6 PK			1.77 V	3	63.1	40.5
3	*5825.00	94.2 AV			1.77 V	3	53.7	40.5
4	#5958.40	56.8 PK	68.2	-11.4	1.77 V	3	51.8	5.0
5	11650.00	61.0 PK	74.0	-13.0	1.80 V	298	43.3	17.7
6	11650.00	48.2 AV	54.0	-5.8	1.80 V	298	30.5	17.7

Remarks:

1. Emission Level(dBuV/m) = Raw Value(dBuV) + Correction Factor(dB/m)
2. Correction Factor(dB/m) = Antenna Factor(dB/m) + Cable Factor(dB) – Pre-Amplifier Factor(dB)
3. The other emission levels were very low against the limit.
4. Margin value = Emission Level – Limit value
5. " * ": Fundamental frequency.
6. " # ": The radiated frequency is out of the restricted band.

802.11n (HT40)

CHANNEL	TX Channel 38	DETECTOR	Peak (PK)
FREQUENCY RANGE	1GHz ~ 40GHz	FUNCTION	Average (AV)

ANTENNA POLARITY & TEST DISTANCE: HORIZONTAL AT 3 M								
NO.	FREQ. (MHz)	EMISSION LEVEL (dBuV/m)	LIMIT (dBuV/m)	MARGIN (dB)	ANTENNA HEIGHT (m)	TABLE ANGLE (Degree)	RAW VALUE (dBuV)	CORRECTION FACTOR (dB/m)
1	5150.00	60.4 PK	74.0	-13.6	1.58 H	346	56.7	3.7
2	5150.00	48.3 AV	54.0	-5.7	1.58 H	346	44.6	3.7
3	*5190.00	97.2 PK			1.74 H	333	57.6	39.6
4	*5190.00	88.1 AV			1.74 H	333	48.5	39.6
5	#10380.00	59.6 PK	74.0	-14.4	1.89 H	321	44.0	15.6
6	#10380.00	47.4 AV	54.0	-6.6	1.89 H	321	31.8	15.6
ANTENNA POLARITY & TEST DISTANCE: VERTICAL AT 3 M								
NO.	FREQ. (MHz)	EMISSION LEVEL (dBuV/m)	LIMIT (dBuV/m)	MARGIN (dB)	ANTENNA HEIGHT (m)	TABLE ANGLE (Degree)	RAW VALUE (dBuV)	CORRECTION FACTOR (dB/m)
1	5150.00	66.0 PK	74.0	-8.0	2.09 V	333	62.3	3.7
2	5150.00	52.7 AV	54.0	-1.3	2.09 V	333	49.0	3.7
3	*5190.00	102.9 PK			1.57 V	349	63.3	39.6
4	*5190.00	93.9 AV			1.57 V	349	54.3	39.6
5	#10380.00	58.1 PK	74.0	-15.9	1.50 V	290	42.5	15.6
6	#10380.00	45.1 AV	54.0	-8.9	1.50 V	290	29.5	15.6

Remarks:

1. Emission Level(dBuV/m) = Raw Value(dBuV) + Correction Factor(dB/m)
2. Correction Factor(dB/m) = Antenna Factor(dB/m) + Cable Factor(dB) – Pre-Amplifier Factor(dB)
3. The other emission levels were very low against the limit.
4. Margin value = Emission Level – Limit value
5. " * ": Fundamental frequency.
6. " # ": The radiated frequency is out of the restricted band.

CHANNEL	TX Channel 46	DETECTOR FUNCTION	Peak (PK)
FREQUENCY RANGE	1GHz ~ 40GHz		Average (AV)

ANTENNA POLARITY & TEST DISTANCE: HORIZONTAL AT 3 M

NO.	FREQ. (MHz)	EMISSION LEVEL (dBuV/m)	LIMIT (dBuV/m)	MARGIN (dB)	ANTENNA HEIGHT (m)	TABLE ANGLE (Degree)	RAW VALUE (dBuV)	CORRECTION FACTOR (dB/m)
1	*5230.00	102.1 PK			1.65 H	338	62.7	39.4
2	*5230.00	92.9 AV			1.65 H	338	53.5	39.4
3	5350.00	58.3 PK	74.0	-15.7	1.66 H	304	54.5	3.8
4	5350.00	46.3 AV	54.0	-7.7	1.66 H	304	42.5	3.8
5	#10460.00	62.5 PK	74.0	-11.5	1.85 H	333	46.3	16.2
6	#10460.00	50.3 AV	54.0	-3.7	1.85 H	333	34.1	16.2

ANTENNA POLARITY & TEST DISTANCE: VERTICAL AT 3 M

NO.	FREQ. (MHz)	EMISSION LEVEL (dBuV/m)	LIMIT (dBuV/m)	MARGIN (dB)	ANTENNA HEIGHT (m)	TABLE ANGLE (Degree)	RAW VALUE (dBuV)	CORRECTION FACTOR (dB/m)
1	*5230.00	108.3 PK			1.70 V	352	68.9	39.4
2	*5230.00	98.7 AV			1.70 V	352	59.3	39.4
3	5350.00	57.9 PK	74.0	-16.1	1.60 V	22	54.1	3.8
4	5350.00	45.9 AV	54.0	-8.1	1.60 V	22	42.1	3.8
5	#10460.00	58.5 PK	74.0	-15.5	1.38 V	264	42.3	16.2
6	#10460.00	45.5 AV	54.0	-8.5	1.38 V	264	29.3	16.2

Remarks:

1. Emission Level(dBuV/m) = Raw Value(dBuV) + Correction Factor(dB/m)
2. Correction Factor(dB/m) = Antenna Factor(dB/m) + Cable Factor(dB) – Pre-Amplifier Factor(dB)
3. The other emission levels were very low against the limit.
4. Margin value = Emission Level – Limit value
5. " * ": Fundamental frequency.
6. " # ": The radiated frequency is out of the restricted band.

CHANNEL	TX Channel 151	DETECTOR FUNCTION	Peak (PK)
FREQUENCY RANGE	1GHz ~ 40GHz		Average (AV)

ANTENNA POLARITY & TEST DISTANCE: HORIZONTAL AT 3 M								
NO.	FREQ. (MHz)	EMISSION LEVEL (dBuV/m)	LIMIT (dBuV/m)	MARGIN (dB)	ANTENNA HEIGHT (m)	TABLE ANGLE (Degree)	RAW VALUE (dBuV)	CORRECTION FACTOR (dB/m)
1	#5648.80	56.3 PK	68.2	-11.9	2.78 H	11	52.0	4.3
2	*5755.00	104.4 PK			2.78 H	11	64.3	40.1
3	*5755.00	95.1 AV			2.78 H	11	55.0	40.1
4	#5924.80	57.3 PK	68.3	-11.0	2.78 H	11	52.4	4.9
5	11510.00	65.8 PK	74.0	-8.2	1.40 H	21	48.0	17.8
6	11510.00	52.6 AV	54.0	-1.4	1.40 H	21	34.8	17.8

ANTENNA POLARITY & TEST DISTANCE: VERTICAL AT 3 M								
NO.	FREQ. (MHz)	EMISSION LEVEL (dBuV/m)	LIMIT (dBuV/m)	MARGIN (dB)	ANTENNA HEIGHT (m)	TABLE ANGLE (Degree)	RAW VALUE (dBuV)	CORRECTION FACTOR (dB/m)
1	#5629.60	56.1 PK	68.2	-12.1	1.50 V	322	51.9	4.2
2	*5755.00	106.6 PK			1.50 V	322	66.5	40.1
3	*5755.00	97.6 AV			1.50 V	322	57.5	40.1
4	#5961.60	57.6 PK	68.2	-10.6	1.50 V	322	52.6	5.0
5	11510.00	60.5 PK	74.0	-13.5	2.02 V	295	42.7	17.8
6	11510.00	47.4 AV	54.0	-6.6	2.02 V	295	29.6	17.8

Remarks:

1. Emission Level(dBuV/m) = Raw Value(dBuV) + Correction Factor(dB/m)
2. Correction Factor(dB/m) = Antenna Factor(dB/m) + Cable Factor(dB) – Pre-Amplifier Factor(dB)
3. The other emission levels were very low against the limit.
4. Margin value = Emission Level – Limit value
5. " * ": Fundamental frequency.
6. " # ": The radiated frequency is out of the restricted band.

CHANNEL	TX Channel 159	DETECTOR FUNCTION	Peak (PK)
FREQUENCY RANGE	1GHz ~ 40GHz		Average (AV)

ANTENNA POLARITY & TEST DISTANCE: HORIZONTAL AT 3 M								
NO.	FREQ. (MHz)	EMISSION LEVEL (dBuV/m)	LIMIT (dBuV/m)	MARGIN (dB)	ANTENNA HEIGHT (m)	TABLE ANGLE (Degree)	RAW VALUE (dBuV)	CORRECTION FACTOR (dB/m)
1	#5636.00	56.0 PK	68.2	-12.2	2.70 H	10	51.8	4.2
2	*5795.00	102.4 PK			2.70 H	10	62.1	40.3
3	*5795.00	93.0 AV			2.70 H	10	52.7	40.3
4	#5945.60	57.8 PK	68.2	-10.4	2.70 H	10	52.8	5.0
5	11590.00	65.6 PK	74.0	-8.4	1.39 H	352	47.6	18.0
6	11590.00	52.9 AV	54.0	-1.1	1.39 H	352	34.9	18.0

ANTENNA POLARITY & TEST DISTANCE: VERTICAL AT 3 M								
NO.	FREQ. (MHz)	EMISSION LEVEL (dBuV/m)	LIMIT (dBuV/m)	MARGIN (dB)	ANTENNA HEIGHT (m)	TABLE ANGLE (Degree)	RAW VALUE (dBuV)	CORRECTION FACTOR (dB/m)
1	#5618.40	55.5 PK	68.2	-12.7	1.57 V	319	51.3	4.2
2	*5795.00	103.2 PK			1.57 V	319	62.9	40.3
3	*5795.00	94.0 AV			1.57 V	319	53.7	40.3
4	#5938.40	57.2 PK	68.2	-11.0	1.57 V	319	52.3	4.9
5	11590.00	60.2 PK	74.0	-13.8	2.07 V	295	42.2	18.0
6	11590.00	47.1 AV	54.0	-6.9	2.07 V	295	29.1	18.0

Remarks:

1. Emission Level(dBuV/m) = Raw Value(dBuV) + Correction Factor(dB/m)
2. Correction Factor(dB/m) = Antenna Factor(dB/m) + Cable Factor(dB) – Pre-Amplifier Factor(dB)
3. The other emission levels were very low against the limit.
4. Margin value = Emission Level – Limit value
5. " * ": Fundamental frequency.
6. " # ": The radiated frequency is out of the restricted band.

802.11ac (VHT80)

CHANNEL	TX Channel 42	DETECTOR FUNCTION	Peak (PK)
FREQUENCY RANGE	1GHz ~ 40GHz		Average (AV)

ANTENNA POLARITY & TEST DISTANCE: HORIZONTAL AT 3 M

NO.	FREQ. (MHz)	EMISSION LEVEL (dBuV/m)	LIMIT (dBuV/m)	MARGIN (dB)	ANTENNA HEIGHT (m)	TABLE ANGLE (Degree)	RAW VALUE (dBuV)	CORRECTION FACTOR (dB/m)
1	5150.00	61.6 PK	74.0	-12.4	1.89 H	6	57.9	3.7
2	5150.00	48.8 AV	54.0	-5.2	1.89 H	6	45.1	3.7
3	*5210.00	93.3 PK			1.63 H	340	53.8	39.5
4	*5210.00	82.2 AV			1.63 H	340	42.7	39.5
5	5350.00	55.8 PK	74.0	-18.2	1.77 H	356	52.0	3.8
6	5350.00	45.1 AV	54.0	-8.9	1.77 H	356	41.3	3.8
7	#10420.00	58.1 PK	74.0	-15.9	2.00 H	328	42.3	15.8
8	#10420.00	45.4 AV	54.0	-8.6	2.00 H	328	29.6	15.8

ANTENNA POLARITY & TEST DISTANCE: VERTICAL AT 3 M

NO.	FREQ. (MHz)	EMISSION LEVEL (dBuV/m)	LIMIT (dBuV/m)	MARGIN (dB)	ANTENNA HEIGHT (m)	TABLE ANGLE (Degree)	RAW VALUE (dBuV)	CORRECTION FACTOR (dB/m)
1	5150.00	66.1 PK	74.0	-7.9	2.25 V	336	62.4	3.7
2	5150.00	53.0 AV	54.0	-1.0	2.25 V	336	49.3	3.7
3	*5210.00	99.6 PK			1.63 V	346	60.1	39.5
4	*5210.00	88.5 AV			1.63 V	346	49.0	39.5
5	5350.00	56.1 PK	74.0	-17.9	2.11 V	355	52.3	3.8
6	5350.00	44.6 AV	54.0	-9.4	2.11 V	355	40.8	3.8
7	#10420.00	57.9 PK	74.0	-16.1	1.58 V	250	42.1	15.8
8	#10420.00	44.8 AV	54.0	-9.2	1.58 V	250	29.0	15.8

Remarks:

1. Emission Level(dBuV/m) = Raw Value(dBuV) + Correction Factor(dB/m)
2. Correction Factor(dB/m) = Antenna Factor(dB/m) + Cable Factor(dB) – Pre-Amplifier Factor(dB)
3. The other emission levels were very low against the limit.
4. Margin value = Emission Level – Limit value
5. " * ": Fundamental frequency.
6. " # ": The radiated frequency is out of the restricted band.

CHANNEL	TX Channel 155	DETECTOR FUNCTION	Peak (PK)
FREQUENCY RANGE	1GHz ~ 40GHz		Average (AV)

ANTENNA POLARITY & TEST DISTANCE: HORIZONTAL AT 3 M								
NO.	FREQ. (MHz)	EMISSION LEVEL (dBuV/m)	LIMIT (dBuV/m)	MARGIN (dB)	ANTENNA HEIGHT (m)	TABLE ANGLE (Degree)	RAW VALUE (dBuV)	CORRECTION FACTOR (dB/m)
1	#5641.60	59.5 PK	68.2	-8.7	2.81 H	7	55.3	4.2
2	#5650.00	60.9 PK	68.2	-7.3	2.79 H	335	56.6	4.3
3	*5775.00	104.5 PK			2.81 H	7	64.3	40.2
4	*5775.00	92.5 AV			2.81 H	7	52.3	40.2
5	#5925.00	60.2 PK	68.2	-8.0	2.79 H	335	55.3	4.9
6	#5927.20	57.4 PK	68.2	-10.8	2.81 H	7	52.5	4.9
7	11550.00	66.0 PK	74.0	-8.0	1.40 H	18	48.0	18.0
8	11550.00	52.3 AV	54.0	-1.7	1.40 H	18	34.3	18.0

ANTENNA POLARITY & TEST DISTANCE: VERTICAL AT 3 M								
NO.	FREQ. (MHz)	EMISSION LEVEL (dBuV/m)	LIMIT (dBuV/m)	MARGIN (dB)	ANTENNA HEIGHT (m)	TABLE ANGLE (Degree)	RAW VALUE (dBuV)	CORRECTION FACTOR (dB/m)
1	#5648.00	60.9 PK	68.2	-7.3	1.48 V	321	56.6	4.3
2	#5650.00	62.6 PK	68.2	-5.6	2.50 V	22	58.3	4.3
3	*5775.00	105.7 PK			1.48 V	321	65.5	40.2
4	*5775.00	93.9 AV			1.48 V	321	53.7	40.2
5	#5925.00	59.0 PK	68.2	-9.2	2.50 V	21	54.1	4.9
6	#5953.60	57.2 PK	68.2	-11.0	1.48 V	321	52.2	5.0
7	11550.00	60.1 PK	74.0	-13.9	2.41 V	280	42.1	18.0
8	11550.00	47.0 AV	54.0	-7.0	2.41 V	280	29.0	18.0

Remarks:

1. Emission Level(dBuV/m) = Raw Value(dBuV) + Correction Factor(dB/m)
2. Correction Factor(dB/m) = Antenna Factor(dB/m) + Cable Factor(dB) – Pre-Amplifier Factor(dB)
3. The other emission levels were very low against the limit.
4. Margin value = Emission Level – Limit value
5. " * ": Fundamental frequency.
6. " # ": The radiated frequency is out of the restricted band.

Below 1GHz Worst-Case Data: 802.11a

CHANNEL	TX Channel 165	DETECTOR FUNCTION	Quasi-Peak (QP)
FREQUENCY RANGE	9kHz ~ 1GHz		
TEST MODE	A		

ANTENNA POLARITY & TEST DISTANCE: HORIZONTAL AT 3 M

NO.	FREQ. (MHz)	EMISSION LEVEL (dBuV/m)	LIMIT (dBuV/m)	MARGIN (dB)	ANTENNA HEIGHT (m)	TABLE ANGLE (Degree)	RAW VALUE (dBuV)	CORRECTION FACTOR (dB/m)
1	57.12	24.7 QP	40.0	-15.3	1.00 H	315	39.1	-14.4
2	162.11	30.1 QP	43.5	-13.4	1.00 H	234	44.0	-13.9
3	333.21	34.3 QP	46.0	-11.7	1.00 H	217	46.4	-12.1
4	539.30	24.5 QP	46.0	-21.5	1.50 H	203	33.6	-9.1
5	729.84	31.9 QP	46.0	-14.1	1.00 H	16	37.1	-5.2
6	937.88	33.2 QP	46.0	-12.8	1.99 H	16	35.2	-2.0

ANTENNA POLARITY & TEST DISTANCE: VERTICAL AT 3 M

NO.	FREQ. (MHz)	EMISSION LEVEL (dBuV/m)	LIMIT (dBuV/m)	MARGIN (dB)	ANTENNA HEIGHT (m)	TABLE ANGLE (Degree)	RAW VALUE (dBuV)	CORRECTION FACTOR (dB/m)
1	94.06	35.4 QP	43.5	-8.1	1.00 V	125	54.6	-19.2
2	171.83	27.2 QP	43.5	-16.3	1.00 V	151	41.5	-14.3
3	333.21	28.7 QP	46.0	-17.3	1.99 V	136	40.8	-12.1
4	547.08	25.8 QP	46.0	-20.2	1.00 V	307	34.5	-8.7
5	640.41	29.7 QP	46.0	-16.3	1.99 V	86	36.3	-6.6
6	939.83	32.4 QP	46.0	-13.6	1.00 V	8	34.4	-2.0

Remarks:

1. Emission Level(dBuV/m) = Raw Value(dBuV) + Correction Factor(dB/m)
2. Correction Factor(dB/m) = Antenna Factor(dB/m) + Cable Factor(dB) – Pre-Amplifier Factor(dB)
3. The other emission levels were very low against the limit.
4. Margin value = Emission Level – Limit value

CHANNEL	TX Channel 165	DETECTOR FUNCTION	Quasi-Peak (QP)
FREQUENCY RANGE	9kHz ~ 1GHz		
TEST MODE	B		

ANTENNA POLARITY & TEST DISTANCE: HORIZONTAL AT 3 M

NO.	FREQ. (MHz)	EMISSION LEVEL (dBuV/m)	LIMIT (dBuV/m)	MARGIN (dB)	ANTENNA HEIGHT (m)	TABLE ANGLE (Degree)	RAW VALUE (dBuV)	CORRECTION FACTOR (dB/m)
1	70.73	24.4 QP	40.0	-15.6	1.00 H	113	40.6	-16.2
2	138.78	25.3 QP	43.5	-18.2	1.00 H	243	40.0	-14.7
3	249.60	23.3 QP	46.0	-22.7	1.00 H	250	37.9	-14.6
4	346.82	27.0 QP	46.0	-19.0	1.50 H	37	39.2	-12.2
5	568.47	26.2 QP	46.0	-19.8	1.00 H	347	34.5	-8.3
6	840.67	27.4 QP	46.0	-18.6	1.99 H	90	30.9	-3.5

ANTENNA POLARITY & TEST DISTANCE: VERTICAL AT 3 M

NO.	FREQ. (MHz)	EMISSION LEVEL (dBuV/m)	LIMIT (dBuV/m)	MARGIN (dB)	ANTENNA HEIGHT (m)	TABLE ANGLE (Degree)	RAW VALUE (dBuV)	CORRECTION FACTOR (dB/m)
1	55.18	36.2 QP	40.0	-3.8	1.50 V	18	50.5	-14.3
2	189.33	26.6 QP	43.5	-16.9	1.00 V	232	42.8	-16.2
3	313.77	24.1 QP	46.0	-21.9	1.99 V	178	36.5	-12.4
4	556.80	26.0 QP	46.0	-20.0	1.00 V	6	34.5	-8.5
5	729.84	39.9 QP	46.0	-6.1	1.99 V	6	45.1	-5.2
6	935.94	36.7 QP	46.0	-9.3	1.00 V	219	38.8	-2.1

Remarks:

1. Emission Level(dBuV/m) = Raw Value(dBuV) + Correction Factor(dB/m)
2. Correction Factor(dB/m) = Antenna Factor(dB/m) + Cable Factor(dB) – Pre-Amplifier Factor(dB)
3. The other emission levels were very low against the limit.
4. Margin value = Emission Level – Limit value

CHANNEL	TX Channel 165	DETECTOR FUNCTION	Quasi-Peak (QP)
FREQUENCY RANGE	9kHz ~ 1GHz		
TEST MODE	C		

ANTENNA POLARITY & TEST DISTANCE: HORIZONTAL AT 3 M

NO.	FREQ. (MHz)	EMISSION LEVEL (dBuV/m)	LIMIT (dBuV/m)	MARGIN (dB)	ANTENNA HEIGHT (m)	TABLE ANGLE (Degree)	RAW VALUE (dBuV)	CORRECTION FACTOR (dB/m)
1	57.12	24.2 QP	40.0	-15.8	1.99 H	68	38.6	-14.4
2	173.78	24.6 QP	43.5	-18.9	1.50 H	265	39.1	-14.5
3	313.77	30.5 QP	46.0	-15.5	1.00 H	134	42.9	-12.4
4	414.87	26.4 QP	46.0	-19.6	1.50 H	302	37.4	-11.0
5	541.25	27.3 QP	46.0	-18.7	1.00 H	168	36.1	-8.8
6	939.83	33.3 QP	46.0	-12.7	1.99 H	5	35.3	-2.0

ANTENNA POLARITY & TEST DISTANCE: VERTICAL AT 3 M

NO.	FREQ. (MHz)	EMISSION LEVEL (dBuV/m)	LIMIT (dBuV/m)	MARGIN (dB)	ANTENNA HEIGHT (m)	TABLE ANGLE (Degree)	RAW VALUE (dBuV)	CORRECTION FACTOR (dB/m)
1	51.29	32.8 QP	40.0	-7.2	1.00 V	300	46.9	-14.1
2	94.06	32.9 QP	43.5	-10.6	1.00 V	148	52.1	-19.2
3	160.17	28.9 QP	43.5	-14.6	1.00 V	192	42.7	-13.8
4	329.32	29.5 QP	46.0	-16.5	1.00 V	159	41.6	-12.1
5	541.25	30.6 QP	46.0	-15.4	1.00 V	168	39.4	-8.8
6	932.05	31.6 QP	46.0	-14.4	1.00 V	303	33.6	-2.0

Remarks:

1. Emission Level(dBuV/m) = Raw Value(dBuV) + Correction Factor(dB/m)
2. Correction Factor(dB/m) = Antenna Factor(dB/m) + Cable Factor(dB) – Pre-Amplifier Factor(dB)
3. The other emission levels were very low against the limit.
4. Margin value = Emission Level – Limit value

CHANNEL	TX Channel 165	DETECTOR FUNCTION	Quasi-Peak (QP)
FREQUENCY RANGE	9kHz ~ 1GHz		
TEST MODE	D		

ANTENNA POLARITY & TEST DISTANCE: HORIZONTAL AT 3 M

NO.	FREQ. (MHz)	EMISSION LEVEL (dBuV/m)	LIMIT (dBuV/m)	MARGIN (dB)	ANTENNA HEIGHT (m)	TABLE ANGLE (Degree)	RAW VALUE (dBuV)	CORRECTION FACTOR (dB/m)
1	39.62	26.4 QP	40.0	-13.6	1.99 H	97	41.4	-15.0
2	150.45	25.1 QP	43.5	-18.4	1.00 H	99	38.8	-13.7
3	189.33	26.7 QP	43.5	-16.8	1.00 H	259	42.9	-16.2
4	329.32	27.6 QP	46.0	-18.4	1.99 H	113	39.7	-12.1
5	568.47	26.4 QP	46.0	-19.6	1.00 H	136	34.7	-8.3
6	900.94	36.5 QP	46.0	-9.5	1.50 H	19	39.2	-2.7

ANTENNA POLARITY & TEST DISTANCE: VERTICAL AT 3 M

NO.	FREQ. (MHz)	EMISSION LEVEL (dBuV/m)	LIMIT (dBuV/m)	MARGIN (dB)	ANTENNA HEIGHT (m)	TABLE ANGLE (Degree)	RAW VALUE (dBuV)	CORRECTION FACTOR (dB/m)
1	53.23	36.4 QP	40.0	-3.6	1.00 V	350	50.6	-14.2
2	179.61	26.1 QP	43.5	-17.4	1.00 V	60	41.1	-15.0
3	251.55	26.9 QP	46.0	-19.1	1.50 V	222	41.4	-14.5
4	333.21	27.9 QP	46.0	-18.1	1.00 V	168	40.0	-12.1
5	554.86	30.4 QP	46.0	-15.6	1.99 V	63	39.0	-8.6
6	937.88	36.3 QP	46.0	-9.7	1.00 V	94	38.3	-2.0

Remarks:

1. Emission Level(dBuV/m) = Raw Value(dBuV) + Correction Factor(dB/m)
2. Correction Factor(dB/m) = Antenna Factor(dB/m) + Cable Factor(dB) – Pre-Amplifier Factor(dB)
3. The other emission levels were very low against the limit.
4. Margin value = Emission Level – Limit value

4.2 Conducted Emission Measurement

4.2.1 Limits of Conducted Emission Measurement

Frequency (MHz)	Conducted Limit (dBuV)	
	Quasi-peak	Average
0.15 - 0.5	66 - 56	56 - 46
0.50 - 5.0	56	46
5.0 - 30.0	60	50

Note: 1. The lower limit shall apply at the transition frequencies.

2. The limit decreases in line with the logarithm of the frequency in the range of 0.15 to 0.50MHz.

4.2.2 Test Instruments

Tested date: Mar. 08, 2018

Description & Manufacturer	Model No.	Serial No.	Cal. Date	Cal. Due
Test Receiver ROHDE & SCHWARZ	ESCS 30	100288	Aug. 17, 2017	Aug. 16, 2018
RF signal cable (with 10dB PAD) Woken	5D-FB	Cable-cond2-01	Sep. 08, 2017	Sep. 07, 2018
LISN ROHDE & SCHWARZ (EUT)	ESH3-Z5	835239/001	Mar. 10, 2017	Mar. 09, 2018
LISN ROHDE & SCHWARZ (Peripheral)	ESH3-Z5	100312	Aug. 02, 2017	Aug. 01, 2018
Software ADT	BV ADT_Cond_ V7.3.7.3	NA	NA	NA

Note: 1. The calibration interval of the above test instruments is 12 months and the calibrations are traceable to NML/ROC and NIST/USA.

2. The test was performed in HwaYa Shielded Room 2.

3. The VCCI Site Registration No. is C-2047.

4.2.3 Test Procedures

- The EUT was placed 0.4 meters from the conducting wall of the shielded room with EUT being connected to the power mains through a line impedance stabilization network (LISN). Other support units were connected to the power mains through another LISN. The two LISNs provide 50 ohm/ 50uH of coupling impedance for the measuring instrument.
- Both lines of the power mains connected to the EUT were checked for maximum conducted interference.
- The frequency range from 150kHz to 30MHz was searched. Emission levels under (Limit - 20dB) was not recorded.

NOTE: The resolution bandwidth and video bandwidth of test receiver is 9kHz for quasi-peak detection (QP) and average detection (AV) at frequency 0.15MHz-30MHz.

4.2.4 Deviation from Test Standard

No deviation.

4.2.5 Test Setup

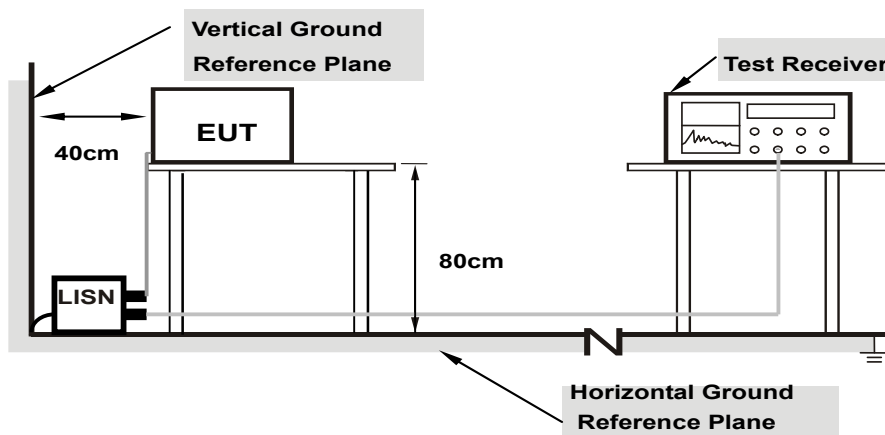

Note: 1.Support units were connected to second LISN.

For the actual test configuration, please refer to the attached file (Test Setup Photo).

4.2.6 EUT Operating Conditions

Same as 4.1.6.

4.2.7 Test Results

Worst-case data: 802.11a

Phase	Line (L)	Detector Function	Quasi-Peak (QP) / Average (AV)
Test Mode	A		

No	Freq. [MHz]	Corr. Factor (dB)	Reading Value		Emission Level		Limit		Margin	
			[dB (uV)]		[dB (uV)]		[dB (uV)]		(dB)	
			Q.P.	AV.	Q.P.	AV.	Q.P.	AV.	Q.P.	AV.
1	0.15781	10.30	49.90	34.45	60.20	44.75	65.58	55.58	-5.38	-10.83
2	0.20469	10.32	41.77	25.89	52.09	36.21	63.42	53.42	-11.33	-17.21
3	0.53281	10.36	25.59	20.41	35.95	30.77	56.00	46.00	-20.05	-15.23
4	2.59766	10.47	22.69	17.85	33.16	28.32	56.00	46.00	-22.84	-17.68
5	4.62891	10.58	24.21	15.55	34.79	26.13	56.00	46.00	-21.21	-19.87
6	10.44141	10.87	28.08	23.09	38.95	33.96	60.00	50.00	-21.05	-16.04

Remarks:

1. Q.P. and AV. are abbreviations of quasi-peak and average individually.
2. The emission levels of other frequencies were very low against the limit.
3. Margin value = Emission level - Limit value
4. Correction factor = Insertion loss + Cable loss
5. Emission Level = Correction Factor + Reading Value.

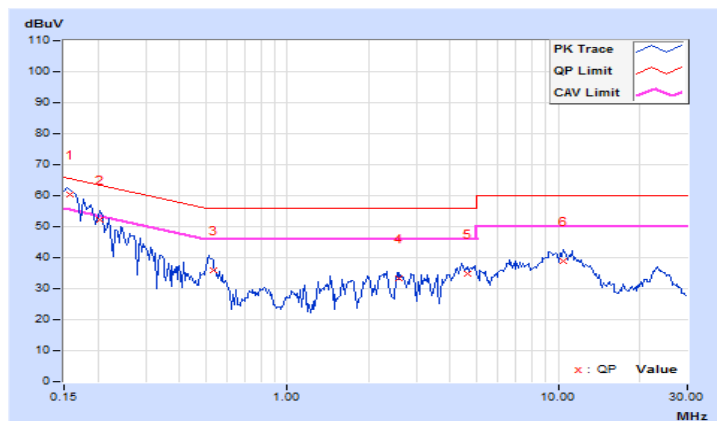

Phase	Neutral (N)	Detector Function	Quasi-Peak (QP) / Average (AV)
Test Mode	A		

No	Freq. [MHz]	Corr. Factor (dB)	Reading Value [dB (uV)]		Emission Level [dB (uV)]		Limit [dB (uV)]		Margin (dB)	
			Q.P.	AV.	Q.P.	AV.	Q.P.	AV.	Q.P.	AV.
			1	0.15781	10.33	49.84	34.00	60.17	44.33	65.58
2	0.21641	10.29	38.84	20.25	49.13	30.54	62.96	52.96	-13.83	-22.42
3	0.51328	10.32	28.12	21.42	38.44	31.74	56.00	46.00	-17.56	-14.26
4	1.35938	10.42	22.20	16.84	32.62	27.26	56.00	46.00	-23.38	-18.74
5	6.39453	10.64	19.93	13.24	30.57	23.88	60.00	50.00	-29.43	-26.12
6	9.50781	10.77	21.92	14.90	32.69	25.67	60.00	50.00	-27.31	-24.33

Remarks:

1. Q.P. and AV. are abbreviations of quasi-peak and average individually.
2. The emission levels of other frequencies were very low against the limit.
3. Margin value = Emission level - Limit value
4. Correction factor = Insertion loss + Cable loss
5. Emission Level = Correction Factor + Reading Value.

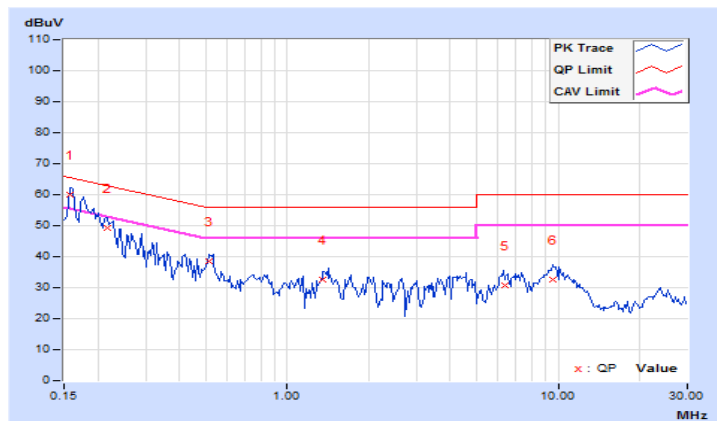

Phase	Line (L)	Detector Function	Quasi-Peak (QP) / Average (AV)
Test Mode	B		

No	Freq. [MHz]	Corr. Factor (dB)	Reading Value [dB (uV)]		Emission Level [dB (uV)]		Limit [dB (uV)]		Margin (dB)	
			Q.P.	AV.	Q.P.	AV.	Q.P.	AV.	Q.P.	AV.
			1	0.15781	10.30	39.88	22.72	50.18	33.02	65.58
2	0.30625	10.33	23.96	18.00	34.29	28.33	60.07	50.07	-25.78	-21.74
3	0.81016	10.38	21.55	17.81	31.93	28.19	56.00	46.00	-24.07	-17.81
4	1.44141	10.41	22.34	17.73	32.75	28.14	56.00	46.00	-23.25	-17.86
5	2.98438	10.49	23.36	18.69	33.85	29.18	56.00	46.00	-22.15	-16.82
6	10.56641	10.88	30.91	26.39	41.79	37.27	60.00	50.00	-18.21	-12.73

Remarks:

1. Q.P. and AV. are abbreviations of quasi-peak and average individually.
2. The emission levels of other frequencies were very low against the limit.
3. Margin value = Emission level - Limit value
4. Correction factor = Insertion loss + Cable loss
5. Emission Level = Correction Factor + Reading Value.

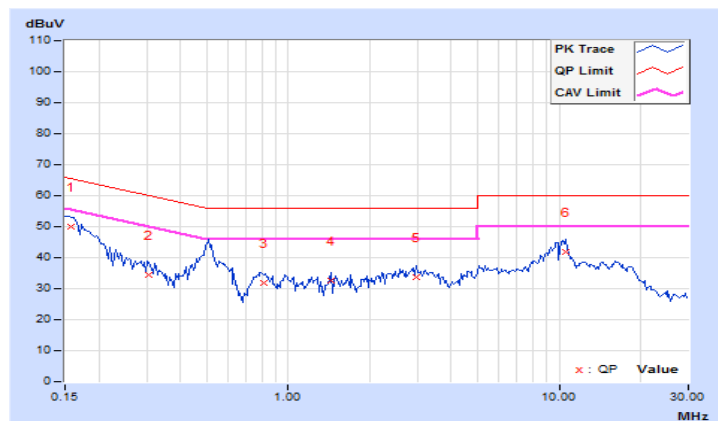

Phase	Neutral (N)	Detector Function	Quasi-Peak (QP) / Average (AV)
Test Mode	B		

No	Freq. [MHz]	Corr. Factor (dB)	Reading Value [dB (uV)]		Emission Level [dB (uV)]		Limit [dB (uV)]		Margin (dB)	
			Q.P.	AV.	Q.P.	AV.	Q.P.	AV.	Q.P.	AV.
			1	0.17344	10.32	37.54	20.70	47.86	31.02	64.79
2	0.51328	10.32	34.24	29.65	44.56	39.97	56.00	46.00	-11.44	-6.03
3	1.23047	10.41	19.61	15.50	30.02	25.91	56.00	46.00	-25.98	-20.09
4	3.06641	10.51	20.51	15.41	31.02	25.92	56.00	46.00	-24.98	-20.08
5	5.46875	10.61	20.65	14.07	31.26	24.68	60.00	50.00	-28.74	-25.32
6	10.40625	10.80	29.85	25.23	40.65	36.03	60.00	50.00	-19.35	-13.97

Remarks:

1. Q.P. and AV. are abbreviations of quasi-peak and average individually.
2. The emission levels of other frequencies were very low against the limit.
3. Margin value = Emission level - Limit value
4. Correction factor = Insertion loss + Cable loss
5. Emission Level = Correction Factor + Reading Value.

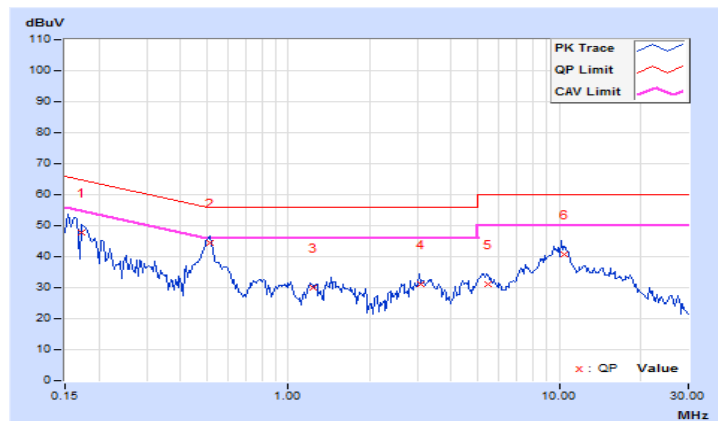

Phase	Line (L)	Detector Function	Quasi-Peak (QP) / Average (AV)
Test Mode	C		

No	Freq. [MHz]	Corr. Factor (dB)	Reading Value [dB (uV)]		Emission Level [dB (uV)]		Limit [dB (uV)]		Margin (dB)	
			Q.P.	AV.	Q.P.	AV.	Q.P.	AV.	Q.P.	AV.
			1	0.16172	10.30	49.90	32.25	60.20	42.55	65.38
2	0.22812	10.33	38.64	22.02	48.97	32.35	62.52	52.52	-13.55	-20.17
3	0.53672	10.36	24.39	20.69	34.75	31.05	56.00	46.00	-21.25	-14.95
4	2.60156	10.47	22.66	19.77	33.13	30.24	56.00	46.00	-22.87	-15.76
5	4.91406	10.60	23.78	15.97	34.38	26.57	56.00	46.00	-21.62	-19.43
6	10.83203	10.90	27.80	22.52	38.70	33.42	60.00	50.00	-21.30	-16.58

Remarks:

1. Q.P. and AV. are abbreviations of quasi-peak and average individually.
2. The emission levels of other frequencies were very low against the limit.
3. Margin value = Emission level - Limit value
4. Correction factor = Insertion loss + Cable loss
5. Emission Level = Correction Factor + Reading Value.

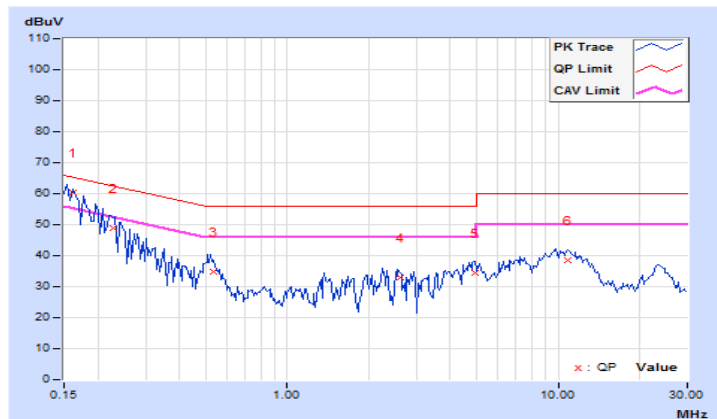

Phase	Neutral (N)	Detector Function	Quasi-Peak (QP) / Average (AV)
Test Mode	C		

No	Freq. [MHz]	Corr. Factor (dB)	Reading Value [dB (uV)]		Emission Level [dB (uV)]		Limit [dB (uV)]		Margin (dB)	
			Q.P.	AV.	Q.P.	AV.	Q.P.	AV.	Q.P.	AV.
			1	0.16172	10.33	49.75	31.48	60.08	41.81	65.38
2	0.22812	10.30	38.62	21.84	48.92	32.14	62.52	52.52	-13.60	-20.38
3	0.51719	10.32	27.87	21.04	38.19	31.36	56.00	46.00	-17.81	-14.64
4	1.44141	10.42	22.30	17.06	32.72	27.48	56.00	46.00	-23.28	-18.52
5	4.00781	10.55	20.38	12.68	30.93	23.23	56.00	46.00	-25.07	-22.77
6	9.57813	10.77	21.62	14.85	32.39	25.62	60.00	50.00	-27.61	-24.38

Remarks:

1. Q.P. and AV. are abbreviations of quasi-peak and average individually.
2. The emission levels of other frequencies were very low against the limit.
3. Margin value = Emission level - Limit value
4. Correction factor = Insertion loss + Cable loss
5. Emission Level = Correction Factor + Reading Value.

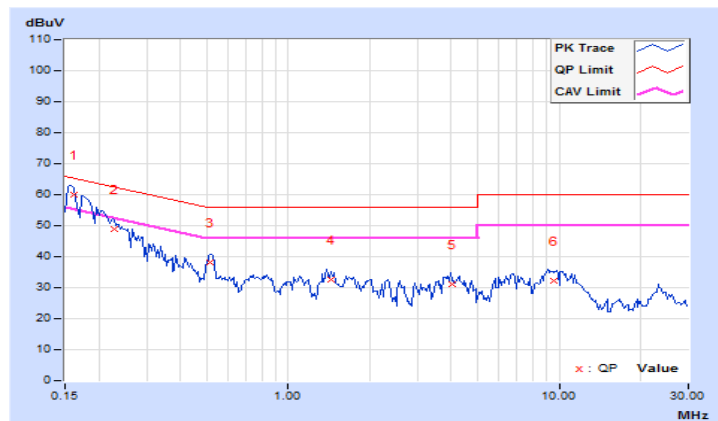

Phase	Line (L)	Detector Function	Quasi-Peak (QP) / Average (AV)
Test Mode	D		

No	Freq. [MHz]	Corr. Factor (dB)	Reading Value [dB (uV)]		Emission Level [dB (uV)]		Limit [dB (uV)]		Margin (dB)	
			Q.P.	AV.	Q.P.	AV.	Q.P.	AV.	Q.P.	AV.
			1	0.17734	10.31	36.09	18.74	46.40	29.05	64.61
2	0.51328	10.35	33.04	28.29	43.39	38.64	56.00	46.00	-12.61	-7.36
3	0.80625	10.38	21.20	17.33	31.58	27.71	56.00	46.00	-24.42	-18.29
4	5.13281	10.61	24.18	18.84	34.79	29.45	60.00	50.00	-25.21	-20.55
5	10.20313	10.86	31.45	26.82	42.31	37.68	60.00	50.00	-17.69	-12.32
6	16.87891	11.29	23.19	18.58	34.48	29.87	60.00	50.00	-25.52	-20.13

Remarks:

1. Q.P. and AV. are abbreviations of quasi-peak and average individually.
2. The emission levels of other frequencies were very low against the limit.
3. Margin value = Emission level - Limit value
4. Correction factor = Insertion loss + Cable loss
5. Emission Level = Correction Factor + Reading Value.

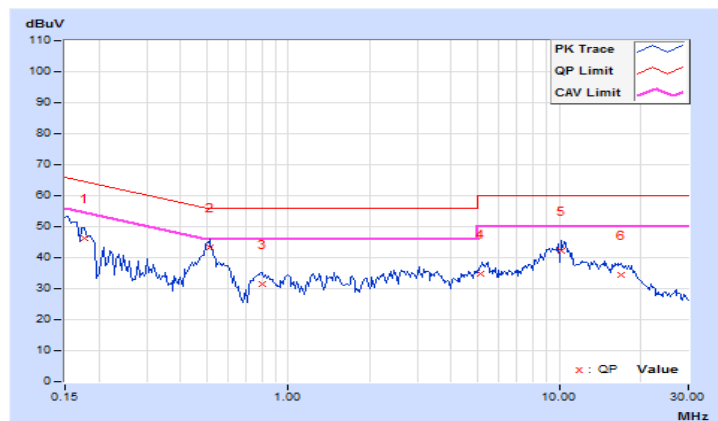

Phase	Neutral (N)	Detector Function	Quasi-Peak (QP) / Average (AV)
Test Mode	D		

No	Freq. [MHz]	Corr. Factor (dB)	Reading Value [dB (uV)]		Emission Level [dB (uV)]		Limit [dB (uV)]		Margin (dB)	
			Q.P.	AV.	Q.P.	AV.	Q.P.	AV.	Q.P.	AV.
			1	0.20078	10.29	31.48	15.47	41.77	25.76	63.58
2	0.50547	10.32	34.30	30.25	44.62	40.57	56.00	46.00	-11.38	-5.43
3	0.76328	10.36	18.59	14.78	28.95	25.14	56.00	46.00	-27.05	-20.86
4	1.45313	10.42	19.26	14.43	29.68	24.85	56.00	46.00	-26.32	-21.15
5	5.20703	10.60	21.68	15.52	32.28	26.12	60.00	50.00	-27.72	-23.88
6	10.35547	10.80	29.95	25.31	40.75	36.11	60.00	50.00	-19.25	-13.89

Remarks:

1. Q.P. and AV. are abbreviations of quasi-peak and average individually.
2. The emission levels of other frequencies were very low against the limit.
3. Margin value = Emission level - Limit value
4. Correction factor = Insertion loss + Cable loss
5. Emission Level = Correction Factor + Reading Value.

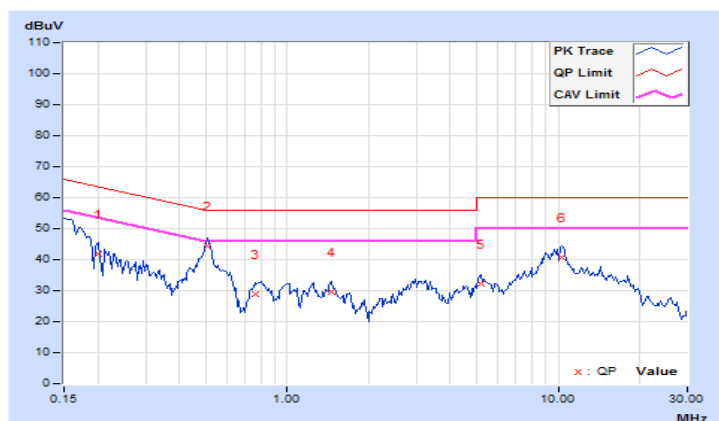

4.3 Transmit Power Measurement

4.3.1 Limits of Transmit Power Measurement

Operation Band	EUT Category		Limit
U-NII-1	-	Outdoor Access Point	1 Watt (30 dBm) (Max. e.i.r.p \leq 125mW(21 dBm) at any elevation angle above 30 degrees as measured from the horizon)
	-	Fixed point-to-point Access Point	1 Watt (30 dBm)
	√ (Test Mode A)	Indoor Access Point	1 Watt (30 dBm)
	√ (Test Mode C)	Mobile and Portable client device	250mW (24 dBm)
U-NII-2A	-	-	250mW (24 dBm) or 11 dBm+10 log B*
U-NII-2C	-	-	250mW (24 dBm) or 11 dBm+10 log B*
U-NII-3	√	-	1 Watt (30 dBm)

*B is the 26 dB emission bandwidth in megahertz

Per KDB 662911 Method of conducted output power measurement on IEEE 802.11 devices,

Array Gain = 0 dB (i.e., no array gain) for $N_{ANT} \leq 4$;

Array Gain = 0 dB (i.e., no array gain) for channel widths \geq 40 MHz for any N_{ANT} ;

Array Gain = $5 \log(N_{ANT}/N_{SS})$ dB or 3 dB, whichever is less for 20-MHz channel widths with $N_{ANT} \geq 5$.

For power measurements on all other devices: Array Gain = $10 \log(N_{ANT}/N_{SS})$ dB.

4.3.2 Test Setup

For Power Output

802.11a, 802.11n (HT20), 802.11n (HT40)

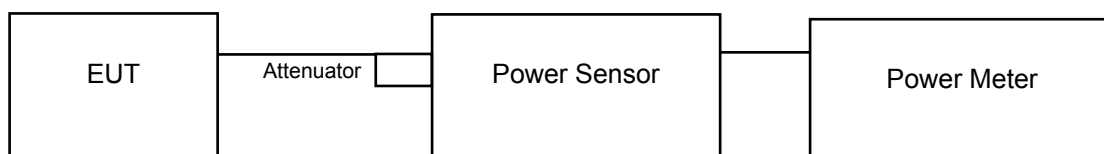

802.11ac (VHT80)

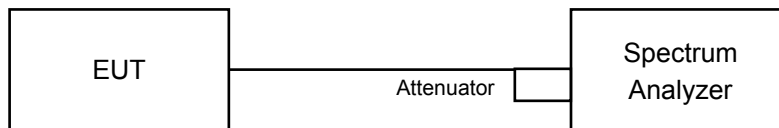

4.3.3 Test Instruments

Refer to section 4.1.2 to get information of above instrument.

4.3.4 Test Procedure

For Average Power Measurement

For 802.11a, 802.11n (HT20), 802.11n (HT40)

Method PM is used to perform output power measurement, trigger and gating function of wide band power meter is enabled to measure max output power of TX on burst. Duty factor is not added to measured value.

For 802.11ac (VHT80)

- a. Set span to encompass the entire 26 dB EBW (or, alternatively, the entire 99% occupied bandwidth) of the signal.
- b. Set sweep trigger to “free run”.
- c. Set RBW = 1 MHz.
- d. Set VBW \geq 3 MHz.
- e. Number of points in sweep \geq 2 Span / RBW.
- f. Sweep time \leq (number of points in sweep) * T
- g. Using emission bandwidth to determine the frequency span for integration the channel bandwidth.
- h. Detector = RMS.
- i. Trace mode = max hold.
- j. Allow max hold to run for at least 60 seconds, or longer as needed to allow the trace to stabilize.
- k. Compute power by integrating the spectrum across the EBW (or, alternatively, the entire 99% occupied bandwidth) of the signal using the instrument’s band power measurement function with band limits set equal to the EBW (or occupied bandwidth) band edges. If the instrument does not have a band power function, sum the spectrum levels (in power units) at 1 MHz intervals extending across the EBW (or, alternatively, the entire 99% occupied bandwidth) of the spectrum.

4.3.5 Deviation from Test Standard

No deviation.

4.3.6 EUT Operating Conditions

The software provided by client to enable the EUT under transmission condition continuously at lowest, middle and highest channel frequencies individually.

4.3.7 Test Result

Power Output:

Test Mode A

CDD Mode

802.11a

Chan.	Freq. (MHz)	Maximum Conducted Power (dBm)		Total Power (mW)	Total Power (dBm)	Power Limit (dBm)	Pass / Fail
		Chain 0	Chain 1				
36	5180	18.01	18.04	126.921	21.04	30.00	Pass
40	5200	21.41	21.42	277.033	24.43	30.00	Pass
48	5240	20.54	20.85	234.859	23.71	30.00	Pass
149	5745	22.36	22.14	335.869	25.26	30.00	Pass
157	5785	24.08	22.36	428.046	26.31	30.00	Pass
165	5825	24.05	22.48	431.108	26.35	30.00	Pass

802.11n (HT20)

Chan.	Freq. (MHz)	Maximum Conducted Power (dBm)		Total Power (mW)	Total Power (dBm)	Power Limit (dBm)	Pass / Fail
		Chain 0	Chain 1				
36	5180	17.62	17.59	115.222	20.62	30.00	Pass
40	5200	21.46	21.40	277.997	24.44	30.00	Pass
48	5240	20.59	20.78	234.225	23.70	30.00	Pass
149	5745	22.31	22.19	335.793	25.26	30.00	Pass
157	5785	23.72	22.32	406.113	26.09	30.00	Pass
165	5825	23.79	23.41	458.612	26.61	30.00	Pass

802.11n (HT40)

Chan.	Freq. (MHz)	Maximum Conducted Power (dBm)		Total Power (mW)	Total Power (dBm)	Power Limit (dBm)	Pass / Fail
		Chain 0	Chain 1				
38	5190	15.10	15.17	65.244	18.15	30.00	Pass
46	5230	19.75	19.79	189.686	22.78	30.00	Pass
151	5755	24.01	23.10	455.942	26.59	30.00	Pass
159	5795	23.80	23.43	460.176	26.63	30.00	Pass

802.11ac (VHT80)

Chan.	Freq. (MHz)	Maximum Conducted Power (dBm)		Total Power (mW)	Total Power (dBm)	Power Limit (dBm)	Pass / Fail
		Chain 0	Chain 1				
42	5210	14.05	14.04	50.761	17.06	30.00	Pass
155	5775	19.58	19.76	185.406	22.68	30.00	Pass

Beamforming Mode

802.11n (HT20)

Chan.	Freq. (MHz)	Maximum Conducted Power (dBm)		Total Power (mW)	Total Power (dBm)	Power Limit (dBm)	Pass / Fail
		Chain 0	Chain 1				
36	5180	14.61	14.58	57.615	17.61	27.00	Pass
40	5200	18.45	18.39	139.008	21.43	27.00	Pass
48	5240	17.58	17.77	117.121	20.69	27.00	Pass
149	5745	19.30	19.18	167.908	22.25	27.00	Pass
157	5785	20.71	19.31	203.071	23.08	27.00	Pass
165	5825	20.78	20.40	229.322	23.60	27.00	Pass

Note: Directional Gain = $5.99 + 10\log(2) = 9\text{dBi} > 6\text{dBi}$, so the limit shall be reduced to $30 - (9 - 6) = 27\text{dBm}$.

802.11n (HT40)

Chan.	Freq. (MHz)	Maximum Conducted Power (dBm)		Total Power (mW)	Total Power (dBm)	Power Limit (dBm)	Pass / Fail
		Chain 0	Chain 1				
38	5190	12.09	12.16	32.625	15.14	27.00	Pass
46	5230	16.74	16.78	94.849	19.77	27.00	Pass
151	5755	21.00	20.09	227.986	23.58	27.00	Pass
159	5795	20.79	20.42	230.104	23.62	27.00	Pass

Note: Directional Gain = $5.99 + 10\log(2) = 9\text{dBi} > 6\text{dBi}$, so the limit shall be reduced to $30 - (9 - 6) = 27\text{dBm}$.

802.11ac (VHT80)

Chan.	Freq. (MHz)	Maximum Conducted Power (dBm)		Total Power (mW)	Total Power (dBm)	Power Limit (dBm)	Pass / Fail
		Chain 0	Chain 1				
42	5210	11.04	11.03	25.382	14.05	27.00	Pass
155	5775	16.57	16.75	92.709	19.67	27.00	Pass

Note: Directional Gain = $5.99 + 10\log(2) = 9\text{dBi} > 6\text{dBi}$, so the limit shall be reduced to $30 - (9 - 6) = 27\text{dBm}$.

Test Mode C

802.11a

Chan.	Freq. (MHz)	Maximum Conducted Power (dBm)		Total Power (mW)	Total Power (dBm)	Power Limit (dBm)	Pass / Fail
		Chain 0	Chain 1				
36	5180	14.62	13.92	53.633	17.29	24.00	Pass
40	5200	14.55	13.98	53.513	17.28	24.00	Pass
48	5240	14.33	14.11	52.865	17.23	24.00	Pass
149	5745	12.18	12.37	33.778	15.29	30.00	Pass
157	5785	9.12	8.84	15.822	11.99	30.00	Pass
165	5825	8.63	8.34	14.118	11.50	30.00	Pass

802.11n (HT20)

Chan.	Freq. (MHz)	Maximum Conducted Power (dBm)		Total Power (mW)	Total Power (dBm)	Power Limit (dBm)	Pass / Fail
		Chain 0	Chain 1				
36	5180	14.59	13.75	52.488	17.20	24.00	Pass
40	5200	14.51	13.79	52.182	17.18	24.00	Pass
48	5240	14.27	13.94	51.504	17.12	24.00	Pass
149	5745	12.10	12.30	33.200	15.21	30.00	Pass
157	5785	9.64	9.40	17.914	12.53	30.00	Pass
165	5825	8.26	8.10	13.156	11.19	30.00	Pass

802.11n (HT40)

Chan.	Freq. (MHz)	Maximum Conducted Power (dBm)		Total Power (mW)	Total Power (dBm)	Power Limit (dBm)	Pass / Fail
		Chain 0	Chain 1				
38	5190	10.32	10.25	21.358	13.30	24.00	Pass
46	5230	14.12	14.18	52.005	17.16	24.00	Pass
151	5755	13.74	13.67	46.940	16.72	30.00	Pass
159	5795	11.38	11.34	27.354	14.37	30.00	Pass

802.11ac (VHT80)

Chan.	Freq. (MHz)	Maximum Conducted Power (dBm)		Total Power (mW)	Total Power (dBm)	Power Limit (dBm)	Pass / Fail
		Chain 0	Chain 1				
42	5210	8.12	7.53	12.148	10.85	24.00	Pass
155	5775	14.20	13.96	51.192	17.09	30.00	Pass

4.4 Occupied Bandwidth Measurement

4.4.1 Test Setup

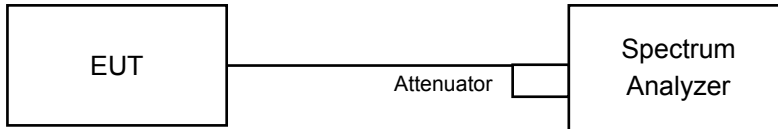

4.4.2 Test Instruments

Refer to section 4.1.2 to get information of above instrument.

4.4.3 Test Procedure

The transmitter output was connected to the spectrum analyzer through an attenuator. The bandwidth of the fundamental frequency was measured by spectrum analyzer with resolution bandwidth in the range of 1% to 5% of the anticipated emission bandwidth, and a video bandwidth at least 3x the resolution bandwidth and set the detector to sampling. The width of a frequency band such that, below the lower and above the upper frequency limits, the mean powers emitted are each equal to a specified percentage 0.5 %of the total mean power of a given emission.

4.4.4 Test Result

Test Mode A

802.11a

Chan.	Freq. (MHz)	Occupied Bandwidth (MHz)	
		Chain 0	Chain 1
36	5180	16.56	16.56
40	5200	21.00	24.84
48	5240	17.56	17.13
149	5745	21.12	22.80
157	5785	23.88	26.04
165	5825	25.92	30.12

802.11n (HT20)

Chan.	Freq. (MHz)	Occupied Bandwidth (MHz)	
		Chain 0	Chain 1
36	5180	17.64	17.76
40	5200	22.44	26.64
48	5240	18.52	18.17
149	5745	23.16	24.48
157	5785	25.92	28.32
165	5825	27.36	32.40

802.11n (HT40)

Chan.	Freq. (MHz)	Occupied Bandwidth (MHz)	
		Chain 0	Chain 1
38	5190	36.12	36.12
46	5230	36.48	36.72
151	5755	42.96	44.76
159	5795	41.88	46.32

802.11ac (VHT80)

Chan.	Freq. (MHz)	Occupied Bandwidth (MHz)	
		Chain 0	Chain 1
42	5210	75.84	75.60
155	5775	76.08	76.08

Spectrum Plot of Worst Value

802.11a

802.11n (HT20)

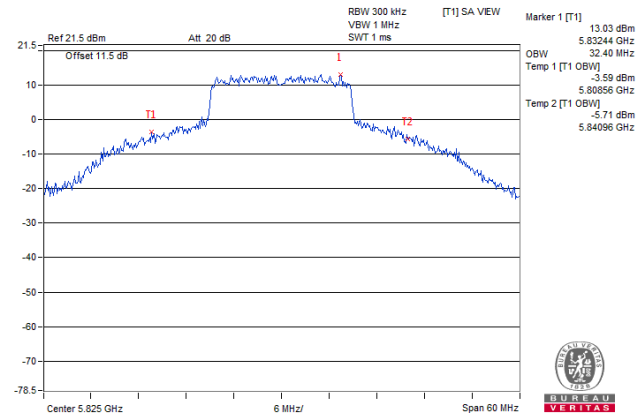
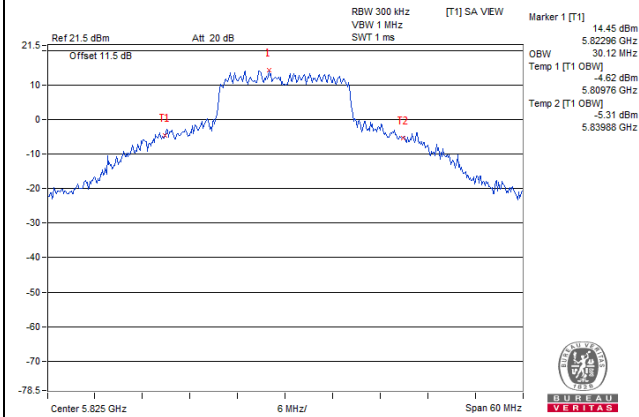

802.11n (HT40)

802.11ac (VHT80)

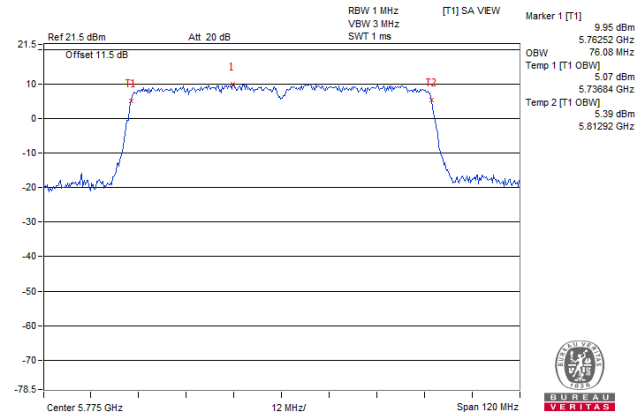
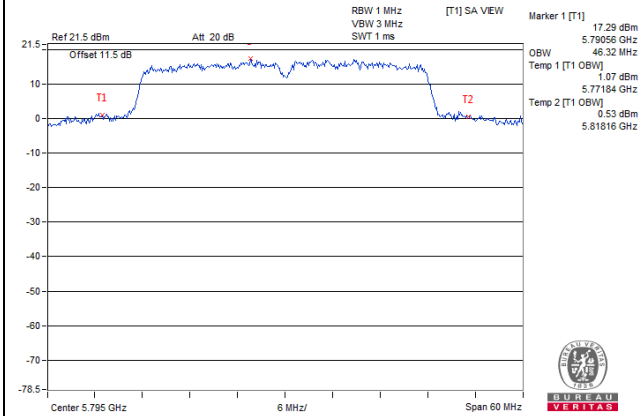

Test Mode C

802.11a

Chan.	Freq. (MHz)	Occupied Bandwidth (MHz)	
		Chain 0	Chain 1
36	5180	16.80	16.68
40	5200	16.80	16.68
48	5240	16.80	16.68
149	5745	16.68	16.68
157	5785	16.80	16.56
165	5825	16.68	16.56

802.11n (HT20)

Chan.	Freq. (MHz)	Occupied Bandwidth (MHz)	
		Chain 0	Chain 1
36	5180	18.00	18.00
40	5200	17.88	17.88
48	5240	17.88	17.88
149	5745	17.76	17.76
157	5785	17.76	17.88
165	5825	17.76	17.76

802.11n (HT40)

Chan.	Freq. (MHz)	Occupied Bandwidth (MHz)	
		Chain 0	Chain 1
38	5190	36.72	36.84
46	5230	36.72	37.08
151	5755	36.84	36.72
159	5795	36.84	36.84

802.11ac (VHT80)

Chan.	Freq. (MHz)	Occupied Bandwidth (MHz)	
		Chain 0	Chain 1
42	5210	76.08	76.08
155	5775	75.84	76.08

Spectrum Plot of Worst Value

802.11a

802.11n (HT20)

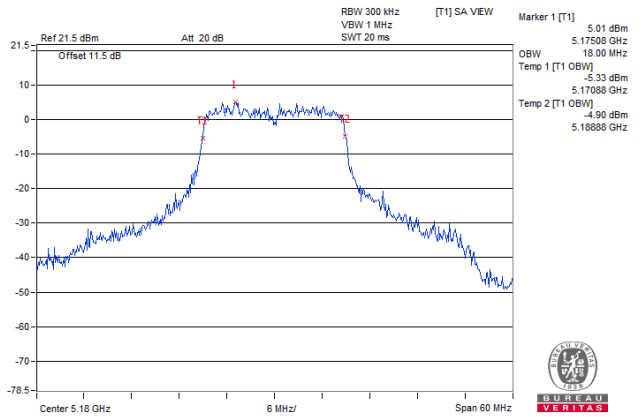
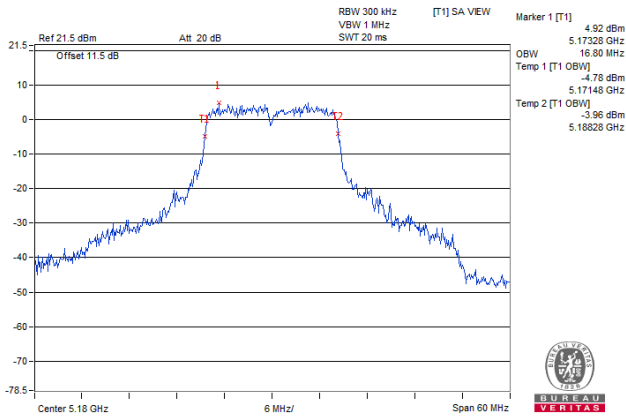

802.11n (HT40)

802.11ac (VHT80)

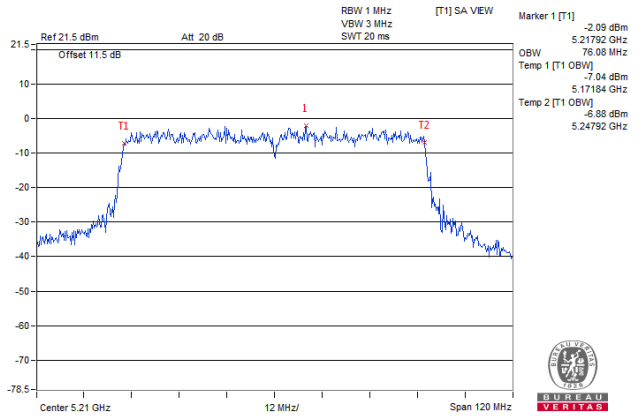
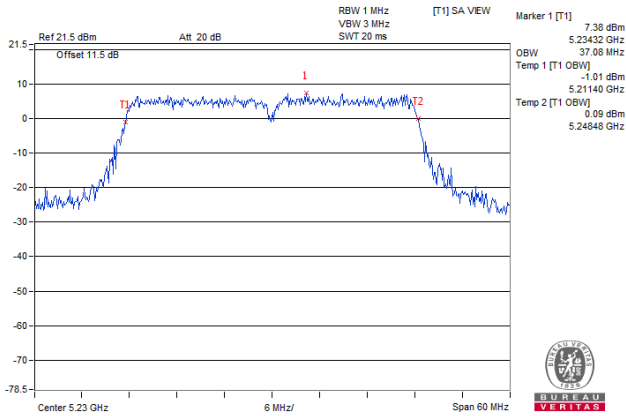

4.5 Peak Power Spectral Density Measurement

4.5.1 Limits of Peak Power Spectral Density Measurement

Operation Band	EUT Category		Limit
U-NII-1	-	Outdoor Access Point	17dBm/ MHz
	-	Fixed point-to-point Access Point	
	√ (Test Mode A)	Indoor Access Point	11dBm/ MHz
	√ (Test Mode C)	Mobile and Portable client device	
U-NII-2A	-	11dBm/ MHz	
U-NII-2C	-	11dBm/ MHz	
U-NII-3	√	30dBm/ 500kHz	

4.5.2 Test Setup

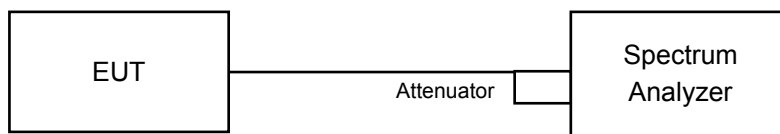

4.5.3 Test Instruments

Refer to section 4.1.2 to get information of above instrument.

4.5.4 Test Procedures

For U-NII-1 band:

Duty cycle of test signal is < 98%

Using method SA-2

- Set span to encompass the entire emission bandwidth (EBW) of the signal.
- Set RBW = 1MHz, Set VBW \geq 3 MHz, Detector = RMS
- Set Channel power measure = 1MHz
- Sweep time = auto, trigger set to "free run".
- Trace average at least 100 traces in power averaging mode.
- Record the max value and add $10 \log (1/\text{duty cycle})$

For U-NII-3 band:

Duty cycle of test signal is < 98%

- a. Set span to encompass the entire emission bandwidth (EBW) of the signal.
- b. Set RBW = 300 kHz, Set VBW \geq 1 MHz, Detector = RMS
- c. Use the peak marker function to determine the maximum power level in any 300 kHz band segment within the fundamental EBW.
- d. Scale the observed power level to an equivalent value in 500 kHz by adjusting (reducing) the measured power by a bandwidth correction factor (BWCF) where $BWCF = 10\log(500 \text{ kHz} / 300 \text{ kHz})$
- e. Sweep time = auto, trigger set to "free run".
- f. Trace average at least 100 traces in power averaging mode.
- g. Record the max value and add $10 \log (1/\text{duty cycle})$

4.5.5 Deviation from Test Standard

No deviation.

4.5.6 EUT Operating Conditions

Same as 4.3.6.

4.5.7 Test Results

Test Mode A

For U-NII-1 Band

802.11a

Chan.	Freq. (MHz)	PSD w/o Duty Factor (dBm/MHz)		Duty Factor (dB)	Total PSD with Duty Factor (dBm/MHz)	Max. Limit (dBm/MHz)	Pass / Fail
		Chain 0	Chain 1				
36	5180	3.80	3.74	0.17	6.95	14.00	Pass
40	5200	7.29	7.28	0.17	10.46	14.00	Pass
48	5240	9.10	8.67	0.17	12.07	14.00	Pass

Note:

1. Method 1 of power density measurement of KDB 662911 is using for calculating total power density. Total power density is summing entire spectra across corresponding frequency bins on the various outputs by computer.
2. Directional gain = $5.99\text{dBi} + 10\log(2) = 9\text{dBi} > 6\text{dBi}$, so the limit shall be reduced to $17 - (9 - 6) = 14\text{dBm}$.
3. Refer to section 3.3 for duty cycle spectrum plot.

802.11n (HT20)

Chan.	Freq. (MHz)	PSD w/o Duty Factor (dBm/MHz)		Duty Factor (dB)	Total PSD with Duty Factor (dBm/MHz)	Max. Limit (dBm/MHz)	Pass / Fail
		Chain 0	Chain 1				
36	5180	3.11	3.34	0.10	6.34	14.00	Pass
40	5200	6.92	7.22	0.10	10.18	14.00	Pass
48	5240	8.34	8.45	0.10	11.50	14.00	Pass

Note:

1. Method 1 of power density measurement of KDB 662911 is using for calculating total power density. Total power density is summing entire spectra across corresponding frequency bins on the various outputs by computer.
2. Directional gain = $5.99\text{dBi} + 10\log(2) = 9\text{dBi} > 6\text{dBi}$, so the limit shall be reduced to $17 - (9 - 6) = 14\text{dBm}$.
3. Refer to section 3.3 for duty cycle spectrum plot.

802.11n (HT40)

Chan.	Freq. (MHz)	PSD w/o Duty Factor (dBm/MHz)		Duty Factor (dB)	Total PSD with Duty Factor (dBm/MHz)	Max. Limit (dBm/MHz)	Pass / Fail
		Chain 0	Chain 1				
38	5190	-2.31	-1.88	0.15	1.07	14.00	Pass
46	5230	2.59	2.95	0.15	5.94	14.00	Pass

Note:

1. Method 1 of power density measurement of KDB 662911 is using for calculating total power density. Total power density is summing entire spectra across corresponding frequency bins on the various outputs by computer.
2. Directional gain = $5.99\text{dBi} + 10\log(2) = 9\text{dBi} > 6\text{dBi}$, so the limit shall be reduced to $17 - (9 - 6) = 14\text{dBm}$.
3. Refer to section 3.3 for duty cycle spectrum plot.

802.11ac (VHT80)

Chan.	Freq. (MHz)	PSD w/o Duty Factor (dBm/MHz)		Duty Factor (dB)	Total PSD with Duty Factor (dBm/MHz)	Max. Limit (dBm/MHz)	Pass / Fail
		Chain 0	Chain 1				
42	5210	-6.70	-6.43	0.35	-3.20	14.00	Pass

Note:

- Method 1 of power density measurement of KDB 662911 is using for calculating total power density. Total power density is summing entire spectra across corresponding frequency bins on the various outputs by computer.
- Directional gain = $5.99\text{dBi} + 10\log(2) = 9\text{dBi} > 6\text{dBi}$, so the limit shall be reduced to $17 - (9 - 6) = 14\text{dBm}$.
- Refer to section 3.3 for duty cycle spectrum plot.

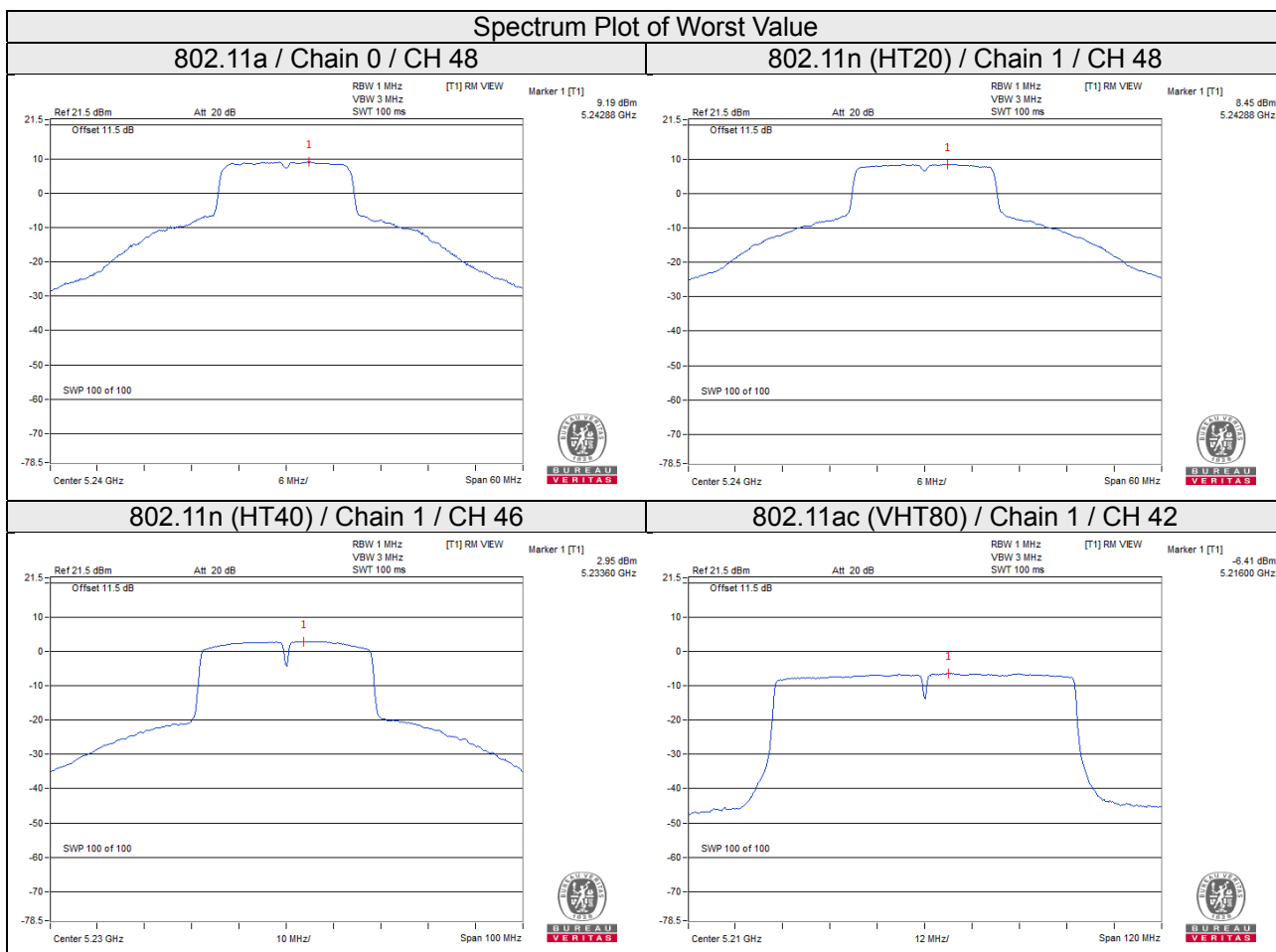

For U-NII-3 Band

802.11a

TX chain	Chan.	Freq. (MHz)	PSD W/O Duty Factor		10 log (N=2) dB	Duty Factor (dB)	Total PSD With Duty Factor (dBm/500kHz)	Limit (dBm/500kHz)	Pass / Fail
			(dBm/300kHz)	(dBm/500kHz)					
0	149	5745	0.52	2.74	3.01	0.17	5.92	27.00	Pass
	157	5785	0.79	3.01	3.01	0.17	6.19	27.00	Pass
	165	5825	0.62	2.84	3.01	0.17	6.02	27.00	Pass
1	149	5745	0.38	2.60	3.01	0.17	5.78	27.00	Pass
	157	5785	0.64	2.86	3.01	0.17	6.04	27.00	Pass
	165	5825	0.80	3.02	3.01	0.17	6.20	27.00	Pass

Note:

- Method 1 of power density measurement of KDB 662911 is using for calculating total power density. Total power density is summing entire spectra across corresponding frequency bins on the various outputs by computer.
- Directional gain = $5.99\text{dBi} + 10\log(2) = 9\text{dBi} > 6\text{dBi}$, so the limit shall be reduced to $30 - (9 - 6) = 27\text{dBm}$.
- Refer to section 3.3 for duty cycle spectrum plot.

802.11n (HT20)

TX chain	Chan.	Freq. (MHz)	PSD W/O Duty Factor		10 log (N=2) dB	Duty Factor (dB)	Total PSD With Duty Factor (dBm/500kHz)	Limit (dBm/500kHz)	Pass / Fail
			(dBm/300kHz)	(dBm/500kHz)					
0	149	5745	0.34	2.56	3.01	0.10	5.67	27.00	Pass
	157	5785	0.46	2.68	3.01	0.10	5.79	27.00	Pass
	165	5825	0.00	2.22	3.01	0.10	5.33	27.00	Pass
1	149	5745	0.27	2.49	3.01	0.10	5.60	27.00	Pass
	157	5785	0.45	2.67	3.01	0.10	5.78	27.00	Pass
	165	5825	0.63	2.85	3.01	0.10	5.96	27.00	Pass

Note:

- Method 1 of power density measurement of KDB 662911 is using for calculating total power density. Total power density is summing entire spectra across corresponding frequency bins on the various outputs by computer.
- Directional gain = $5.99\text{dBi} + 10\log(2) = 9\text{dBi} > 6\text{dBi}$, so the limit shall be reduced to $30 - (9 - 6) = 27\text{dBm}$.
- Refer to section 3.3 for duty cycle spectrum plot.

802.11n (HT40)

TX chain	Chan.	Freq. (MHz)	PSD W/O Duty Factor		10 log (N=2) dB	Duty Factor (dB)	Total PSD With Duty Factor (dBm/500kHz)	Limit (dBm/500kHz)	Pass / Fail
			(dBm/300kHz)	(dBm/500kHz)					
0	151	5755	-1.86	0.36	3.01	0.15	3.52	27.00	Pass
	159	5795	-2.37	-0.15	3.01	0.15	3.01	27.00	Pass
1	151	5755	-2.18	0.04	3.01	0.15	3.20	27.00	Pass
	159	5795	-2.39	-0.17	3.01	0.15	2.99	27.00	Pass

Note:

1. Method 1 of power density measurement of KDB 662911 is using for calculating total power density. Total power density is summing entire spectra across corresponding frequency bins on the various outputs by computer.
2. Directional gain = $5.99\text{dBi} + 10\log(2) = 9\text{dBi} > 6\text{dBi}$, so the limit shall be reduced to $30 - (9 - 6) = 27\text{dBm}$.
3. Refer to section 3.3 for duty cycle spectrum plot.

802.11ac (VHT80)

TX chain	Chan.	Freq. (MHz)	PSD W/O Duty Factor		10 log (N=2) dB	Duty Factor (dB)	Total PSD With Duty Factor (dBm/500kHz)	Limit (dBm/500kHz)	Pass / Fail
			(dBm/300kHz)	(dBm/500kHz)					
0	155	5775	-9.09	-6.87	3.01	0.35	-3.51	27.00	Pass
1	155	5775	-9.03	-6.81	3.01	0.35	-3.45	27.00	Pass

Note:

1. Method 1 of power density measurement of KDB 662911 is using for calculating total power density. Total power density is summing entire spectra across corresponding frequency bins on the various outputs by computer.
2. Directional gain = $5.99\text{dBi} + 10\log(2) = 9\text{dBi} > 6\text{dBi}$, so the limit shall be reduced to $30 - (9 - 6) = 27\text{dBm}$.
3. Refer to section 3.3 for duty cycle spectrum plot.

Spectrum Plot of Worst Value

802.11a

802.11n (HT20)

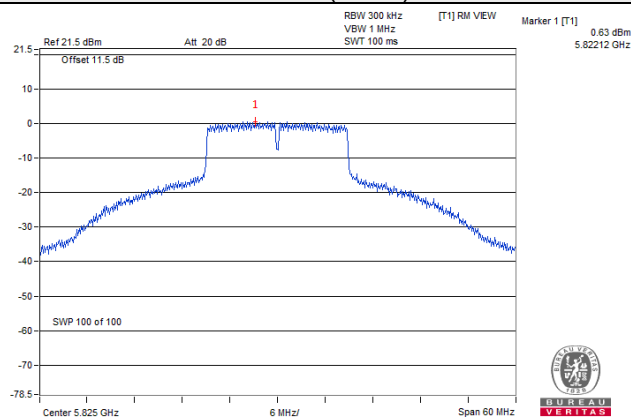
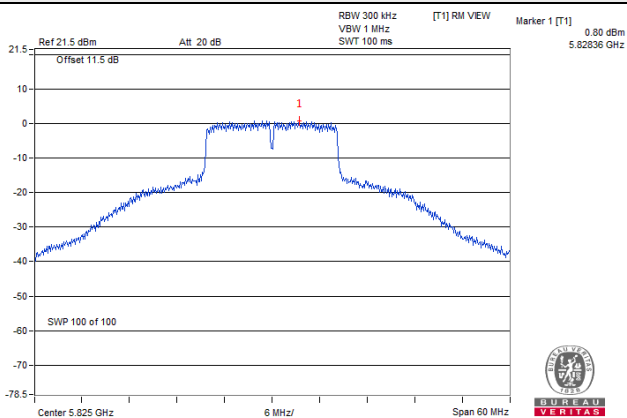

802.11n (HT40)

802.11ac (VHT80)

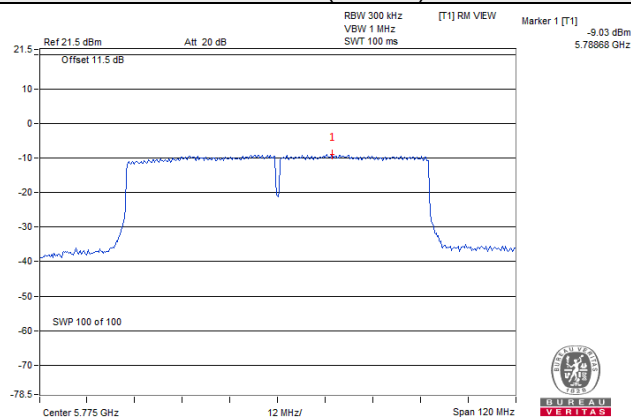
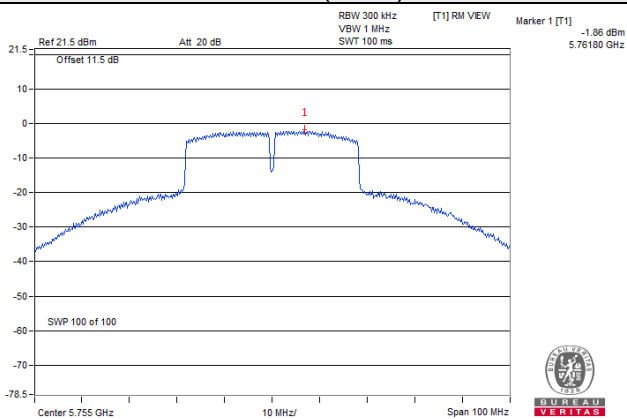

Test Mode C
For U-NII-1 Band

802.11a

Chan.	Freq. (MHz)	PSD w/o Duty Factor (dBm/MHz)		Duty Factor (dB)	Total PSD with Duty Factor (dBm/MHz)	Max. Limit (dBm/MHz)	Pass / Fail
		Chain 0	Chain 1				
36	5180	-0.05	0.18	0.22	3.30	9.16	Pass
40	5200	0.11	0.30	0.22	3.44	9.16	Pass
48	5240	0.41	-0.01	0.22	3.44	9.16	Pass

Note:

- Method 1 of power density measurement of KDB 662911 is using for calculating total power density. Total power density is summing entire spectra across corresponding frequency bins on the various outputs by computer.
- Directional gain = $4.83\text{dBi} + 10\log(2) = 7.84\text{dBi} > 6\text{dBi}$, so the limit shall be reduced to $11 - (7.84 - 6) = 9.16\text{dBm}$.
- Refer to section 3.3 for duty cycle spectrum plot.

802.11n (HT20)

Chan.	Freq. (MHz)	PSD w/o Duty Factor (dBm/MHz)		Duty Factor (dB)	Total PSD with Duty Factor (dBm/MHz)	Max. Limit (dBm/MHz)	Pass / Fail
		Chain 0	Chain 1				
36	5180	-0.12	0.00	0.22	3.17	9.16	Pass
40	5200	0.04	0.32	0.22	3.41	9.16	Pass
48	5240	0.23	-0.40	0.22	3.16	9.16	Pass

Note:

- Method 1 of power density measurement of KDB 662911 is using for calculating total power density. Total power density is summing entire spectra across corresponding frequency bins on the various outputs by computer.
- Directional gain = $4.83\text{dBi} + 10\log(2) = 7.84\text{dBi} > 6\text{dBi}$, so the limit shall be reduced to $11 - (7.84 - 6) = 9.16\text{dBm}$.
- Refer to section 3.3 for duty cycle spectrum plot.

802.11n (HT40)

Chan.	Freq. (MHz)	PSD w/o Duty Factor (dBm/MHz)		Duty Factor (dB)	Total PSD with Duty Factor (dBm/MHz)	Max. Limit (dBm/MHz)	Pass / Fail
		Chain 0	Chain 1				
38	5190	-7.86	-7.57	0.30	-4.40	9.16	Pass
46	5230	-3.08	-3.00	0.30	0.27	9.16	Pass

Note:

- Method 1 of power density measurement of KDB 662911 is using for calculating total power density. Total power density is summing entire spectra across corresponding frequency bins on the various outputs by computer.
- Directional gain = $4.83\text{dBi} + 10\log(2) = 7.84\text{dBi} > 6\text{dBi}$, so the limit shall be reduced to $11 - (7.84 - 6) = 9.16\text{dBm}$.
- Refer to section 3.3 for duty cycle spectrum plot.

802.11ac (VHT80)

Chan.	Freq. (MHz)	PSD w/o Duty Factor (dBm/MHz)		Duty Factor (dB)	Total PSD with Duty Factor (dBm/MHz)	Max. Limit (dBm/MHz)	Pass / Fail
		Chain 0	Chain 1				
42	5210	-13.17	-12.83	0.71	-9.28	9.16	Pass

Note:

- Method 1 of power density measurement of KDB 662911 is using for calculating total power density. Total power density is summing entire spectra across corresponding frequency bins on the various outputs by computer.
- Directional gain = $4.83\text{dBi} + 10\log(2) = 7.84\text{dBi} > 6\text{dBi}$, so the limit shall be reduced to $11 - (7.84 - 6) = 9.16\text{dBm}$.
- Refer to section 3.3 for duty cycle spectrum plot.

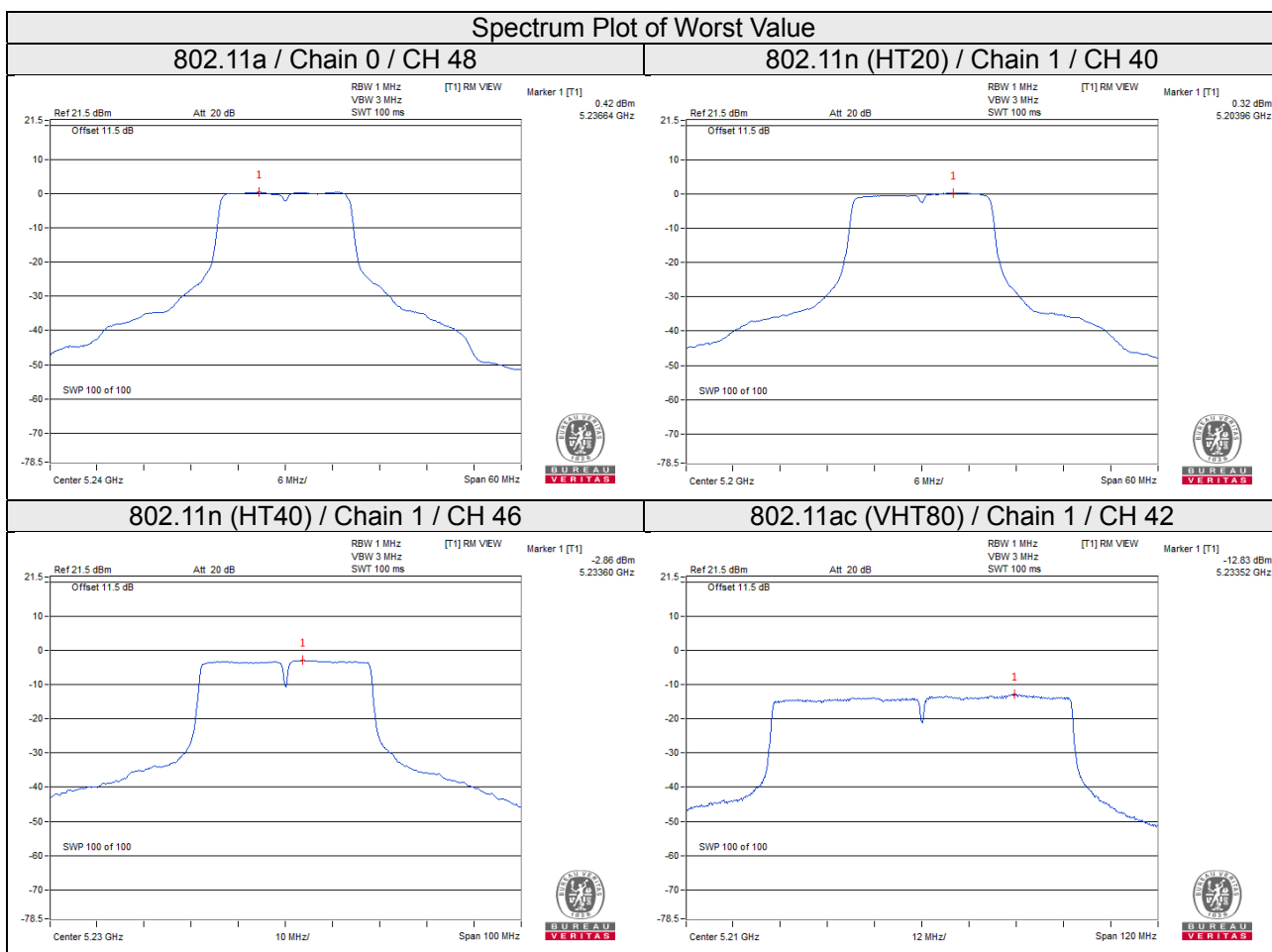

For U-NII-3 Band

802.11a

TX chain	Chan.	Freq. (MHz)	PSD W/O Duty Factor		10 log (N=2) dB	Duty Factor (dB)	Total PSD With Duty Factor (dBm/500kHz)	Limit (dBm/500kHz)	Pass / Fail
			(dBm/300kHz)	(dBm/500kHz)					
0	149	5745	-10.28	-8.06	3.01	0.22	-4.83	28.16	Pass
	157	5785	-13.42	-11.20	3.01	0.22	-7.97	28.16	Pass
	165	5825	-14.28	-12.06	3.01	0.22	-8.83	28.16	Pass
1	149	5745	-10.18	-7.96	3.01	0.22	-4.73	28.16	Pass
	157	5785	-13.80	-11.58	3.01	0.22	-8.35	28.16	Pass
	165	5825	-14.45	-12.23	3.01	0.22	-9.00	28.16	Pass

Note:

1. Method 1 of power density measurement of KDB 662911 is using for calculating total power density. Total power density is summing entire spectra across corresponding frequency bins on the various outputs by computer.
2. Directional gain = $4.83\text{dBi} + 10\log(2) = 7.84\text{dBi} > 6\text{dBi}$, so the limit shall be reduced to $30 - (7.84 - 6) = 28.16\text{dBm}$.
3. Refer to section 3.3 for duty cycle spectrum plot.

802.11n (HT20)

TX chain	Chan.	Freq. (MHz)	PSD W/O Duty Factor		10 log (N=2) dB	Duty Factor (dB)	Total PSD With Duty Factor (dBm/500kHz)	Limit (dBm/500kHz)	Pass / Fail
			(dBm/300kHz)	(dBm/500kHz)					
0	149	5745	-10.57	-8.35	3.01	0.22	-5.12	28.16	Pass
	157	5785	-13.15	-10.93	3.01	0.22	-7.70	28.16	Pass
	165	5825	-14.82	-12.60	3.01	0.22	-9.37	28.16	Pass
1	149	5745	-10.30	-8.08	3.01	0.22	-4.85	28.16	Pass
	157	5785	-13.32	-11.10	3.01	0.22	-7.87	28.16	Pass
	165	5825	-14.66	-12.44	3.01	0.22	-9.21	28.16	Pass

Note:

1. Method 1 of power density measurement of KDB 662911 is using for calculating total power density. Total power density is summing entire spectra across corresponding frequency bins on the various outputs by computer.
2. Directional gain = $4.83\text{dBi} + 10\log(2) = 7.84\text{dBi} > 6\text{dBi}$, so the limit shall be reduced to $30 - (7.84 - 6) = 28.16\text{dBm}$.
3. Refer to section 3.3 for duty cycle spectrum plot.

802.11n (HT40)

TX chain	Chan.	Freq. (MHz)	PSD W/O Duty Factor		10 log (N=2) dB	Duty Factor (dB)	Total PSD With Duty Factor (dBm/500kHz)	Limit (dBm/500kHz)	Pass / Fail
			(dBm/300kHz)	(dBm/500kHz)					
0	151	5755	-12.50	-10.28	3.01	0.30	-6.97	28.16	Pass
	159	5795	-14.58	-12.36	3.01	0.30	-9.05	28.16	Pass
1	151	5755	-13.02	-10.80	3.01	0.30	-7.49	28.16	Pass
	159	5795	-15.15	-12.93	3.01	0.30	-9.62	28.16	Pass

Note:

- Method 1 of power density measurement of KDB 662911 is using for calculating total power density. Total power density is summing entire spectra across corresponding frequency bins on the various outputs by computer.
- Directional gain = $4.83\text{dBi} + 10\log(2) = 7.84\text{dBi} > 6\text{dBi}$, so the limit shall be reduced to $30 - (7.84 - 6) = 28.16\text{dBm}$.
- Refer to section 3.3 for duty cycle spectrum plot.

802.11ac (VHT80)

TX chain	Chan.	Freq. (MHz)	PSD W/O Duty Factor		10 log (N=2) dB	Duty Factor (dB)	Total PSD With Duty Factor (dBm/500kHz)	Limit (dBm/500kHz)	Pass / Fail
			(dBm/300kHz)	(dBm/500kHz)					
0	155	5775	-15.16	-12.94	3.01	0.71	-9.22	28.16	Pass
1	155	5775	-15.84	-13.62	3.01	0.71	-9.90	28.16	Pass

Note:

- Method 1 of power density measurement of KDB 662911 is using for calculating total power density. Total power density is summing entire spectra across corresponding frequency bins on the various outputs by computer.
- Directional gain = $4.83\text{dBi} + 10\log(2) = 7.84\text{dBi} > 6\text{dBi}$, so the limit shall be reduced to $30 - (7.84 - 6) = 28.16\text{dBm}$.
- Refer to section 3.3 for duty cycle spectrum plot.

Spectrum Plot of Worst Value

802.11a

802.11n (HT20)

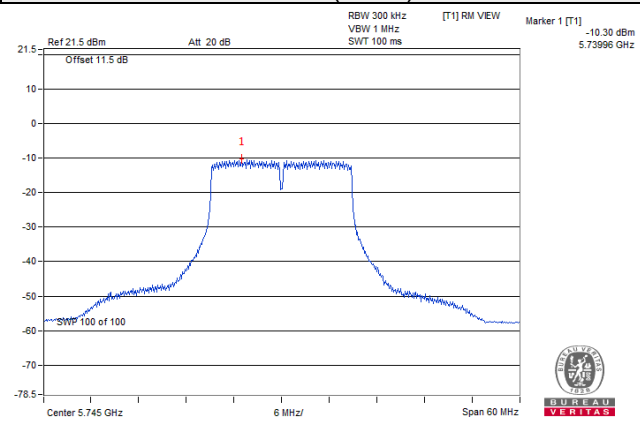
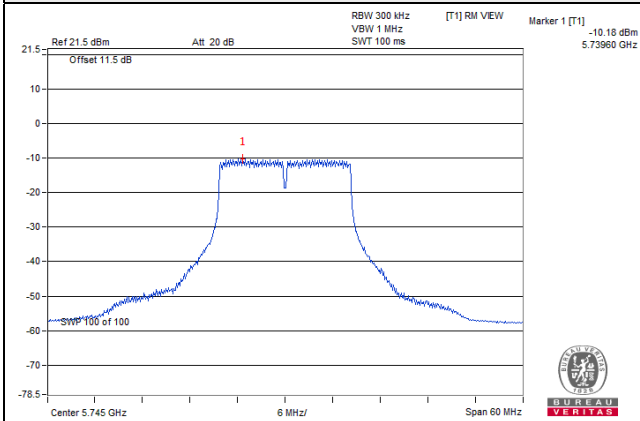

802.11n (HT40)

802.11ac (VHT80)

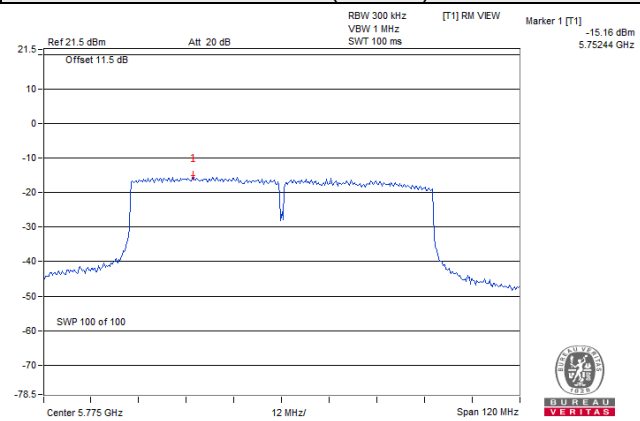
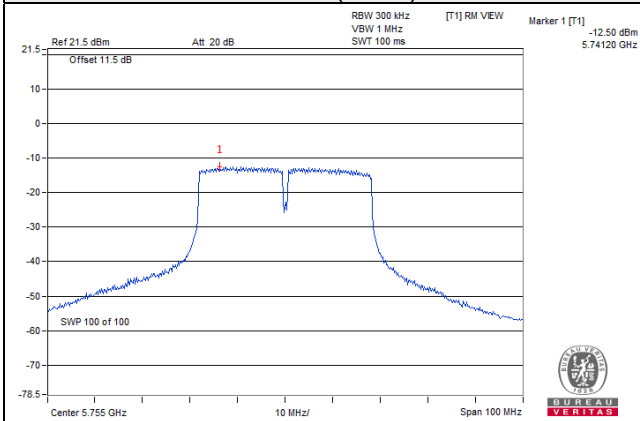

4.6 Frequency Stability

4.6.1 Limits of Frequency Stability Measurement

The frequency of the carrier signal shall be maintained within band of operation

4.6.2 Test Setup

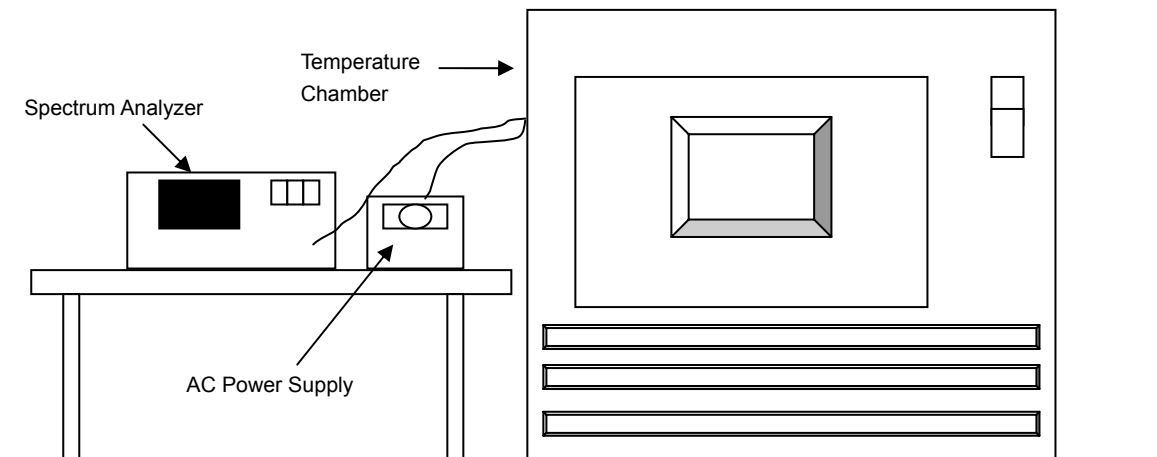

4.6.3 Test Instruments

Refer to section 4.1.2 to get information of above instrument.

4.6.4 Test Procedure

- The EUT was placed inside the environmental test chamber and powered by nominal AC voltage.
- Turn the EUT on and couple its output to a spectrum analyzer.
- Turn the EUT off and set the chamber to the highest temperature specified.
- Allow sufficient time (approximately 30 min) for the temperature of the chamber to stabilize, turn the EUT on and measure the operating frequency after 2, 5, and 10 minutes.
- Repeat step 2 and 3 with the temperature chamber set to the lowest temperature.
- The test chamber was allowed to stabilize at +20 degree C for a minimum of 30 minutes. The supply voltage was then adjusted on the EUT from 85% to 115% and the frequency record.

4.6.5 Deviation from Test Standard

No deviation.

4.6.6 EUT Operating Condition

Set the EUT transmit at un-modulation mode to test frequency stability.

4.6.7 Test Results

Test Mode A

Frequency Stability Versus Temp.									
Operating Frequency: 5180MHz									
Temp. (°C)	Power Supply (Vac)	0 Minute		2 Minute		5 Minute		10 Minute	
		Measured Frequency (MHz)	Result	Measured Frequency (MHz)	Result	Measured Frequency (MHz)	Result	Measured Frequency (MHz)	Result
50	120	5179.9757	PASS	5179.9779	PASS	5179.9771	PASS	5179.9764	PASS
40	120	5180.0116	PASS	5180.0118	PASS	5180.0139	PASS	5180.0145	PASS
30	120	5180.0149	PASS	5180.0153	PASS	5180.0117	PASS	5180.0154	PASS
20	120	5179.9863	PASS	5179.9825	PASS	5179.9820	PASS	5179.9853	PASS
10	120	5179.9935	PASS	5179.9960	PASS	5179.9969	PASS	5179.9981	PASS
0	120	5180.0239	PASS	5180.0195	PASS	5180.0221	PASS	5180.0200	PASS
-10	120	5179.9905	PASS	5179.9905	PASS	5179.9901	PASS	5179.9879	PASS
-20	120	5179.9788	PASS	5179.9753	PASS	5179.9772	PASS	5179.9785	PASS
-30	120	5180.0176	PASS	5180.0152	PASS	5180.0154	PASS	5180.0139	PASS

Frequency Stability Versus Voltage									
Operating Frequency: 5180MHz									
Temp. (°C)	Power Supply (Vac)	0 Minute		2 Minute		5 Minute		10 Minute	
		Measured Frequency (MHz)	Result	Measured Frequency (MHz)	Result	Measured Frequency (MHz)	Result	Measured Frequency (MHz)	Result
20	138	5179.9861	PASS	5179.9826	PASS	5179.9820	PASS	5179.9853	PASS
	120	5179.9863	PASS	5179.9825	PASS	5179.9820	PASS	5179.9853	PASS
	102	5179.9860	PASS	5179.9831	PASS	5179.9811	PASS	5179.9855	PASS

Test Mode C

Frequency Stability Versus Temp.									
Operating Frequency: 5180MHz									
Temp. (°C)	Power Supply (Vac)	0 Minute		2 Minute		5 Minute		10 Minute	
		Measured Frequency (MHz)	Result	Measured Frequency (MHz)	Result	Measured Frequency (MHz)	Result	Measured Frequency (MHz)	Result
50	120	5179.9786	PASS	5179.9803	PASS	5179.9800	PASS	5179.9807	PASS
40	120	5180.0078	PASS	5180.0047	PASS	5180.0092	PASS	5180.0093	PASS
30	120	5179.9892	PASS	5179.9877	PASS	5179.9862	PASS	5179.9892	PASS
20	120	5179.9943	PASS	5179.9972	PASS	5179.9977	PASS	5179.9970	PASS
10	120	5179.9858	PASS	5179.9861	PASS	5179.9874	PASS	5179.9852	PASS
0	120	5180.0132	PASS	5180.0135	PASS	5180.0152	PASS	5180.0173	PASS
-10	120	5180.0045	PASS	5180.0072	PASS	5180.0057	PASS	5180.0072	PASS
-20	120	5179.9774	PASS	5179.9759	PASS	5179.9774	PASS	5179.9788	PASS
-30	120	5179.9866	PASS	5179.9865	PASS	5179.9889	PASS	5179.9889	PASS

Frequency Stability Versus Voltage									
Operating Frequency: 5180MHz									
Temp. (°C)	Power Supply (Vac)	0 Minute		2 Minute		5 Minute		10 Minute	
		Measured Frequency (MHz)	Result	Measured Frequency (MHz)	Result	Measured Frequency (MHz)	Result	Measured Frequency (MHz)	Result
20	138	5179.9941	PASS	5179.9966	PASS	5179.9987	PASS	5179.9975	PASS
	120	5179.9943	PASS	5179.9972	PASS	5179.9977	PASS	5179.9970	PASS
	102	5179.9951	PASS	5179.9976	PASS	5179.9967	PASS	5179.9971	PASS

4.7 6dB Bandwidth Measurement

4.7.1 Limits of 6dB Bandwidth Measurement

The minimum of 6dB Bandwidth Measurement is 0.5MHz.

4.7.2 Test Setup

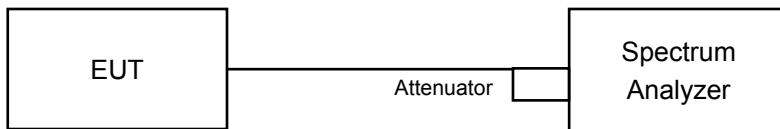

4.7.3 Test Instruments

Refer to section 4.1.2 to get information of above instrument.

4.7.4 Test Procedure

Measurement Procedure REF

- Set resolution bandwidth (RBW) = 100kHz
- Set the video bandwidth (VBW) $\geq 3 \times$ RBW, Detector = Peak.
- Trace mode = max hold.
- Sweep = auto couple.
- Measure the maximum width of the emission that is constrained by the frequencies associated with the two amplitude points (upper and lower) that are attenuated by 6 dB relative to the maximum level measured in the fundamental emission

4.7.5 Deviation from Test Standard

No deviation.

4.7.6 EUT Operating Condition

The software provided by client to enable the EUT under transmission condition continuously at lowest, middle and highest channel frequencies individually.

4.7.7 Test Results

Test Mode A

802.11a

Channel	Frequency (MHz)	6dB Bandwidth (MHz)		Minimum Limit (MHz)	Pass / Fail
		Chain 0	Chain 1		
149	5745	16.36	16.36	0.5	Pass
157	5785	16.38	16.33	0.5	Pass
165	5825	16.38	16.36	0.5	Pass

802.11n (HT20)

Channel	Frequency (MHz)	6dB Bandwidth (MHz)		Minimum Limit (MHz)	Pass / Fail
		Chain 0	Chain 1		
149	5745	17.60	17.18	0.5	Pass
157	5785	17.63	17.63	0.5	Pass
165	5825	17.64	17.62	0.5	Pass

802.11n (HT40)

Channel	Frequency (MHz)	6dB Bandwidth (MHz)		Minimum Limit (MHz)	Pass / Fail
		Chain 0	Chain 1		
151	5755	35.34	35.17	0.5	Pass
159	5795	35.31	33.98	0.5	Pass

802.11ac (VHT80)

Channel	Frequency (MHz)	6dB Bandwidth (MHz)		Minimum Limit (MHz)	Pass / Fail
		Chain 0	Chain 1		
155	5775	75.95	75.70	0.5	Pass

Spectrum Plot of Worst Value

802.11a

802.11n (HT20)

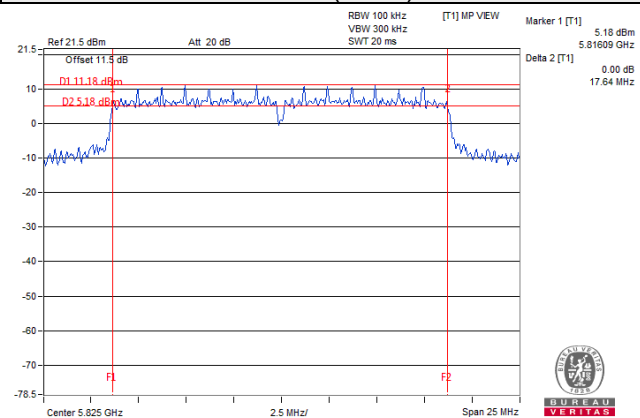
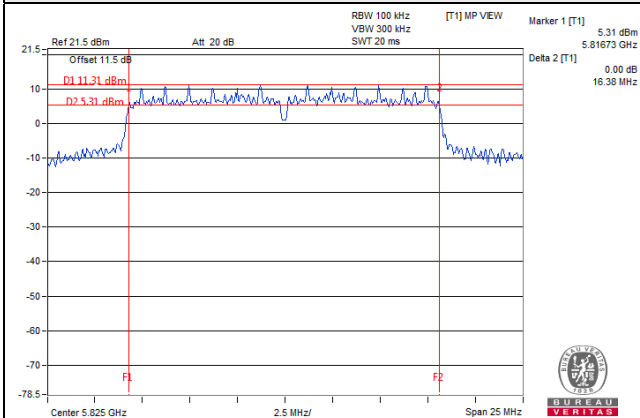

802.11n (HT40)

802.11ac (VHT80)

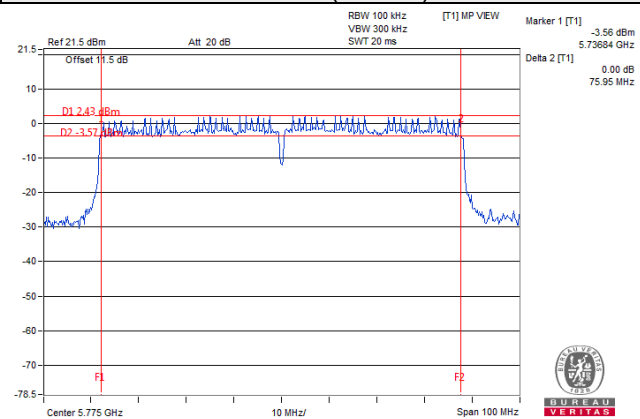
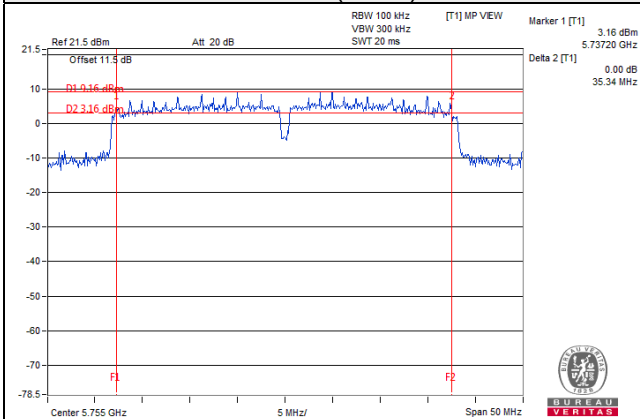

Test Mode C

802.11a

Channel	Frequency (MHz)	6dB Bandwidth (MHz)		Minimum Limit (MHz)	Pass / Fail
		Chain 0	Chain 1		
149	5745	16.38	16.40	0.5	Pass
157	5785	16.38	16.43	0.5	Pass
165	5825	16.38	16.40	0.5	Pass

802.11n (HT20)

Channel	Frequency (MHz)	6dB Bandwidth (MHz)		Minimum Limit (MHz)	Pass / Fail
		Chain 0	Chain 1		
149	5745	17.62	17.61	0.5	Pass
157	5785	17.25	17.36	0.5	Pass
165	5825	17.30	17.37	0.5	Pass

802.11n (HT40)

Channel	Frequency (MHz)	6dB Bandwidth (MHz)		Minimum Limit (MHz)	Pass / Fail
		Chain 0	Chain 1		
151	5755	35.83	35.87	0.5	Pass
159	5795	35.84	35.87	0.5	Pass

802.11ac (VHT80)

Channel	Frequency (MHz)	6dB Bandwidth (MHz)		Minimum Limit (MHz)	Pass / Fail
		Chain 0	Chain 1		
155	5775	73.34	75.90	0.5	Pass

Spectrum Plot of Worst Value

802.11a

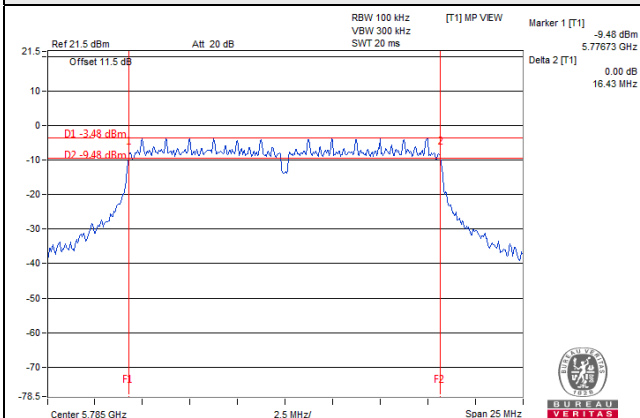

802.11n (HT20)

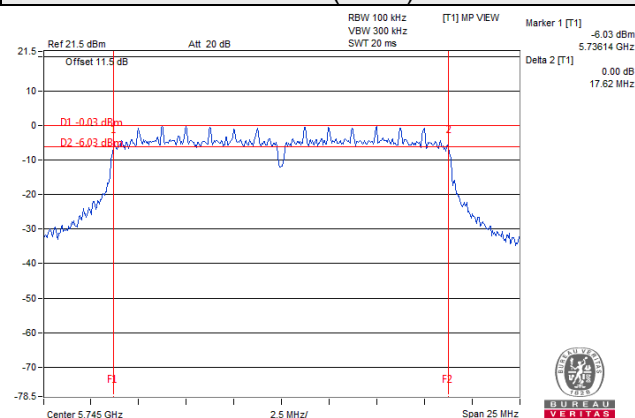

802.11n (HT40)

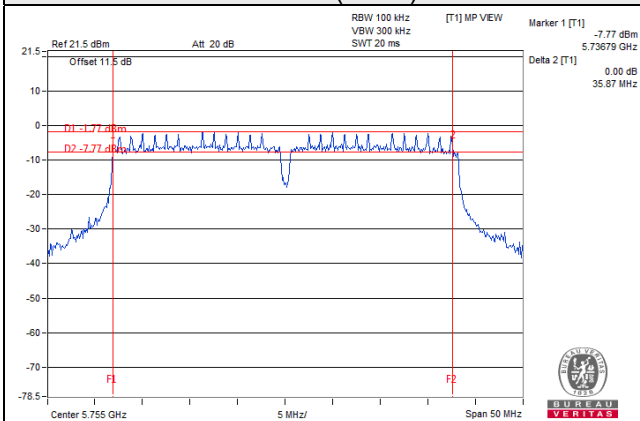

802.11ac (VHT80)

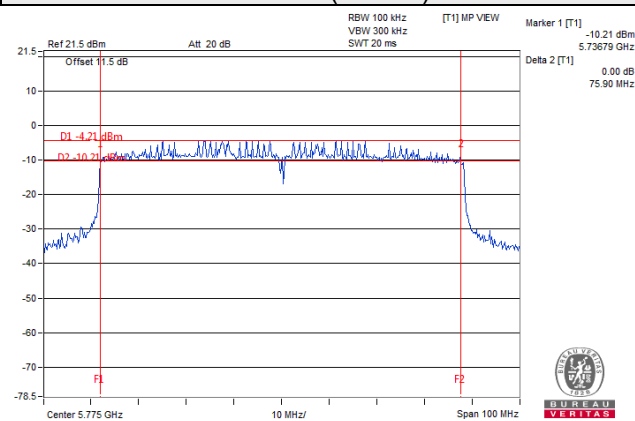

5 Pictures of Test Arrangements

Please refer to the attached file (Test Setup Photo).

Annex A- Radiated Out of Band Emission (OOBE) Measurement (For U-NII-3 band)

Test Mode A

802.11a

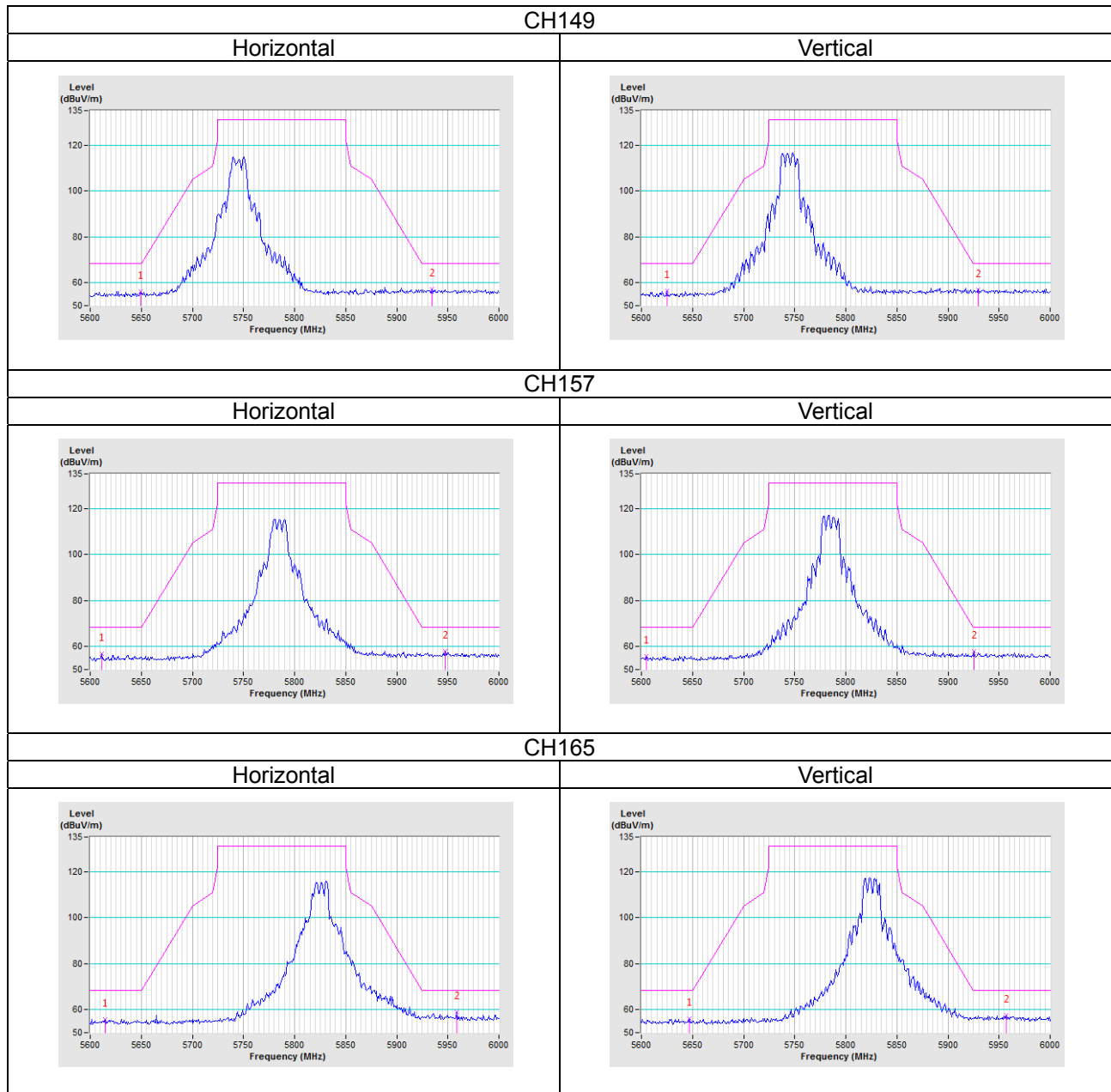

802.11n (HT20)

CH149

Horizontal

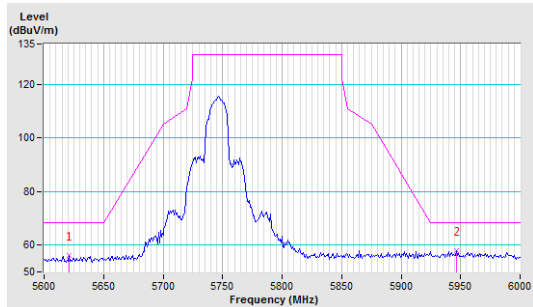

Vertical

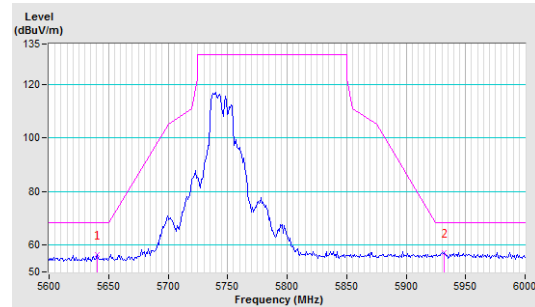

CH157

Horizontal

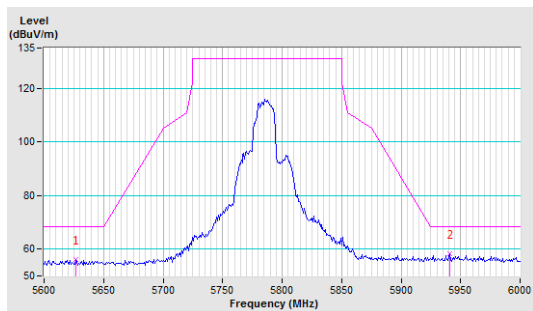

Vertical

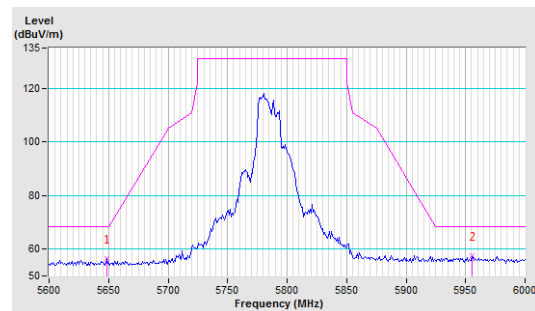

CH165

Horizontal

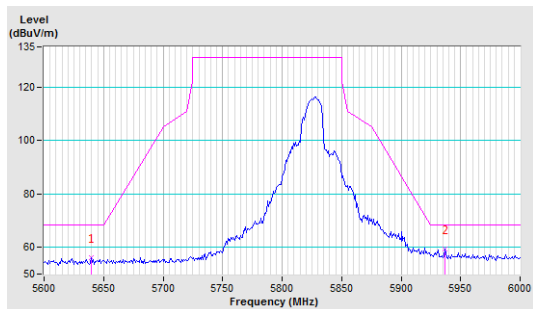

Vertical

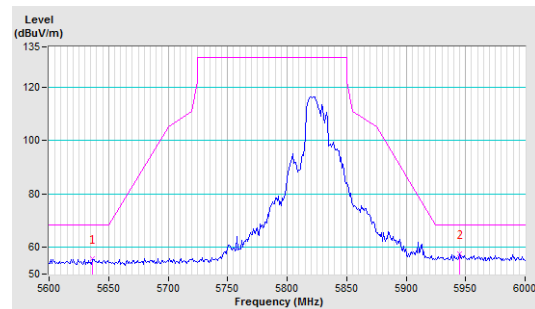

802.11n (HT40)

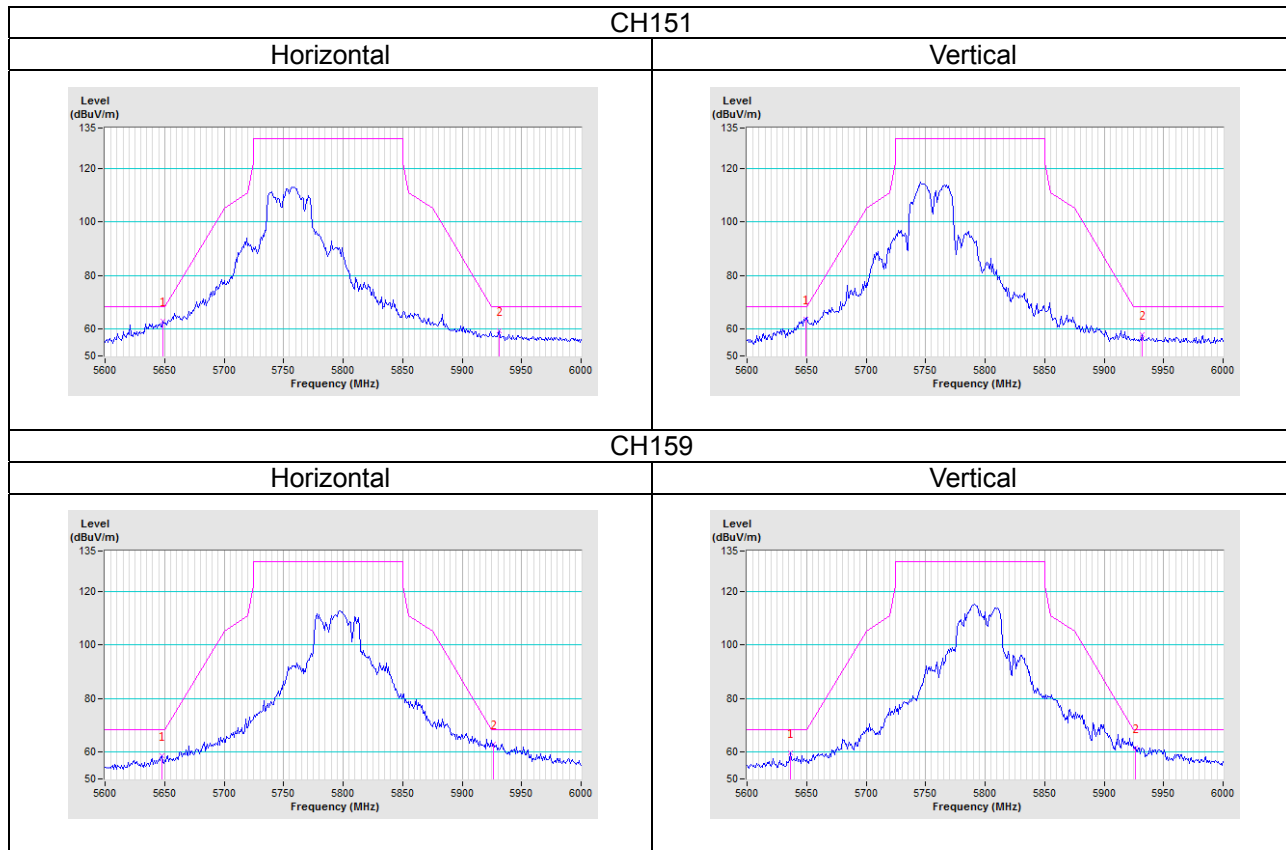

802.11ac (VHT80)

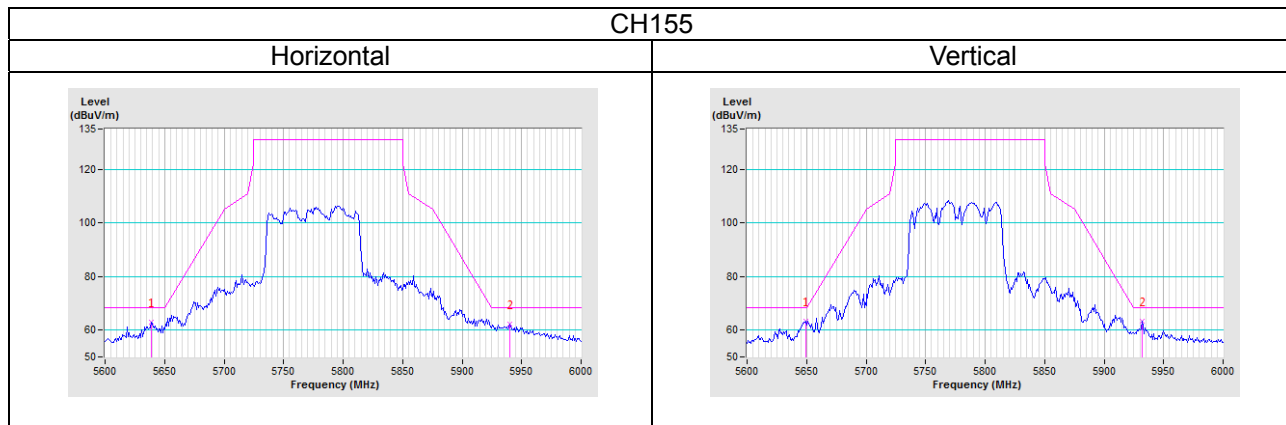

Test Mode C

802.11a

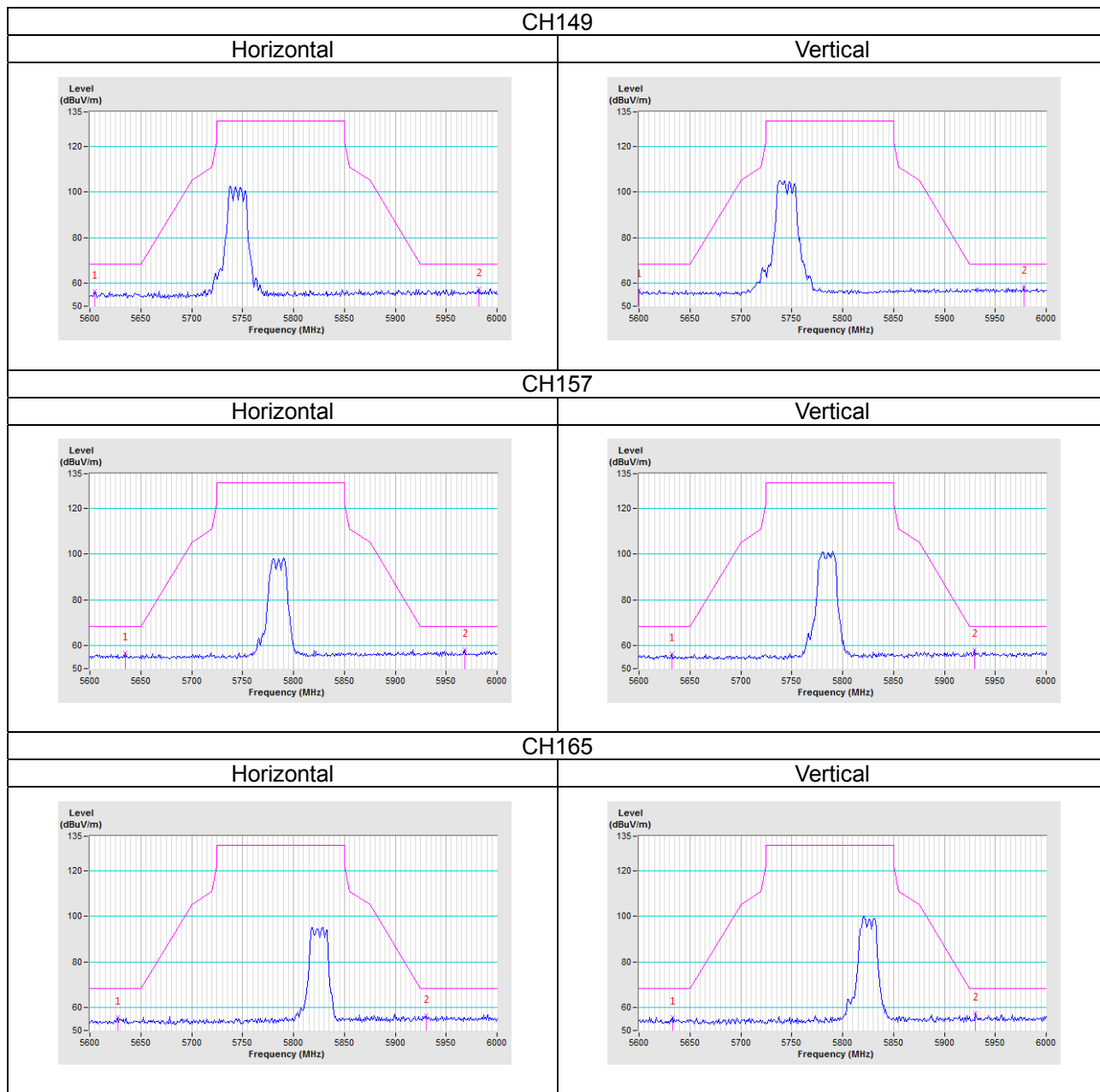

802.11n (HT20)

CH149

Horizontal

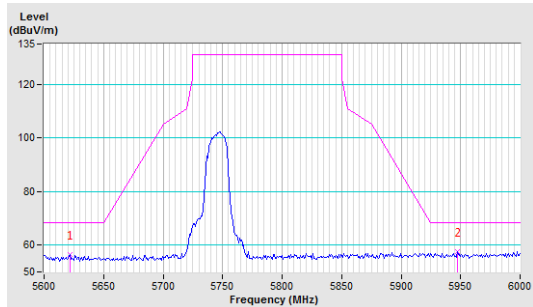

Vertical

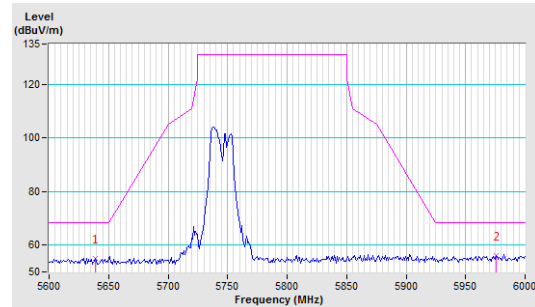

CH157

Horizontal

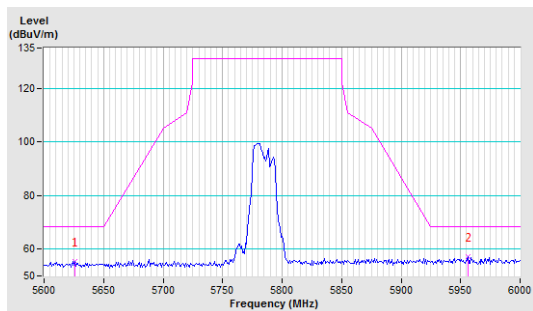

Vertical

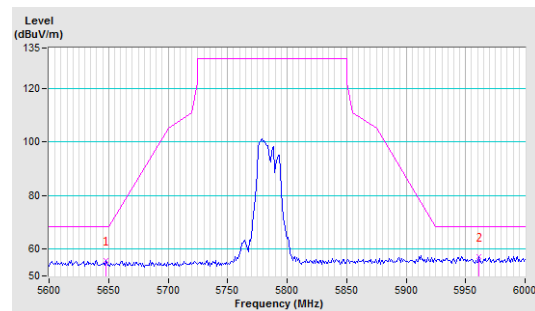

CH165

Horizontal

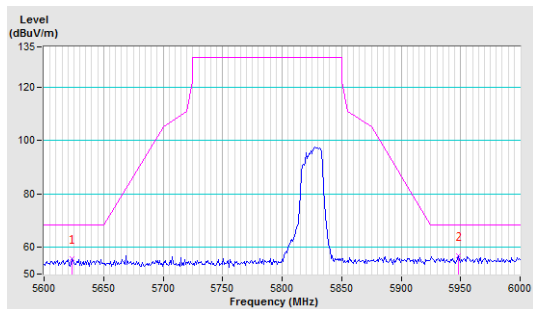

Vertical

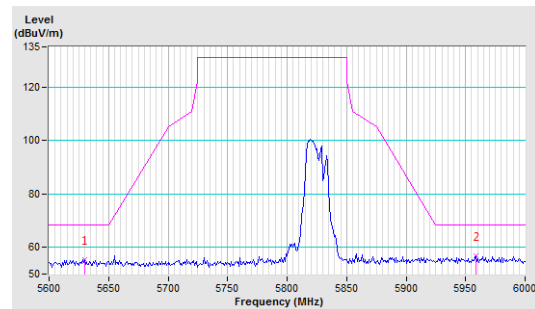

802.11n (HT40)

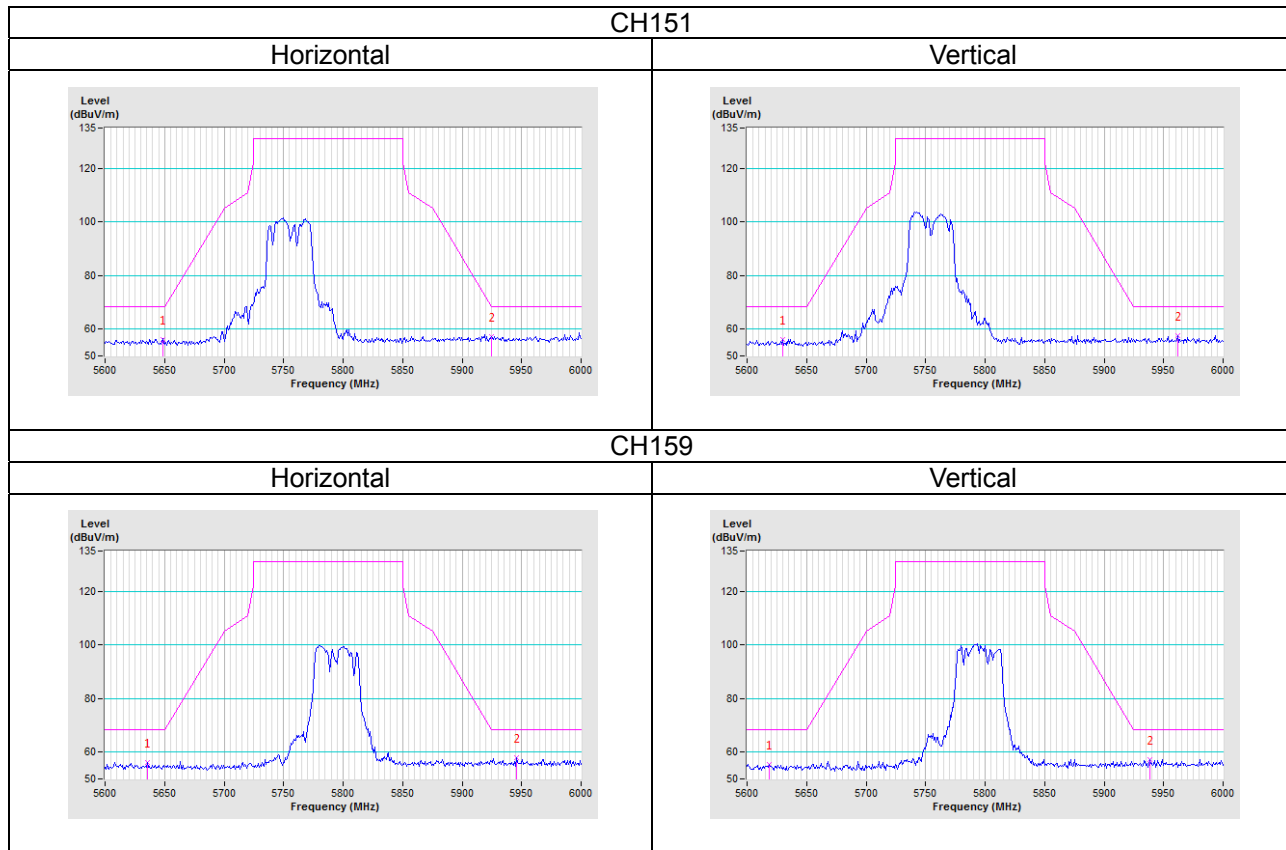

802.11ac (VHT80)

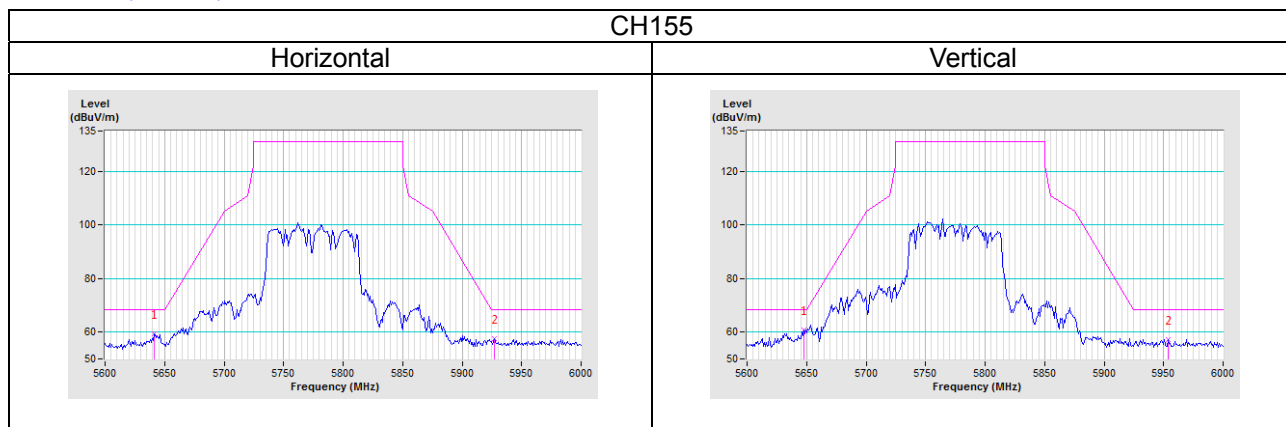

Appendix – Information on the Testing Laboratories

We, Bureau Veritas Consumer Products Services (H.K.) Ltd., Taoyuan Branch, were founded in 1988 to provide our best service in EMC, Radio, Telecom and Safety consultation. Our laboratories are FCC recognized accredited test firms and accredited and approved according to ISO/IEC 17025.

If you have any comments, please feel free to contact us at the following:

Linko EMC/RF Lab

Tel: 886-2-26052180

Fax: 886-2-26051924

Hsin Chu EMC/RF/Telecom Lab

Tel: 886-3-6668565

Fax: 886-3-6668323

Hwa Ya EMC/RF/Safety

Tel: 886-3-3183232

Fax: 886-3-3270892

Email: service.adt@tw.bureauveritas.com

Web Site: www.bureauveritas-adt.com

The address and road map of all our labs can be found in our web site also.

--- END ---