

## FCC Test Report (Class II Permissive Change)

Product Name	SpectraGuard® Access Point / Sensor
Model No	SS-300AT-C-60
FCC ID	TOR-SS300ATC60

Applicant	AirTight Networks, Inc.
Address	339 N. Bernardo Avenue, Suite #200, Mountain View, California, USA

Date of Receipt	Jul. 03, 2013
Issued Date	Nov. 12, 2013
Report No.	137146R-RFUSP05V00
Report Version	V1.0



The test results relate only to the samples tested.

The test report shall not be reproduced except in full without the written approval of Quietek Corporation.

This report must not be used to claim product endorsement by TAF or any agency of the U.S. Government

# Test Report Certification

Issued Date: Nov. 12, 2013

Report No.: 137146R-RFUSP05V00



Product Name	SpectraGuard® Access Point / Sensor
Applicant	AirTight Networks, Inc.
Address	339 N. Bernardo Avenue, Suite #200, Mountain View, California, USA
Manufacturer	DONG GUAN G-COM COMPUTER CO., LTD.
Model No.	SS-300AT-C-60
FCC ID.	TOR-SS300ATC60
EUT Rated Voltage	DC 12V
EUT Test Voltage	AC 120V/60Hz
Trade Name	AirTight
Applicable Standard	FCC CFR Title 47 Part 15 Subpart E: 2012 ANSI C63.4: 2003; ANSI C63.10: 2009, KDB 558074
Test Result	Complied

The Test Results relate only to the samples tested.

The test report shall not be reproduced except in full without the written approval of QuieTek Corporation.

This report must not be used to claim product endorsement by TAF or any agency of the U.S. Government

Documented By : Leven Huang  
(Senior Adm. Specialist / Leven Huang )

Tested By : Jack Hsu  
( Engineer / Jack Hsu)

Approved By : Vincent Lin  
( Manager / Vincent Lin )

# TABLE OF CONTENTS

Description	Page
<b>1. GENERAL INFORMATION .....</b>	<b>5</b>
1.1. EUT Description.....	5
1.2. Operational Description .....	7
1.3. Tested System Details.....	8
1.4. Configuration of tested System .....	8
1.5. EUT Exercise Software .....	8
1.6. Test Facility .....	9
<b>2. Conducted Emission.....</b>	<b>10</b>
2.1. Test Equipment.....	10
2.2. Test Setup .....	10
2.3. Limits .....	11
2.4. Test Procedure .....	11
2.5. Uncertainty .....	11
2.6. Test Result of Conducted Emission.....	12
<b>3. Maximun conducted output power .....</b>	<b>20</b>
3.1. Test Equipment.....	20
3.2. Test Setup .....	20
3.3. Limits .....	21
3.4. Test Procedur .....	21
3.5. Uncertainty .....	21
3.6. Test Result of Maximum conducted output power.....	22
<b>4. Peak Power Spectral Density.....</b>	<b>88</b>
4.1. Test Equipment.....	88
4.2. Test Setup .....	88
4.3. Limits .....	88
4.4. Test Procedure .....	89
4.5. Uncertainty .....	89
4.6. Test Result of Peak Power Spectral Density .....	90
<b>5. Peak Excursion .....</b>	<b>150</b>
5.1. Test Equipment.....	150
5.2. Test Setup .....	150
5.3. Limits .....	150
5.4. Test Procedure .....	151
5.5. Uncertainty .....	151
5.6. Test Result of Peak Excursion.....	152
<b>6. Radiated Emission.....</b>	<b>206</b>
6.1. Test Equipment.....	206
6.2. Test Setup .....	206
6.3. Limits .....	207
6.4. Test Procedure .....	208
6.5. Uncertainty .....	208
6.6. Test Result of Radiated Emission.....	209
<b>7. Band Edge .....</b>	<b>255</b>

---

7.1.	Test Equipment.....	255
7.2.	Test Setup .....	256
7.3.	Limits .....	257
7.4.	Test Procedure .....	257
7.5.	Uncertainty .....	257
7.6.	Test Result of Band Edge .....	258
<b>8.</b>	<b>Frequency Stability.....</b>	<b>312</b>
8.1.	Test Equipment.....	312
8.2.	Test Setup .....	312
8.3.	Limits .....	312
8.4.	Test Procedure .....	312
8.5.	Uncertainty .....	312
8.6.	Test Result of Frequency Stability.....	313
<b>9.</b>	<b>EMI Reduction Method During Compliance Testing .....</b>	<b>325</b>
Attachment 1:	EUT Test Photographs	
Attachment 2:	EUT Detailed Photographs	

## 1. GENERAL INFORMATION

### 1.1. EUT Description

Product Name	SpectraGuard® Access Point / Sensor
Trade Name	AirTight
FCC ID.	TOR-SS300ATC60
Model No.	SS-300AT-C-60
Frequency Range	802.11a/n-20MHz: 5260-5320MHz, 5500-5700MHz 802.11n-40MHz: 5270-5310MHz, 5510-5670MHz
Number of Channels	802.11a/n-20MHz: 12, n-40MHz: 5
Data Rate	802.11a/g: 6-54Mbps, 802.11n: up to 450Mbps
Channel Control	Auto
Type of Modulation	802.11a/n:OFDM, BPSK, QPSK, 16QAM, 64QAM
Antenna type	PIFA / Dipole
Antenna Gain	Refer to the table “Antenna List”

#### Antenna List

No.	Manufacturer	Part No.	Peak Gain	Note
1	JOYMAX	JWX-614XRSXX-361	5dBi For 5.25~5.35GHz	External Antenna (Dipole)
		JWX-614XRSXX-361	5dBi For 5.47~5.725GHz	
		JWX-614XRSXX-361		
2	MAGLAYERS	MSA-3810-2G4C1-B4	3.87dBi For 5.25~5.35GHz	Internal Antenna (PIFA)
		MSA-3810-2G4C1-B3	4.76dBi For 5.47~5.725GHz	
		MSA-3810-2G4C1-A37		

Note: The antenna of EUT is conform to FCC 15.203

## 802.11a/n-20MHz Center Working Frequency of Each Channel:

Channel	Frequency	Channel	Frequency	Channel	Frequency	Channel	Frequency
Channel 52:	5260 MHz	Channel 56:	5280 MHz	Channel 60:	5300 MHz	Channel 64:	5320 MHz
Channel 100:	5500 MHz	Channel 104:	5520 MHz	Channel 108:	5540 MHz	Channel 112:	5560 MHz
Channel 116:	5580 MHz	Channel 132:	5660 MHz	Channel 136:	5680 MHz	Channel 140:	5700 MHz

## 802.11n-40MHz Center Working Frequency of Each Channel:

Channel	Frequency	Channel	Frequency	Channel	Frequency	Channel	Frequency
Channel 54:	5270 MHz	Channel 62:	5310 MHz	Channel 102:	5510 MHz	Channel 110:	5550 MHz
Channel 134:	5670 MHz						

## Note:

1. This device is a SpectraGuard® Access Point / Sensor with a built-in two WLAN module, module 1 support 2T2R, module 2 support 3T3R technology, this report for 3T3R module.
2. Regarding to the operation frequency, the lowest, middle and highest frequency are selected to perform the test.
3. This is requesting a Class II permissive change for FCC ID: TOR-SS300ATC60. Originally granted on 09/18/2013.  
The differences are listed as below:
  - Add the frequency band from 5250-5350MHz and 5470 – 5725MHz by software.
  - All other hardware is identical with original granted.
4. Lowest and highest data rates are tested in each mode. Only worst case is shown in the report.  
Module 2: (802.11a is 6Mbps, 802.11n-20BW is 21.7Mbps and 802.11n-40BW are 45Mbps)
5. These tests were conducted on a sample of the equipment for the purpose of demonstrating compliance with Part 15 Subpart E for Unlicensed National Information Infrastructure devices.
6. The radiation measurements are performed in X, Y, Z axis positioning. Only the worst case is shown in the report.

Test Mode	Mode 1: Transmit (802.11a-6Mbps)(Dipole Antenna) Mode 2: Transmit (802.11n-20BW 21.7Mbps)(Dipole Antenna) Mode 3: Transmit (802.11n-40BW 45Mbps)(Dipole Antenna) Mode 4: Transmit (802.11a-6Mbps)(PIFA Antenna) Mode 5: Transmit (802.11n-20BW 21.7Mbps)(PIFA Antenna) Mode 6 Transmit (802.11n-40BW 45Mbps)(PIFA Antenna)
-----------	---

### 1.3. Tested System Details

The types for all equipment, plus descriptions of all cables used in the tested system (including inserted cards) are:

Product	Manufacturer	Model No.	Serial No.	Power Cord
(1) Notebook PC	DELL	PPT	N/A	Non-Shielded, 0.8m
(2) Power Adapter	DVE	DSA-15P-12 US 120150	N/A	Non-Shielded, 1.7m

Signal Cable Type		Signal cable Description
A	RJ45 Cable	Non-Shielded, 5.0m
B	RJ45 to RS-232 Cable	Non-Shielded, 5.0m
C	RJ45 Cable	Non-Shielded, 5.0m
D	Power Cable	Non-Shielded, 1.7m

### 1.4. Configuration of tested System

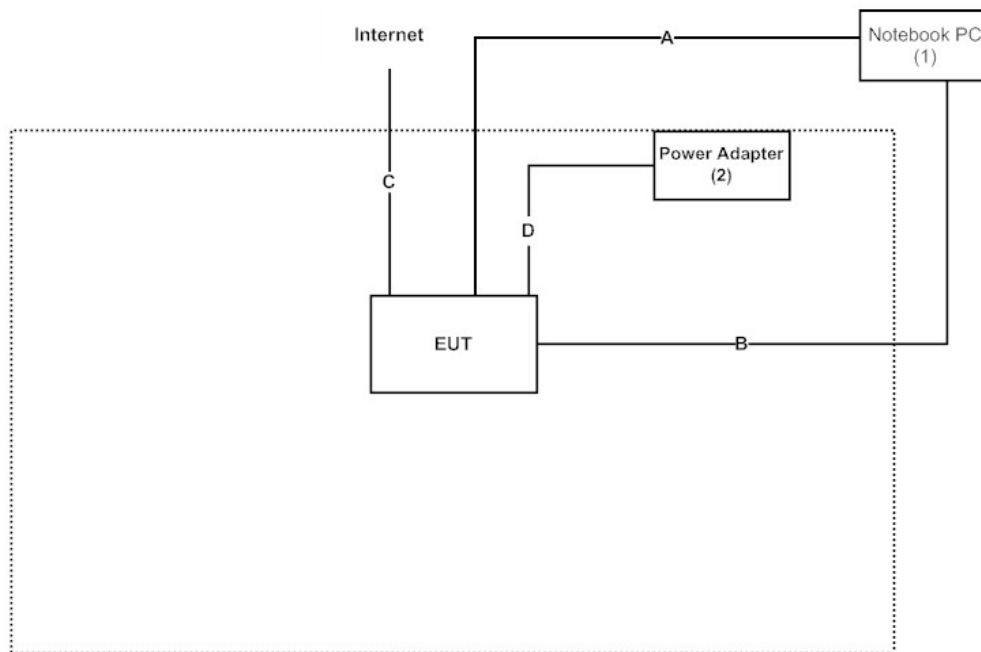

### 1.5. EUT Exercise Software

- (1) Connect EUT and Notebook via RJ45 & RS232 Cable
- (2) Execute “Art2-GUI V2.3” program on the Notebook PC.
- (3) Configure the test mode, the test channel, and the data rate.
- (4) Start the continuous transmission.
- (5) Verify that the EUT works properly.

## 1.6. Test Facility

Ambient conditions in the laboratory:

Items	Required (IEC 68-1)	Actual
Temperature (°C)	15-35	20-35
Humidity (%RH)	25-75	50-65
Barometric pressure (mbar)	860-1060	950-1000

The related certificate for our laboratories about the test site and management system can be downloaded from Quietek Corporation's Web Site : <http://tw.quietek.com/modules/myalbum/>

The address and introduction of Quietek Corporation's laboratories can be founded in our Web site : <http://www.quietek.com/>

Site Description: File on  
 Federal Communications Commission  
 FCC Engineering Laboratory  
 7435 Oakland Mills Road  
 Columbia, MD 21046  
 Registration Number: 92195

Site Name: Quietek Corporation  
 Site Address: No.5-22, Ruishukeng,  
 Linkou Dist. New Taipei City 24451,  
 Taiwan, R.O.C.  
 TEL: 886-2-8601-3788 / FAX : 886-2-8601-3789  
 E-Mail : [service@quietek.com](mailto:service@quietek.com)

FCC Accreditation Number: TW1014



## 2. Conducted Emission

### 2.1. Test Equipment

	Equipment	Manufacturer	Model No. / Serial No.	Last Cal.	Remark
X	Test Receiver	R & S	ESCS 30 / 825442/018	Sep., 2012	
X	Artificial Mains Network	R & S	ENV4200 / 848411/10	Feb., 2013	Peripherals
X	LISN	R & S	ESH3-Z5 / 825562/002	Feb., 2013	EUT
	DC LISN	Schwarzbeck	8226 / 176	Mar, 2013	EUT
X	Pulse Limiter	R & S	ESH3-Z2 / 357.8810.52	Feb., 2013	
	No.1 Shielded Room				

Note:

1. All equipments are calibrated every one year.
2. The test instruments marked by “X” are used to measure the final test results.

### 2.2. Test Setup

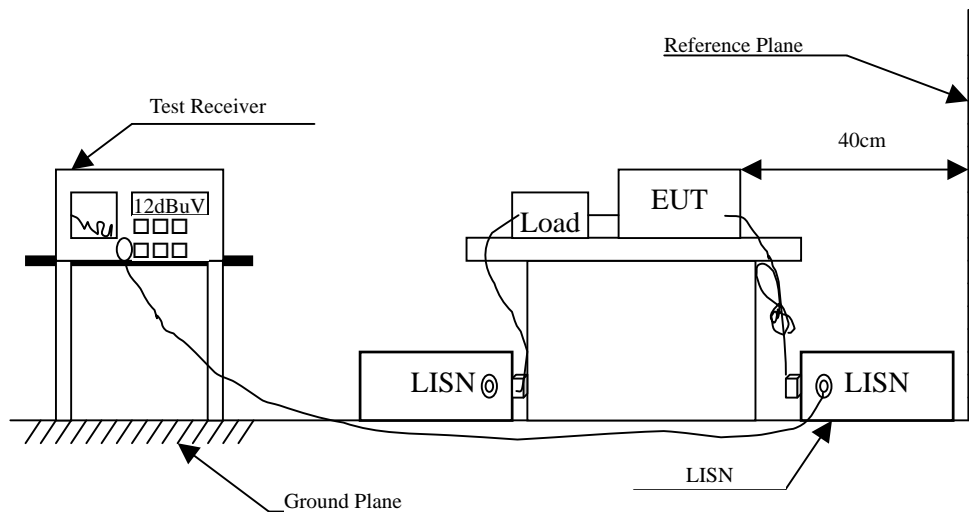

**2.3. Limits**

<b>FCC Part 15 Subpart C Paragraph 15.207 (dBuV) Limit</b>		
Frequency MHz	Limits	
	QP	AV
0.15 - 0.50	66-56	56-46
0.50-5.0	56	46
5.0 - 30	60	50

Remarks : In the above table, the tighter limit applies at the band edges.

**2.4. Test Procedure**

The EUT and simulators are connected to the main power through a line impedance stabilization network (L.I.S.N.). This provides a 50 ohm /50uH coupling impedance for the measuring equipment. The peripheral devices are also connected to the main power through a LISN that provides a 50ohm /50uH coupling impedance with 50ohm termination. (Please refers to the block diagram of the test setup and photographs.)

Both sides of A.C. line are checked for maximum conducted interference. In order to find the maximum emission, the relative positions of equipment and all of the interface cables must be changed according to ANSI C63.10: 2009 on conducted measurement.

Conducted emissions were invested over the frequency range from 0.15MHz to 30MHz using a receiver bandwidth of 9kHz.

The EUT was setup to ANSI C63.10, 2009; tested to DTS test procedure of FCC KDB-789033 for compliance to FCC 47CFR Subpart E requirements.

**2.5. Uncertainty**

± 2.26 dB

## 2.6. Test Result of Conducted Emission

Product : SpectraGuard® Access Point / Sensor  
 Test Item : Conducted Emission Test  
 Power Line : Line 1  
 Test Mode : Mode 3: Transmit (802.11n-40BW 45Mbps)(Dipole Antenna) (5270MHz)

Frequency MHz	Correct Factor dB	Reading Level dBuV	Measurement Level dBuV	Margin dB	Limit dBuV
<b>LINE 1</b>					
<b>Quasi-Peak</b>					
0.166	9.943	39.220	49.163	-16.380	65.543
0.283	9.879	30.500	40.379	-21.821	62.200
0.341	9.869	27.180	37.049	-23.494	60.543
0.517	9.851	17.050	26.901	-29.099	56.000
1.123	9.770	19.390	29.160	-26.840	56.000
11.064	10.200	33.680	43.880	-16.120	60.000
<b>Average</b>					
0.166	9.943	13.560	23.503	-32.040	55.543
0.283	9.879	9.670	19.549	-32.651	52.200
0.341	9.869	20.460	30.329	-20.214	50.543
0.517	9.851	7.550	17.401	-28.599	46.000
1.123	9.770	9.770	19.540	-26.460	46.000
11.064	10.200	26.330	36.530	-13.470	50.000

Note:

1. All Reading Levels are Quasi-Peak and average value.
2. “■” means the worst emission level.
3. Measurement Level = Reading Level + Correct Factor

Product : SpectraGuard® Access Point / Sensor  
 Test Item : Conducted Emission Test  
 Power Line : Line 2  
 Test Mode : Mode 3: Transmit (802.11n-40BW 45Mbps)(Dipole Antenna) (5270MHz)

Frequency MHz	Correct Factor dB	Reading Level dBuV	Measurement Level dBuV	Margin dB	Limit dBuV
<b>LINE 2</b>					
<b>Quasi-Peak</b>					
0.177	9.785	39.650	49.435	-15.794	65.229
0.267	9.754	32.940	42.694	-19.963	62.657
0.298	9.750	30.250	40.000	-21.771	61.771
0.377	9.763	23.920	33.683	-25.831	59.514
0.443	9.760	20.630	30.390	-27.239	57.629
11.244	10.080	27.990	38.070	-21.930	60.000
<b>Average</b>					
0.177	9.785	12.670	22.455	-32.774	55.229
0.267	9.754	6.450	16.204	-36.453	52.657
0.298	9.750	7.020	16.770	-35.001	51.771
0.377	9.763	3.890	13.653	-35.861	49.514
0.443	9.760	2.890	12.650	-34.979	47.629
11.244	10.080	18.960	29.040	-20.960	50.000

Note:

1. All Reading Levels are Quasi-Peak and average value.
2. "■" means the worst emission level.
3. Measurement Level = Reading Level + Correct Factor

Product : SpectraGuard® Access Point / Sensor  
 Test Item : Conducted Emission Test  
 Power Line : Line 1  
 Test Mode : Mode 3: Transmit (802.11n-40BW 45Mbps)(Dipole Antenna) (5550MHz)

Frequency MHz	Correct Factor dB	Reading Level dBuV	Measurement Level dBuV	Margin dB	Limit dBuV
<b>LINE 1</b>					
<b>Quasi-Peak</b>					
0.181	9.928	37.450	47.378	-17.736	65.114
0.212	9.904	35.610	45.514	-18.715	64.229
0.244	9.900	31.470	41.370	-21.944	63.314
0.302	9.872	27.320	37.192	-24.465	61.657
0.486	9.859	16.130	25.989	-30.411	56.400
11.380	10.230	33.550	43.780	-16.220	60.000
<b>Average</b>					
0.181	9.928	11.530	21.458	-33.656	55.114
0.212	9.904	9.050	18.954	-35.275	54.229
0.244	9.900	10.070	19.970	-33.344	53.314
0.302	9.872	15.780	25.652	-26.005	51.657
0.486	9.859	7.560	17.419	-28.981	46.400
11.380	10.230	26.540	36.770	-13.230	50.000

Note:

1. All Reading Levels are Quasi-Peak and average value.
2. "■" means the worst emission level.
3. Measurement Level = Reading Level + Correct Factor

Product : SpectraGuard® Access Point / Sensor  
 Test Item : Conducted Emission Test  
 Power Line : Line 2  
 Test Mode : Mode 3: Transmit (802.11n-40BW 45Mbps)(Dipole Antenna) (5550MHz)

Frequency MHz	Correct Factor dB	Reading Level dBuV	Measurement Level dBuV	Margin dB	Limit dBuV
<b>LINE 2</b>					
<b>Quasi-Peak</b>					
0.267	9.754	29.840	39.594	-23.063	62.657
0.373	9.761	22.750	32.511	-27.118	59.629
0.466	9.763	17.160	26.923	-30.048	56.971
0.861	9.770	16.170	25.940	-30.060	56.000
1.474	9.800	13.280	23.080	-32.920	56.000
11.302	10.080	27.740	37.820	-22.180	60.000
<b>Average</b>					
0.267	9.754	5.370	15.124	-37.533	52.657
0.373	9.761	2.580	12.341	-37.288	49.629
0.466	9.763	-0.330	9.433	-37.538	46.971
0.861	9.770	5.080	14.850	-31.150	46.000
1.474	9.800	3.270	13.070	-32.930	46.000
11.302	10.080	18.870	28.950	-21.050	50.000

Note:

1. All Reading Levels are Quasi-Peak and average value.
2. "■" means the worst emission level.
3. Measurement Level = Reading Level + Correct Factor

Product : SpectraGuard® Access Point / Sensor  
 Test Item : Conducted Emission Test  
 Power Line : Line 1  
 Test Mode : Mode 6 Transmit (802.11n-40BW 45Mbps)(PIFA Antenna) (5270MHz)

Frequency MHz	Correct Factor dB	Reading Level dBuV	Measurement Level dBuV	Margin dB	Limit dBuV
<b>LINE 1</b>					
<b>Quasi-Peak</b>					
0.154	9.955	41.790	51.745	-14.141	65.886
0.177	9.932	38.630	48.562	-16.667	65.229
0.216	9.902	34.920	44.822	-19.292	64.114
0.298	9.873	27.660	37.533	-24.238	61.771
0.396	9.869	19.260	29.129	-29.842	58.971
11.013	10.200	33.580	43.780	-16.220	60.000
<b>Average</b>					
0.154	9.955	12.250	22.205	-33.681	55.886
0.177	9.932	13.250	23.182	-32.047	55.229
0.216	9.902	6.690	16.592	-37.522	54.114
0.298	9.873	11.400	21.273	-30.498	51.771
0.396	9.869	2.980	12.849	-36.122	48.971
11.013	10.200	26.280	36.480	-13.520	50.000

Note:

1. All Reading Levels are Quasi-Peak and average value.
2. "■" means the worst emission level.
3. Measurement Level = Reading Level + Correct Factor

Product : SpectraGuard® Access Point / Sensor  
 Test Item : Conducted Emission Test  
 Power Line : Line 2  
 Test Mode : Mode 6 Transmit (802.11n-40BW 45Mbps)(PIFA Antenna) (5270MHz)

Frequency MHz	Correct Factor dB	Reading Level dBuV	Measurement Level dBuV	Margin dB	Limit dBuV
<b>LINE 2</b>					
<b>Quasi-Peak</b>					
0.158	9.809	38.730	48.539	-17.232	65.771
0.220	9.750	31.920	41.670	-22.330	64.000
0.310	9.750	24.900	34.650	-26.779	61.429
0.357	9.760	21.410	31.170	-28.916	60.086
0.505	9.770	12.990	22.760	-33.240	56.000
11.314	10.080	27.700	37.780	-22.220	60.000
<b>Average</b>					
0.158	9.809	9.230	19.039	-36.732	55.771
0.220	9.750	3.460	13.210	-40.790	54.000
0.310	9.750	10.260	20.010	-31.419	51.429
0.357	9.760	0.740	10.500	-39.586	50.086
0.505	9.770	0.200	9.970	-36.030	46.000
11.314	10.080	18.870	28.950	-21.050	50.000

Note:

1. All Reading Levels are Quasi-Peak and average value.
2. "■" means the worst emission level.
3. Measurement Level = Reading Level + Correct Factor



Product : SpectraGuard® Access Point / Sensor  
 Test Item : Conducted Emission Test  
 Power Line : Line 1  
 Test Mode : Mode 6 Transmit (802.11n-40BW 45Mbps)(PIFA Antenna) (5550MHz)

Frequency MHz	Correct Factor dB	Reading Level dBuV	Measurement Level dBuV	Margin dB	Limit dBuV
<b>LINE 1</b>					
<b>Quasi-Peak</b>					
0.427	9.861	17.180	27.041	-31.045	58.086
0.576	9.821	19.220	29.041	-26.959	56.000
0.849	9.770	20.320	30.090	-25.910	56.000
1.451	9.750	19.170	28.920	-27.080	56.000
7.627	9.970	20.890	30.860	-29.140	60.000
11.119	10.210	33.620	43.830	-16.170	60.000
<b>Average</b>					
0.427	9.861	3.270	13.131	-34.955	48.086
0.576	9.821	8.340	18.161	-27.839	46.000
0.849	9.770	9.840	19.610	-26.390	46.000
1.451	9.750	10.780	20.530	-25.470	46.000
7.627	9.970	13.480	23.450	-26.550	50.000
11.119	10.210	26.400	36.610	-13.390	50.000

Note:

1. All Reading Levels are Quasi-Peak and average value.
2. "■" means the worst emission level.
3. Measurement Level = Reading Level + Correct Factor

Product : SpectraGuard® Access Point / Sensor  
 Test Item : Conducted Emission Test  
 Power Line : Line 2  
 Test Mode : Mode 6 Transmit (802.11n-40BW 45Mbps)(PIFA Antenna) (5550MHz)

Frequency MHz	Correct Factor dB	Reading Level dBuV	Measurement Level dBuV	Margin dB	Limit dBuV
<b>LINE 2</b>					
<b>Quasi-Peak</b>					
0.177	9.785	37.640	47.425	-17.804	65.229
0.298	9.750	26.380	36.130	-25.641	61.771
0.576	9.760	14.210	23.970	-32.030	56.000
0.896	9.776	14.800	24.576	-31.424	56.000
1.529	9.800	12.570	22.370	-33.630	56.000
11.650	10.100	27.190	37.290	-22.710	60.000
<b>Average</b>					
0.177	9.785	12.280	22.065	-33.164	55.229
0.298	9.750	5.410	15.160	-36.611	51.771
0.576	9.760	2.310	12.070	-33.930	46.000
0.896	9.776	3.680	13.456	-32.544	46.000
1.529	9.800	2.080	11.880	-34.120	46.000
11.650	10.100	18.320	28.420	-21.580	50.000

Note:

1. All Reading Levels are Quasi-Peak and average value.
2. "■" means the worst emission level.
3. Measurement Level = Reading Level + Correct Factor

### 3. Maximun conducted output power

#### 3.1. Test Equipment

	Equipment	Manufacturer	Model No./Serial No.	Last Cal.
X	Power Meter	Anritsu	ML2495A/6K00003357	May, 2013
X	Power Sensor	Anritsu	MA2411B/0738448	Jun, 2013
X	Spectrum Analyzer	Agilent	N9010A / MY48030495	Apr., 2013

Note:

1. All equipments are calibrated with traceable calibrations. Each calibration is traceable to the national or international standards.
2. The test instruments marked with “X” are used to measure the final test results.

#### 3.2. Test Setup

##### 26dBc Occupied Bandwidth

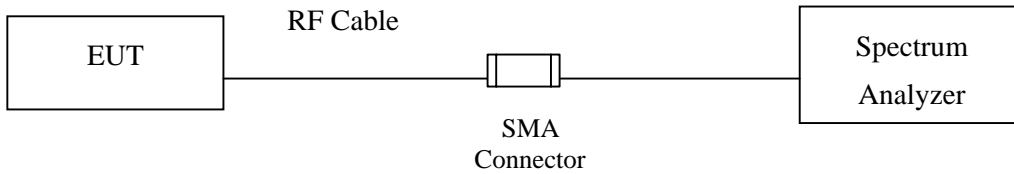

##### Conduction Power Measurement

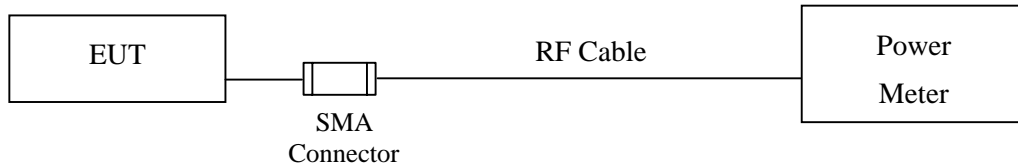

### 3.3. Limits

- (1) For the band 5.15-5.25 GHz, the maximum conducted output power over the frequency band of operation shall not exceed the lesser of 50 mW or  $4 \text{ dBm} + 10\log B$ , where B is the 26-dB emission bandwidth in MHz. If transmitting antenna of directional gain greater than 6 dBi are used, the peak transmit power shall be reduced by the amount in dB that directional gain of the antenna exceeds 6 dBi.
- (2) For the band 5.25-5.35 GHz, the maximum conducted output power over the frequency band of operation shall not exceed the lesser of 250 mW or  $11 \text{ dBm} + 10\log B$ , where B is the 26-dB emission bandwidth in MHz. If transmitting antenna of directional gain greater than 6 dBi are used, the peak transmit power shall be reduced by the amount in dB that directional gain of the antenna exceeds 6 dBi.
- (3) For the band 5.725-5.825 GHz, the maximum conducted output power over the frequency band of operation shall not exceed the lesser of 1W or  $17 \text{ dBm} + 10\log B$ , where B is the 26-dB emission bandwidth in MHz. If transmitting antenna of directional gain greater than 6 dBi are used, the peak transmit power shall be reduced by the amount in dB that directional gain of the antenna exceeds 6 dBi.

### 3.4. Test Procedur

As an alternative to FCC KDB-789033, the EUT maximum conducted output power was measured with an average power meter employing a video bandwidth greater than 6dB BW of the emission under test. Maximum conducted output power was read directly from the meter across all data rates, and across three channels within each sub-band. Special care was used to make sure that the EUT was transmitting in continuous mode. This method exceeds the limitations of FCC KDB-789033, and provides more accurate measurements.

The Maximum conducted output power using KDB 789033 section E)3)b) Method PM-G (Measurement using a gated RF average power meter).

### 3.5. Uncertainty

$\pm 1.27 \text{ dB}$

### 3.6. Test Result of Maximum conducted output power

Product : SpectraGuard® Access Point / Sensor  
 Test Item : Maximum conducted output power  
 Test Site : No.3 OATS  
 Test Mode : Mode 1: Transmit (802.11a-6Mbps)(Dipole Antenna)

#### CHAIN A

Cable loss=1dB		Maximum conducted output power								
Channel No.	Frequency (MHz)	Data Rate (Mbps)								Required Limit
		6	9	12	18	24	36	48	54	
		Measurement Level (dBm)								
52	5260	14.62	--	--	--	--	--	--	--	<24dBm
60	5300	15.42	15.3	15.18	15.06	14.94	14.82	14.7	14.58	<24dBm
64	5320	15.47	--	--	--	--	--	--	--	<24dBm
100	5500	13.8	--	--	--	--	--	--	--	<24dBm
116	5580	15.7	15.59	15.44	15.32	15.19	15.06	14.93	14.80	<24dBm
140	5700	14.51	--	--	--	--	--	--	--	<24dBm

Note: 1.Maximum conducted output power Value =Reading value on average power meter + cable loss

#### CHAIN B

Cable loss=1dB		Maximum conducted output power								
Channel No.	Frequency (MHz)	Data Rate (Mbps)								Required Limit
		6	9	12	18	24	36	48	54	
		Measurement Level (dBm)								
52	5260	13.27	--	--	--	--	--	--	--	<24dBm
60	5300	12.38	12.21	12.07	11.91	11.755	11.6	11.445	11.29	<24dBm
64	5320	12.46	--	--	--	--	--	--	--	<24dBm
100	5500	12.32	--	--	--	--	--	--	--	<24dBm
116	5580	12.55	12.41	12.27	12.13	11.99	11.85	11.71	11.57	<24dBm
140	5700	12.6	--	--	--	--	--	--	--	<24dBm

Note: 1.Maximum conducted output power Value =Reading value on average power meter + cable loss

**CHAIN C**

Cable loss=1dB		Maximum conducted output power								
Channel No.	Frequency (MHz)	Data Rate (Mbps)								Required Limit
		6	9	12	18	24	36	48	54	
		Measurement Level (dBm)								
52	5260	12.77	--	--	--	--	--	--	--	<24dBm
60	5300	14.22	14.1	13.94	13.81	13.67	13.53	13.39	13.25	<24dBm
64	5320	12.49	--	--	--	--	--	--	--	<24dBm
100	5500	13.88	--	--	--	--	--	--	--	<24dBm
116	5580	14.08	13.94	13.77	13.62	13.47	13.31	13.16	13	<24dBm
140	5700	14.4	--	--	--	--	--	--	--	<24dBm

Note: 1. Maximum conducted output power Value = Reading value on average power meter + cable loss

**Maximum conducted output power Measurement:**
**(CHAIN A+ B+C)**

Channel Number	Frequency (MHz)	26dB Bandwidth (MHz)	Chain A Power (dBm)	Chain B Power (dBm)	Chain C Power (dBm)	Output Power (dBm)	Output Power Limit	
							(dBm)	dBm+10log(BW)
52	5260	21.600	14.62	13.27	12.77	18.40	24	24.34
60	5300	21.600	15.42	12.38	14.22	18.95	24	24.34
64	5320	20.700	15.47	12.46	12.49	18.49	24	24.16
100	5500	21.550	13.80	12.32	13.88	18.16	24	24.33
116	5580	21.050	15.70	12.55	14.08	19.07	24	24.23
140	5700	21.300	14.51	12.60	14.40	18.69	24	24.28

Note:

1. Power Output Value = Reading value on average power meter + cable loss
2. Output Power (dBm) = 10LOG (Chain A Power (mW)+ Chain B Power (mW))
3. 26 dB Bandwidth is the bandwidth of chain A or chain B or chain C whichever is less bandwidth, output power limitation is more stringent.

26dBc Occupied Bandwidth:  
Channel 52: CHAIN A

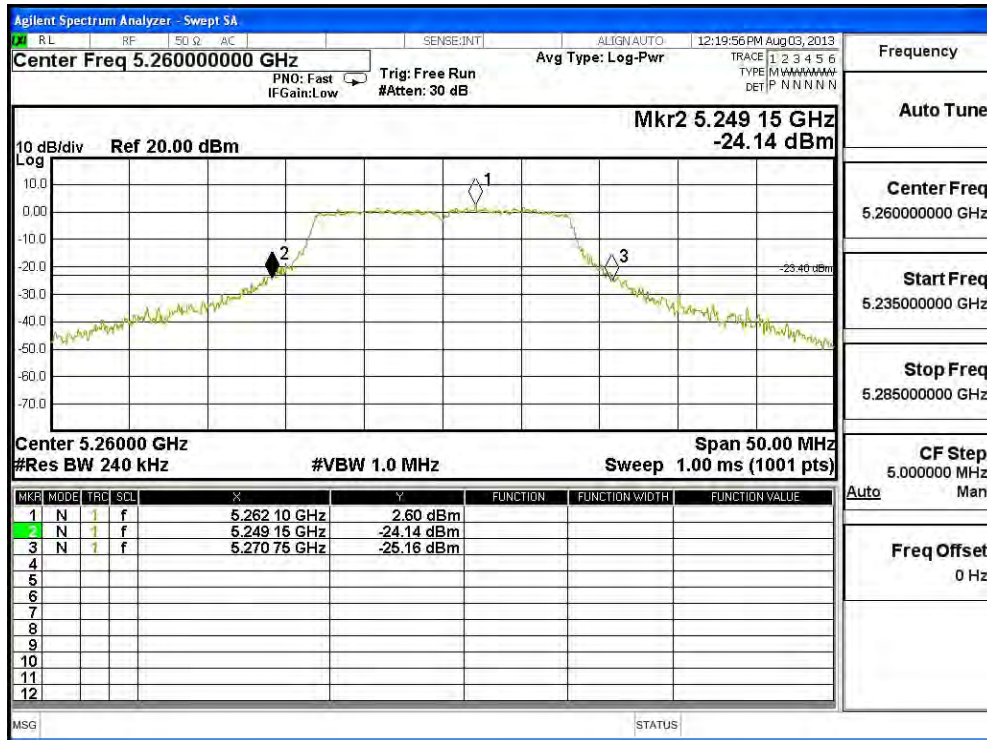

Channel 60: CHAIN A

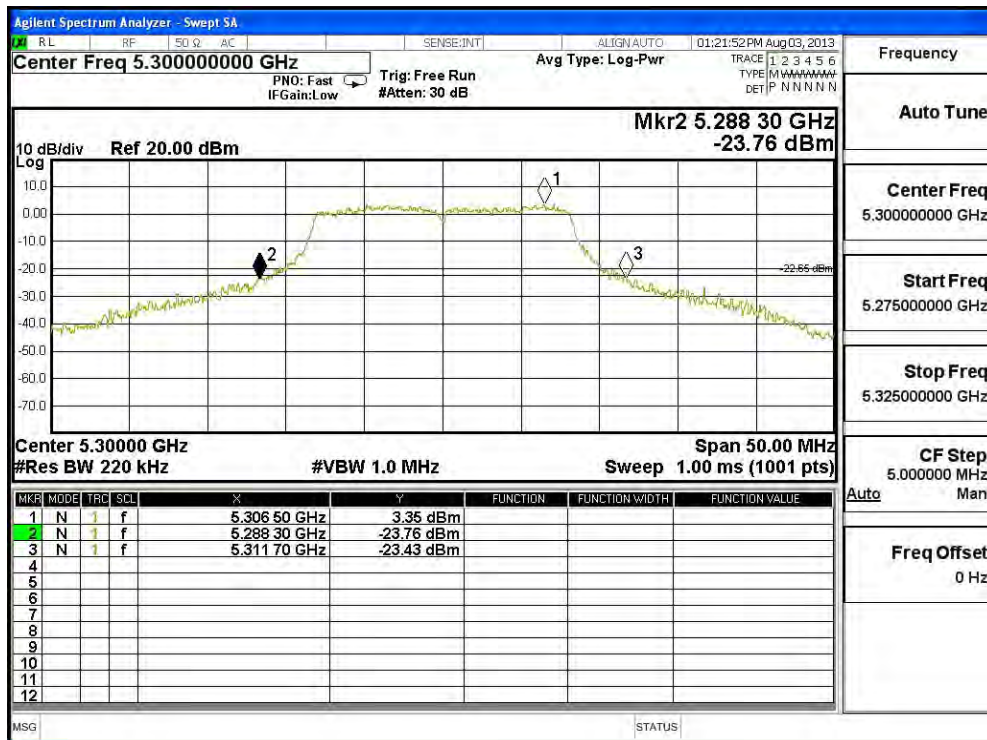

**Channel 64: CHAIN A**

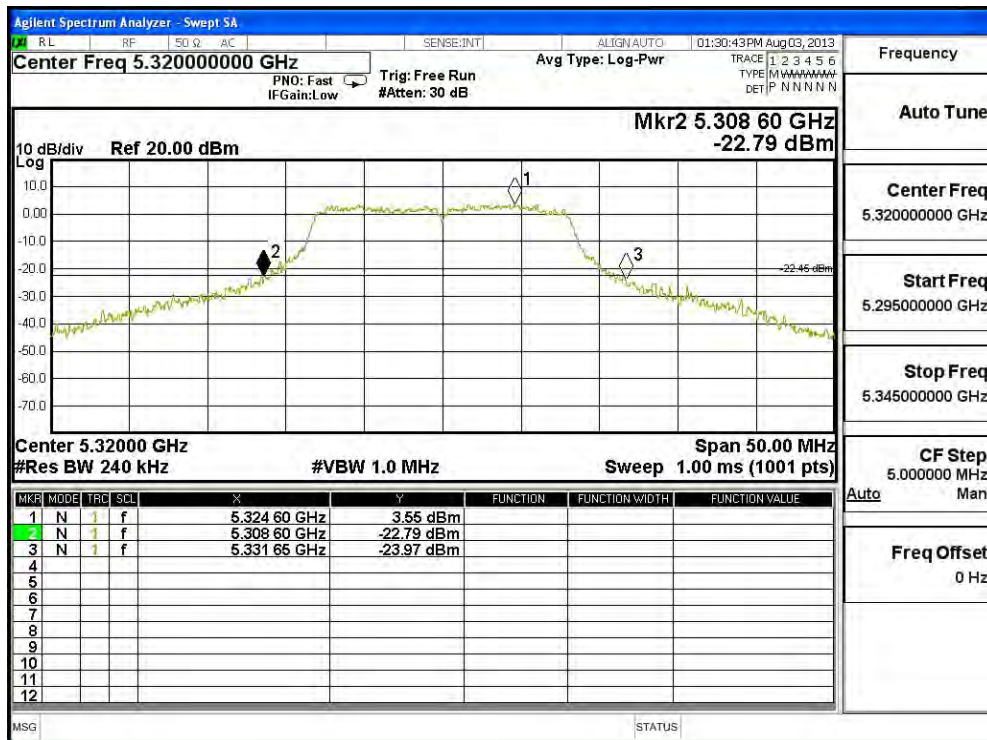

**Channel 100: CHAIN A**

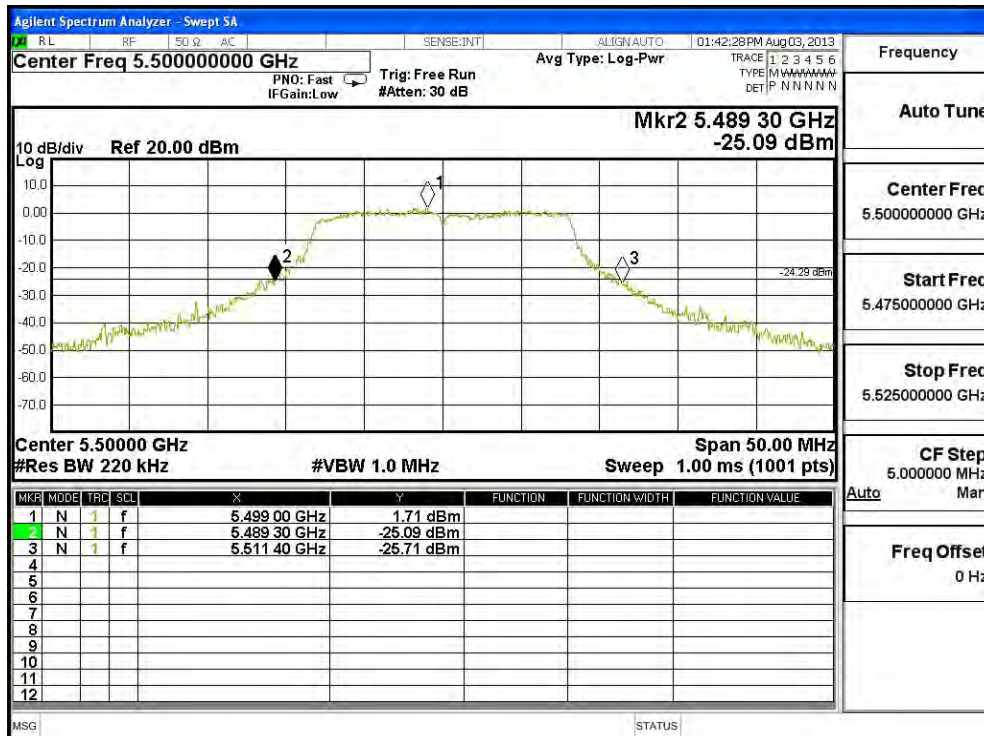



**Channel 116: CHAIN A**

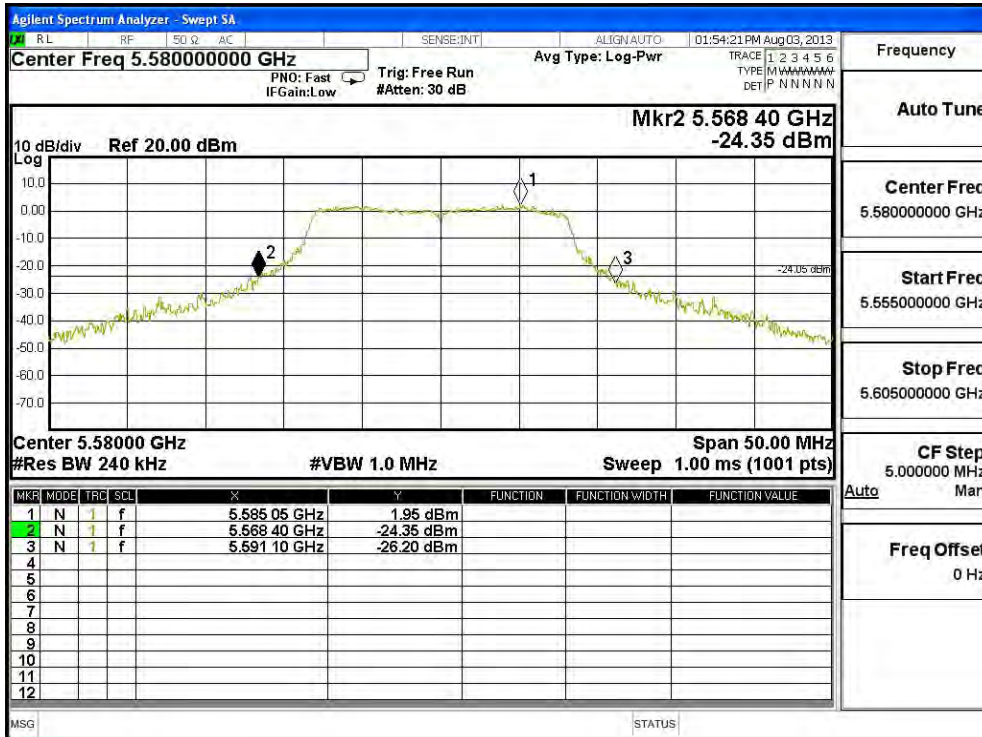

**Channel 140: CHAIN A**

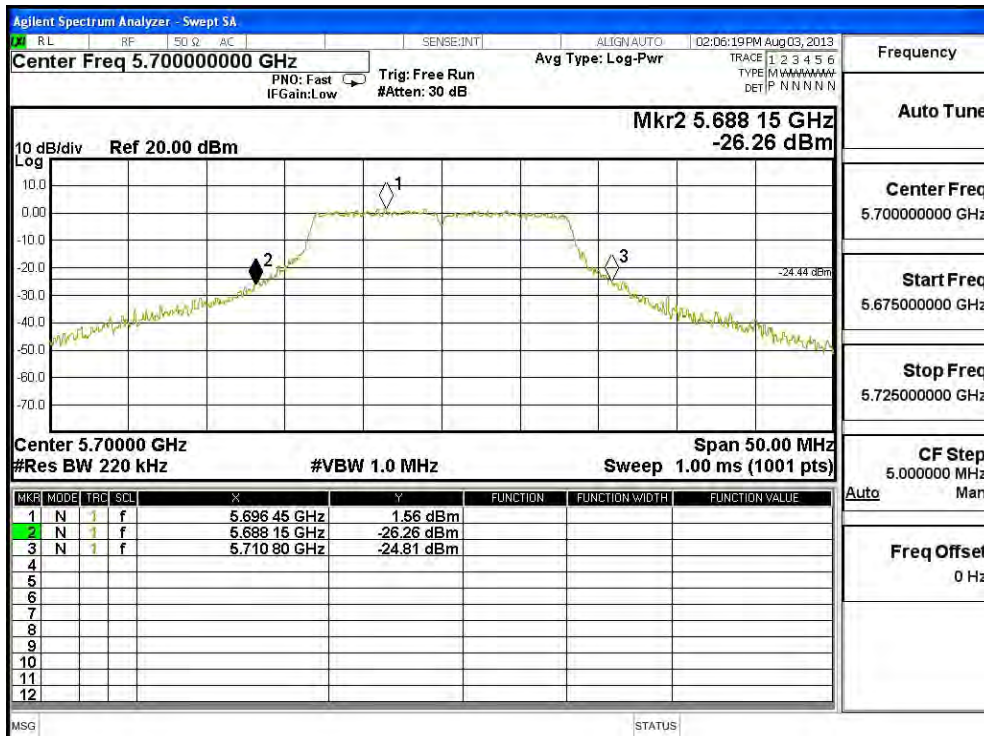

**26dBc Occupied Bandwidth:  
Channel 52: CHAIN B**

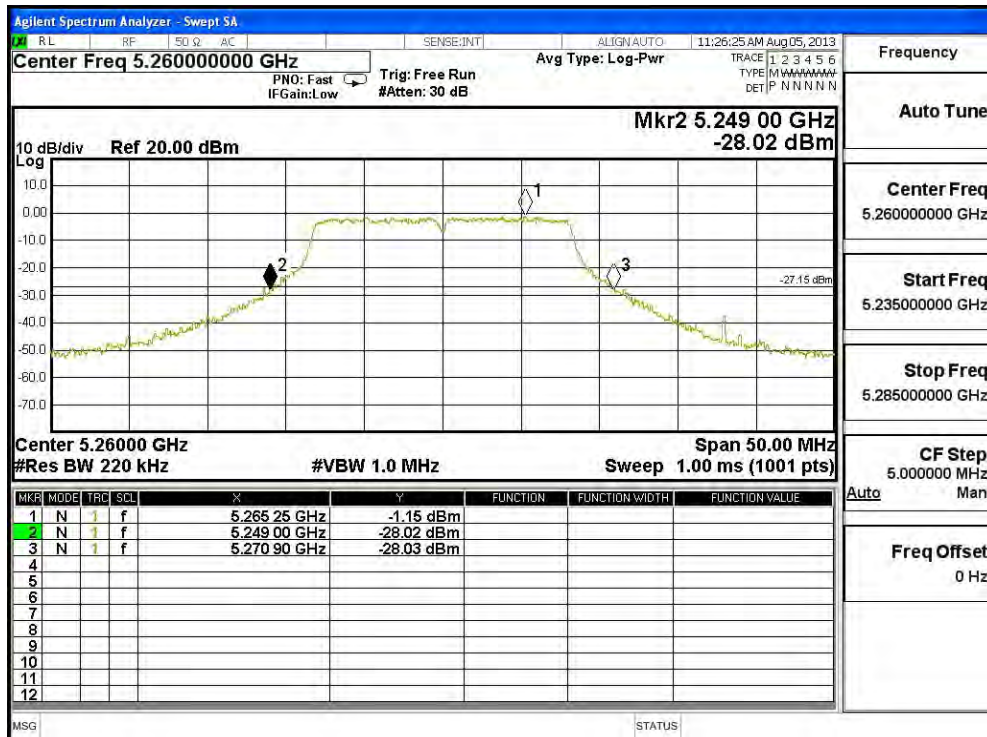

**Channel 60: CHAIN B**

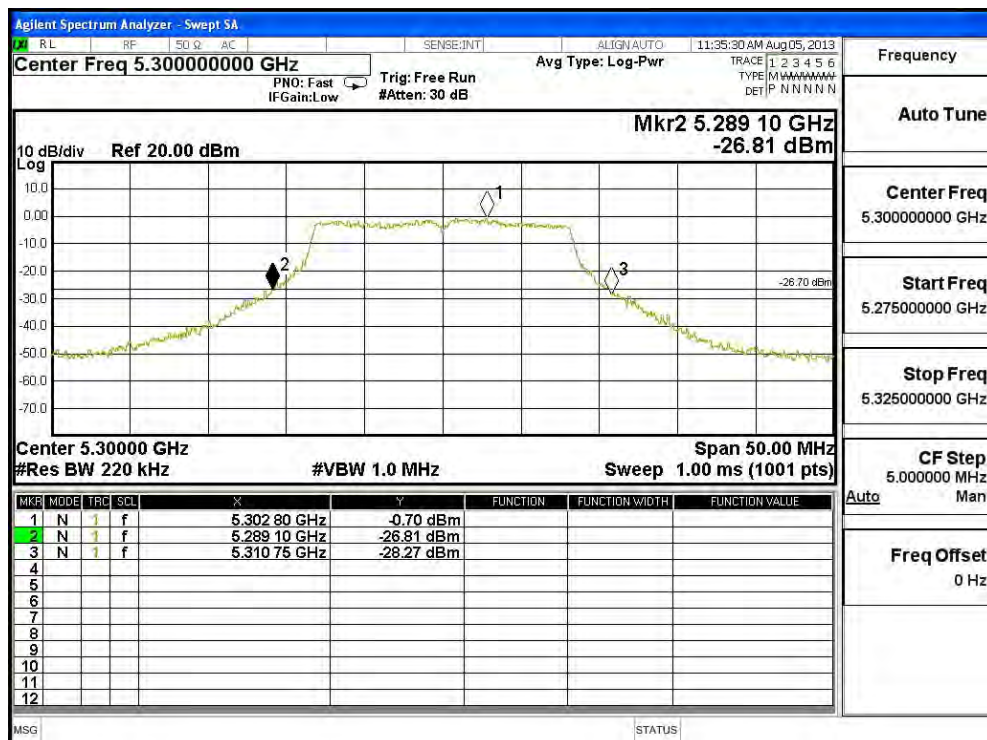

**Channel 64: CHAIN B**

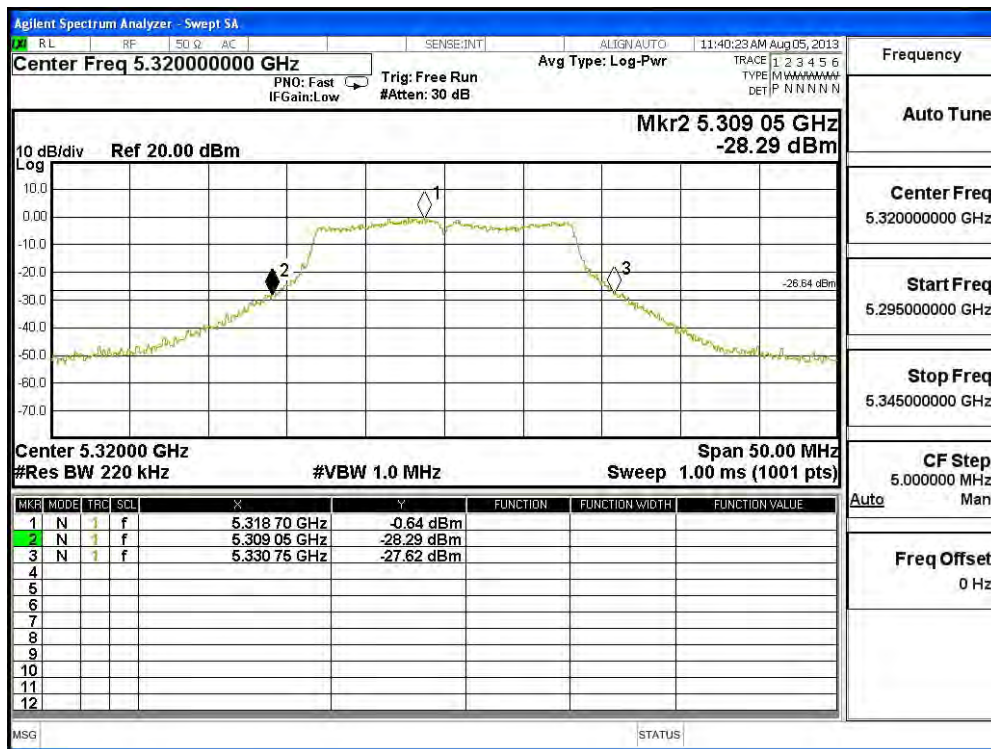

**Channel 100: CHAIN B**

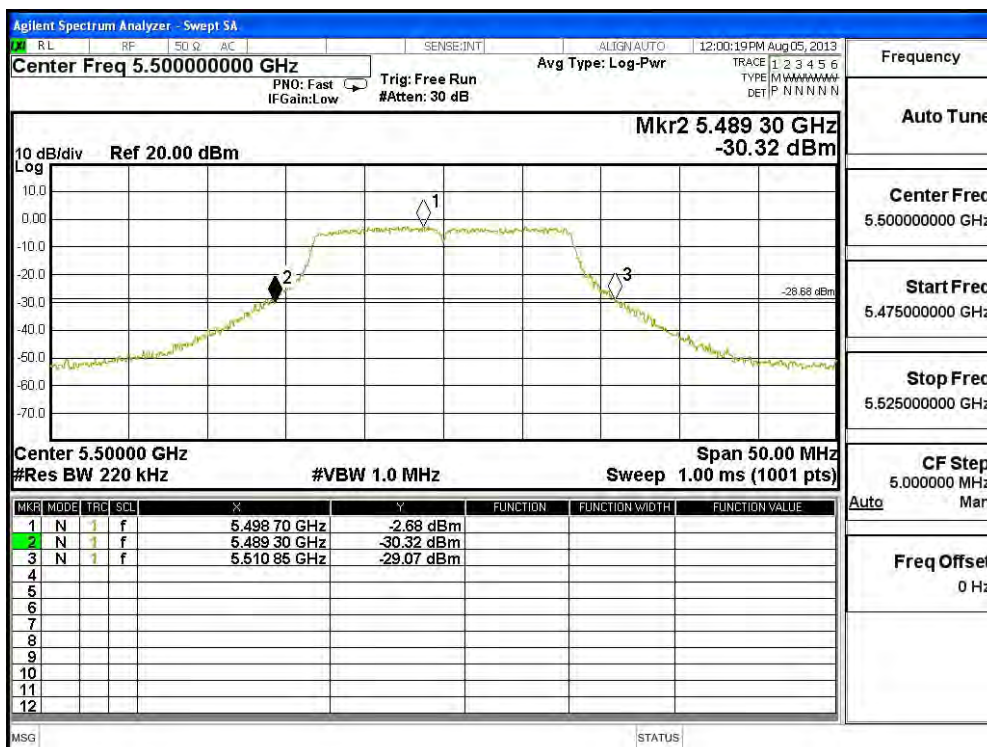

**Channel 116: CHAIN B**

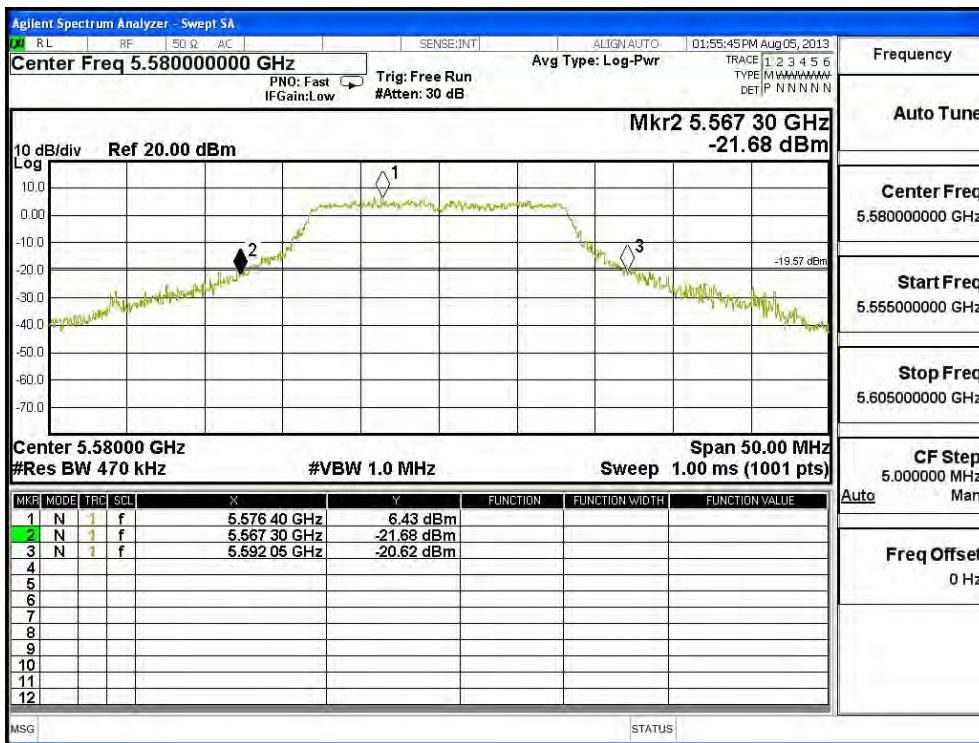

**Channel 140: CHAIN B**

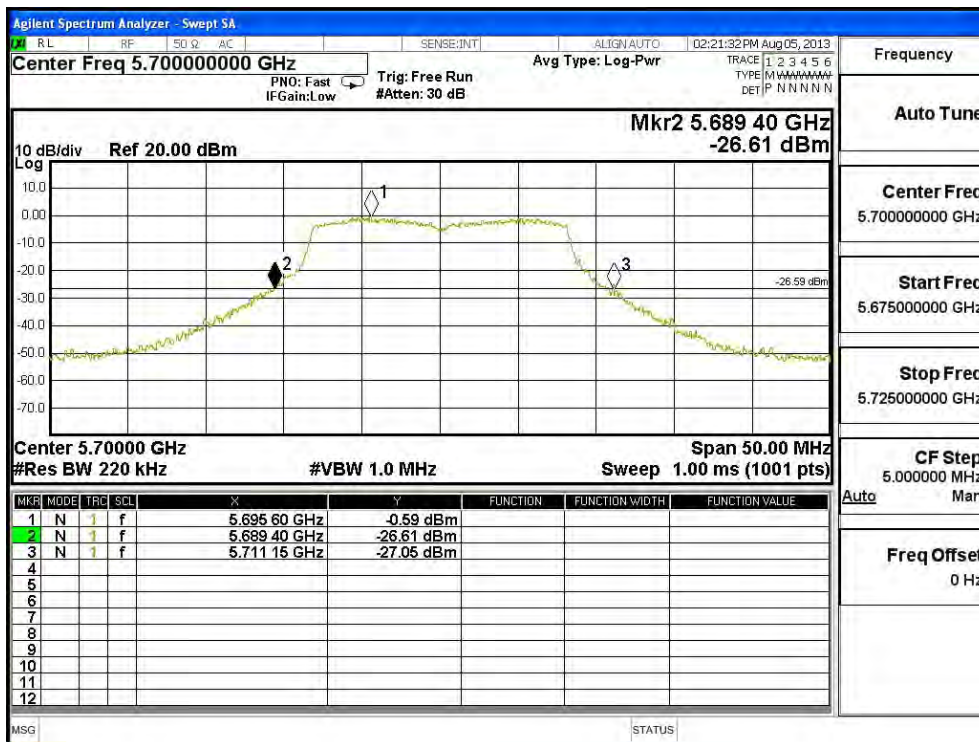

**26dBc Occupied Bandwidth:  
Channel 52: CHAIN C**

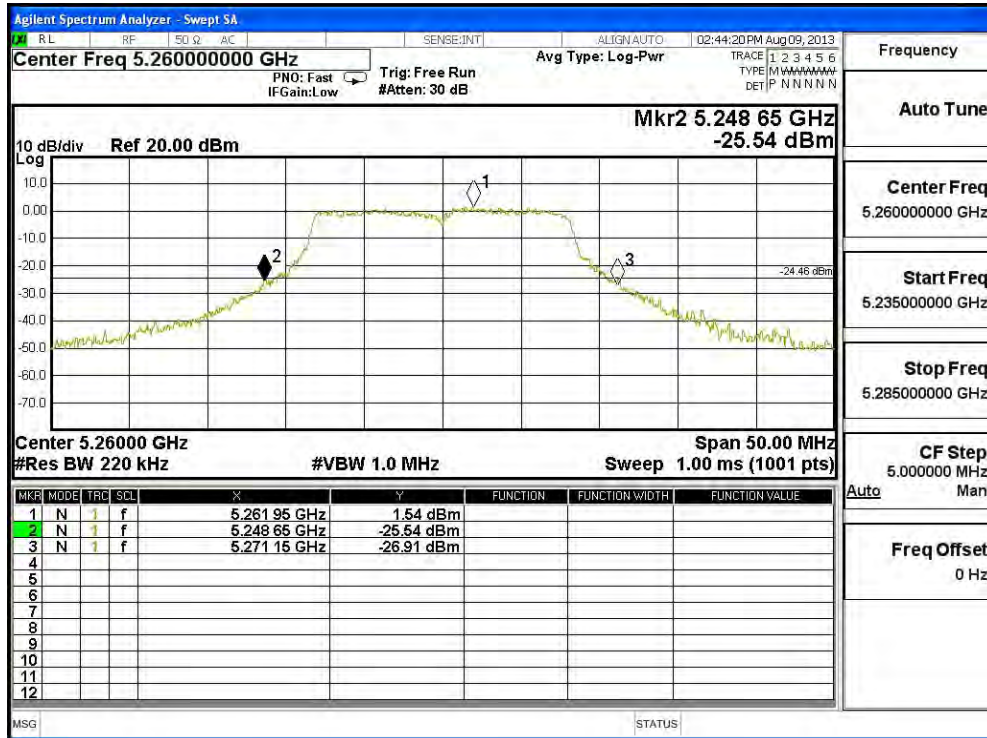

**Channel 60: CHAIN C**



**Channel 64: CHAIN C**

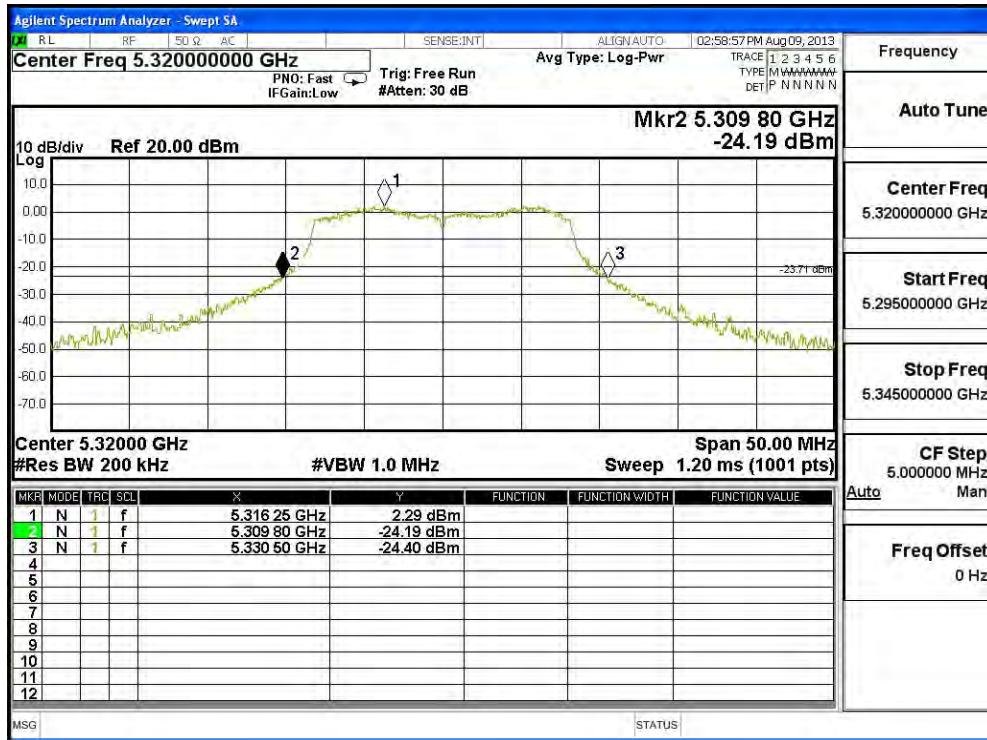

**Channel 100: CHAIN C**

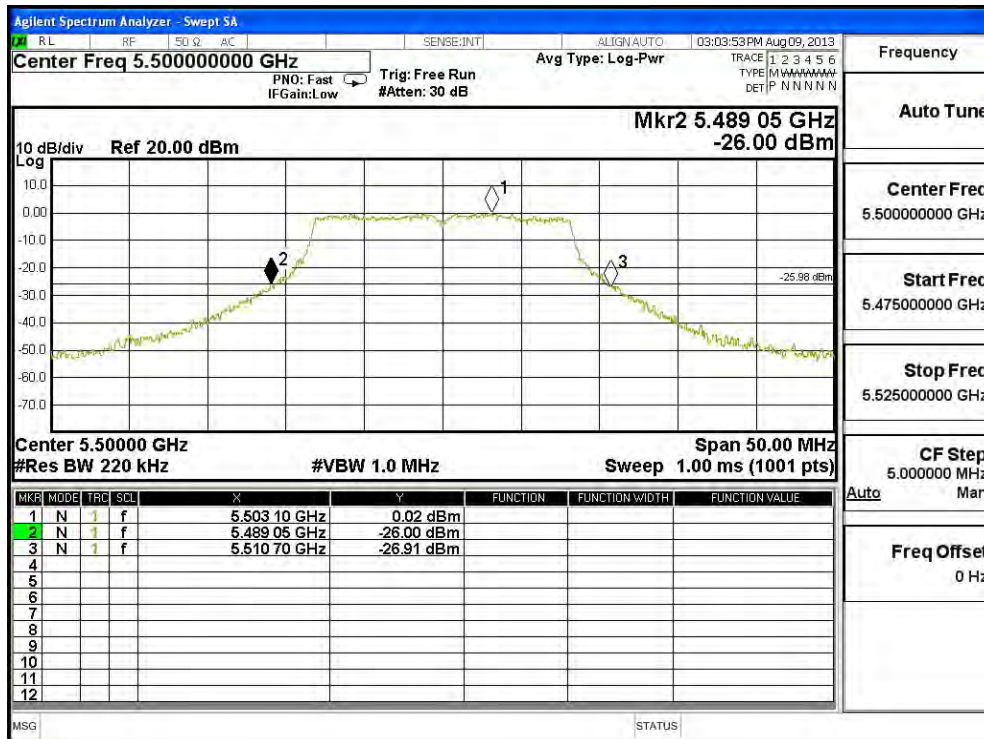

**Channel 116: CHAIN C**

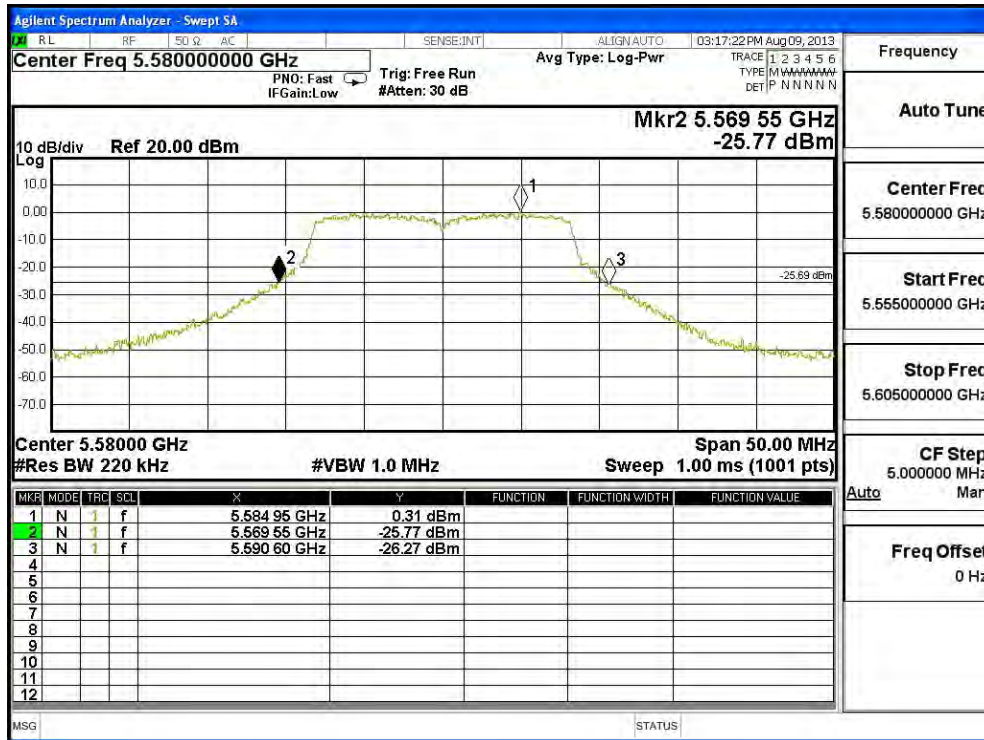

**Channel 140: CHAIN C**

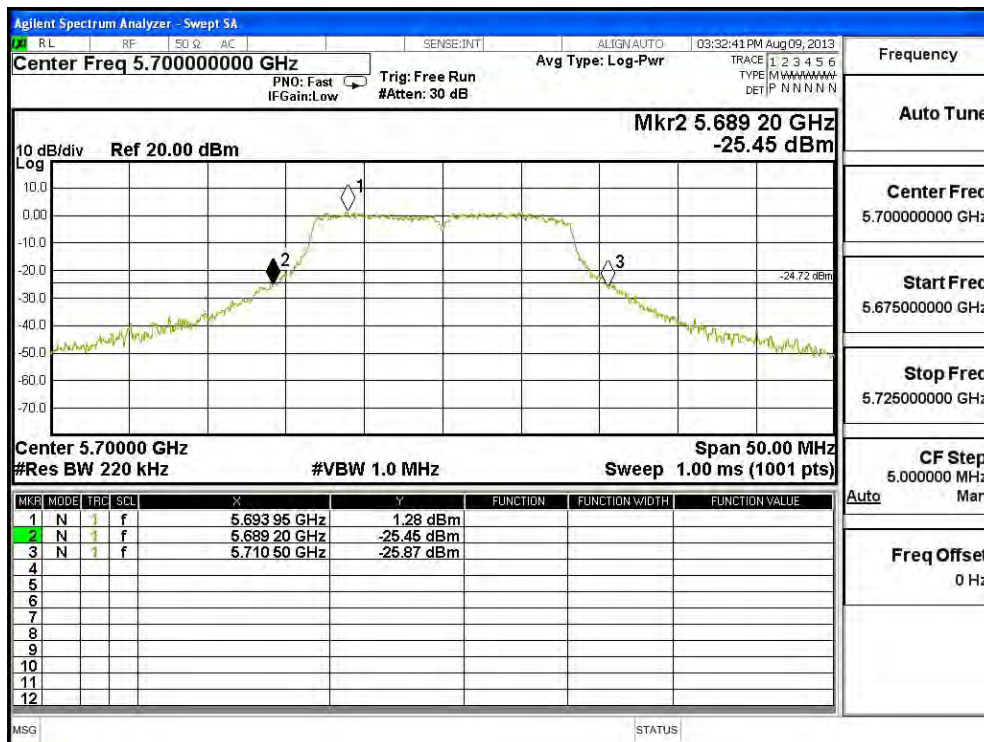

Product : SpectraGuard® Access Point / Sensor  
 Test Item : Maximum conducted output power  
 Test Site : No.3 OATS  
 Test Mode : Mode 2: Transmit (802.11n-20BW 21.7Mbps)(Dipole Antenna)

**CHAIN A**

Cable loss=1dB		Maximum conducted output power								
Channel No.	Frequency (MHz)	Data Rate (Mbps)								Required Limit
		21.7	43.3	65	86.7	130	173.3	195	216.7	
		Measurement Level (dBm)								
52	5260	14.66	--	--	--	--	--	--	--	<24dBm
60	5300	15.72	15.61	15.47	15.3	15.18	15.04	14.89	14.76	<24dBm
64	5320	15.61	--	--	--	--	--	--	--	<24dBm
100	5500	13.92	--	--	--	--	--	--	--	<24dBm
116	5580	15.3	15.11	14.99	14.82	14.67	14.51	14.36	14.2	<24dBm
140	5700	14.77	--	--	--	--	--	--	--	<24dBm

Note: 1.Maximum conducted output power Value =Reading value on average power meter + cable loss

**CHAIN B**

Cable loss=1dB		Maximum conducted output power								
Channel No.	Frequency (MHz)	Data Rate (Mbps)								Required Limit
		21.7	43.3	65	86.7	130	173.3	195	216.7	
		Measurement Level (dBm)								
52	5260	15.43	--	--	--	--	--	--	--	<24dBm
60	5300	12.67	12.5	12.38	12.23	12.08	11.94	11.79	11.65	<24dBm
64	5320	12.42	--	--	--	--	--	--	--	<24dBm
100	5500	12.56	--	--	--	--	--	--	--	<24dBm
116	5580	11.82	11.71	11.55	11.42	11.29	11.15	11.02	10.88	<24dBm
140	5700	12.73	--	--	--	--	--	--	--	<24dBm

Note: 1.Maximum conducted output power Value =Reading value on average power meter + cable loss



**CHAIN C**

Cable loss=1dB		Maximum conducted output power								
Channel No.	Frequency (MHz)	Data Rate (Mbps)								Required Limit
		21.7	43.3	65	86.7	130	173.3	195	216.7	
		Measurement Level (dBm)								
52	5260	12.79	--	--	--	--	--	--	--	<24dBm
60	5300	14.47	14.31	14.19	14.04	13.9	13.76	13.62	13.48	<24dBm
64	5320	14.5	--	--	--	--	--	--	--	<24dBm
100	5500	14.47	--	--	--	--	--	--	--	<24dBm
116	5580	13.88	13.74	13.56	13.41	13.25	13.09	12.93	12.77	<24dBm
140	5700	14.41	--	--	--	--	--	--	--	<24dBm

Note: 1. Maximum conducted output power Value = Reading value on average power meter + cable loss

**Maximum conducted output power Measurement:**
**(CHAIN A+ B+C)**

Channel Number	Frequency (MHz)	26dB Bandwidth (MHz)	Chain A Power (dBm)	Chain B Power (dBm)	Chain C Power (dBm)	Output Power (dBm)	Output Power Limit	
							(dBm)	dBm+10log(BW)
52	5260	21.950	14.66	15.43	12.79	19.20	24	24.41
60	5300	22.200	15.72	12.67	14.47	19.23	24	24.46
64	5320	22.350	15.61	12.42	14.50	19.14	24	24.49
100	5500	22.300	13.92	12.56	14.47	18.49	24	24.48
116	5580	22.350	15.30	11.82	13.88	18.66	24	24.49
140	5700	22.250	14.77	12.73	14.41	18.83	24	24.47

Note:

1. Power Output Value = Reading value on average power meter + cable loss
2. Output Power (dBm) = 10LOG (Chain A Power (mW)+ Chain B Power (mW) + Chain C Power (mW))
3. 26 dB Bandwidth is the bandwidth of chain A or chain B or chain C whichever is less bandwidth, output power limitation is more stringent.

**26dBc Occupied Bandwidth:  
Channel 52 -Chain A**

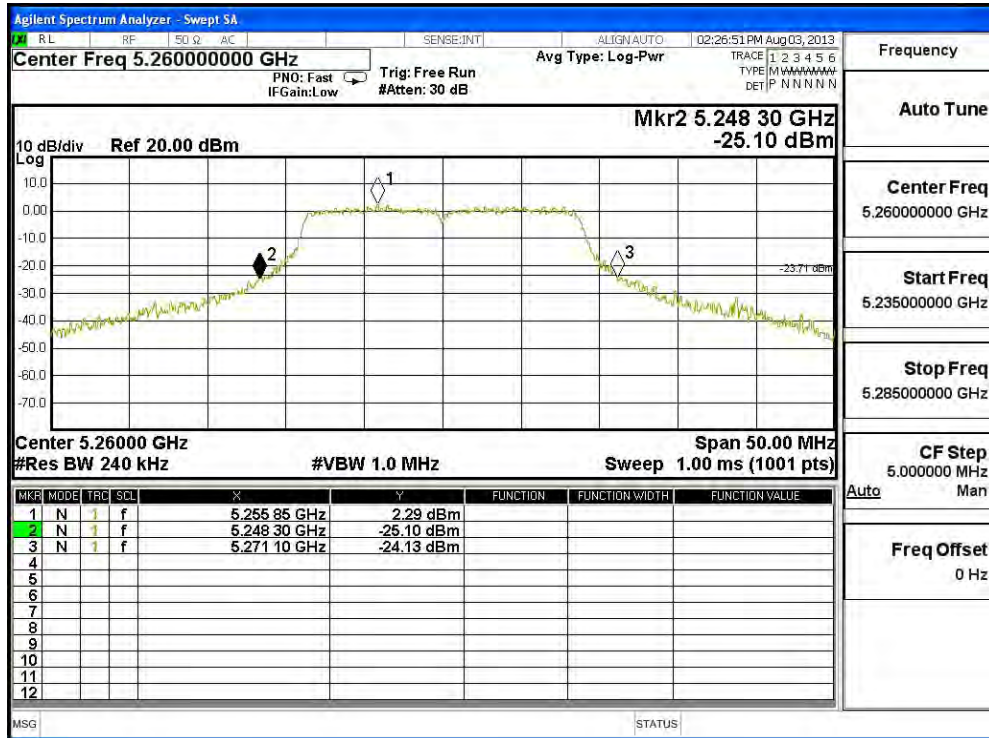

**Channel 60 -Chain A**

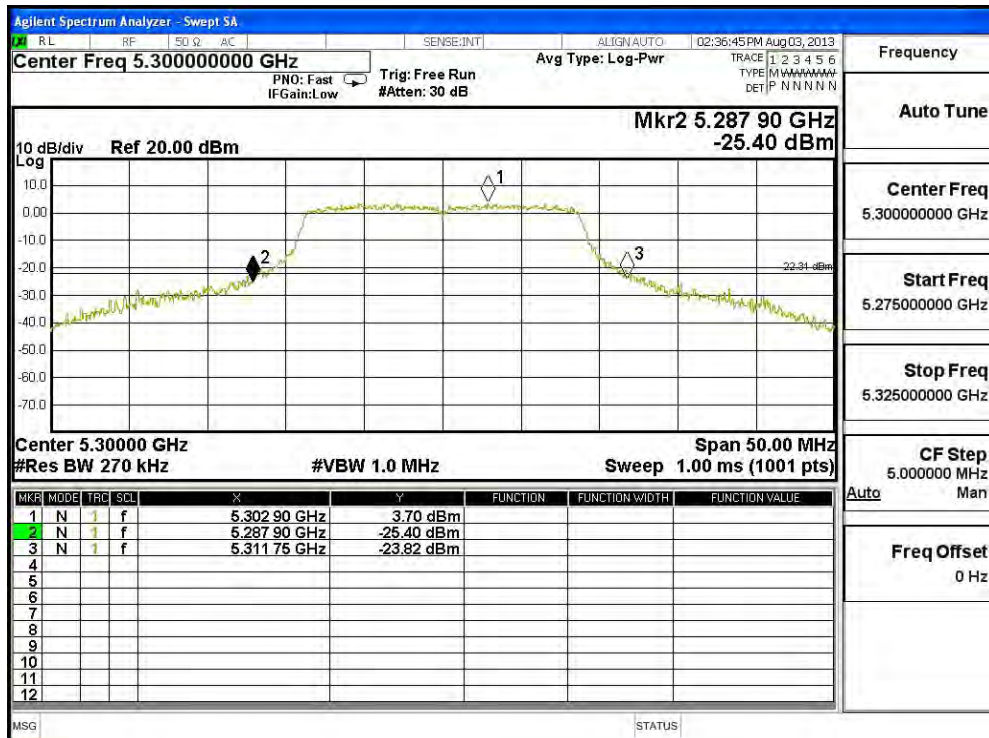

**Channel 64 -Chain A**

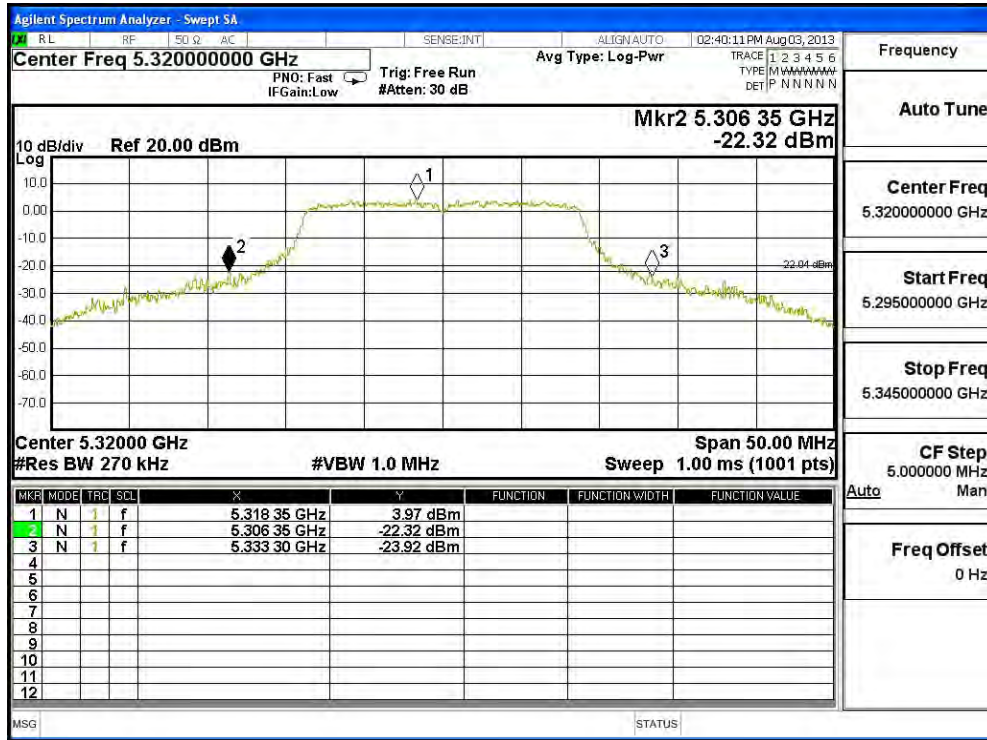

**Channel 100 -Chain A**

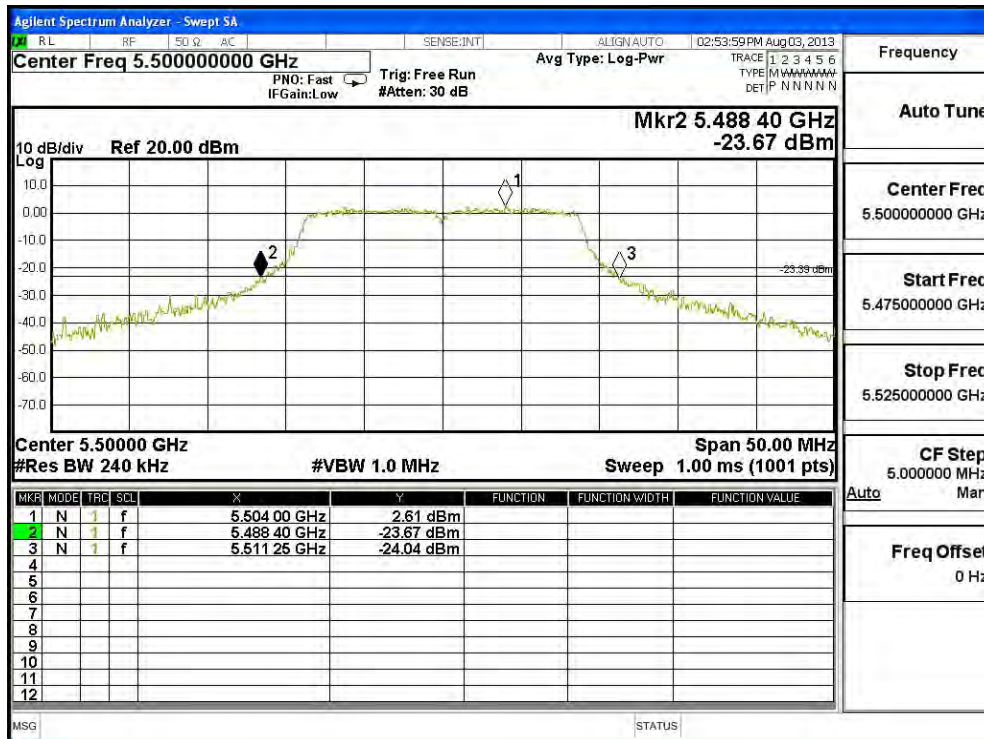

### Channel 116 -Chain A

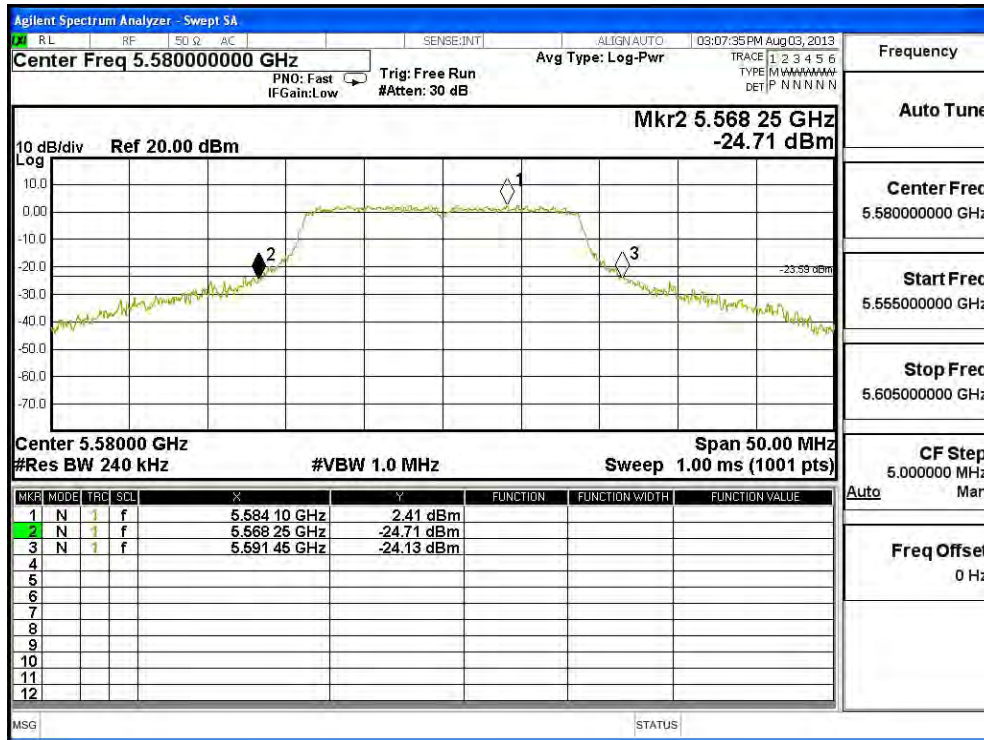

### Channel 140 -Chain A

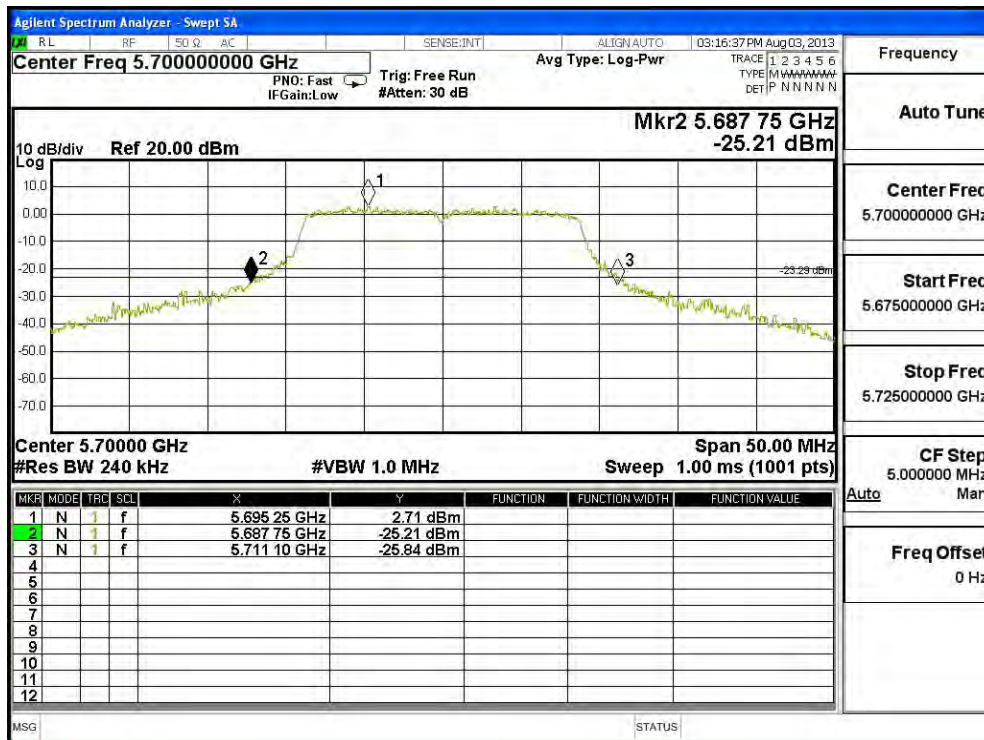

**26dBc Occupied Bandwidth:  
Channel 52 -Chain B**

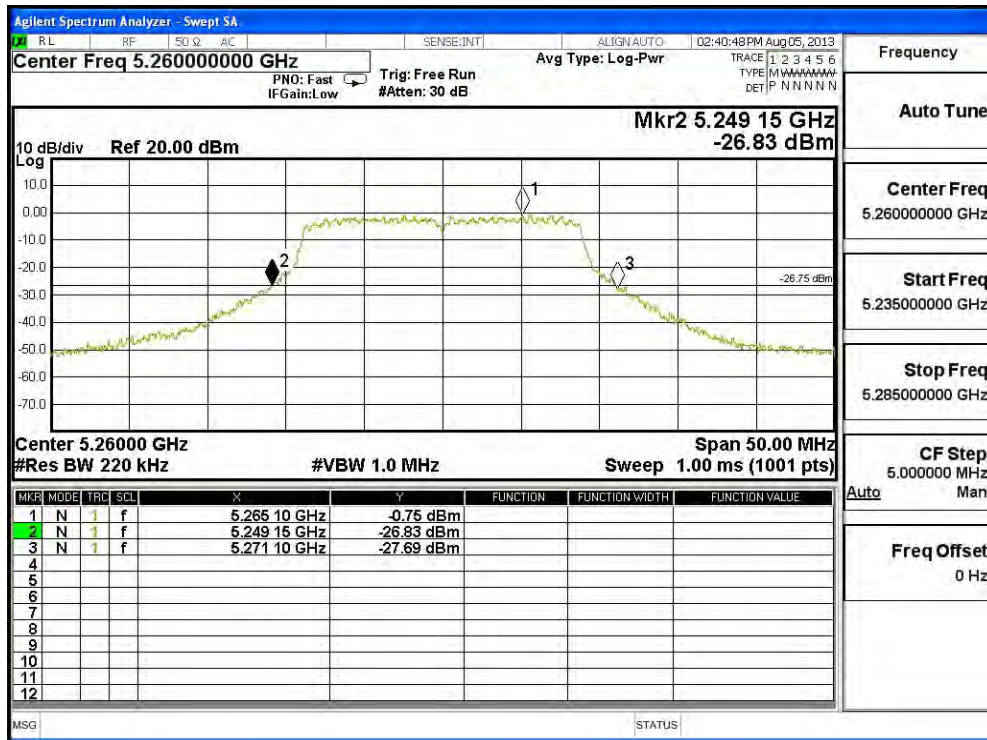

**Channel 60 -Chain B**

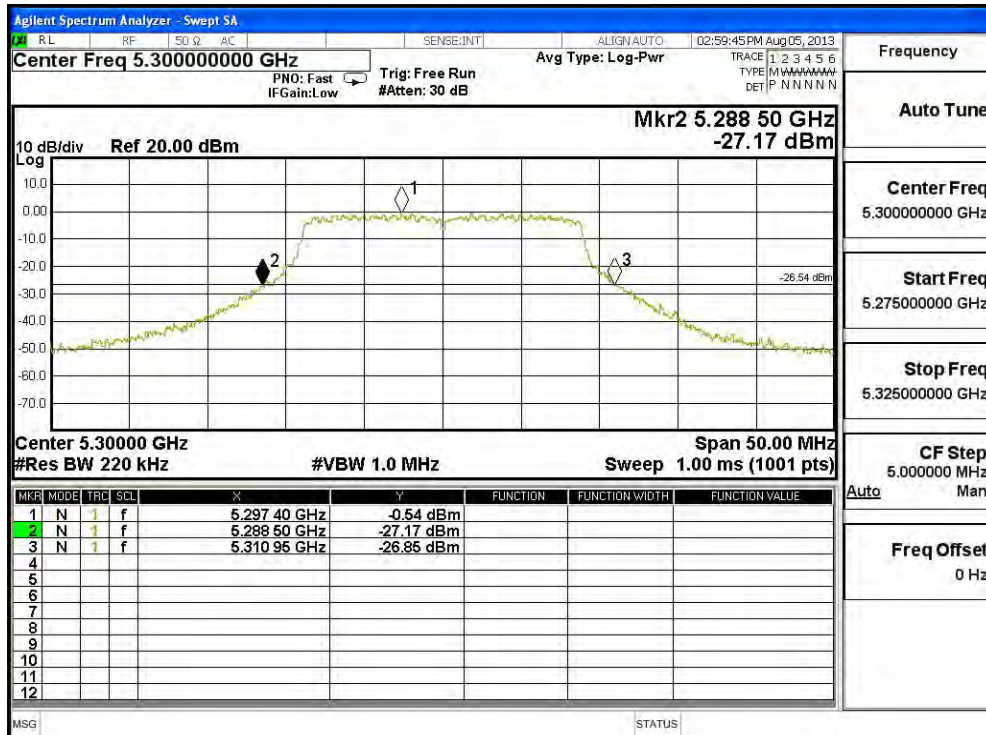

Channel 64 -Chain B

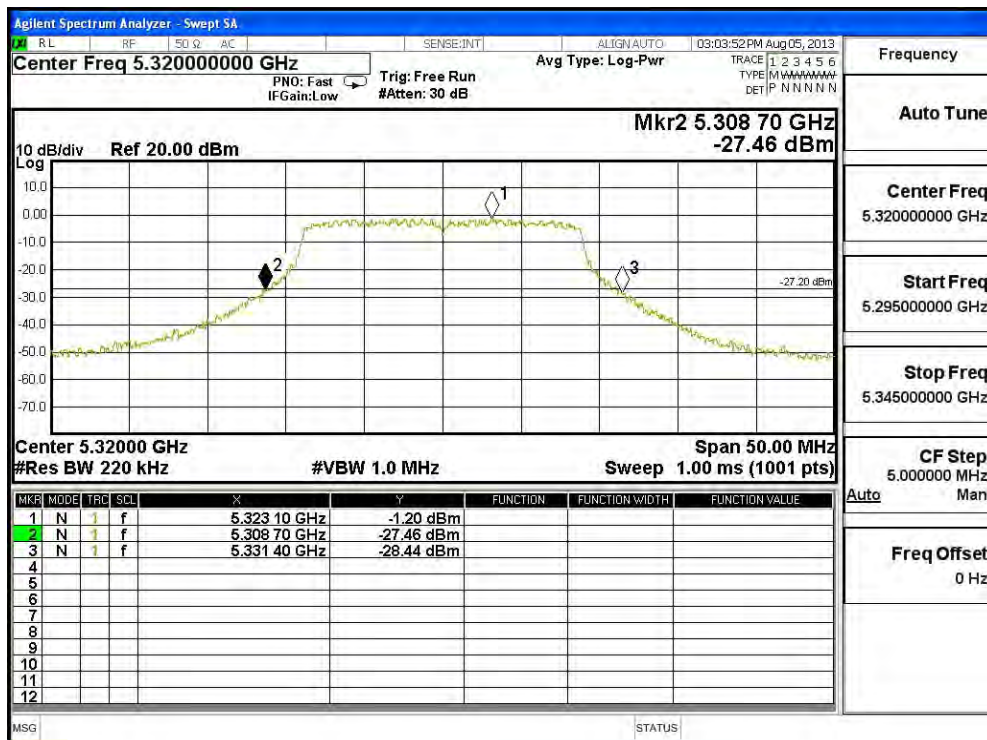

Channel 100 -Chain B

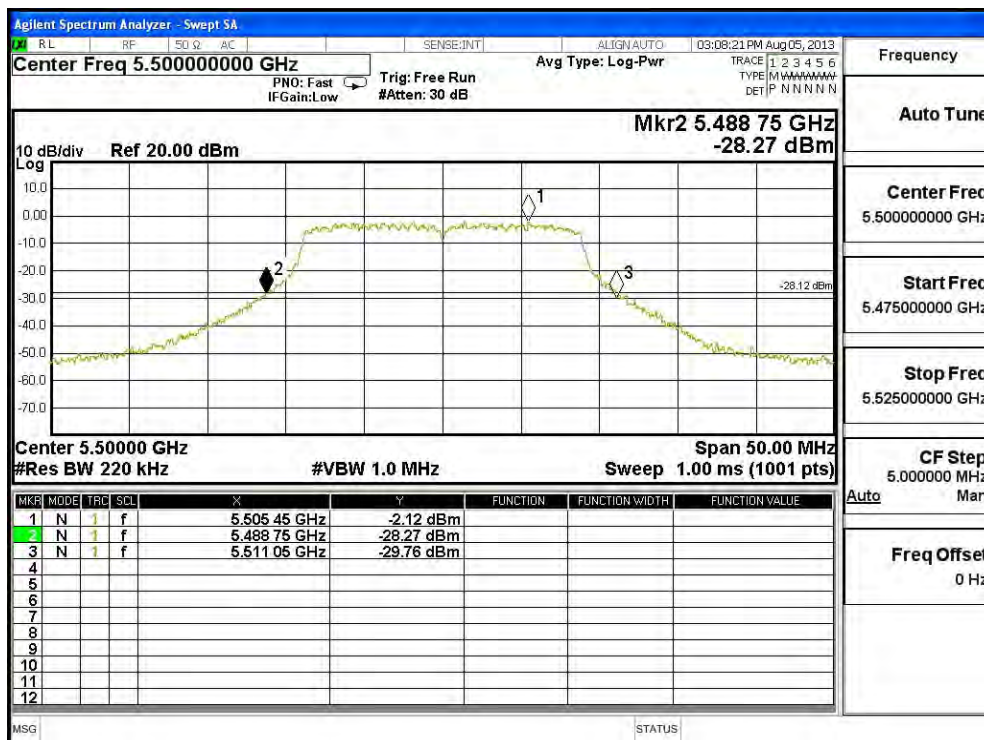

**Channel 116 -Chain B**

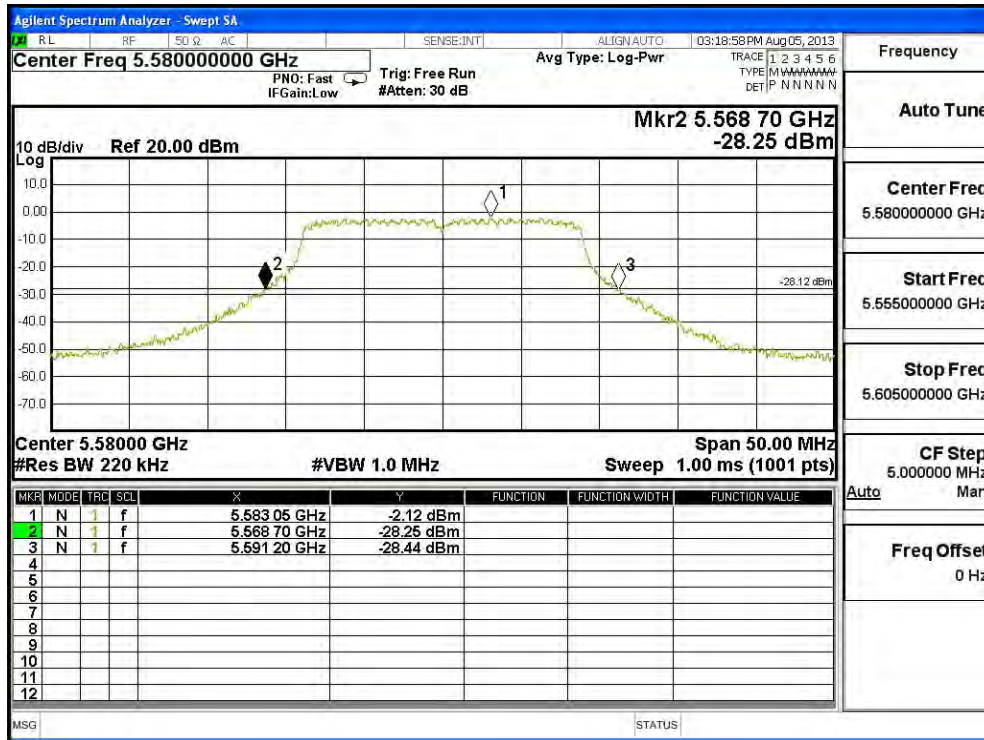

**Channel 140 -Chain B**

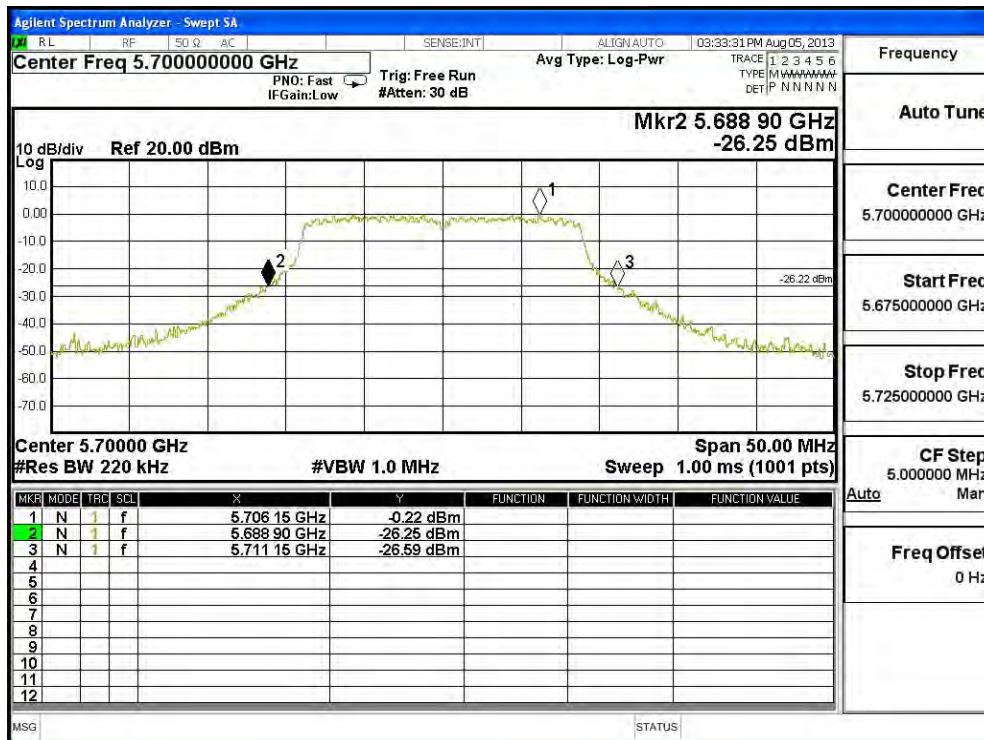

**26dBc Occupied Bandwidth:  
Channel 52 -Chain C**

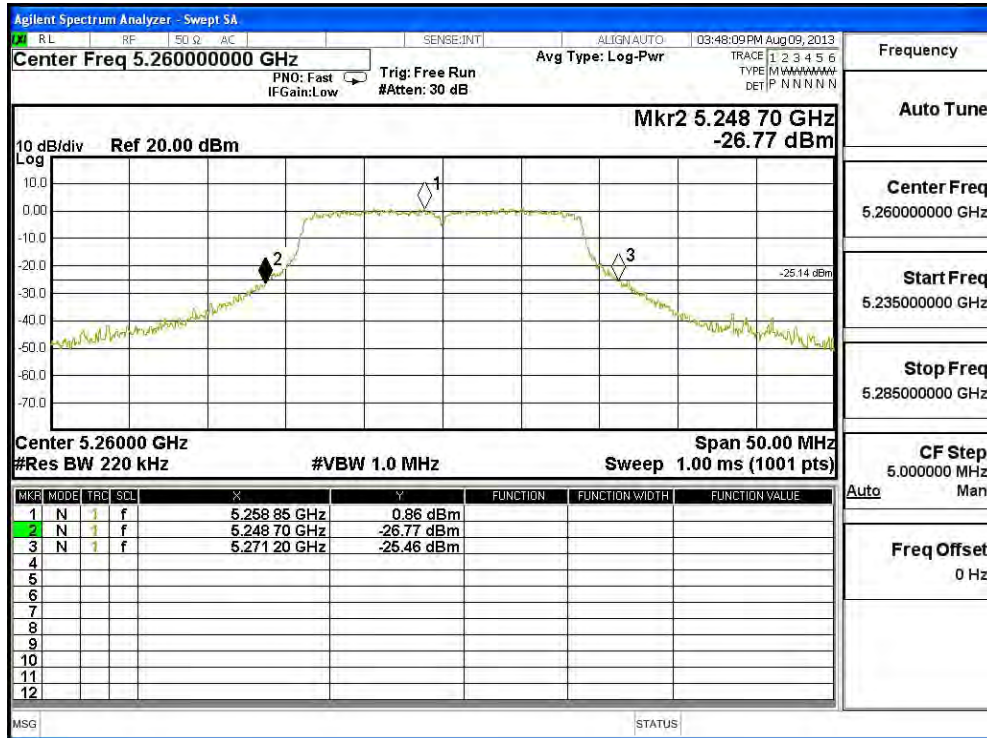

**Channel 60 -Chain C**

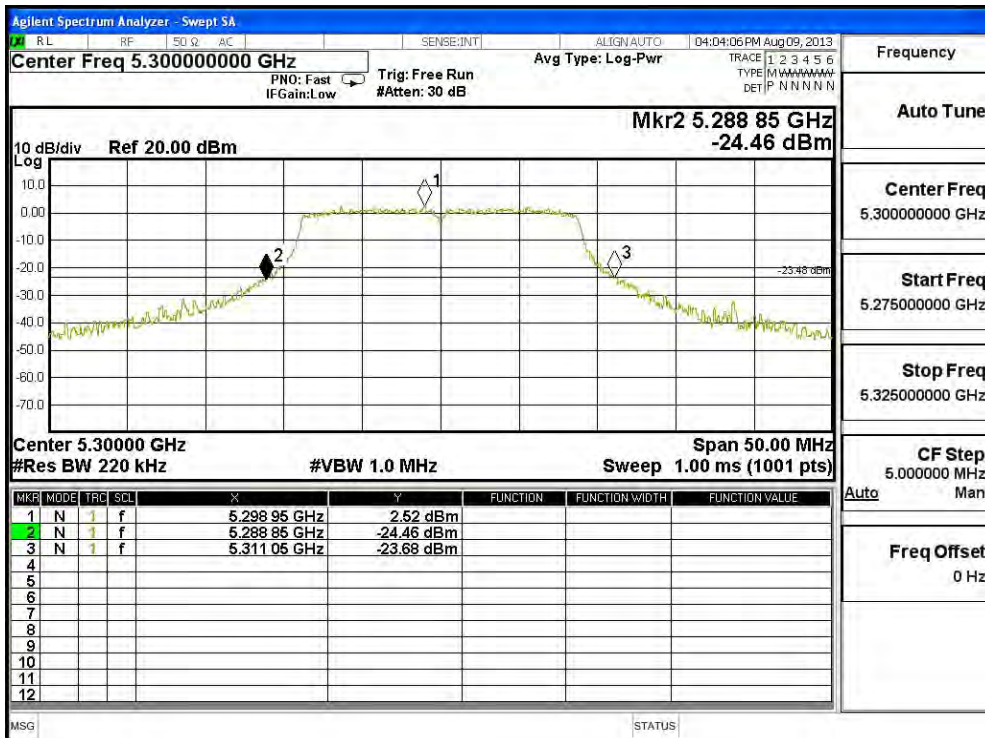



**Channel 64 -Chain C**

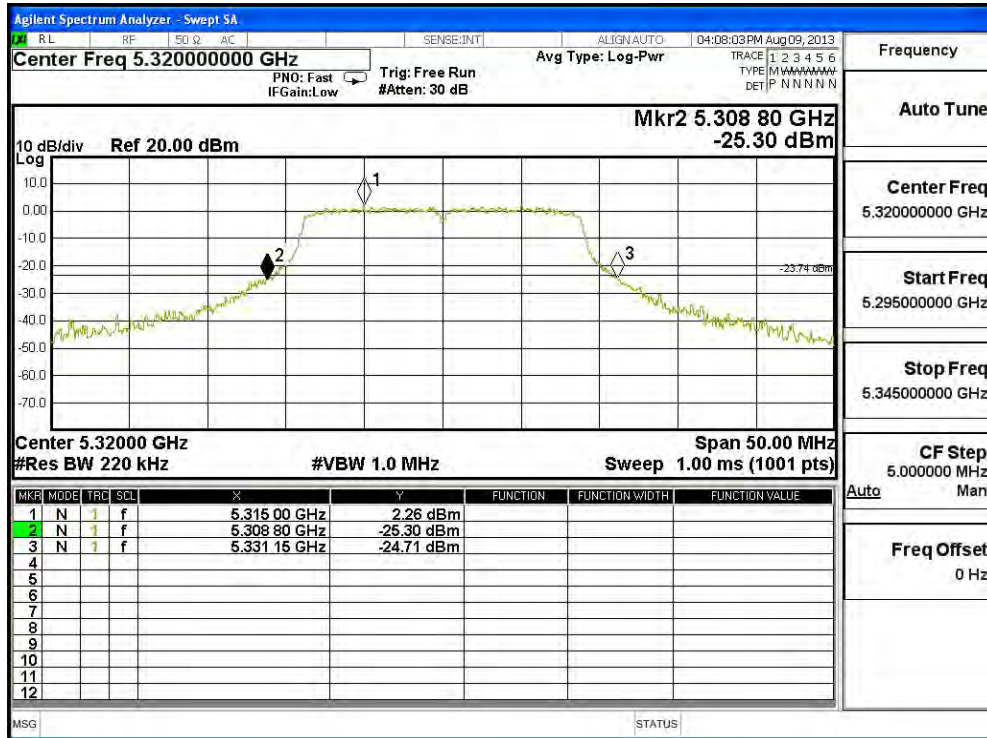

**Channel 100 -Chain C**

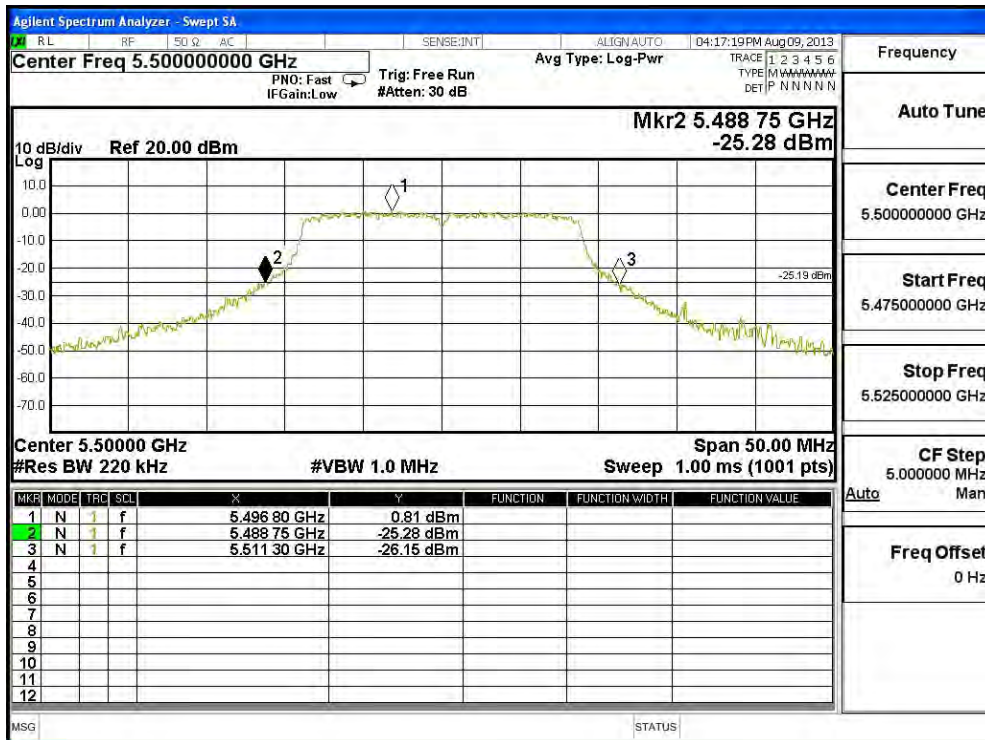

### Channel 116 -Chain C

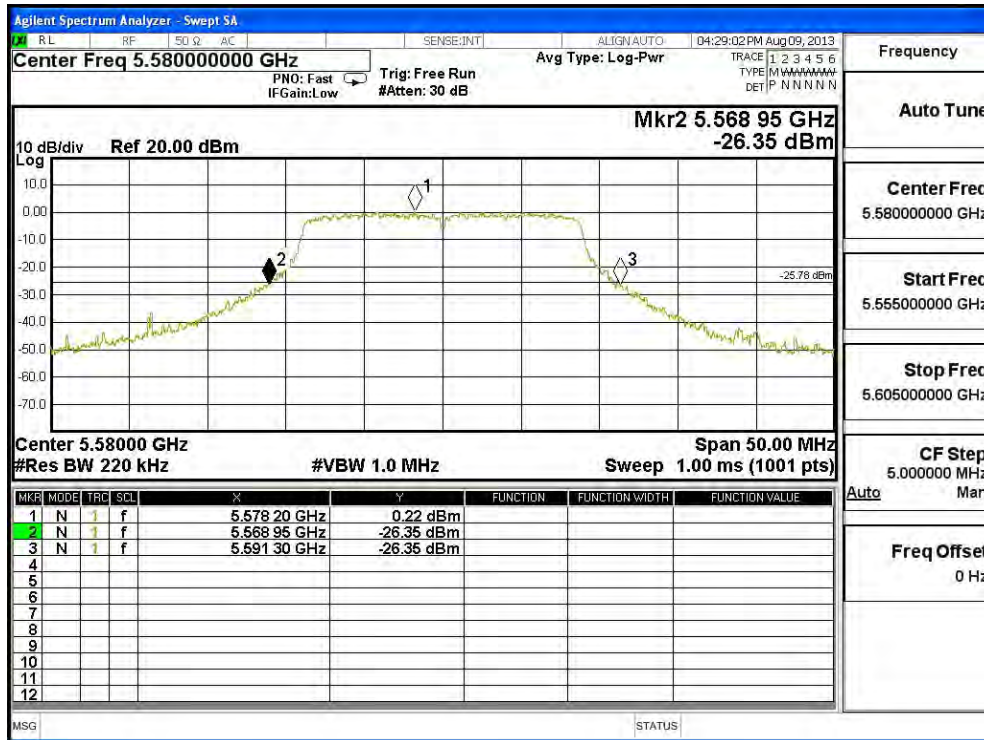

### Channel 140 -Chain C

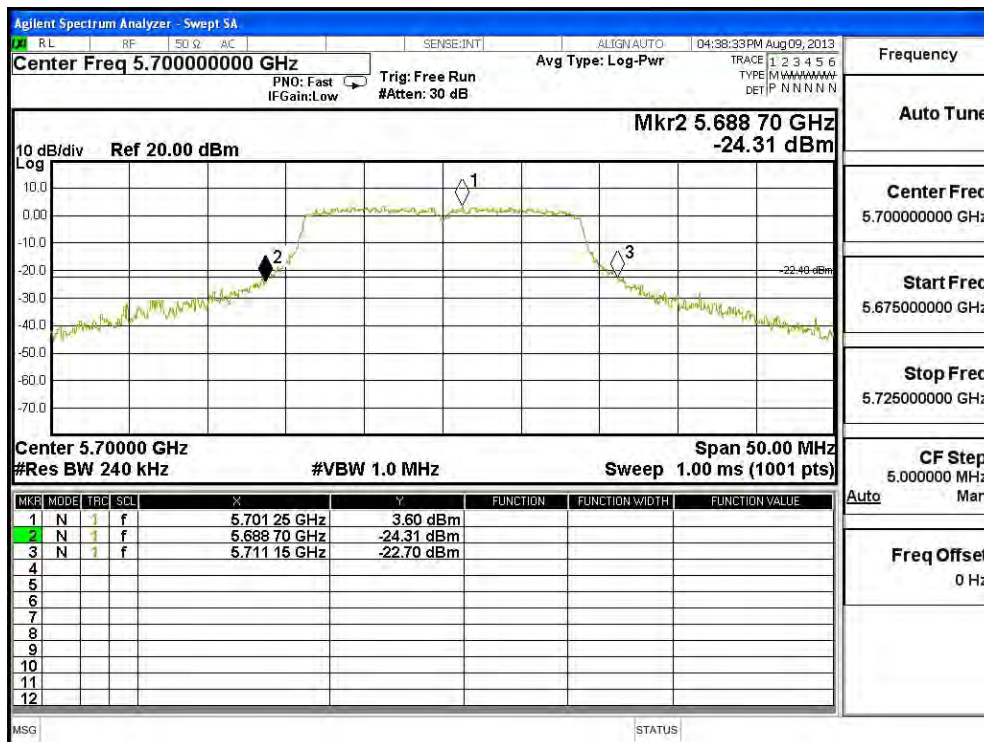

Product : SpectraGuard® Access Point / Sensor  
 Test Item : Maximum conducted output power  
 Test Site : No.3 OATS  
 Test Mode : Mode 3: Transmit (802.11n-40BW 45Mbps)(Dipole Antenna)

**CHAIN A**

Cable loss=1dB		Maximum conducted output power								
Channel No.	Frequency (MHz)	Data Rate (Mbps)								Required Limit
		45	90	135	180	270	360	405	450	
		Measurement Level (dBm)								
54	5270	14.68	--	--	--	--	--	--	--	<24dBm
62	5310	11.34	11.28	11.11	11.01	10.89	10.78	10.67	10.55	<24dBm
102	5510	13.04	--	--	--	--	--	--	--	<24dBm
110	5550	16.57	16.4	16.27	16.11	15.96	15.81	15.66	15.51	<24dBm
134	5670	14.8	--	--	--	--	--	--	--	<24dBm

Note: 1.Maximum conducted output power Value =Reading value on average power meter + cable loss

**CHAIN B**

Cable loss=1dB		Maximum conducted output power								
Channel No.	Frequency (MHz)	Data Rate (Mbps)								Required Limit
		45	90	135	180	270	360	405	450	
		Measurement Level (dBm)								
54	5270	13.52	--	--	--	--	--	--	--	<24dBm
62	5310	8.34	8.19	8.05	7.90	7.76	7.61	7.47	7.32	<24dBm
102	5510	11.68	--	--	--	--	--	--	--	<24dBm
110	5550	13.62	13.41	13.27	13.08	12.91	12.73	12.56	12.38	<24dBm
134	5670	13.39	--	--	--	--	--	--	--	<24dBm

Note: 1.Maximum conducted output power Value =Reading value on average power meter + cable loss

**CHAIN C**

Cable loss=1dB		Maximum conducted output power								
Channel No.	Frequency (MHz)	Data Rate (Mbps)								Required Limit
		45	90	135	180	270	360	405	450	
		Measurement Level (dBm)								
54	5270	15.34	--	--	--	--	--	--	--	<24dBm
62	5310	10.67	10.45	10.29	10.09	9.9	9.71	9.52	9.33	<24dBm
102	5510	13.72	--	--	--	--	--	--	--	<24dBm
110	5550	14.82	14.74	14.6	14.5	14.39	14.28	14.17	14.06	<24dBm
134	5670	15.29	--	--	--	--	--	--	--	<24dBm

Note: 1. Maximum conducted output power Value = Reading value on average power meter + cable loss

**Maximum conducted output power Measurement:**
**(CHAIN A+ B+C)**

Channel Number	Frequency (MHz)	26dB Bandwidth (MHz)	Chain A Power (dBm)	Chain B Power (dBm)	Chain C Power (dBm)	Output Power (dBm)	Output Power Limit	
							(dBm)	dBm+10log(BW)
54	5270	43.600	14.68	13.52	15.34	19.35	24	27.39
62	5310	44.000	11.34	8.34	10.67	15.07	24	27.43
102	5510	43.900	13.04	11.68	13.72	17.66	24	27.42
110	5550	44.200	16.57	13.62	14.82	19.95	24	27.45
134	5670	43.700	14.80	13.39	15.29	19.34	24	27.40

Note:

1. Power Output Value = Reading value on average power meter + cable loss
2. Output Power (dBm) = 10LOG (Chain A Power (mW)+ Chain B Power (mW))
3. 26 dB Bandwidth is the bandwidth of chain A or chain B or chain C whichever is less bandwidth, output power limitation is more stringent.

**26dBc Occupied Bandwidth:  
Channel 54 – Chain A**

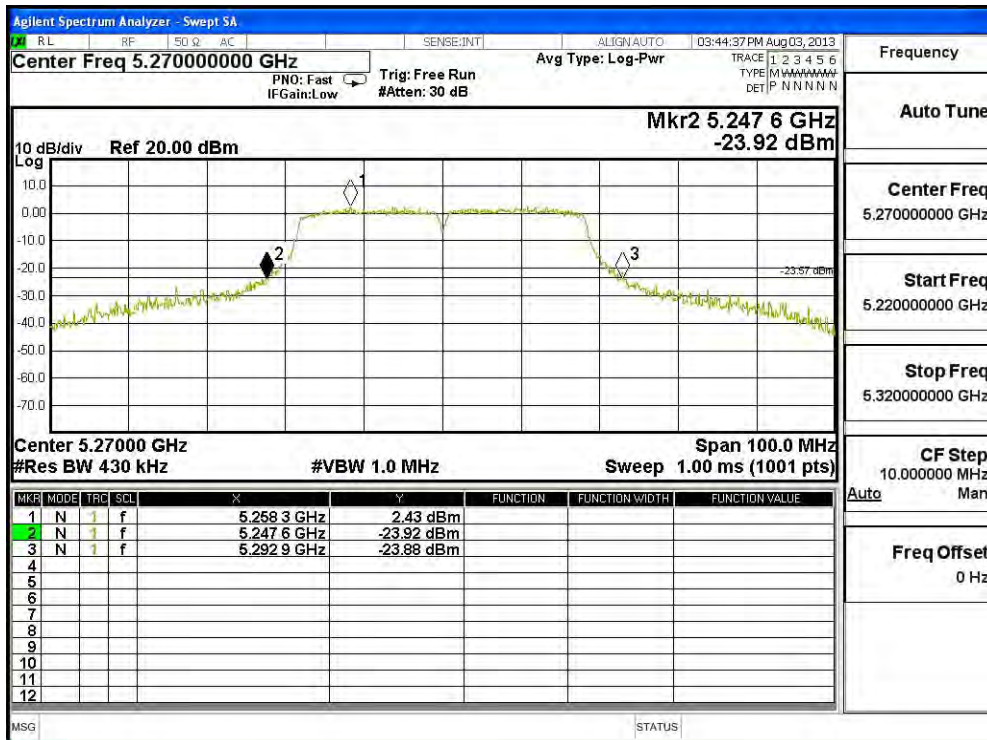

**Channel 62 – Chain A**

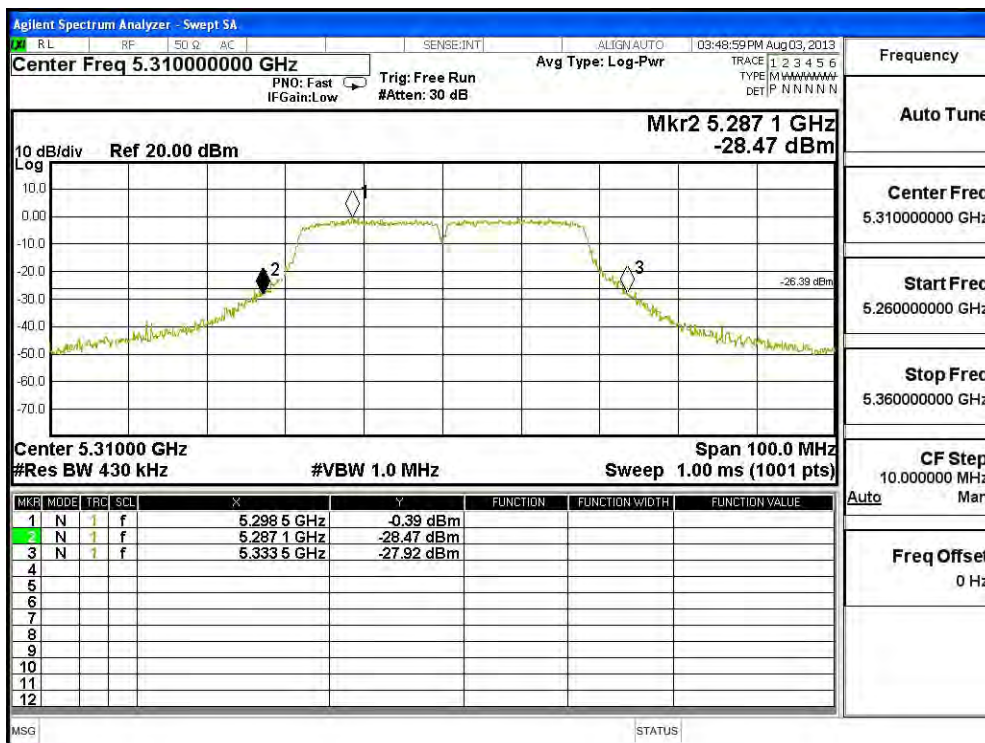

**Channel 102 – Chain A**

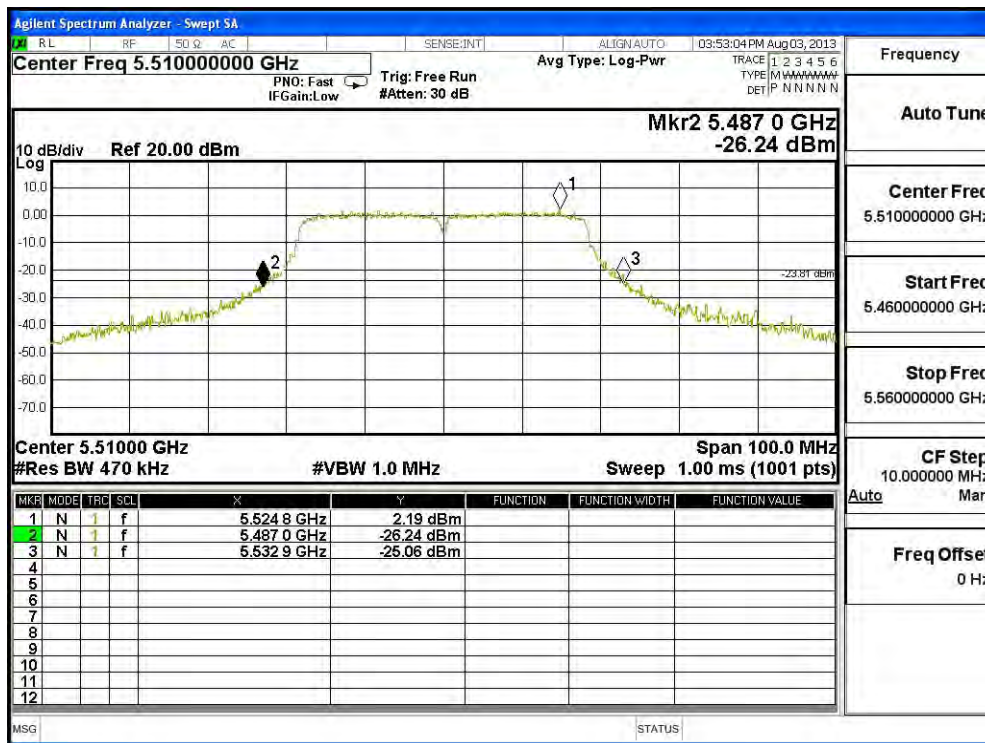

**Channel 110 – Chain A**

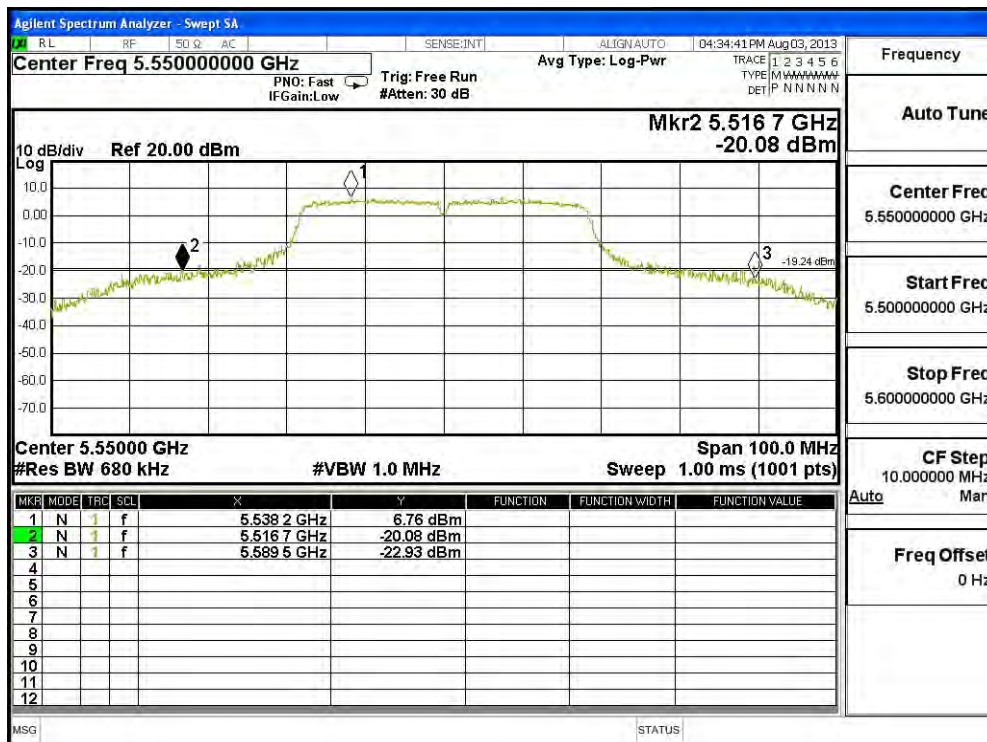

Channel 134 – Chain A

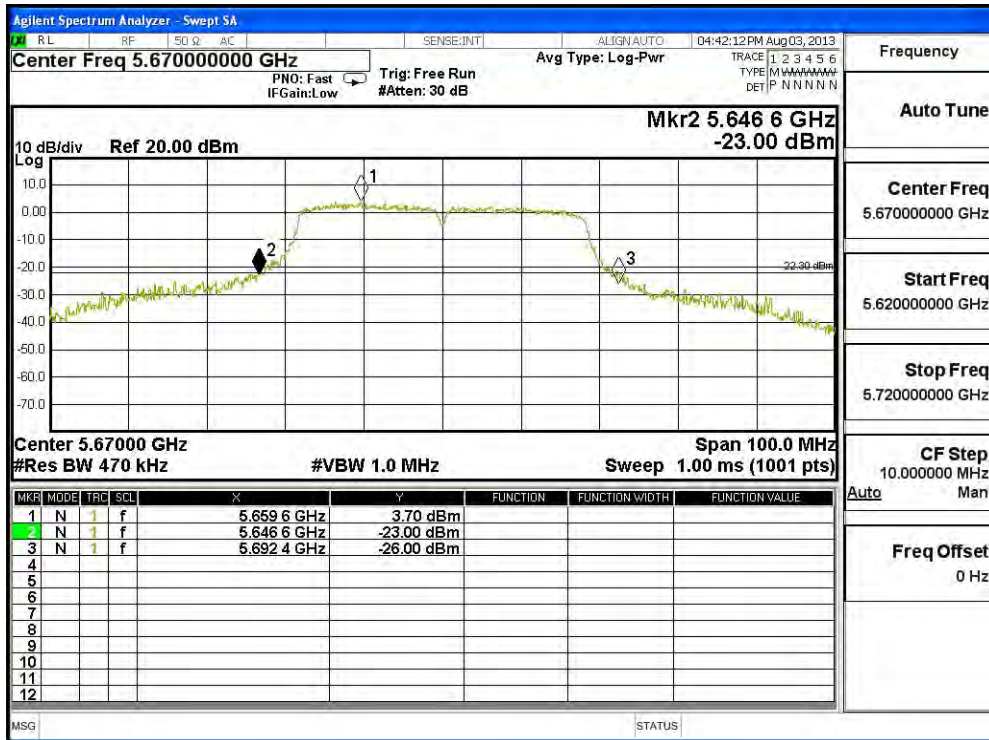

### 26dBc Occupied Bandwidth: Channel 54 – Chain B

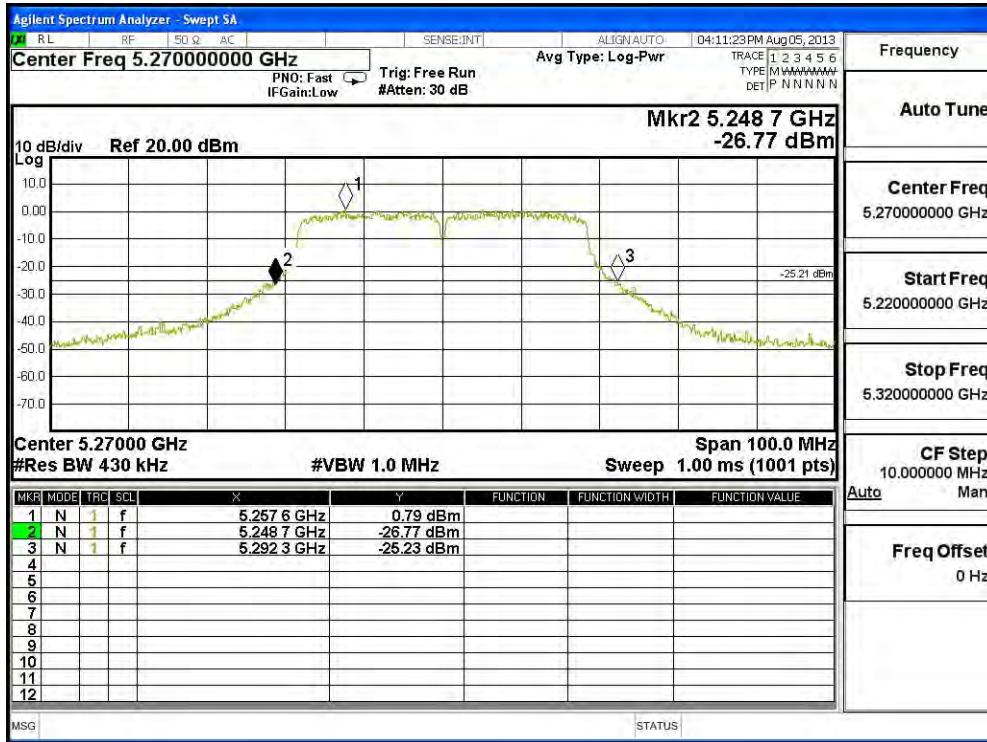

### Channel 62 – Chain B

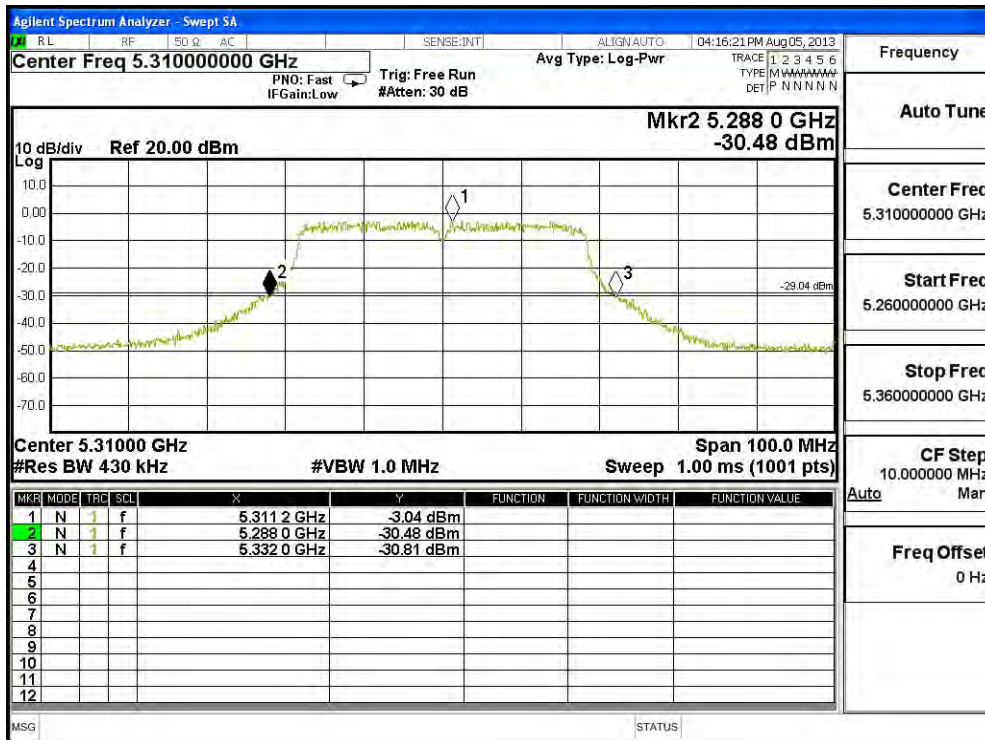



**Channel 102 – Chain B**

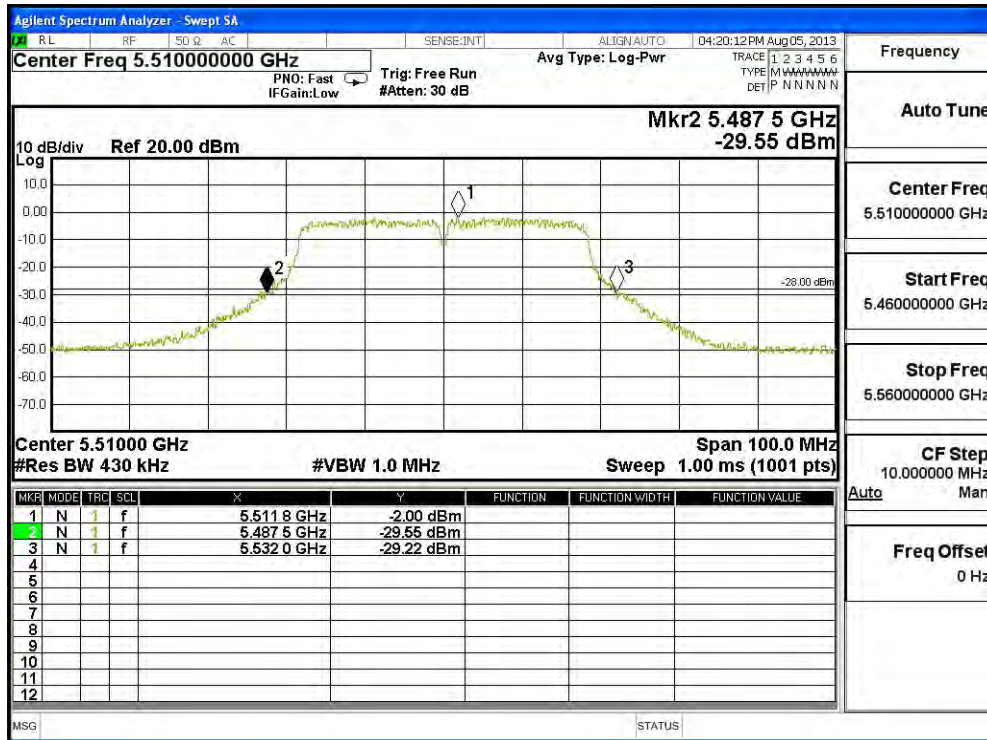

**Channel 110 – Chain B**

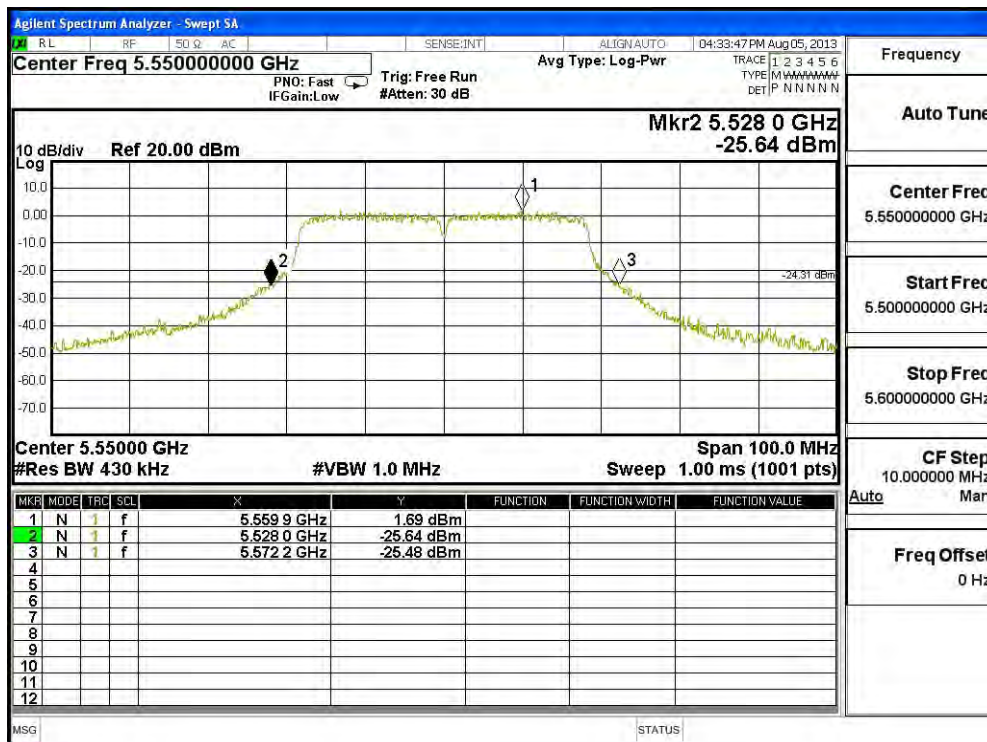

Channel 134 – Chain B

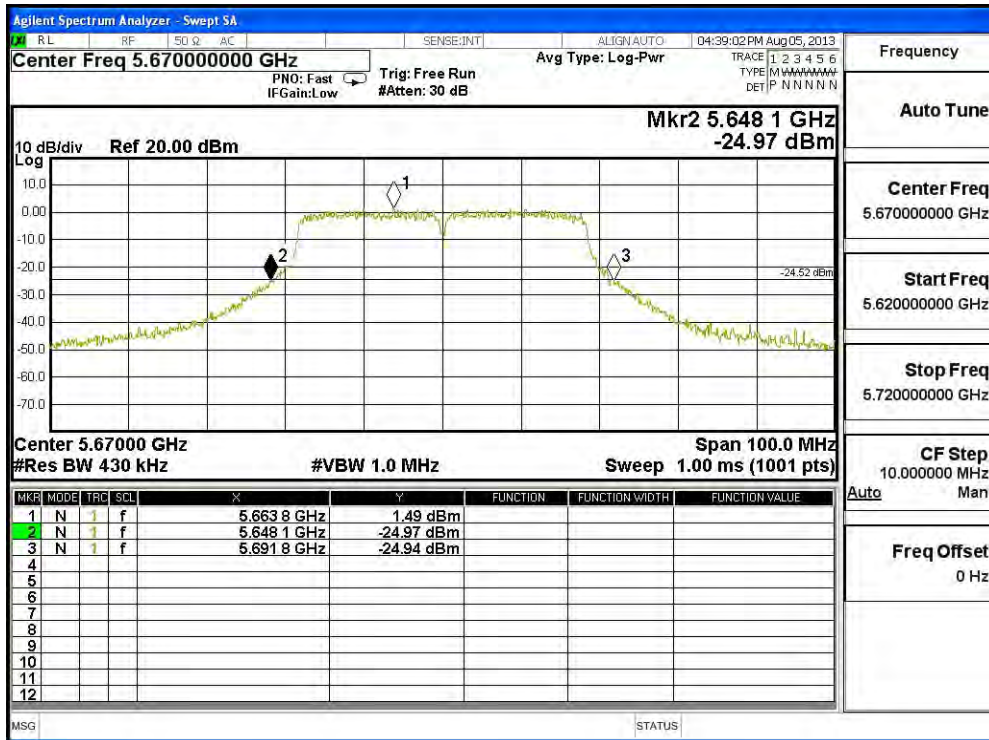

### 26dBc Occupied Bandwidth: Channel 54 – Chain C

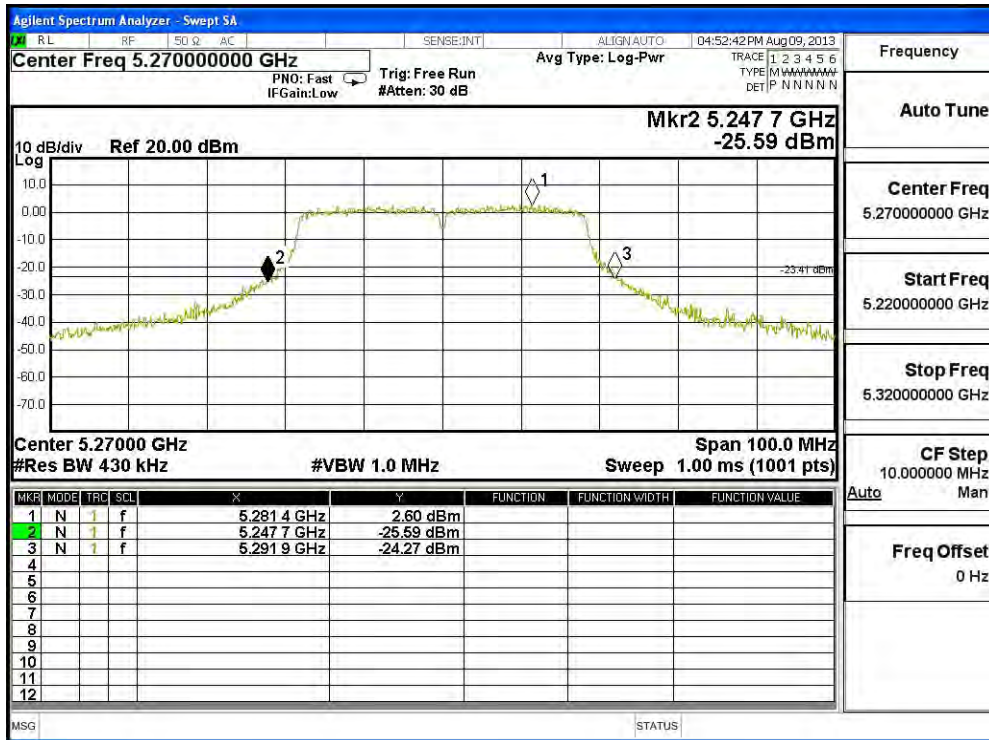

### Channel 62 – Chain C

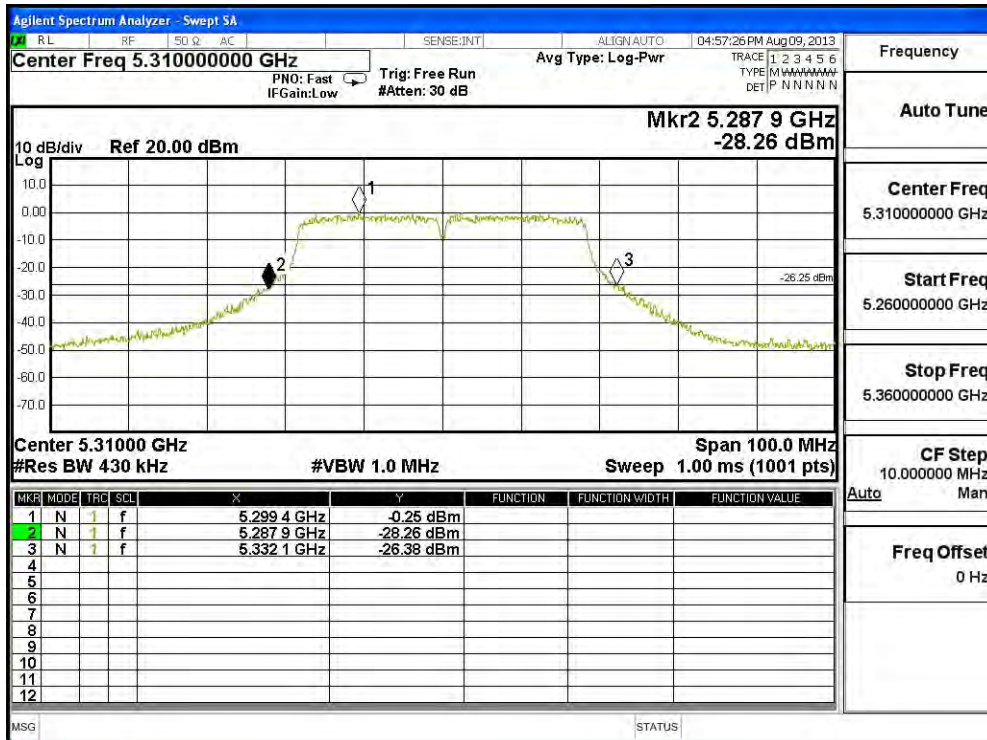

Channel 102 – Chain C

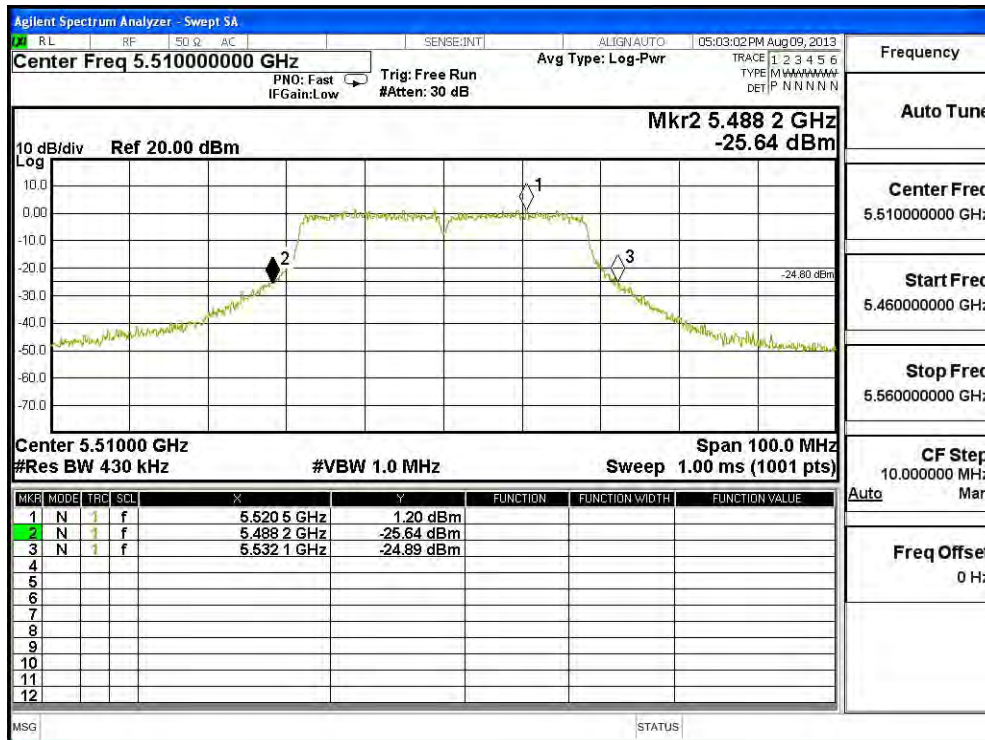

Channel 110 – Chain C

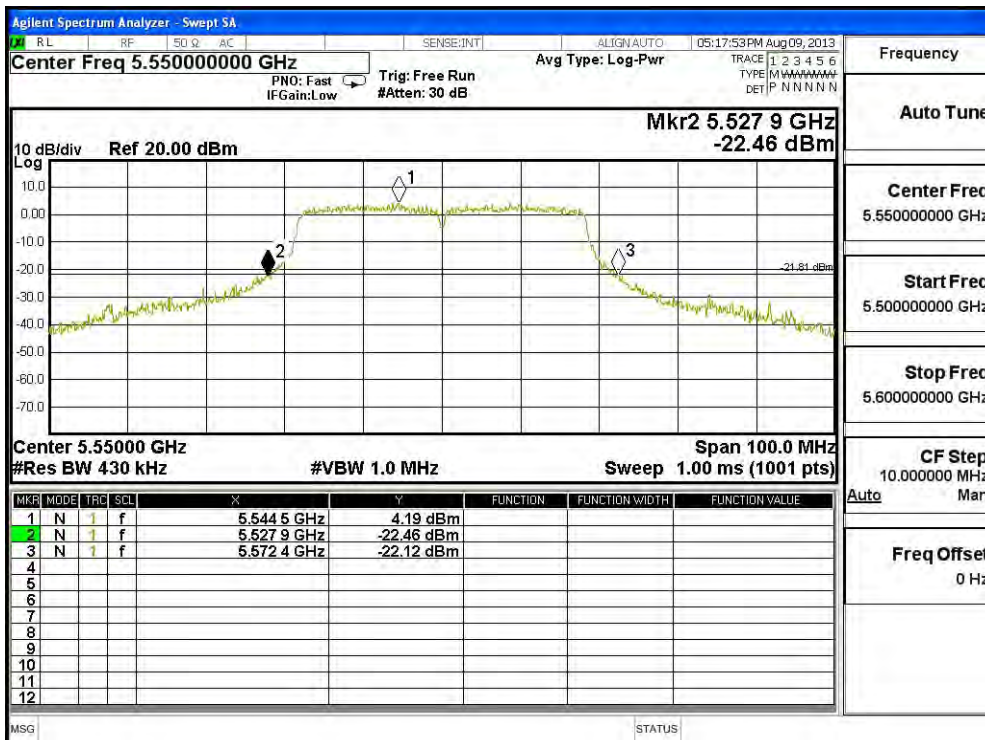

Channel 134 – Chain C

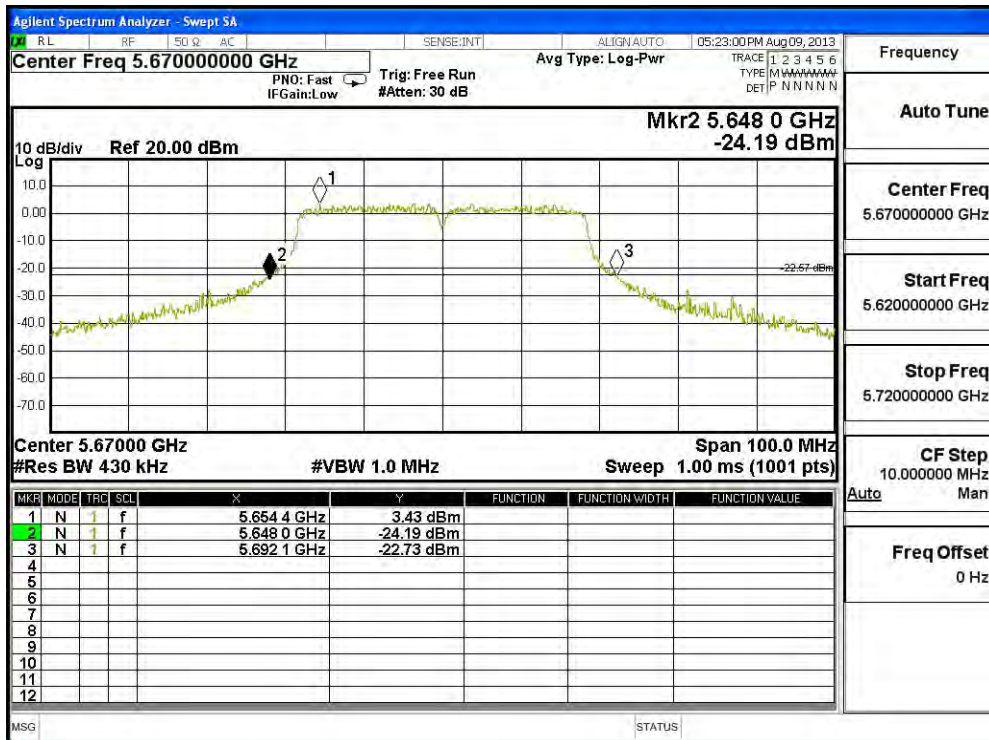

Product : SpectraGuard® Access Point / Sensor  
 Test Item : Maximum conducted output power  
 Test Site : No.3 OATS  
 Test Mode : Mode 4: Transmit (802.11a-6Mbps)(PIFA Antenna)

**CHAIN A**

Cable loss=1dB		Maximum conducted output power								
Channel No.	Frequency (MHz)	Data Rate (Mbps)								Required Limit
		6	9	12	18	24	36	48	54	
		Measurement Level (dBm)								
52	5260	17.22	--	--	--	--	--	--	--	<24dBm
60	5300	17.89	17.76	17.55	17.39	17.22	17.05	16.88	16.71	<24dBm
64	5320	17.24	--	--	--	--	--	--	--	<24dBm
100	5500	17.71	--	--	--	--	--	--	--	<24dBm
116	5580	17.42	17.33	17.17	17.06	16.93	16.81	16.68	16.56	<24dBm
140	5700	17.9	--	--	--	--	--	--	--	<24dBm

Note: 1.Maximum conducted output power Value =Reading value on average power meter + cable loss

**CHAIN B**

Cable loss=1dB		Maximum conducted output power								
Channel No.	Frequency (MHz)	Data Rate (Mbps)								Required Limit
		6	9	12	18	24	36	48	54	
		Measurement Level (dBm)								
52	5260	16.72	--	--	--	--	--	--	--	<24dBm
60	5300	16.46	16.33	16.17	16.03	15.89	15.74	15.60	15.45	<24dBm
64	5320	14.09	--	--	--	--	--	--	--	<24dBm
100	5500	16.67	--	--	--	--	--	--	--	<24dBm
116	5580	16.72	16.57	16.34	16.16	15.97	15.78	15.59	15.40	<24dBm
140	5700	16.51	--	--	--	--	--	--	--	<24dBm

Note: 1.Maximum conducted output power Value =Reading value on average power meter + cable loss

**CHAIN C**

Cable loss=1dB		Maximum conducted output power								
Channel No.	Frequency (MHz)	Data Rate (Mbps)								Required Limit
		6	9	12	18	24	36	48	54	
		Measurement Level (dBm)								
52	5260	17.71	--	--	--	--	--	--	--	<24dBm
60	5300	17.06	16.91	16.79	16.65	16.52	16.38	16.25	16.11	<24dBm
64	5320	15.43	--	--	--	--	--	--	--	<24dBm
100	5500	17.39	--	--	--	--	--	--	--	<24dBm
116	5580	17.78	17.66	17.49	17.35	17.21	17.06	16.92	16.77	<24dBm
140	5700	17.02	--	--	--	--	--	--	--	<24dBm

Note: 1. Maximum conducted output power Value = Reading value on average power meter + cable loss

**Maximum conducted output power Measurement:**
**(CHAIN A+ B+C)**

Channel Number	Frequency (MHz)	26dB Bandwidth (MHz)	Chain A Power (dBm)	Chain B Power (dBm)	Chain C Power (dBm)	Output Power (dBm)	Output Power Limit	
							(dBm)	dBm+10log(BW)
52	5260	23.800	17.22	16.72	17.71	22.01	24	24.77
60	5300	23.200	17.89	16.46	17.06	21.95	24	24.65
64	5320	23.850	17.24	14.09	15.43	20.55	24	24.77
100	5500	23.250	17.71	16.67	17.39	22.05	24	24.66
116	5580	24.150	17.42	16.72	17.78	22.10	24	24.83
140	5700	23.050	17.90	16.51	17.02	21.95	24	24.63

Note:

1. Power Output Value = Reading value on average power meter + cable loss
2. Output Power (dBm) = 10LOG (Chain A Power (mW)+ Chain B Power (mW))
3. 26 dB Bandwidth is the bandwidth of chain A or chain B whichever is less bandwidth, output power limitation is more stringent.

**26dBc Occupied Bandwidth:  
Channel 52: CHAIN A**

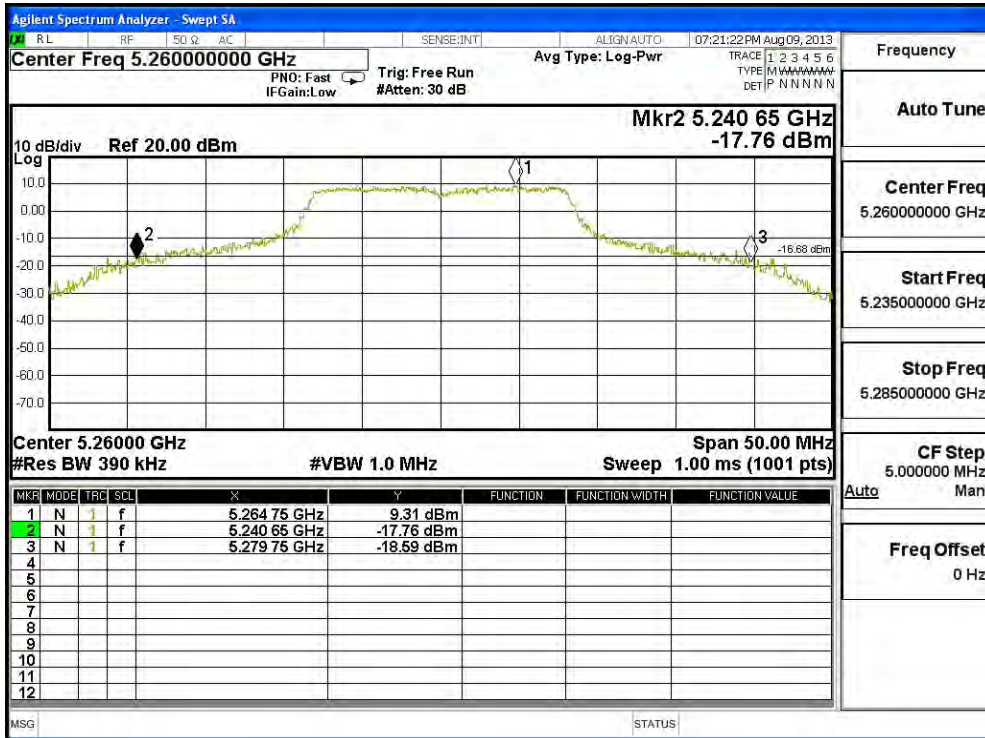

**Channel 60: CHAIN A**

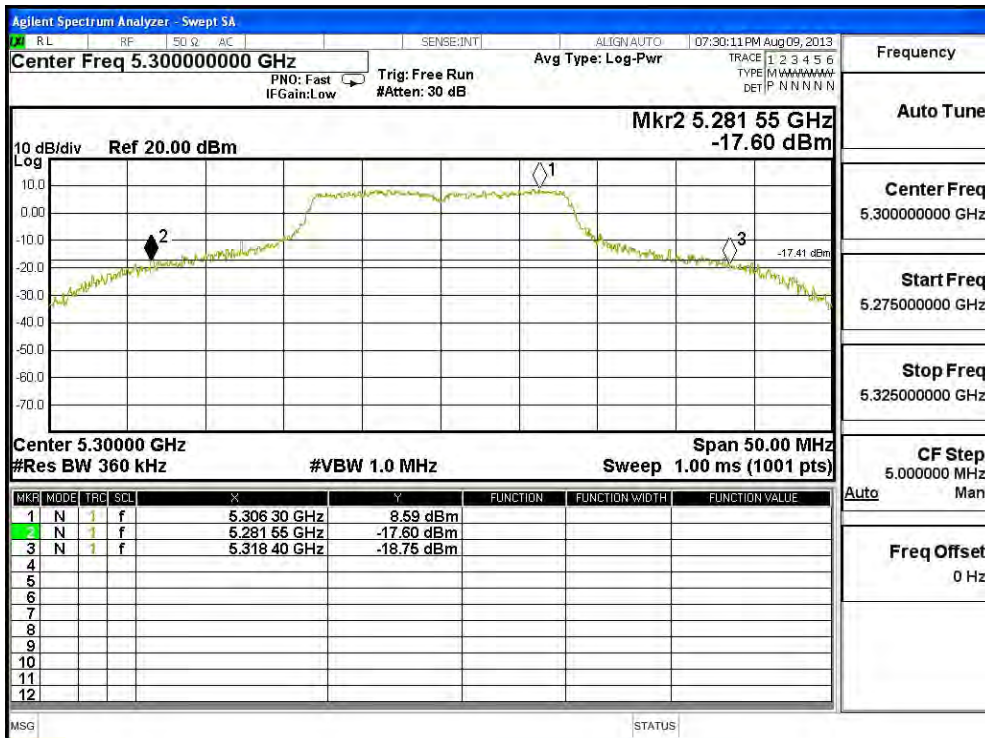



Channel 64: CHAIN A

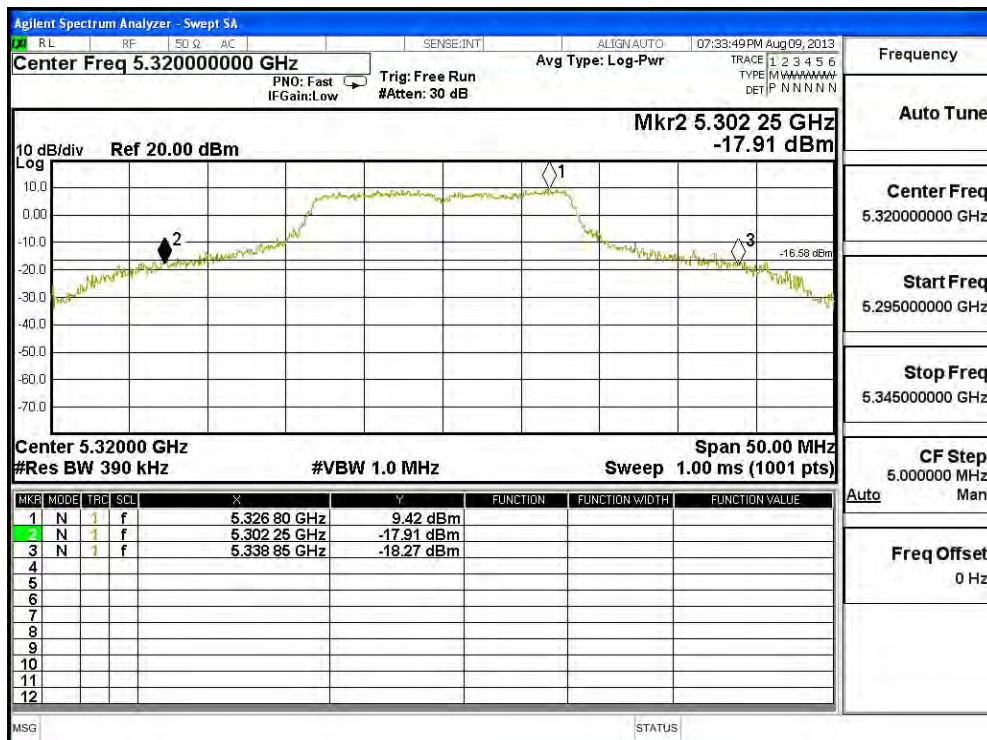

Channel 100: CHAIN A

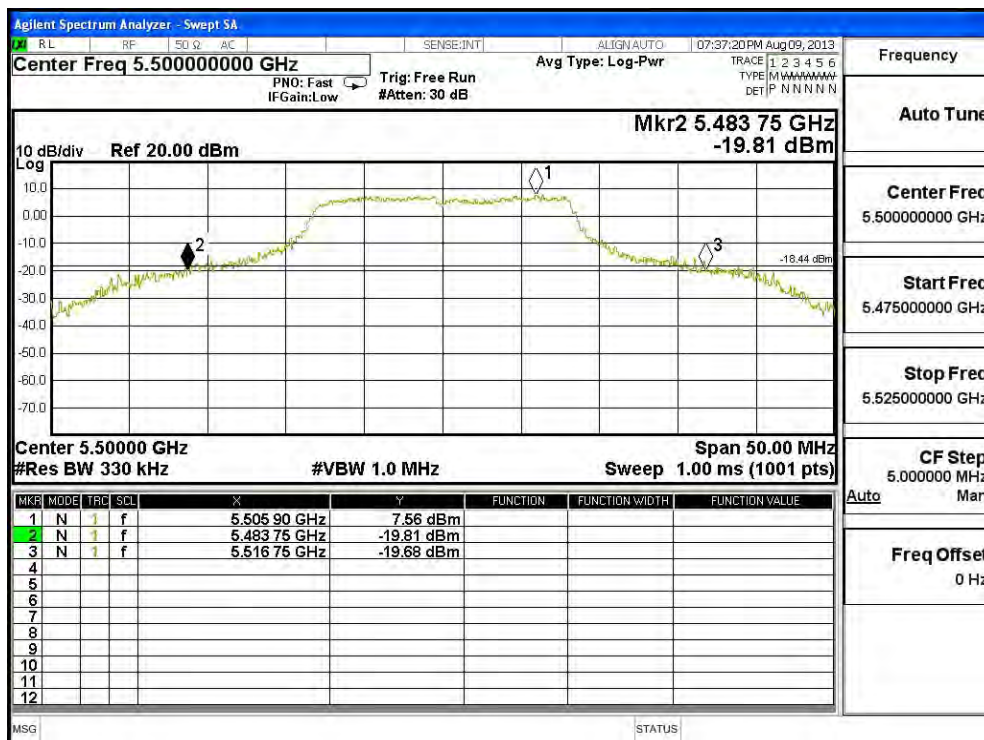

**Channel 120: CHAIN A**

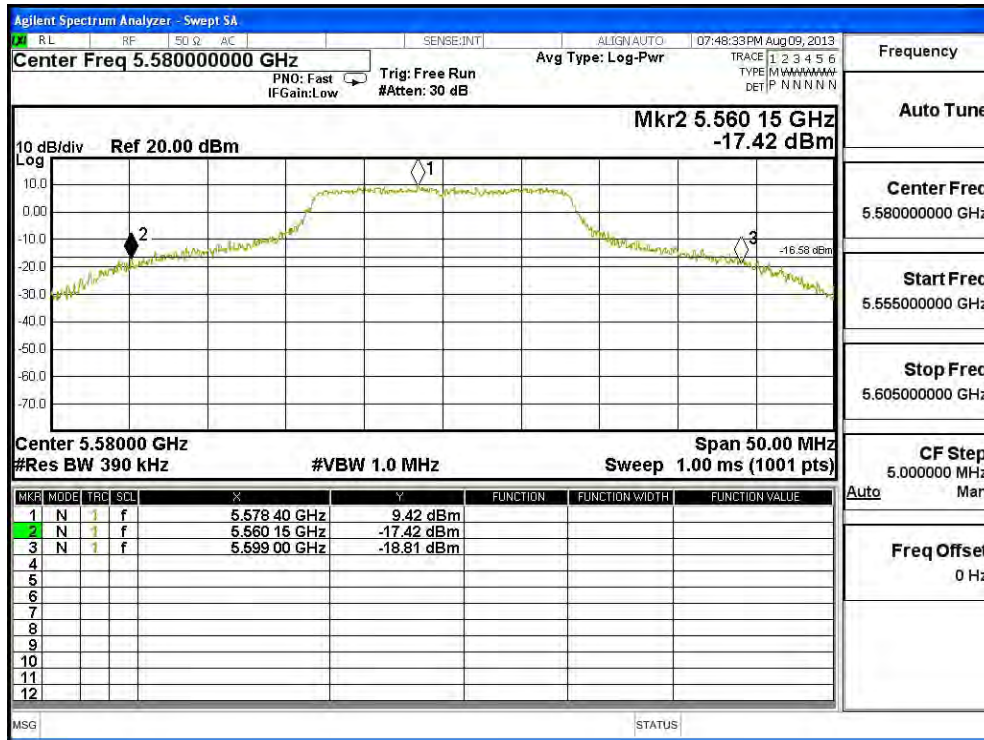

**Channel 140: CHAIN A**

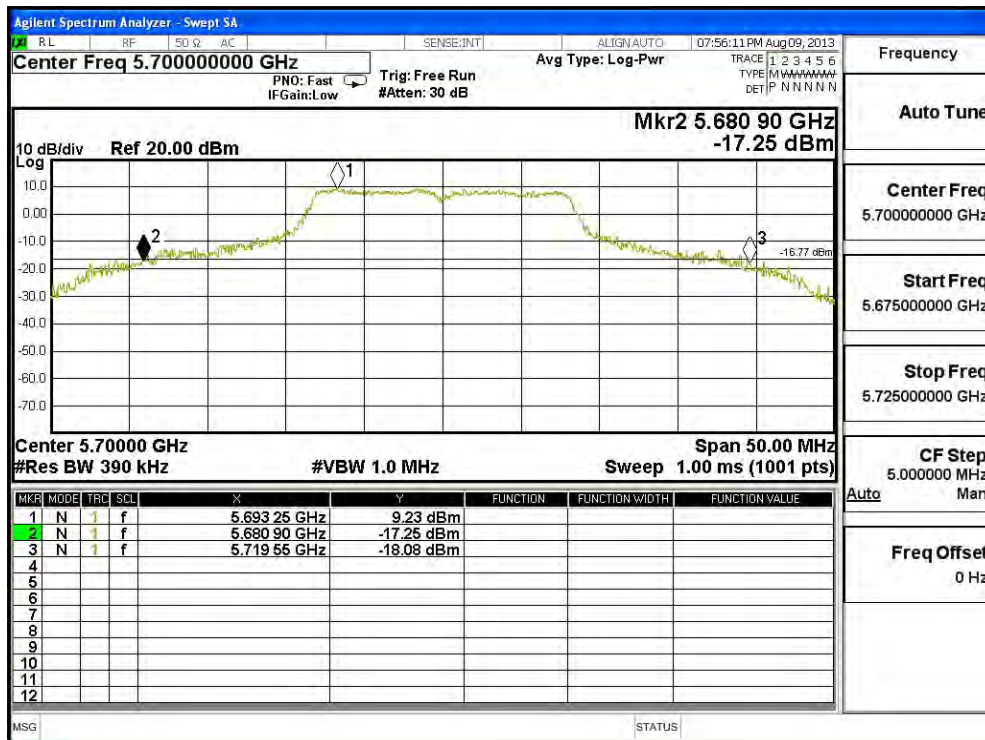

**26dBc Occupied Bandwidth:  
Channel 52: CHAIN B**

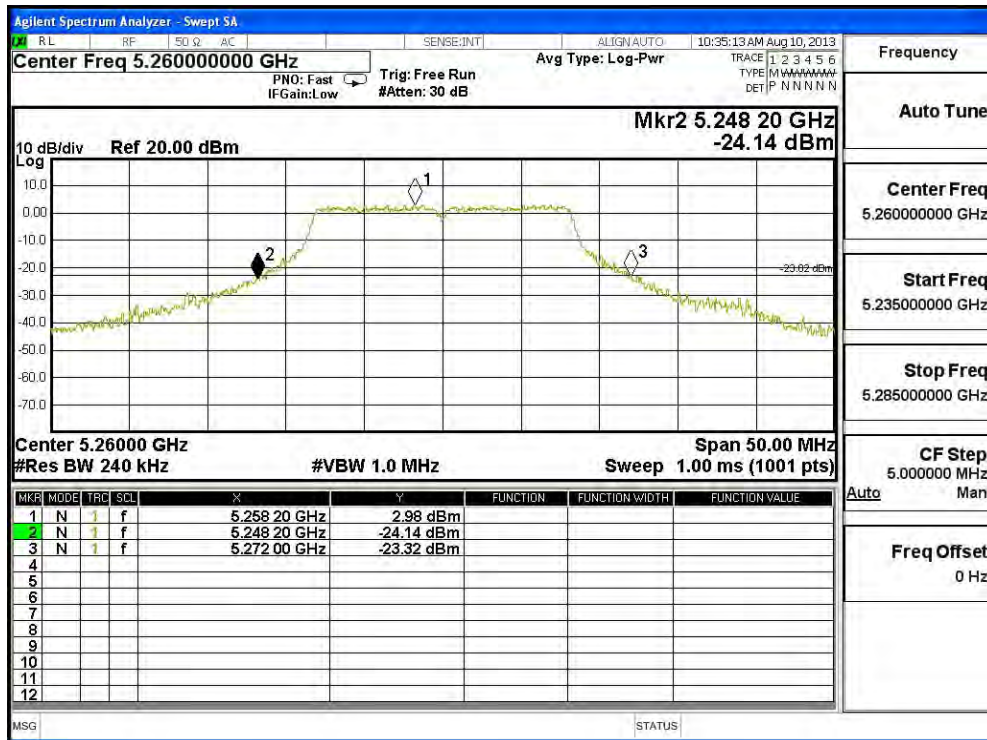

**Channel 60: CHAIN B**

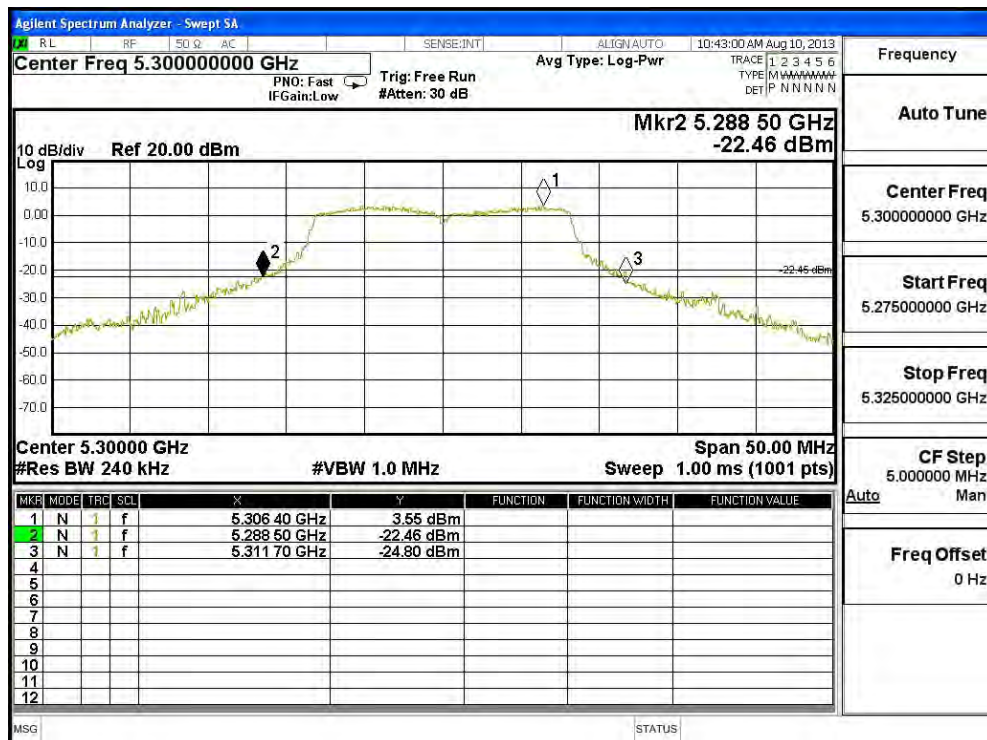

Channel 64: CHAIN B

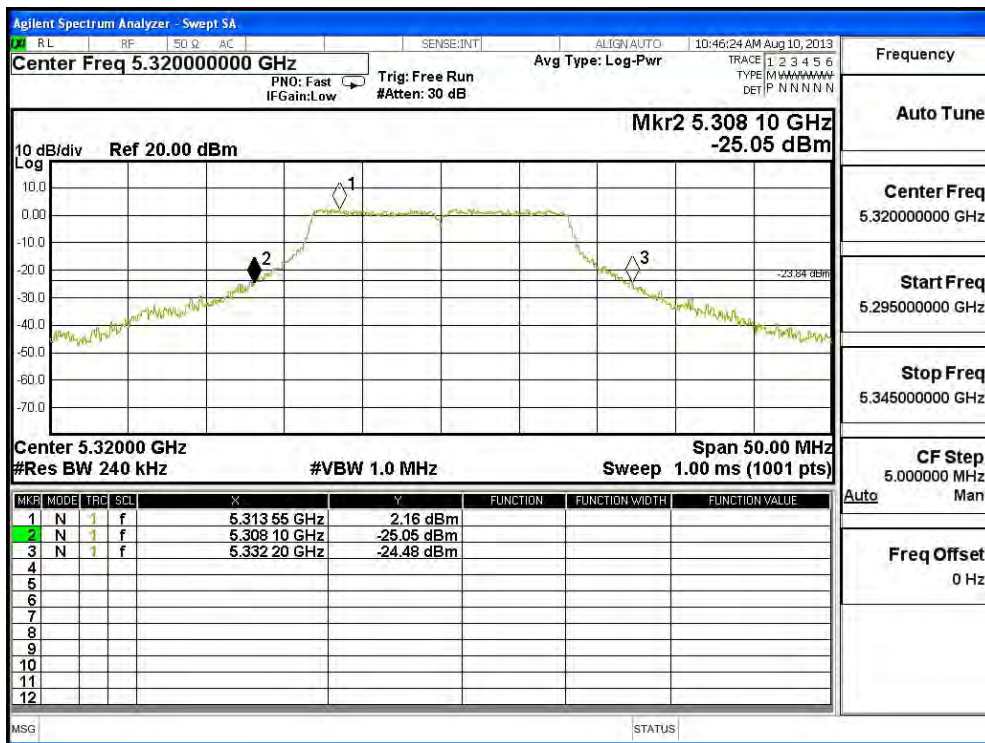

Channel 100: CHAIN B

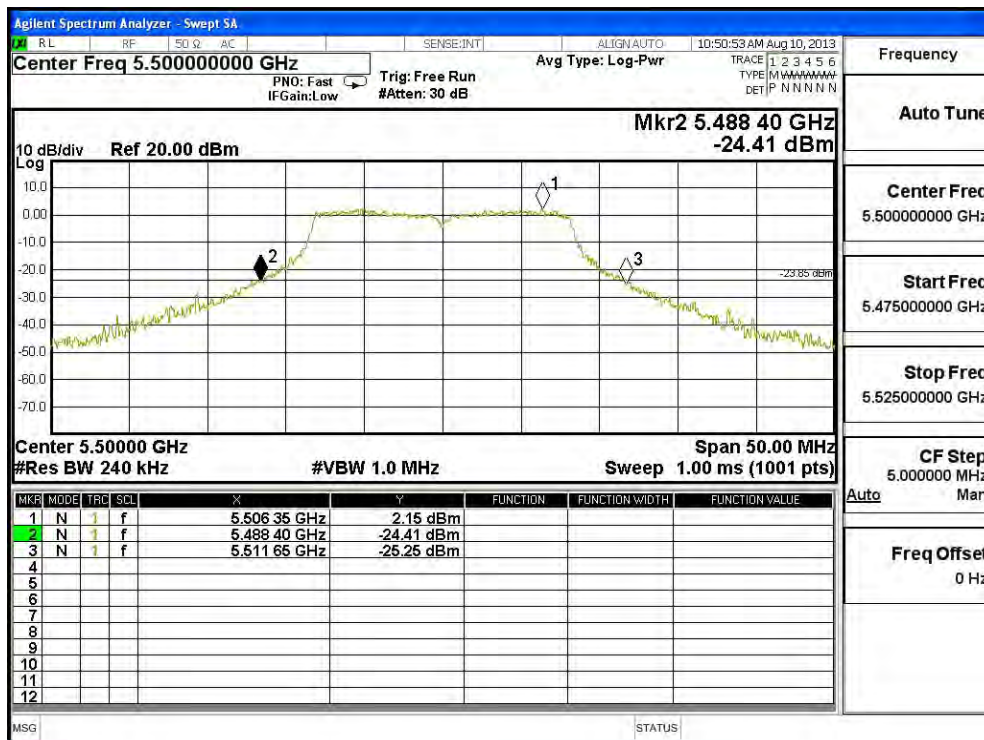

**Channel 120: CHAIN B**

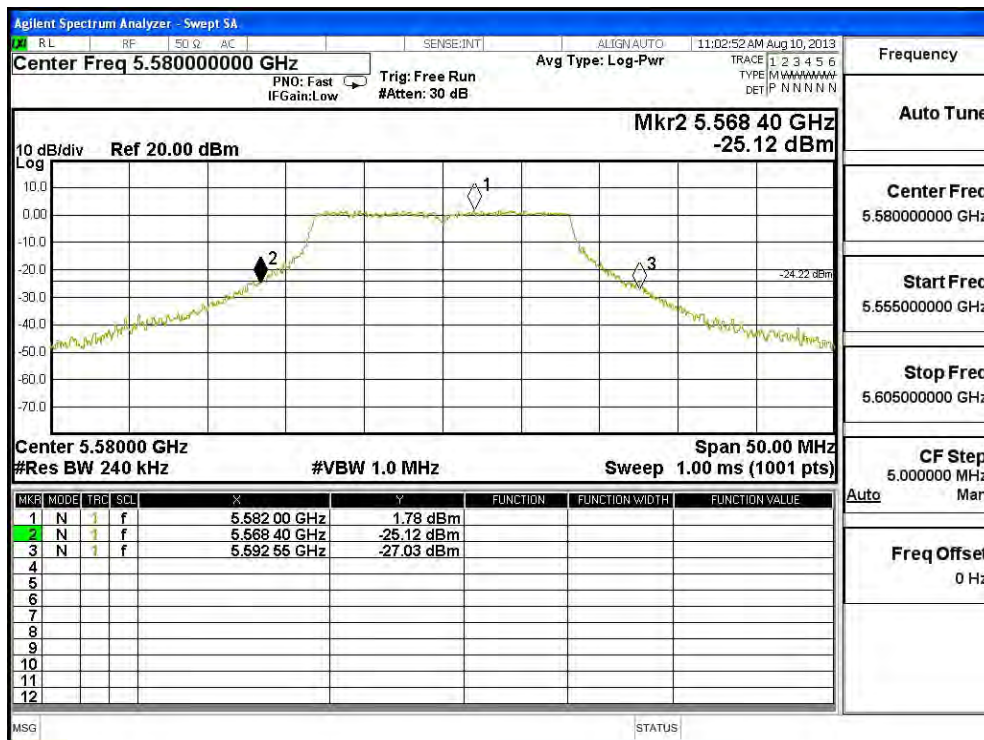

**Channel 140: CHAIN B**

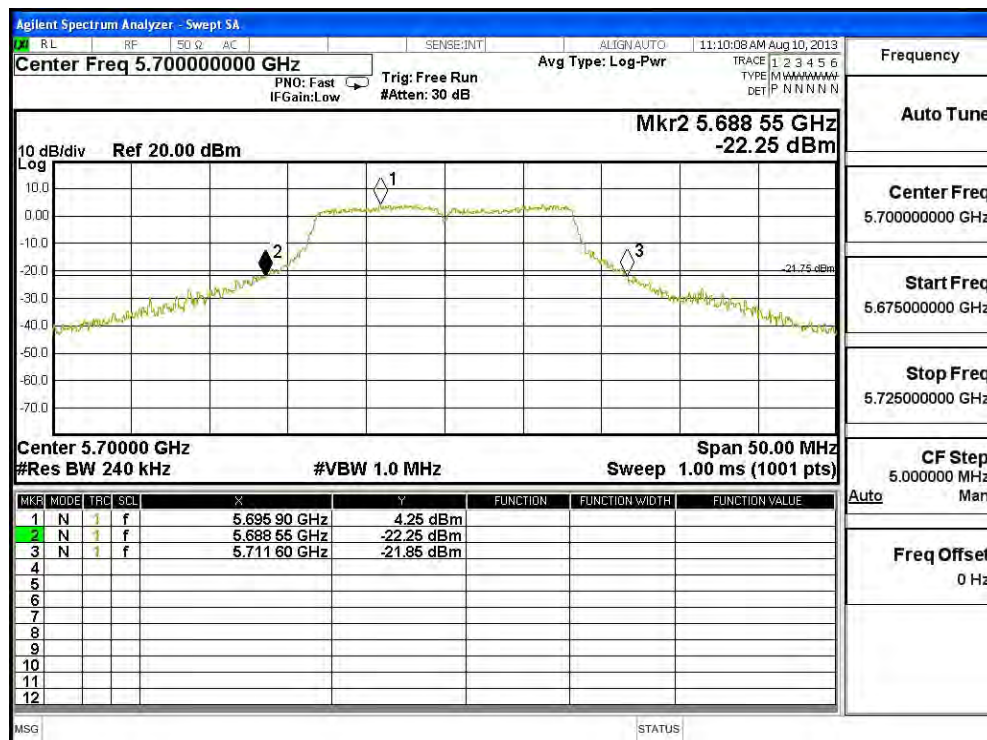

**26dBc Occupied Bandwidth:  
Channel 52: CHAIN C**

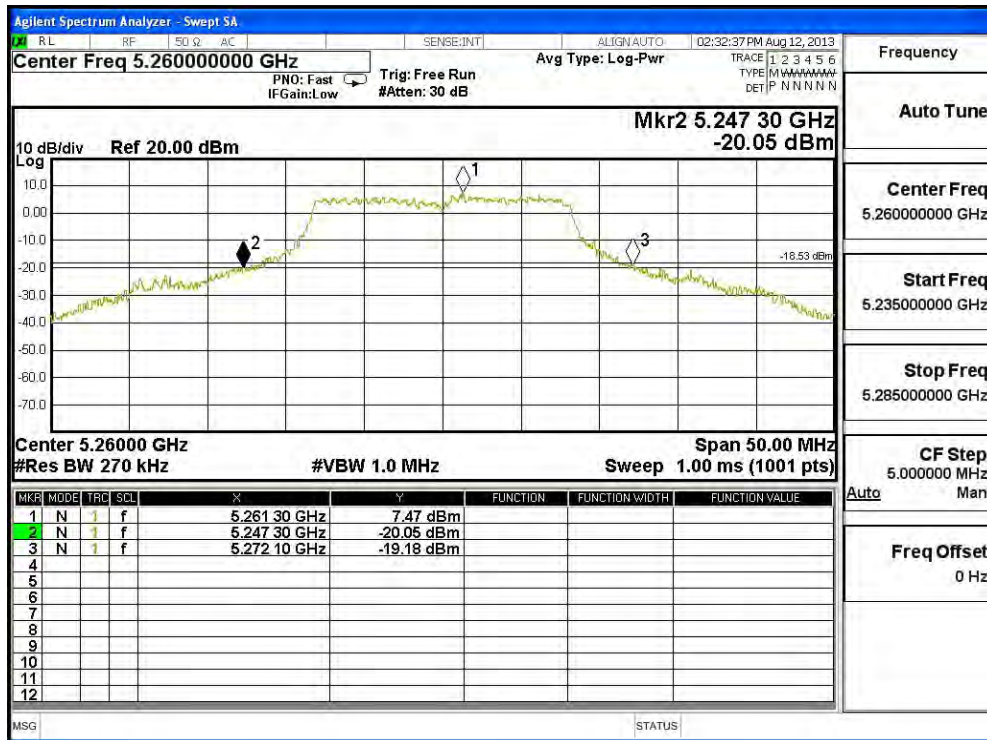

**Channel 60: CHAIN C**

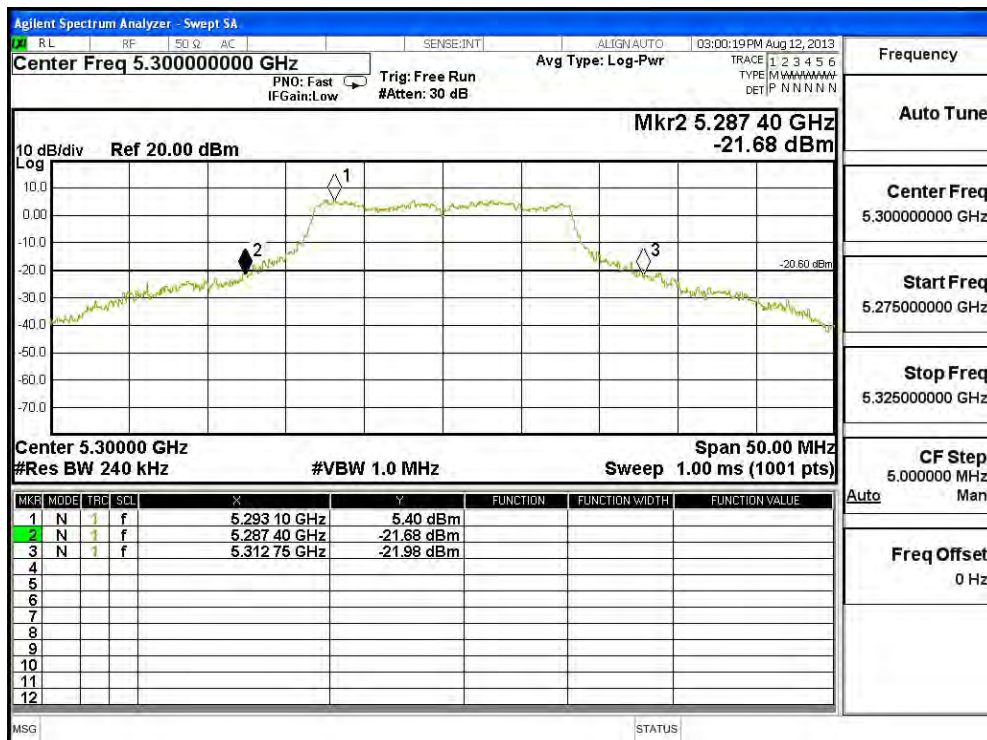

**Channel 64: CHAIN C**

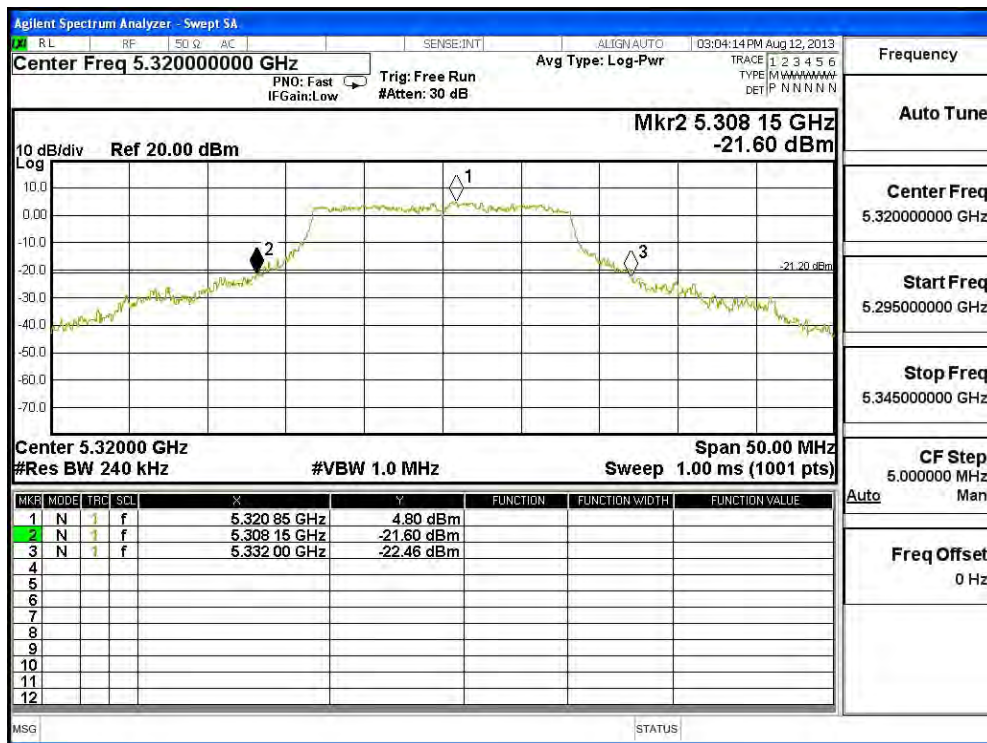

**Channel 100: CHAIN C**

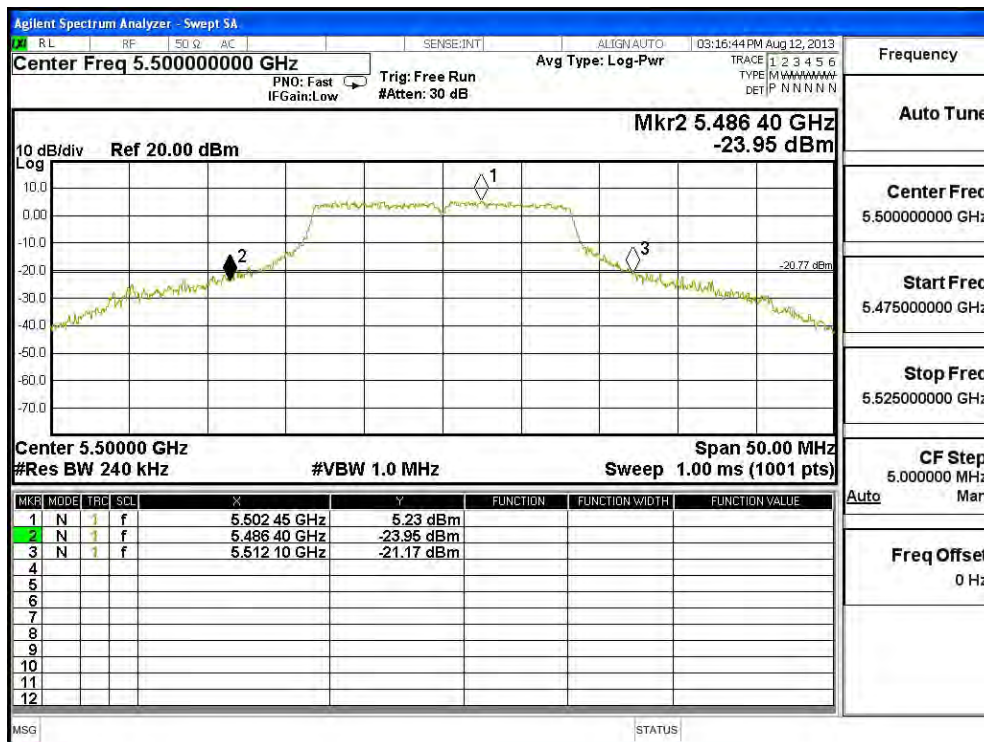

**Channel 120: CHAIN C**

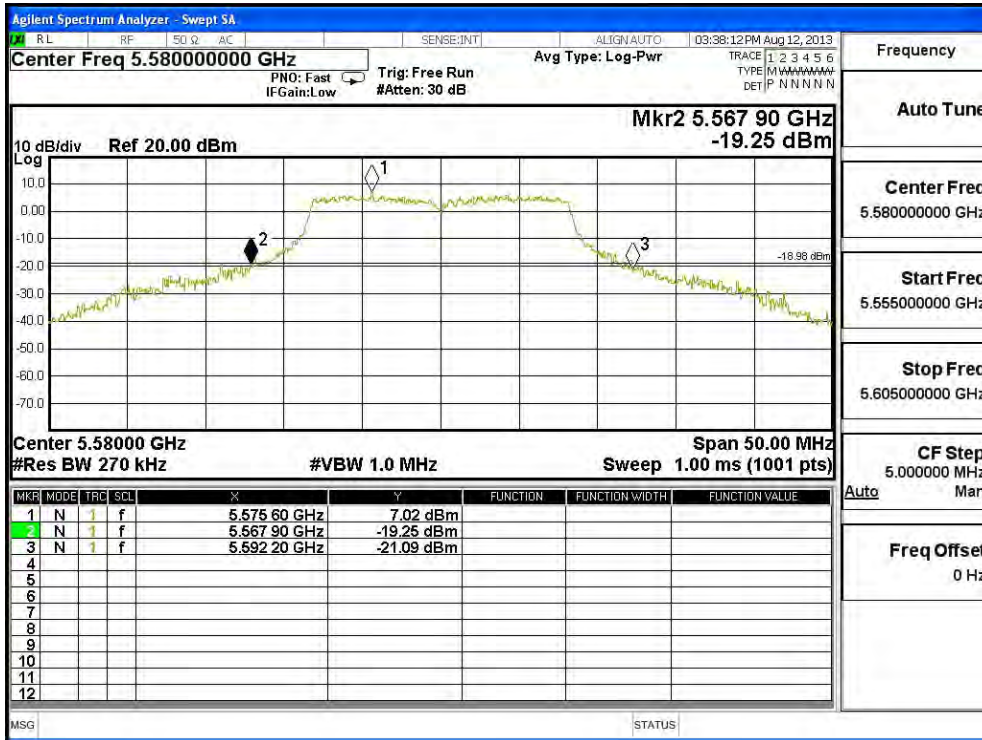

**Channel 140: CHAIN C**

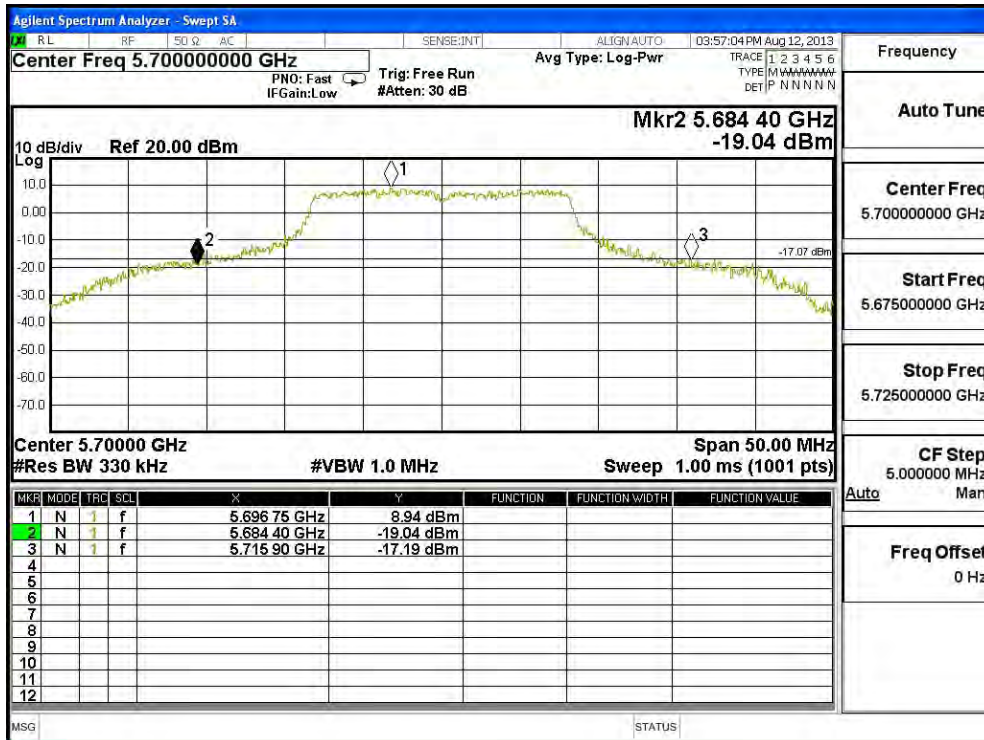



Product : SpectraGuard® Access Point / Sensor  
 Test Item : Maximum conducted output power  
 Test Site : No.3 OATS  
 Test Mode : Mode 5: Transmit (802.11n-20BW 21.7Mbps)(PIFA Antenna)

**CHAIN A**

Cable loss=1dB		Maximum conducted output power								
Channel No.	Frequency (MHz)	Data Rate (Mbps)								Required Limit
		21.7	43.3	65	86.7	130	173.3	195	216.7	
		Measurement Level (dBm)								
52	5260	18.01	--	--	--	--	--	--	--	<24dBm
60	5300	17.9	17.77	17.56	17.40	17.23	17.06	16.89	16.72	<24dBm
64	5320	17.41	--	--	--	--	--	--	--	<24dBm
100	5500	17.71	--	--	--	--	--	--	--	<24dBm
116	5580	18.55	18.41	18.3	18.17	18.05	17.92	17.80	17.67	<24dBm
140	5700	17.71	--	--	--	--	--	--	--	<24dBm

Note: 1.Maximum conducted output power Value =Reading value on average power meter + cable loss

**CHAIN B**

Cable loss=1dB		Maximum conducted output power								
Channel No.	Frequency (MHz)	Data Rate (Mbps)								Required Limit
		21.7	43.3	65	86.7	130	173.3	195	216.7	
		Measurement Level (dBm)								
52	5260	15.82	--	--	--	--	--	--	--	<24dBm
60	5300	16.73	16.62	16.44	16.31	16.16	16.02	15.87	15.73	<24dBm
64	5320	15.66	--	--	--	--	--	--	--	<24dBm
100	5500	16.20	--	--	--	--	--	--	--	<24dBm
116	5580	16.01	15.89	15.74	15.61	15.48	15.34	15.21	15.07	<24dBm
140	5700	16.53	--	--	--	--	--	--	--	<24dBm

Note: 1.Maximum conducted output power Value =Reading value on average power meter + cable loss

**CHAIN C**

Cable loss=1dB		Maximum conducted output power								
Channel No.	Frequency (MHz)	Data Rate (Mbps)								Required Limit
		21.7	43.3	65	86.7	130	173.3	195	216.7	
		Measurement Level (dBm)								
52	5260	17.58	--	--	--	--	--	--	--	<24dBm
60	5300	18.37	18.21	18.08	17.93	17.79	17.64	17.50	17.35	<24dBm
64	5320	16.51	--	--	--	--	--	--	--	<24dBm
100	5500	17.67	--	--	--	--	--	--	--	<24dBm
116	5580	17.36	17.22	17.07	16.93	16.78	16.64	16.49	16.35	<24dBm
140	5700	17.59	--	--	--	--	--	--	--	<24dBm

Note: 1. Maximum conducted output power Value = Reading value on average power meter + cable loss

**Maximum conducted output power Measurement:**
**(CHAIN A+ B+C)**

Channel Number	Frequency (MHz)	26dB Bandwidth (MHz)	Chain A Power (dBm)	Chain B Power (dBm)	Chain C Power (dBm)	Output Power (dBm)	Output Power Limit	
							(dBm)	dBm+10log(BW)
52	5260	24.850	18.01	15.82	17.58	22.01	24	24.95
60	5300	24.100	17.90	16.73	18.37	22.49	24	24.82
64	5320	23.800	17.41	15.66	16.51	21.36	24	24.77
100	5500	24.200	17.71	16.20	17.67	22.02	24	24.84
116	5580	23.850	18.55	16.01	17.36	22.20	24	24.77
140	5700	24.500	17.71	16.53	17.59	22.08	24	24.89

Note:

1. Power Output Value = Reading value on average power meter + cable loss
2. Output Power (dBm) = 10LOG (Chain A Power (mW)+ Chain B Power (mW) + Chain C Power (mW))
3. 26 dB Bandwidth is the bandwidth of chain A or chain B whichever is less bandwidth, output power limitation is more stringent.

**26dBc Occupied Bandwidth:  
Channel 52 -Chain A**

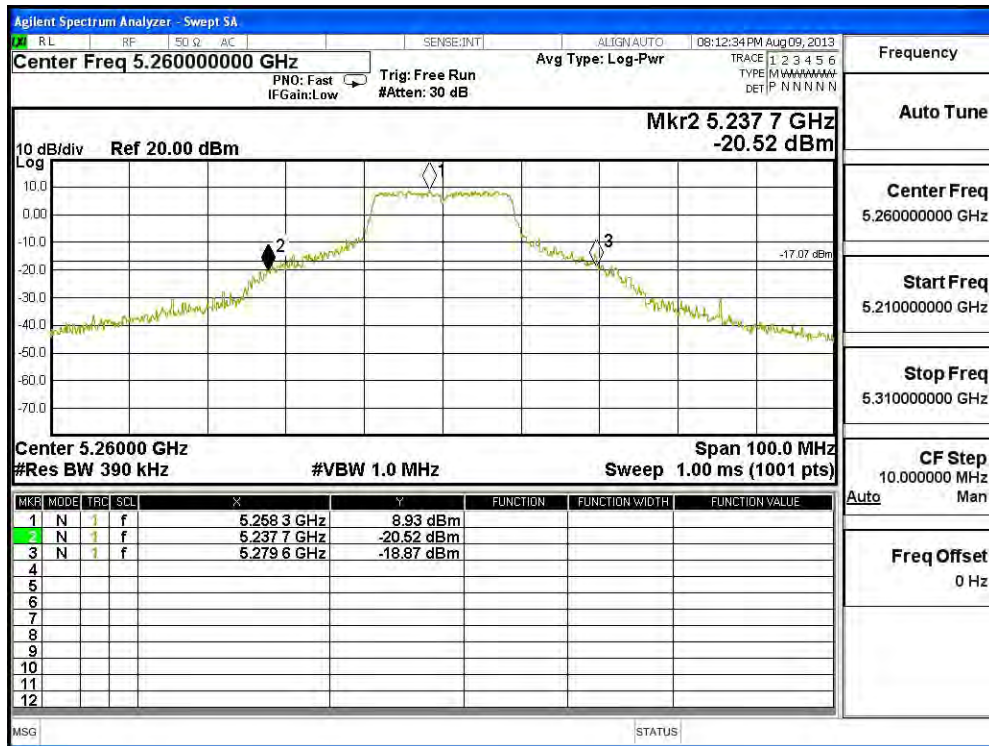

**Channel 60 -Chain A**

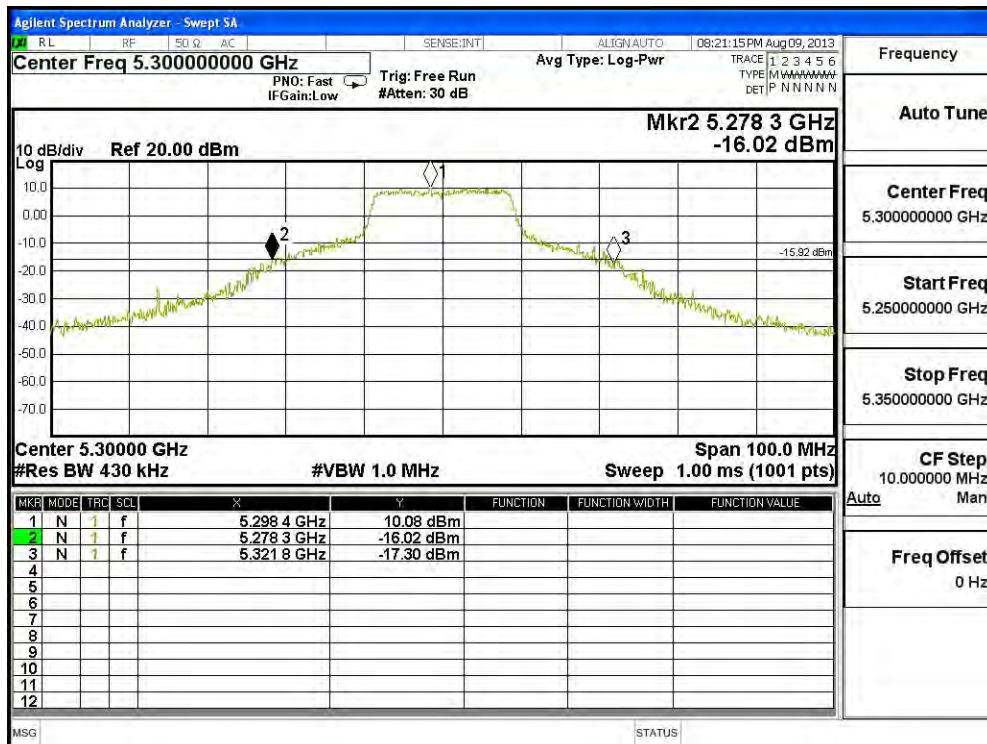

**Channel 64 -Chain A**

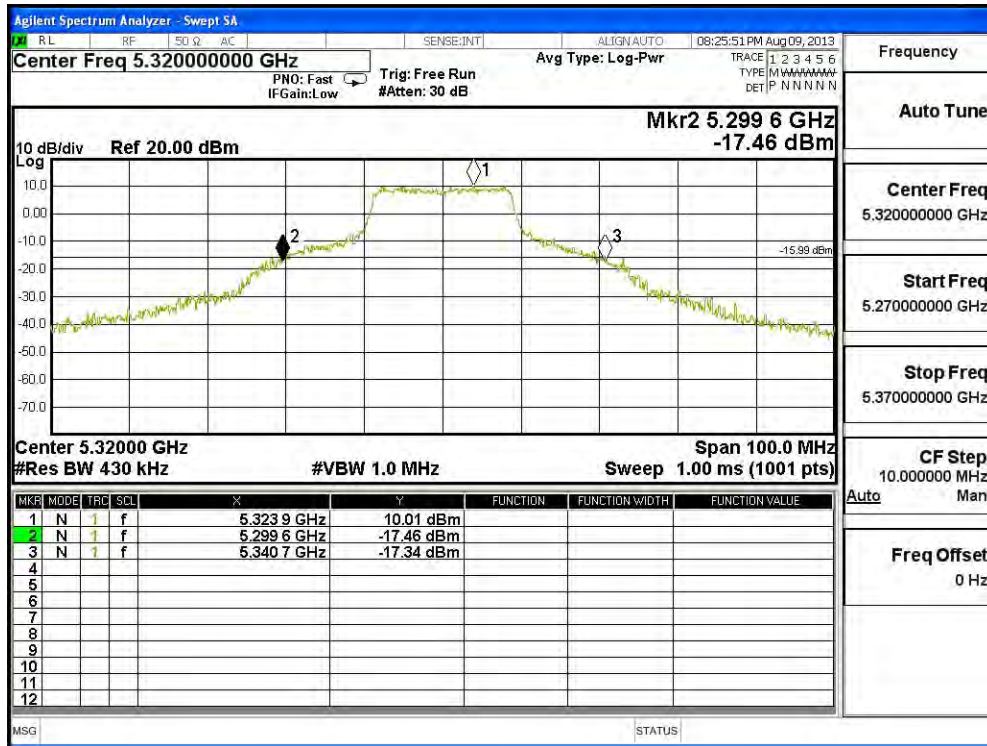

**Channel 100 -Chain A**

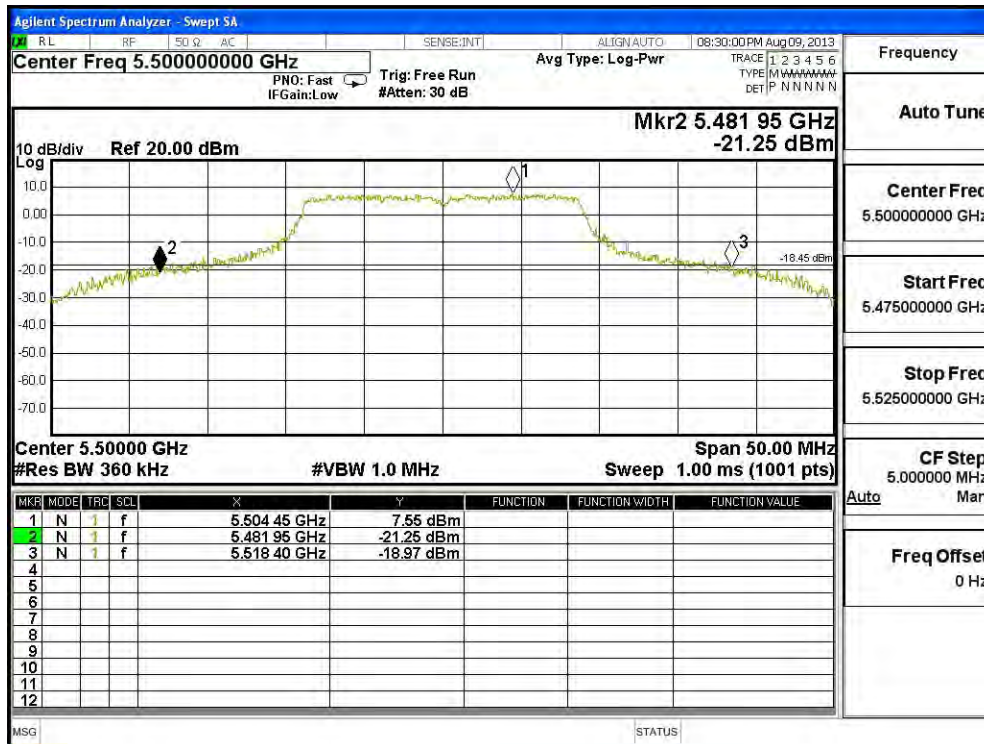

### Channel 120 -Chain A

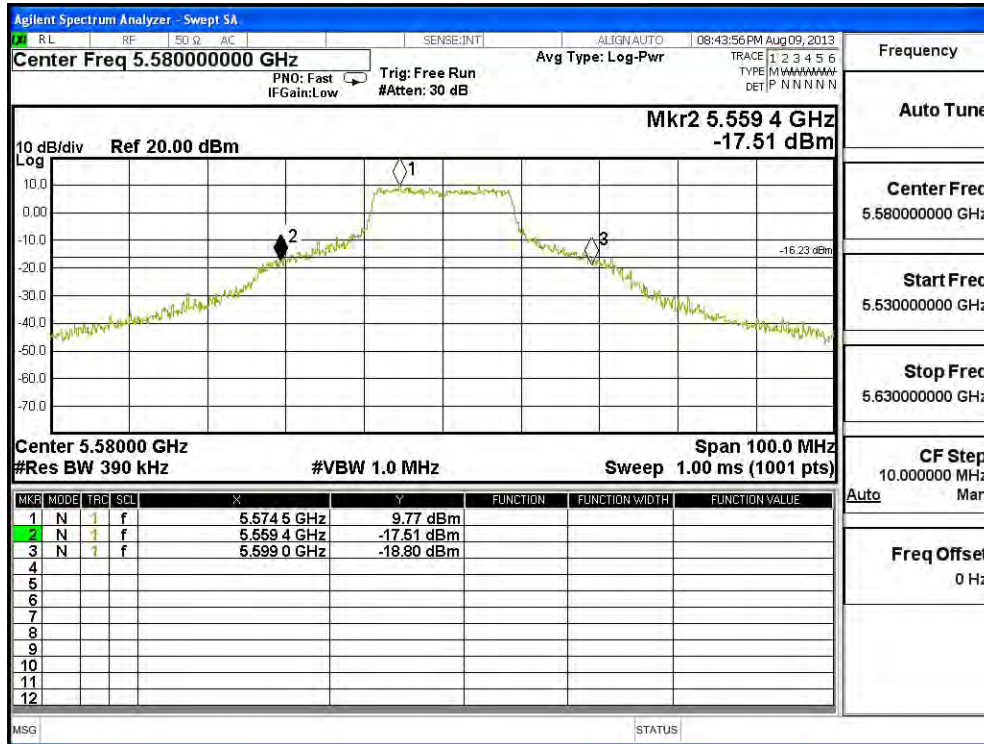

### Channel 140 -Chain A

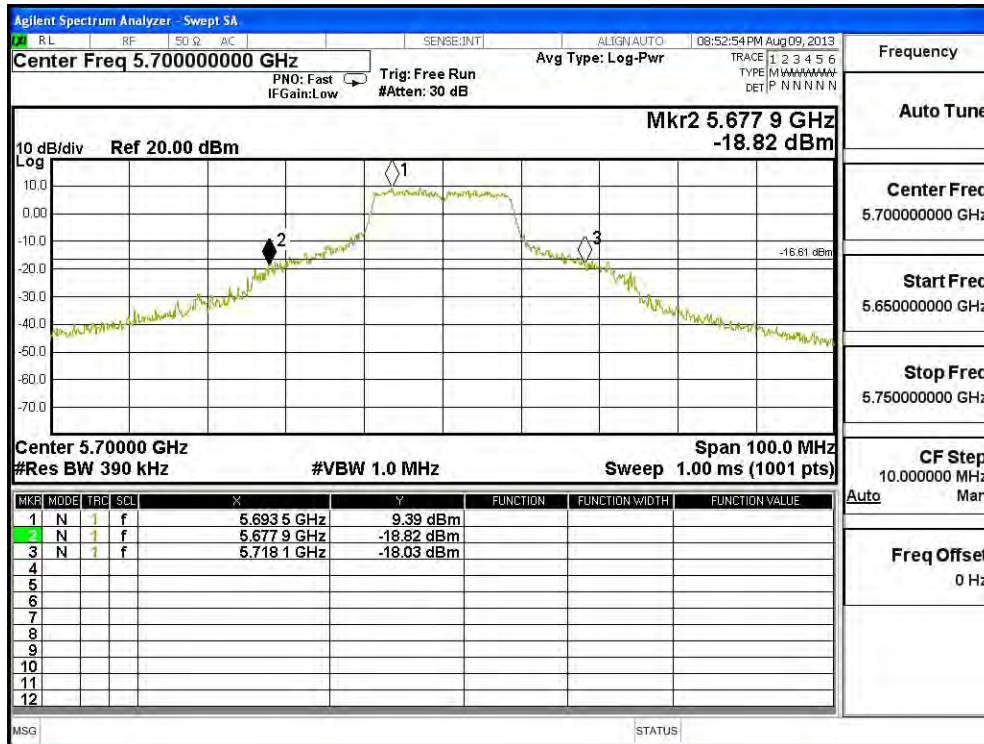

### 26dBc Occupied Bandwidth: Channel 52 -Chain B

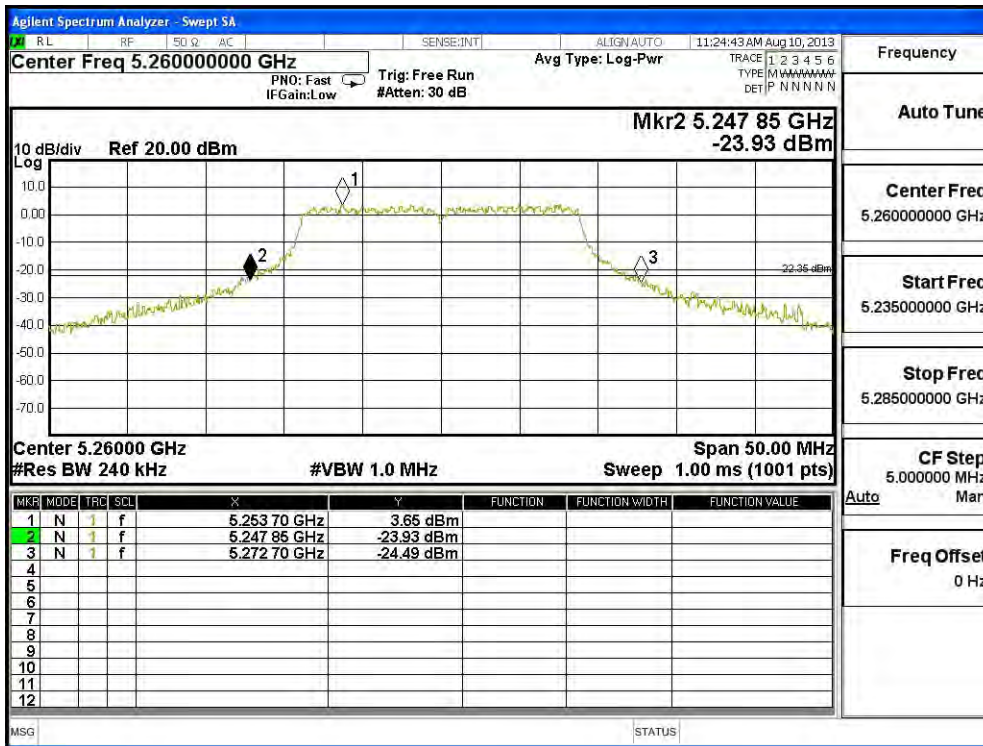

### Channel 60 -Chain B

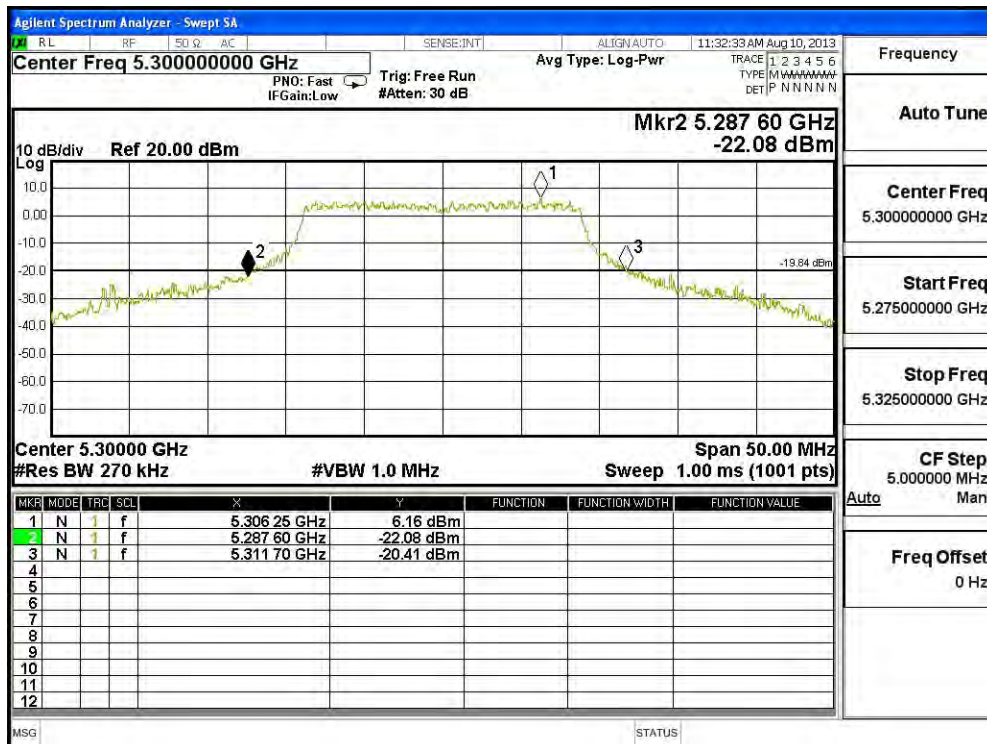

**Channel 64 -Chain B**

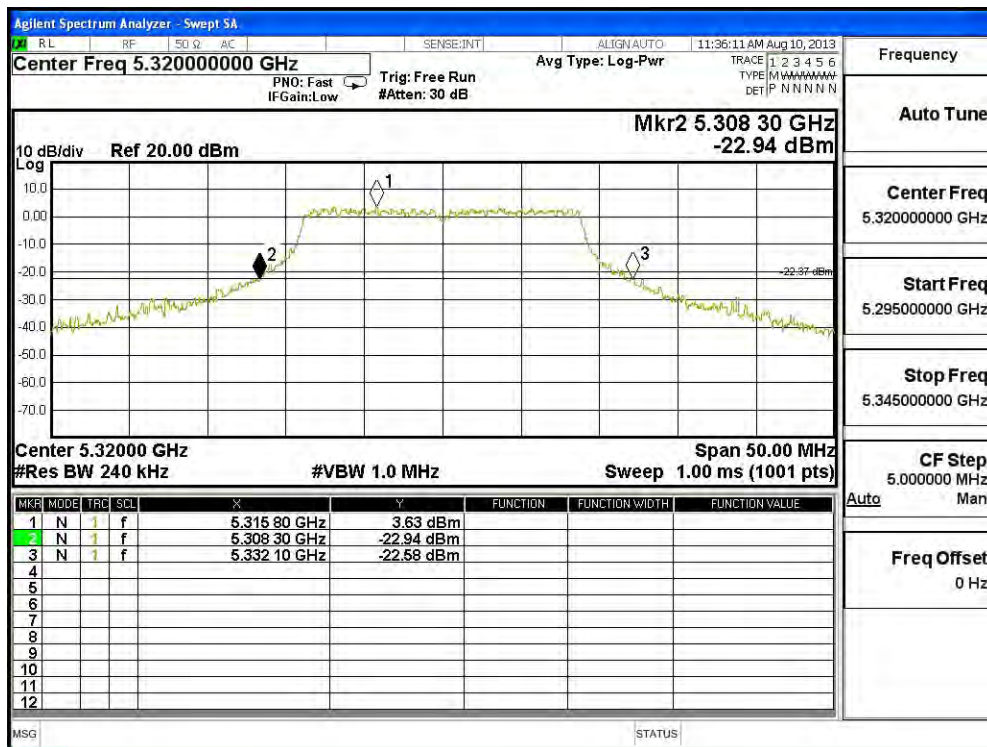

**Channel 100 -Chain B**

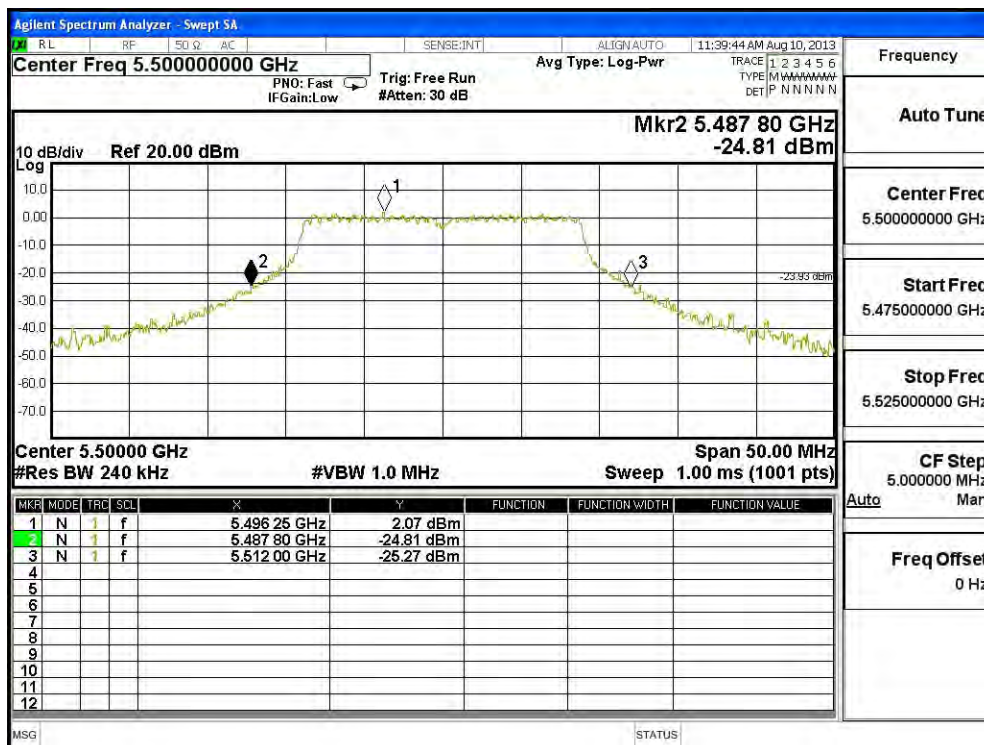

### Channel 120 -Chain B

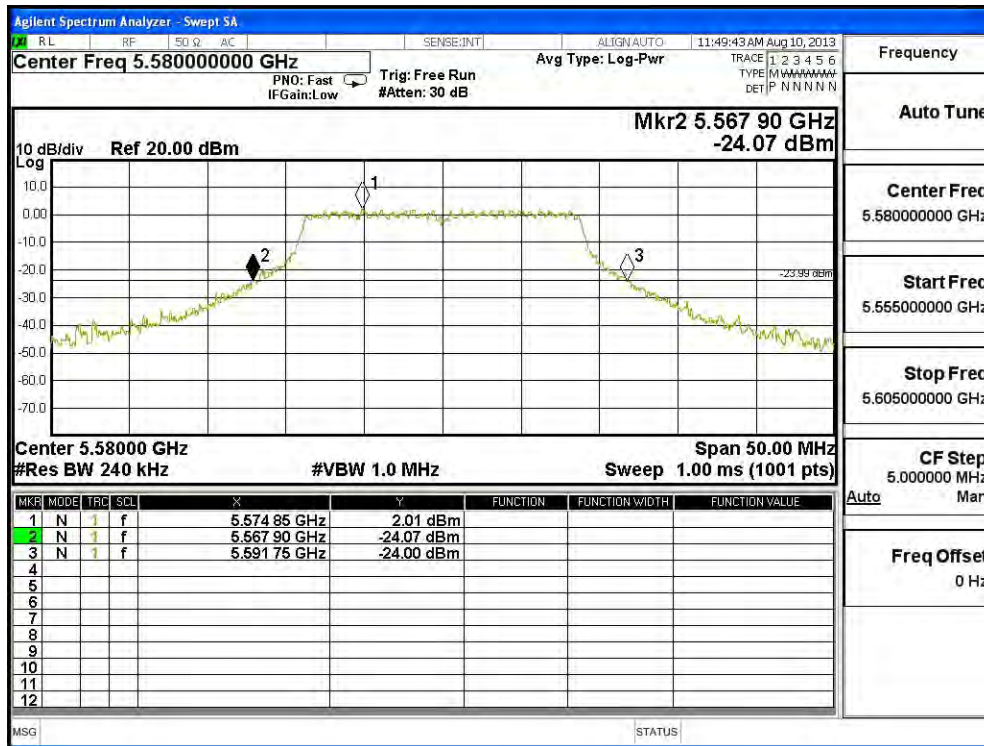

### Channel 140 -Chain B

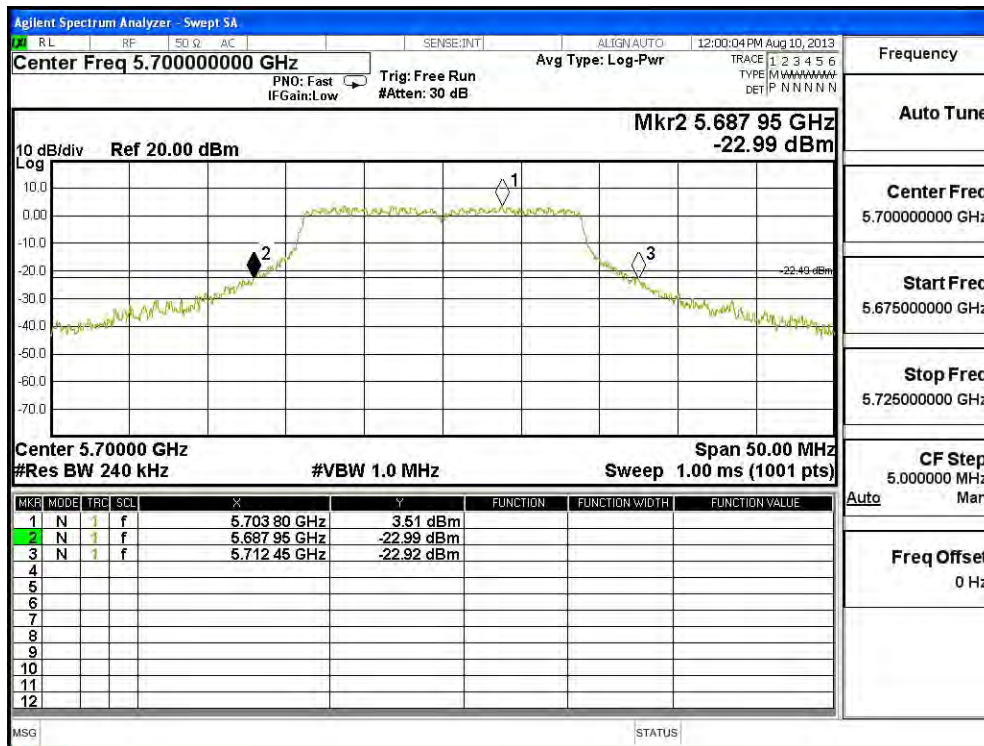



**26dBc Occupied Bandwidth:  
Channel 52 -Chain C**

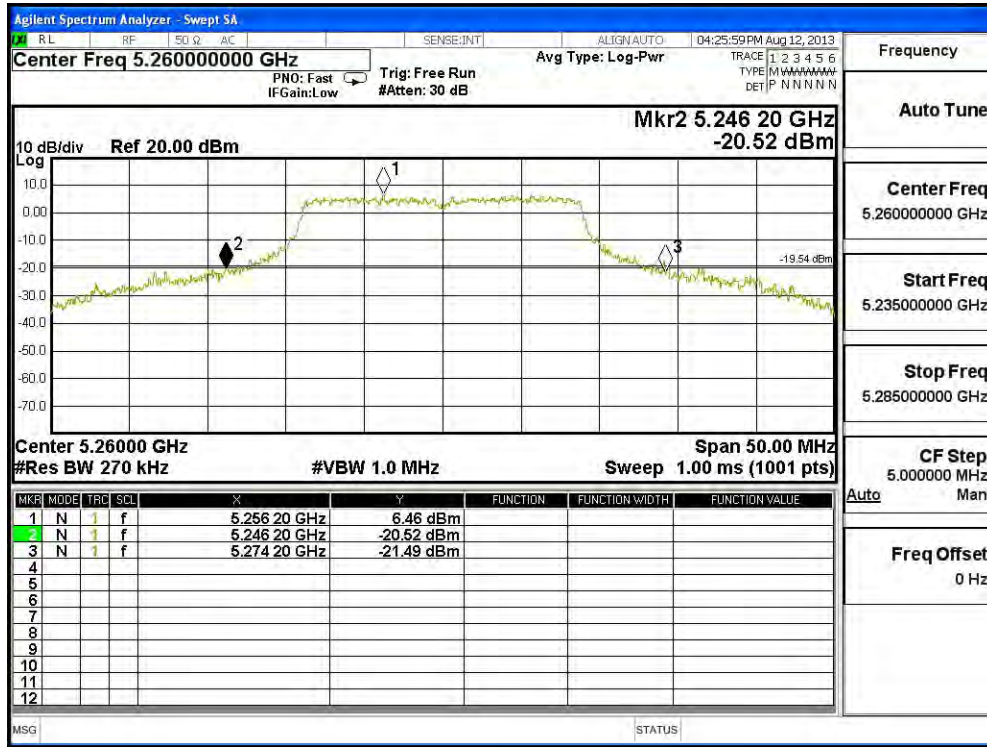

**Channel 60 -Chain C**

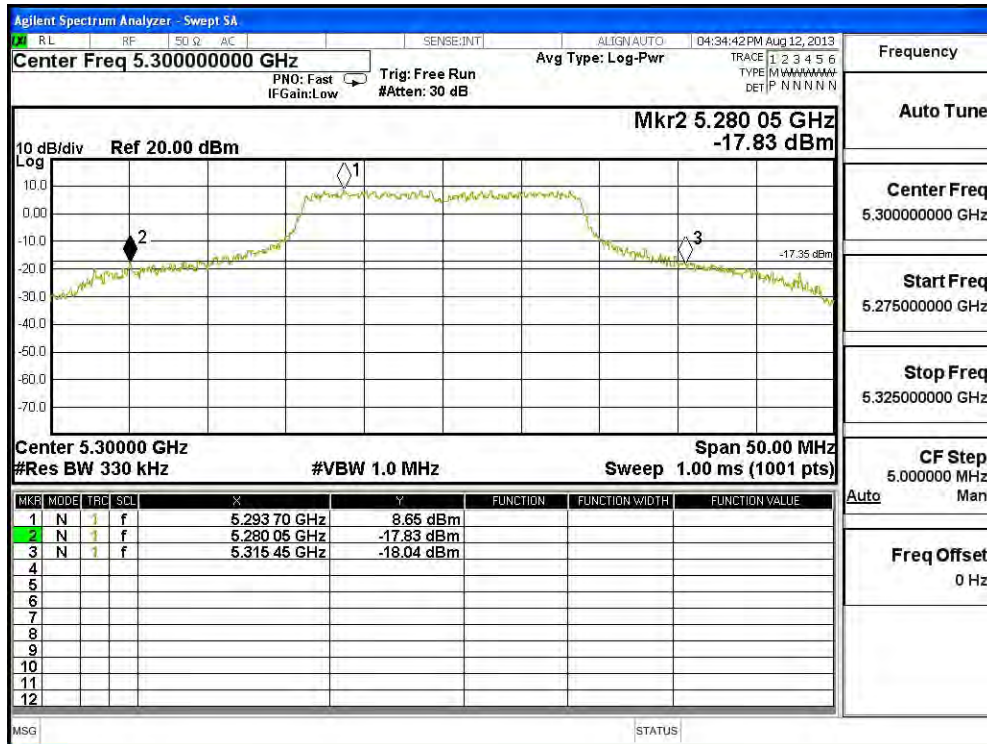

Channel 64 -Chain C

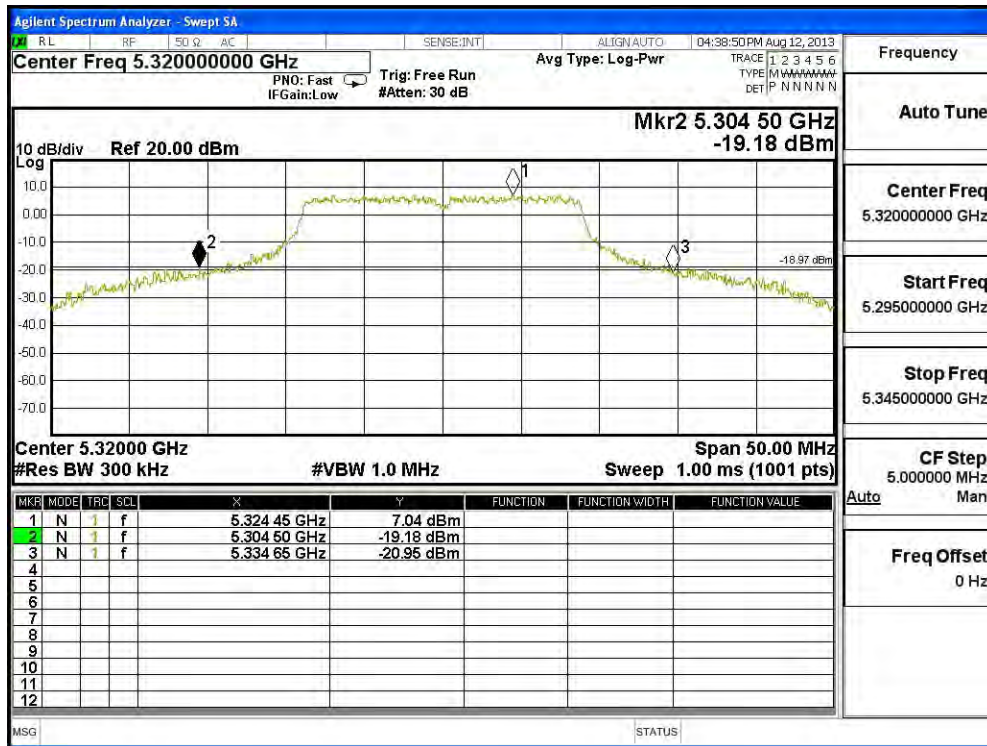

Channel 100 -Chain C

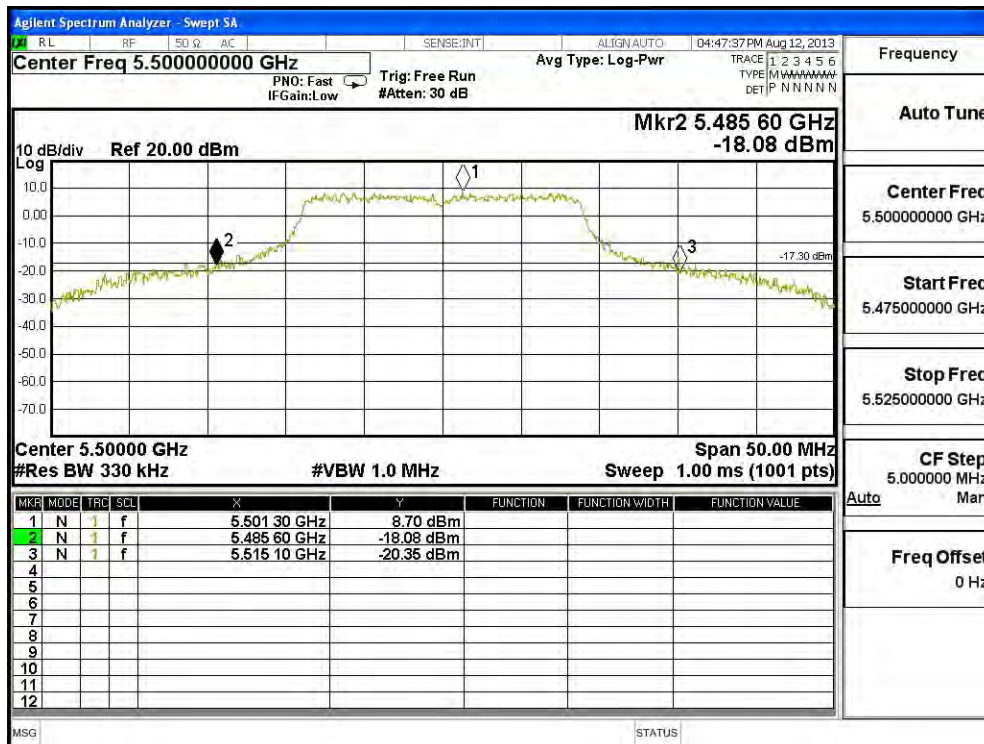

### Channel 120 -Chain C

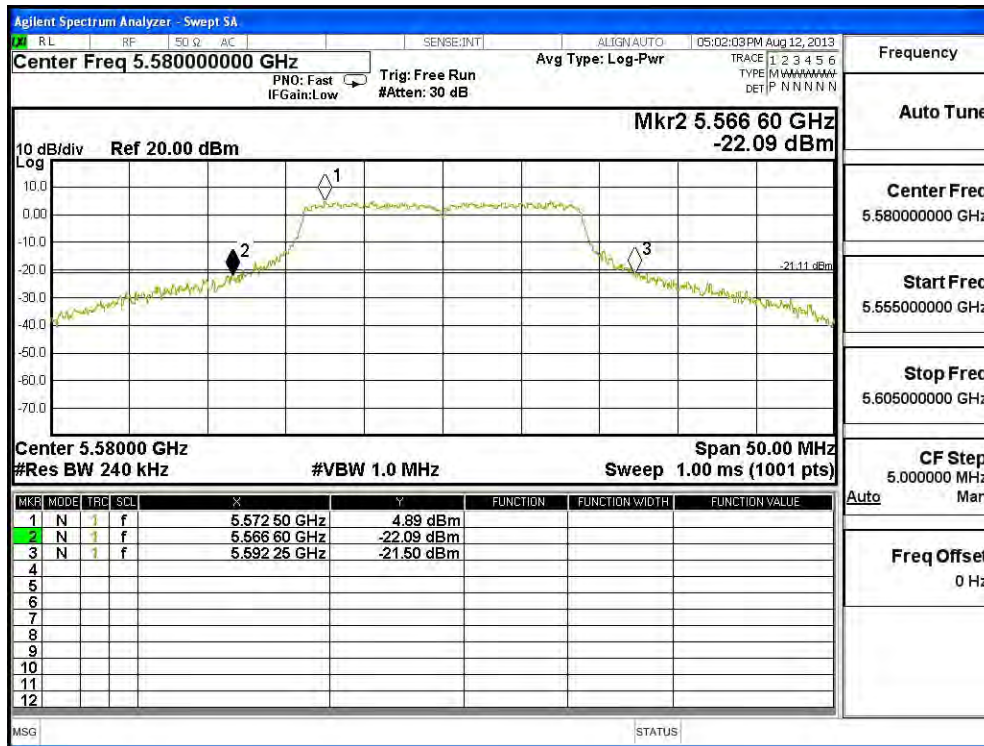

### Channel 140 -Chain C

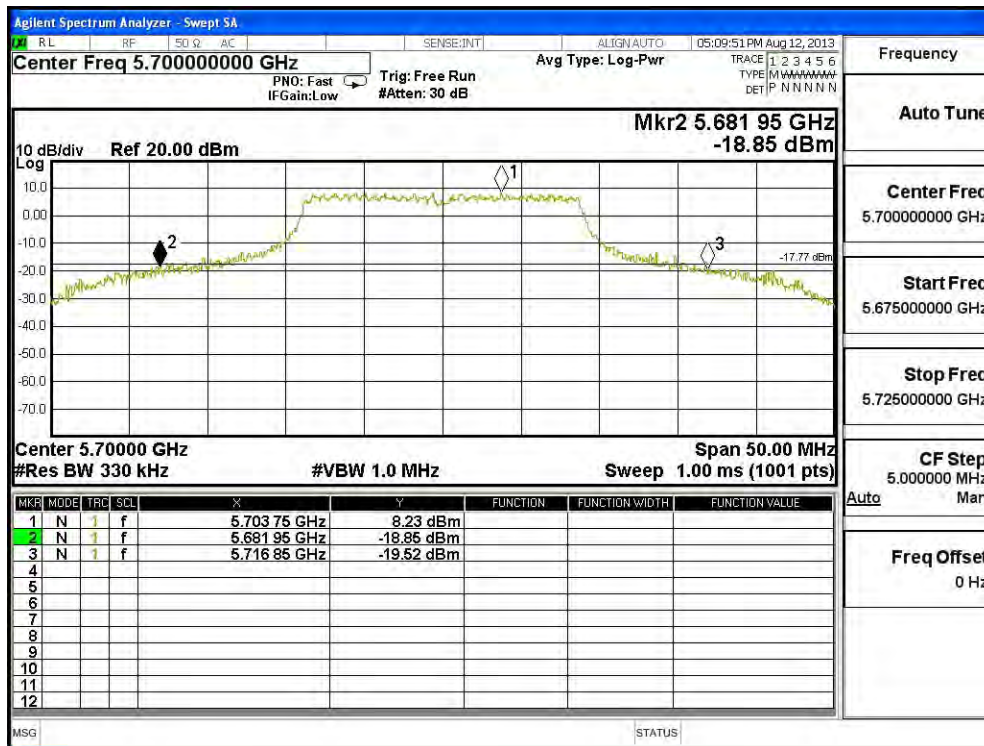

Product : SpectraGuard® Access Point / Sensor  
 Test Item : Maximum conducted output power  
 Test Site : No.3 OATS  
 Test Mode : Mode 6 Transmit (802.11n-40BW 45Mbps)(PIFA Antenna)

**CHAIN A**

Cable loss=1dB		Maximum conducted output power								
Channel No.	Frequency (MHz)	Data Rate (Mbps)								Required Limit
		45	90	135	180	270	360	405	450	
		Measurement Level (dBm)								
54	5270	17.77	--	--	--	--	--	--	--	<24dBm
62	5310	14.37	14.2	14.01	13.83	13.65	13.47	13.29	13.11	<24dBm
102	5510	14.22	--	--	--	--	--	--	--	<24dBm
110	5550	17.80	17.6	17.49	17.32	17.17	17.01	16.86	16.70	<24dBm
134	5670	17.92	--	--	--	--	--	--	--	<24dBm

Note: 1.Maximum conducted output power Value =Reading value on average power meter + cable loss

**CHAIN B**

Cable loss=1dB		Maximum conducted output power								
Channel No.	Frequency (MHz)	Data Rate (Mbps)								Required Limit
		45	90	135	180	270	360	405	450	
		Measurement Level (dBm)								
54	5270	16.56	--	--	--	--	--	--	--	<24dBm
62	5310	12.39	12.25	12.11	11.97	11.83	11.69	11.55	11.41	<24dBm
102	5510	12.71	--	--	--	--	--	--	--	<24dBm
110	5550	16.40	16.27	16.05	15.89	15.72	15.54	15.37	15.19	<24dBm
134	5670	16.03	--	--	--	--	--	--	--	<24dBm

Note: 1.Maximum conducted output power Value =Reading value on average power meter + cable loss

**CHAIN C**

Cable loss=1dB		Maximum conducted output power								
Channel No.	Frequency (MHz)	Data Rate (Mbps)								Required Limit
		45	90	135	180	270	360	405	450	
		Measurement Level (dBm)								
54	5270	17.76	--	--	--	--	--	--	--	<24dBm
62	5310	13.65	13.42	13.29	13.09	12.91	12.73	12.55	12.37	<24dBm
102	5510	14.5	--	--	--	--	--	--	--	<24dBm
110	5550	17.43	17.31	17.16	17.03	16.90	16.76	16.63	16.49	<24dBm
134	5670	17.6	--	--	--	--	--	--	--	<24dBm

Note: 1. Maximum conducted output power Value = Reading value on average power meter + cable loss

**Maximum conducted output power Measurement:**
**(CHAIN A+ B+C)**

Channel Number	Frequency (MHz)	26dB Bandwidth (MHz)	Chain A Power (dBm)	Chain B Power (dBm)	Chain C Power (dBm)	Output Power (dBm)	Output Power Limit	
							(dBm)	dBm+10log(BW)
54	5270	47.500	17.77	16.56	17.76	22.17	24	27.77
62	5310	47.400	14.37	12.39	13.65	18.32	24	27.76
102	5510	47.700	14.22	12.71	14.50	18.65	24	27.79
110	5550	47.000	17.80	16.40	17.43	22.02	24	27.72
134	5670	46.500	17.92	16.03	17.60	22.03	24	27.67

Note:

1. Power Output Value = Reading value on average power meter + cable loss
2. Output Power (dBm) = 10LOG (Chain A Power (mW)+ Chain B Power (mW))
3. 26 dB Bandwidth is the bandwidth of chain A or chain B whichever is less bandwidth, output power

**26dBc Occupied Bandwidth:  
Channel 54 – Chain A**

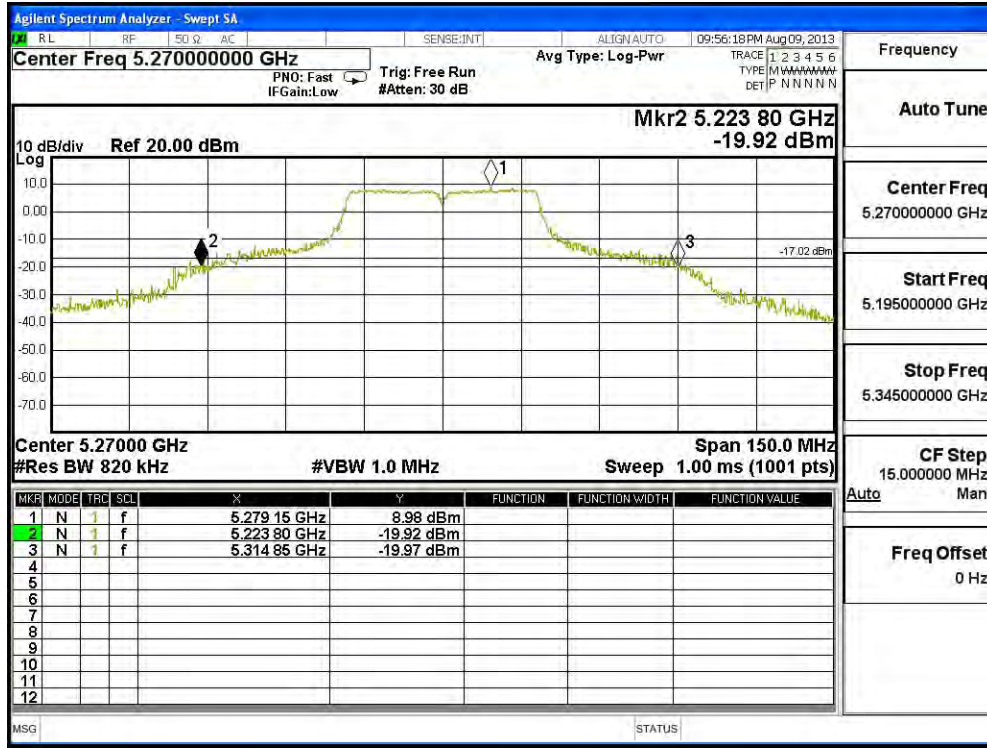

**Channel 62 – Chain A**

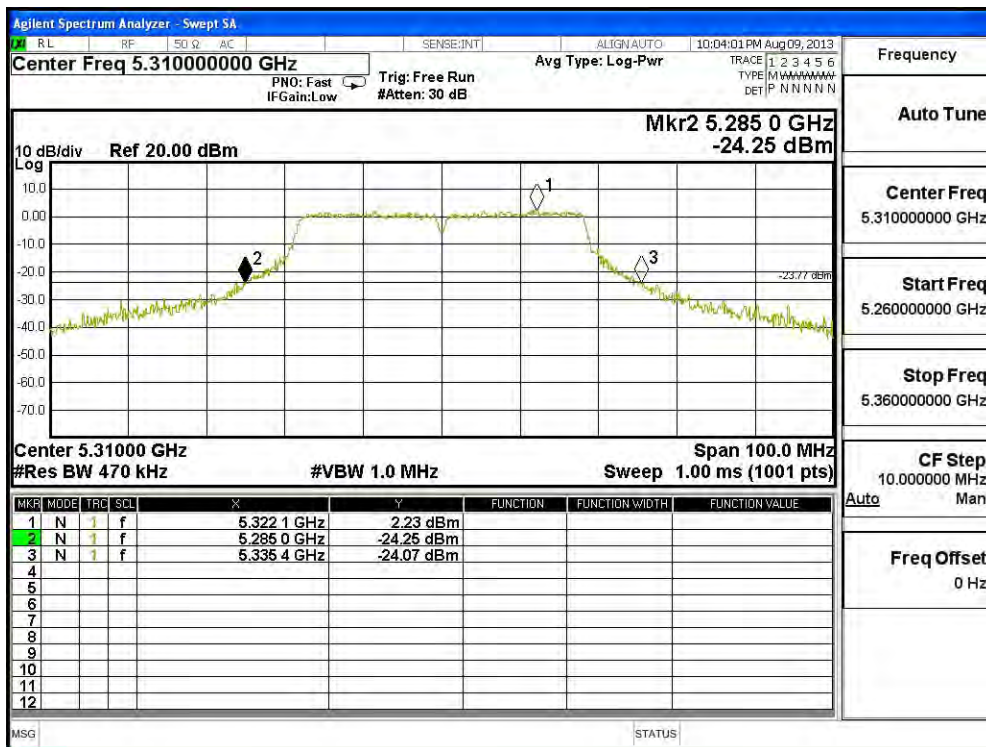

**Channel 102 – Chain A**

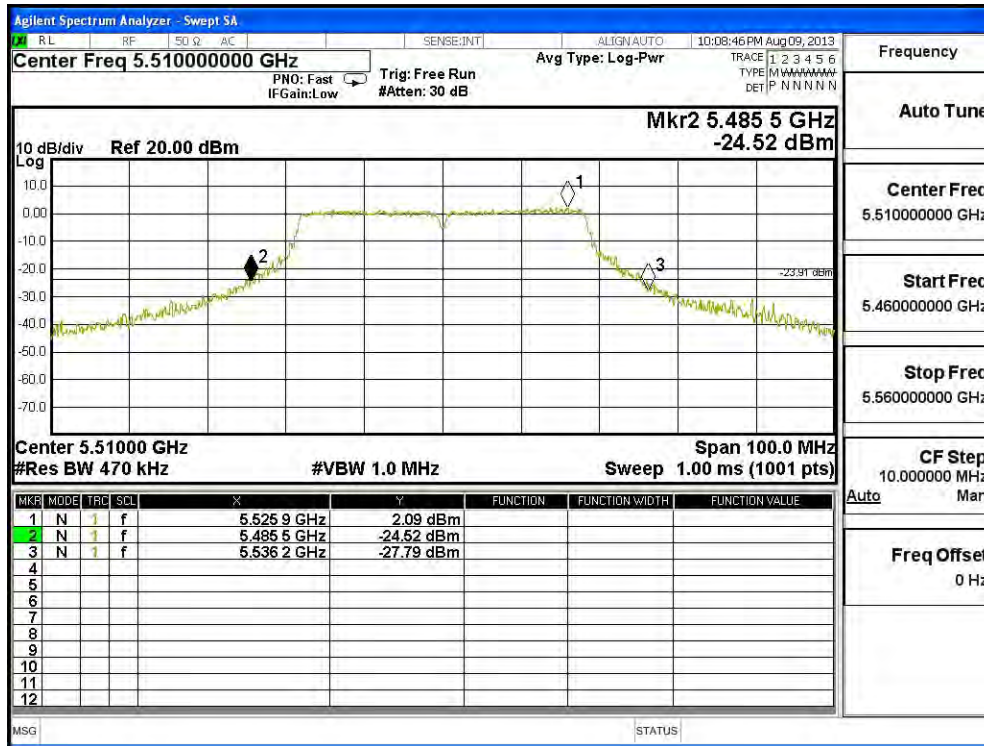

**Channel 110 – Chain A**

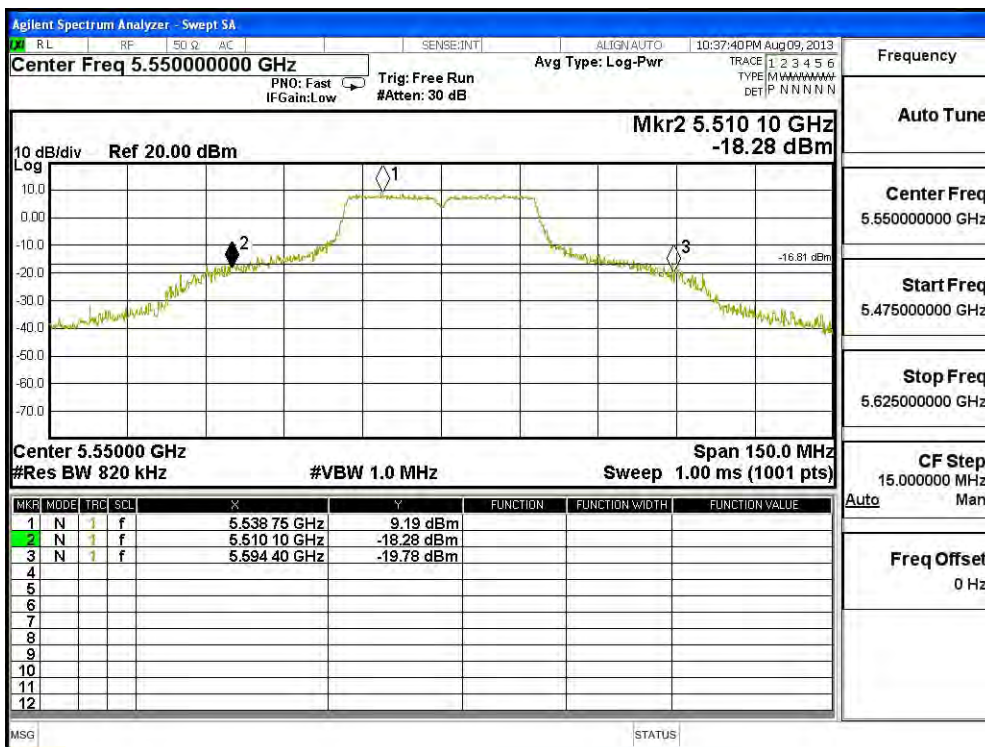

Channel 134 – Chain A

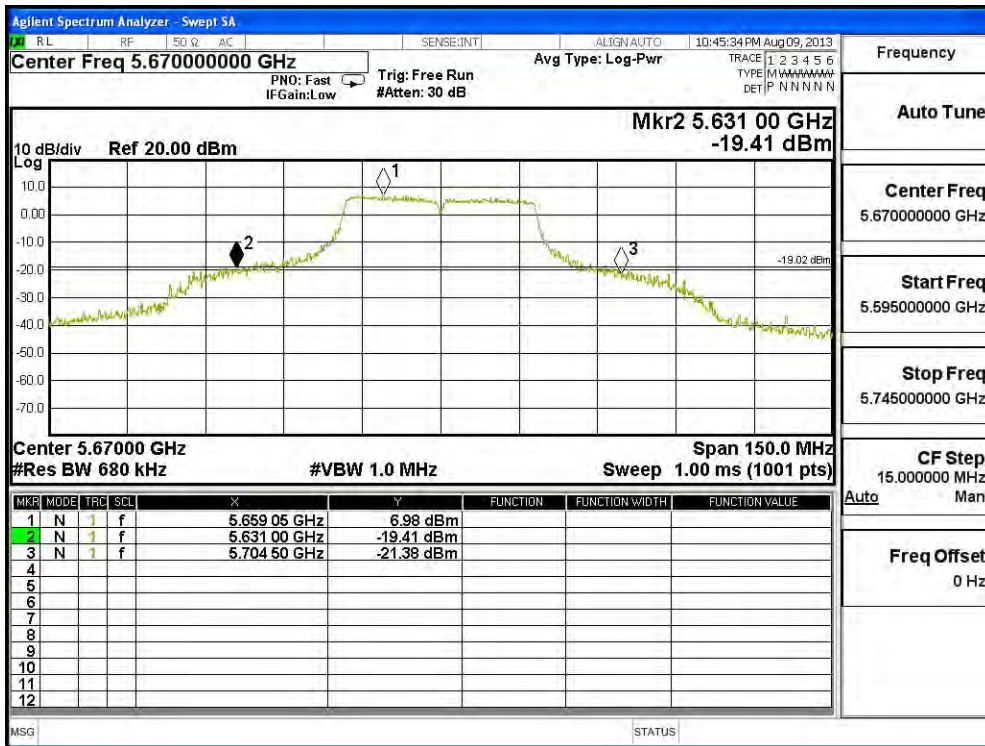



**26dBc Occupied Bandwidth:  
Channel 54 – Chain B**

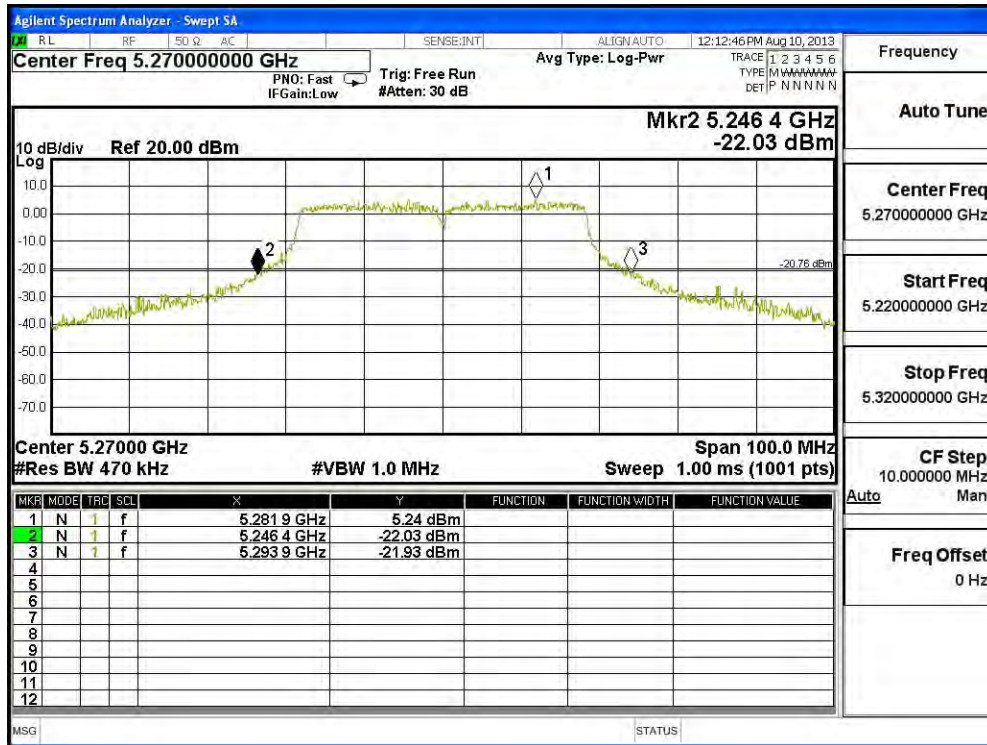

**Channel 62 – Chain B**

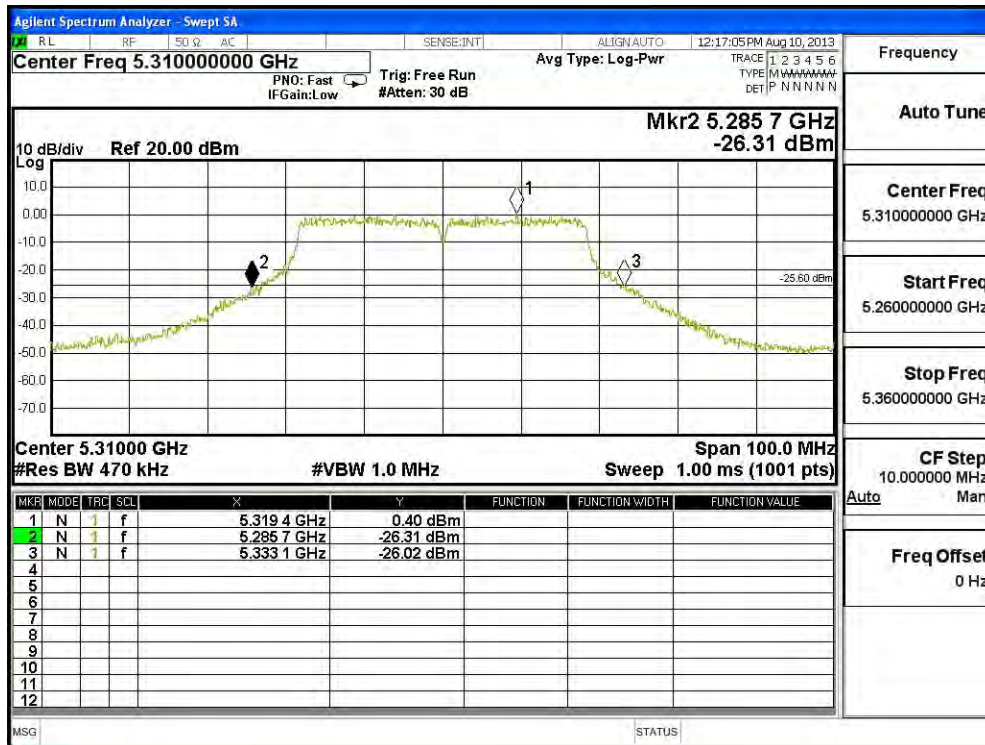

**Channel 102 – Chain B**

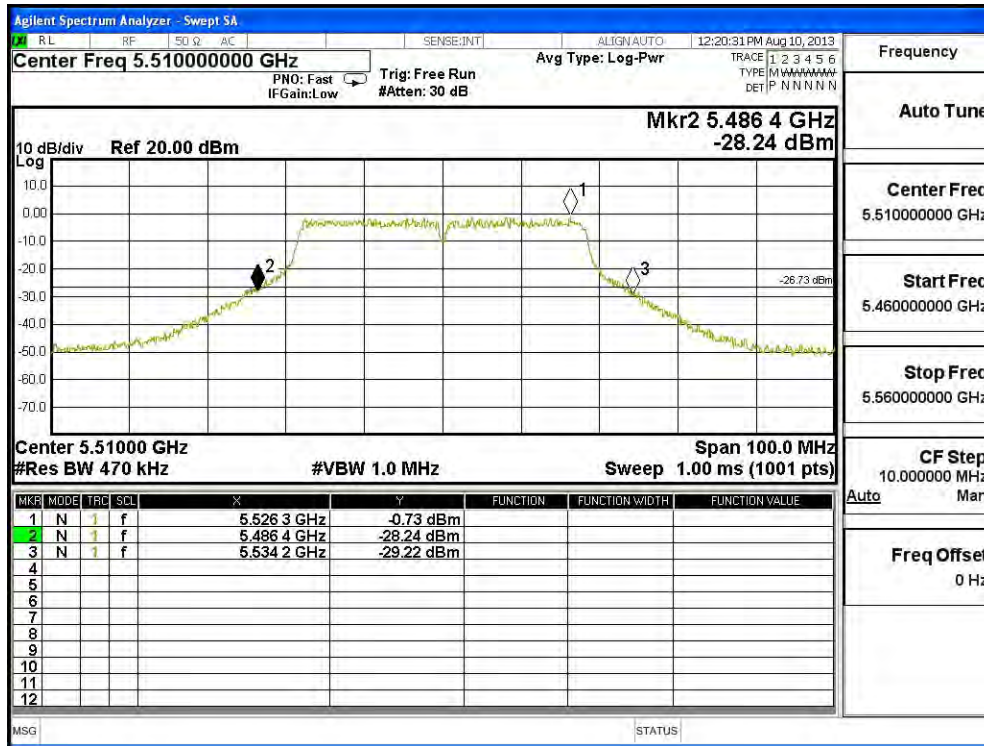

**Channel 110 – Chain B**

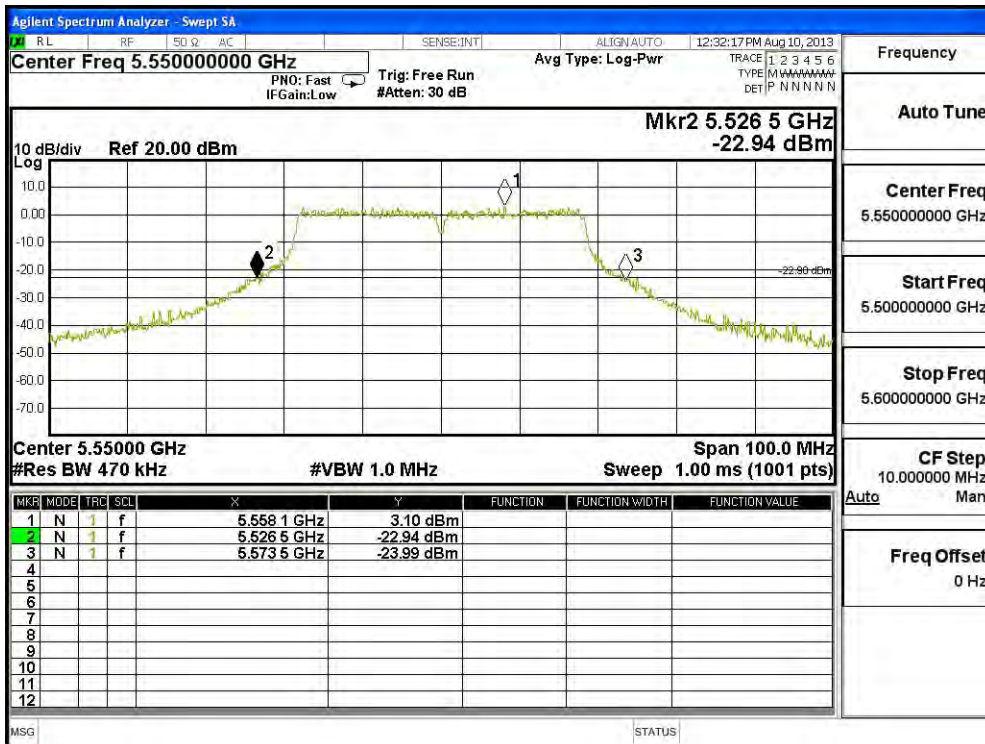

Channel 134 – Chain B

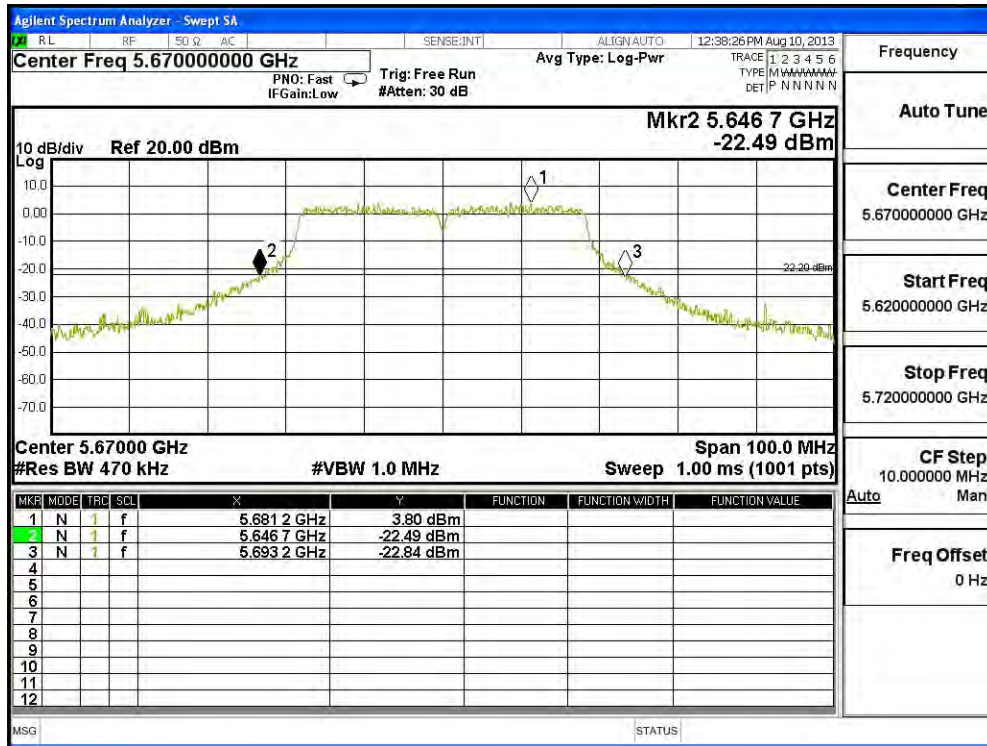

### 26dBc Occupied Bandwidth: Channel 54 – Chain C

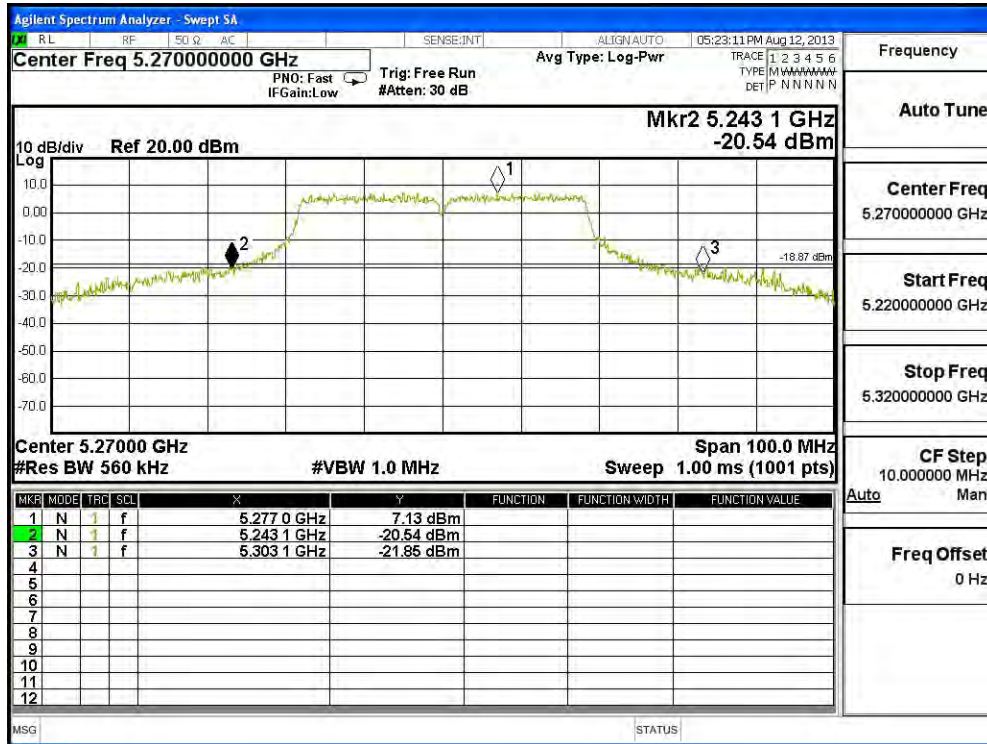

### Channel 62 – Chain C

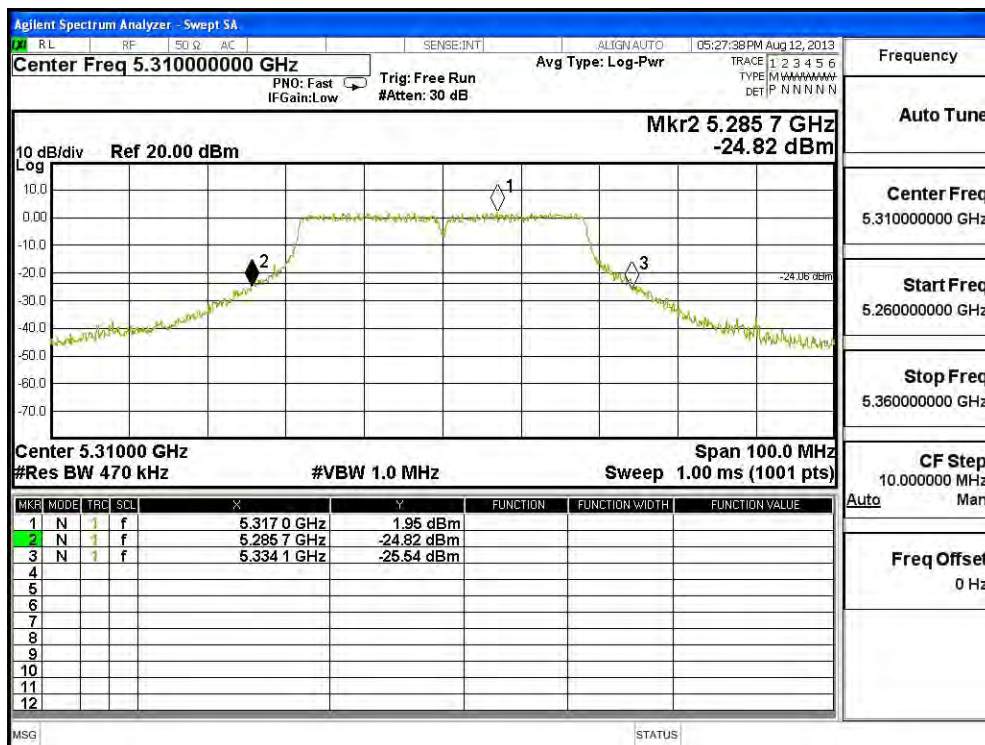

### Channel 102 – Chain C

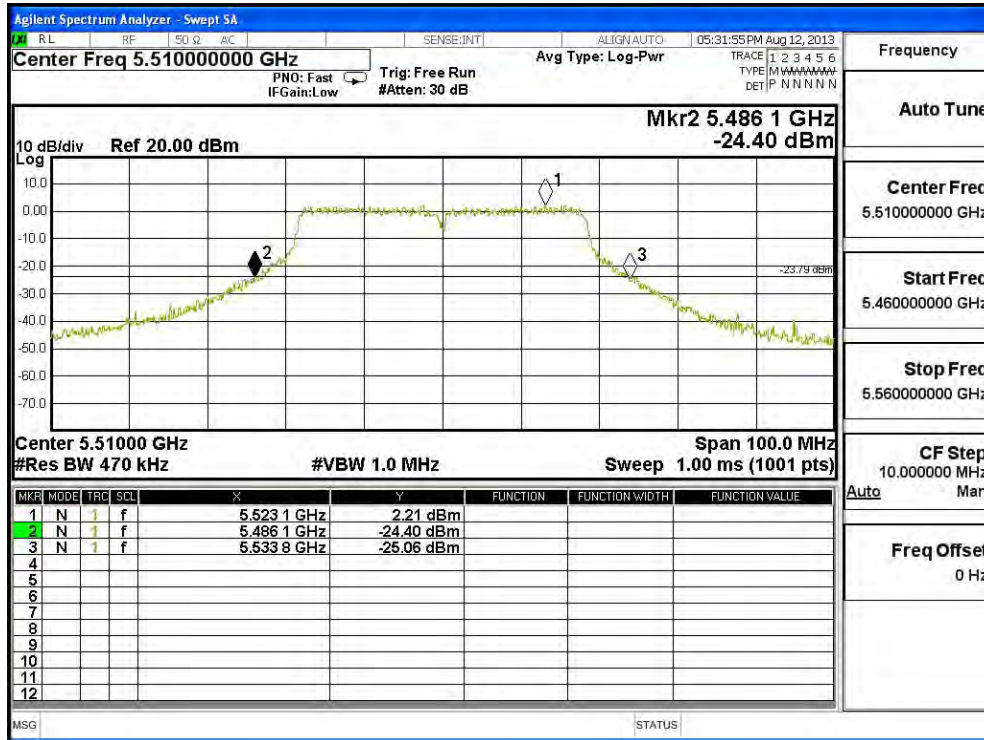

### Channel 110 – Chain C

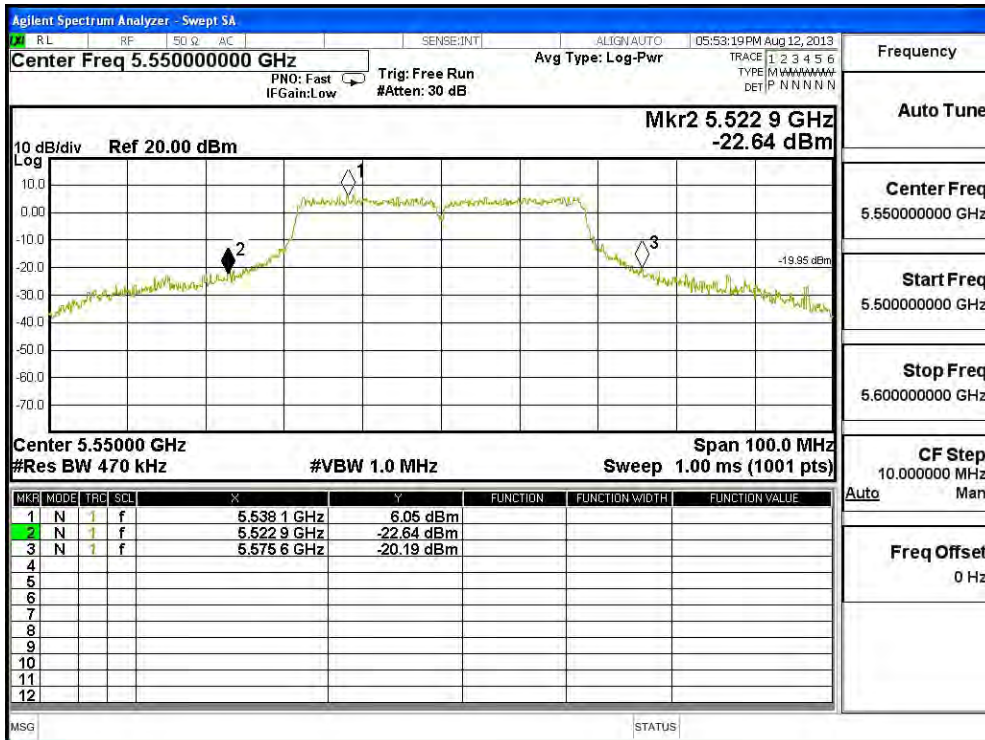

Channel 134 – Chain C

