

FCC Test Report (Class II Permissive Change)

Product Name	SpectraGuard® Access Point / Sensor
Model No	SS-300AT-C-60
FCC ID	TOR-SS300ATC60

Applicant	AirTight Networks, Inc.
Address	339 N. Bernardo Avenue, Suite #200, Mountain View, California, USA

Date of Receipt	July 03, 2013
Issued Date	Nov. 12, 2013
Report No.	137146R-RFUSP05V00-A
Report Version	V1.0



The test results relate only to the samples tested.

The test report shall not be reproduced except in full without the written approval of Quietek Corporation.
This report must not be used to claim product endorsement by TAF or any agency of the U.S. Government

Test Report Certification

Issued Date: Nov. 12, 2013

Report No.: 137146R-RFUSP05V00-A



Product Name	SpectraGuard® Access Point / Sensor
Applicant	AirTight Networks, Inc.
Address	339 N. Bernardo Avenue, Suite #200, Mountain View, California, USA
Manufacturer	DONG GUAN G-COM COMPUTER CO., LTD.
Model No.	SS-300AT-C-60
FCC ID.	TOR-SS300ATC60
EUT Rated Voltage	DC 12V
EUT Test Voltage	AC 120V/60Hz
Trade Name	AirTight
Applicable Standard	FCC CFR Title 47 Part 15 Subpart E: 2012 ANSI C63.4: 2003, ANSI C63.10: 2009, FCC KDB-789033
Test Result	Complied

The test results relate only to the samples tested.

The test report shall not be reproduced except in full without the written approval of Quietek Corporation.

This report must not be used to claim product endorsement by TAF or any agency of the U.S. Government

Documented By : Leven Huang
(Senior Adm. Specialist / Leven Huang)

Tested By : Jack Hsu
(Engineer / Jack Hsu)

Approved By : [Signature]
(Manager / Vincent Lin)

TABLE OF CONTENTS

Description	Page
1. GENERAL INFORMATION	5
1.1. EUT Description	5
1.2. Operational Description	7
1.3. Tested System Details	8
1.4. Configuration of tested System	8
1.5. EUT Exercise Software	8
1.6. Test Facility	9
2. Conducted Emission	10
2.1. Test Equipment	10
2.2. Test Setup	10
2.3. Limits	11
2.4. Test Procedure	11
2.5. Uncertainty	11
2.6. Test Result of Conducted Emission	12
3. Maximum conducted output power	20
3.1. Test Equipment	20
3.2. Test Setup	20
3.3. Limits	21
3.4. Test Procedure	21
3.5. Uncertainty	21
3.6. Test Result of Maximum conducted output power	22
4. Peak Power Spectral Density	70
4.1. Test Equipment	70
4.2. Test Setup	70
4.3. Limits	70
4.4. Test Procedure	71
4.5. Uncertainty	71
4.6. Test Result of Peak Power Spectral Density	72
5. Peak Excursion	113
5.1. Test Equipment	113
5.2. Test Setup	113
5.3. Limits	113
5.4. Test Procedure	114
5.5. Uncertainty	114
5.6. Test Result of Peak Excursion	115
6. Radiated Emission	151
6.1. Test Equipment	151
6.2. Test Setup	151
6.3. Limits	152
6.4. Test Procedure	153
6.5. Uncertainty	153
6.6. Test Result of Radiated Emission	154

7.	Band Edge	200
7.1.	Test Equipment.....	200
7.2.	Test Setup	201
7.3.	Limits	202
7.4.	Test Procedure	202
7.5.	Uncertainty	202
7.6.	Test Result of Band Edge	203
8.	Frequency Stability.....	251
8.1.	Test Equipment.....	251
8.2.	Test Setup	251
8.3.	Limits	251
8.4.	Test Procedure	251
8.5.	Uncertainty	251
8.6.	Test Result of Frequency Stability.....	252
9.	EMI Reduction Method During Compliance Testing	260

Attachment 1: EUT Test Photographs

Attachment 2: EUT Detailed Photographs

1. GENERAL INFORMATION

1.1. EUT Description

Product Name	SpectraGuard® Access Point / Sensor
Trade Name	AirTight
FCC ID.	TOR-SS300ATC60
Model No.	SS-300AT-C-60
Frequency Range	802.11a/n-20MHz: 5260-5320MHz, 5500-5700MHz 802.11n-40MHz: 5270-5310MHz, 5510-5670MHz
Number of Channels	802.11a/n-20MHz: 12, n-40MHz: 5
Data Rate	802.11a/g: 6-54Mbps, 802.11n: up to 300Mbps
Channel Control	Auto
Type of Modulation	802.11a/n:OFDM, BPSK, QPSK, 16QAM, 64QAM
Antenna type	PIFA / Dipole
Antenna Gain	Refer to the table “Antenna List”

Antenna List

No.	Manufacturer	Part No.	Peak Gain	Note
1	JOYMAX	JWX-614XRSXX-361	5dBi For 5.25~5.35GHz	External Antenna (Dipole)
		JWX-614XRSXX-361	5dBi For 5.47~5.725GHz	
2	MAG.LAYERS	MSA-3810-2G4C1-A36	2.64dBi For 5.25~5.35GHz	Internal Antenna (PIFA)
		MSA-3810-2G4C1-A38	1.38dBi For 5.47~5.725GHz	

Note: The antenna of EUT is conform to FCC 15.203

802.11a/n-20MHz Center Working Frequency of Each Channel:

Channel	Frequency	Channel	Frequency	Channel	Frequency	Channel	Frequency
Channel 52:	5260 MHz	Channel 56:	5280 MHz	Channel 60:	5300 MHz	Channel 64:	5320 MHz
Channel 100:	5500 MHz	Channel 104:	5520 MHz	Channel 108:	5540 MHz	Channel 112:	5560 MHz
Channel 116:	5580 MHz	Channel 132:	5660 MHz	Channel 136:	5680 MHz	Channel 140:	5700 MHz

802.11n-40MHz Center Working Frequency of Each Channel:

Channel	Frequency	Channel	Frequency	Channel	Frequency	Channel	Frequency
Channel 54:	5270 MHz	Channel 62:	5310 MHz	Channel 102:	5510 MHz	Channel 110:	5550 MHz
Channel 134:	5670 MHz						

Note:

1. This device is a SpectraGuard® Access Point / Sensor with a built-in two WLAN module, module 1 support 2T2R, module 2 support 3T3R technology, this report for 2T2R module.
2. Regarding to the operation frequency, the lowest, middle and highest frequency are selected to perform the test.
3. This is requesting a Class II permissive change for FCC ID: TOR-SS300ATC60. Originally granted on 09/18/2013.
The differences are listed as below:
 - Add the frequency band from 5250-5350MHz and 5470 – 5725MHz by software.
 - All other hardware is identical with original granted.
4. Lowest and highest data rates are tested in each mode. Only worst case is shown in the report. (802.11a is 6Mbps, 802.11n-20BW is 14.4Mbps and 802.11n-40BW are 30Mbps)
5. These tests were conducted on a sample of the equipment for the purpose of demonstrating compliance with Part 15 Subpart E for Unlicensed National Information Infrastructure devices.
6. The radiation measurements are performed in X, Y, Z axis positioning. Only the worst case is shown in the report.

Test Mode	Mode 1: Transmit (802.11a-6Mbps)(Dipole Antenna)
	Mode 2: Transmit (802.11n-20BW 14.4Mbps)(Dipole Antenna)
	Mode 3: Transmit (802.11n-40BW 30Mbps)(Dipole Antenna)
	Mode 4: Transmit (802.11a-6Mbps)(PIFA Antenna)
	Mode 5: Transmit (802.11n-20BW 14.4Mbps)(PIFA Antenna)
	Mode 6: Transmit (802.11n-40BW 30Mbps)(PIFA Antenna)

1.3. Tested System Details

The types for all equipment, plus descriptions of all cables used in the tested system (including inserted cards) are:

Product	Manufacturer	Model No.	Serial No.	Power Cord
(1) Notebook PC	DELL	PPT	N/A	Non-Shielded, 0.8m
(2) Power Adapter	DVE	DSA-15P-12 US 120150	N/A	Non-Shielded, 1.7m

Signal Cable Type	Signal cable Description
A RJ45 Cable	Non-Shielded, 5.0m
B RJ45 to RS-232 Cable	Non-Shielded, 5.0m
C RJ45 Cable	Non-Shielded, 5.0m
D Power Cable	Non-Shielded, 1.7m

1.4. Configuration of tested System

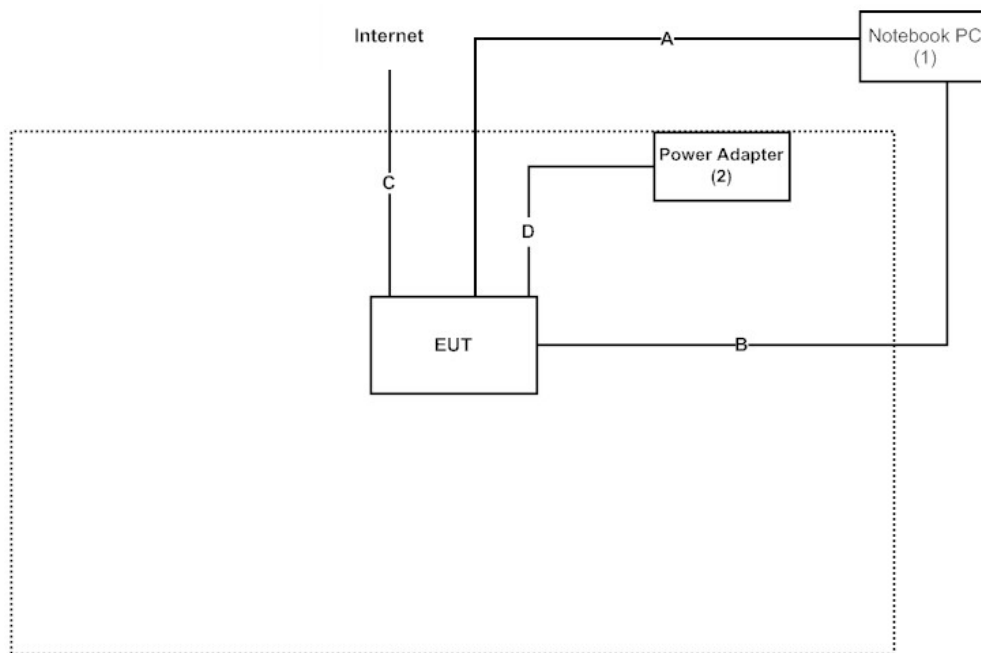

1.5. EUT Exercise Software

- (1) Connect EUT and Notebook via LAN Cable
- (2) Execute "Art2. V2.3 exe" program on the Notebook
- (3) Configure the test mode, the test channel, and the data rate.
- (4) Start the continuous transmission.
- (5) Remove Notebook, Setup the EUT as shown in Section 1.4

1.6. Test Facility

Ambient conditions in the laboratory:

Items	Required (IEC 68-1)	Actual
Temperature (°C)	15-35	20-35
Humidity (%RH)	25-75	50-65
Barometric pressure (mbar)	860-1060	950-1000

The related certificate for our laboratories about the test site and management system can be downloaded from Quietek Corporation's Web Site : <http://tw.quietek.com/modules/myalbum/>

The address and introduction of Quietek Corporation's laboratories can be founded in our Web site : <http://www.quietek.com/>

Site Description: File on
Federal Communications Commission
FCC Engineering Laboratory
7435 Oakland Mills Road
Columbia, MD 21046
Registration Number: 92195

Site Name: Quietek Corporation
Site Address: No. 5-22, Ruei-Shu Valley, Ruei-Ping Tsuen,
Lin-Kou Shiang, Taipei,
Taiwan, R.O.C.
TEL: 886-2-8601-3788 / FAX : 886-2-8601-3789
E-Mail : service@quietek.com

FCC Accreditation Number: TW1014

2. Conducted Emission

2.1. Test Equipment

	Equipment	Manufacturer	Model No. / Serial No.	Last Cal.	Remark
X	Test Receiver	R & S	ESCS 30 / 825442/018	Sep., 2012	
X	Artificial Mains Network	R & S	ENV4200 / 848411/10	Feb., 2013	Peripherals
X	LISN	R & S	ESH3-Z5 / 825562/002	Feb., 2013	EUT
	DC LISN	Schwarzbeck	8226 / 176	Mar, 2013	EUT
X	Pulse Limiter	R & S	ESH3-Z2 / 357.8810.52	Feb., 2013	
	No.1 Shielded Room				

Note:

1. All equipments are calibrated every one year.
2. The test instruments marked by “X” are used to measure the final test results.

2.2. Test Setup

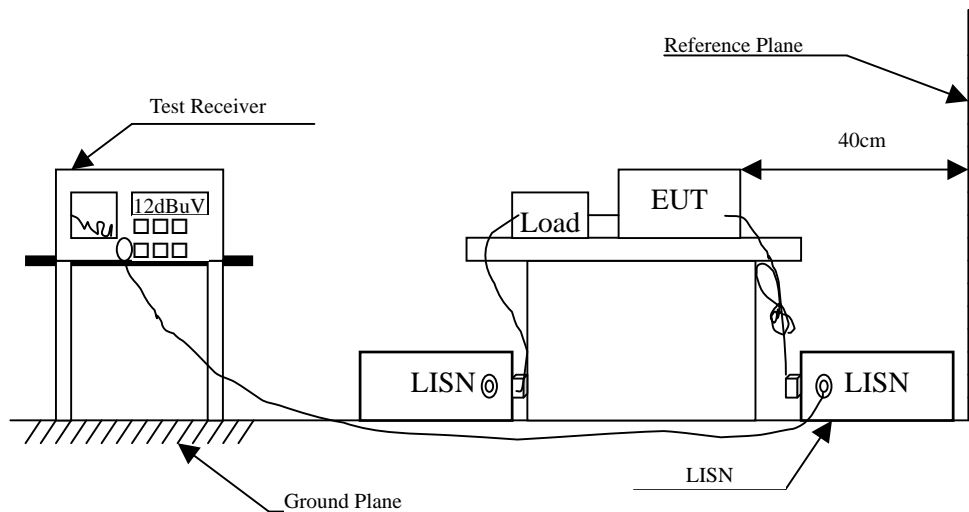

2.3. Limits

FCC Part 15 Subpart C Paragraph 15.207 (dBuV) Limit		
Frequency MHz	Limits	
	QP	AV
0.15 - 0.50	66-56	56-46
0.50-5.0	56	46
5.0 - 30	60	50

Remarks : In the above table, the tighter limit applies at the band edges.

2.4. Test Procedure

The EUT and simulators are connected to the main power through a line impedance stabilization network (L.I.S.N.). This provides a 50 ohm /50uH coupling impedance for the measuring equipment. The peripheral devices are also connected to the main power through a LISN that provides a 50ohm /50uH coupling impedance with 50ohm termination. (Please refers to the block diagram of the test setup and photographs.)

Both sides of A.C. line are checked for maximum conducted interference. In order to find the maximum emission, the relative positions of equipment and all of the interface cables must be changed according to ANSI C63.10:2009 on conducted measurement.

Conducted emissions were invested over the frequency range from 0.15MHz to 30MHz using a receiver bandwidth of 9kHz.

The EUT was setup to ANSI C63.10, 2009; tested to DTS test procedure of FCC KDB-789033 for compliance to FCC 47CFR Subpart E requirements.

2.5. Uncertainty

± 2.26 dB

2.6. Test Result of Conducted Emission

Product : SpectraGuard® Access Point / Sensor
 Test Item : Conducted Emission Test
 Power Line : Line 1
 Test Mode : Mode 3: Transmit (802.11n-40BW 30Mbps)(Dipole Antenna) (5270MHz)

Frequency MHz	Correct Factor dB	Reading Level dBuV	Measurement Level dBuV	Margin dB	Limit dBuV
LINE 1					
Quasi-Peak					
0.158	9.951	39.060	49.011	-16.760	65.771
0.205	9.910	31.820	41.730	-22.699	64.429
0.310	9.870	25.160	35.030	-26.399	61.429
0.588	9.817	20.810	30.627	-25.373	56.000
0.857	9.770	21.190	30.960	-25.040	56.000
11.271	10.220	33.450	43.670	-16.330	60.000
Average					
0.158	9.951	9.540	19.491	-36.280	55.771
0.205	9.910	11.630	21.540	-32.889	54.429
0.310	9.870	19.520	29.390	-22.039	51.429
0.588	9.817	11.690	21.507	-24.493	46.000
0.857	9.770	11.560	21.330	-24.670	46.000
11.271	10.220	26.340	36.560	-13.440	50.000

Note:

1. All Reading Levels are Quasi-Peak and average value.
2. "■" means the worst emission level.
3. Measurement Level = Reading Level + Correct Factor

Product : SpectraGuard® Access Point / Sensor
 Test Item : Conducted Emission Test
 Power Line : Line 2
 Test Mode : Mode 3: Transmit (802.11n-40BW 30Mbps)(Dipole Antenna) (5270MHz)

Frequency MHz	Correct Factor dB	Reading Level dBuV	Measurement Level dBuV	Margin dB	Limit dBuV
LINE 2					
Quasi-Peak					
0.216	9.752	31.920	41.672	-22.442	64.114
0.306	9.750	23.630	33.380	-28.163	61.543
0.580	9.760	15.080	24.840	-31.160	56.000
0.806	9.766	13.040	22.806	-33.194	56.000
1.103	9.790	12.860	22.650	-33.350	56.000
11.326	10.080	27.640	37.720	-22.280	60.000
Average					
0.216	9.752	3.580	13.332	-40.782	54.114
0.306	9.750	10.470	20.220	-31.323	51.543
0.580	9.760	3.640	13.400	-32.600	46.000
0.806	9.766	1.620	11.386	-34.614	46.000
1.103	9.790	3.010	12.800	-33.200	46.000
11.326	10.080	18.870	28.950	-21.050	50.000

Note:

1. All Reading Levels are Quasi-Peak and average value.
2. "■" means the worst emission level.
3. Measurement Level = Reading Level + Correct Factor

Product : SpectraGuard® Access Point / Sensor
 Test Item : Conducted Emission Test
 Power Line : Line 1
 Test Mode : Mode 3: Transmit (802.11n-40BW 30Mbps)(Dipole Antenna) (5550MHz)

Frequency MHz	Correct Factor dB	Reading Level dBuV	Measurement Level dBuV	Margin dB	Limit dBuV
LINE 1					
Quasi-Peak					
0.166	9.943	37.720	47.663	-17.880	65.543
0.212	9.904	32.470	42.374	-21.855	64.229
0.302	9.872	24.690	34.562	-27.095	61.657
0.404	9.868	17.250	27.118	-31.625	58.743
0.580	9.820	20.020	29.840	-26.160	56.000
11.080	10.201	33.360	43.561	-16.439	60.000
Average					
0.166	9.943	12.280	22.223	-33.320	55.543
0.212	9.904	8.120	18.024	-36.205	54.229
0.302	9.872	14.970	24.842	-26.815	51.657
0.404	9.868	4.600	14.468	-34.275	48.743
0.580	9.820	9.930	19.750	-26.250	46.000
11.080	10.201	26.210	36.411	-13.589	50.000

Note:

1. All Reading Levels are Quasi-Peak and average value.
2. "■" means the worst emission level.
3. Measurement Level = Reading Level + Correct Factor

Product : SpectraGuard® Access Point / Sensor
 Test Item : Conducted Emission Test
 Power Line : Line 2
 Test Mode : Mode 3: Transmit (802.11n-40BW 30Mbps)(Dipole Antenna) (5550MHz)

Frequency MHz	Correct Factor dB	Reading Level dBuV	Measurement Level dBuV	Margin dB	Limit dBuV
LINE 2					
Quasi-Peak					
0.150	9.804	38.440	48.244	-17.756	66.000
0.166	9.801	36.870	46.671	-18.872	65.543
0.357	9.760	15.630	25.390	-34.696	60.086
0.588	9.760	15.660	25.420	-30.580	56.000
1.529	9.800	11.930	21.730	-34.270	56.000
11.716	10.100	27.150	37.250	-22.750	60.000
Average					
0.150	9.804	10.230	20.034	-35.966	56.000
0.166	9.801	10.630	20.431	-35.112	55.543
0.357	9.760	0.740	10.500	-39.586	50.086
0.588	9.760	4.600	14.360	-31.640	46.000
1.529	9.800	1.780	11.580	-34.420	46.000
11.716	10.100	18.320	28.420	-21.580	50.000

Note:

1. All Reading Levels are Quasi-Peak and average value.
2. "■" means the worst emission level.
3. Measurement Level = Reading Level + Correct Factor

Product : SpectraGuard® Access Point / Sensor
 Test Item : Conducted Emission Test
 Power Line : Line 1
 Test Mode : Mode 6: Transmit (802.11n-40BW 30Mbps)(PIFA Antenna) (5270MHz)

Frequency MHz	Correct Factor dB	Reading Level dBuV	Measurement Level dBuV	Margin dB	Limit dBuV
LINE 1					
Quasi-Peak					
0.166	9.943	36.550	46.493	-19.050	65.543
0.216	9.902	31.660	41.562	-22.552	64.114
0.306	9.871	24.770	34.641	-26.902	61.543
0.384	9.865	19.370	29.235	-30.079	59.314
0.576	9.821	19.640	29.461	-26.539	56.000
11.252	10.219	33.530	43.749	-16.251	60.000
Average					
0.166	9.943	12.190	22.133	-33.410	55.543
0.216	9.902	4.940	14.842	-39.272	54.114
0.306	9.871	18.890	28.761	-22.782	51.543
0.384	9.865	8.670	18.535	-30.779	49.314
0.576	9.821	9.410	19.231	-26.769	46.000
11.252	10.219	26.410	36.629	-13.371	50.000

Note:

1. All Reading Levels are Quasi-Peak and average value.
2. "■" means the worst emission level.
3. Measurement Level = Reading Level + Correct Factor

Product : SpectraGuard® Access Point / Sensor
 Test Item : Conducted Emission Test
 Power Line : Line 2
 Test Mode : Mode 6: Transmit (802.11n-40BW 30Mbps)(PIFA Antenna) (5270MHz)

Frequency MHz	Correct Factor dB	Reading Level dBuV	Measurement Level dBuV	Margin dB	Limit dBuV
LINE 2					
Quasi-Peak					
0.209	9.757	35.630	45.387	-18.927	64.314
0.271	9.753	24.600	34.353	-28.190	62.543
0.330	9.757	24.650	34.407	-26.450	60.857
0.470	9.764	13.060	22.824	-34.033	56.857
0.849	9.770	15.570	25.340	-30.660	56.000
11.185	10.080	27.780	37.860	-22.140	60.000
Average					
0.209	9.757	9.530	19.287	-35.027	54.314
0.271	9.753	5.740	15.493	-37.050	52.543
0.330	9.757	1.560	11.317	-39.540	50.857
0.470	9.764	0.560	10.324	-36.533	46.857
0.849	9.770	3.560	13.330	-32.670	46.000
11.185	10.080	18.960	29.040	-20.960	50.000

Note:

1. All Reading Levels are Quasi-Peak and average value.
2. "■" means the worst emission level.
3. Measurement Level = Reading Level + Correct Factor

Product : SpectraGuard® Access Point / Sensor
 Test Item : Conducted Emission Test
 Power Line : Line 1
 Test Mode : Mode 6: Transmit (802.11n-40BW 30Mbps)(PIFA Antenna) (5550MHz)

Frequency MHz	Correct Factor dB	Reading Level dBuV	Measurement Level dBuV	Margin dB	Limit dBuV
LINE 1					
Quasi-Peak					
0.173	9.936	39.670	49.606	-15.737	65.343
0.205	9.910	36.720	46.630	-17.799	64.429
0.396	9.869	21.440	31.309	-27.662	58.971
0.584	9.818	20.750	30.568	-25.432	56.000
0.857	9.770	21.270	31.040	-24.960	56.000
11.205	10.210	33.630	43.840	-16.160	60.000
Average					
0.173	9.936	16.780	26.716	-28.627	55.343
0.205	9.910	12.910	22.820	-31.609	54.429
0.396	9.869	3.280	13.149	-35.822	48.971
0.584	9.818	11.590	21.408	-24.592	46.000
0.857	9.770	11.610	21.380	-24.620	46.000
11.205	10.210	26.410	36.620	-13.380	50.000

Note:

1. All Reading Levels are Quasi-Peak and average value.
2. "■" means the worst emission level.
3. Measurement Level = Reading Level + Correct Factor

Product : SpectraGuard® Access Point / Sensor
 Test Item : Conducted Emission Test
 Power Line : Line 2
 Test Mode : Mode 6: Transmit (802.11n-40BW 30Mbps)(PIFA Antenna) (5550MHz)

Frequency MHz	Correct Factor dB	Reading Level dBuV	Measurement Level dBuV	Margin dB	Limit dBuV
LINE 2					
Quasi-Peak					
0.181	9.780	33.660	43.440	-21.674	65.114
0.255	9.758	26.970	36.728	-26.272	63.000
0.345	9.760	19.840	29.600	-30.829	60.429
0.463	9.761	12.330	22.091	-34.966	57.057
1.115	9.790	13.100	22.890	-33.110	56.000
10.916	10.080	27.750	37.830	-22.170	60.000
Average					
0.181	9.780	6.390	16.170	-38.944	55.114
0.255	9.758	0.520	10.278	-42.722	53.000
0.345	9.760	6.910	16.670	-33.759	50.429
0.463	9.761	-1.020	8.741	-38.316	47.057
1.115	9.790	2.560	12.350	-33.650	46.000
10.916	10.080	18.520	28.600	-21.400	50.000

Note:

1. All Reading Levels are Quasi-Peak and average value.
2. "■" means the worst emission level.
3. Measurement Level = Reading Level + Correct Factor

3. Maximun conducted output power

3.1. Test Equipment

	Equipment	Manufacturer	Model No./Serial No.	Last Cal.
X	Power Meter	Anritsu	ML2495A/6K00003357	May, 2013
X	Power Sensor	Anritsu	MA2411B/0738448	Jun, 2013
X	Spectrum Analyzer	Agilent	N9010A / MY48030495	Apr., 2013

Note:

1. All equipments are calibrated with traceable calibrations. Each calibration is traceable to the national or international standards.
2. The test instruments marked with “X” are used to measure the final test results.

3.2. Test Setup

26dBc Occupied Bandwidth

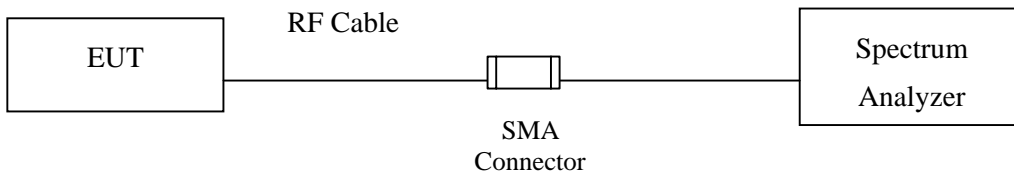

Conduction Power Measurement

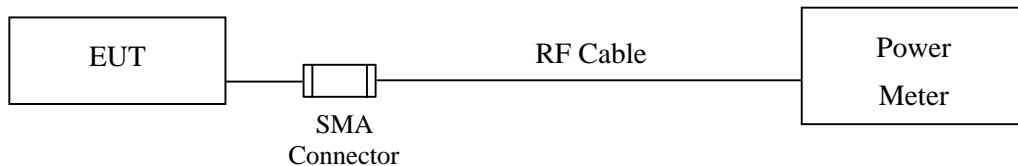

3.3. Limits

- For the band 5.15-5.25 GHz, the maximum conducted output power over the frequency band of operation shall not exceed the lesser of 50 mW or $4 \text{ dBm} + 10\log B$, where B is the 26-dB emission bandwidth in MHz. If transmitting antenna of directional gain greater than 6 dBi are used, the peak transmit power shall be reduced by the amount in dB that directional gain of the antenna exceeds 6 dBi.
- For the band 5.25-5.35 GHz, the maximum conducted output power over the frequency band of operation shall not exceed the lesser of 250 mW or $11 \text{ dBm} + 10\log B$, where B is the 26-dB emission bandwidth in MHz. If transmitting antenna of directional gain greater than 6 dBi are used, the peak transmit power shall be reduced by the amount in dB that directional gain of the antenna exceeds 6 dBi.
- For the band 5.725-5.825 GHz, the maximum conducted output power over the frequency band of operation shall not exceed the lesser of 1W or $17 \text{ dBm} + 10\log B$, where B is the 26-dB emission bandwidth in MHz. If transmitting antenna of directional gain greater than 6 dBi are used, the peak transmit power shall be reduced by the amount in dB that directional gain of the antenna exceeds 6 dBi.

3.4. Test Procedur

As an alternative to FCC KDB-789033, the EUT maximum conducted output power was measured with an average power meter employing a video bandwidth greater than 6dB BW of the emission under test. Maximum conducted output power was read directly from the meter across all data rates, and across three channels within each sub-band. Special care was used to make sure that the EUT was transmitting in continuous mode. This method exceeds the limitations of FCC KDB-789033, and provides more accurate measurements.

The Maximum conducted output power using KDB 789033 section E)3)b) Method PM-G (Measurement using a gated RF average power meter).

3.5. Uncertainty

$\pm 1.27 \text{ dB}$

3.6. Test Result of Maximum conducted output power

Product : SpectraGuard® Access Point / Sensor
 Test Item : Maximum conducted output power
 Test Site : No.3 OATS
 Test Mode : Mode 1: Transmit (802.11a-6Mbps)(Dipole Antenna)

CHAIN A

Cable loss=1dB		Maximum conducted output power								
Channel No.	Frequency (MHz)	Data Rate (Mbps)								Required Limit
		6	9	12	18	24	36	48	54	
		Measurement Level (dBm)								
52	5260	16.43	--	--	--	--	--	--	--	<24dBm
60	5300	17.01	16.9	16.83	16.77	16.62	16.48	16.22	16.1	<24dBm
64	5320	15.05	--	--	--	--	--	--	--	<24dBm
100	5500	14.63	--	--	--	--	--	--	--	<24dBm
116	5580	17.28	17.11	17.04	16.95	16.81	16.66	16.46	16.32	<24dBm
140	5700	17.31	--	--	--	--	--	--	--	<24dBm

Note: 1.Maximum conducted output power Value =Reading value on average power meter + cable loss

CHAIN B

Cable loss=1dB		Maximum conducted output power								
Channel No.	Frequency (MHz)	Data Rate (Mbps)								Required Limit
		6	9	12	18	24	36	48	54	
		Measurement Level (dBm)								
52	5260	17.51	--	--	--	--	--	--	--	<24dBm
60	5300	17.73	17.62	17.55	17.41	17.36	17.22	17.08	16.9	<24dBm
64	5320	15.51	--	--	--	--	--	--	--	<24dBm
100	5500	16.18	--	--	--	--	--	--	--	<24dBm
116	5580	17.17	17.04	16.91	16.78	16.64	16.46	16.23	16.11	<24dBm
140	5700	17.33	--	--	--	--	--	--	--	<24dBm

Note: 1.Maximum conducted output power Value =Reading value on average power meter + cable loss

Maximum conducted output power Measurement:

(CHAIN A+ B)

Channel Number	Frequency (MHz)	26dB Bandwidth (MHz)	Chain A Power (dBm)	Chain B Power (dBm)	Output Power (dBm)	Output Power Limit	
						(dBm)	dBm+10log(BW)
52	5260	24.350	16.43	17.51	20.01	24	24.86
60	5300	22.700	17.01	17.73	20.40	24	24.56
64	5320	21.950	15.05	15.51	18.30	24	24.41
100	5500	21.650	14.63	16.18	18.48	24	24.35
116	5580	24.500	17.28	17.17	20.24	24	24.89
140	5700	23.850	17.31	17.33	20.33	24	24.77

Note:

1. Power Output Value =Reading value on average power meter + cable loss
2. Output Power (dBm) = 10LOG (Chain A Power (mW)+ Chain B Power (mW))
3. 26 dB Bandwidth is the bandwidth of chain A or chain B whichever is less bandwidth, output power limitation is more stringent.

26dBc Occupied Bandwidth:

Channel 52: CHAIN A

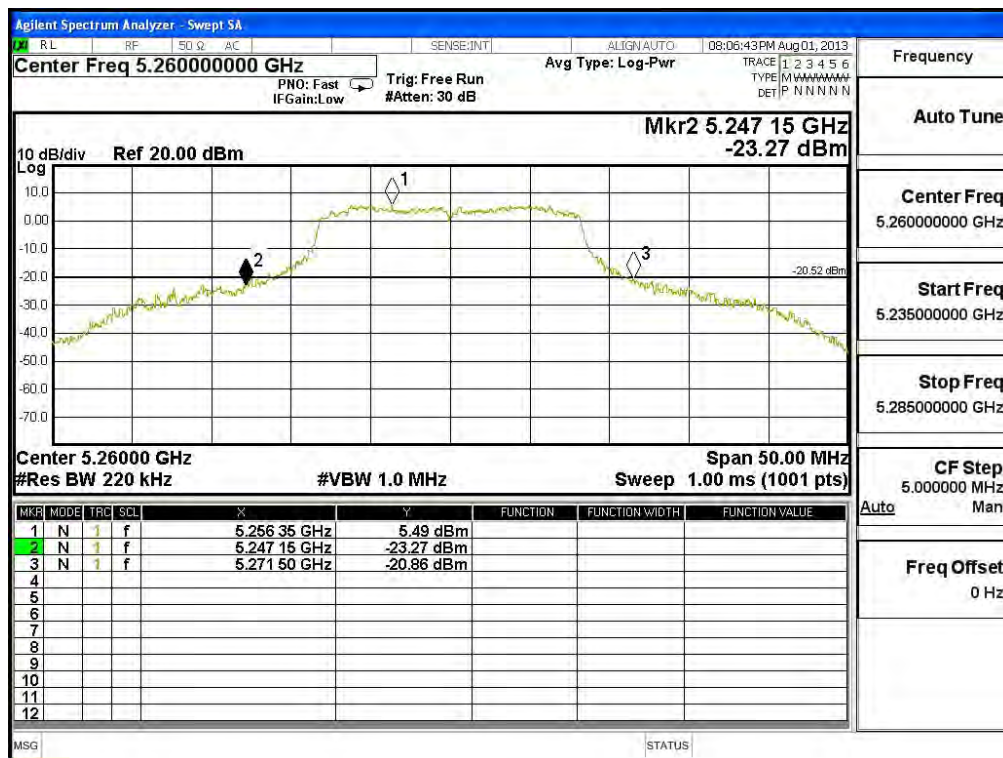

Channel 60: CHAIN A

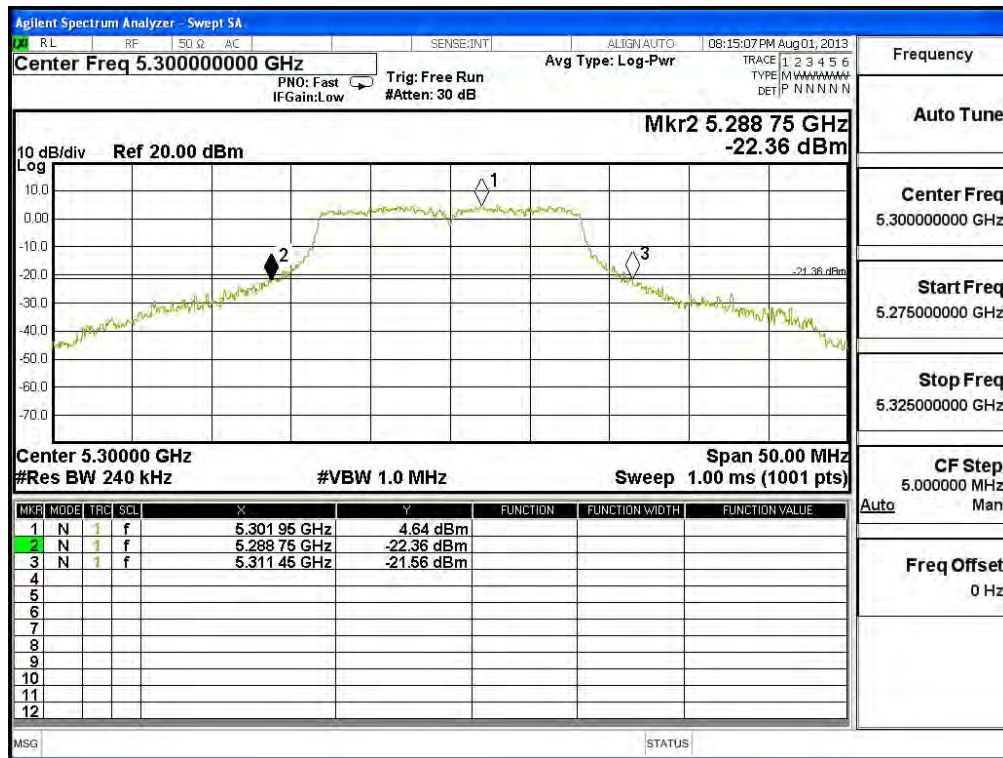

Frequency
Auto Tune
Center Freq 5.30000000 GHz
Start Freq 5.27500000 GHz
Stop Freq 5.32500000 GHz
CF Step 5.000000 MHz Auto Man
Freq Offset 0 Hz

Channel 64: CHAIN A

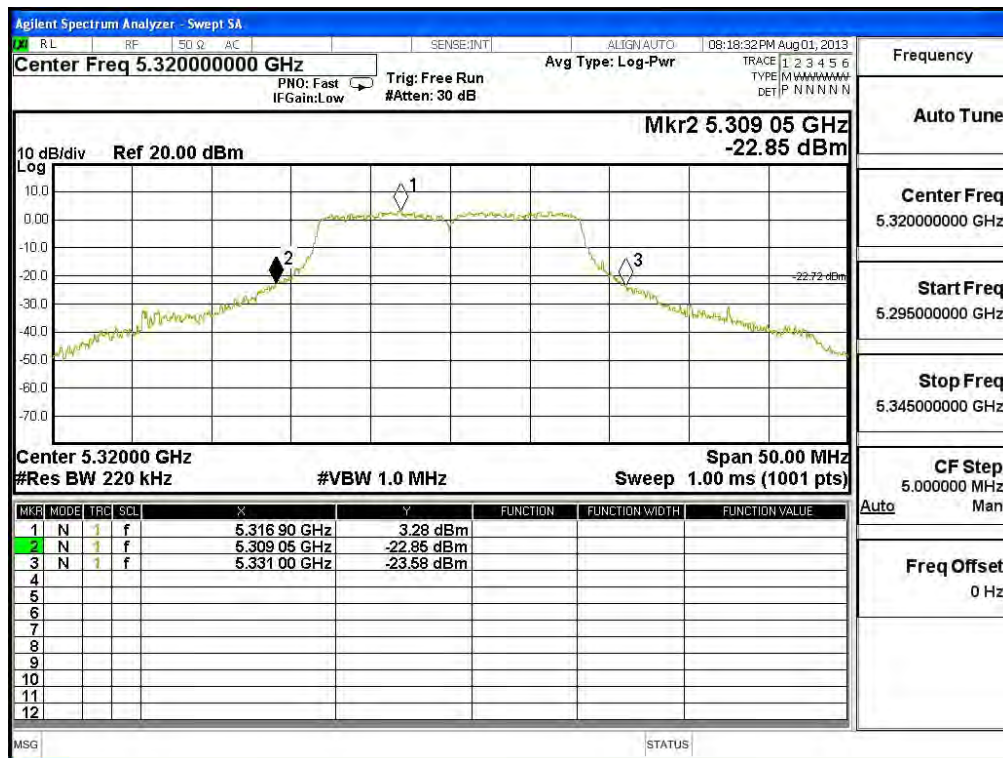

Frequency
Auto Tune
Center Freq 5.32000000 GHz
Start Freq 5.29500000 GHz
Stop Freq 5.34500000 GHz
CF Step 5.000000 MHz Auto Man
Freq Offset 0 Hz

Channel 100: CHAIN A

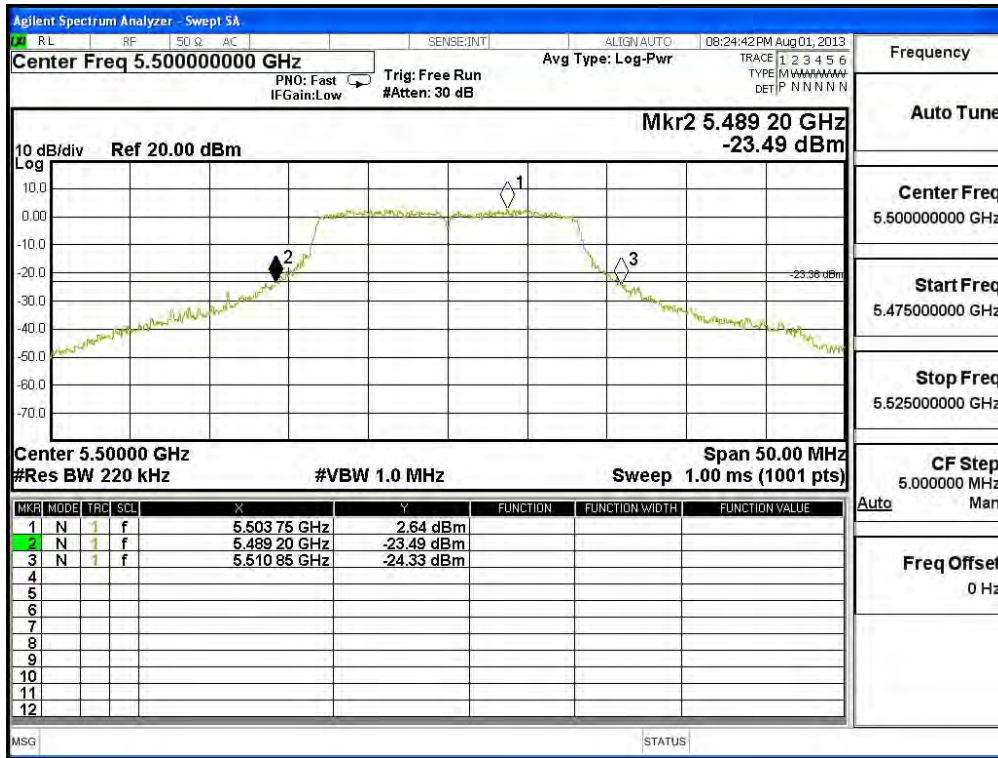

Channel 120: CHAIN A

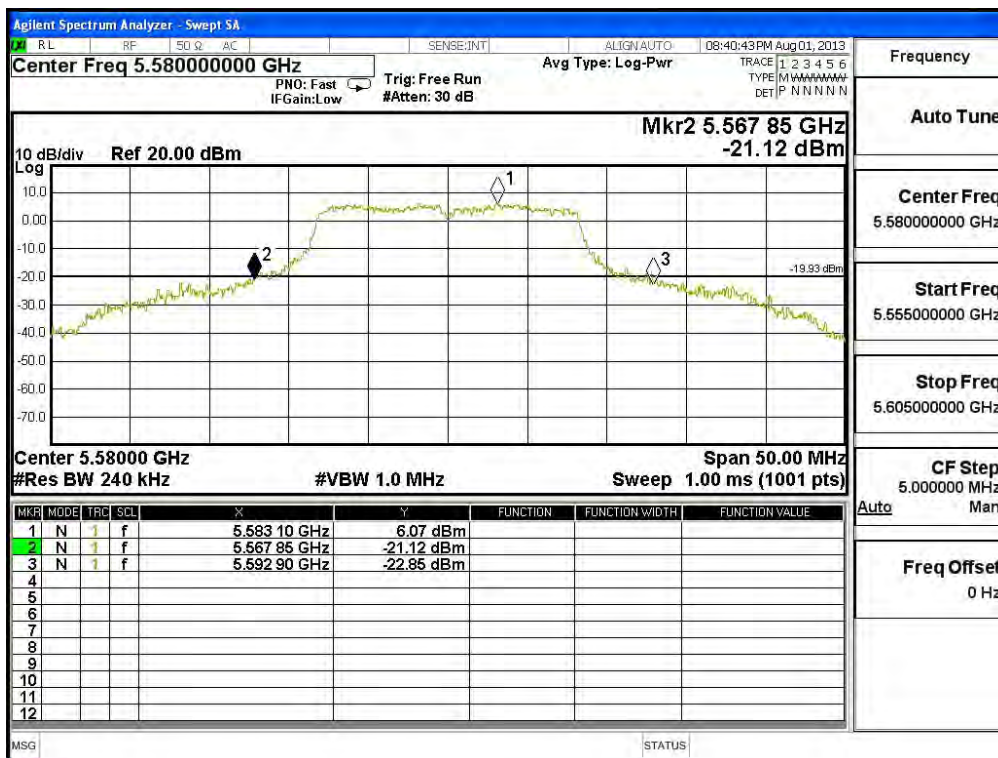

Channel 140: CHAIN A

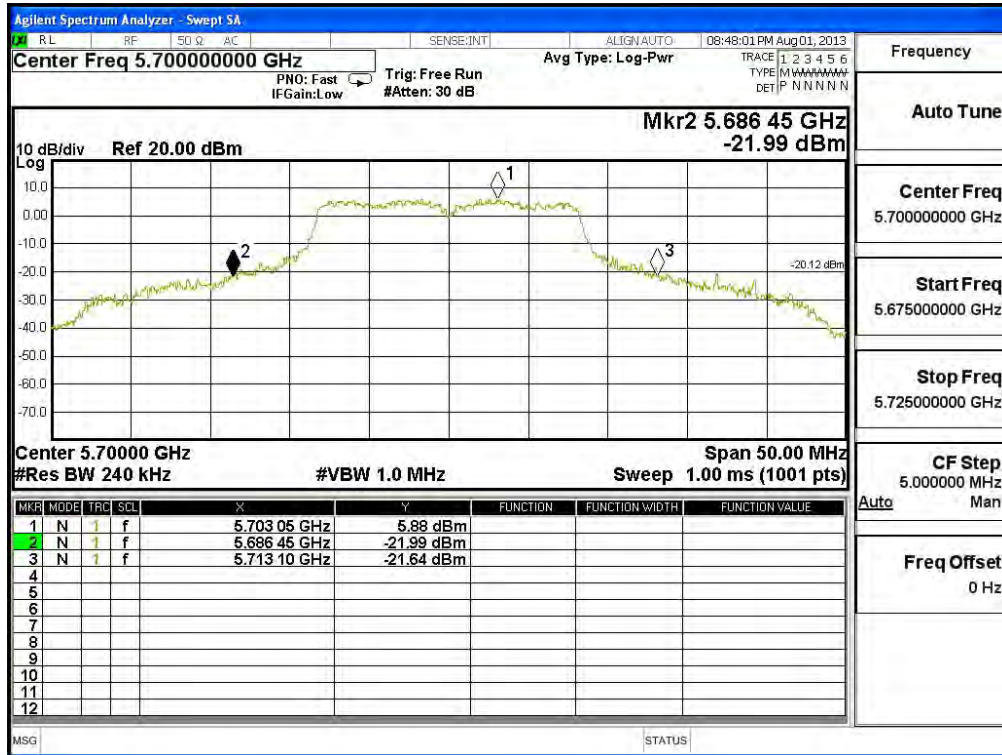

**26dBc Occupied Bandwidth:
Channel 52: CHAIN B**

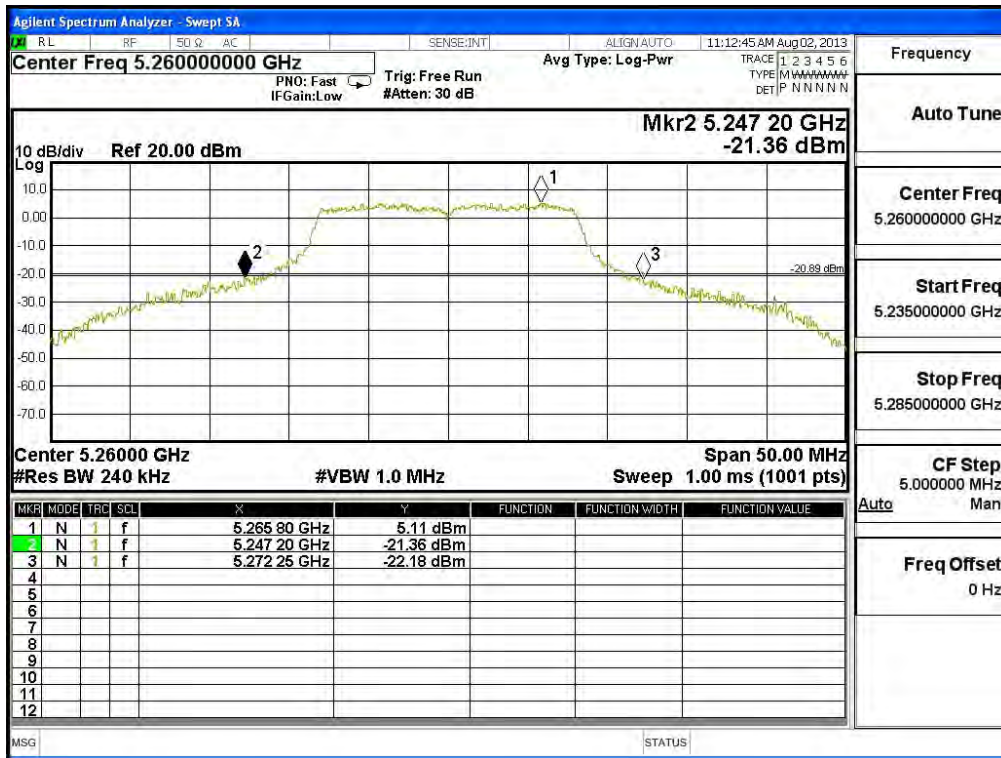

Channel 60: CHAIN B

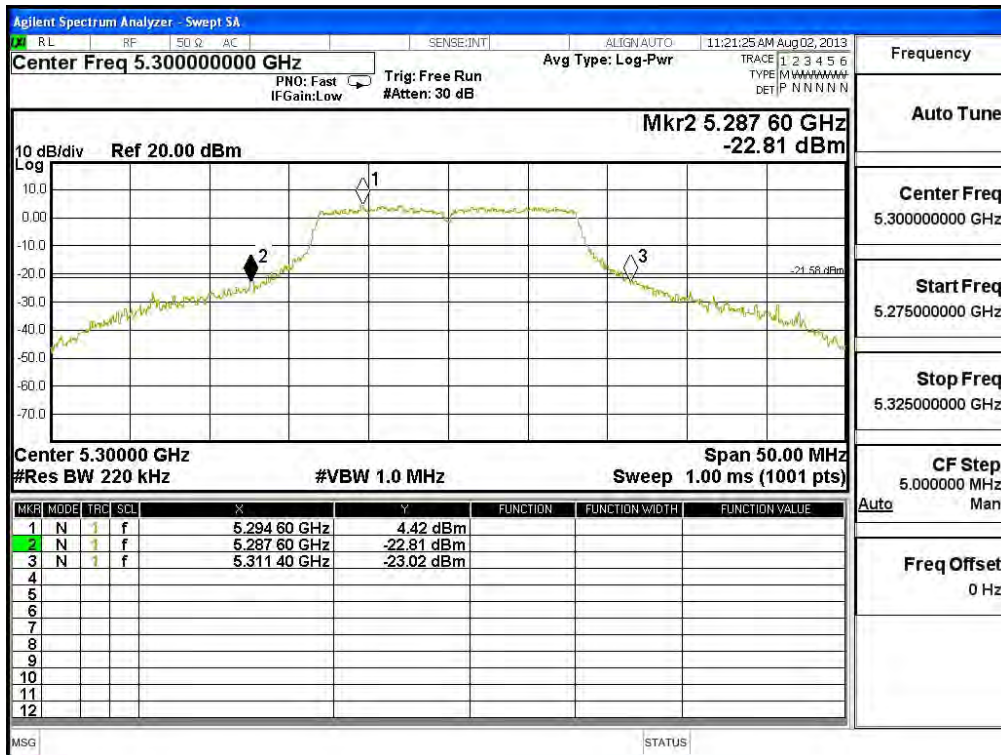

Channel 64: CHAIN B

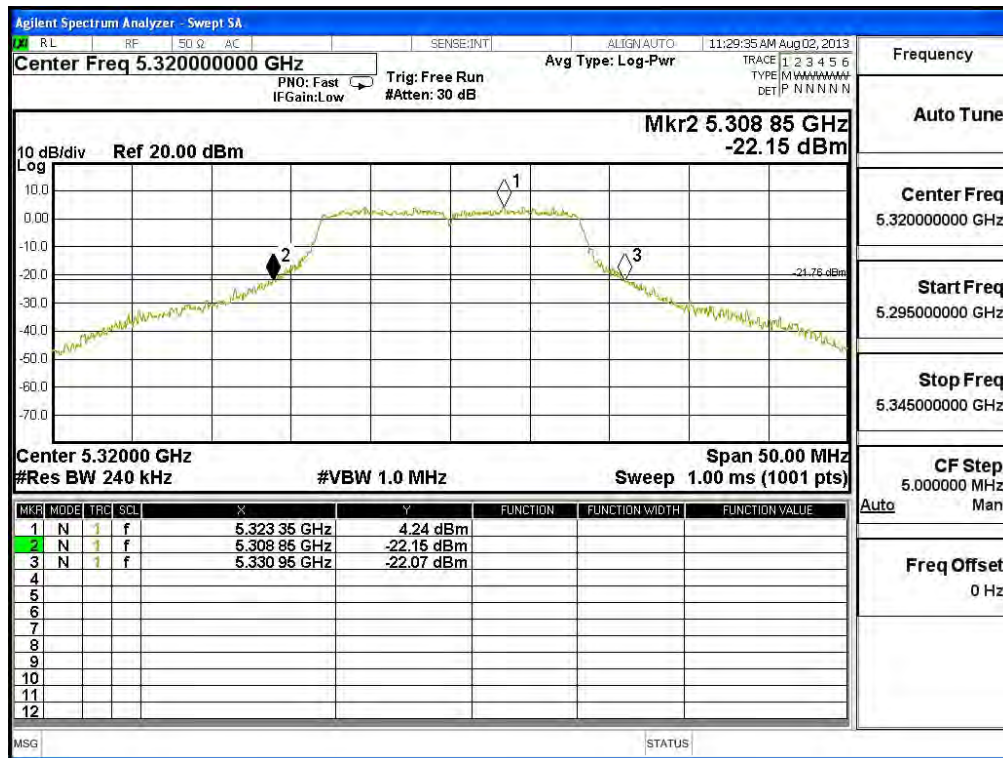

Frequency
Auto Tune
Center Freq 5.32000000 GHz
Start Freq 5.29500000 GHz
Stop Freq 5.34500000 GHz
CF Step 5.000000 MHz
Auto Man
Freq Offset 0 Hz

Channel 100: CHAIN B

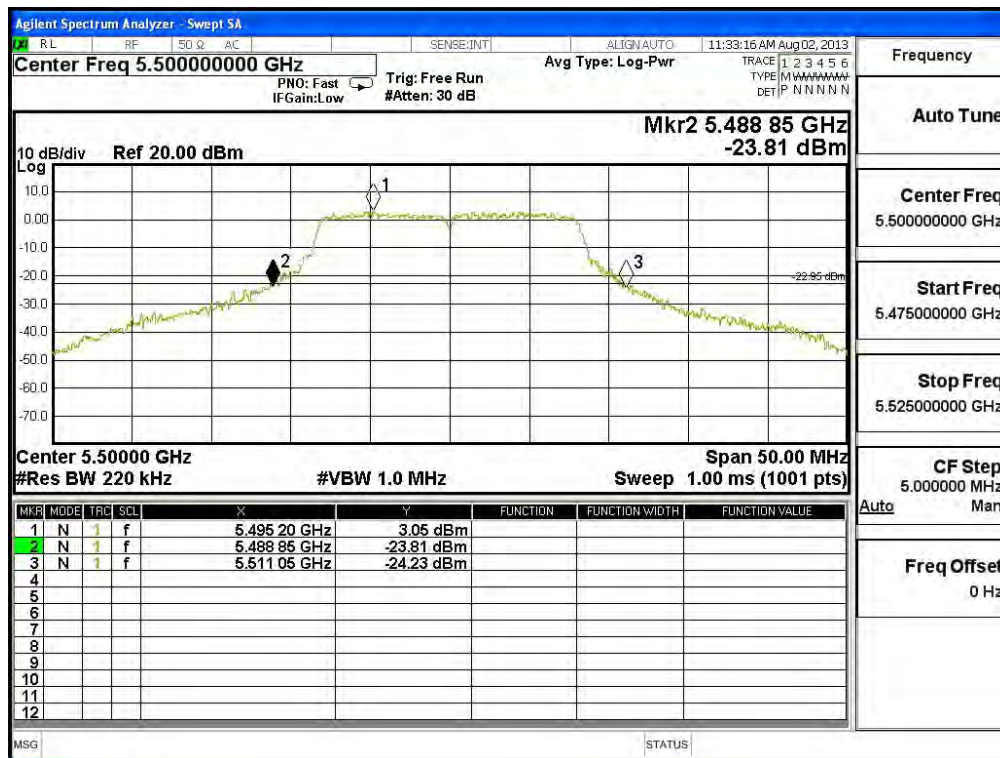

Frequency
Auto Tune
Center Freq 5.50000000 GHz
Start Freq 5.47500000 GHz
Stop Freq 5.52500000 GHz
CF Step 5.000000 MHz
Auto Man
Freq Offset 0 Hz

Channel 120: CHAIN B

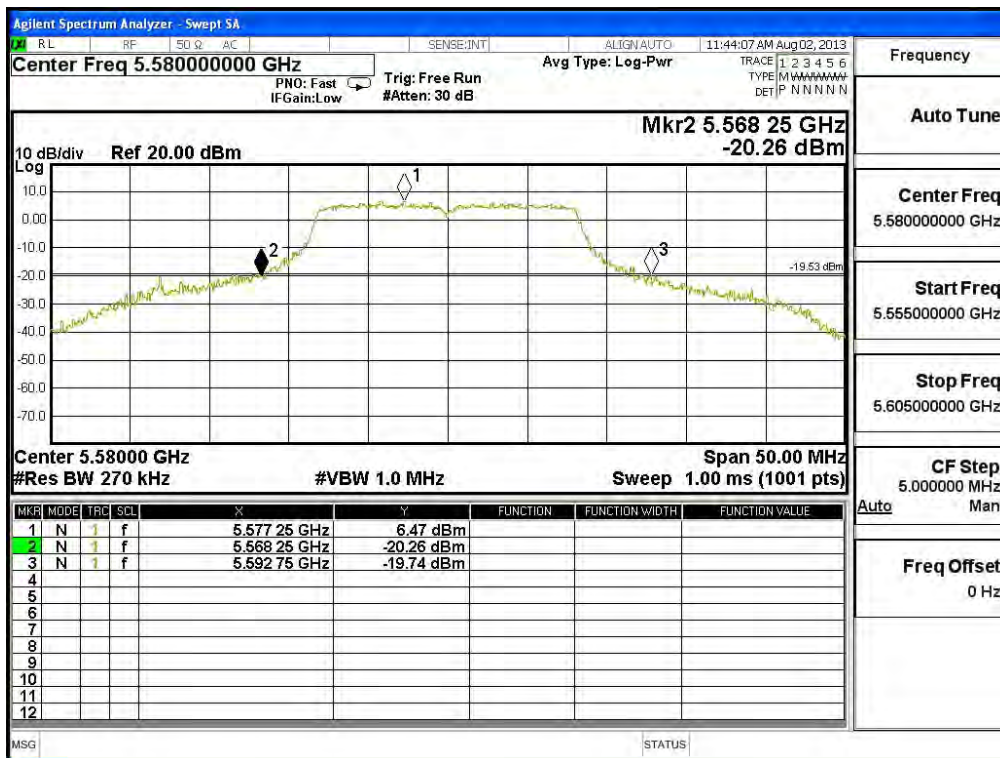

Channel 140: CHAIN B

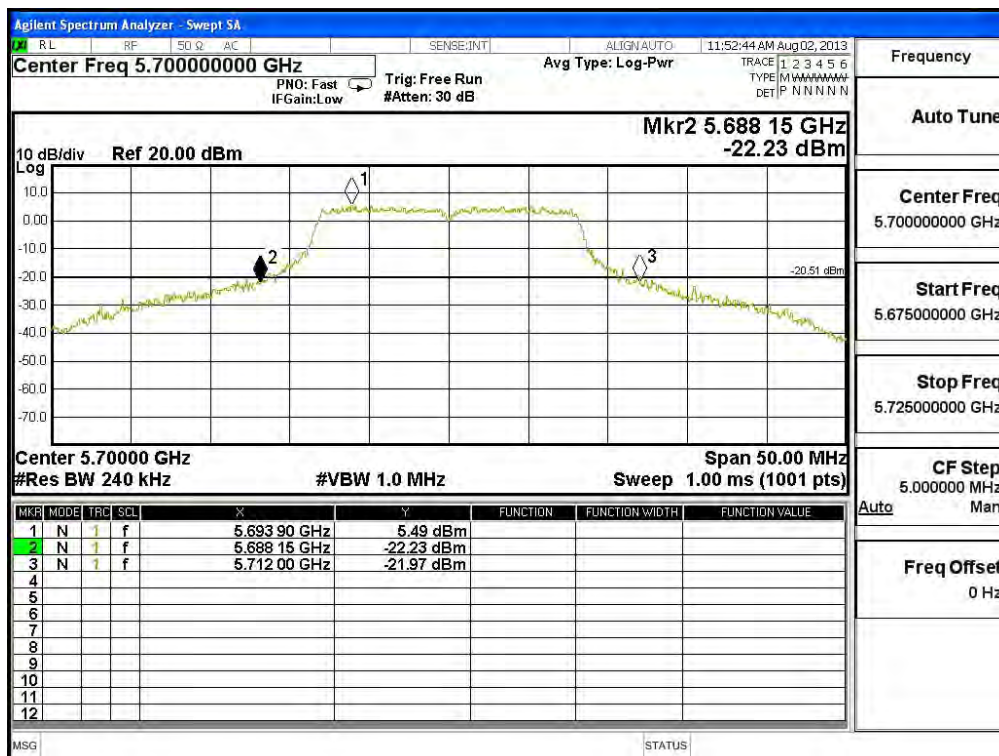

Product : SpectraGuard® Access Point / Sensor
 Test Item : Maximum conducted output power
 Test Site : No.3 OATS
 Test Mode : Mode 2: Transmit (802.11n-20BW 14.4Mbps)(Dipole Antenna)

CHAIN A

Cable loss=1dB		Maximum conducted output power								
Channel No.	Frequency (MHz)	Data Rate (Mbps)								Required Limit
		14.4	28.9	43.3	57.8	86.7	115.6	130	144.4	
		Measurement Level (dBm)								
52	5260	16.00	--	--	--	--	--	--	--	<24dBm
60	5300	15.81	15.69	15.54	15.38	15.24	15.09	14.97	14.83	<24dBm
64	5320	14.22	--	--	--	--	--	--	--	<24dBm
100	5500	13.48	--	--	--	--	--	--	--	<24dBm
116	5580	17.47	17.33	17.21	17.09	16.93	16.77	16.63	16.49	<24dBm
140	5700	17.33	--	--	--	--	--	--	--	<24dBm

Note: 1.Maximum conducted output power Value =Reading value on average power meter + cable loss

CHAIN B

Cable loss=1dB		Maximum conducted output power								
Channel No.	Frequency (MHz)	Data Rate (Mbps)								Required Limit
		14.4	28.9	43.3	57.8	86.7	115.6	130	144.4	
		Measurement Level (dBm)								
52	5260	17.37	--	--	--	--	--	--	--	<24dBm
60	5300	17.42	17.31	17.28	17.11	17.02	16.94	16.82	16.71	<24dBm
64	5320	15.25	--	--	--	--	--	--	--	<24dBm
100	5500	15.91	--	--	--	--	--	--	--	<24dBm
116	5580	18.00	17.92	17.78	17.66	17.44	17.37	17.22	17.06	<24dBm
140	5700	17.83	--	--	--	--	--	--	--	<24dBm

Note: 1.Maximum conducted output power Value =Reading value on average power meter + cable loss

Maximum conducted output power Measurement:
(CHAIN A+ B)

Channel Number	Frequency (MHz)	26dB Bandwidth (MHz)	Chain A Power (dBm)	Chain B Power (dBm)	Output Power (dBm)	Output Power Limit	
						(dBm)	dBm+10log(BW)
52	5260	22.850	16.00	17.37	19.75	24	24.59
60	5300	22.100	15.81	17.42	19.70	24	24.44
64	5320	21.650	14.22	15.25	17.78	24	24.35
100	5500	22.250	13.48	15.91	17.87	24	24.47
116	5580	22.350	17.47	18.00	20.75	24	24.49
140	5700	22.850	17.33	17.83	20.60	24	24.59

Note:

1. Power Output Value = Reading value on average power meter + cable loss
2. Output Power (dBm) = 10LOG (Chain A Power (mW)+ Chain B Power (mW))
3. 26 dB Bandwidth is the bandwidth of chain A or chain B whichever is less bandwidth, output power limitation is more stringent.

**26dBc Occupied Bandwidth:
Channel 52 -Chain A**

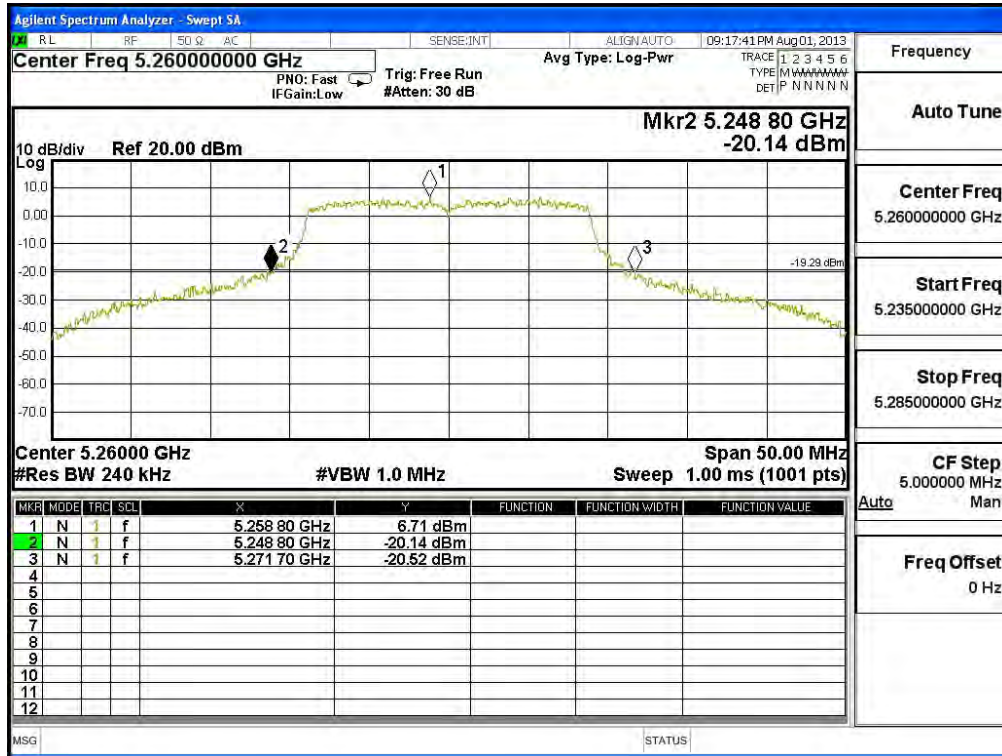

Channel 60 -Chain A

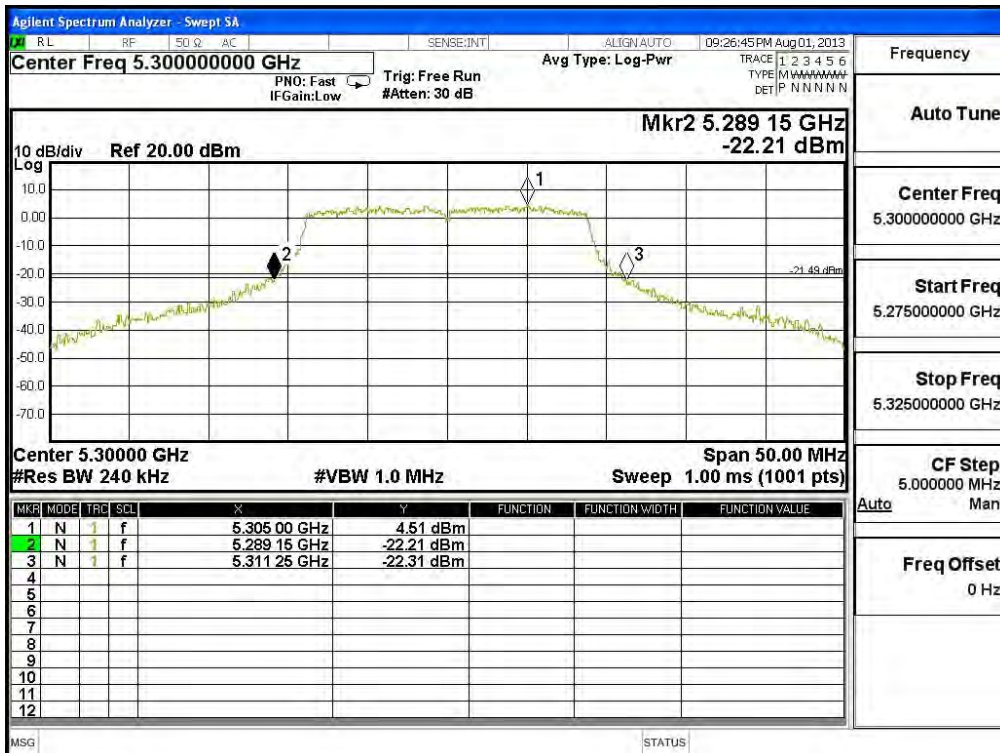

Channel 64 -Chain A

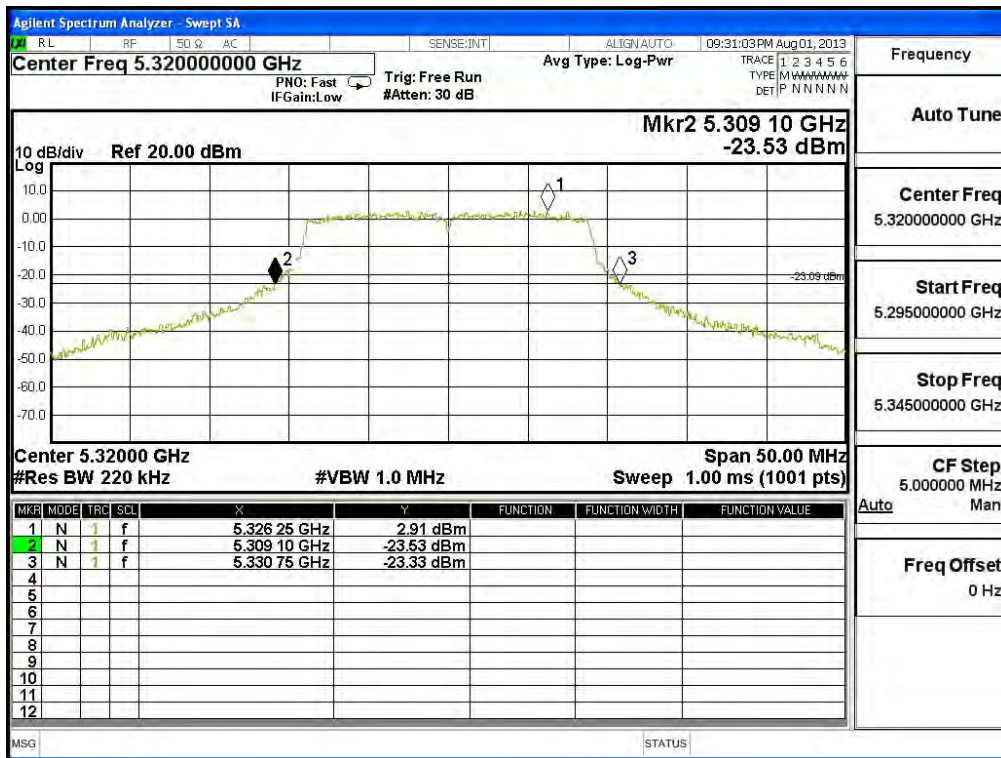

Channel 100 -Chain A

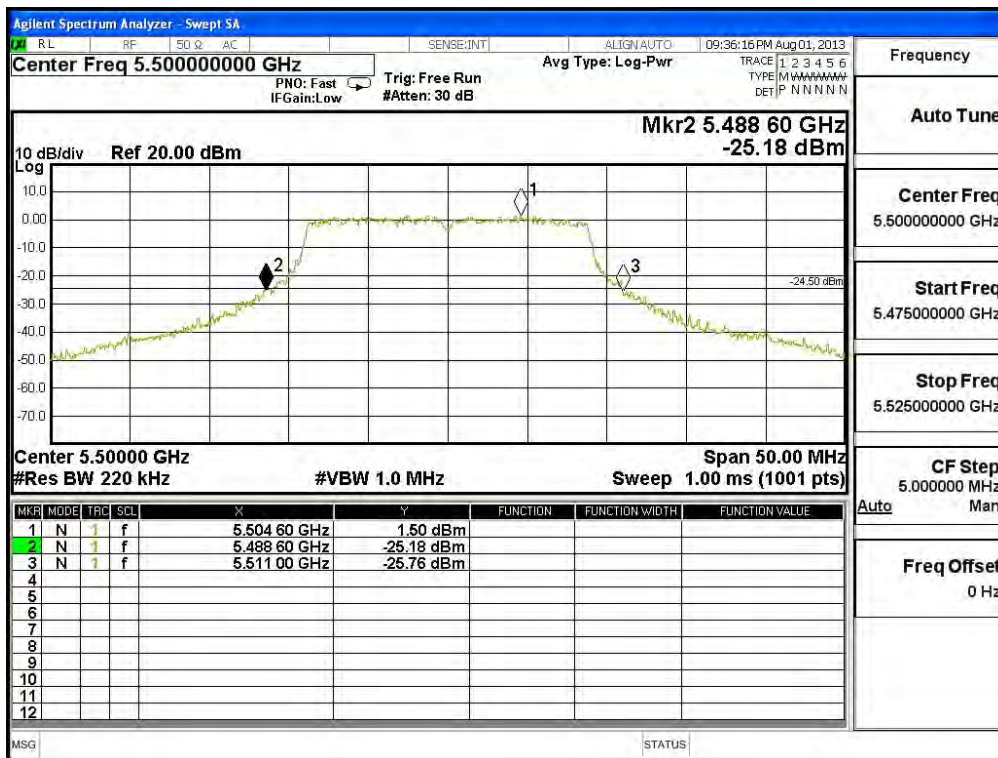

Channel 120 -Chain A

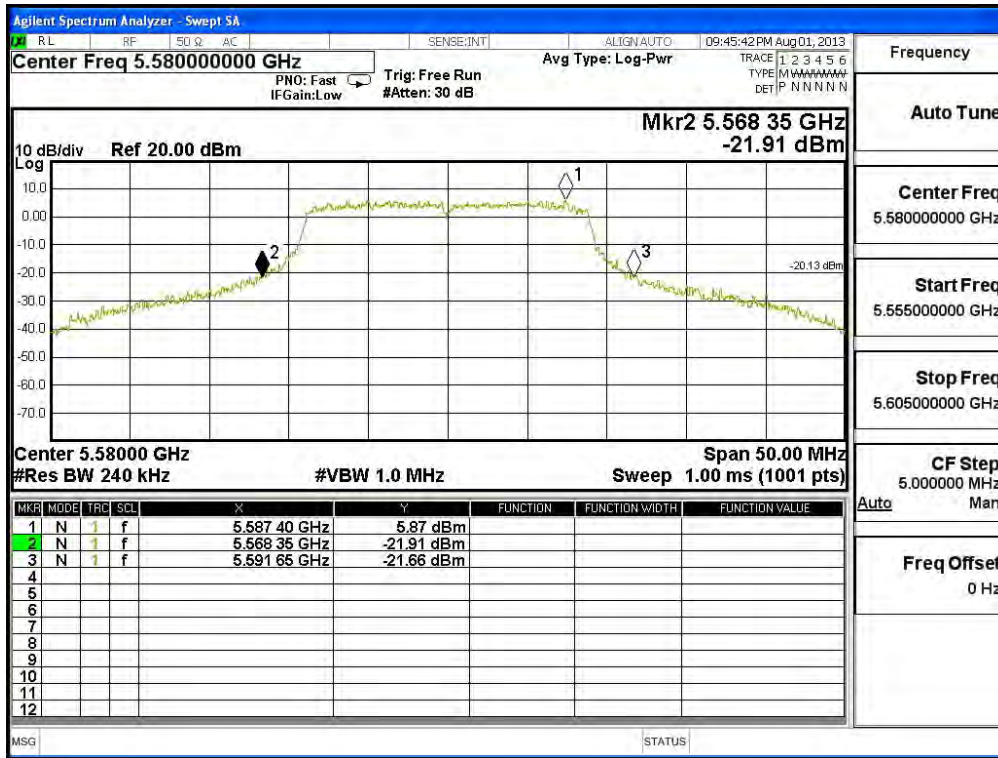

Channel 140 -Chain A

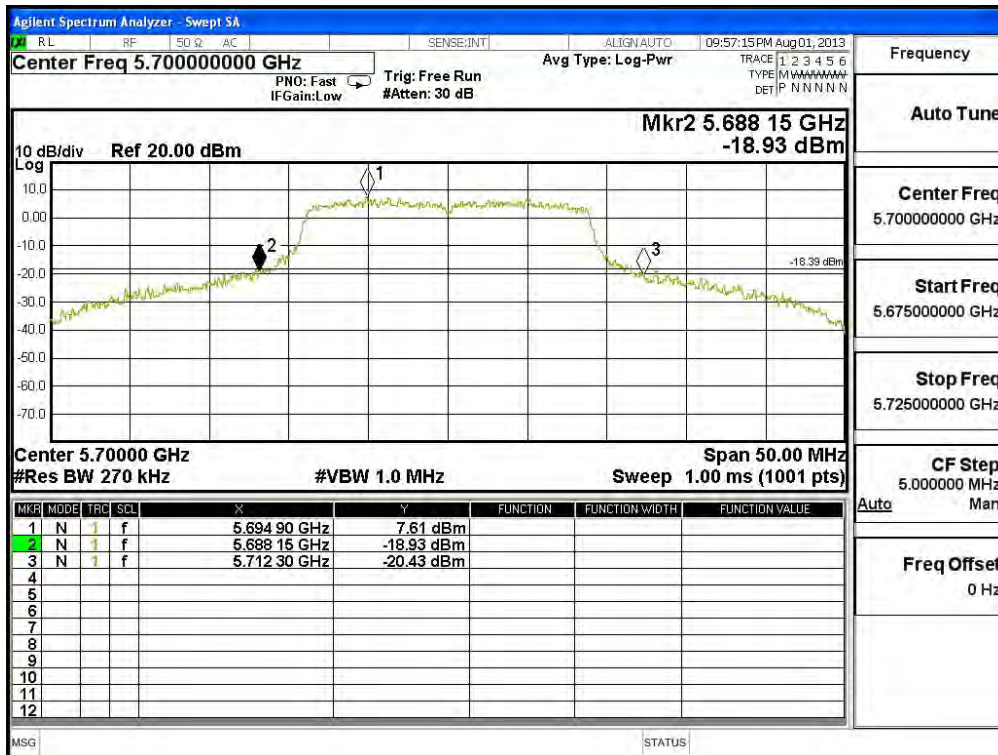

Channel 52 -Chain B

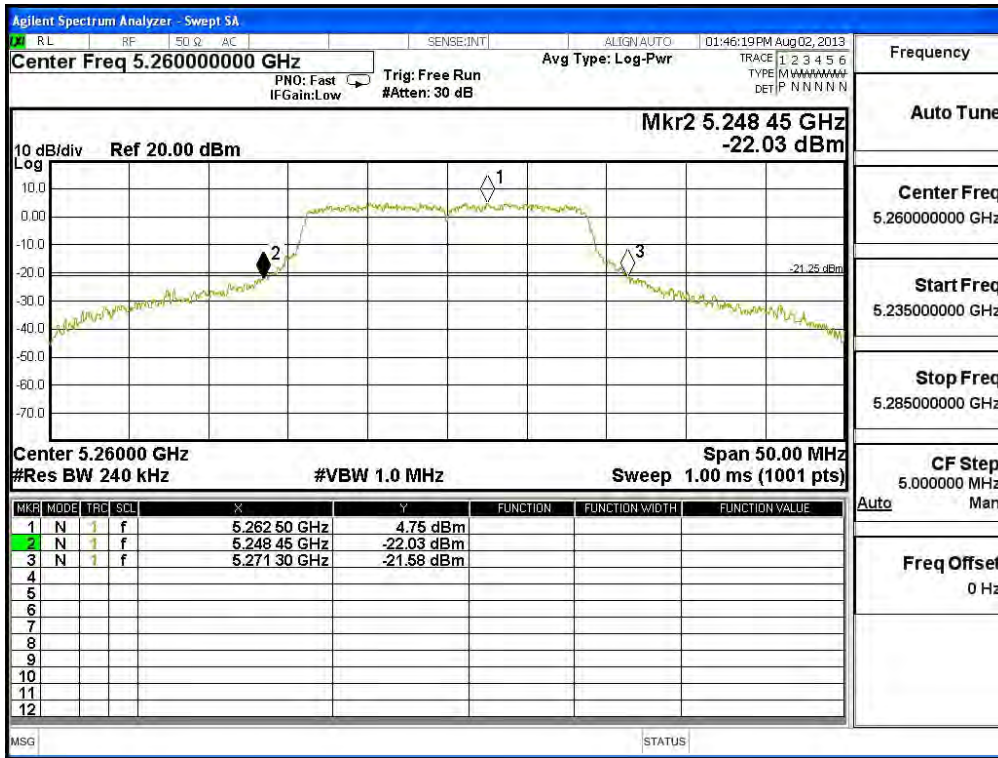

Channel 60 -Chain B

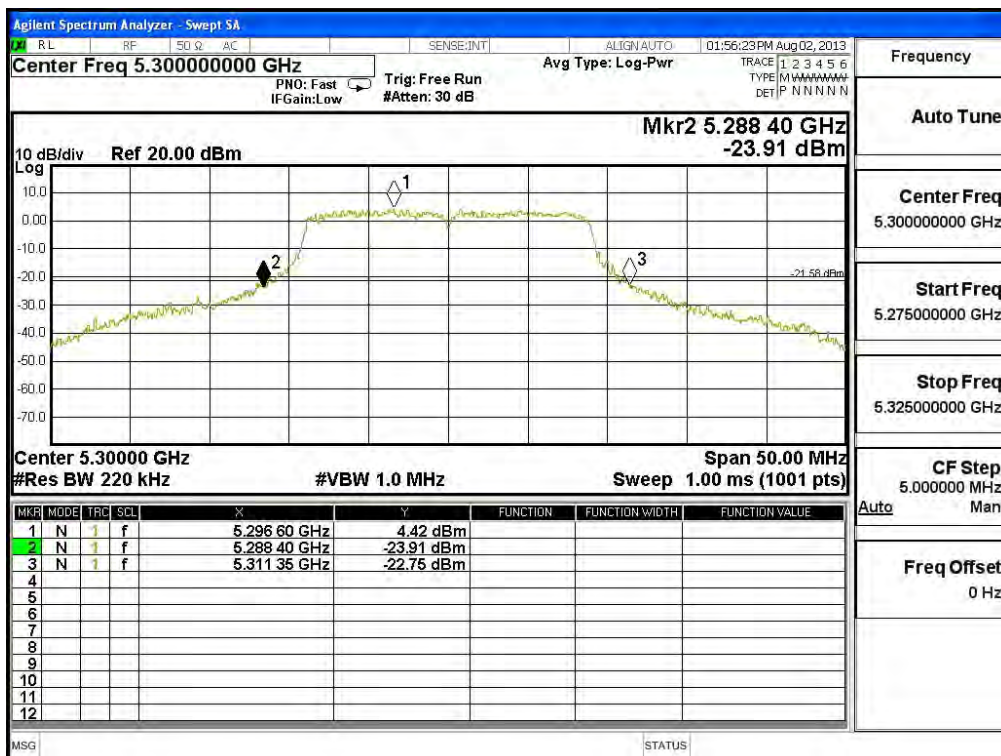

Channel 64 -Chain B

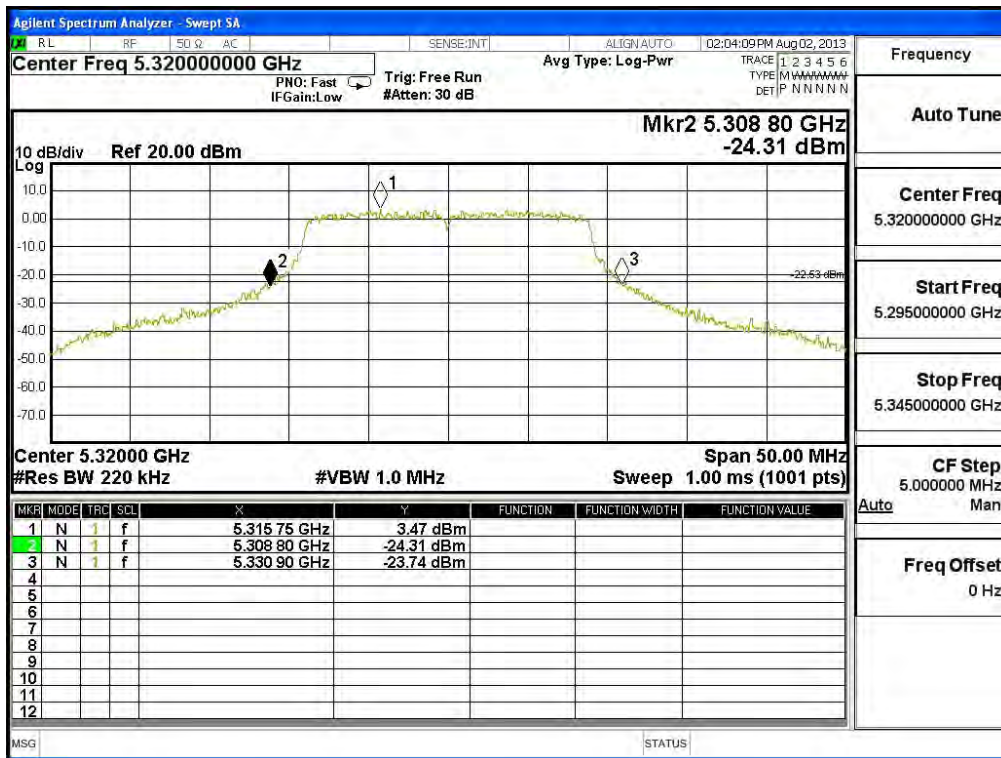

Channel 100 -Chain B

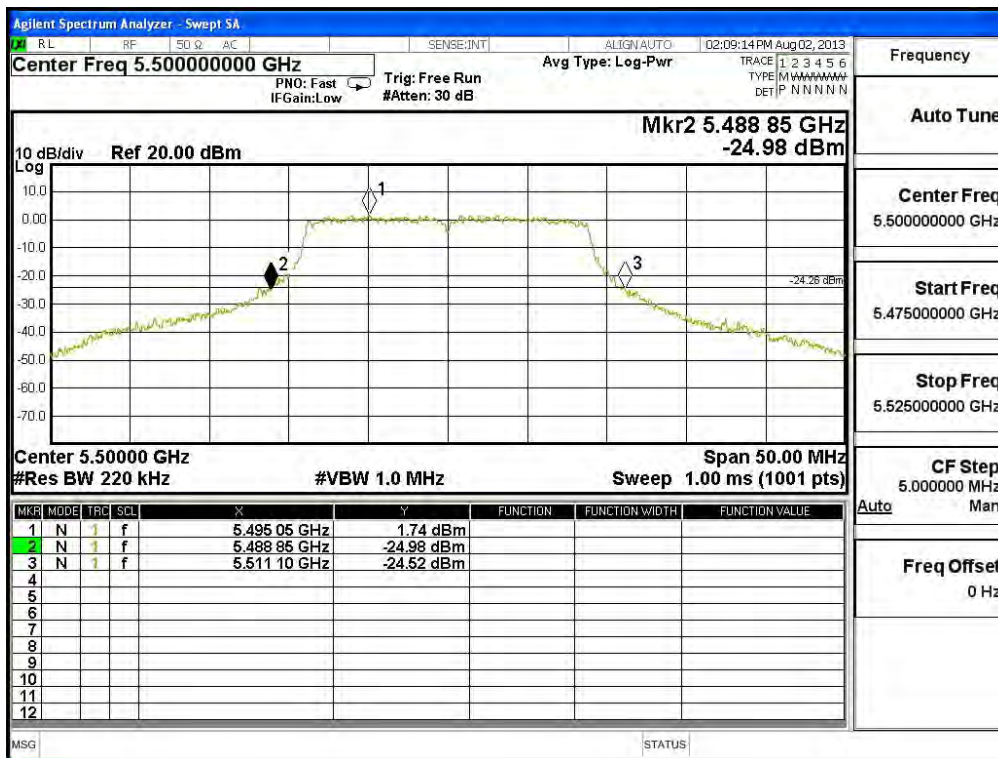

Channel 120 -Chain B

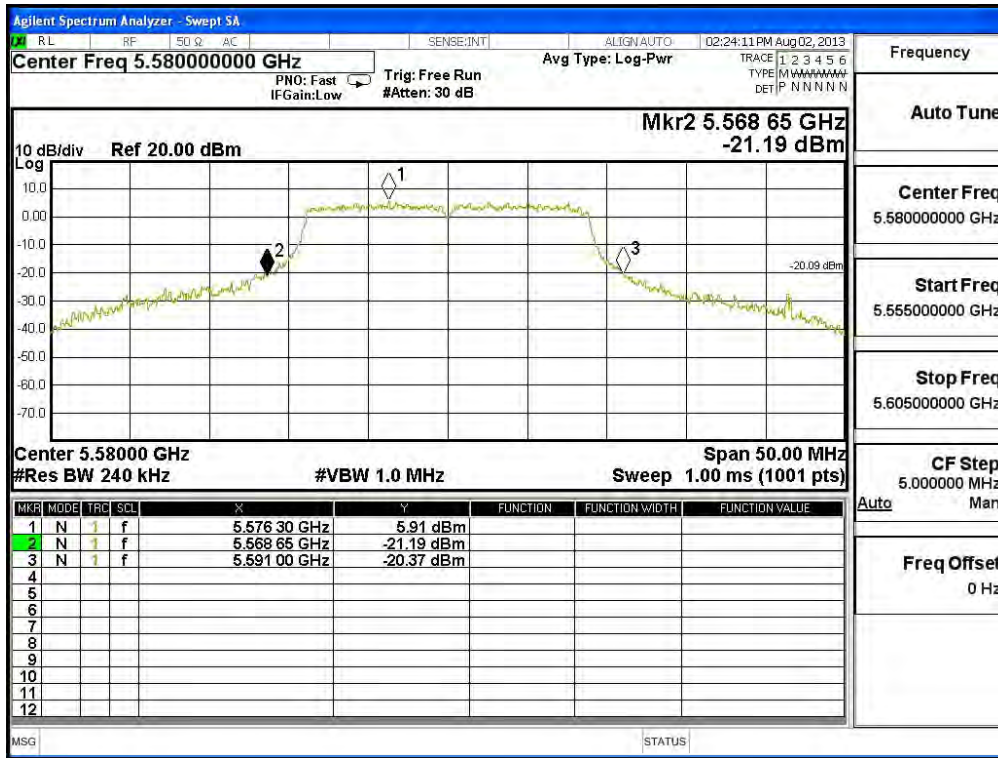

Channel 140 -Chain B

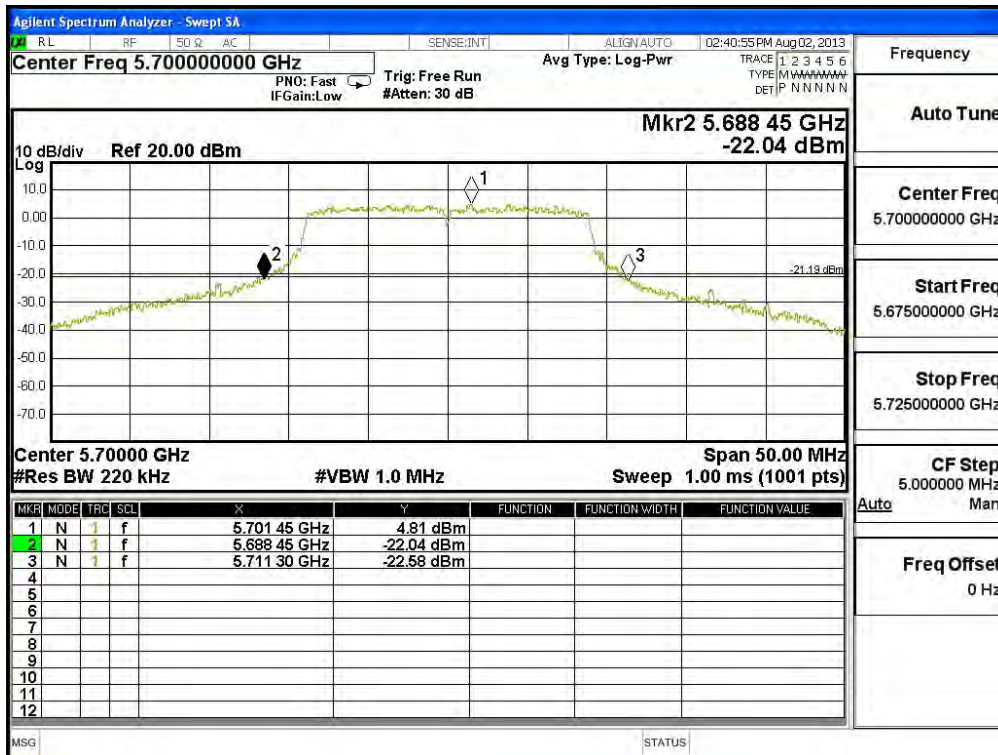

Product : SpectraGuard® Access Point / Sensor
 Test Item : Maximum conducted output power
 Test Site : No.3 OATS
 Test Mode : Mode 3: Transmit (802.11n-40BW 30Mbps)(Dipole Antenna)

CHAIN A

Cable loss=1dB		Maximum conducted output power								
Channel No.	Frequency (MHz)	Data Rate (Mbps)								Required Limit
		30	60	90	120	180	240	270	300	
		Measurement Level (dBm)								
54	5270	15.88	--	--	--	--	--	--	--	<24dBm
62	5310	8.82	8.67	8.52	8.41	8.29	8.11	8.02	7.89	<24dBm
102	5510	10.59	--	--	--	--	--	--	--	<24dBm
110	5550	13.48	13.32	13.27	13.09	12.94	12.76	12.58	12.44	<24dBm
134	5670	16.97	--	--	--	--	--	--	--	<24dBm

Note: 1.Maximum conducted output power Value =Reading value on average power meter + cable loss

CHAIN B

Cable loss=1dB		Maximum conducted output power								
Channel No.	Frequency (MHz)	Data Rate (Mbps)								Required Limit
		30	60	90	120	180	240	270	300	
		Measurement Level (dBm)								
54	5270	17.53	--	--	--	--	--	--	--	<24dBm
62	5310	10.03	9.88	9.71	9.64	9.54	9.41	9.27	9.11	<24dBm
102	5510	13.27	--	--	--	--	--	--	--	<24dBm
110	5550	15.04	14.91	14.77	14.62	14.51	14.43	14.32	14.12	<24dBm
134	5670	17.56	--	--	--	--	--	--	--	<24dBm

Note: 1.Maximum conducted output power Value =Reading value on average power meter + cable loss

Maximum conducted output power Measurement:
(CHAIN A+ B)

Channel Number	Frequency (MHz)	26dB Bandwidth (MHz)	Chain A Power (dBm)	Chain B Power (dBm)	Output Power (dBm)	Output Power Limit	
						(dBm)	dBm+10log(BW)
54	5270	43.200	15.88	17.53	19.79	24	27.35
62	5310	42.100	8.82	10.03	12.48	24	27.24
102	5510	43.300	10.59	13.27	15.14	24	27.36
110	5550	44.000	13.48	15.04	17.34	24	27.43
134	5670	44.300	16.97	17.56	20.29	24	27.46

Note:

1. Power Output Value =Reading value on average power meter + cable loss
2. Output Power (dBm) = 10LOG (Chain A Power (mW)+ Chain B Power (mW))
3. 26 dB Bandwidth is the bandwidth of chain A or chain B whichever is less bandwidth, output power limitation is more stringent.

**26dBc Occupied Bandwidth:
Channel 54 – Chain A**

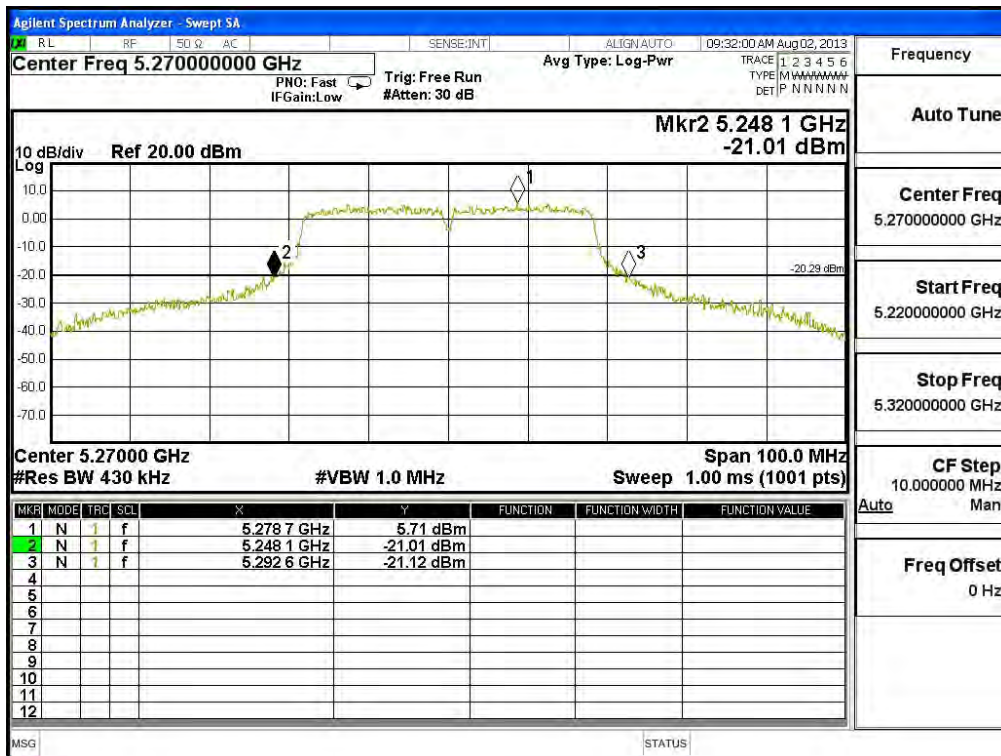

Channel 62 – Chain A

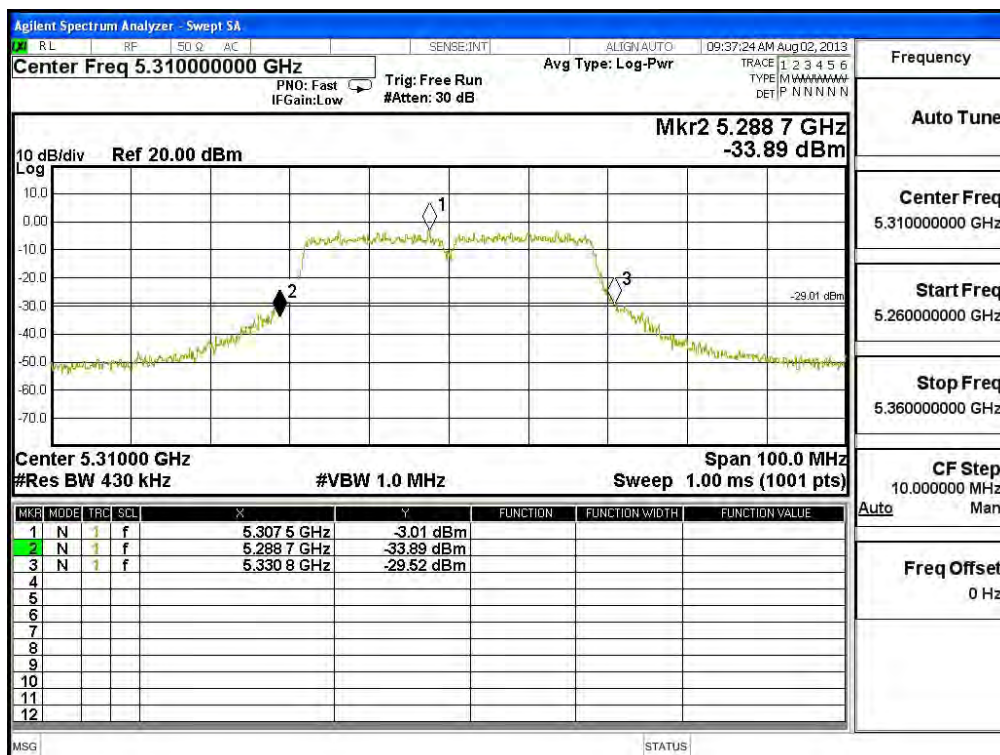

Channel 102 – Chain A

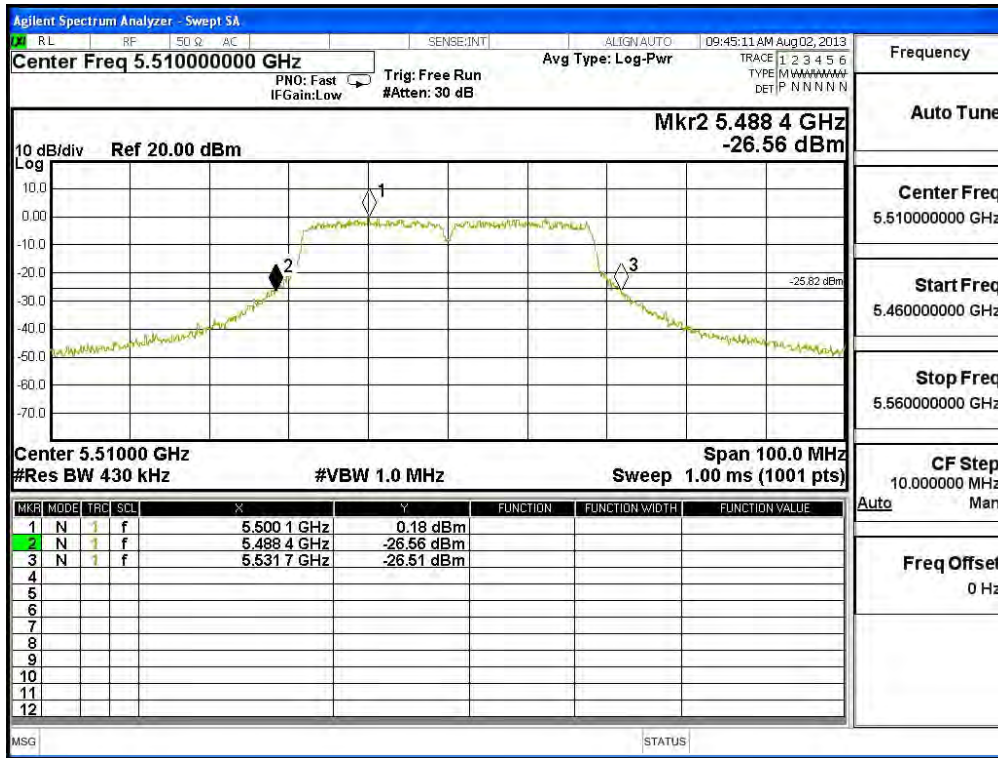

Channel 110 – Chain A

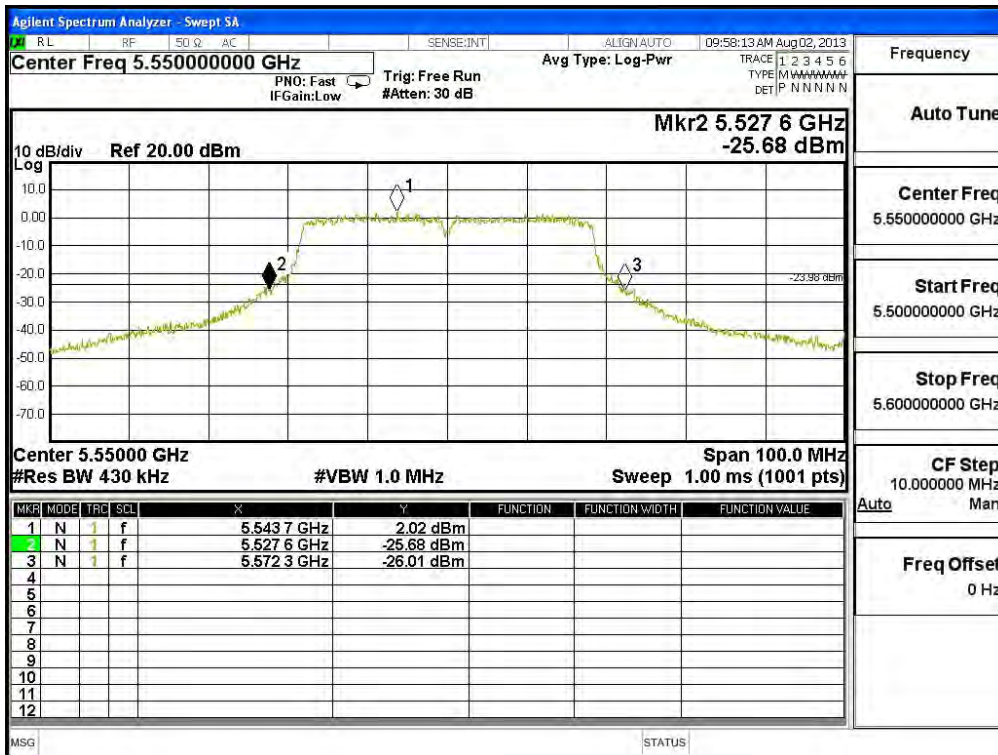

Channel 134 – Chain A

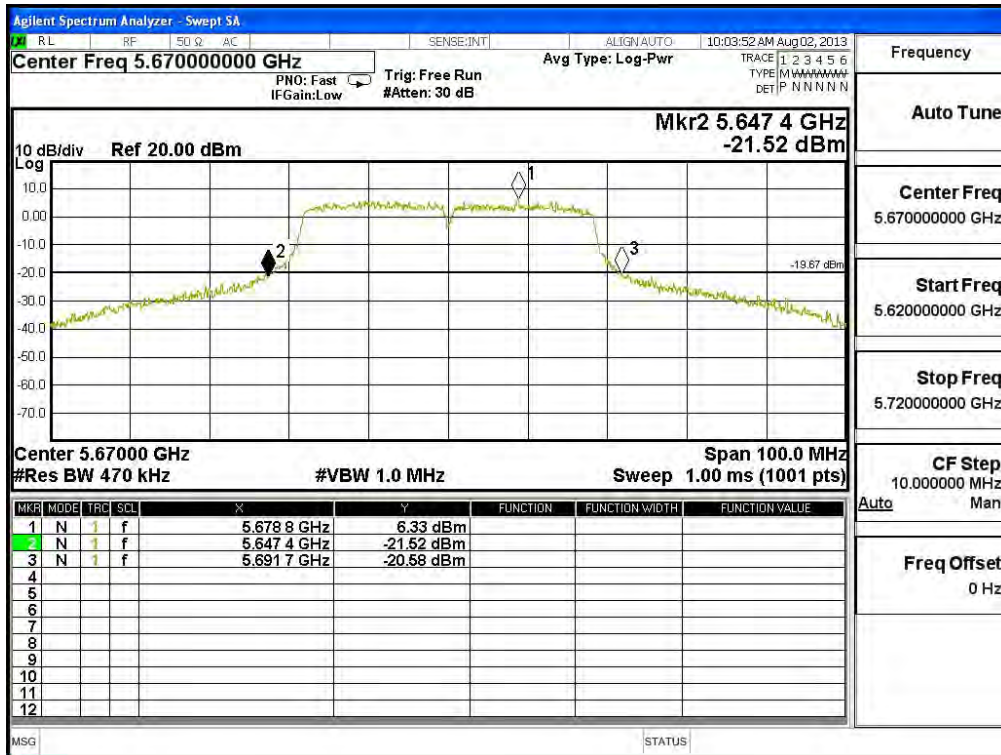

Channel 54 – Chain B

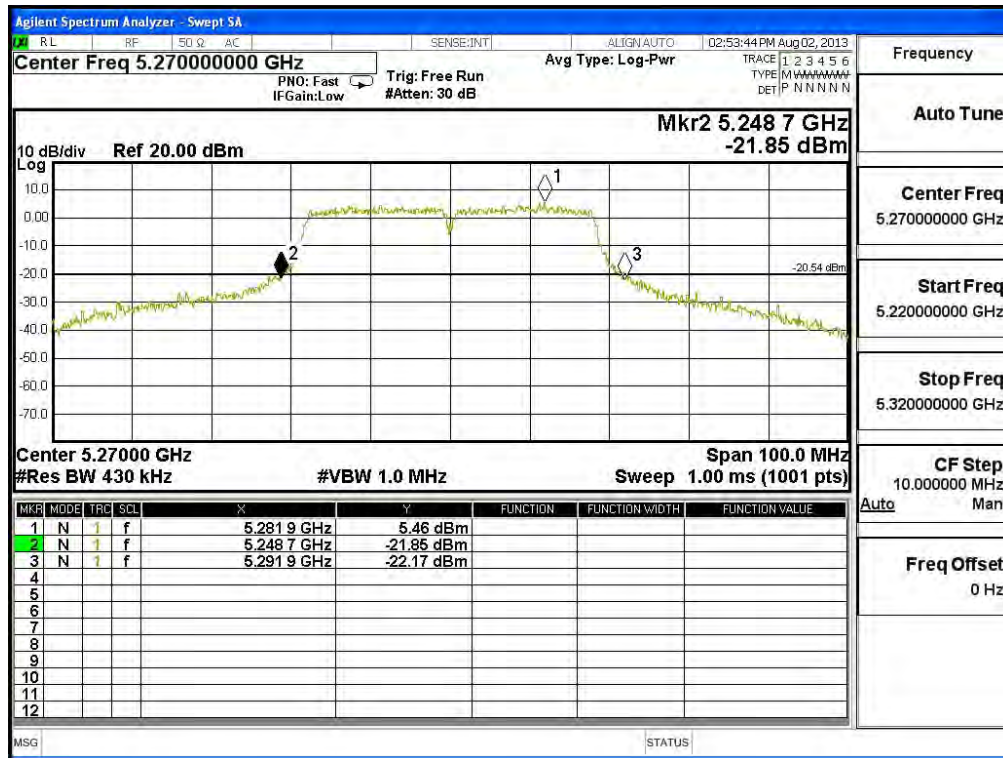

Channel 62 – Chain B

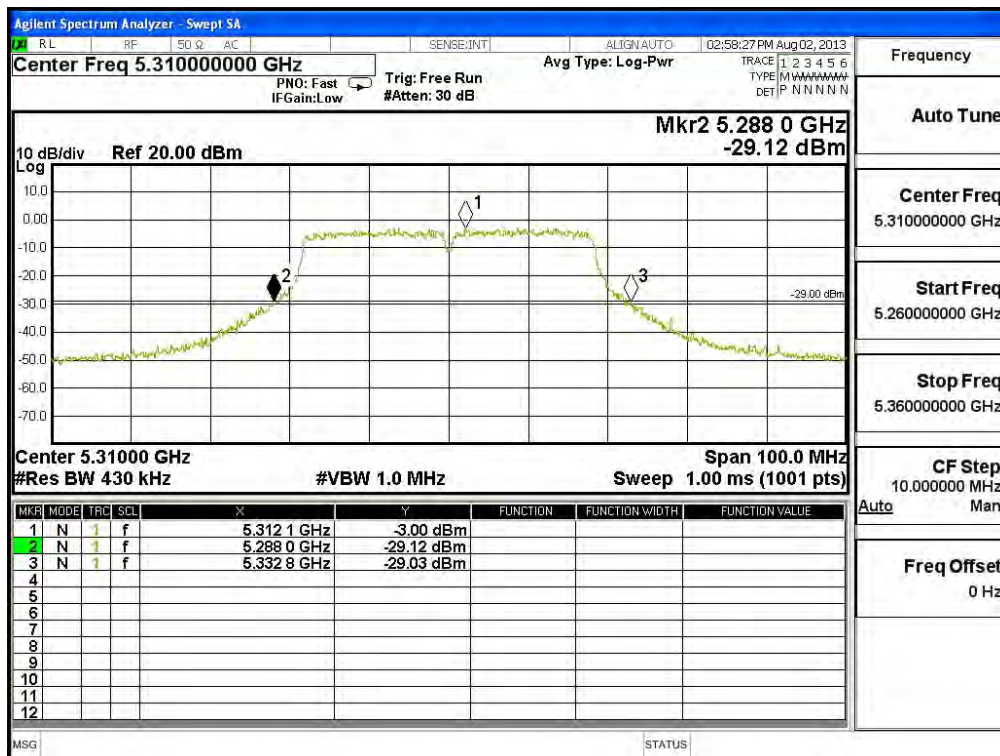

Channel 102 – Chain B

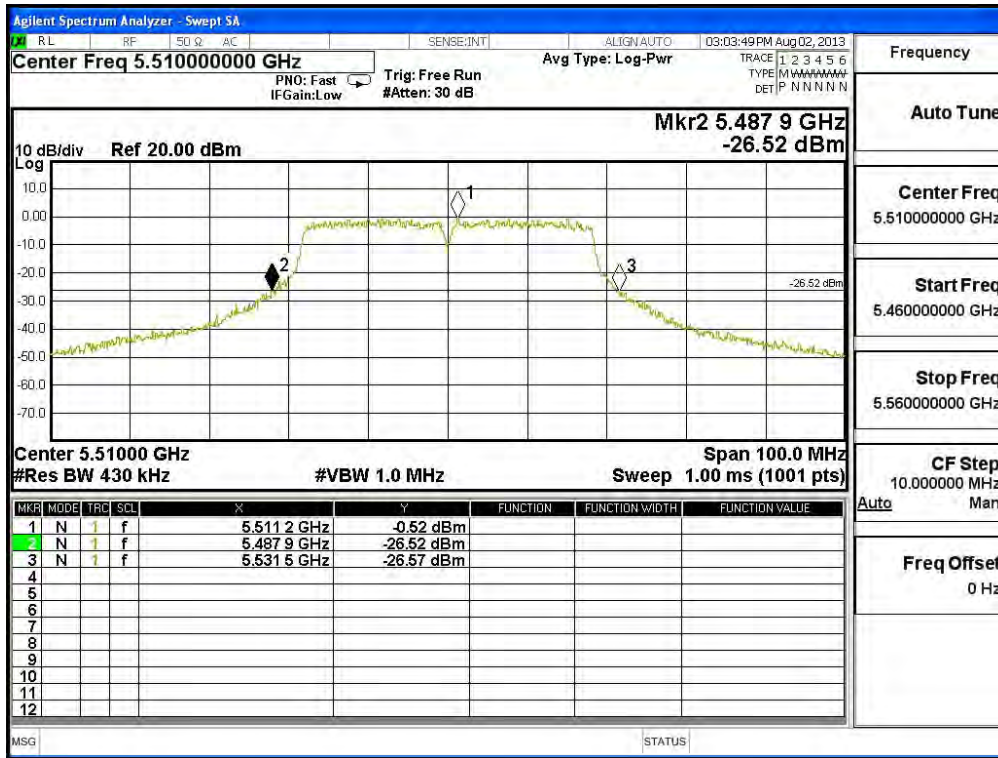

Channel 110 – Chain B

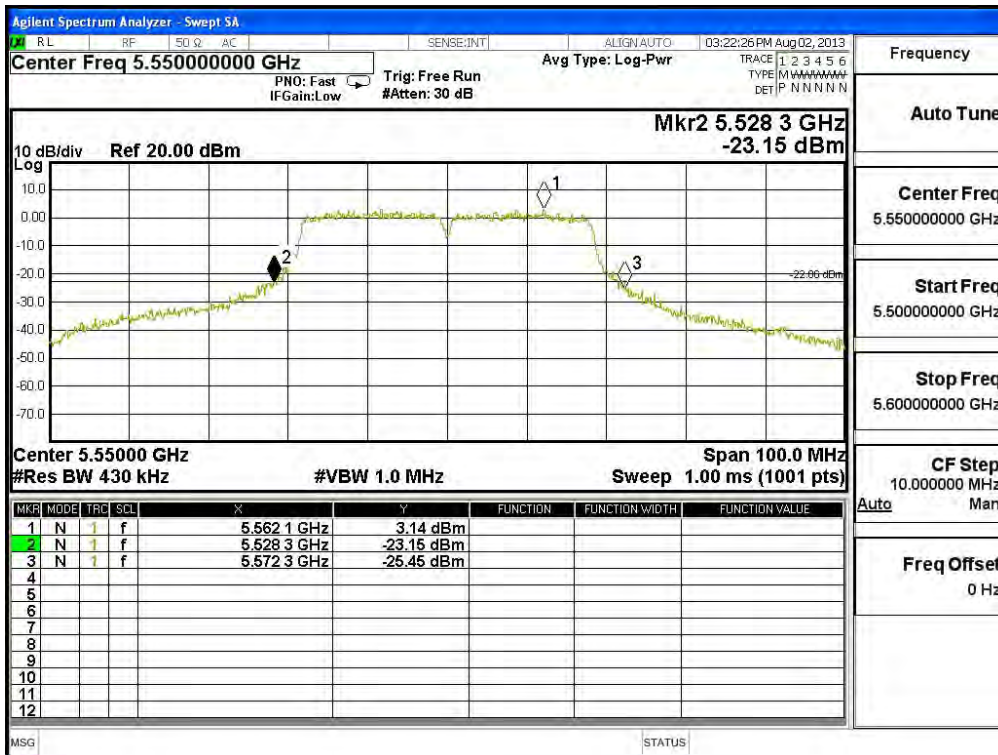

Channel 134 – Chain B

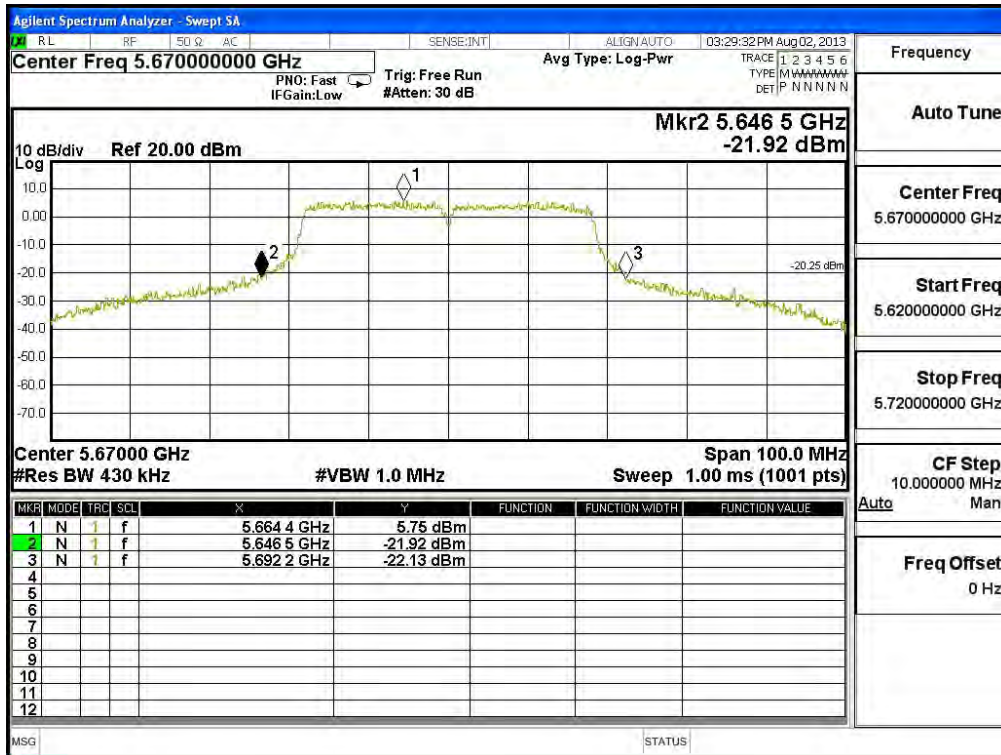

Product : SpectraGuard® Access Point / Sensor
 Test Item : Maximum conducted output power
 Test Site : No.3 OATS
 Test Mode : Mode 4: Transmit (802.11a-6Mbps)(PIFA Antenna)

CHAIN A

Cable loss=1dB		Maximum conducted output power								
Channel No.	Frequency (MHz)	Data Rate (Mbps)								Required Limit
		6	9	12	18	24	36	48	54	
		Measurement Level (dBm)								
52	5260	19.31	--	--	--	--	--	--	--	<24dBm
60	5300	19.81	19.70	19.66	19.57	19.49	19.42	19.34	19.27	<24dBm
64	5320	17.75	--	--	--	--	--	--	--	<24dBm
100	5500	17.79	--	--	--	--	--	--	--	<24dBm
116	5580	18.43	18.29	18.14	17.99	17.85	17.71	17.56	17.42	<24dBm
140	5700	19.56	--	--	--	--	--	--	--	<24dBm

Note: 1.Maximum conducted output power Value =Reading value on average power meter + cable loss

CHAIN B

Cable loss=1dB		Maximum conducted output power								
Channel No.	Frequency (MHz)	Data Rate (Mbps)								Required Limit
		6	9	12	18	24	36	48	54	
		Measurement Level (dBm)								
52	5260	19.48	--	--	--	--	--	--	--	<24dBm
60	5300	19.92	19.88	19.74	19.67	19.58	19.49	19.40	19.31	<24dBm
64	5320	18.84	--	--	--	--	--	--	--	<24dBm
100	5500	19.57	--	--	--	--	--	--	--	<24dBm
116	5580	18.36	18.21	18.14	18.02	17.91	17.80	17.69	17.58	<24dBm
140	5700	19.96	--	--	--	--	--	--	--	<24dBm

Note: 1.Maximum conducted output power Value =Reading value on average power meter + cable loss

Maximum conducted output power Measurement:

(CHAIN A+ B)

Channel Number	Frequency (MHz)	26dB Bandwidth (MHz)	Chain A Power (dBm)	Chain B Power (dBm)	Output Power (dBm)	Output Power Limit	
						(dBm)	dBm+10log(BW)
52	5260	38.000	19.31	19.48	22.41	24	26.80
60	5300	31.800	19.81	19.92	22.88	24	26.02
64	5320	25.500	17.75	18.84	21.34	24	25.07
100	5500	25.600	17.79	19.57	21.78	24	25.08
116	5580	29.950	18.43	18.36	21.41	24	25.76
140	5700	36.200	19.56	19.96	22.77	24	26.59

Note:

1. Power Output Value =Reading value on average power meter + cable loss
2. Output Power (dBm) = 10LOG (Chain A Power (mW)+ Chain B Power (mW))
3. 26 dB Bandwidth is the bandwidth of chain A or chain B whichever is less bandwidth, output power limitation is more stringent.

26dBc Occupied Bandwidth:

Channel 52: CHAIN A



Channel 60: CHAIN A

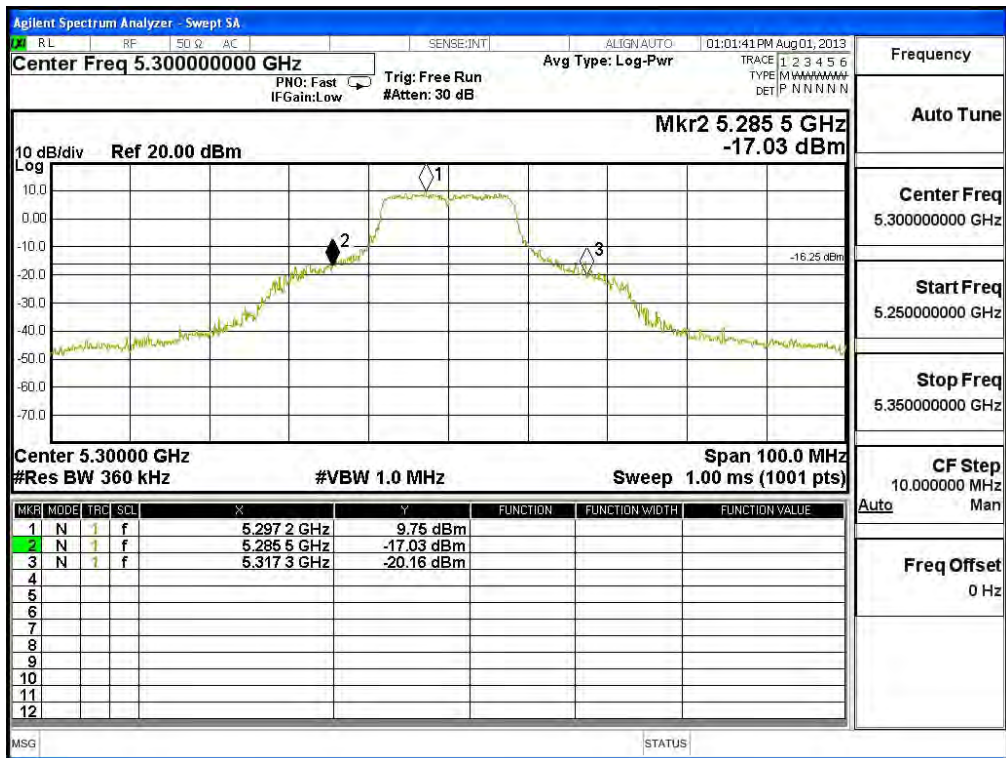

Channel 64: CHAIN A

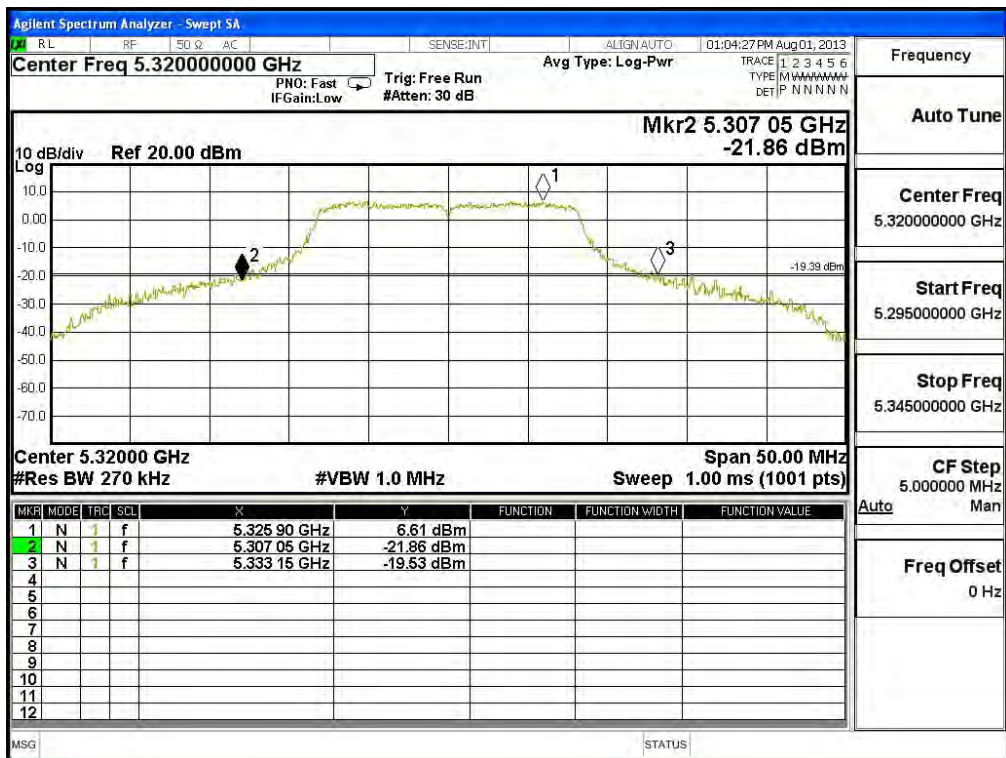

Channel 100: CHAIN A

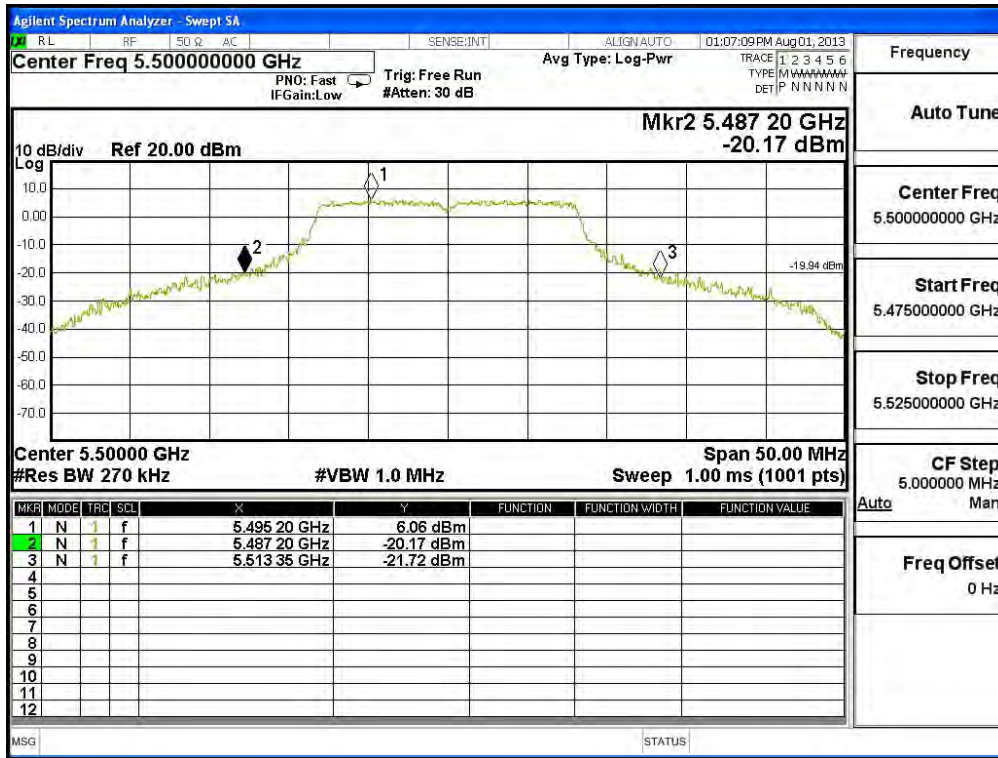

Channel 120: CHAIN A

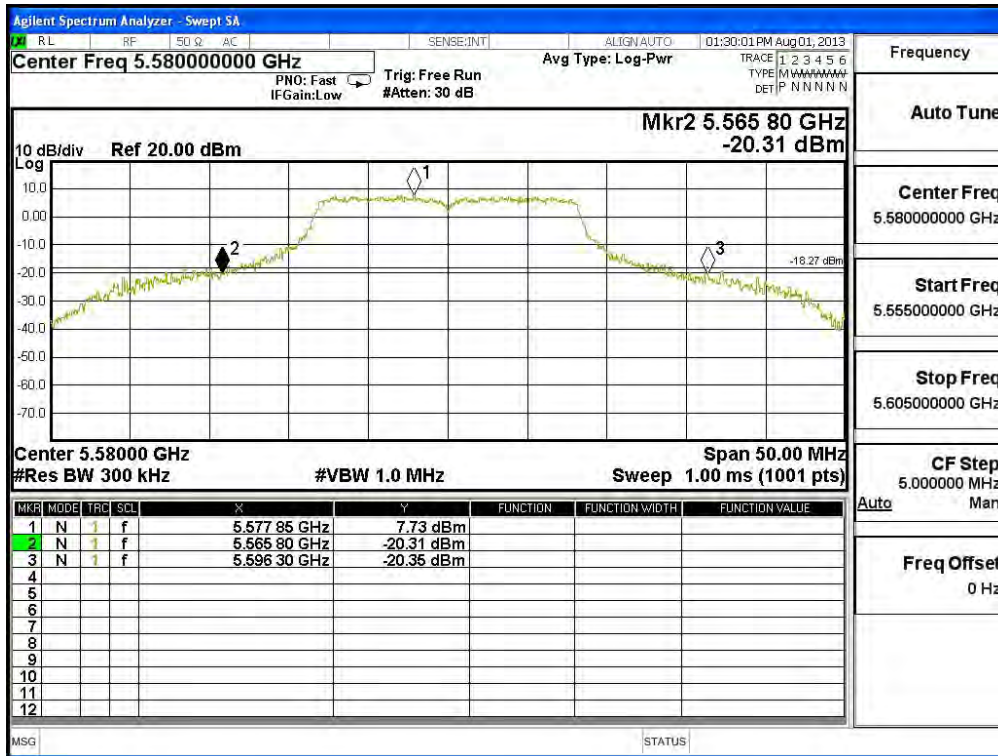

Channel 140: CHAIN A

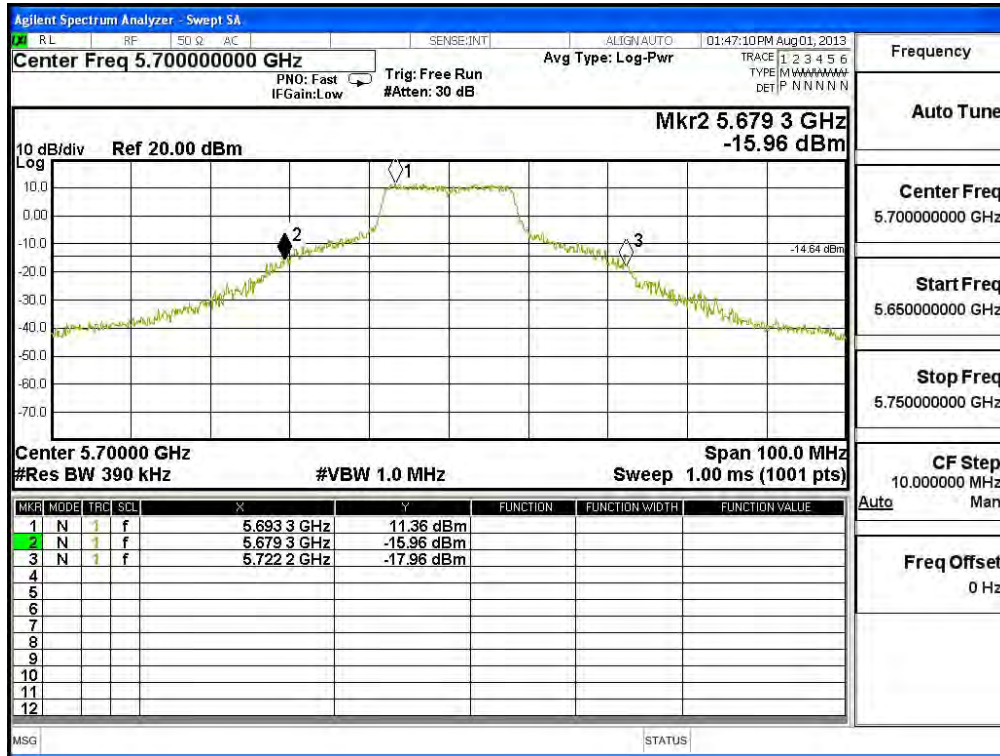

**26dBc Occupied Bandwidth:
Channel 52: CHAIN B**

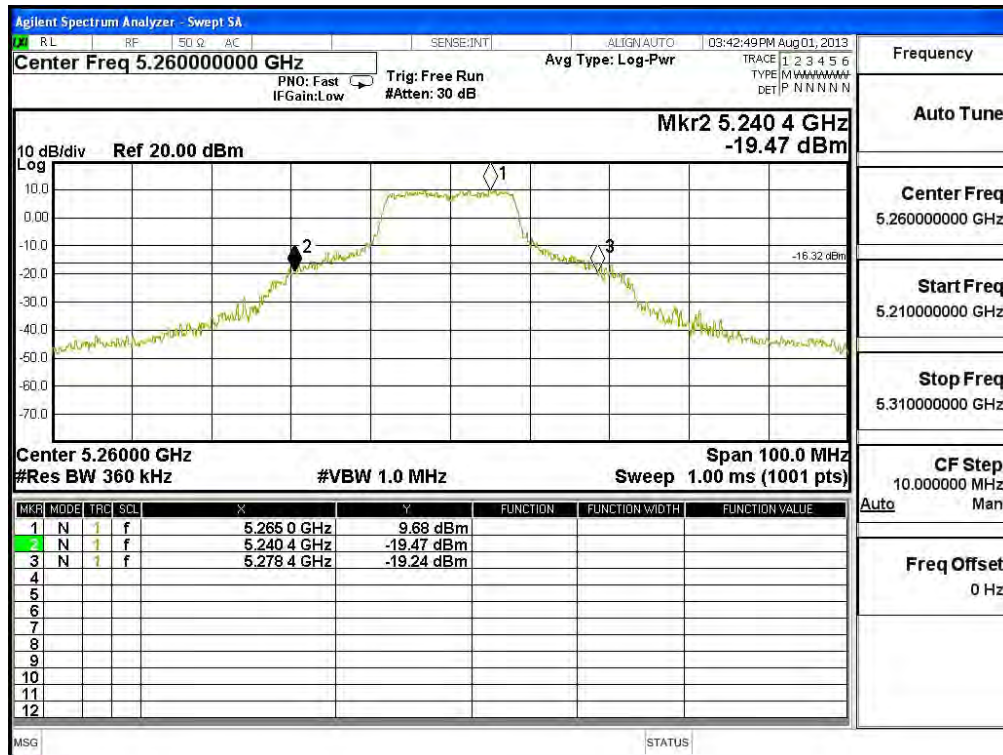

Channel 60: CHAIN B

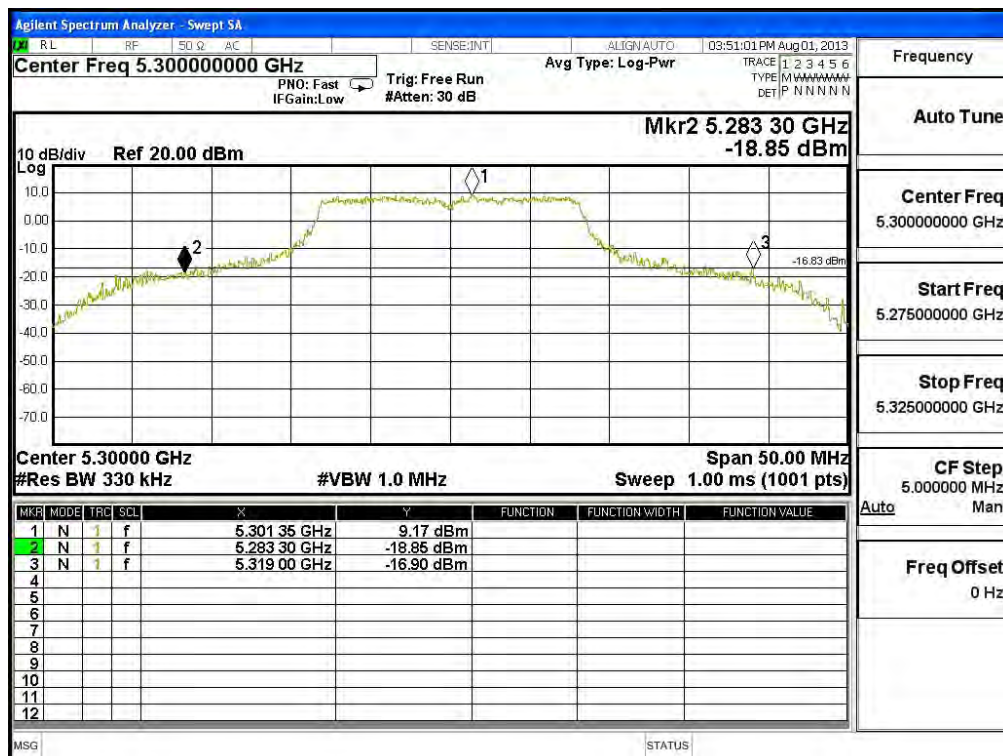

Channel 64: CHAIN B

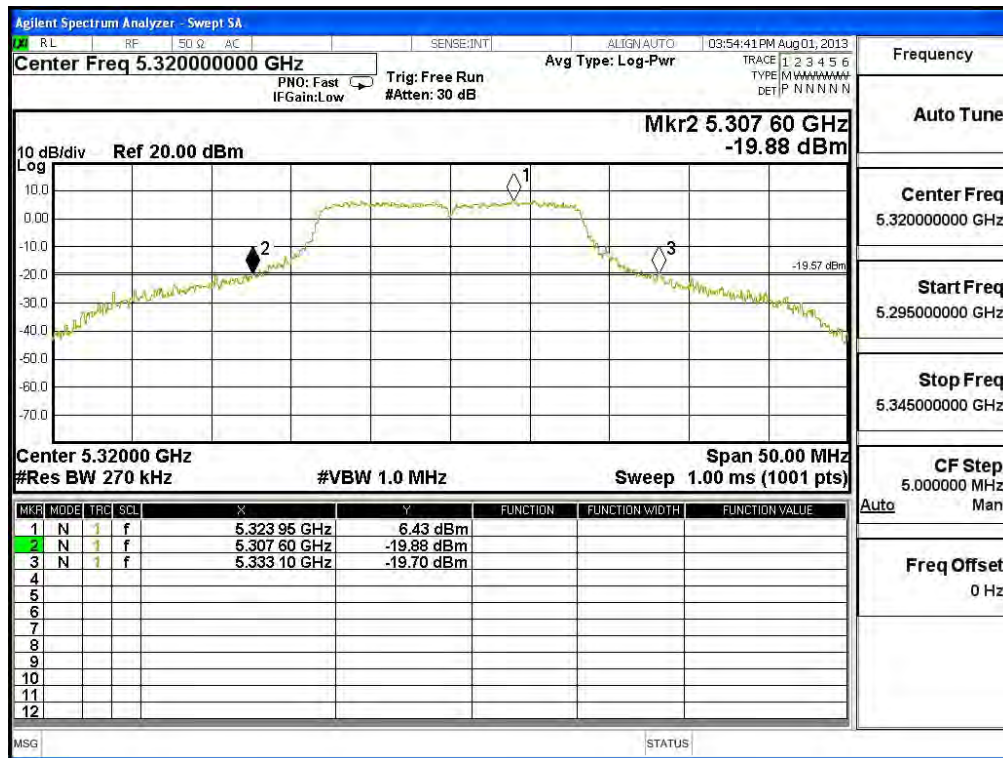

Channel 100: CHAIN B

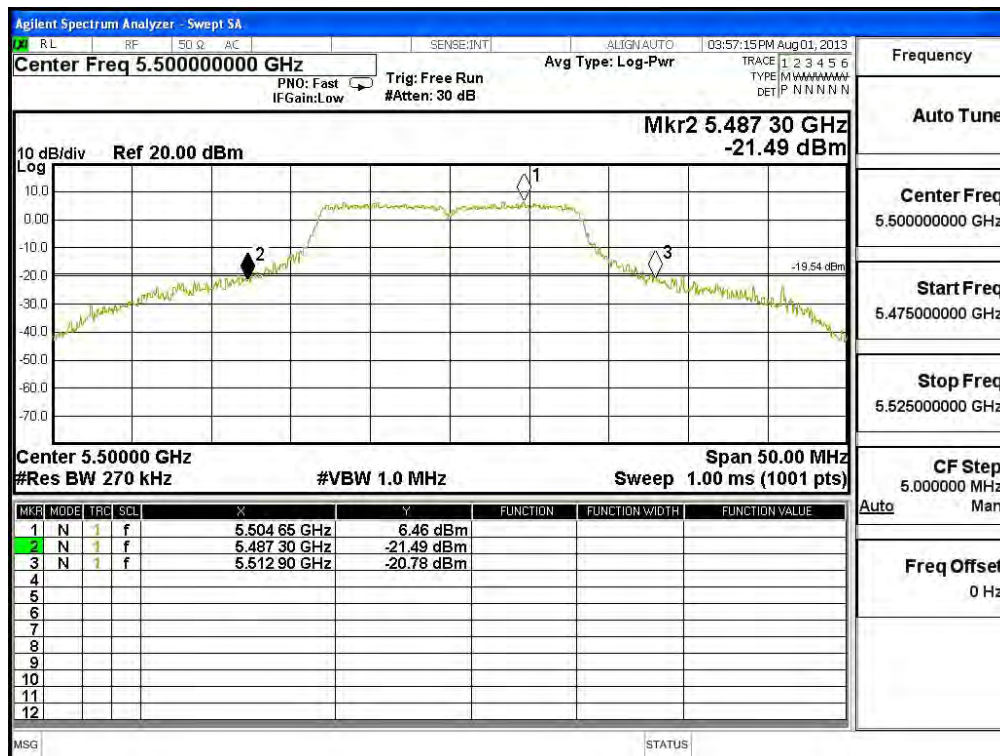

Channel 120: CHAIN B

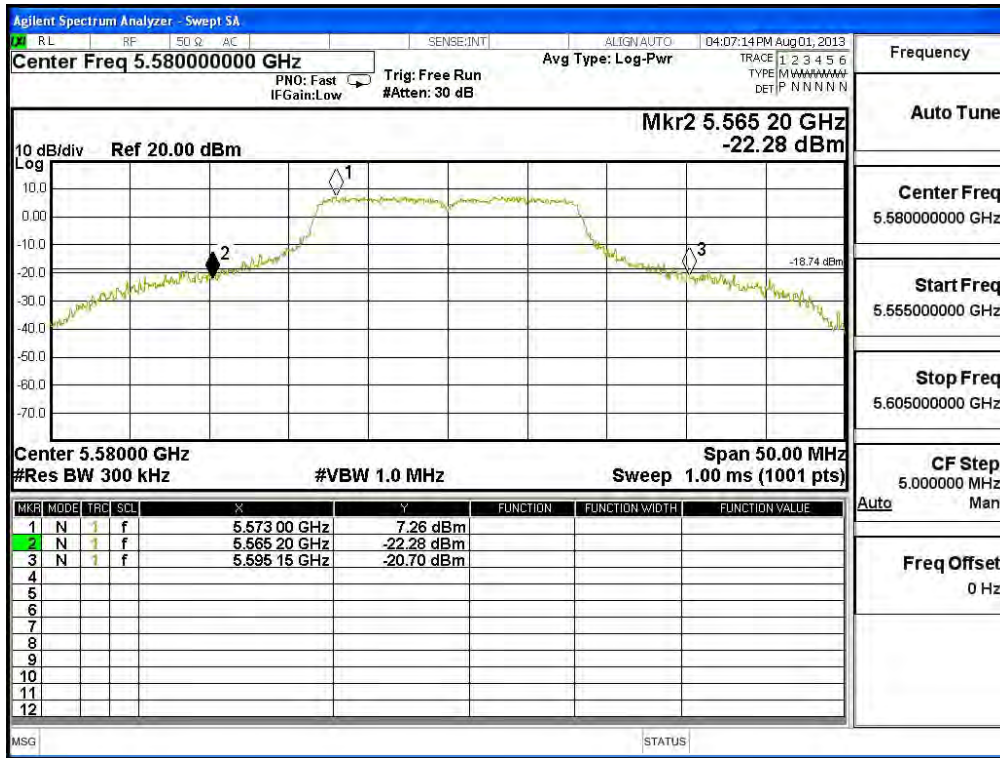

Channel 140: CHAIN B

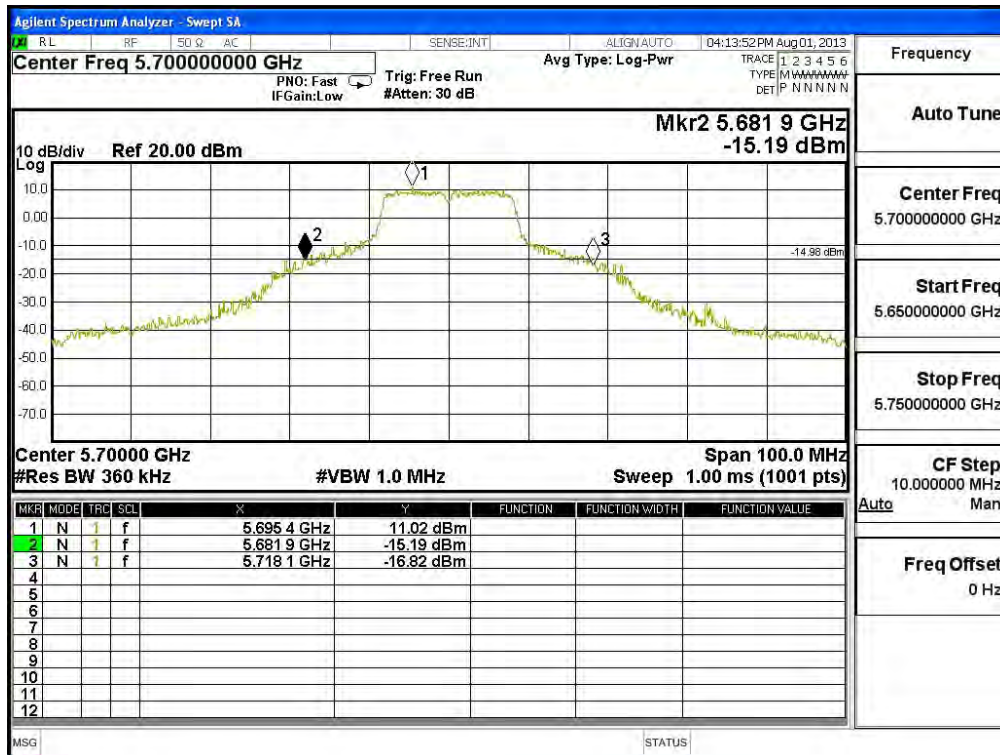

Product : SpectraGuard® Access Point / Sensor
 Test Item : Maximum conducted output power
 Test Site : No.3 OATS
 Test Mode : Mode 5: Transmit (802.11n-20BW 14.4Mbps)(PIFA Antenna)

CHAIN A

Cable loss=1dB		Maximum conducted output power								
Channel No.	Frequency (MHz)	Data Rate (Mbps)								Required Limit
		14.4	28.9	43.3	57.8	86.7	115.6	130	144.4	
		Measurement Level (dBm)								
52	5260	19.41	--	--	--	--	--	--	--	<24dBm
60	5300	19.38	19.22	19.10	18.95	19.81	18.67	18.53	18.39	<24dBm
64	5320	17.74	--	--	--	--	--	--	--	<24dBm
100	5500	19.39	--	--	--	--	--	--	--	<24dBm
116	5580	16.68	16.54	16.38	16.23	16.08	15.93	15.78	15.63	<24dBm
140	5700	19.81	--	--	--	--	--	--	--	<24dBm

Note: 1.Maximum conducted output power Value =Reading value on average power meter + cable loss

CHAIN B

Cable loss=1dB		Maximum conducted output power								
Channel No.	Frequency (MHz)	Data Rate (Mbps)								Required Limit
		14.4	28.9	43.3	57.8	86.7	115.6	130	144.4	
		Measurement Level (dBm)								
52	5260	19.88	--	--	--	--	--	--	--	<24dBm
60	5300	19.92	19.78	19.55	19.38	19.19	19.01	18.82	18.64	<24dBm
64	5320	19.23	--	--	--	--	--	--	--	<24dBm
100	5500	19.45	--	--	--	--	--	--	--	<24dBm
116	5580	17.01	16.87	16.64	16.47	16.28	16.1	15.91	15.73	<24dBm
140	5700	19.47	--	--	--	--	--	--	--	<24dBm

Note: 1.Maximum conducted output power Value =Reading value on average power meter + cable loss

Maximum conducted output power Measurement:
(CHAIN A+ B)

Channel Number	Frequency (MHz)	26dB Bandwidth (MHz)	Chain A Power (dBm)	Chain B Power (dBm)	Output Power (dBm)	Output Power Limit	
						(dBm)	dBm+10log(BW)
52	5260	39.100	19.41	19.88	22.66	24	26.92
60	5300	37.800	19.81	19.92	22.88	24	26.77
64	5320	24.950	17.74	19.23	21.56	24	24.97
100	5500	27.750	19.39	19.45	22.43	24	25.43
116	5580	23.000	16.68	17.01	19.86	24	24.62
140	5700	33.400	19.81	19.47	22.65	24	26.24

Note:

1. Power Output Value = Reading value on average power meter + cable loss
2. Output Power (dBm) = 10LOG (Chain A Power (mW)+ Chain B Power (mW))
3. 26 dB Bandwidth is the bandwidth of chain A or chain B whichever is less bandwidth, output power limitation is more stringent.

26dBc Occupied Bandwidth: Channel 52 -Chain A

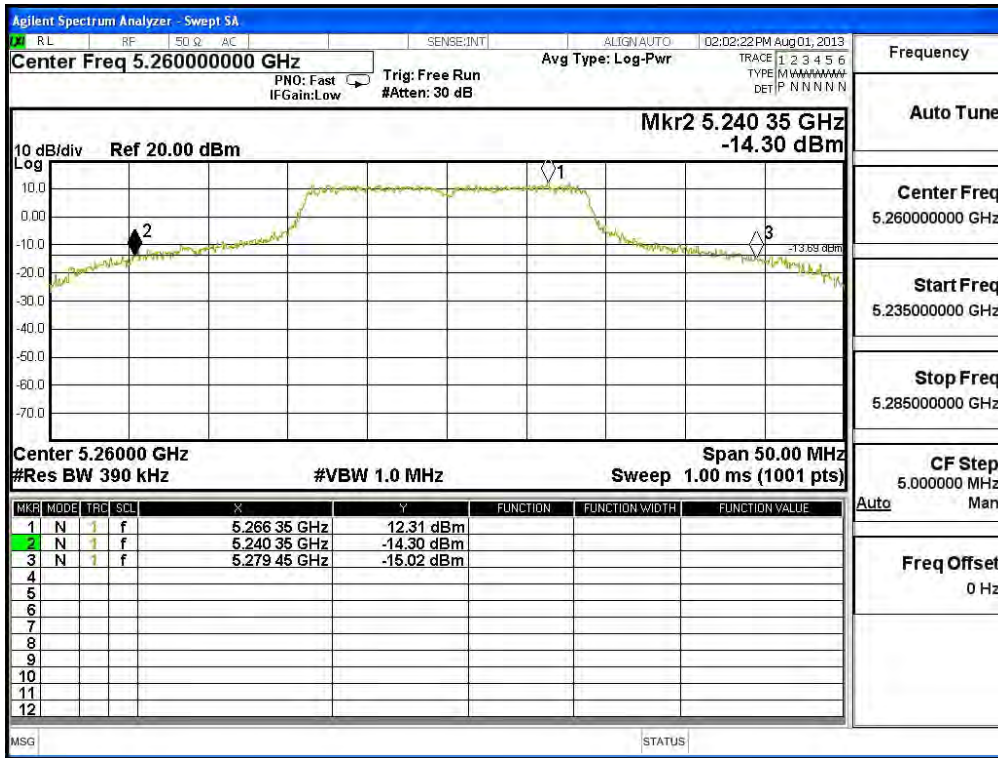

Channel 60 -Chain A

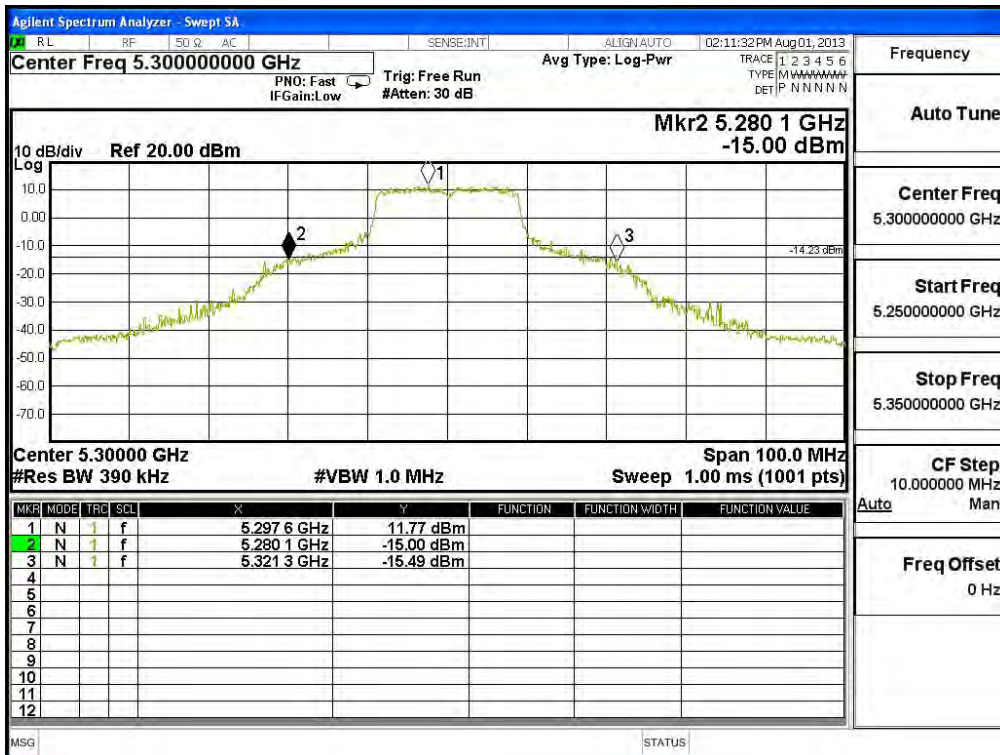

Channel 120 -Chain A

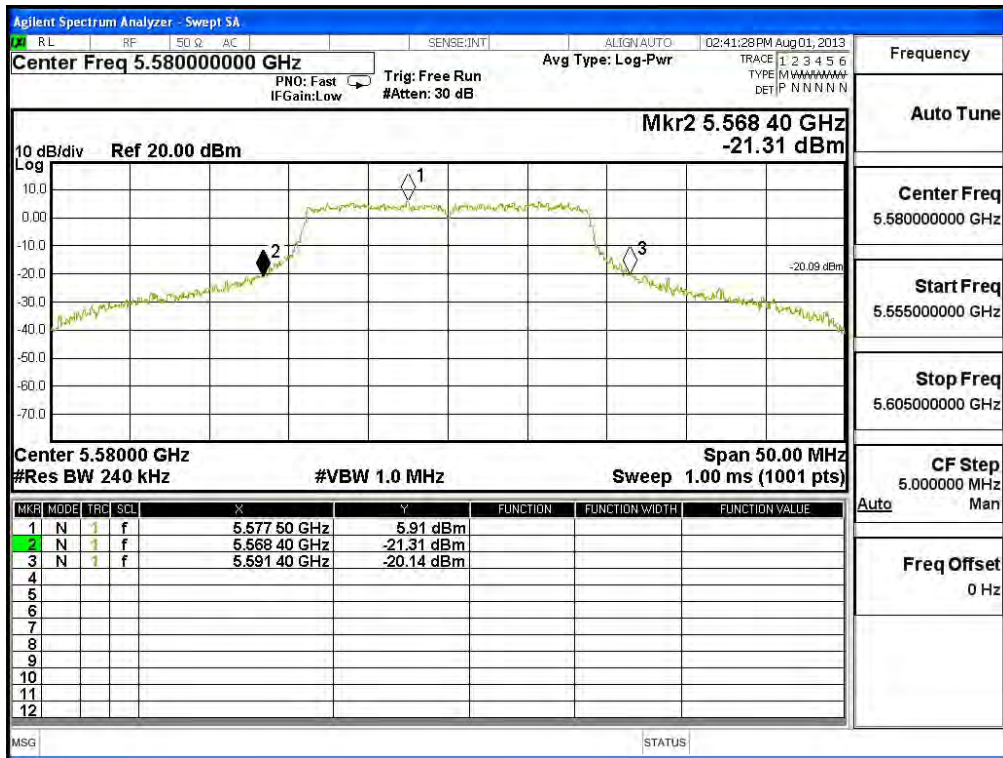

Channel 140 -Chain A

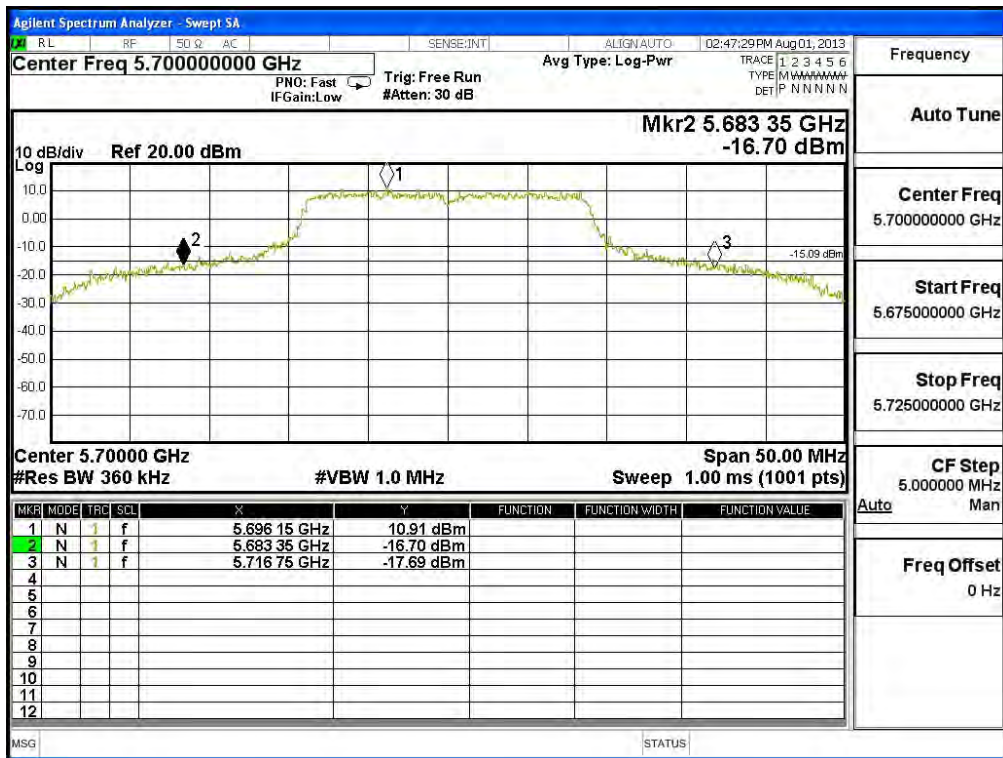

Channel 52 -Chain B

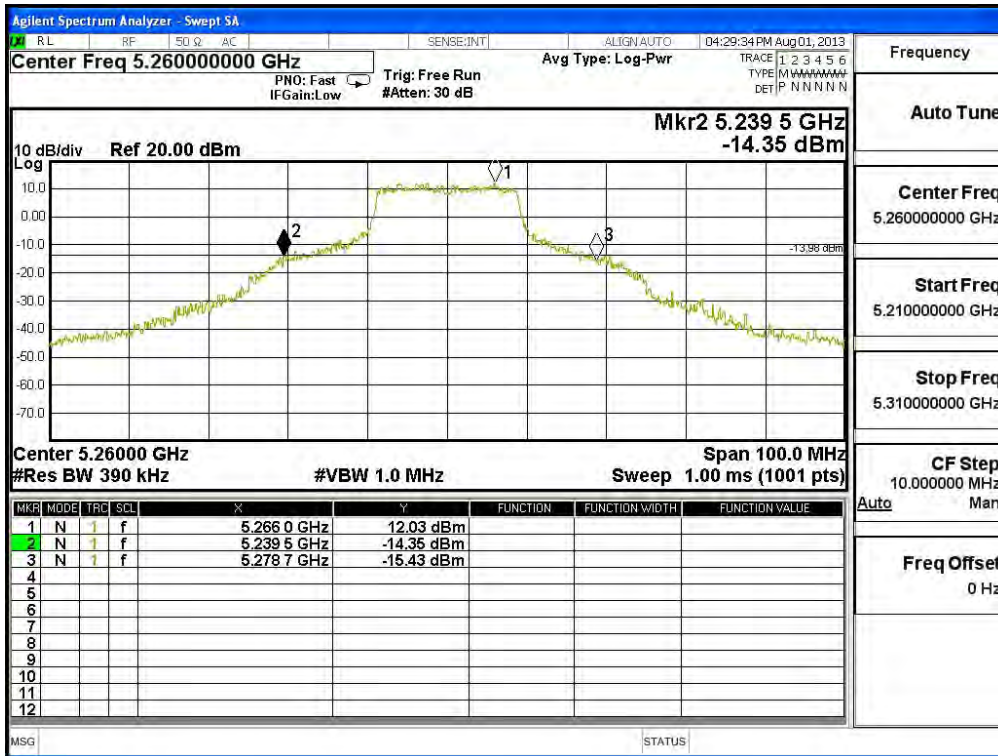

Channel 60 -Chain B

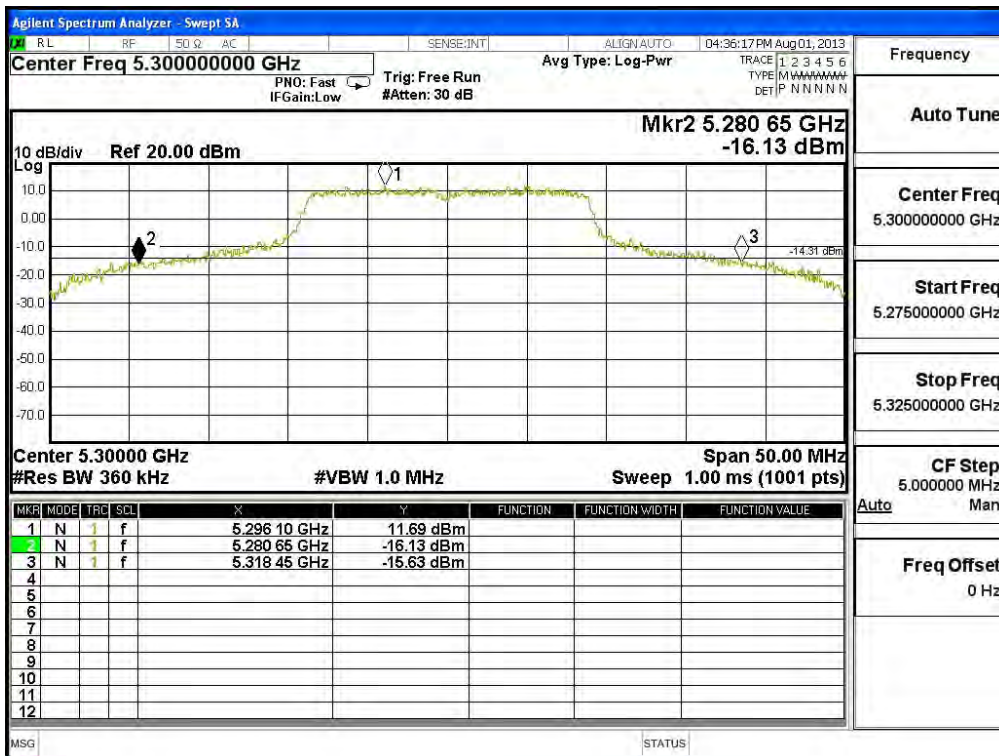

Channel 64 -Chain B

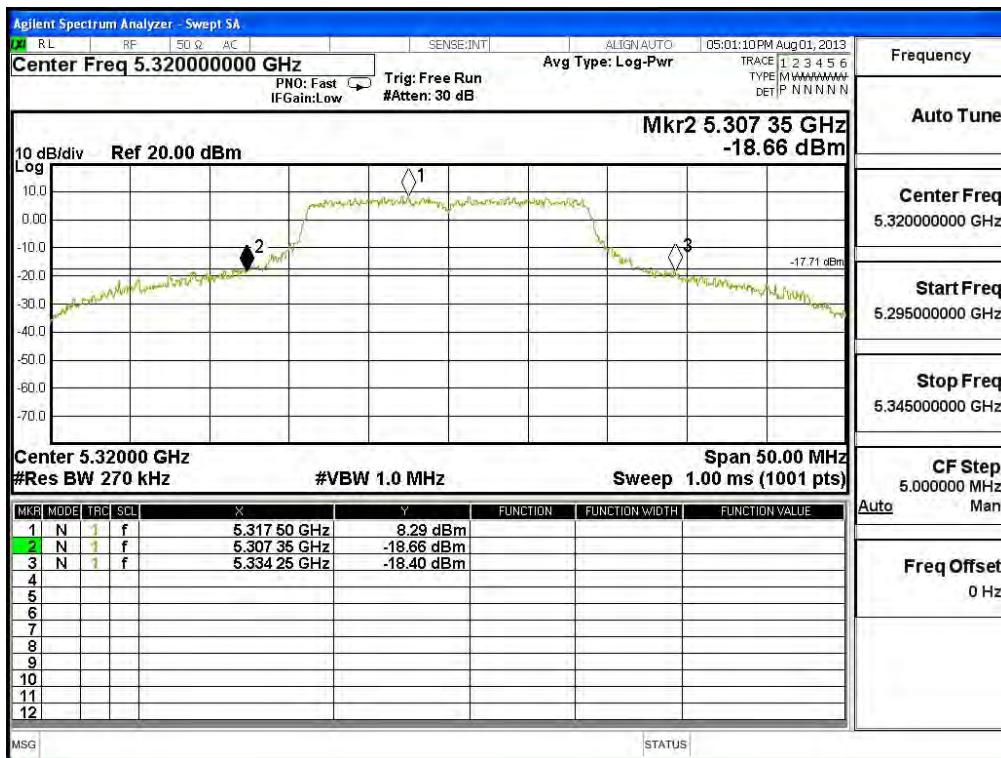

Channel 100 -Chain B

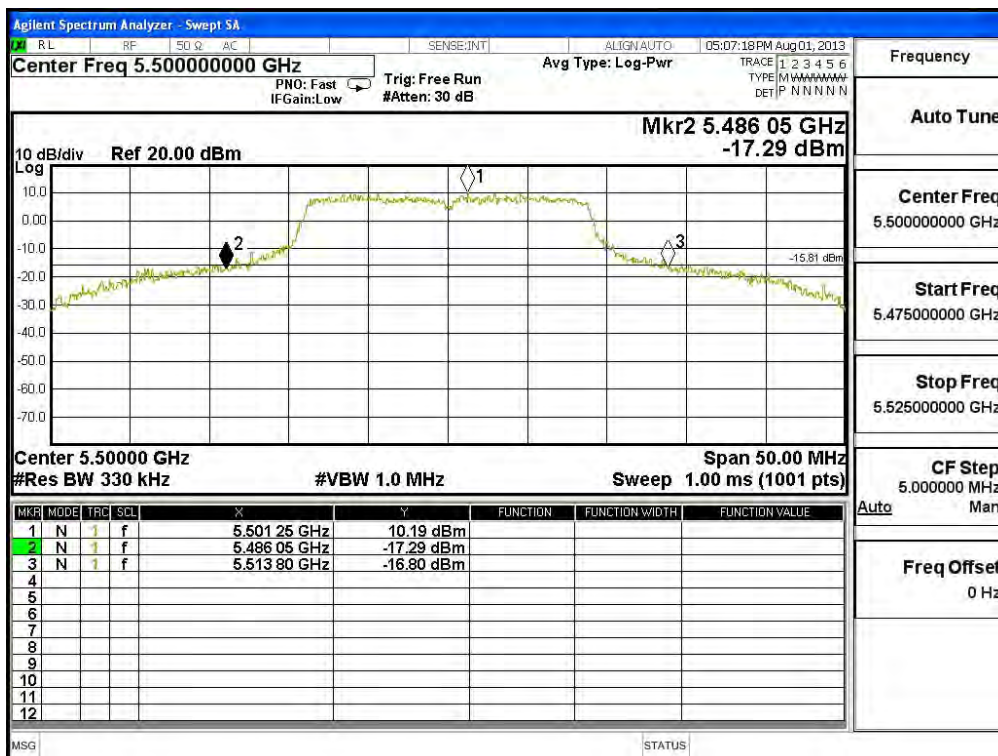

Channel 120 -Chain B

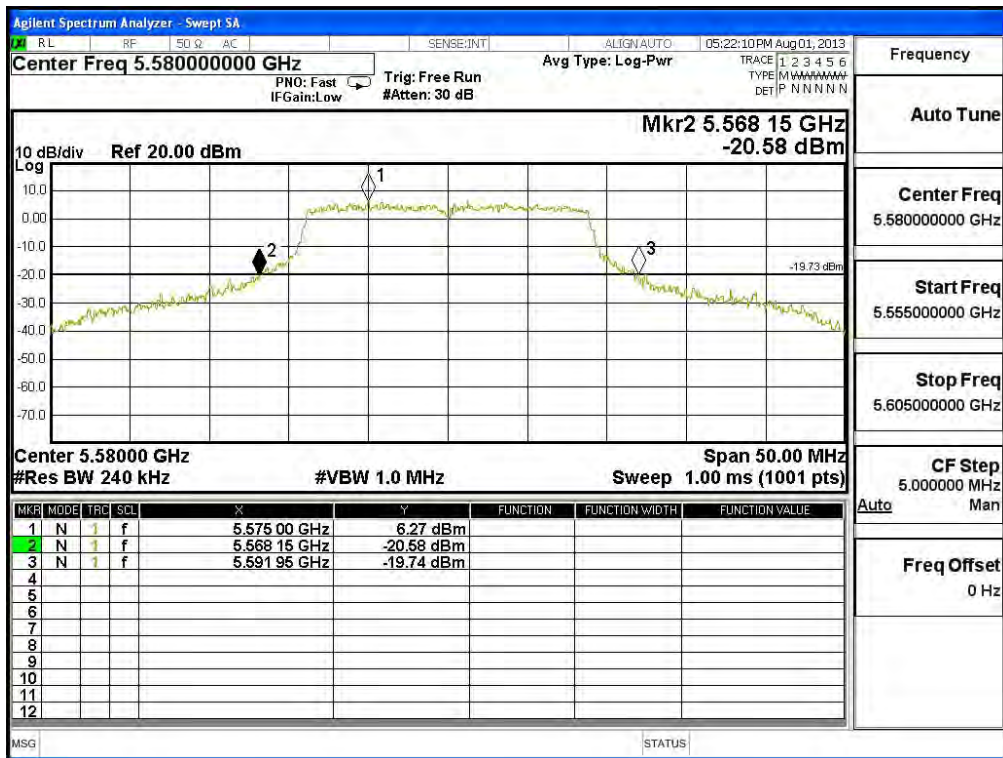

Channel 140 -Chain B

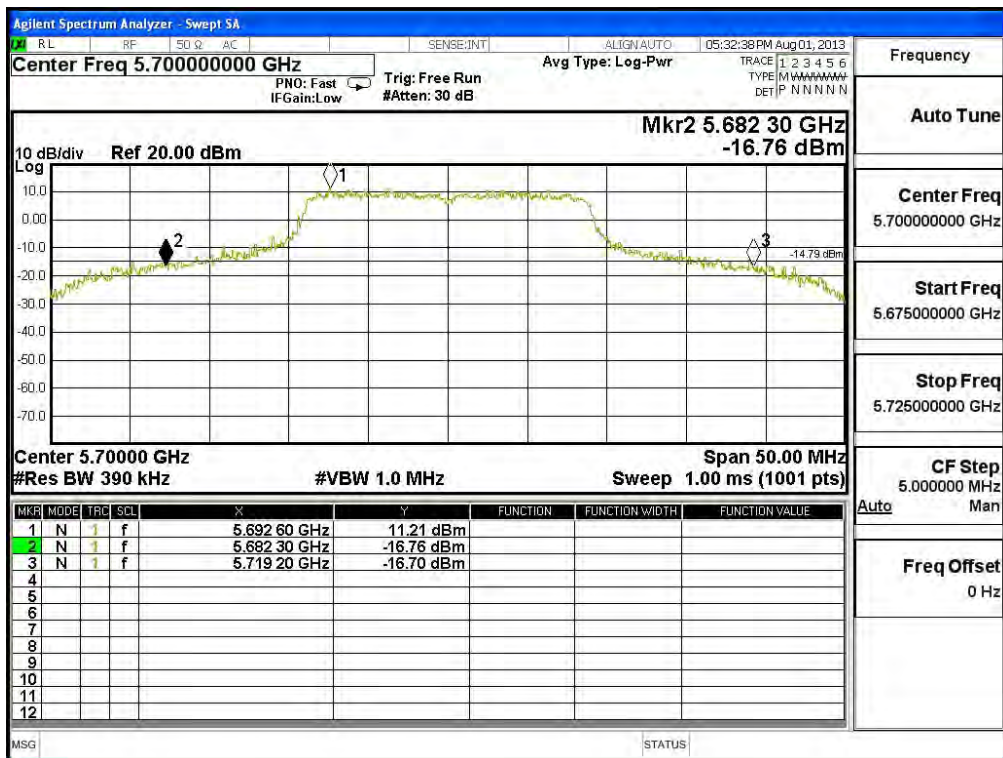

Product : SpectraGuard® Access Point / Sensor
 Test Item : Maximum conducted output power
 Test Site : No.3 OATS
 Test Mode : Mode 6: Transmit (802.11n-40BW 30Mbps)(PIFA Antenna)

CHAIN A

Cable loss=1dB		Maximum conducted output power								
Channel No.	Frequency (MHz)	Data Rate (Mbps)								Required Limit
		30	60	90	120	180	240	270	300	
		Measurement Level (dBm)								
54	5270	19.62	--	--	--	--	--	--	--	<24dBm
62	5310	14.29	14.18	14.09	13.99	13.89	13.79	13.69	13.59	<24dBm
102	5510	14.60	--	--	--	--	--	--	--	<24dBm
110	5550	14.62	14.47	14.32	14.17	14.02	13.87	13.72	13.57	<24dBm
134	5670	13.40	--	--	--	--	--	--	--	<24dBm

Note: 1.Maximum conducted output power Value =Reading value on average power meter + cable loss

CHAIN B

Cable loss=1dB		Maximum conducted output power								
Channel No.	Frequency (MHz)	Data Rate (Mbps)								Required Limit
		30	60	90	120	180	240	270	300	
		Measurement Level (dBm)								
54	5270	19.72	--	--	--	--	--	--	--	<24dBm
62	5310	15.8	15.67	15.54	15.41	15.28	15.15	15.02	14.89	<24dBm
102	5510	16.73	--	--	--	--	--	--	--	<24dBm
110	5550	16.46	16.32	16.19	16.05	15.92	15.78	15.65	15.51	<24dBm
134	5670	13.85	--	--	--	--	--	--	--	<24dBm

Note: 1.Maximum conducted output power Value =Reading value on average power meter + cable loss

Maximum conducted output power Measurement:
(CHAIN A+ B)

Channel Number	Frequency (MHz)	26dB Bandwidth (MHz)	Chain A Power (dBm)	Chain B Power (dBm)	Output Power (dBm)	Output Power Limit	
						(dBm)	dBm+10log(BW)
54	5270	77.400	19.62	19.72	22.68	24	29.89
62	5310	44.900	14.29	15.80	18.12	24	27.52
102	5510	44.700	14.60	16.73	18.80	24	27.50
110	5550	44.900	14.62	16.46	18.65	24	27.52
134	5670	44.800	13.40	13.85	16.64	24	27.51

Note:

1. Power Output Value =Reading value on average power meter + cable loss
2. Output Power (dBm) = 10LOG (Chain A Power (mW)+ Chain B Power (mW))
3. 26 dB Bandwidth is the bandwidth of chain A or chain B whichever is less bandwidth, output power limitation is more stringent.

**26dBc Occupied Bandwidth:
Channel 54 – Chain A**

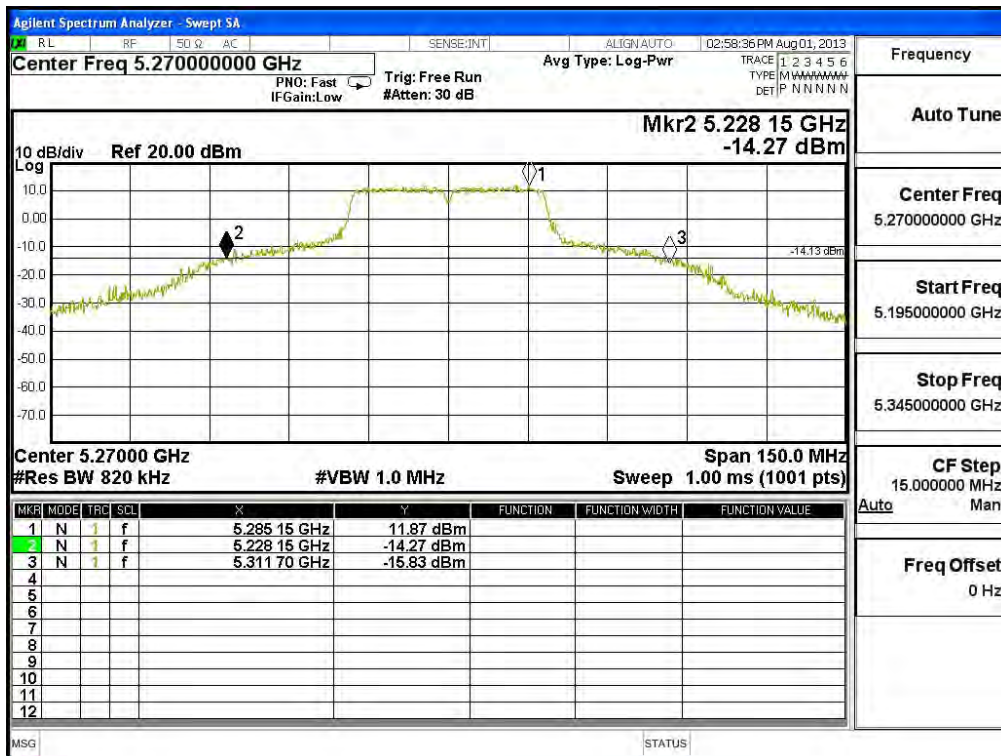

Channel 62 – Chain A

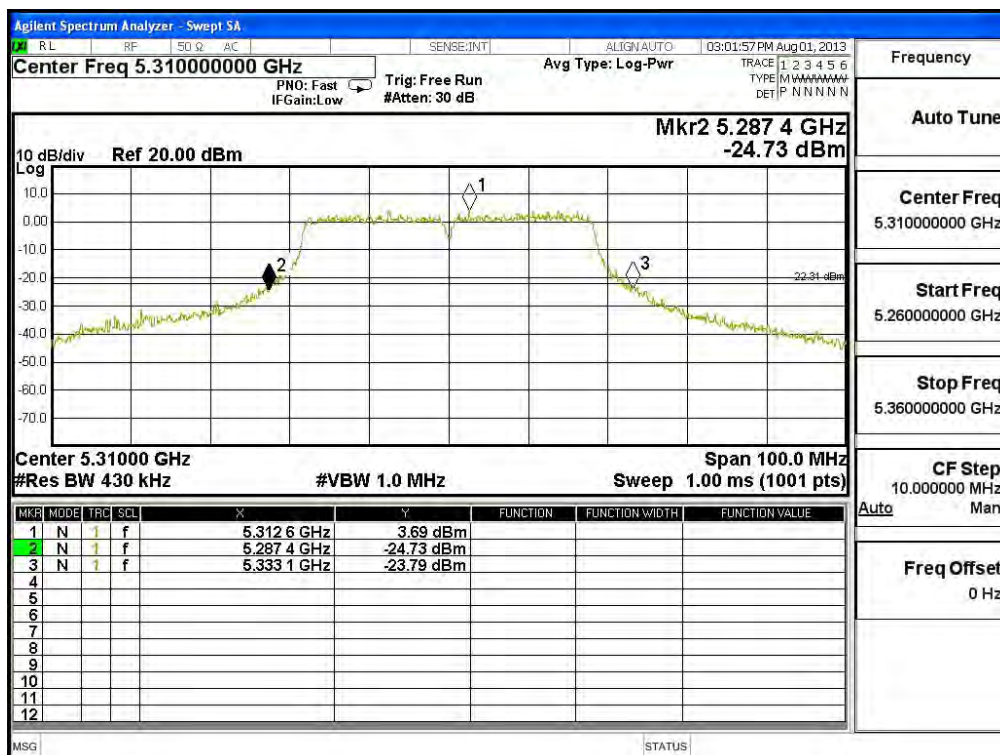

Channel 102 – Chain A

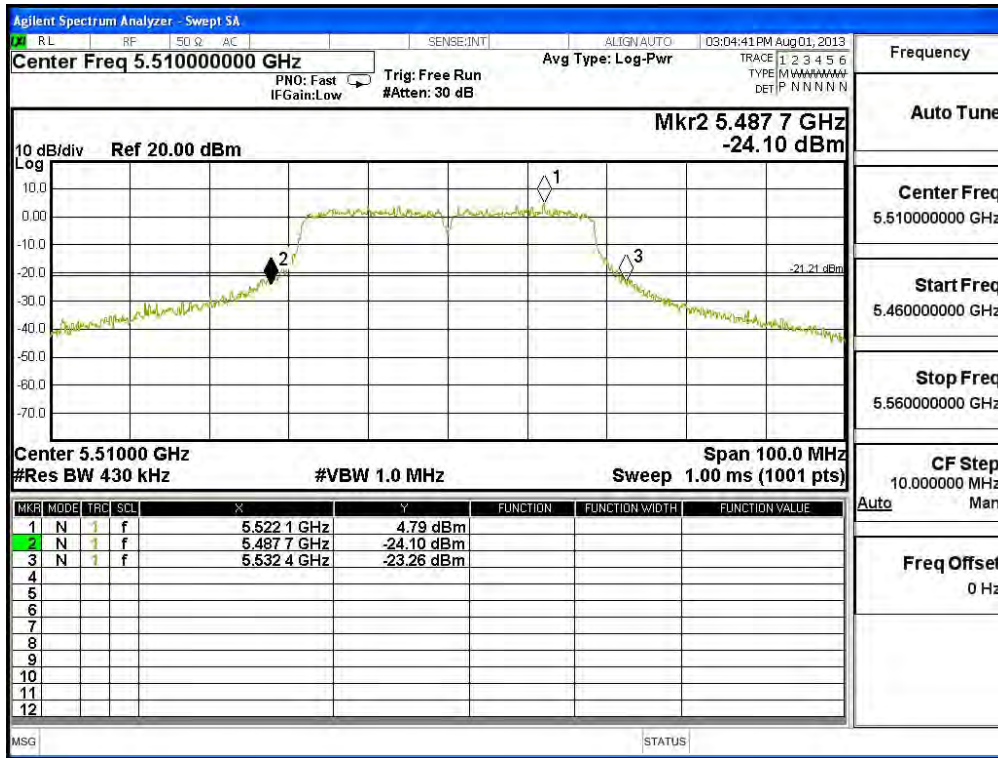

Channel 110 – Chain A

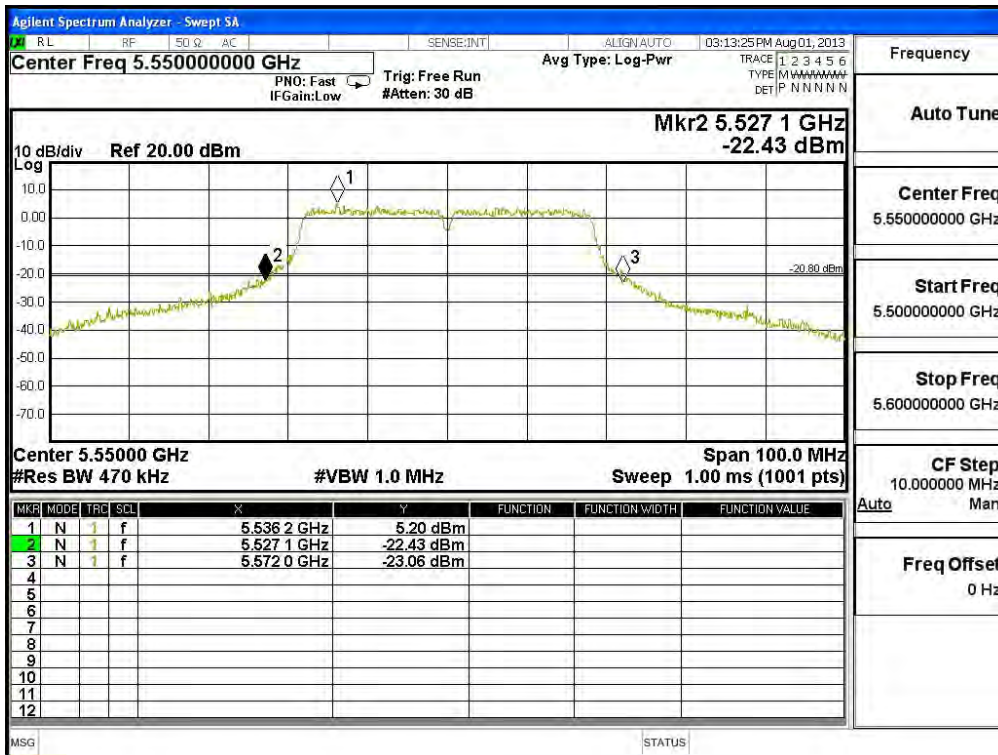

Channel 134 – Chain A

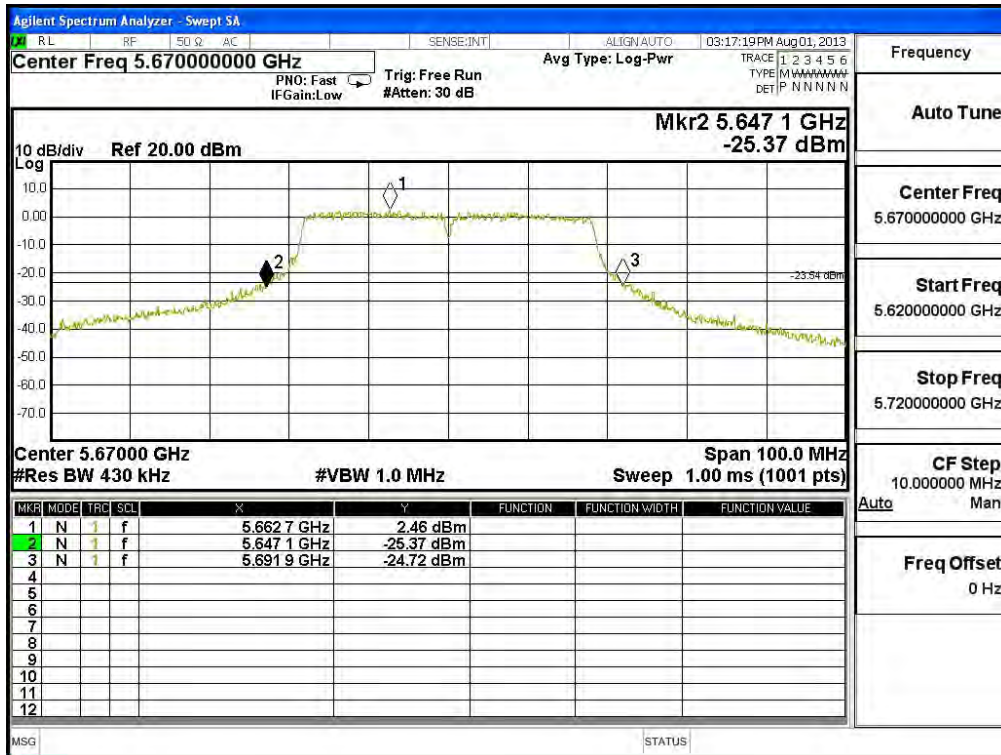

Channel 54 – Chain B

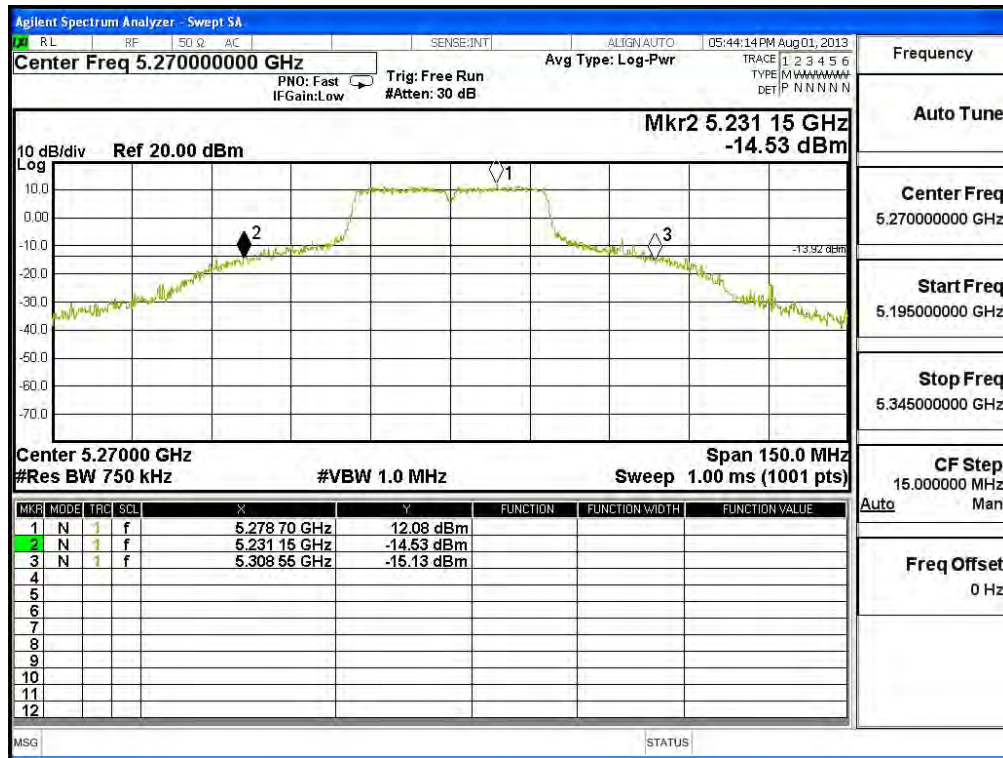

Channel 62 – Chain B

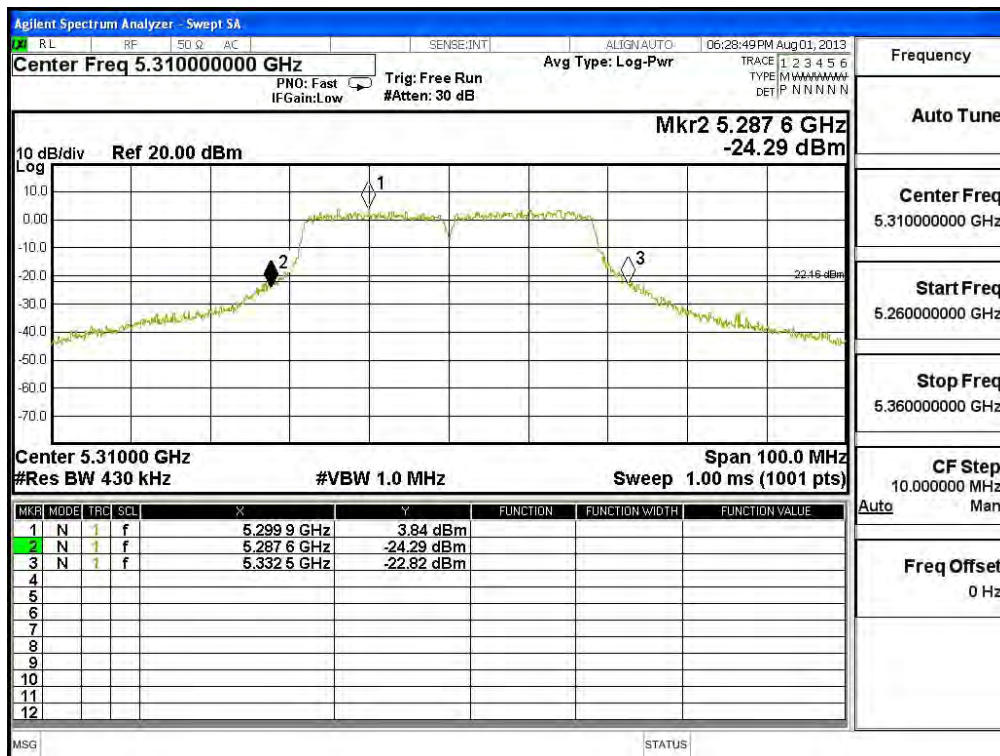

Channel 102 – Chain B

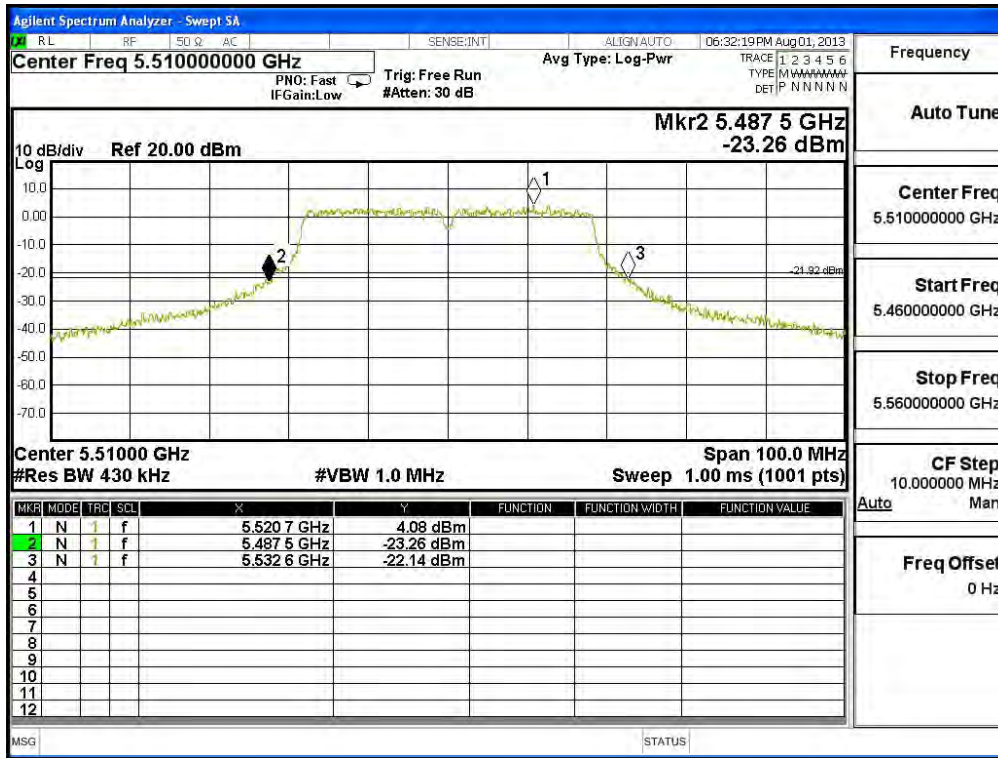

Channel 110 – Chain B

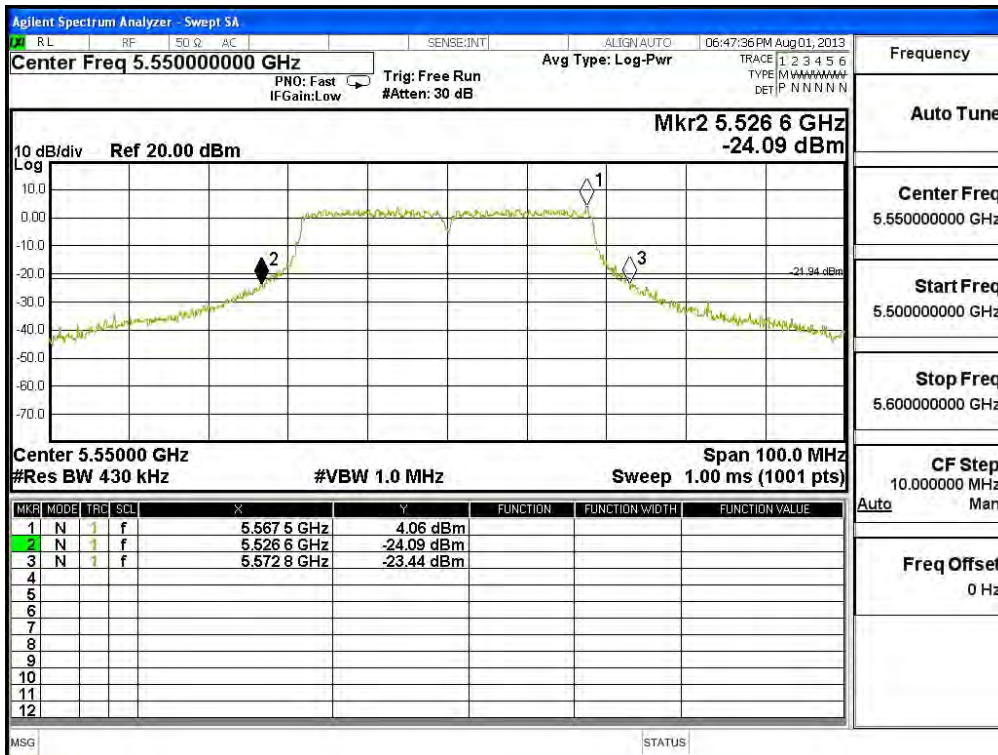

Channel 134 – Chain B

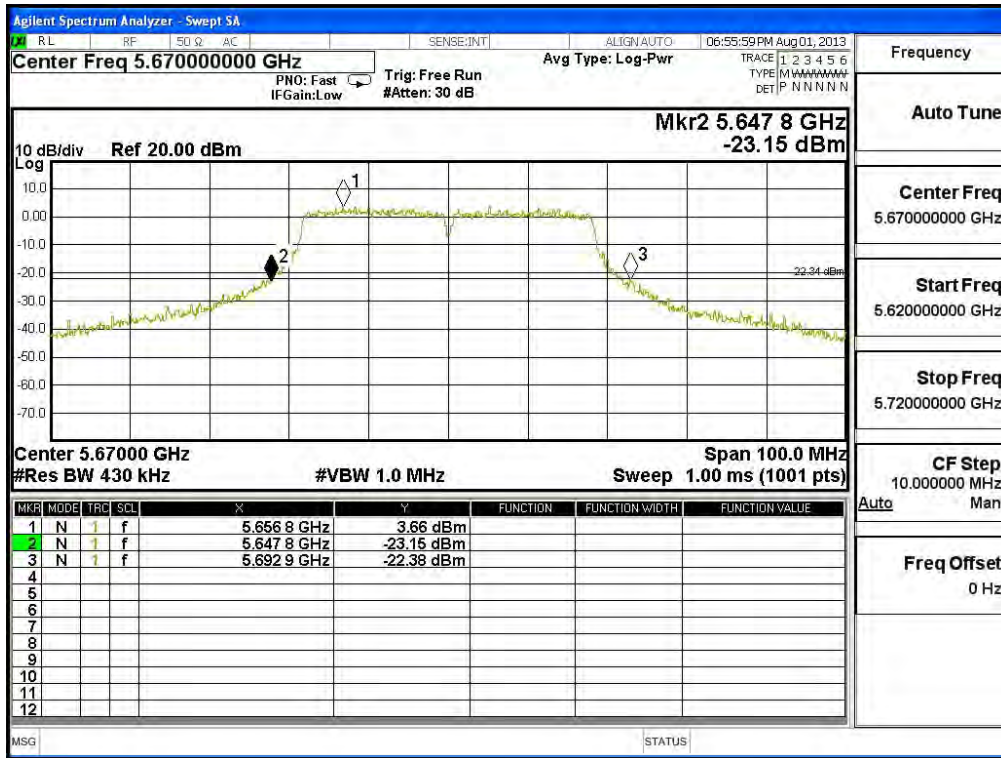

Frequency	
Auto Tune	
Center Freq	5.67000000 GHz
Start Freq	5.62000000 GHz
Stop Freq	5.72000000 GHz
CF Step	10.000000 MHz
Auto Man	
Freq Offset	0 Hz

4. Peak Power Spectral Density

4.1. Test Equipment

	Equipment	Manufacturer	Model No./Serial No.	Last Cal.
	Spectrum Analyzer	R&S	FSP40 / 100170	Jun, 2013
	Spectrum Analyzer	Agilent	E4407B / US39440758	Jun, 2013
X	Spectrum Analyzer	Agilent	N9010A / MY48030495	Apr, 2013

Note:

1. All equipments are calibrated with traceable calibrations. Each calibration is traceable to the national or international standards.
2. The test instruments marked with “X” are used to measure the final test results.

4.2. Test Setup

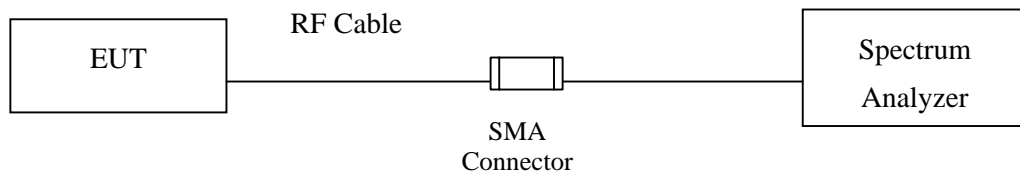

4.3. Limits

- For the band 5.15-5.25 GHz, the peak power spectral density shall not exceed 4 dBm in any 1-MHz band. If transmitting antenna of directional gain greater than 6 dBi are used, the peak power spectral density shall be reduced by the amount in dB that directional gain of the antenna exceeds 6 dBi.
- For the band 5.25-5.35 GHz, the peak power spectral density shall not exceed 11 dBm in any 1-MHz band. If transmitting antenna of directional gain greater than 6 dBi are used, the peak power spectral density shall be reduced by the amount in dB that directional gain of the antenna exceeds 6 dBi.
- For the band 5.725-5.825 GHz, the peak power spectral density shall not exceed 17 dBm in any 1-MHz band. If transmitting antenna of directional gain greater than 6 dBi are used, the peak power spectral density shall be reduced by the amount in dB that directional gain of the antenna exceeds 6 dBi.

4.4. Test Procedure

The EUT was setup to ANSI C63.10, 2009; tested to DTS test procedure of FCC KDB-789033 for compliance to FCC 47CFR Subpart E requirements.

The Peak Power Spectral Density using KDB 789033 section F) procedure, Create an average power spectrum for the EUT operating mode being tested by following the instructions in section E)2) for measuring maximum conducted output power using a spectrum analyzer.

SA-1 method is selected to run the test.

4.5. Uncertainty

± 1.27 dB

4.6. Test Result of Peak Power Spectral Density

Product : SpectraGuard® Access Point / Sensor
 Test Item : Peak Power Spectral Density
 Test Site : No.3 OATS
 Test Mode : Mode 1: Transmit (802.11a-6Mbps)(Dipole Antenna)

Channel Number	Frequency (MHz)	Chain	PPSD/MHz (dBm)	Total PSD/MHz (dBm) ₁	Required Limit (dBm)	Result
52	5260	A	4.980	7.990	<11	Pass
		B	3.840	6.850	<11	Pass
60	5300	A	3.520	6.530	<11	Pass
		B	3.110	6.120	<11	Pass
64	5320	A	2.380	5.390	<11	Pass
		B	2.390	5.400	<11	Pass
100	5500	A	1.520	4.530	<11	Pass
		B	1.660	4.670	<11	Pass
116	5580	A	4.860	7.870	<11	Pass
		B	4.120	7.130	<11	Pass
140	5700	A	4.660	7.670	<11	Pass
		B	3.820	6.830	<11	Pass

Note 1: The quantity $10 \cdot \log 2$ (two antennas) is added to the spectrum peak value according to document 662911 D01.

Channel 52: CHAIN A

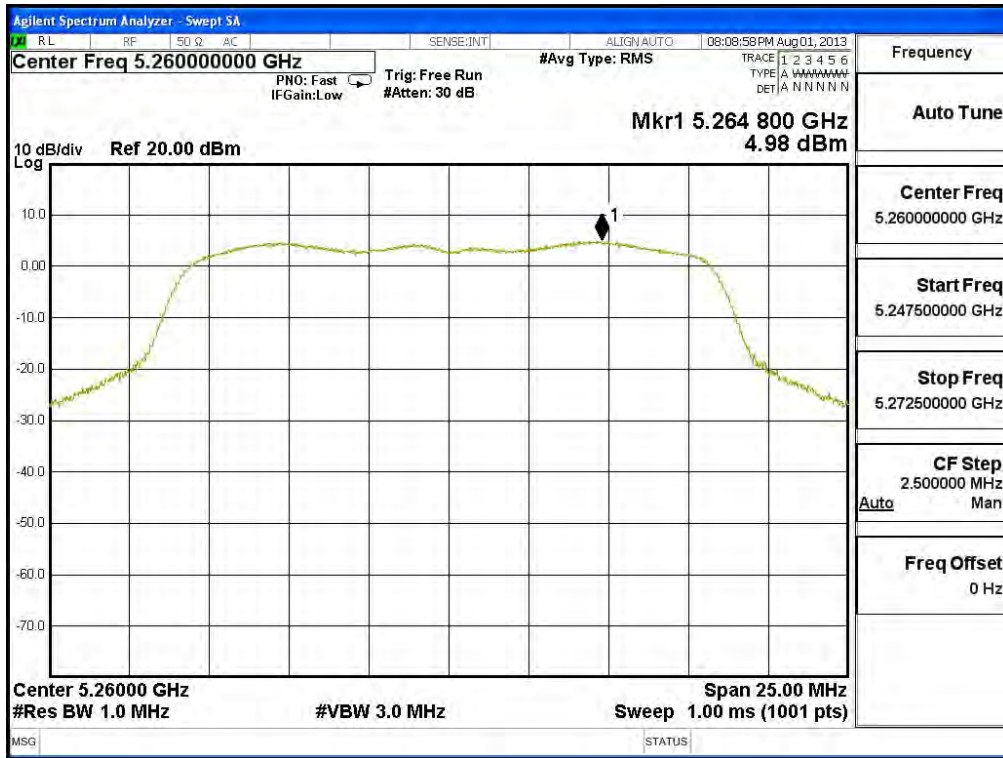

Channel 60: CHAIN A

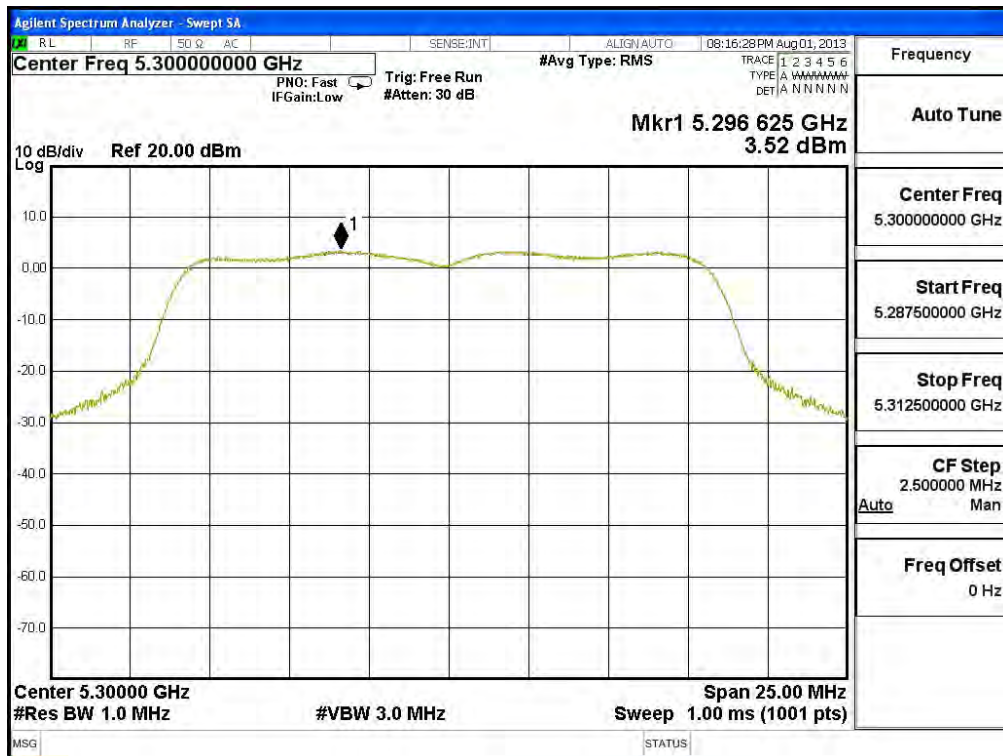

Channel 64: CHAIN A

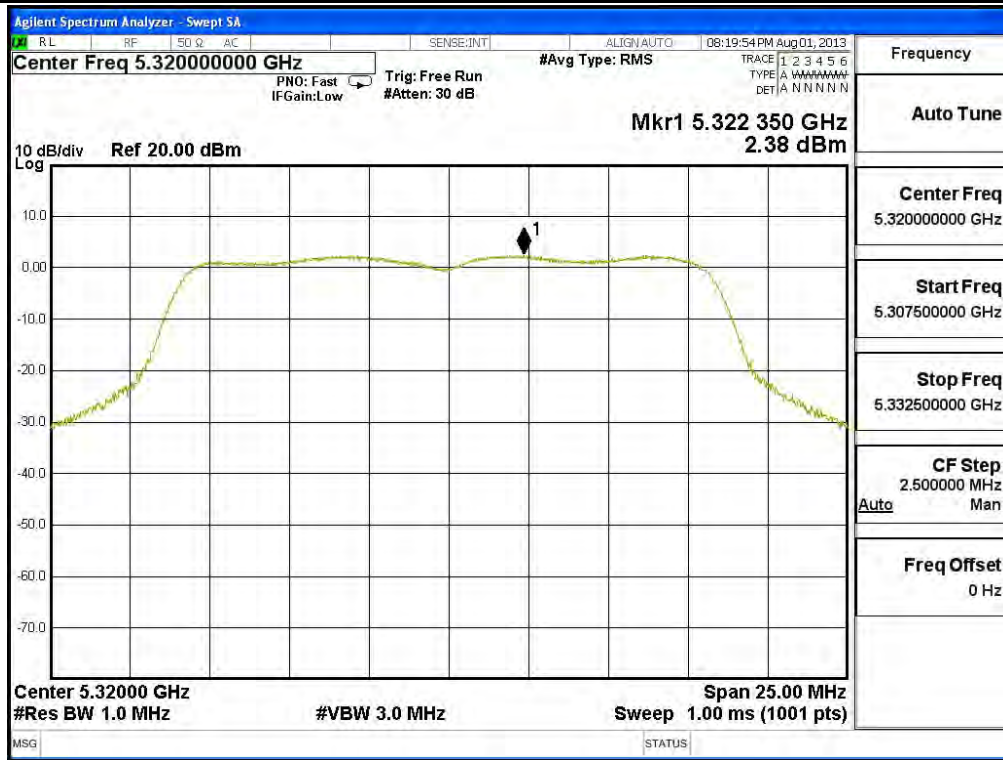

Channel 100: CHAIN A

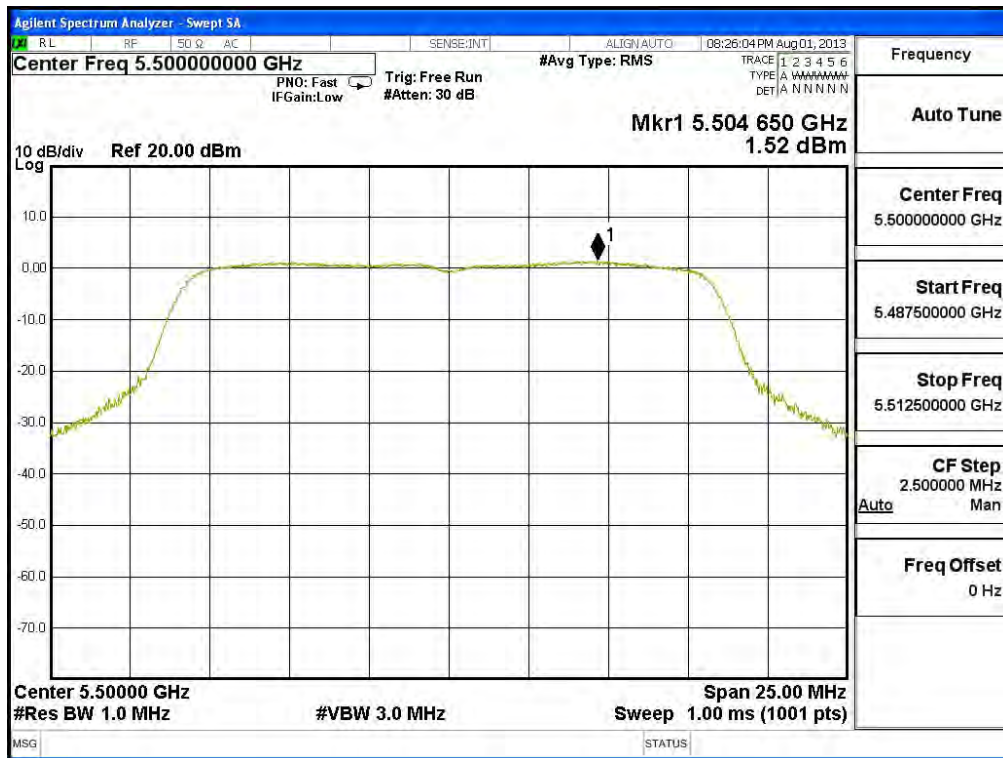

Channel 120: CHAIN A

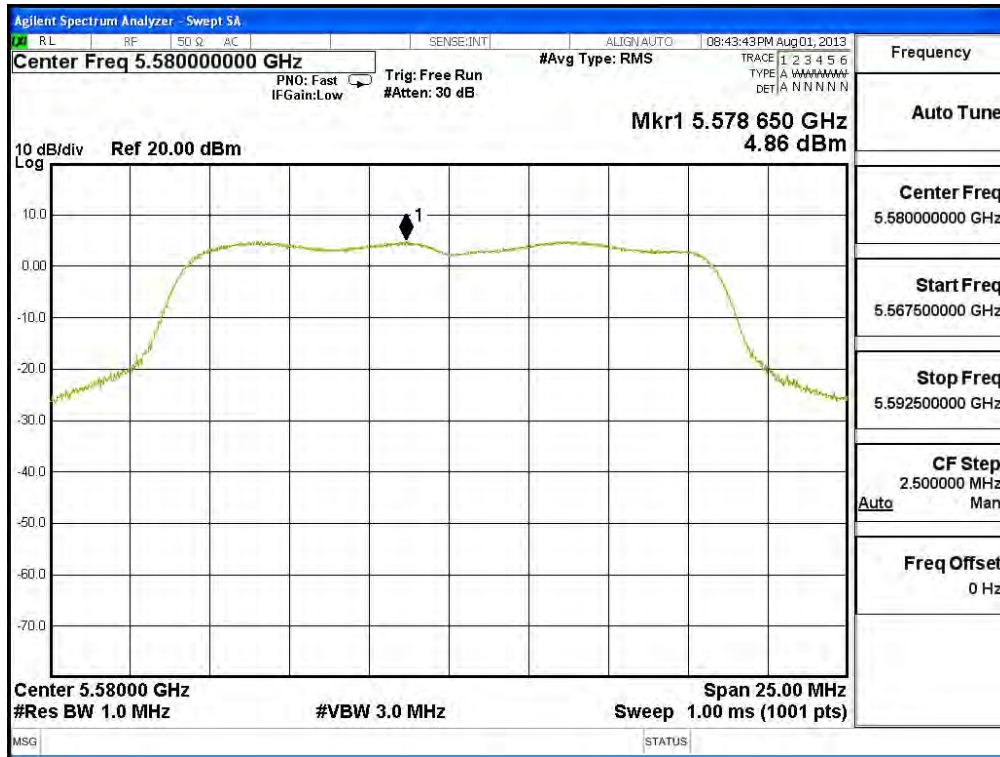

Channel 140: CHAIN A

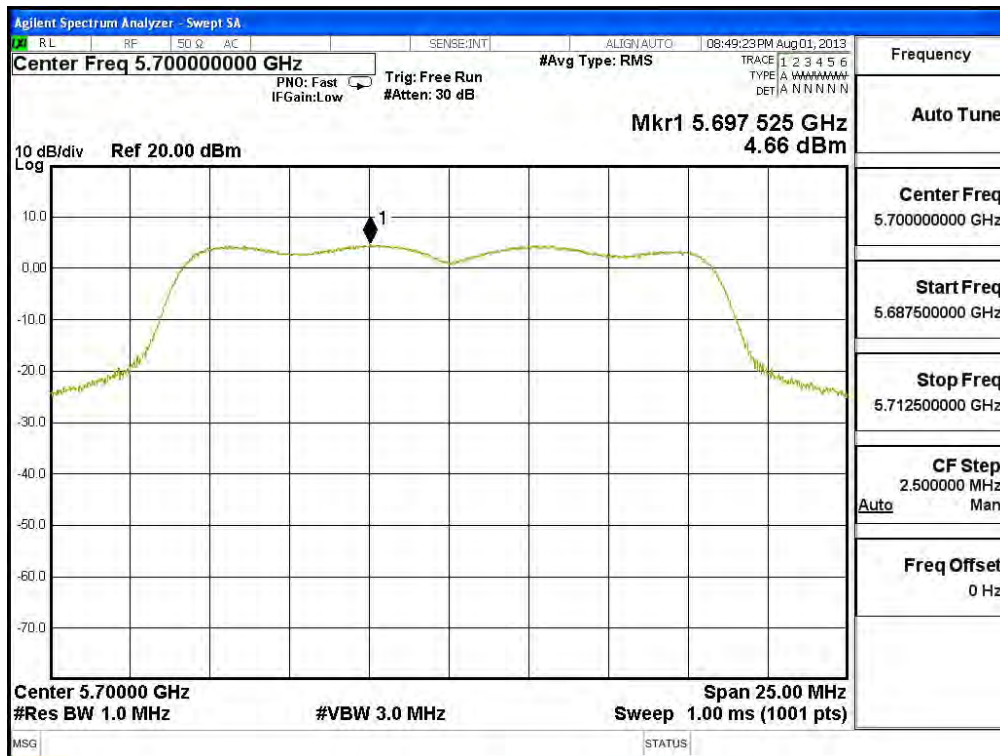

Channel 52: CHAIN B

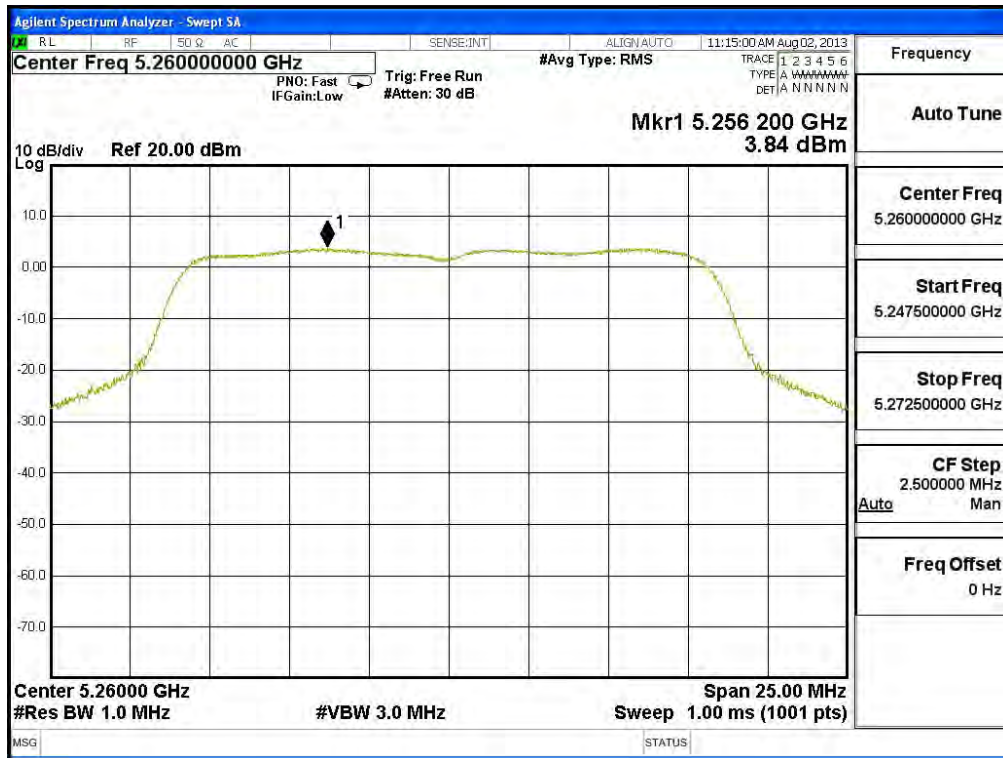

Channel 60: CHAIN B

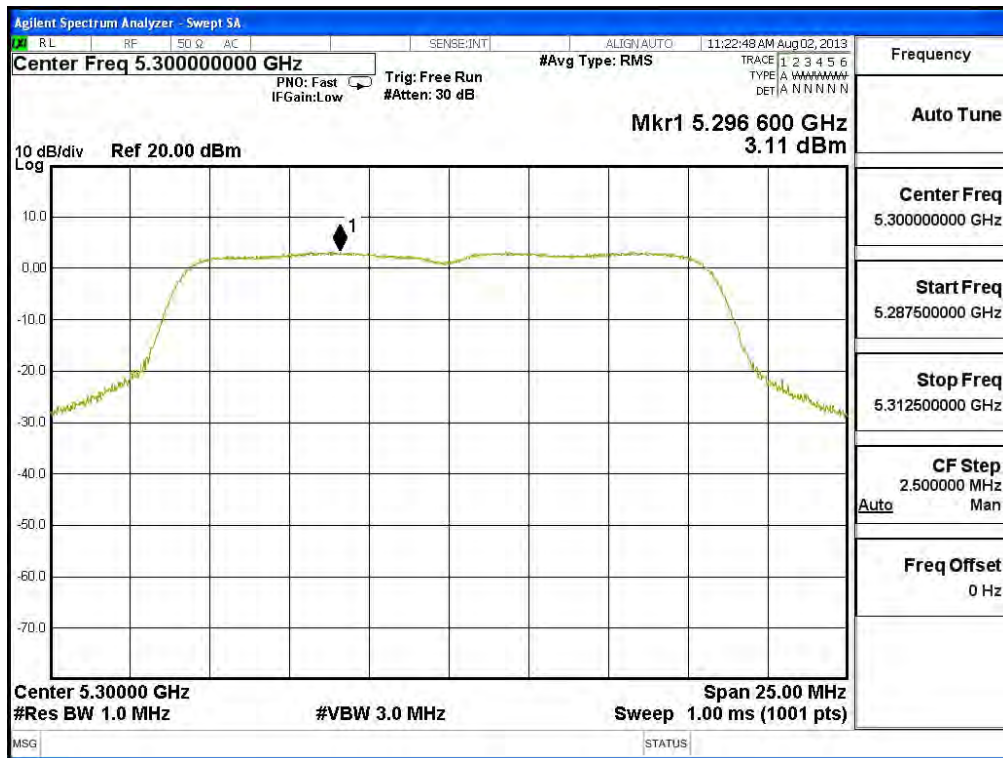

Channel 64: CHAIN B

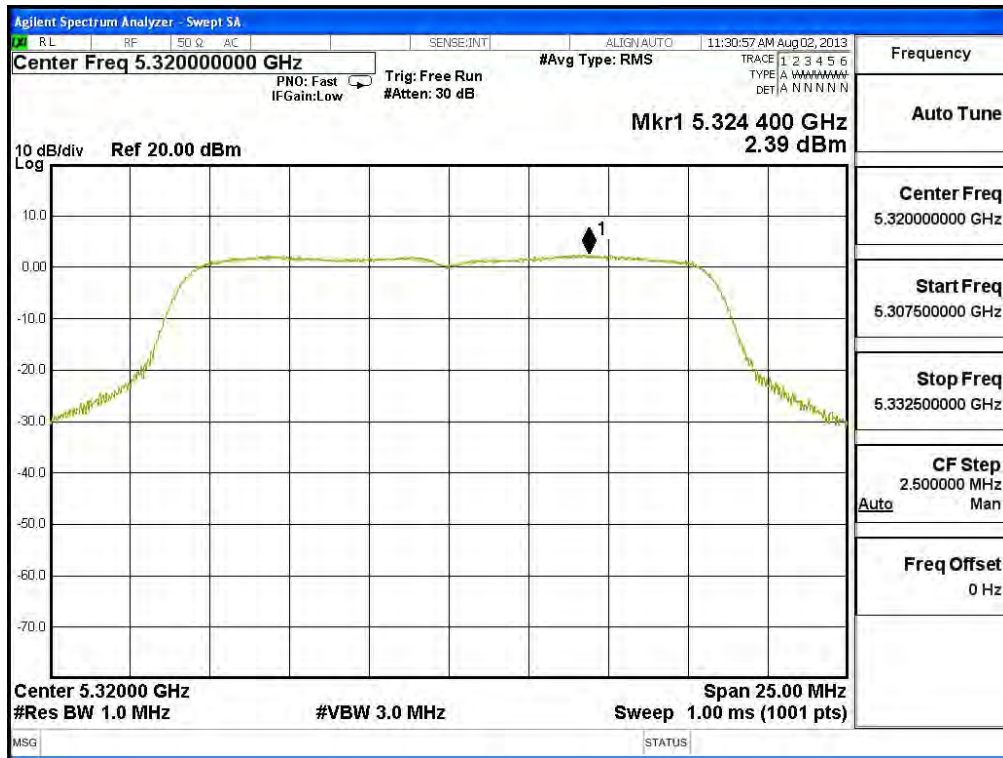

Channel 100: CHAIN B

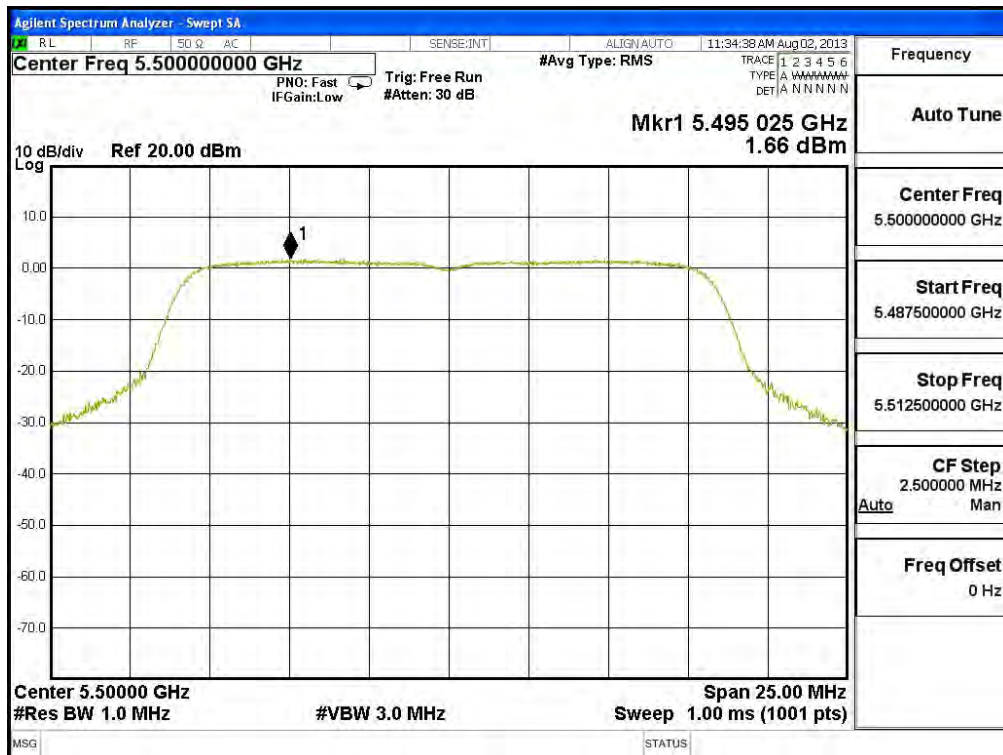

Channel 120: CHAIN B

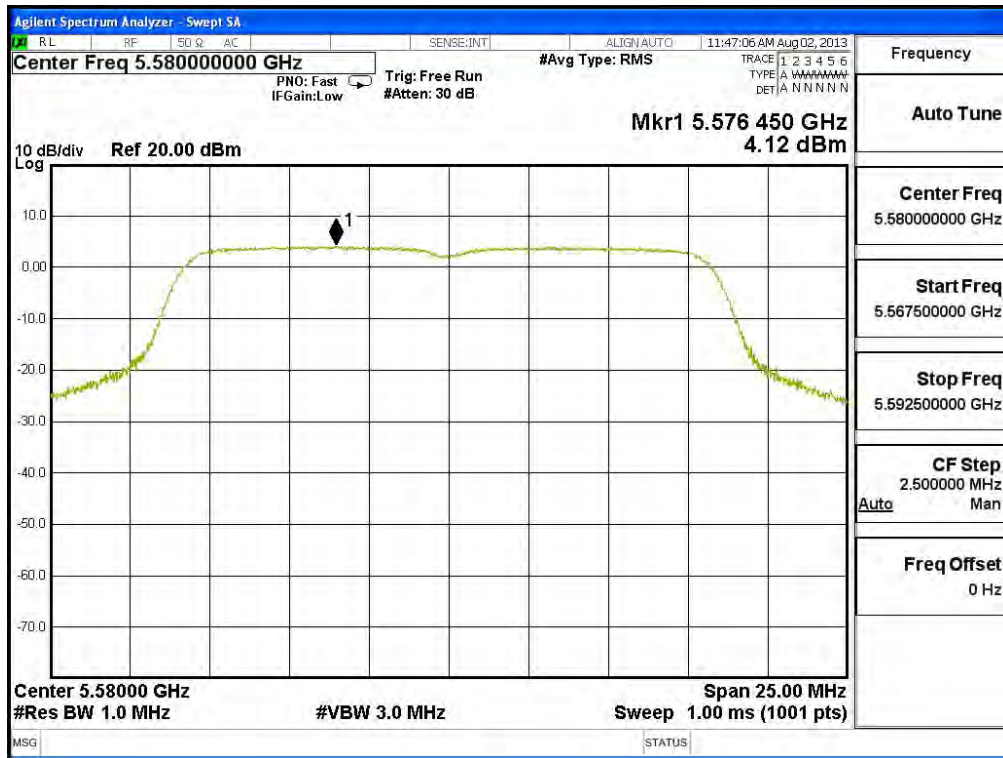

Channel 140: CHAIN B

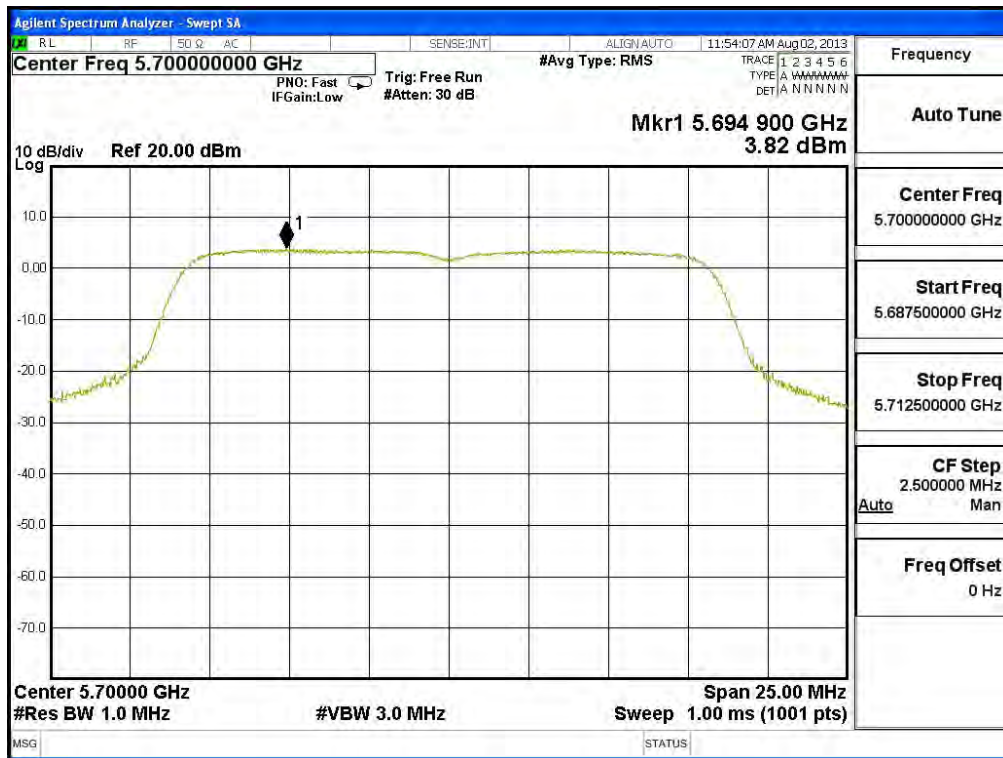

Product : SpectraGuard® Access Point / Sensor
 Test Item : Peak Power Spectral Density
 Test Site : No.3 OATS
 Test Mode : Mode 2: Transmit (802.11n-20BW 14.4Mbps)(Dipole Antenna)

Channel Number	Frequency (MHz)	Chain	PPSD/MHz (dBm)	Total PPSD/MHz (dBm) ₁	Required Limit (dBm)	Result
52	5260	A	3.520	6.530	<11	Pass
		B	2.740	5.750	<11	Pass
60	5300	A	2.240	5.250	<11	Pass
		B	2.310	5.320	<11	Pass
64	5320	A	0.930	3.940	<11	Pass
		B	0.930	3.940	<11	Pass
100	5500	A	-0.660	2.350	<11	Pass
		B	-0.140	2.870	<11	Pass
116	5580	A	3.350	6.360	<11	Pass
		B	2.790	5.800	<11	Pass
140	5700	A	3.730	6.740	<11	Pass
		B	2.820	5.830	<11	Pass

Note 1: The quantity $10 \cdot \log 2$ (two antennas) is added to the spectrum peak value according to document 662911 D01.

Channel 52 – Chain A

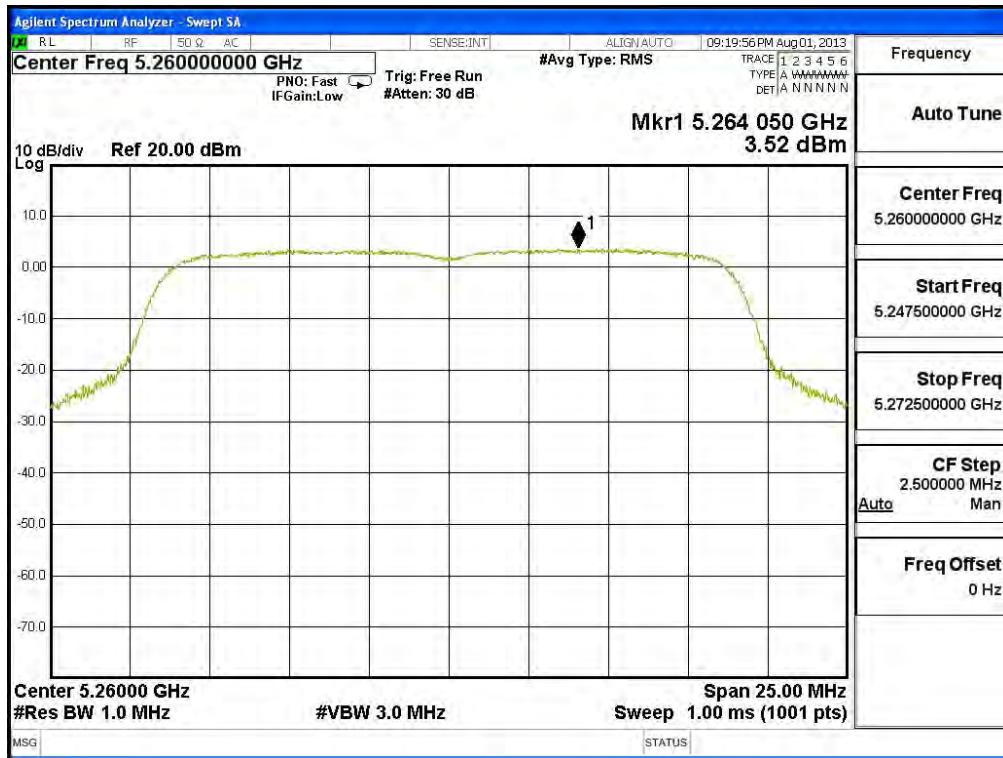

Channel 60 – Chain A

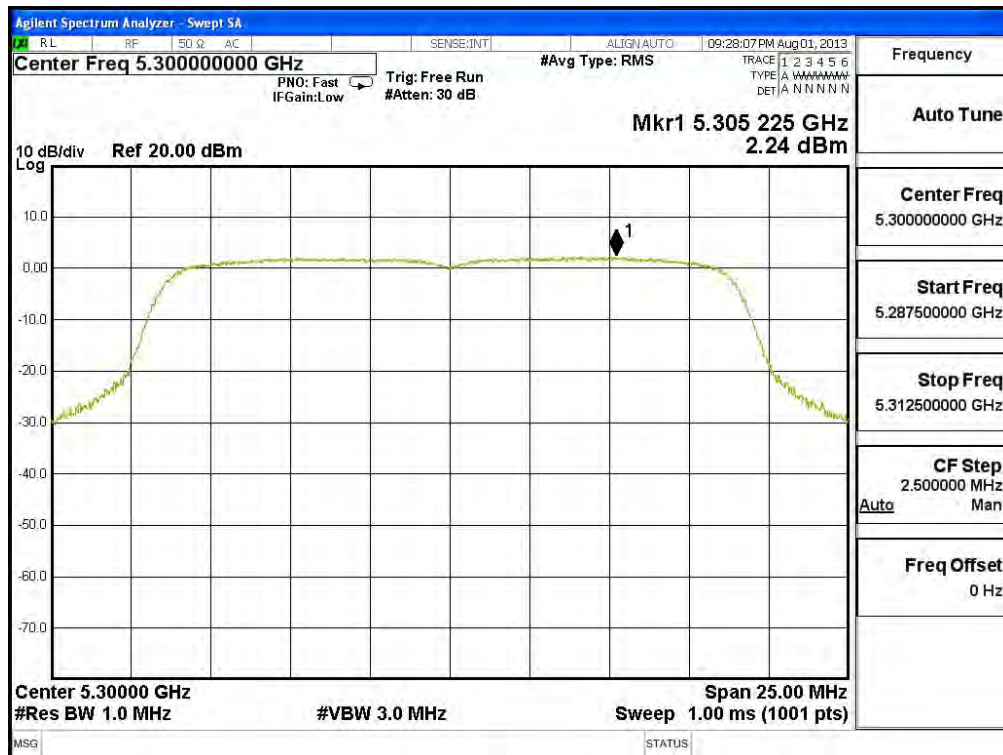

Channel 64 – Chain A

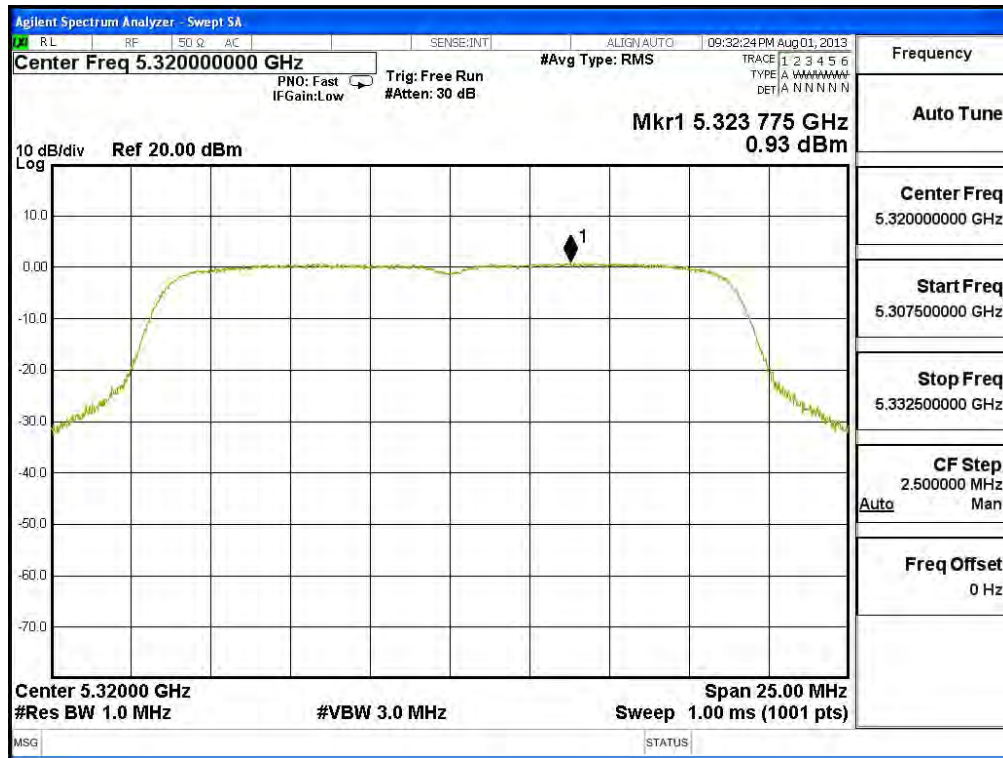

Channel 100 – Chain A

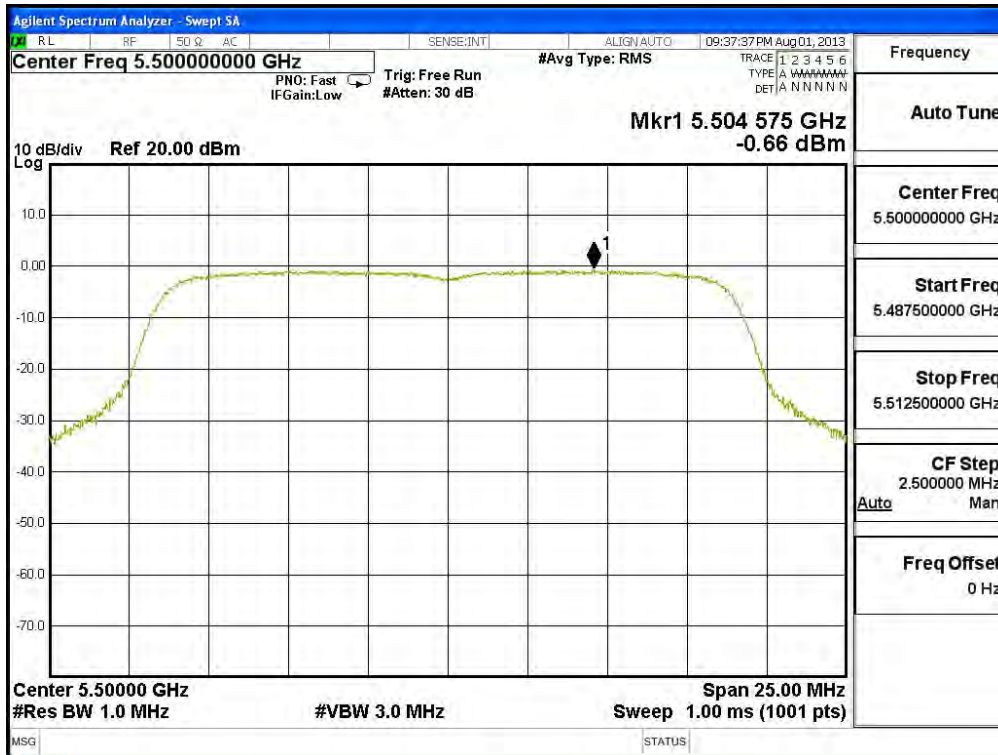

Channel 120 – Chain A

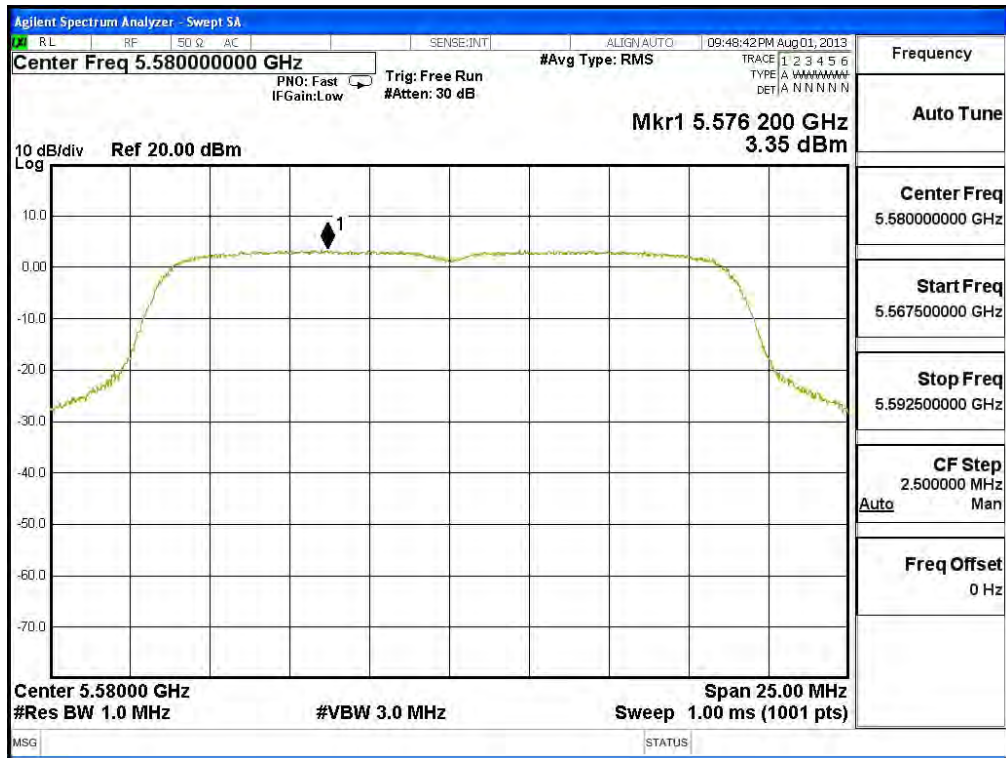

Channel 140 – Chain A

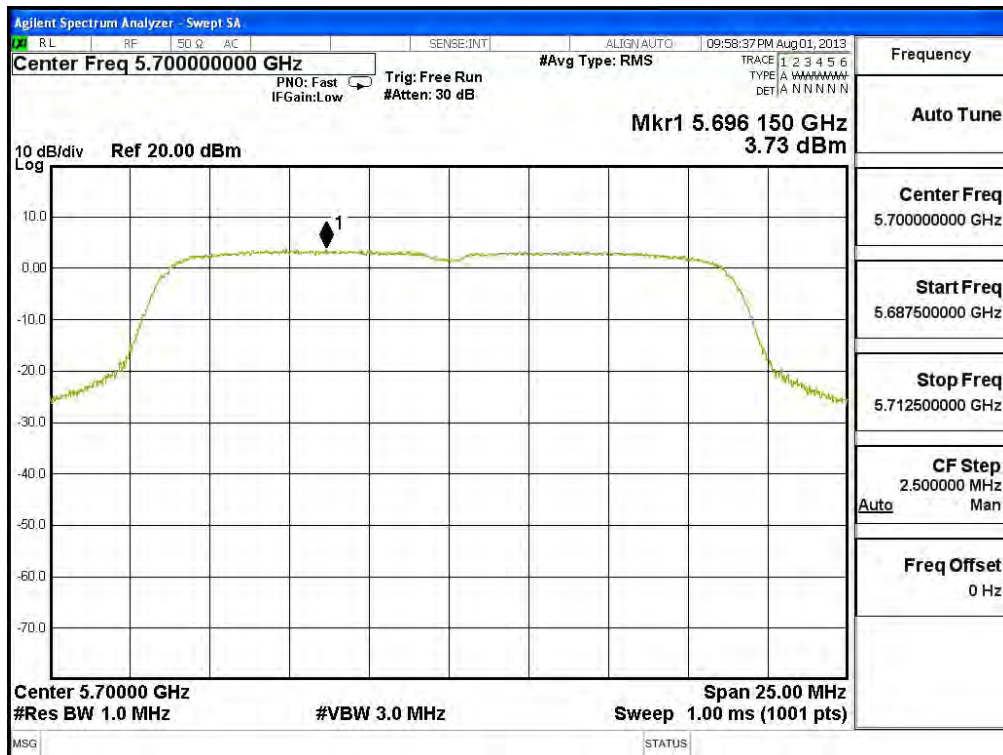

Channel 52 – Chain B

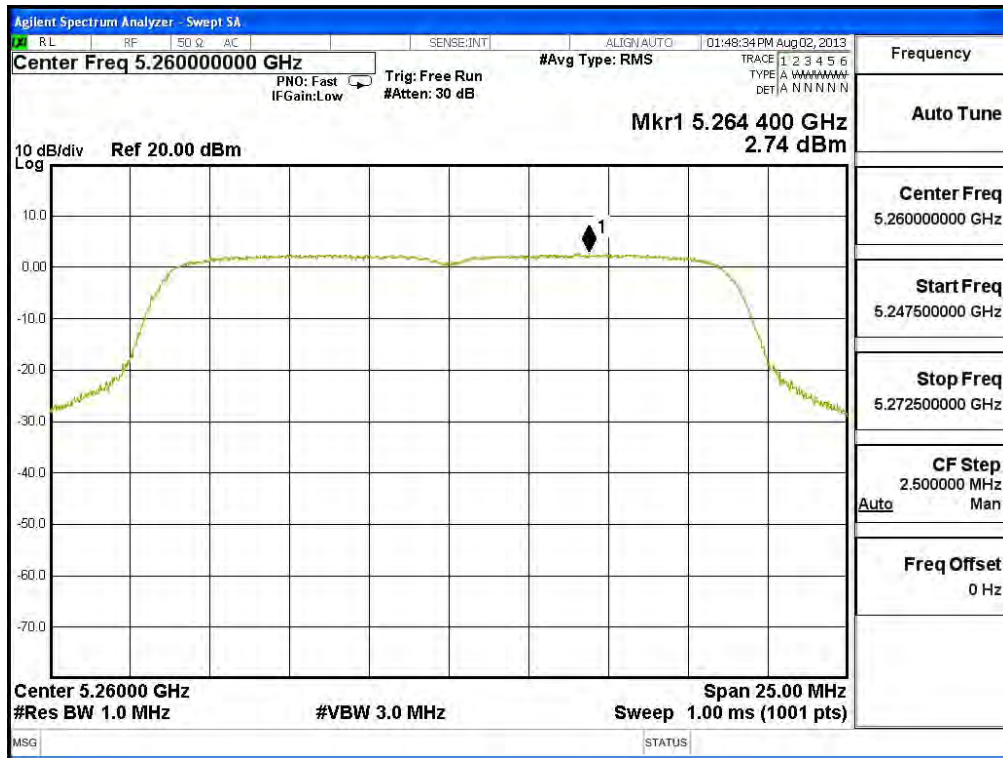

Channel 60 – Chain B

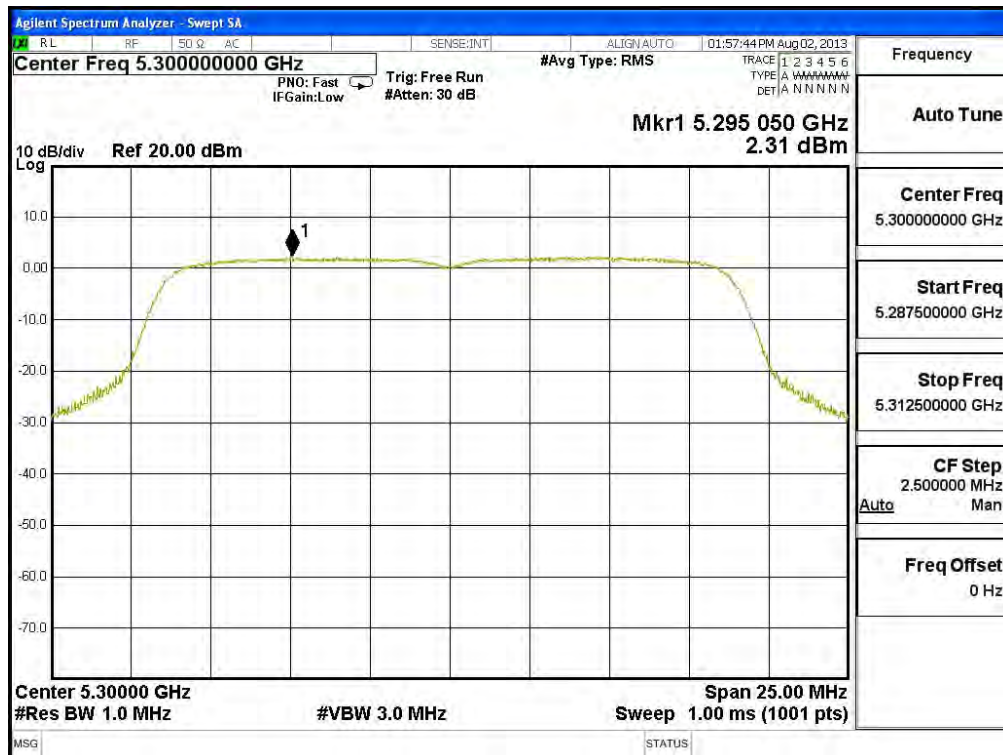

Channel 64 – Chain B

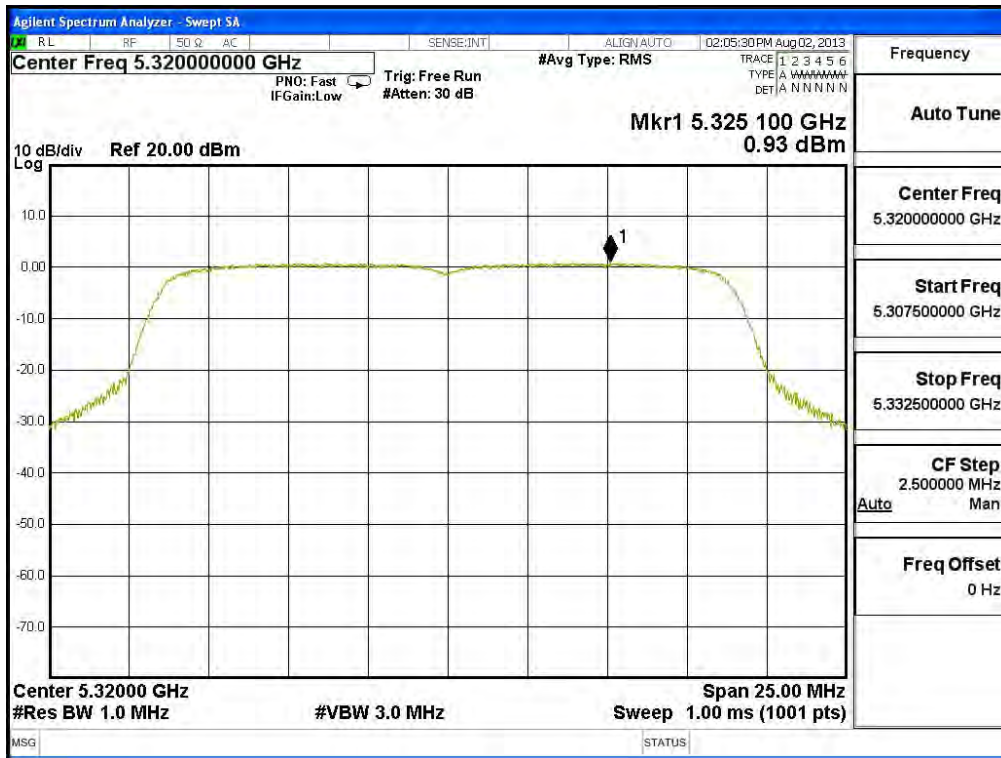

Channel 100 – Chain B

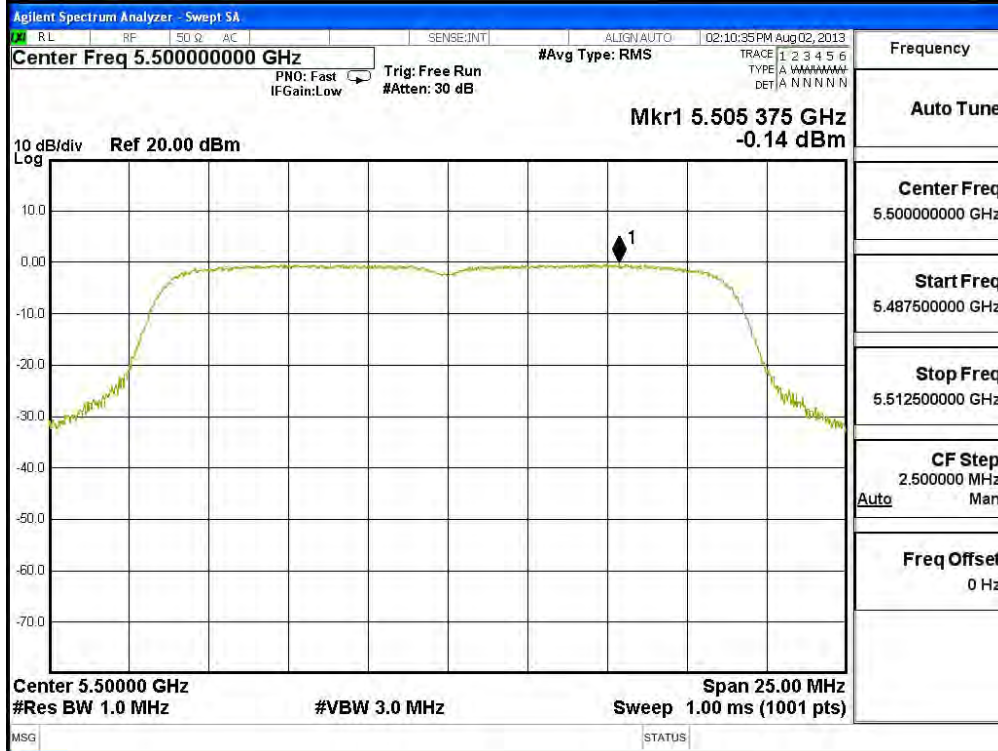

Channel 120 – Chain B

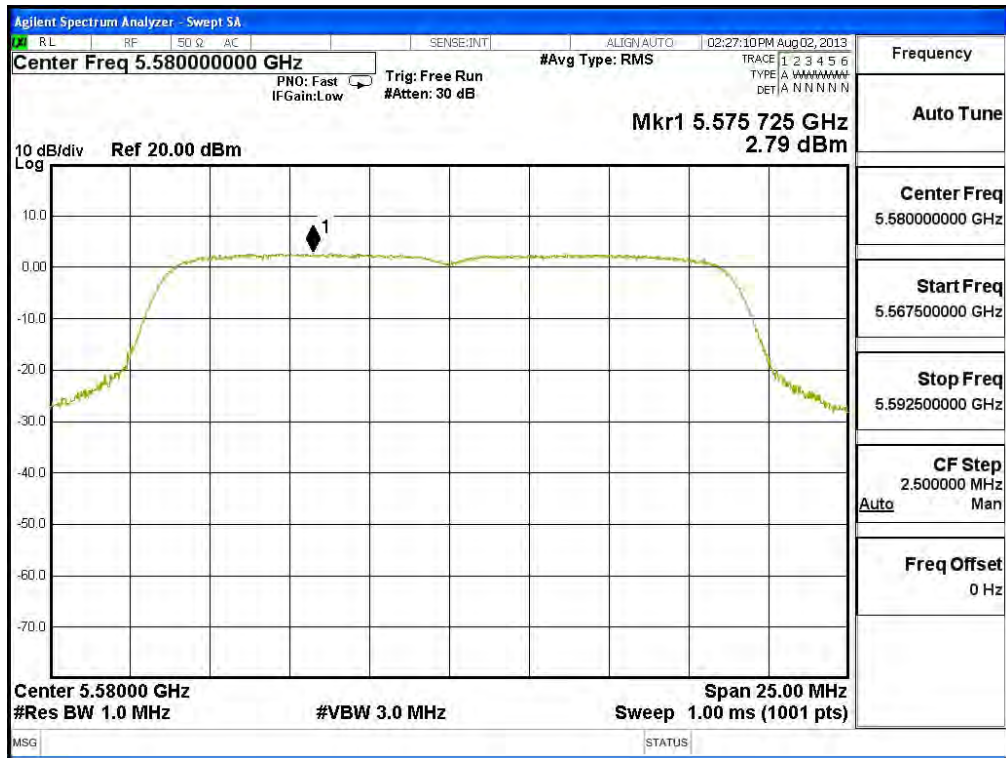

Channel 140 – Chain B

