

# FCC Test Report

Product Name	SpectraGuard® Access Point / Sensor
Model No	SS-300AT-C-60
FCC ID	TOR-SS300ATC60

Applicant	AirTight Networks, Inc.
Address	339 N. Bernardo Avenue, Suite #200, Mountain View, California, USA

Date of Receipt	Jul. 03, 2013
Issued Date	Aug. 20, 2013
Report No.	137146R-RFUSP31V01
Report Version	V1.0



The test results relate only to the samples tested.

The test report shall not be reproduced except in full without the written approval of QuieTek Corporation.

# Test Report Certification

Issued Date: Aug. 20, 2013

Report No.: 137146R-RFUSP31V01



Product Name	SpectraGuard® Access Point / Sensor
Applicant	AirTight Networks, Inc.
Address	339 N. Bernardo Avenue, Suite #200, Mountain View, California, USA
Manufacturer	DONG GUAN G-COM COMPUTER CO., LTD.
Model No.	SS-300AT-C-60
FCC ID.	TOR-SS300ATC60
EUT Rated Voltage	DC 12V
EUT Test Voltage	AC 120V/60Hz
Trade Name	AirTight
Applicable Standard	FCC CFR Title 47 Part 15 Subpart E: 2012 ANSI C63.4: 2003, ANSI C63.10: 2009, FCC KDB-789033
Test Result	Complied

The Test Results relate only to the samples tested.

The test report shall not be reproduced except in full without the written approval of Quietek Corporation.

Documented By : Leven Huang  
(Senior Adm. Specialist / Leven Huang)

Tested By : Jack Hsu  
(Engineer / Jack Hsu)

Approved By : Vincent Lin  
(Manager / Vincent Lin)

## TABLE OF CONTENTS

Description	Page
<b>1. GENERAL INFORMATION</b>	<b>5</b>
1.1. EUT Description	5
1.2. Operational Description	7
1.3. Tested System Details	8
1.4. Configuration of tested System	8
1.5. EUT Exercise Software	8
1.6. Test Facility	9
<b>2. Conducted Emission</b>	<b>10</b>
2.1. Test Equipment	10
2.2. Test Setup	10
2.3. Limits	11
2.4. Test Procedure	11
2.5. Uncertainty	11
2.6. Test Result of Conducted Emission	12
<b>3. Maximum conducted output power</b>	<b>16</b>
3.1. Test Equipment	16
3.2. Test Setup	16
3.3. Limits	17
3.4. Test Procedure	17
3.5. Uncertainty	17
3.6. Test Result of Maximum conducted output power	18
<b>4. Peak Power Spectral Density</b>	<b>52</b>
4.1. Test Equipment	52
4.2. Test Setup	52
4.3. Limits	52
4.4. Test Procedure	53
4.5. Uncertainty	53
4.6. Test Result of Peak Power Spectral Density	54
<b>5. Peak Excursion</b>	<b>90</b>
5.1. Test Equipment	90
5.2. Test Setup	90
5.3. Limits	90
5.4. Test Procedure	91
5.5. Uncertainty	91
5.6. Test Result of Peak Excursion	92
<b>6. Radiated Emission</b>	<b>146</b>
6.1. Test Equipment	146
6.2. Test Setup	146
6.3. Limits	147
6.4. Test Procedure	148
6.5. Uncertainty	148
6.6. Test Result of Radiated Emission	149
<b>7. Band Edge</b>	<b>171</b>

---

7.1.	Test Equipment.....	171
7.2.	Test Setup .....	172
7.3.	Limits .....	173
7.4.	Test Procedure .....	173
7.5.	Uncertainty .....	173
7.6.	Test Result of Band Edge .....	174
<b>8.</b>	<b>Frequency Stability.....</b>	<b>204</b>
8.1.	Test Equipment.....	204
8.2.	Test Setup .....	204
8.3.	Limits .....	204
8.4.	Test Procedure .....	204
8.5.	Uncertainty .....	204
8.6.	Test Result of Frequency Stability.....	205
<b>9.</b>	<b>EMI Reduction Method During Compliance Testing .....</b>	<b>211</b>
Attachment 1:	EUT Test Photographs	
Attachment 2:	EUT Detailed Photographs	

## 1. GENERAL INFORMATION

### 1.1. EUT Description

Product Name	SpectraGuard® Access Point / Sensor
Trade Name	AirTight
Model No.	SS-300AT-C-60
FCC ID.	TOR-SS300ATC60
Frequency Range	802.11a/n-20MHz: 5180-5240MHz 802.11n-40MHz: 5190-5230MHz
Number of Channels	802.11a/n-20MHz: 4, n-40MHz: 2
Data Rate	802.11a/g: 6-54Mbps, 802.11n: up to 450Mbps
Channel Control	Auto
Type of Modulation	802.11a/n:OFDM, BPSK, QPSK, 16QAM, 64QAM
Antenna type	Dipole / PIFA
Antenna Gain	Refer to the table “Antenna List”

#### Antenna List

No.	Manufacturer	Part No.	Peak Gain	Note
1.	JOYMAX	JWX-614XRSXX-361 JWX-614XRSXX-361 JWX-614XRSXX-361	5dBi for 5.15~5.25GHz	External Antenna (Dipole)
2.	MAG.LAYERS	MSA-3810-2G4C1-B4 MSA-3810-2G4C1-B3 MSA-3810-2G4C1-A37	3.87dBi for 5.15~5.25GHz	Internal Antenna (PIFA)

Note: The antenna of EUT is conform to FCC 15.203

## 802.11a/n-20MHz Center Working Frequency of Each Channel:

Channel	Frequency	Channel	Frequency	Channel	Frequency	Channel	Frequency
Channel 36:	5180 MHz	Channel 40:	5200 MHz	Channel 44:	5220 MHz	Channel 48:	5240 MHz

## 802.11n-40MHz Center Working Frequency of Each Channel:

Channel	Frequency	Channel	Frequency
Channel 38:	5190 MHz	Channel 46:	5230 MHz

## Note:

1. This device is a SpectraGuard® Access Point / Sensor with a built-in two WLAN module, module 1 support 2T2R, module 2 support 3T3R technology, this report for 3T3R module.
2. Regarding to the operation frequency, the lowest, middle and highest frequency are selected to perform the test.
3. Lowest and highest data rates are tested in each mode. Only worst case is shown in the report. (802.11a is 6Mbps, 802.11n-20BW is 21.7Mbps and 802.11n-40BW are 45Mbps)
4. These tests were conducted on a sample of the equipment for the purpose of demonstrating compliance with Part 15 Subpart E for Unlicensed National Information Infrastructure devices.
5. The radiation measurements are performed in X, Y, Z axis positioning. Only the worst case is shown in the report.

Test Mode	Mode 1: Transmit (802.11a-6Mbps)(Dipole Antenna) Mode 2: Transmit (802.11n-20BW 21.7Mbps)(Dipole Antenna) Mode 3: Transmit (802.11n-40BW 45Mbps)(Dipole Antenna) Mode 4: Transmit (802.11a-6Mbps)(PIFA Antenna) Mode 5: Transmit (802.11n-20BW 21.7Mbps)(PIFA Antenna) Mode 6: Transmit (802.11n-40BW 45Mbps)(PIFA Antenna)
-----------	--

### 1.3. Tested System Details

The types for all equipment, plus descriptions of all cables used in the tested system (including inserted cards) are:

Product	Manufacturer	Model No.	Serial No.	Power Cord
(1) Notebook PC	DELL	PPT	N/A	Non-Shielded, 0.8m
(2) Power Adapter	DVE	DSA-15P-12 US 120150	N/A	Non-Shielded, 1.7m

Signal Cable Type	Signal cable Description
A RJ45 Cable	Non-Shielded, 5.0m
B RJ45 to RS-232 Cable	Non-Shielded, 5.0m
C RJ45 Cable	Non-Shielded, 5.0m
D Power Cable	Non-Shielded, 1.7m

### 1.4. Configuration of tested System

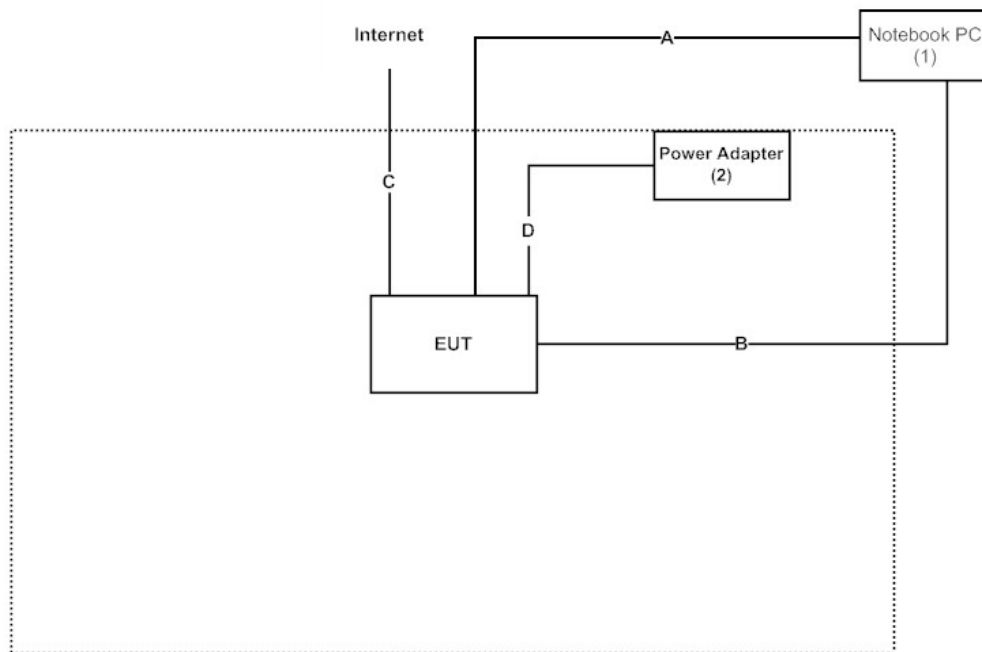

### 1.5. EUT Exercise Software

- (1) Connect EUT and Notebook via RJ45 & RS232 Cable
- (2) Execute “Art2-GUI V2.3” program on the Notebook PC.
- (3) Configure the test mode, the test channel, and the data rate.
- (4) Start the continuous transmission.
- (5) Verify that the EUT works properly.

## 1.6. Test Facility

Ambient conditions in the laboratory:

Items	Required (IEC 68-1)	Actual
Temperature (°C)	15-35	20-35
Humidity (%RH)	25-75	50-65
Barometric pressure (mbar)	860-1060	950-1000

The related certificate for our laboratories about the test site and management system can be downloaded from Quietek Corporation's Web Site : <http://tw.quietek.com/modules/myalbum/>

The address and introduction of Quietek Corporation's laboratories can be founded in our Web site : <http://www.quietek.com/>

Site Description: File on  
Federal Communications Commission  
FCC Engineering Laboratory  
7435 Oakland Mills Road  
Columbia, MD 21046  
Registration Number: 92195

Site Name: Quietek Corporation  
Site Address: No.5-22, Ruishukeng,  
Linkou Dist. New Taipei City 24451,  
Taiwan, R.O.C.  
TEL: 886-2-8601-3788 / FAX : 886-2-8601-3789  
E-Mail : [service@quietek.com](mailto:service@quietek.com)

FCC Accreditation Number: TW1014



## 2. Conducted Emission

### 2.1. Test Equipment

	Equipment	Manufacturer	Model No. / Serial No.	Last Cal.	Remark
X	Test Receiver	R & S	ESCS 30 / 825442/018	Sep., 2012	
X	Artificial Mains Network	R & S	ENV4200 / 848411/10	Feb., 2013	Peripherals
X	LISN	R & S	ESH3-Z5 / 825562/002	Feb., 2013	EUT
	DC LISN	Schwarzbeck	8226 / 176	Mar, 2013	EUT
X	Pulse Limiter	R & S	ESH3-Z2 / 357.8810.52	Feb., 2013	
	No.1 Shielded Room				

Note:

1. All equipments are calibrated every one year.
2. The test instruments marked by "X" are used to measure the final test results.

### 2.2. Test Setup

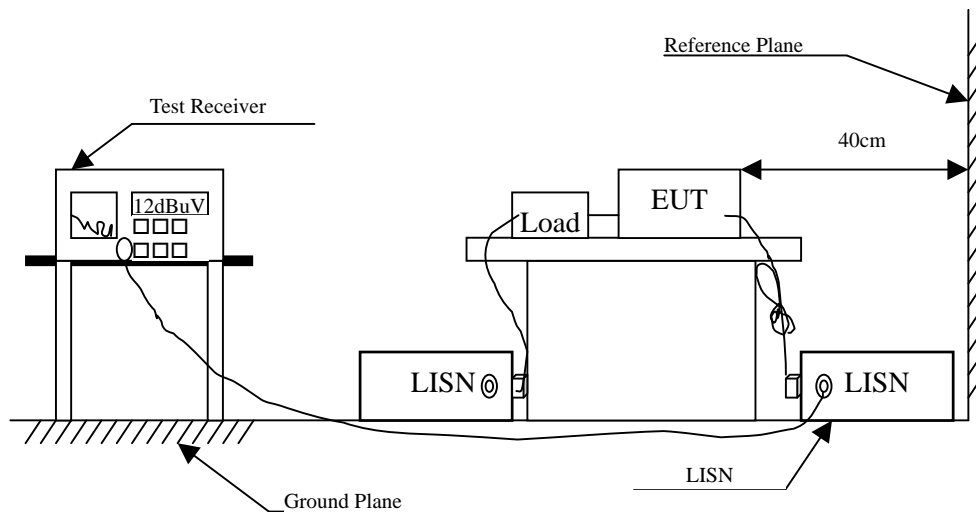

**2.3. Limits**

<b>FCC Part 15 Subpart C Paragraph 15.207 (dBuV) Limit</b>		
Frequency MHz	Limits	
	QP	AV
0.15 - 0.50	66-56	56-46
0.50-5.0	56	46
5.0 - 30	60	50

Remarks : In the above table, the tighter limit applies at the band edges.

**2.4. Test Procedure**

The EUT and simulators are connected to the main power through a line impedance stabilization network (L.I.S.N.). This provides a 50 ohm /50uH coupling impedance for the measuring equipment. The peripheral devices are also connected to the main power through a LISN that provides a 50ohm /50uH coupling impedance with 50ohm termination. (Please refers to the block diagram of the test setup and photographs.)

Both sides of A.C. line are checked for maximum conducted interference. In order to find the maximum emission, the relative positions of equipment and all of the interface cables must be changed according to ANSI C63.10: 2009 on conducted measurement.

Conducted emissions were invested over the frequency range from 0.15MHz to 30MHz using a receiver bandwidth of 9kHz.

The EUT was setup to ANSI C63.10, 2009; tested to DTS test procedure of FCC KDB-789033 for compliance to FCC 47CFR Subpart E requirements.

**2.5. Uncertainty**

± 2.26 dB

## 2.6. Test Result of Conducted Emission

Product : SpectraGuard® Access Point / Sensor  
 Test Item : Conducted Emission Test  
 Power Line : Line 1  
 Test Mode : Mode 3: Transmit (802.11n-40BW 45Mbps)(Dipole Antenna) (5190MHz)

Frequency MHz	Correct Factor dB	Reading Level dBuV	Measurement Level dBuV	Margin dB	Limit dBuV
<b>LINE 1</b>					
<b>Quasi-Peak</b>					
0.177	9.932	36.590	46.522	-18.707	65.229
0.287	9.877	25.010	34.887	-27.199	62.086
0.341	9.869	25.400	35.269	-25.274	60.543
0.576	9.821	19.420	29.241	-26.759	56.000
0.865	9.770	21.190	30.960	-25.040	56.000
11.162	10.210	33.630	43.840	-16.160	60.000
<b>Average</b>					
0.177	9.932	13.170	23.102	-32.127	55.229
0.287	9.877	6.220	16.097	-35.989	52.086
0.341	9.869	20.110	29.979	-20.564	50.543
0.576	9.821	8.660	18.481	-27.519	46.000
0.865	9.770	11.940	21.710	-24.290	46.000
11.162	10.210	26.340	36.550	-13.450	50.000

Note:

1. All Reading Levels are Quasi-Peak and average value.
2. "■" means the worst emission level.
3. Measurement Level = Reading Level + Correct Factor

Product : SpectraGuard® Access Point / Sensor  
 Test Item : Conducted Emission Test  
 Power Line : Line 2  
 Test Mode : Mode 3: Transmit (802.11n-40BW 45Mbps)(Dipole Antenna) (5190MHz)

Frequency MHz	Correct Factor dB	Reading Level dBuV	Measurement Level dBuV	Margin dB	Limit dBuV
<b>LINE 2</b>					
<b>Quasi-Peak</b>					
0.189	9.770	36.960	46.730	-18.156	64.886
0.212	9.754	36.160	45.914	-18.315	64.229
0.302	9.750	27.440	37.190	-24.467	61.657
0.459	9.760	18.300	28.060	-29.111	57.171
0.861	9.770	16.050	25.820	-30.180	56.000
11.240	10.080	27.990	38.070	-21.930	60.000
<b>Average</b>					
0.189	9.770	7.390	17.160	-37.726	54.886
0.212	9.754	7.690	17.444	-36.785	54.229
0.302	9.750	8.590	18.340	-33.317	51.657
0.459	9.760	-0.730	9.030	-38.141	47.171
0.861	9.770	5.030	14.800	-31.200	46.000
11.240	10.080	19.040	29.120	-20.880	50.000

Note:

1. All Reading Levels are Quasi-Peak and average value.
2. "■" means the worst emission level.
3. Measurement Level = Reading Level + Correct Factor

Product : SpectraGuard® Access Point / Sensor  
 Test Item : Conducted Emission Test  
 Power Line : Line 1  
 Test Mode : Mode 6: Transmit (802.11n-40BW 45Mbps)(PIFA Antenna) (5190MHz)

Frequency MHz	Correct Factor dB	Reading Level dBuV	Measurement Level dBuV	Margin dB	Limit dBuV
<b>LINE 1</b>					
<b>Quasi-Peak</b>					
0.158	9.951	38.470	48.421	-17.350	65.771
0.189	9.920	35.000	44.920	-19.966	64.886
0.271	9.885	22.110	31.995	-30.548	62.543
0.361	9.863	18.610	28.473	-31.498	59.971
0.502	9.856	12.970	22.826	-33.174	56.000
11.072	10.200	33.420	43.620	-16.380	60.000
<b>Average</b>					
0.158	9.951	9.780	19.731	-36.040	55.771
0.189	9.920	7.310	17.230	-37.656	54.886
0.271	9.885	11.790	21.675	-30.868	52.543
0.361	9.863	3.790	13.653	-36.318	49.971
0.502	9.856	2.840	12.696	-33.304	46.000
11.072	10.200	26.280	36.480	-13.520	50.000

Note:

1. All Reading Levels are Quasi-Peak and average value.
2. "■" means the worst emission level.
3. Measurement Level = Reading Level + Correct Factor

Product : SpectraGuard® Access Point / Sensor  
 Test Item : Conducted Emission Test  
 Power Line : Line 2  
 Test Mode : Mode 6: Transmit (802.11n-40BW 45Mbps)(PIFA Antenna) (5190MHz)

Frequency MHz	Correct Factor dB	Reading Level dBuV	Measurement Level dBuV	Margin dB	Limit dBuV
<b>LINE 2</b>					
<b>Quasi-Peak</b>					
0.181	9.780	32.410	42.190	-22.924	65.114
0.255	9.758	25.990	35.748	-27.252	63.000
0.287	9.750	26.840	36.590	-25.496	62.086
0.447	9.760	14.350	24.110	-33.404	57.514
0.822	9.770	14.790	24.560	-31.440	56.000
11.845	10.100	27.040	37.140	-22.860	60.000
<b>Average</b>					
0.181	9.780	6.690	16.470	-38.644	55.114
0.255	9.758	0.120	9.878	-43.122	53.000
0.287	9.750	1.420	11.170	-40.916	52.086
0.447	9.760	2.620	12.380	-35.134	47.514
0.822	9.770	3.560	13.330	-32.670	46.000
11.845	10.100	18.290	28.390	-21.610	50.000

Note:

1. All Reading Levels are Quasi-Peak and average value.
2. "■" means the worst emission level.
3. Measurement Level = Reading Level + Correct Factor

### 3. Maximun conducted output power

#### 3.1. Test Equipment

	Equipment	Manufacturer	Model No./Serial No.	Last Cal.
X	Power Meter	Anritsu	ML2495A/6K00003357	May, 2013
X	Power Sensor	Anritsu	MA2411B/0738448	Jun, 2013
X	Spectrum Analyzer	Agilent	N9010A / MY48030495	Apr., 2013

Note:

1. All equipments are calibrated with traceable calibrations. Each calibration is traceable to the national or international standards.
2. The test instruments marked with “X” are used to measure the final test results.

#### 3.2. Test Setup

##### 26dBc Occupied Bandwidth

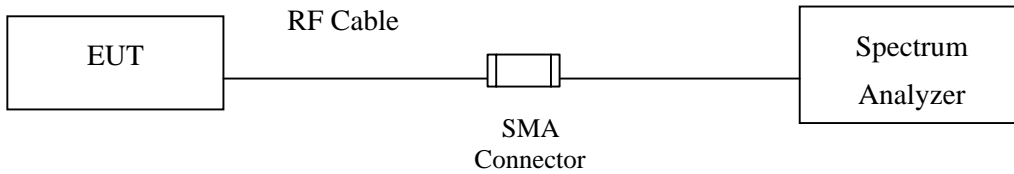

##### Conduction Power Measurement

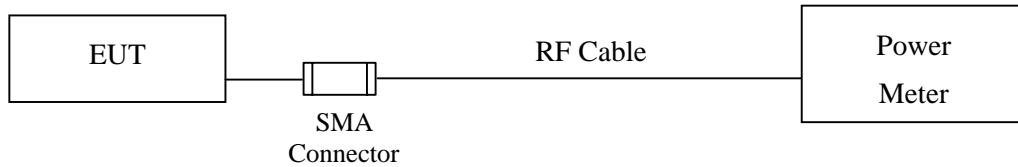

### 3.3. Limits

- (1) For the band 5.15-5.25 GHz, the maximum conducted output power over the frequency band of operation shall not exceed the lesser of 50 mW or  $4 \text{ dBm} + 10\log B$ , where B is the 26-dB emission bandwidth in MHz. If transmitting antenna of directional gain greater than 6 dBi are used, the peak transmit power shall be reduced by the amount in dB that directional gain of the antenna exceeds 6 dBi.
- (2) For the band 5.25-5.35 GHz, the maximum conducted output power over the frequency band of operation shall not exceed the lesser of 250 mW or  $11 \text{ dBm} + 10\log B$ , where B is the 26-dB emission bandwidth in MHz. If transmitting antenna of directional gain greater than 6 dBi are used, the peak transmit power shall be reduced by the amount in dB that directional gain of the antenna exceeds 6 dBi.
- (3) For the band 5.725-5.825 GHz, the maximum conducted output power over the frequency band of operation shall not exceed the lesser of 1W or  $17 \text{ dBm} + 10\log B$ , where B is the 26-dB emission bandwidth in MHz. If transmitting antenna of directional gain greater than 6 dBi are used, the peak transmit power shall be reduced by the amount in dB that directional gain of the antenna exceeds 6 dBi.

### 3.4. Test Procedur

As an alternative to FCC KDB-789033, the EUT maximum conducted output power was measured with an average power meter employing a video bandwidth greater than 6dB BW of the emission under test. Maximum conducted output power was read directly from the meter across all data rates, and across three channels within each sub-band. Special care was used to make sure that the EUT was transmitting in continuous mode. This method exceeds the limitations of FCC KDB-789033, and provides more accurate measurements.

The Maximum conducted output power using KDB 789033 section E)3)b) Method PM-G (Measurement using a gated RF average power meter).

### 3.5. Uncertainty

$\pm 1.27 \text{ dB}$



### 3.6. Test Result of Maximum conducted output power

Product : SpectraGuard® Access Point / Sensor  
 Test Item : Maximum conducted output power  
 Test Site : No.3 OATS  
 Test Mode : Mode 1: Transmit (802.11a-6Mbps)(Dipole Antenna)

#### CHAIN A

Cable loss=1dB		Maximum conducted output power								
Channel No.	Frequency (MHz)	Data Rate (Mbps)								Required Limit
		6	9	12	18	24	36	48	54	
		Measurement Level (dBm)								
36	5180	8.73	--	--	--	--	--	--	--	<17dBm
44	5220	7.42	7.29	7.1	6.95	6.79	6.63	6.47	6.31	<17dBm
48	5240	7.29	--	--	--	--	--	--	--	<17dBm

Note: Maximum conducted output power Value =Reading value on average power meter + cable loss

#### CHAIN B

Cable loss=1dB		Maximum conducted output power								
Channel No.	Frequency (MHz)	Data Rate (Mbps)								Required Limit
		6	9	12	18	24	36	48	54	
		Measurement Level (dBm)								
36	5180	6.33	--	--	--	--	--	--	--	<17dBm
44	5220	6.40	6.29	6.07	5.92	5.76	5.59	5.43	5.26	<17dBm
48	5240	5.29	--	--	--	--	--	--	--	<17dBm

Note: Maximum conducted output power Value =Reading value on average power meter + cable loss

#### CHAIN C

Cable loss=1dB		Maximum conducted output power								
Channel No.	Frequency (MHz)	Data Rate (Mbps)								Required Limit
		6	9	12	18	24	36	48	54	
		Measurement Level (dBm)								
36	5180	8.14	--	--	--	--	--	--	--	<17dBm
44	5220	7.50	7.39	7.27	7.16	7.04	6.93	6.81	6.70	<17dBm
48	5240	7.38	--	--	--	--	--	--	--	<17dBm

Note: Maximum conducted output power Value =Reading value on average power meter + cable loss

**Maximum conducted output power Measurement:**

**(CHAIN A+ B+C)**

Channel Number	Frequency (MHz)	26dB Bandwidth (MHz)	Chain A Power (dBm)	Chain B Power (dBm)	Chain C Power (dBm)	Output Power (dBm)	Output Power Limit	
							(dBm)	dBm+10log(BW)
36	5180	21.850	8.73	6.33	8.14	12.62	17	17.39
44	5220	21.500	7.42	6.40	7.50	11.91	17	17.32
48	5240	21.050	7.29	5.29	7.38	11.53	17	17.23

Note:

1. Power Output Value =Reading value on average power meter + cable loss
2. Output Power (dBm) = 10LOG (Chain A Power (mW)+ Chain B Power (mW) + Chain C Power (mW))
3. 26 dB Bandwidth is the bandwidth of chain A or chain B or chain C whichever is less bandwidth, output power limitation is more stringent.

**26dBc Occupied Bandwidth:**

**Channel 36: CHAIN A**

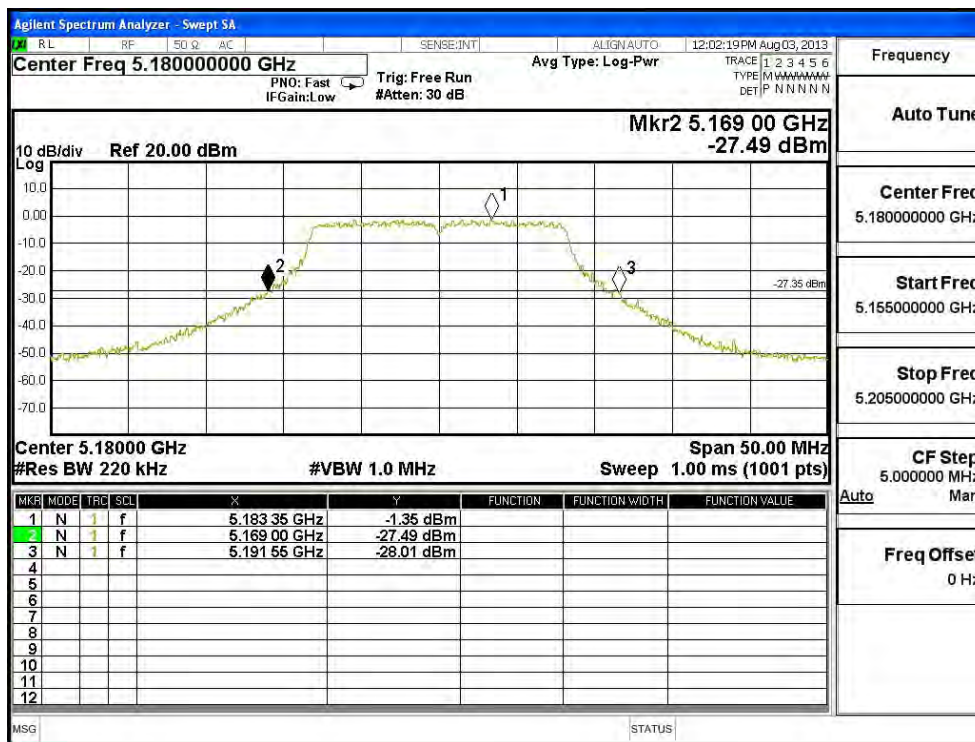

**Channel 44: CHAIN A**

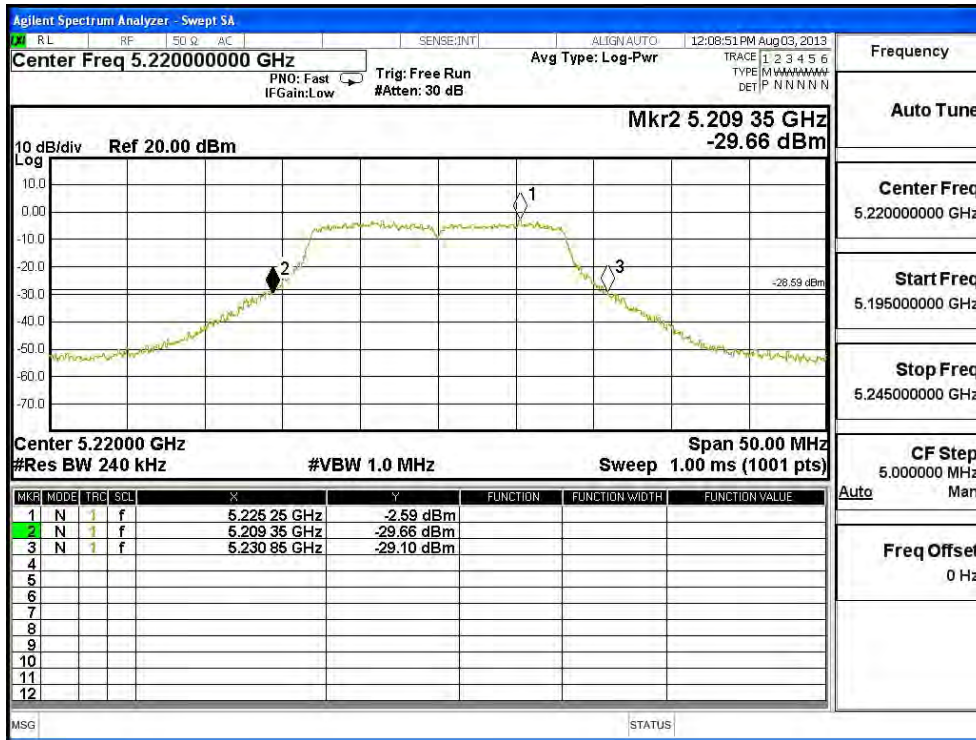

**Channel 48: CHAIN A**

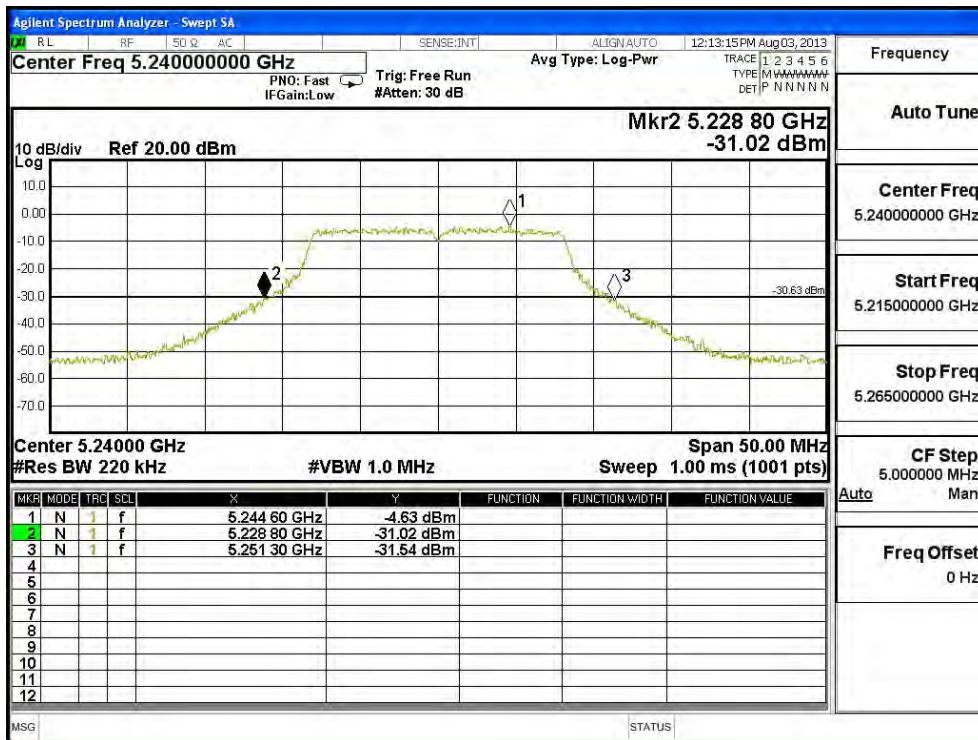

**26dBc Occupied Bandwidth:  
Channel 36: CHAIN B**

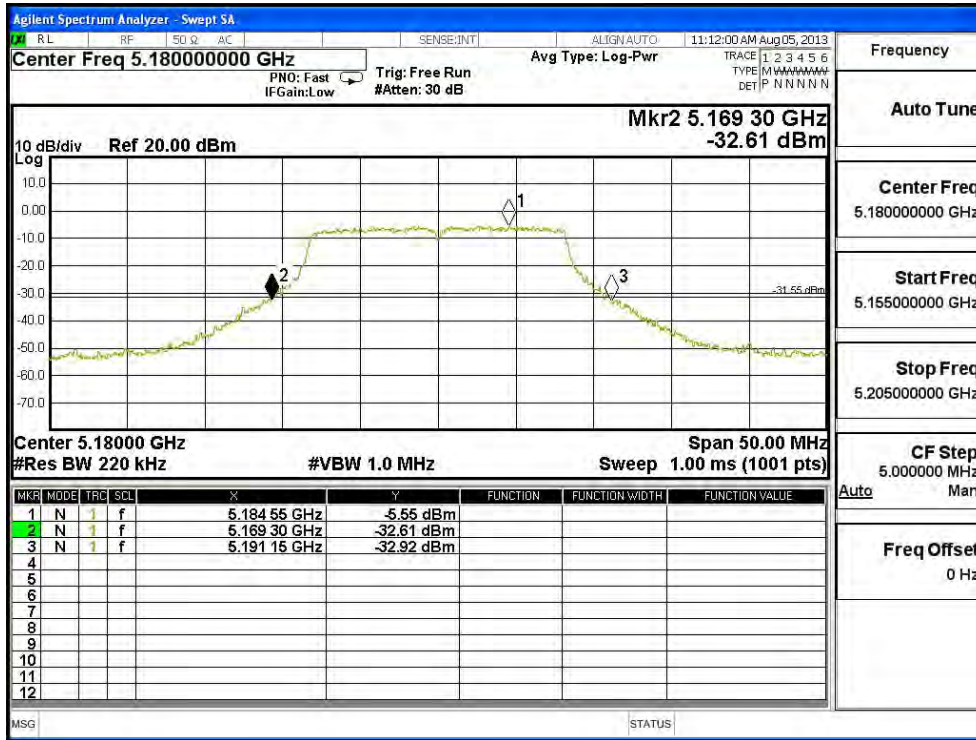

**Channel 44: CHAIN B**

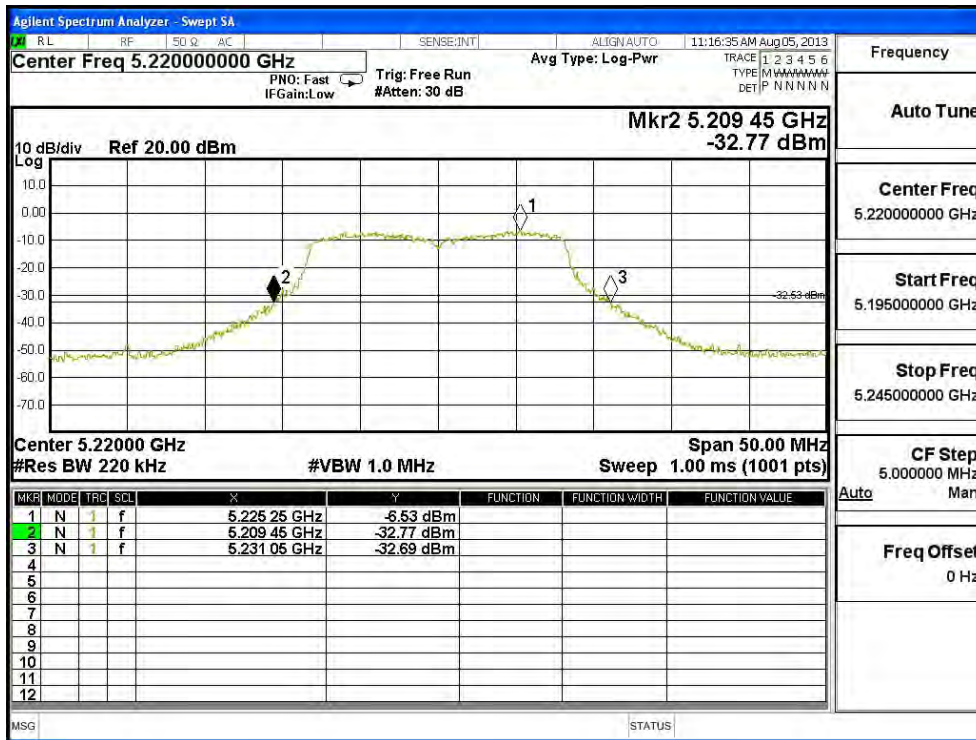

Channel 48: CHAIN B

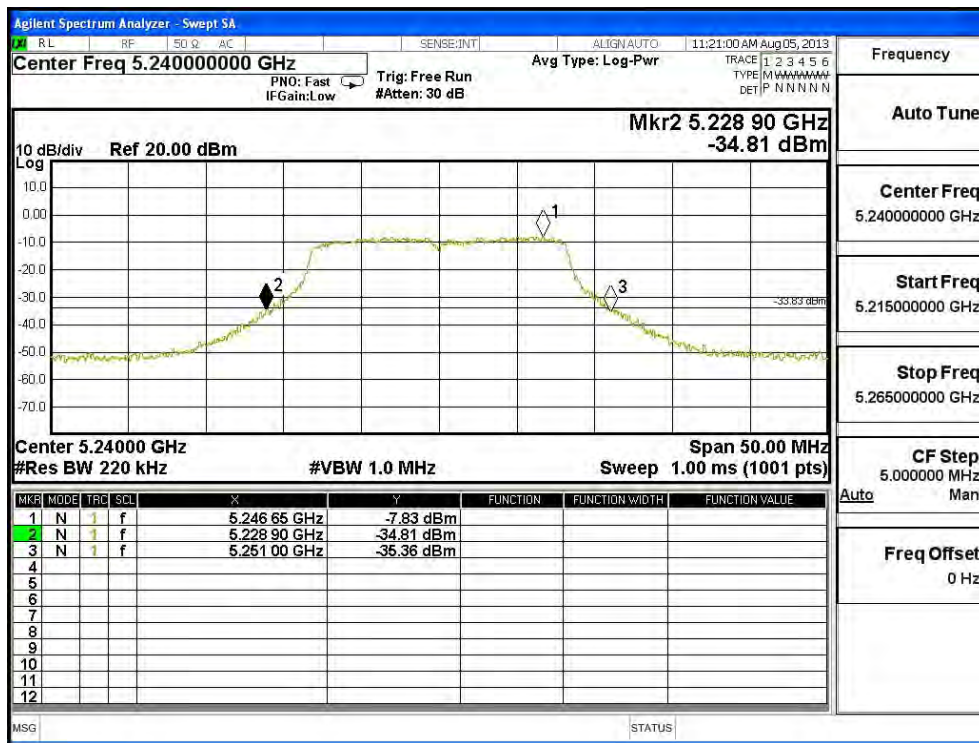

26dBc Occupied Bandwidth:

Channel 36: CHAIN C

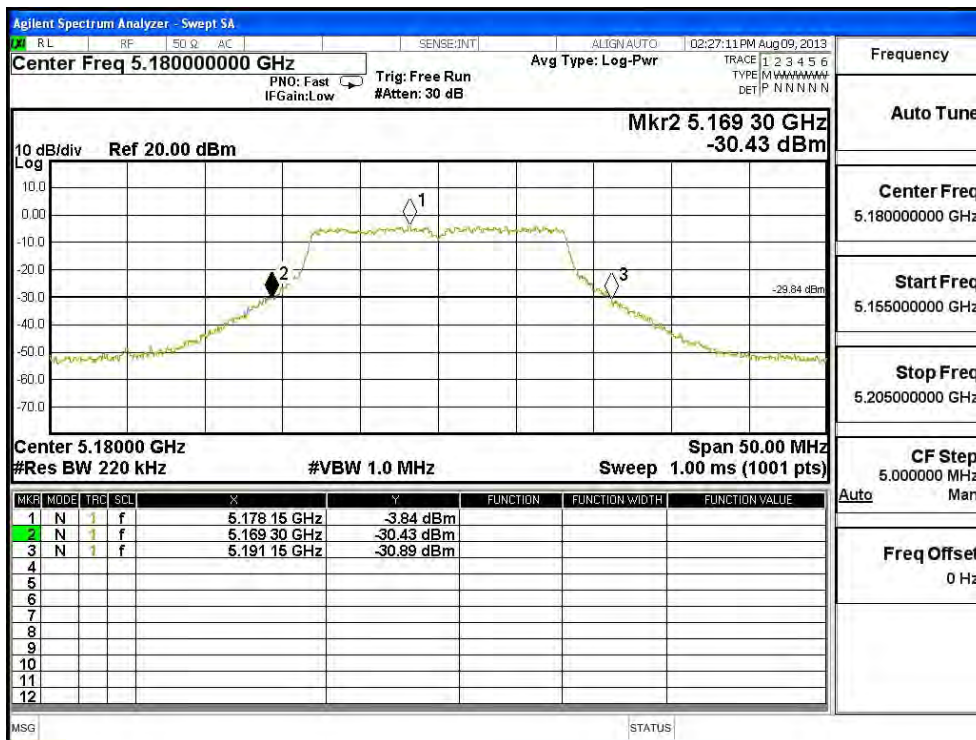

**Channel 44: CHAIN C**

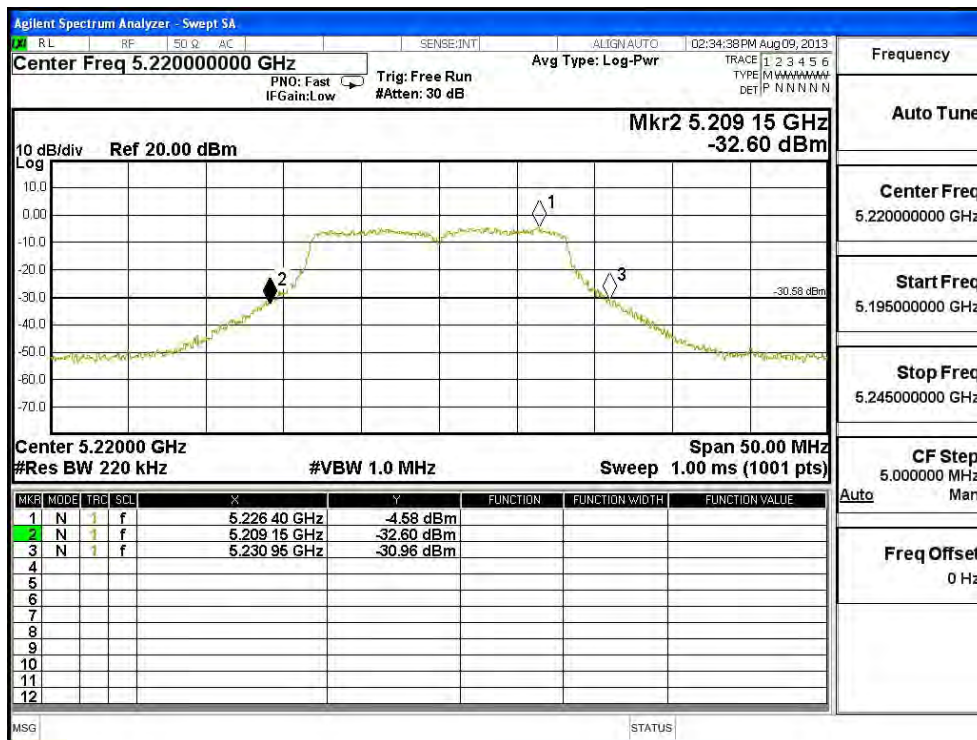

**Channel 48: CHAIN C**

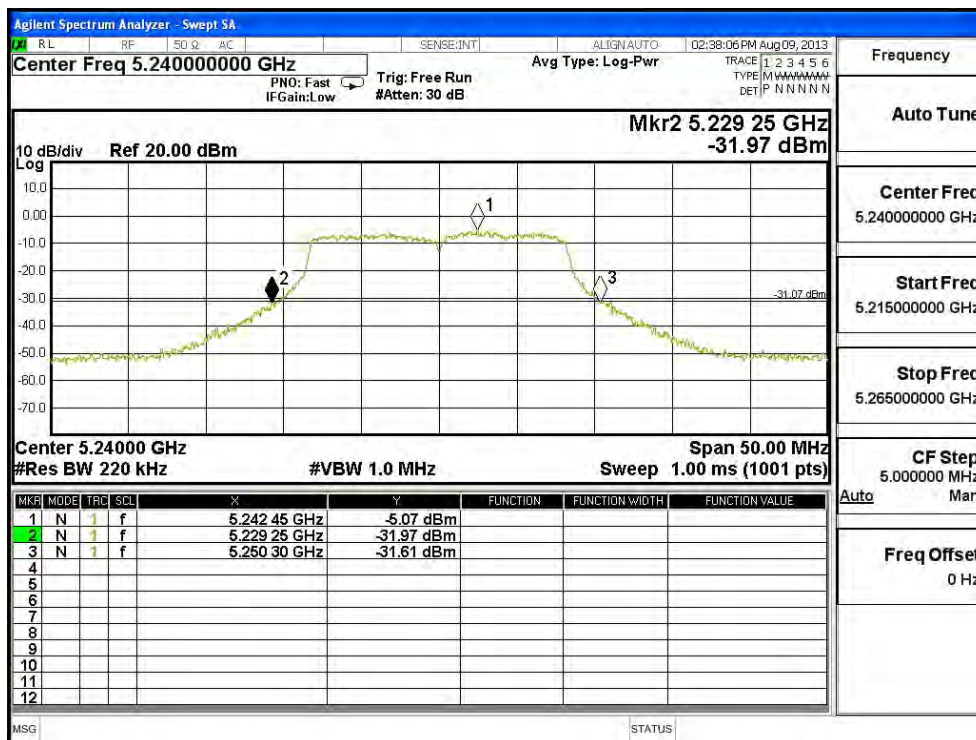

Product : SpectraGuard® Access Point / Sensor  
 Test Item : Maximum conducted output power  
 Test Site : No.3 OATS  
 Test Mode : Mode 2: Transmit (802.11n-20BW 21.7Mbps)(Dipole Antenna)

**CHAIN A**

Cable loss=1dB		Maximum conducted output power								
Channel No.	Frequency (MHz)	Data Rate (Mbps)								Required Limit
		21.7	43.3	65	86.7	130.7	173.3	195	216.7	
		Measurement Level (dBm)								
36	5180	8.36	--	--	--	--	--	--	--	<17dBm
44	5220	8.24	8.1	7.93	7.78	7.63	7.47	7.32	7.16	<17dBm
48	5240	8.19	--	--	--	--	--	--	--	<17dBm

Note: Maximum conducted output power Value =Reading value on average power meter + cable loss

**CHAIN B**

Cable loss=1dB		Maximum conducted output power								
Channel No.	Frequency (MHz)	Data Rate (Mbps)								Required Limit
		21.7	43.3	65	86.7	130.7	173.3	195	216.7	
		Measurement Level (dBm)								
36	5180	6.4	--	--	--	--	--	--	--	<17dBm
44	5220	6.33	6.21	6.06	5.93	5.79	5.66	5.53	5.39	<17dBm
48	5240	6.51	--	--	--	--	--	--	--	<17dBm

Note: Maximum conducted output power Value =Reading value on average power meter + cable loss

**CHAIN C**

Cable loss=1dB		Maximum conducted output power								
Channel No.	Frequency (MHz)	Data Rate (Mbps)								Required Limit
		21.7	43.3	65	86.7	130.7	173.3	195	216.7	
		Measurement Level (dBm)								
36	5180	8.38	--	--	--	--	--	--	--	<17dBm
44	5220	8.71	8.59	8.33	8.16	7.97	7.78	7.59	7.4	<17dBm
48	5240	8.4	--	--	--	--	--	--	--	<17dBm

Note: Maximum conducted output power Value =Reading value on average power meter + cable loss

**Maximum conducted output power Measurement:**

(CHAIN A+ B+C)

Channel Number	Frequency (MHz)	26dB Bandwidth (MHz)	Chain A Power (dBm)	Chain B Power (dBm)	Chain C Power (dBm)	Output Power (dBm)	Output Power Limit	
							(dBm)	dBm+10log(BW)
36	5180	22.300	8.36	6.40	8.38	12.58	17	17.48
44	5220	22.500	8.24	6.33	8.71	12.65	17	17.52
48	5240	22.300	8.19	6.51	8.40	12.55	17	17.48

Note:

1. Power Output Value =Reading value on average power meter + cable loss
2. Output Power (dBm) = 10LOG (Chain A Power (mW)+ Chain B Power (mW) + Chain C Power(mW))
3. 26 dB Bandwidth is the bandwidth of chain A or chain B or chain C whichever is less bandwidth, output power limitation is more stringent.

**26dBc Occupied Bandwidth:**

**Channel 36 -Chain A**

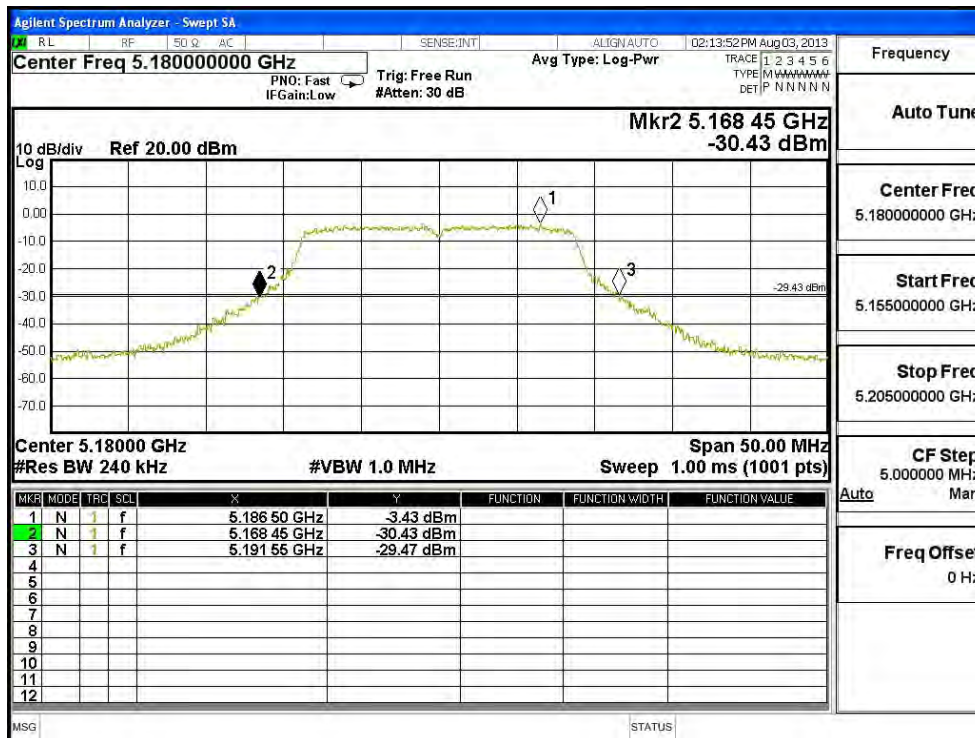



Channel 44 -Chain A

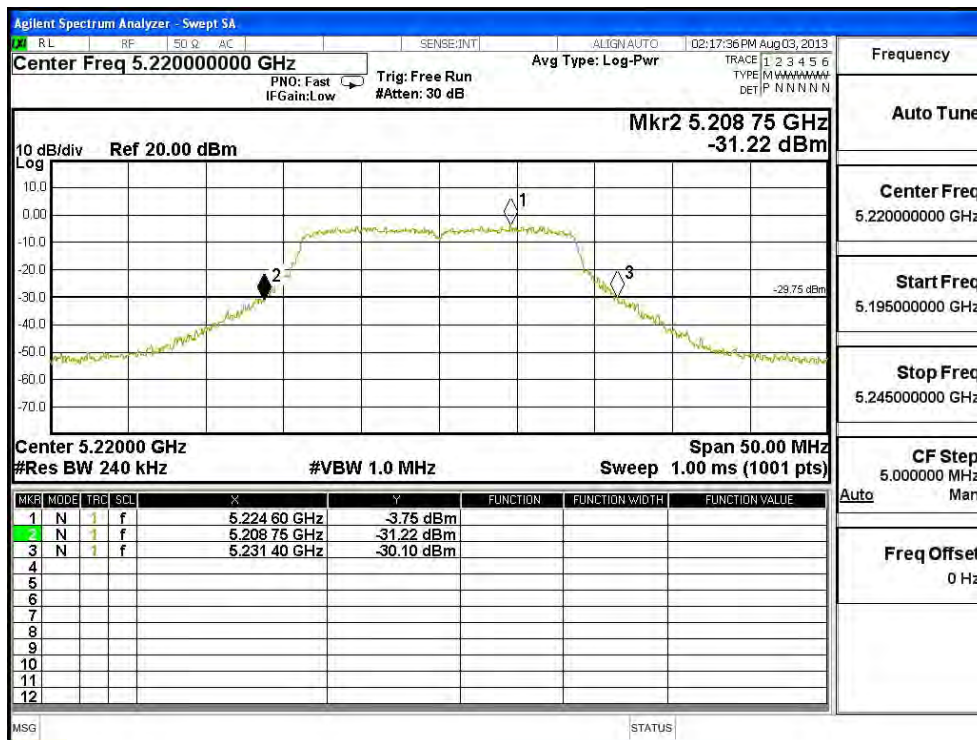

Channel 48 -Chain A

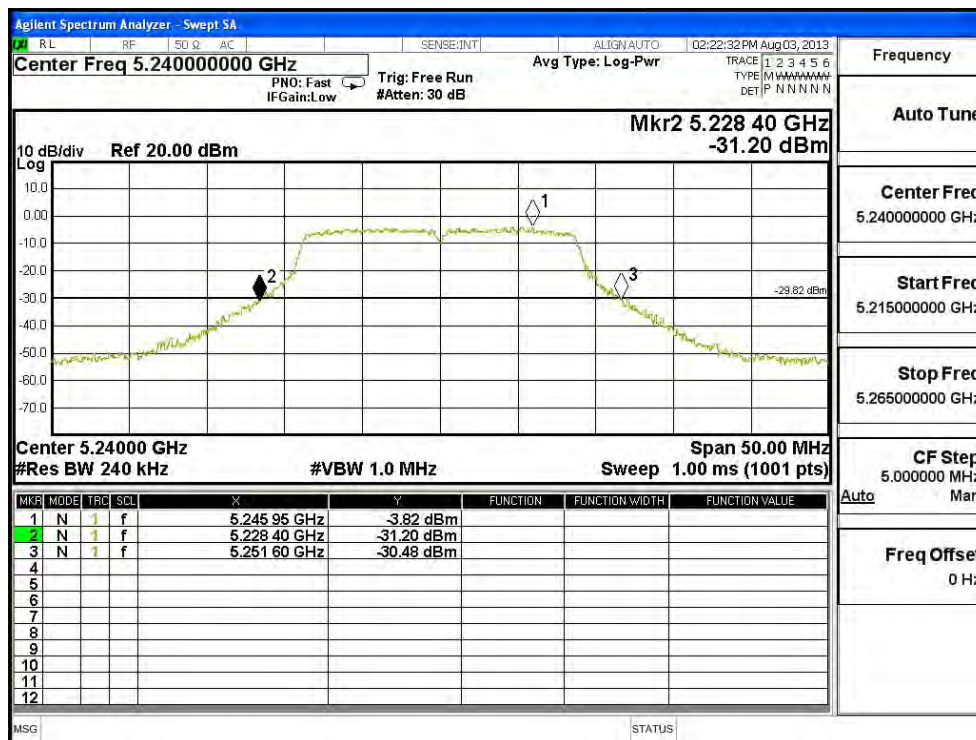

### 26dBc Occupied Bandwidth: Channel 36 -Chain B

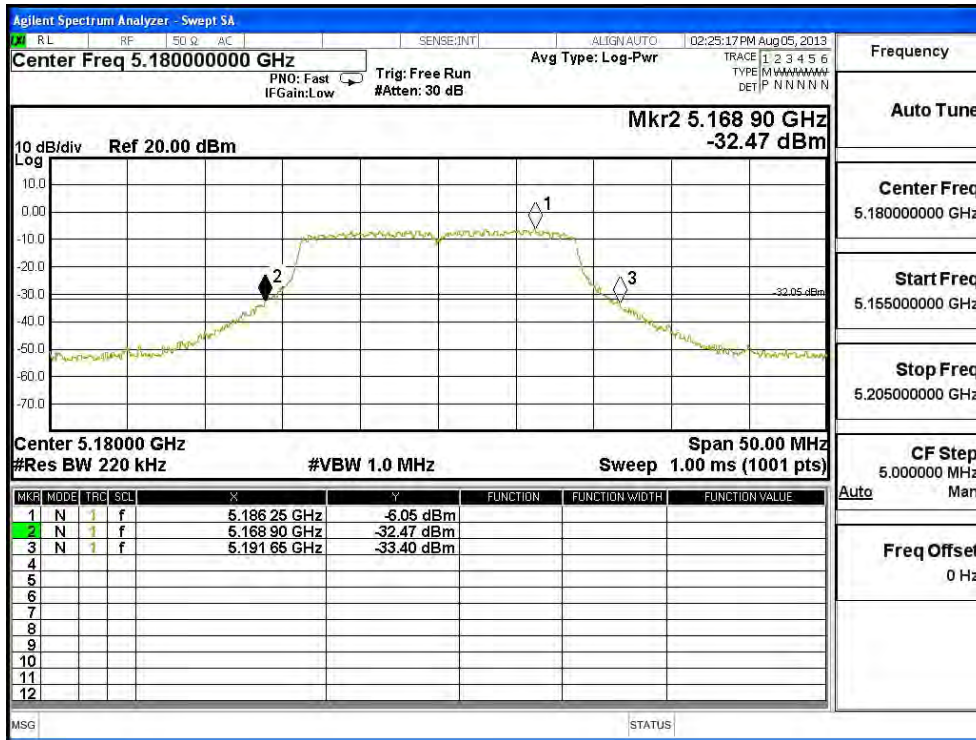

### Channel 44 -Chain B

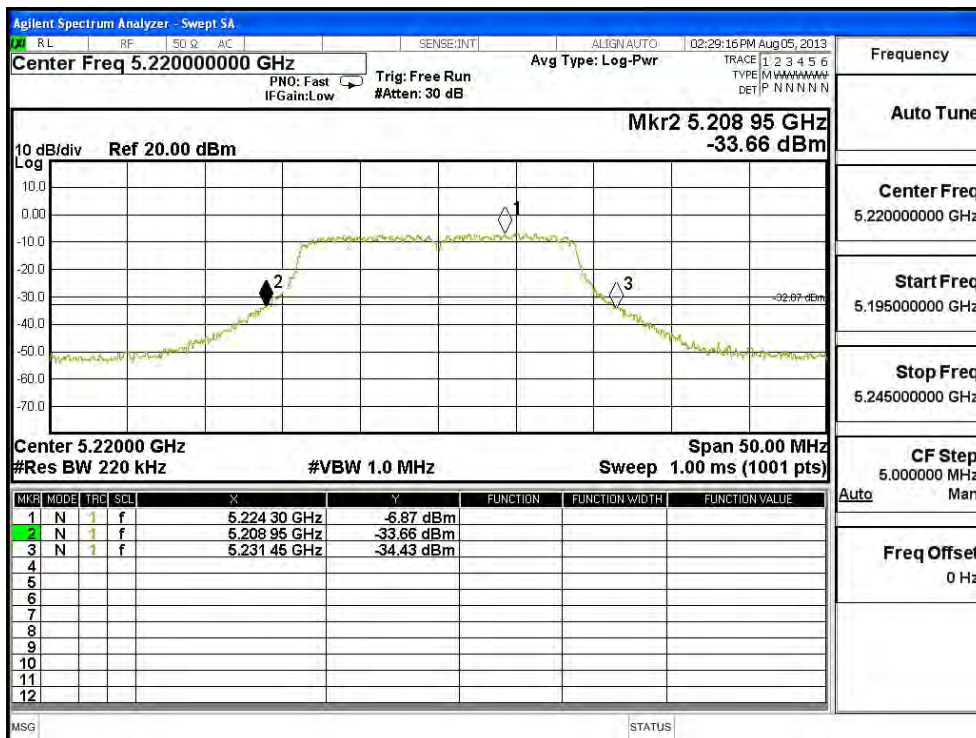

**Channel 48 -Chain B**

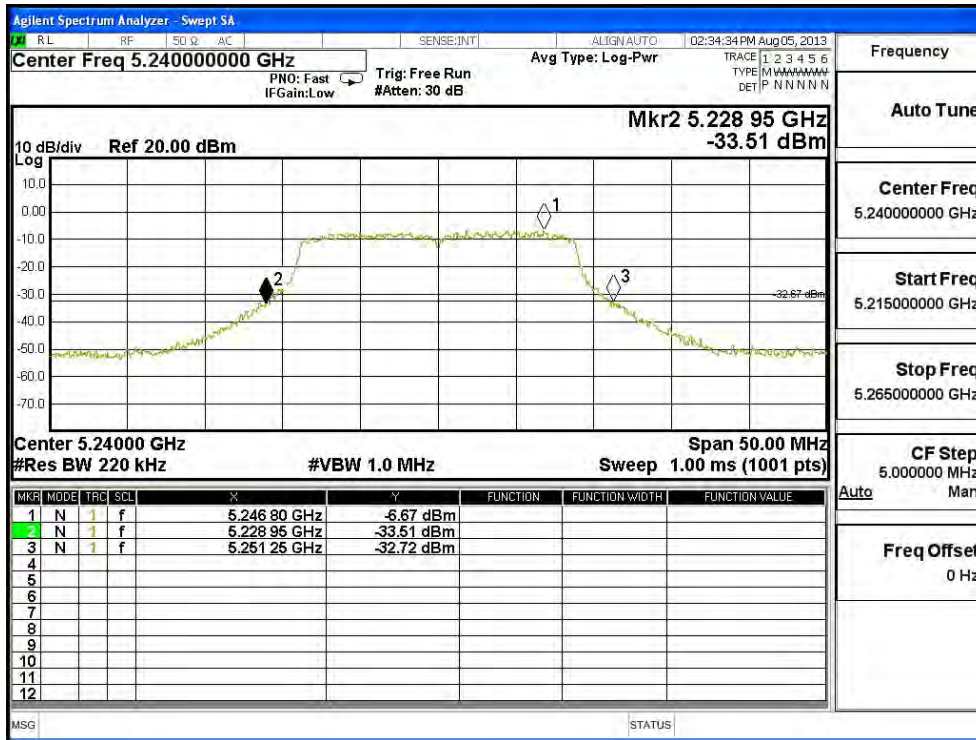

**26dBc Occupied Bandwidth:**

**Channel 36 -Chain C**

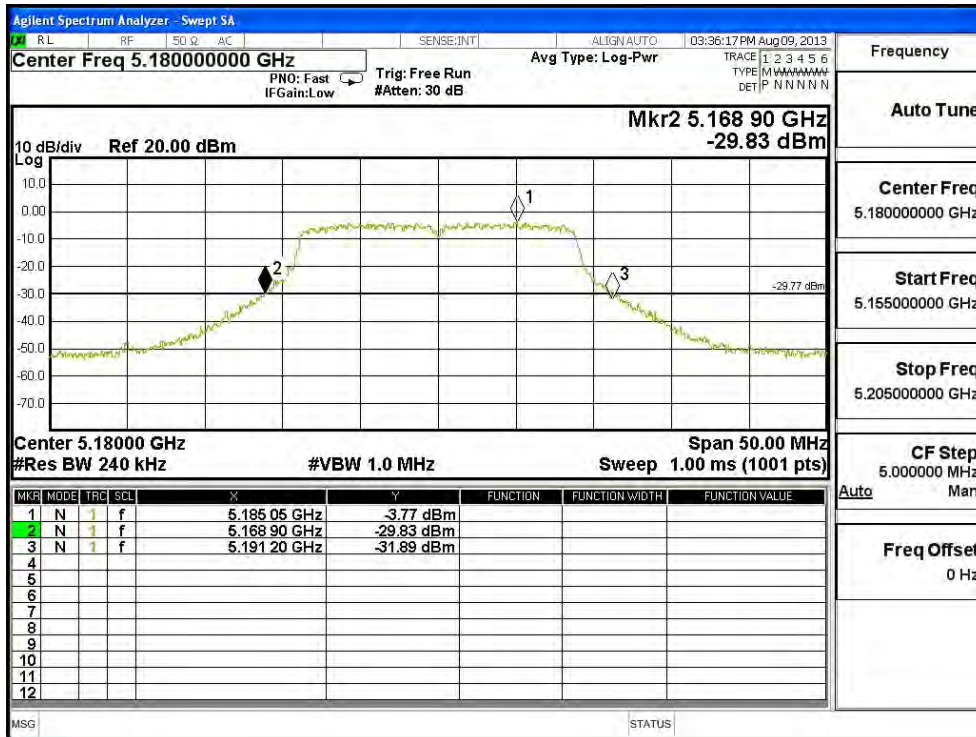

### Channel 44 -Chain C

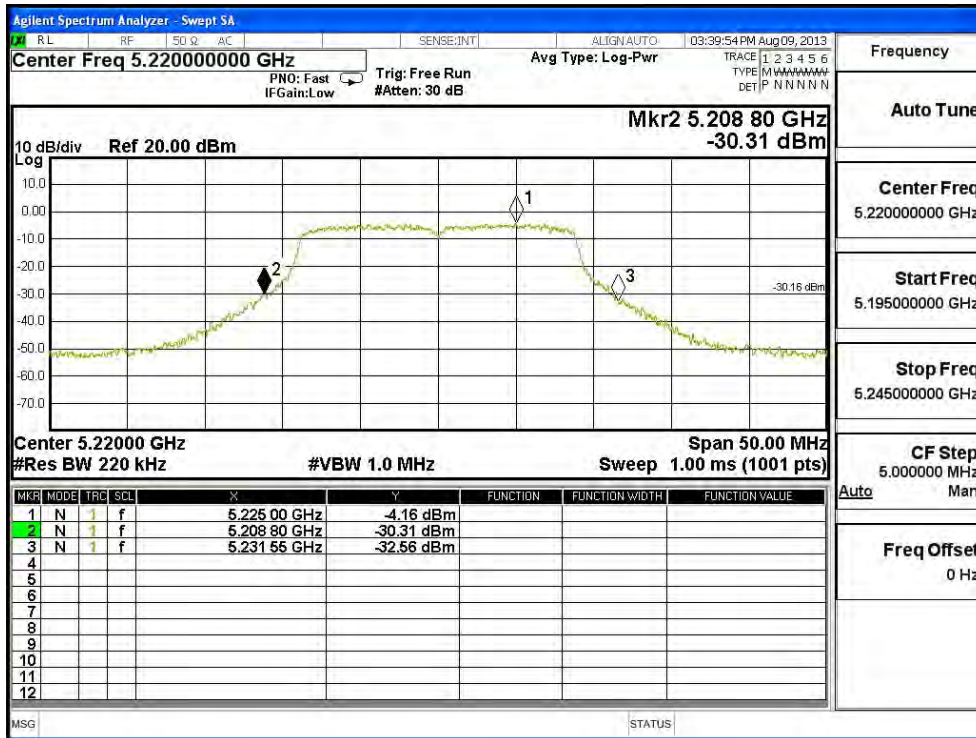

### Channel 48 -Chain C

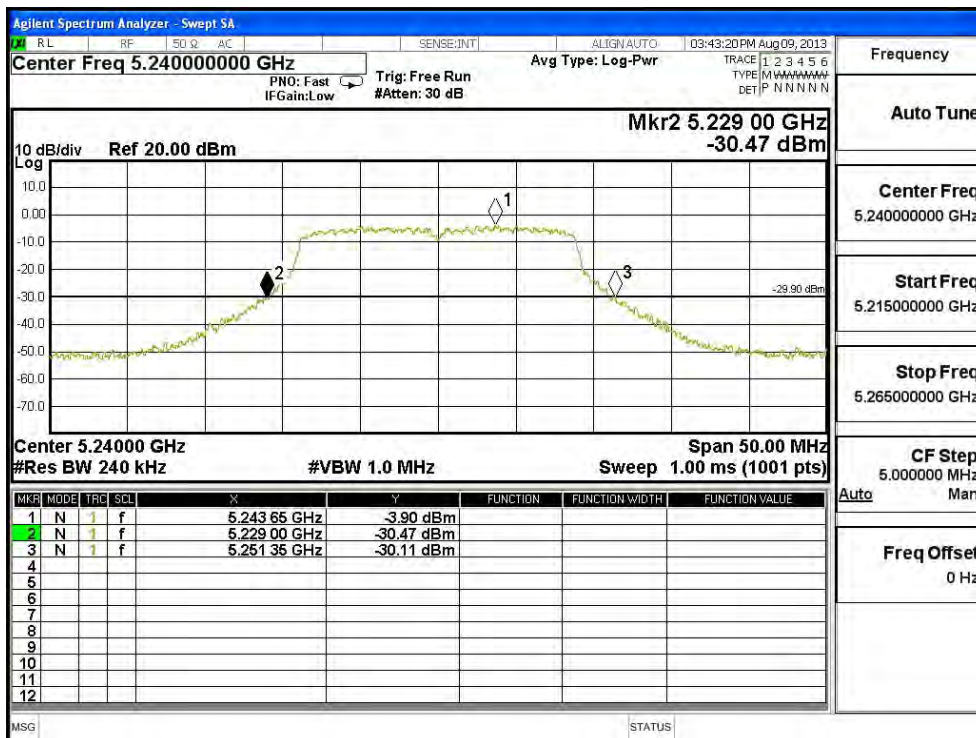

Product : SpectraGuard® Access Point / Sensor  
 Test Item : Maximum conducted output power  
 Test Site : No.3 OATS  
 Test Mode : Mode 3: Transmit (802.11n-40BW 45Mbps)(Dipole Antenna)

**CHAIN A**

Cable loss=1dB		Maximum conducted output power								
Channel No.	Frequency (MHz)	Data Rate (Mbps)								Required Limit
		45	90	135	180	270	360	405	450	
		Measurement Level (dBm)								
38	5190	8.46	--	--	--	--	--	--	--	<17dBm
46	5230	8.18	8.07	7.84	7.69	7.52	7.35	7.18	7.01	<17dBm

Note: Maximum conducted output power Value =Reading value on average power meter + cable loss

**CHAIN B**

Cable loss=1dB		Maximum conducted output power								
Channel No.	Frequency (MHz)	Data Rate (Mbps)								Required Limit
		45	90	135	180	270	360	405	450	
		Measurement Level (dBm)								
38	5190	7.1	--	--	--	--	--	--	--	<17dBm
46	5230	7.05	6.89	6.64	6.45	6.25	6.04	5.84	5.63	<17dBm

Note: Maximum conducted output power Value =Reading value on average power meter + cable loss

**CHAIN C**

Cable loss=1dB		Maximum conducted output power								
Channel No.	Frequency (MHz)	Data Rate (Mbps)								Required Limit
		45	90	135	180	270	360	405	450	
		Measurement Level (dBm)								
38	5190	8.72	--	--	--	--	--	--	--	<17dBm
46	5230	9.45	9.27	9.04	8.84	8.64	8.43	8.23	8.02	<17dBm

Note: Maximum conducted output power Value =Reading value on average power meter + cable loss

**Maximum conducted output power Measurement:**
**(CHAIN A+ B+C)**

Channel Number	Frequency (MHz)	26dB Bandwidth (MHz)	Chain A Power (dBm)	Chain B Power (dBm)	Chain C Power (dBm)	Output Power (dBm)	Output Power Limit	
							(dBm)	dBm+10log(BW)
38	5190	43.300	8.46	7.10	8.72	12.92	17	20.36
46	5230	43.700	8.18	7.05	9.45	13.11	17	20.40

Note:

1. Power Output Value =Reading value on average power meter + cable loss
2. Output Power (dBm) = 10LOG (Chain A Power (mW)+ Chain B Power (mW) + Chain C Power (mW))
3. 26 dB Bandwidth is the bandwidth of chain A or chain B or chain C whichever is less bandwidth, output power limitation is more stringent.

**26dBc Occupied Bandwidth:  
Channel 38 – Chain A**

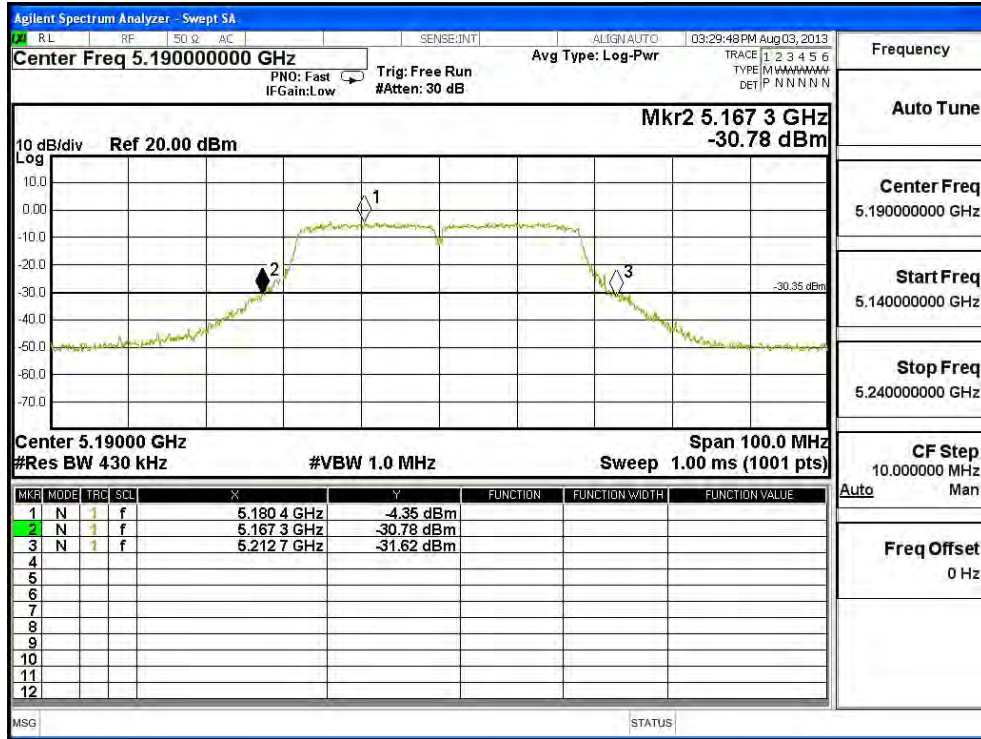

**Channel 46 – Chain A**

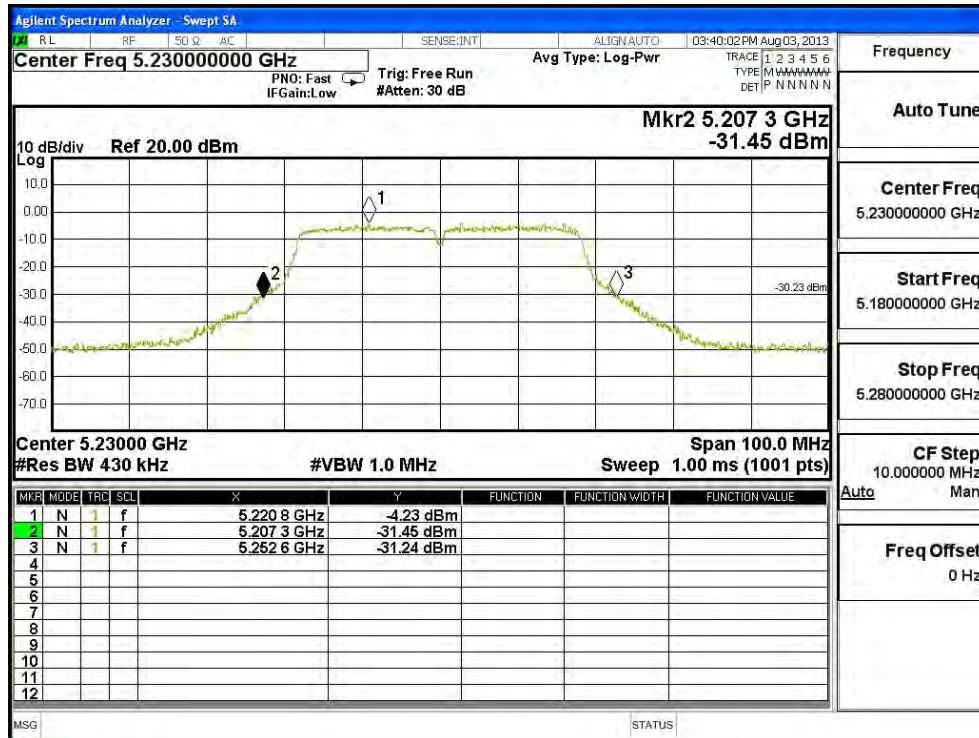

### 26dBc Occupied Bandwidth: Channel 38 – Chain B

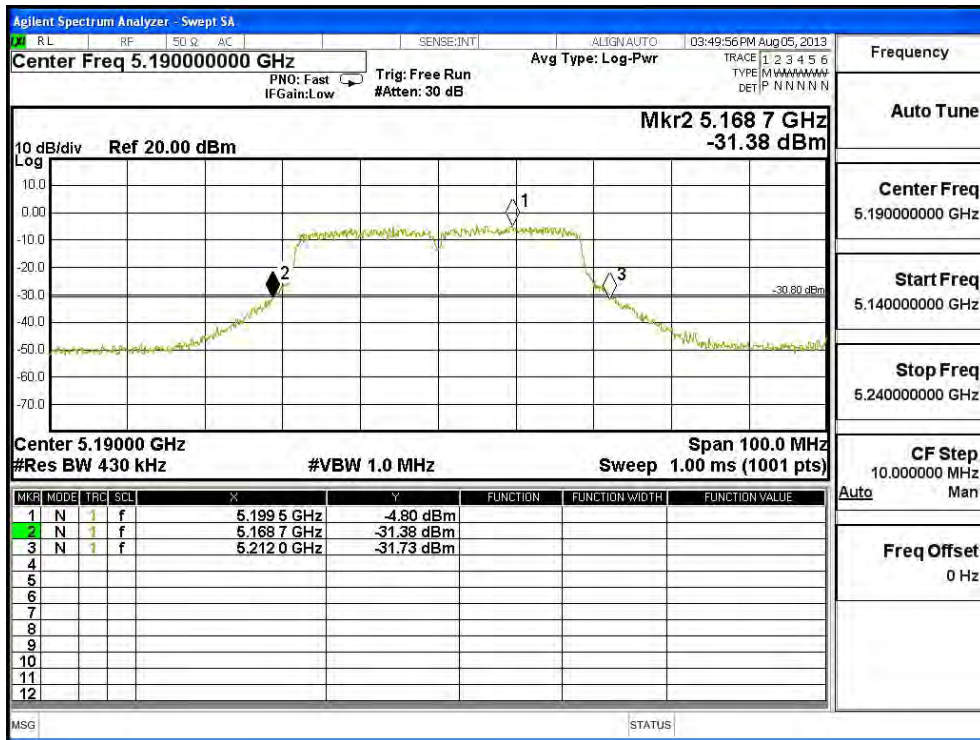

### Channel 46 – Chain B

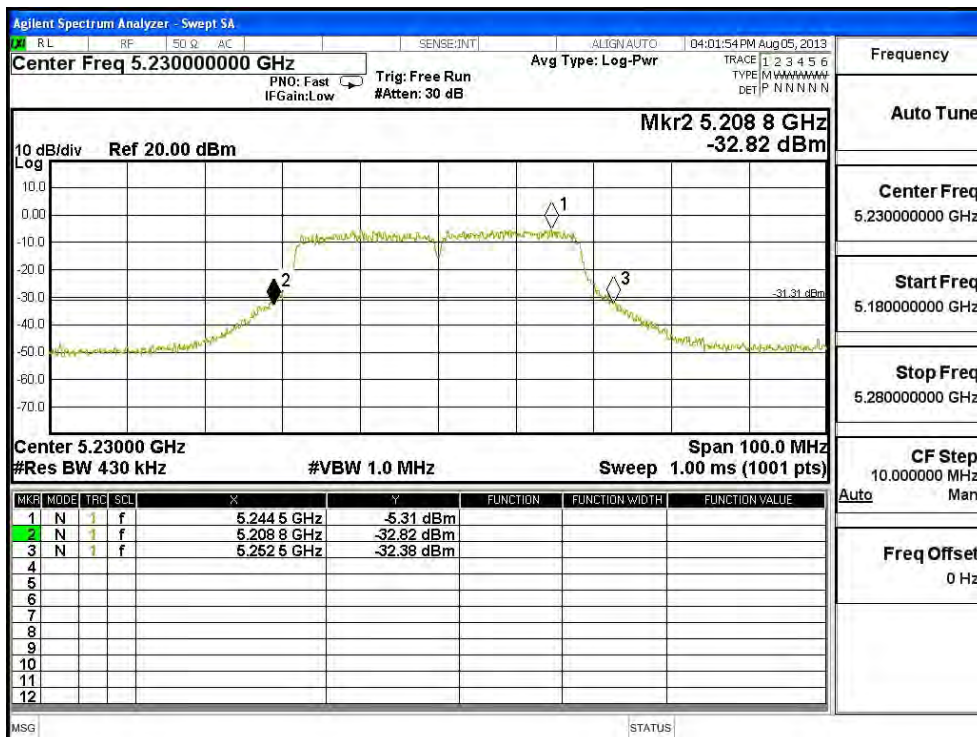



### 26dBc Occupied Bandwidth: Channel 38 – Chain C

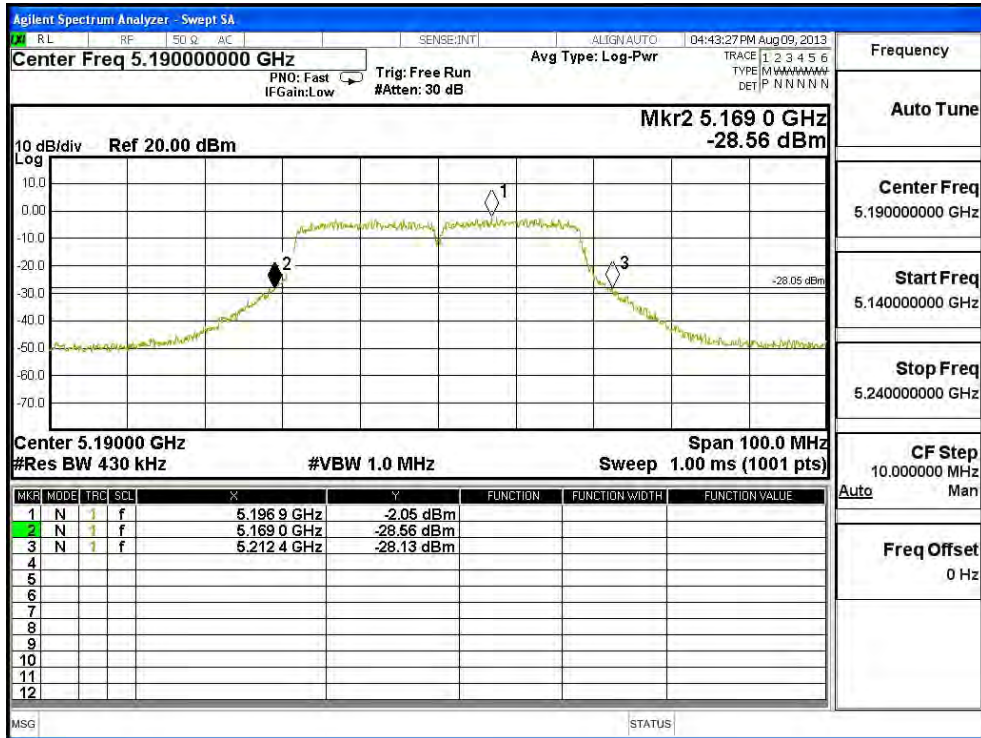

### Channel 46 – Chain C

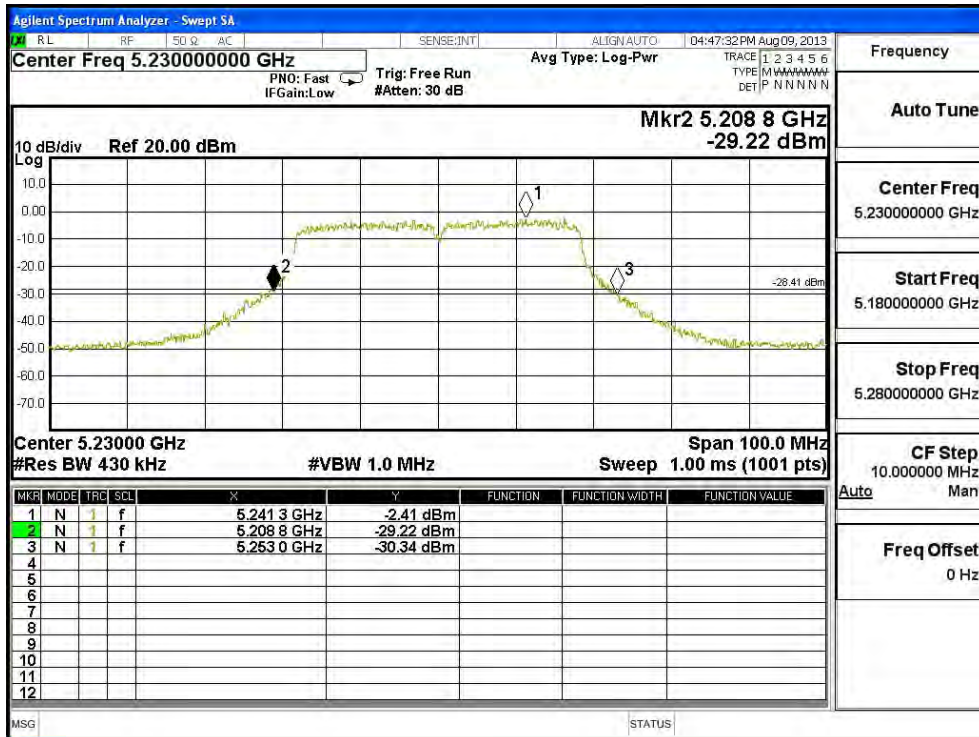

Product : SpectraGuard® Access Point / Sensor  
 Test Item : Maximum conducted output power  
 Test Site : No.3 OATS  
 Test Mode : Mode 4: Transmit (802.11a-6Mbps)(PIFA Antenna)

**CHAIN A**

Cable loss=1dB		Maximum conducted output power								
Channel No.	Frequency (MHz)	Data Rate (Mbps)								Required Limit
		6	9	12	18	24	36	48	54	
		Measurement Level (dBm)								
36	5180	11.33	--	--	--	--	--	--	--	<17dBm
44	5220	11.24	11.11	10.97	10.84	10.70	10.57	10.43	10.30	<17dBm
48	5240	11.48	--	--	--	--	--	--	--	<17dBm

Note: Maximum conducted output power Value =Reading value on average power meter + cable loss

**CHAIN B**

Cable loss=1dB		Maximum conducted output power								
Channel No.	Frequency (MHz)	Data Rate (Mbps)								Required Limit
		6	9	12	18	24	36	48	54	
		Measurement Level (dBm)								
36	5180	11.03	--	--	--	--	--	--	--	<17dBm
44	5220	11.12	11.01	10.89	10.78	10.66	10.55	10.43	10.32	<17dBm
48	5240	11.02	--	--	--	--	--	--	--	<17dBm

Note: Maximum conducted output power Value =Reading value on average power meter + cable loss

**CHAIN C**

Cable loss=1dB		Maximum conducted output power								
Channel No.	Frequency (MHz)	Data Rate (Mbps)								Required Limit
		6	9	12	18	24	36	48	54	
		Measurement Level (dBm)								
36	5180	11.4	--	--	--	--	--	--	--	<17dBm
44	5220	11.55	11.41	11.29	11.16	11.03	10.90	10.77	10.64	<17dBm
48	5240	11.71	--	--	--	--	--	--	--	<17dBm

Note: Maximum conducted output power Value =Reading value on average power meter + cable loss

**Maximum conducted output power Measurement:**

(CHAIN A+ B+C)

Channel Number	Frequency (MHz)	26dB Bandwidth (MHz)	Chain A Power (dBm)	Chain B Power (dBm)	Chain C Power (dBm)	Output Power (dBm)	Output Power Limit	
							(dBm)	dBm+10log(BW)
36	5180	23.300	11.33	11.03	11.40	16.03	17	17.67
44	5220	23.050	11.24	11.12	11.55	16.08	17	17.63
48	5240	22.600	11.48	11.02	11.71	16.18	17	17.54

Note:

- Power Output Value =Reading value on average power meter + cable loss
- Output Power (dBm) = 10LOG (Chain A Power (mW)+ Chain B Power (mW) + Chain C Power (mW))
- 26 dB Bandwidth is the bandwidth of chain A or chain B or chain C whichever is less bandwidth, output power limitation is more stringent.

**26dBc Occupied Bandwidth:**

**Channel 36: CHAIN A**

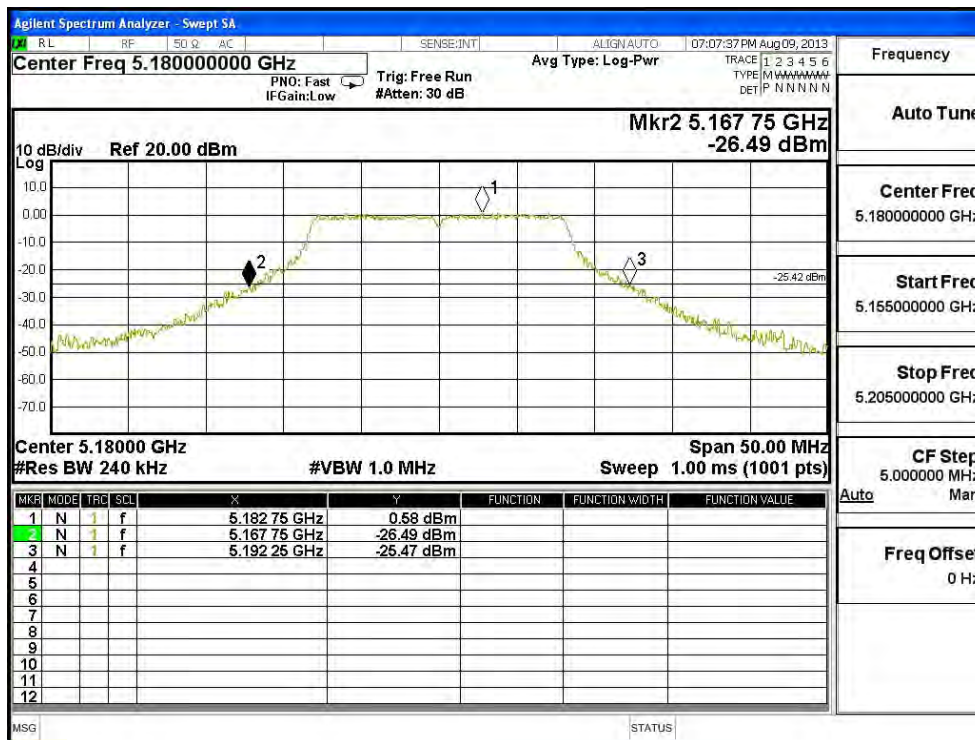

**Channel 40: CHAIN A**

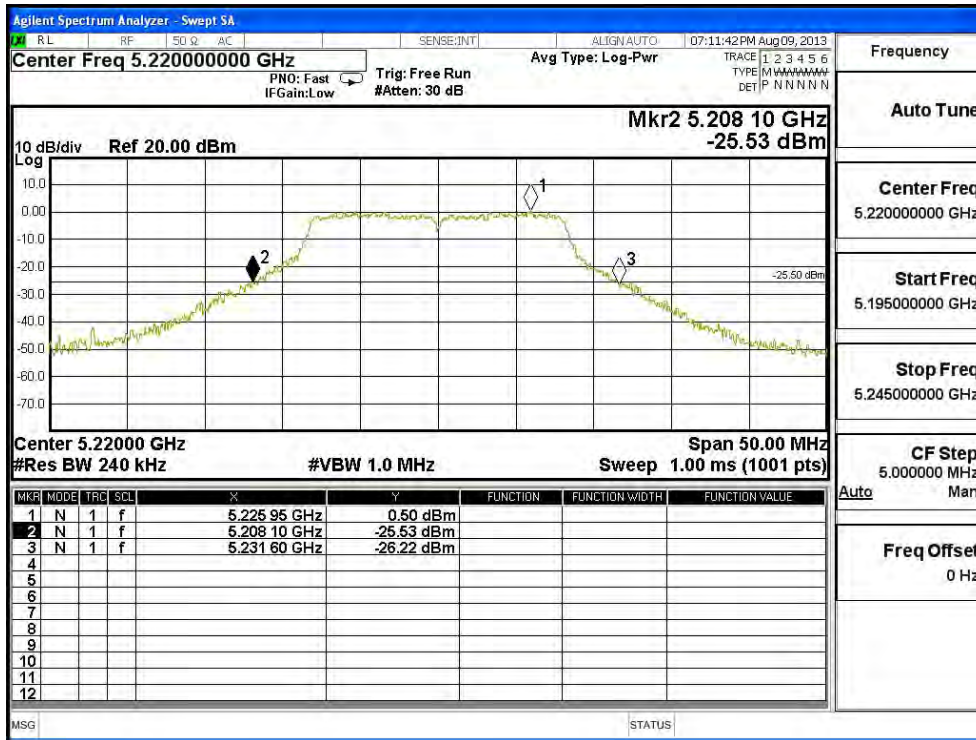

**Channel 48: CHAIN A**

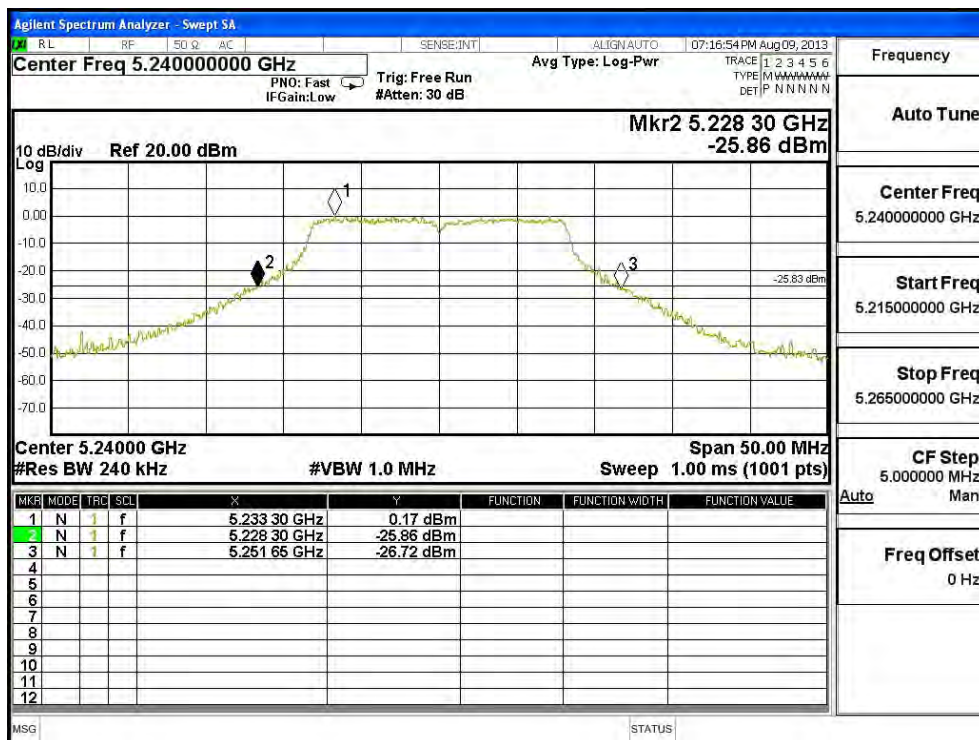

**26dBc Occupied Bandwidth:  
Channel 36: CHAIN B**

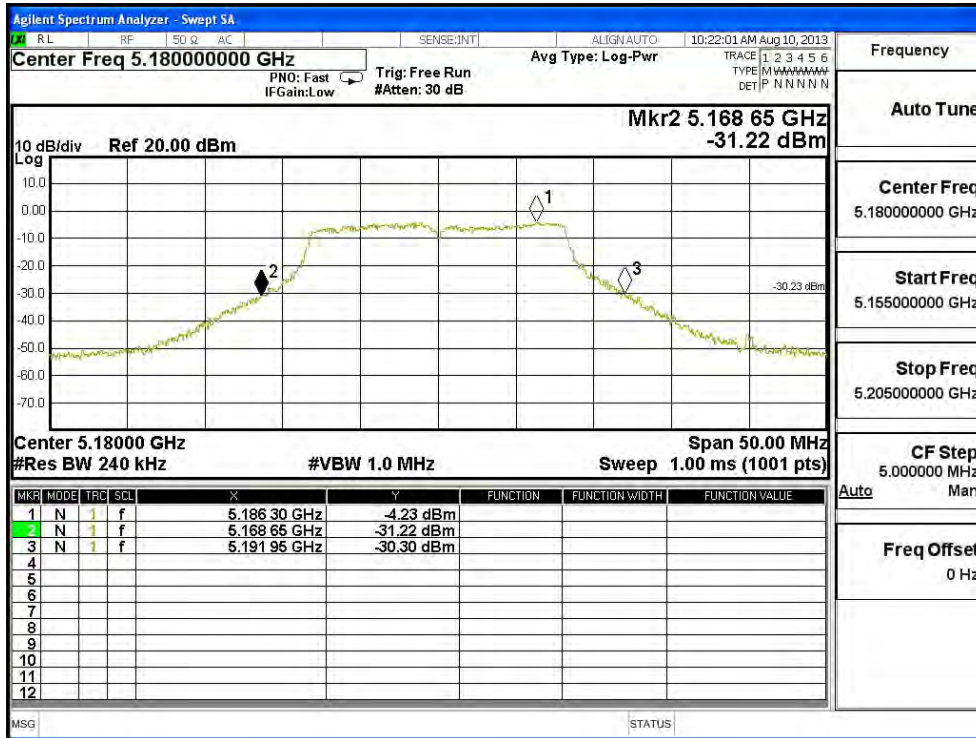

**Channel 40: CHAIN B**

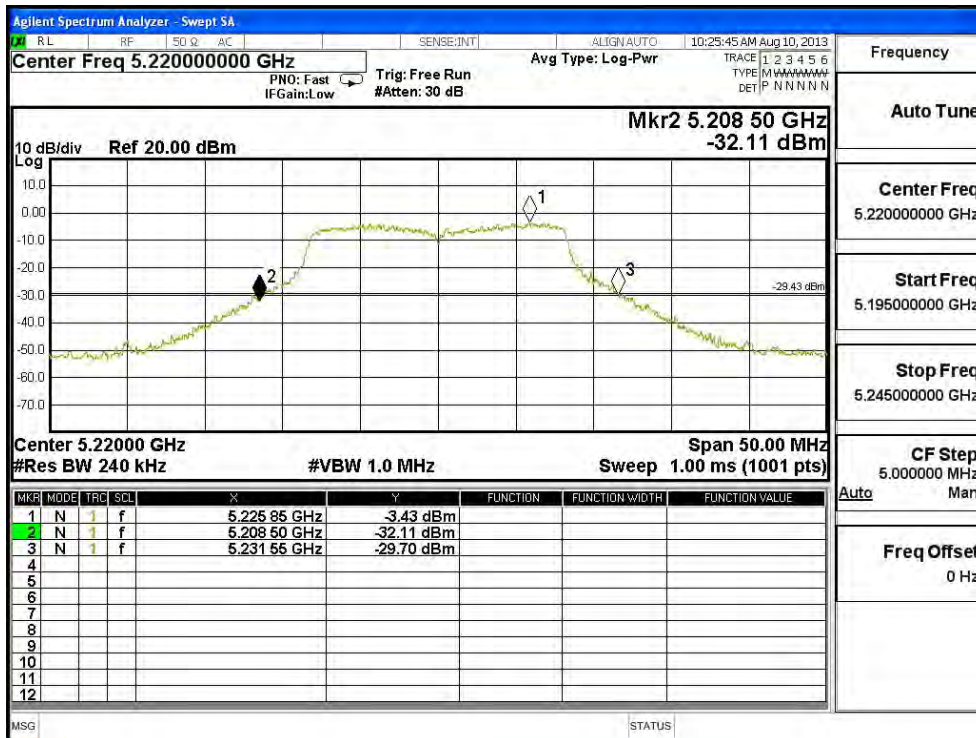

**Channel 48: CHAIN B**

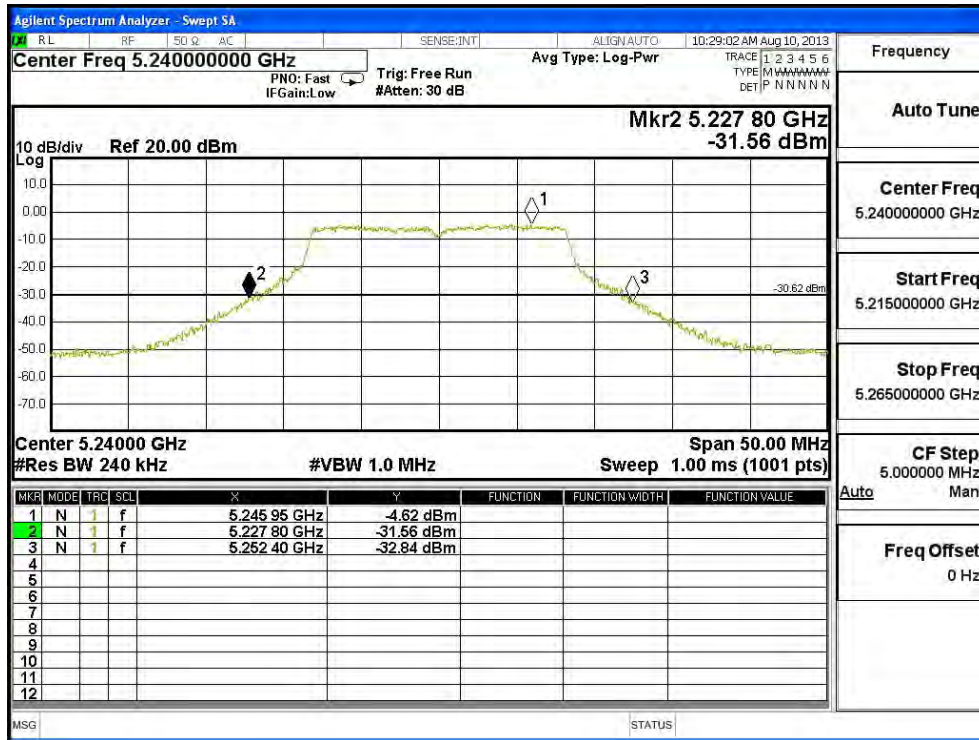

**26dBc Occupied Bandwidth:  
Channel 36: CHAIN C**

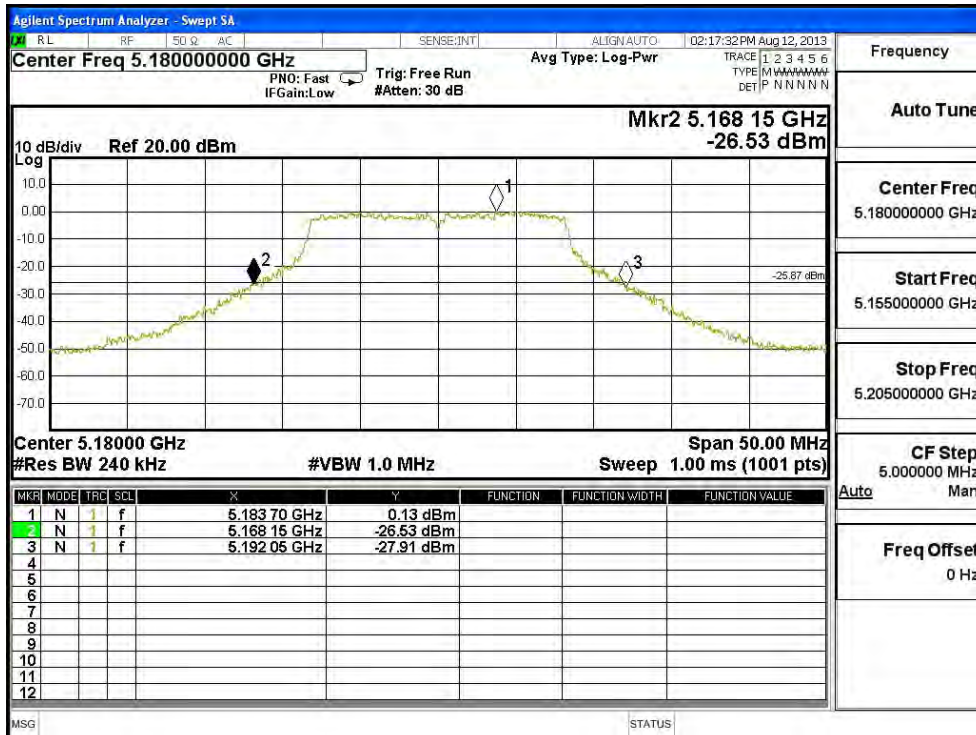

### Channel 40: CHAIN C

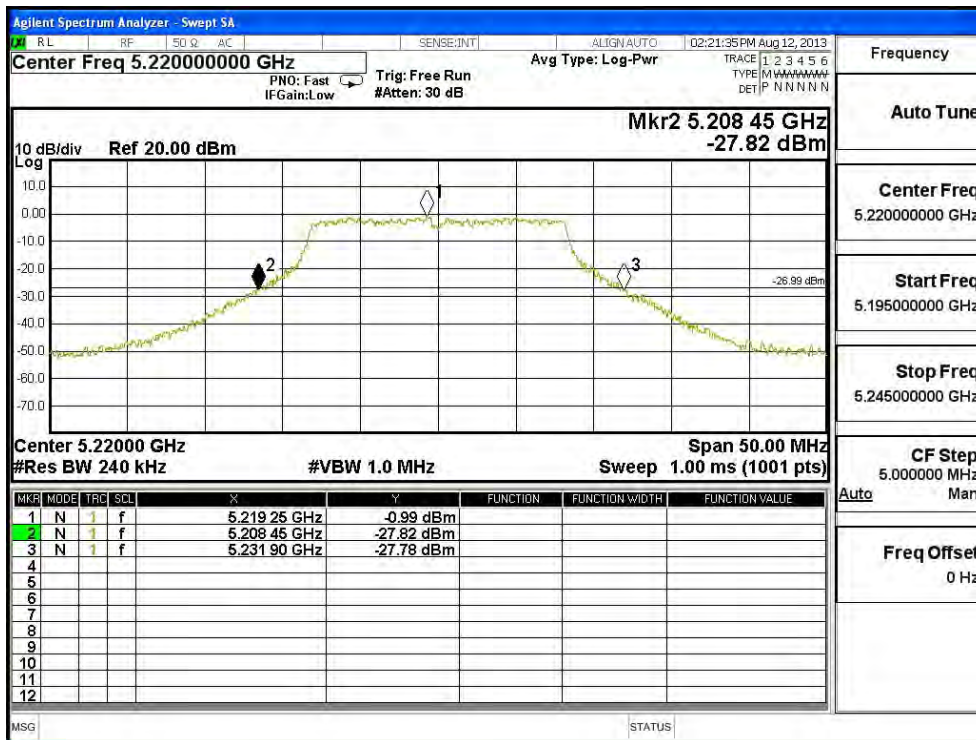

### Channel 48: CHAIN C

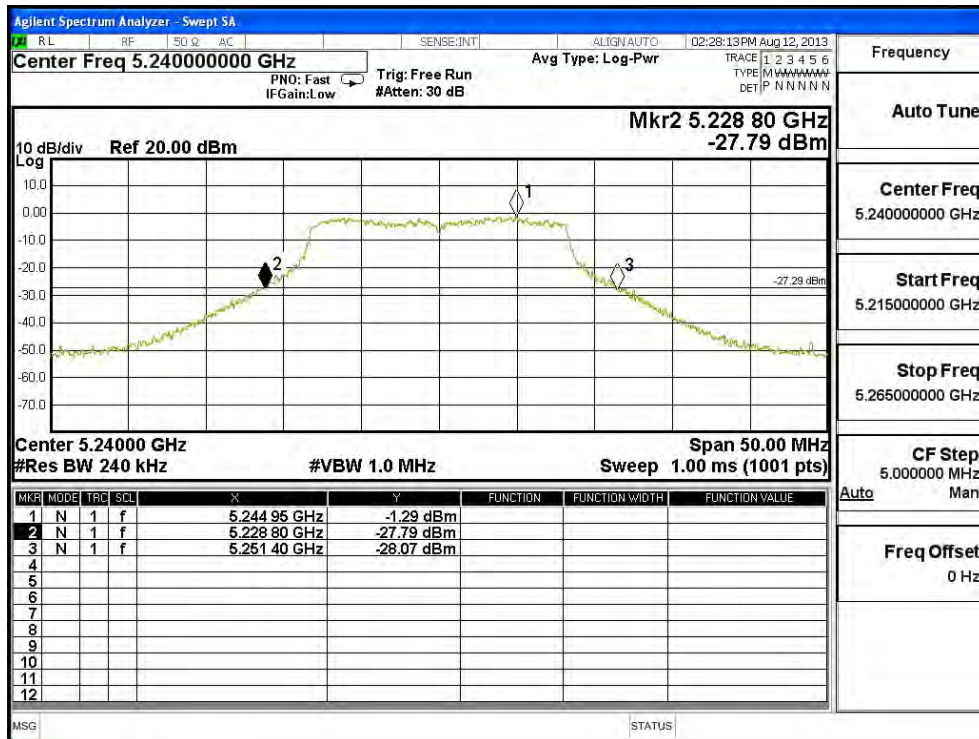

Product : SpectraGuard® Access Point / Sensor  
 Test Item : Maximum conducted output power  
 Test Site : No.3 OATS  
 Test Mode : Mode 5: Transmit (802.11n-20BW 21.7Mbps)(PIFA Antenna)

**CHAIN A**

Cable loss=1dB		Maximum conducted output power								
Channel No.	Frequency (MHz)	Data Rate (Mbps)								Required Limit
		21.7	43.3	65	86.7	130.7	173.3	195	216.7	
		Measurement Level (dBm)								
36	5180	11.04	--	--	--	--	--	--	--	<17dBm
44	5220	11.21	11.1	10.98	10.87	10.75	10.64	10.52	10.41	<17dBm
48	5240	11.47	--	--	--	--	--	--	--	<17dBm

Note: Maximum conducted output power Value =Reading value on average power meter + cable loss

**CHAIN B**

Cable loss=1dB		Maximum conducted output power								
Channel No.	Frequency (MHz)	Data Rate (Mbps)								Required Limit
		21.7	43.3	65	86.7	130.7	173.3	195	216.7	
		Measurement Level (dBm)								
36	5180	11.42	--	--	--	--	--	--	--	<17dBm
44	5220	10.79	10.66	10.51	10.37	10.23	10.09	9.95	9.81	<17dBm
48	5240	10.81	--	--	--	--	--	--	--	<17dBm

Note: Maximum conducted output power Value =Reading value on average power meter + cable loss

**CHAIN C**

Cable loss=1dB		Maximum conducted output power								
Channel No.	Frequency (MHz)	Data Rate (Mbps)								Required Limit
		21.7	43.3	65	86.7	130.7	173.3	195	216.7	
		Measurement Level (dBm)								
36	5180	12.21	--	--	--	--	--	--	--	<17dBm
44	5220	11.50	11.38	11.2	11.06	10.91	10.76	10.61	10.46	<17dBm
48	5240	11.47	--	--	--	--	--	--	--	<17dBm

Note: Maximum conducted output power Value =Reading value on average power meter + cable loss



**Maximum conducted output power Measurement:**

(CHAIN A+ B+C)

Channel Number	Frequency (MHz)	26dB Bandwidth (MHz)	Chain A Power (dBm)	Chain B Power (dBm)	Chain C Power (dBm)	Output Power (dBm)	Output Power Limit	
							(dBm)	dBm+10log(BW)
36	5180	23.750	11.04	11.42	12.21	16.36	17	17.76
44	5220	23.800	11.21	10.79	11.50	15.95	17	17.77
48	5240	24.400	11.47	10.81	11.47	16.03	17	17.87

Note:

1. Power Output Value =Reading value on average power meter + cable loss
2. Output Power (dBm) = 10LOG (Chain A Power (mW)+ Chain B Power (mW) + Chain C Power(mW))
3. 26 dB Bandwidth is the bandwidth of chain A or chain B or chain C whichever is less bandwidth, output power limitation is more stringent.

**26dBc Occupied Bandwidth:**

**Channel 36 -Chain A**

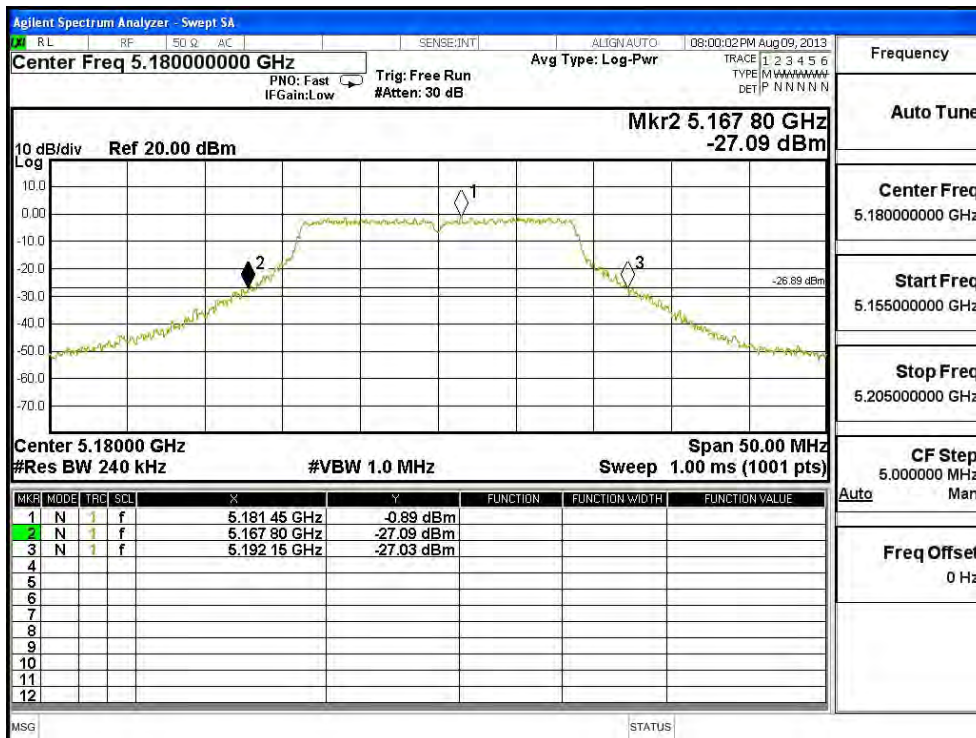

Channel 44 -Chain A

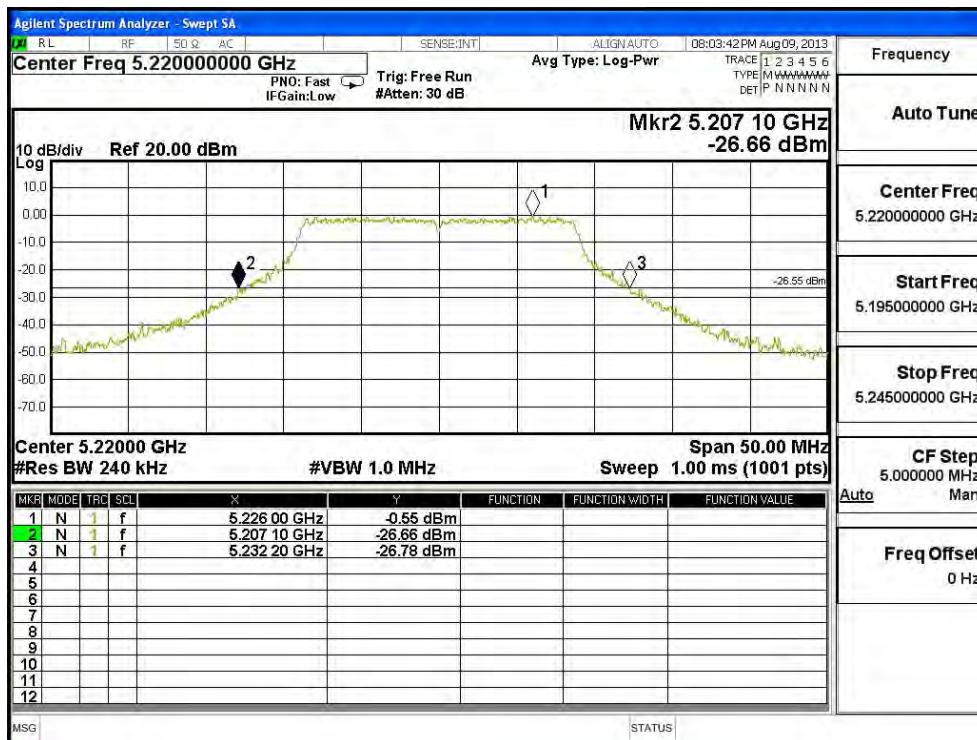

Channel 48 -Chain A

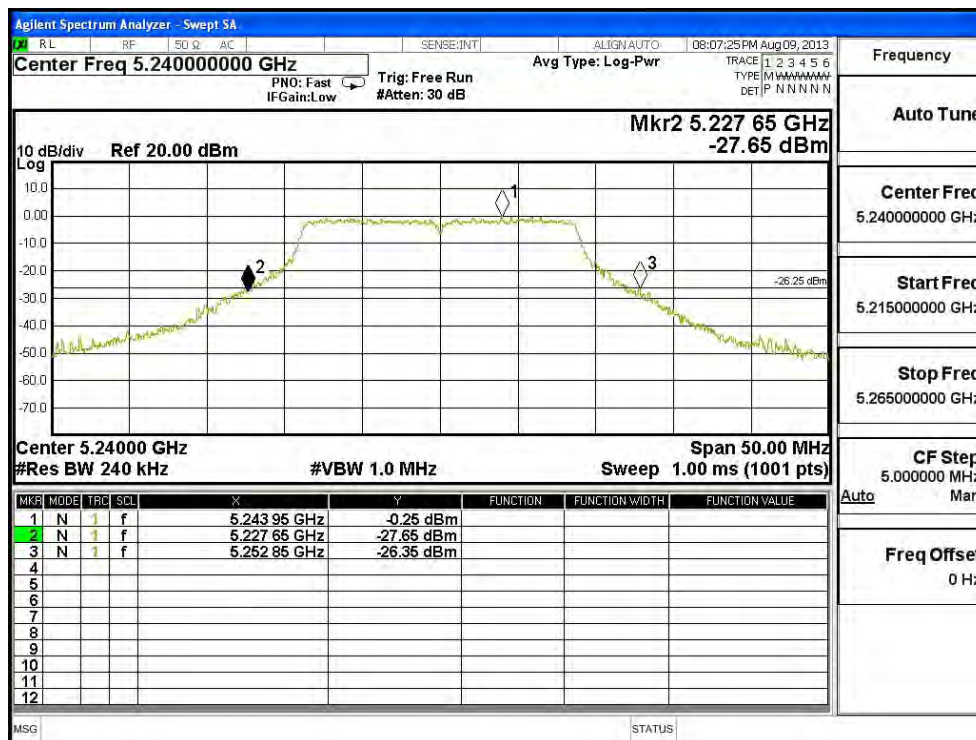

### 26dBc Occupied Bandwidth: Channel 36 -Chain B

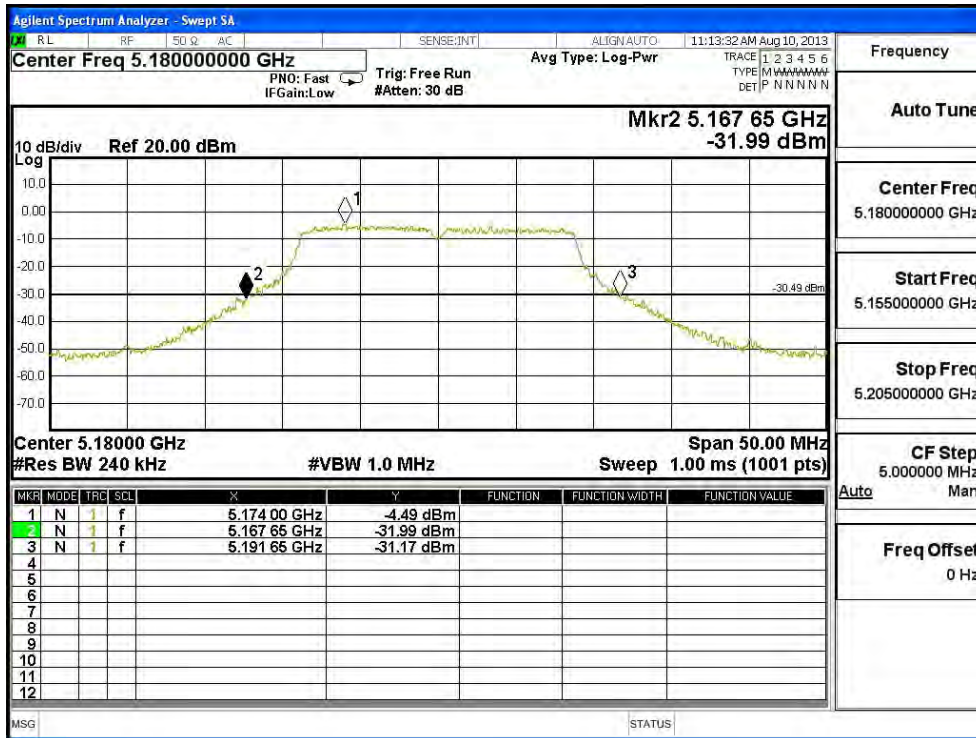

### Channel 44 -Chain B

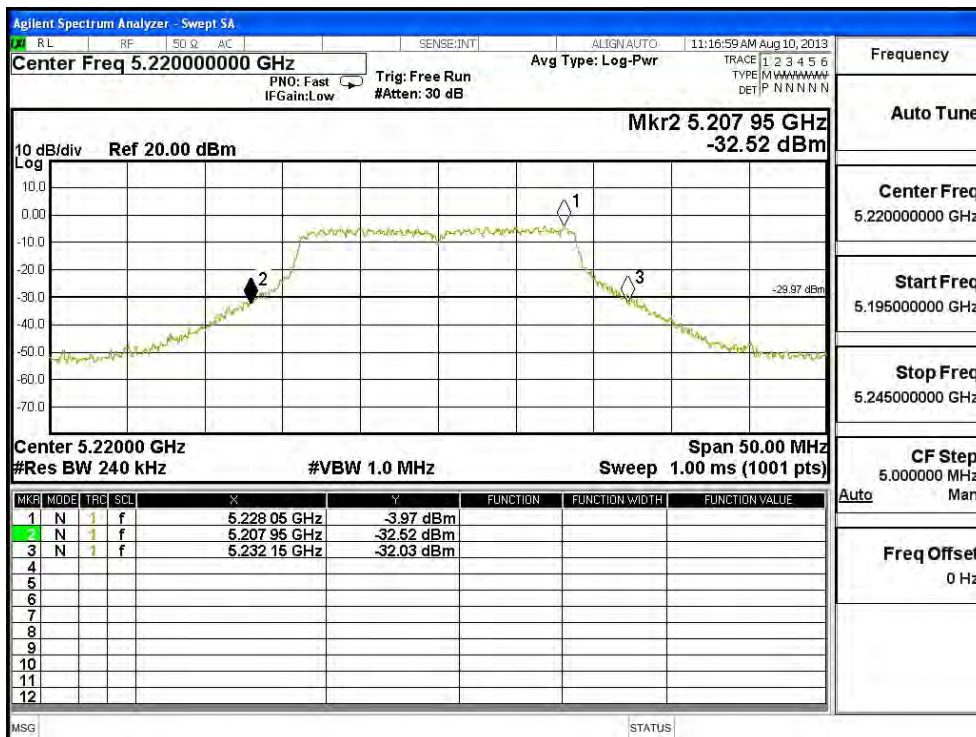

Channel 48 -Chain B

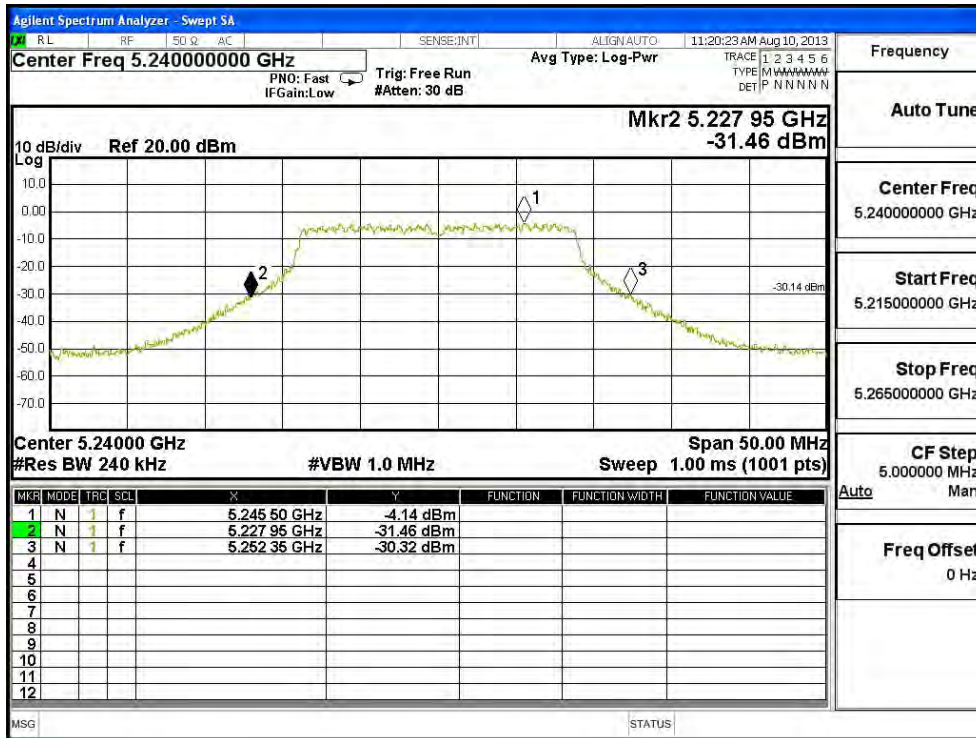

26dBc Occupied Bandwidth:  
Channel 36 -Chain C

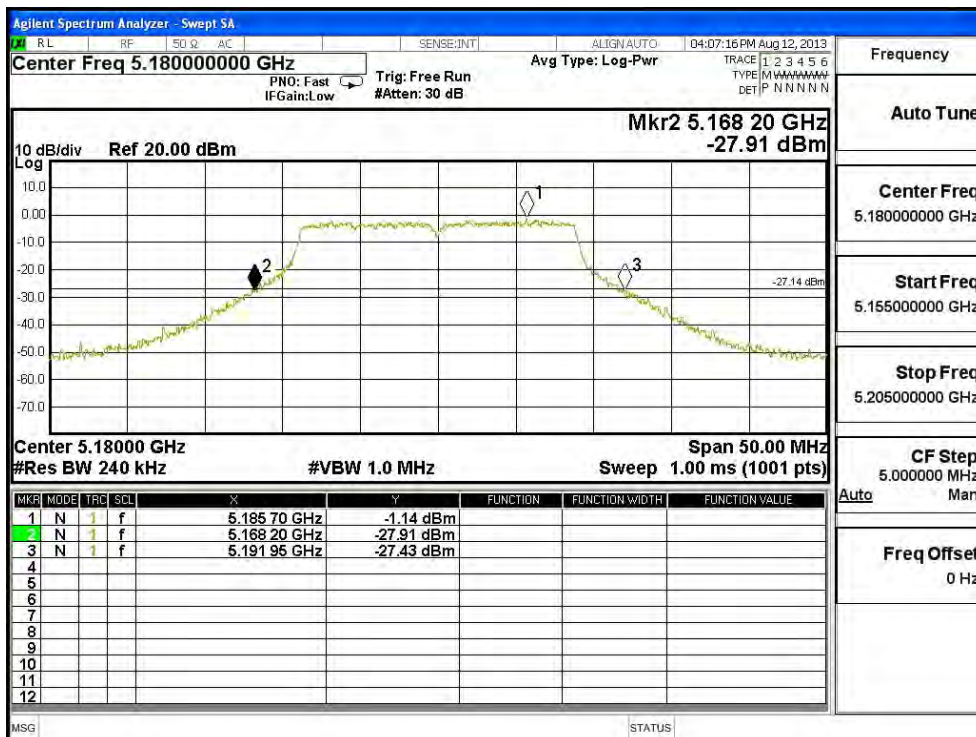

### Channel 44 -Chain C

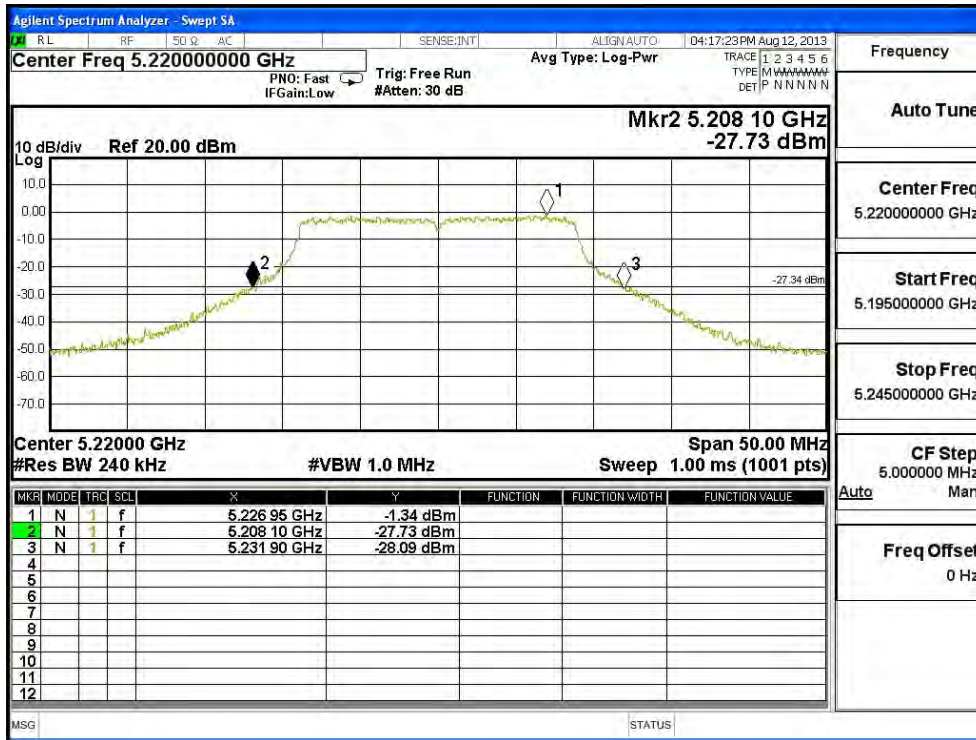

### Channel 48 -Chain C

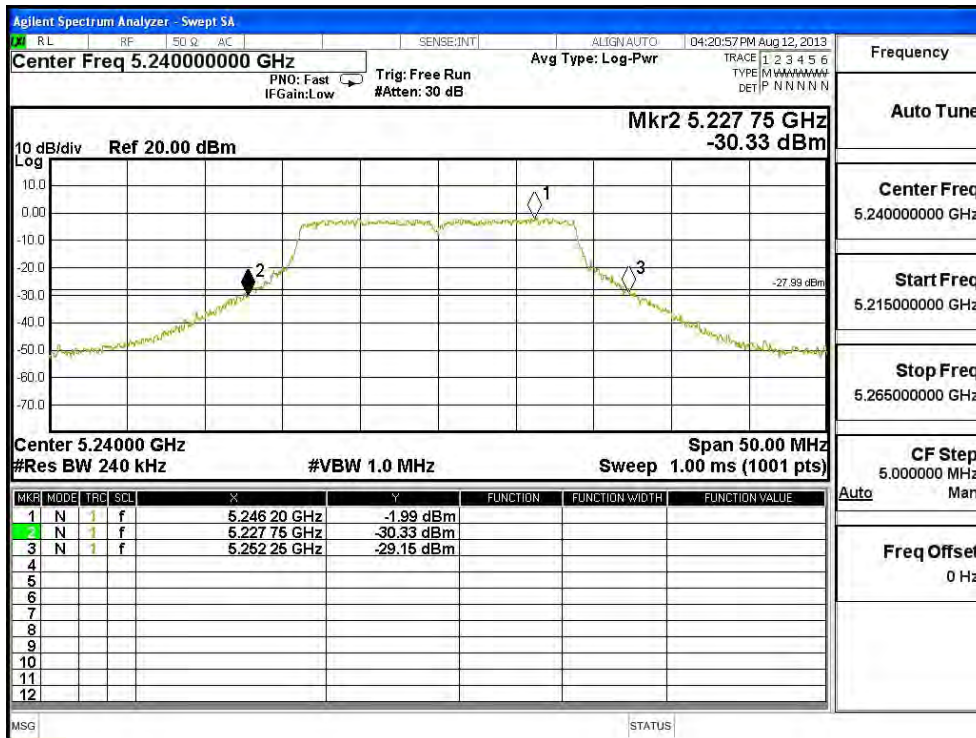

Product : SpectraGuard® Access Point / Sensor  
 Test Item : Maximum conducted output power  
 Test Site : No.3 OATS  
 Test Mode : Mode 6: Transmit (802.11n-40BW 45Mbps)(PIFA Antenna)

**CHAIN A**

Cable loss=1dB		Maximum conducted output power								
Channel No.	Frequency (MHz)	Data Rate (Mbps)								Required Limit
		45	90	135	180	270	360	405	450	
		Measurement Level (dBm)								
38	5190	11.32	--	--	--	--	--	--	--	<17dBm
46	5230	11.04	10.89	10.74	10.59	10.44	10.29	10.14	9.99	<17dBm

Note: Maximum conducted output power Value =Reading value on average power meter + cable loss

**CHAIN B**

Cable loss=1dB		Maximum conducted output power								
Channel No.	Frequency (MHz)	Data Rate (Mbps)								Required Limit
		45	90	135	180	270	360	405	450	
		Measurement Level (dBm)								
38	5190	11.35	--	--	--	--	--	--	--	<17dBm
46	5230	11.43	11.31	11.19	11.07	10.95	10.83	10.71	10.59	<17dBm

Note: Maximum conducted output power Value =Reading value on average power meter + cable loss

**CHAIN C**

Cable loss=1dB		Maximum conducted output power								
Channel No.	Frequency (MHz)	Data Rate (Mbps)								Required Limit
		45	90	135	180	270	360	405	450	
		Measurement Level (dBm)								
38	5190	11.33	--	--	--	--	--	--	--	<17dBm
46	5230	11.29	11.11	10.96	10.79	10.63	10.46	10.30	10.13	<17dBm

Note: Maximum conducted output power Value =Reading value on average power meter + cable loss

**Maximum conducted output power Measurement:**

**(CHAIN A+ B+C)**

Channel Number	Frequency (MHz)	26dB Bandwidth (MHz)	Chain A Power (dBm)	Chain B Power (dBm)	Chain C Power (dBm)	Output Power (dBm)	Output Power Limit	
							(dBm)	dBm+10log(BW)
38	5190	46.500	11.32	11.35	11.33	16.10	17	20.67
46	5230	46.600	11.04	11.43	11.29	16.03	17	20.68

Note:

1. Power Output Value =Reading value on average power meter + cable loss
2. Output Power (dBm) = 10LOG (Chain A Power (mW)+ Chain B Power (mW) + Chain C Power (mW))
3. 26 dB Bandwidth is the bandwidth of chain A or chain B or chain C whichever is less bandwidth, output power limitation is more stringent.

**26dBc Occupied Bandwidth:  
Channel 38 – Chain A**

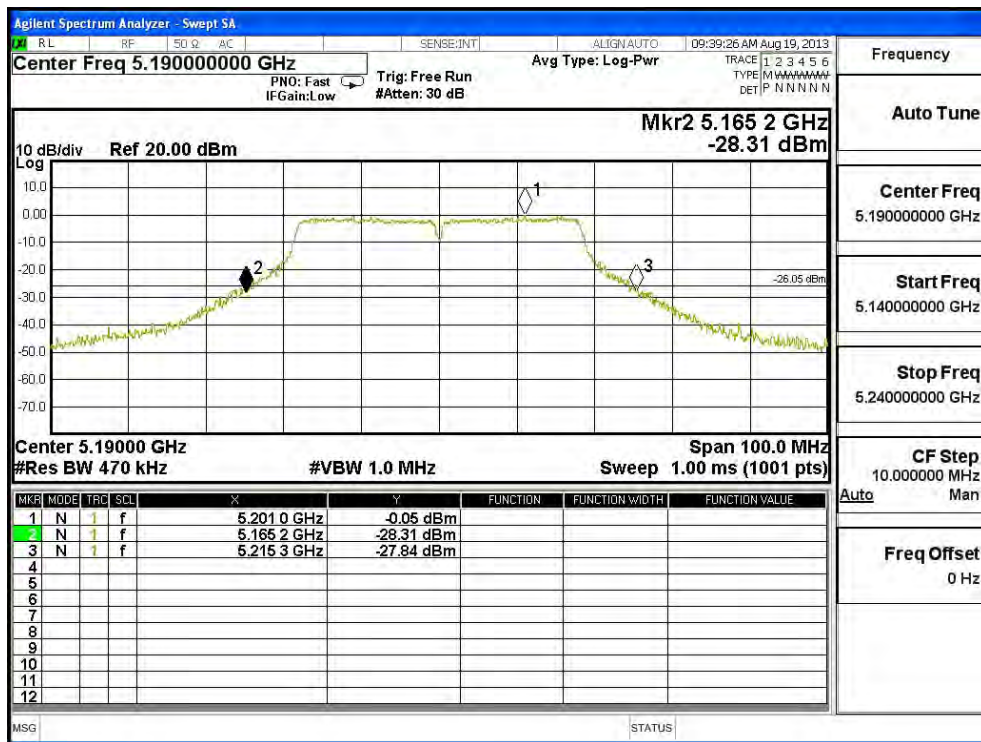

**Channel 46 – Chain A**

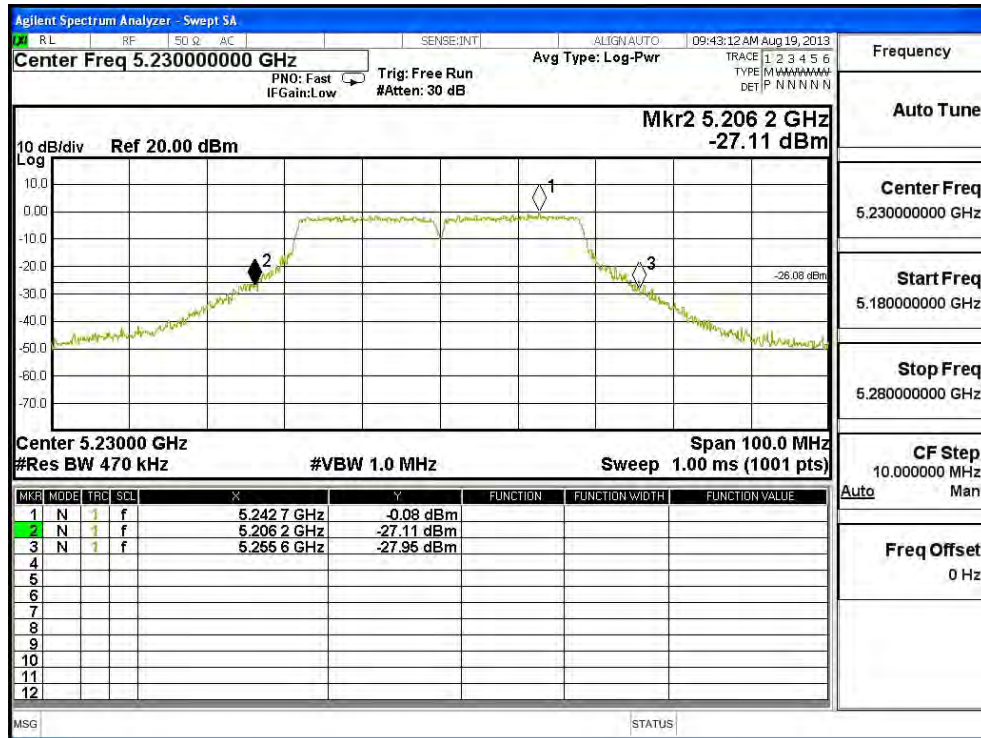

**26dBc Occupied Bandwidth:  
 Channel 38 – Chain B**

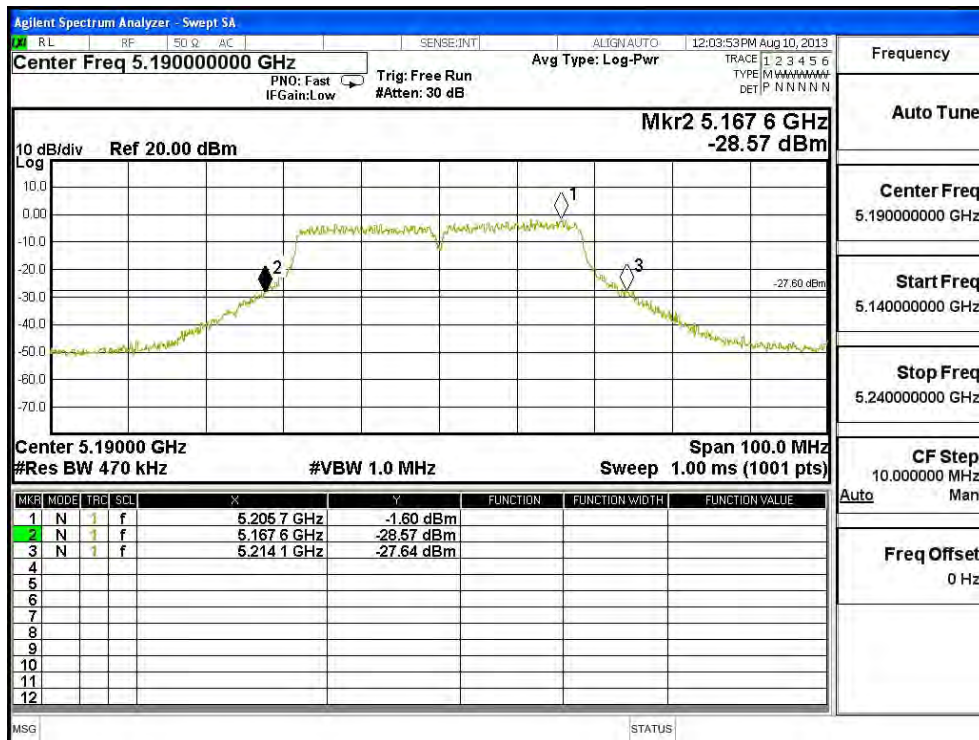



Channel 46 – Chain B

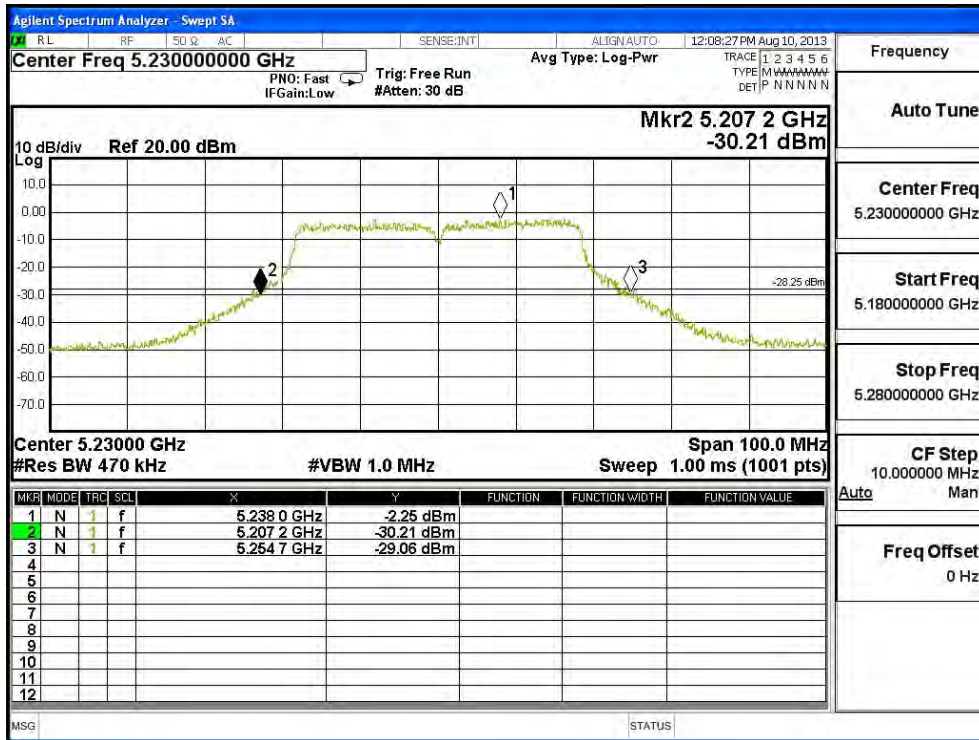

26dBc Occupied Bandwidth:  
Channel 38 – Chain C

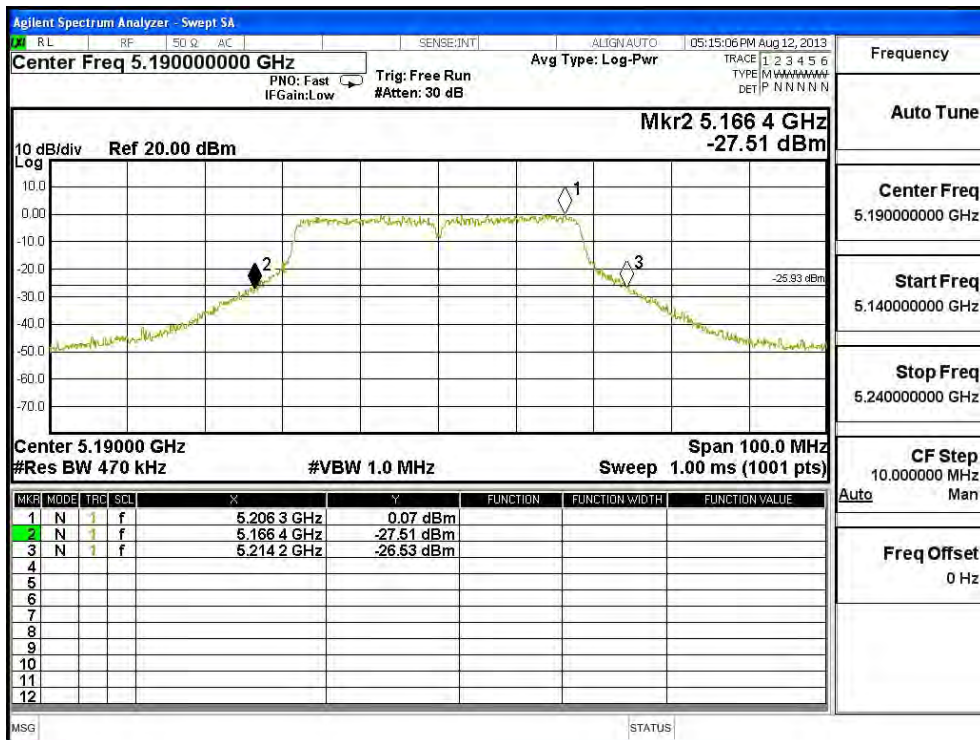

Channel 46 – Chain C

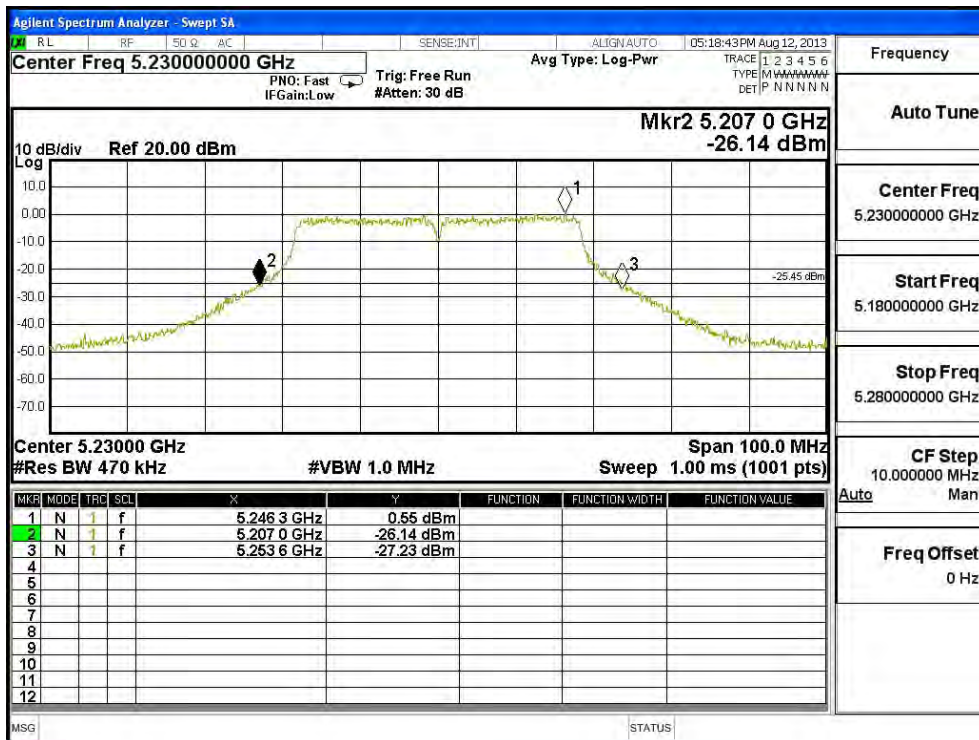

## 4. Peak Power Spectral Density

### 4.1. Test Equipment

	Equipment	Manufacturer	Model No./Serial No.	Last Cal.
	Spectrum Analyzer	R&S	FSP40 / 100170	Jun, 2013
	Spectrum Analyzer	Agilent	E4407B / US39440758	Jun, 2013
X	Spectrum Analyzer	Agilent	N9010A / MY48030495	Apr, 2013

Note:

1. All equipments are calibrated with traceable calibrations. Each calibration is traceable to the national or international standards.
2. The test instruments marked with “X” are used to measure the final test results.

### 4.2. Test Setup

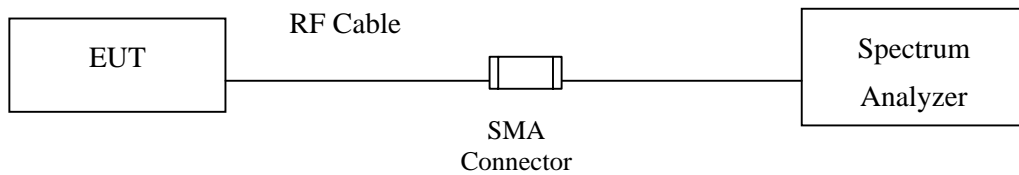

### 4.3. Limits

- (4) For the band 5.15-5.25 GHz, the peak power spectral density shall not exceed 4 dBm in any 1-MHz band. If transmitting antenna of directional gain greater than 6 dBi are used, the peak power spectral density shall be reduced by the amount in dB that directional gain of the antenna exceeds 6 dBi.
- (5) For the band 5.25-5.35 GHz, the peak power spectral density shall not exceed 11 dBm in any 1-MHz band. If transmitting antenna of directional gain greater than 6 dBi are used, the peak power spectral density shall be reduced by the amount in dB that directional gain of the antenna exceeds 6 dBi.
- (6) For the band 5.725-5.825 GHz, the peak power spectral density shall not exceed 17 dBm in any 1-MHz band. If transmitting antenna of directional gain greater than 6 dBi are used, the peak power spectral density shall be reduced by the amount in dB that directional gain of the antenna exceeds 6 dBi.

#### 4.4. Test Procedure

The EUT was setup to ANSI C63.10, 2009; tested to DTS test procedure of FCC KDB-789033 for compliance to FCC 47CFR Subpart E requirements.

The Peak Power Spectral Density using KDB 789033 section F) procedure, Create an average power spectrum for the EUT operating mode being tested by following the instructions in section E)2) for measuring maximum conducted output power using a spectrum analyzer.

SA-1 method is selected to run the test.

#### 4.5. Uncertainty

$\pm 1.27$  dB

#### 4.6. Test Result of Peak Power Spectral Density

Product : SpectraGuard® Access Point / Sensor  
 Test Item : Peak Power Spectral Density  
 Test Site : No.3 OATS  
 Test Mode : Mode 1: Transmit (802.11 a-6Mbps)(Dipole Antenna)

Channel No.	Frequency (MHz)	Chain (dBm)	PPSD/MHz (dBm)	Total PPSD/MHz (dBm)	Required Limit (dBm)	Result
36	5180	A	-3.100	1.671	<4	Pass
		B	-6.600	-1.829	<4	Pass
		C	-4.640	0.131	<4	Pass
44	5220	A	-4.870	-0.099	<4	Pass
		B	-7.320	-2.549	<4	Pass
		C	-5.430	-0.659	<4	Pass
48	5240	A	-5.770	-0.999	<4	Pass
		B	-8.400	-3.629	<4	Pass
		C	-6.490	-1.719	<4	Pass

Note 1: The quantity  $10 \cdot \log 3$  (two antennas) is added to the spectrum peak value according to document 662911 D01.

**Channel 36: CHAIN A**

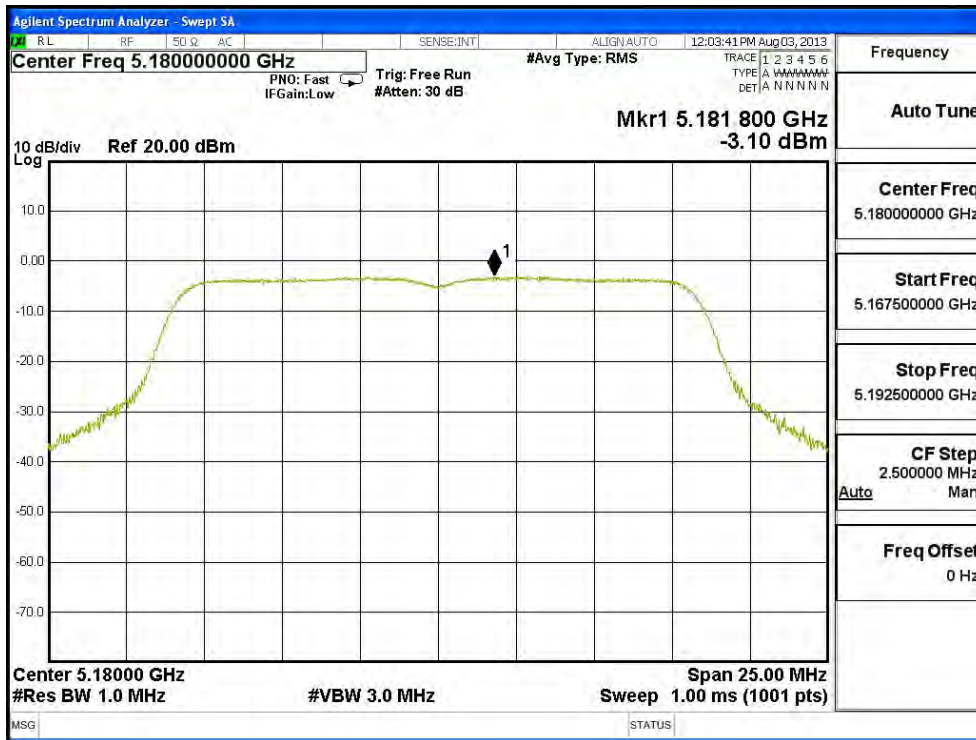

**Channel 44: CHAIN A**



**Channel 48: CHAIN A**



**Channel 36: CHAIN B**

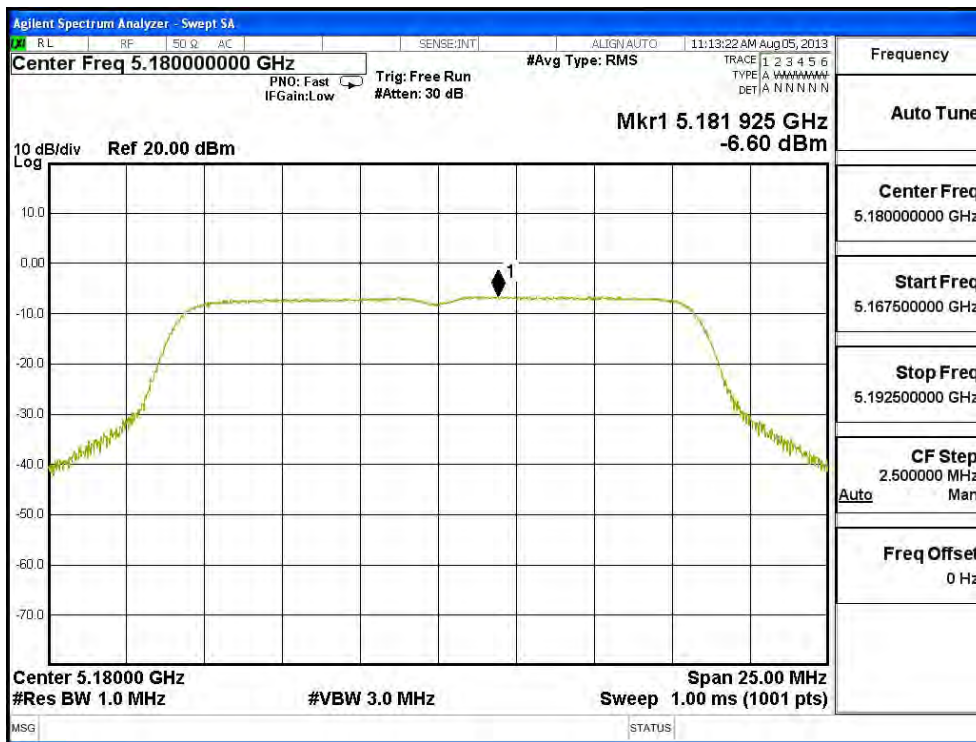

**Channel 44: CHAIN B**





**Channel 48: CHAIN B**



### Channel 36: CHAIN C

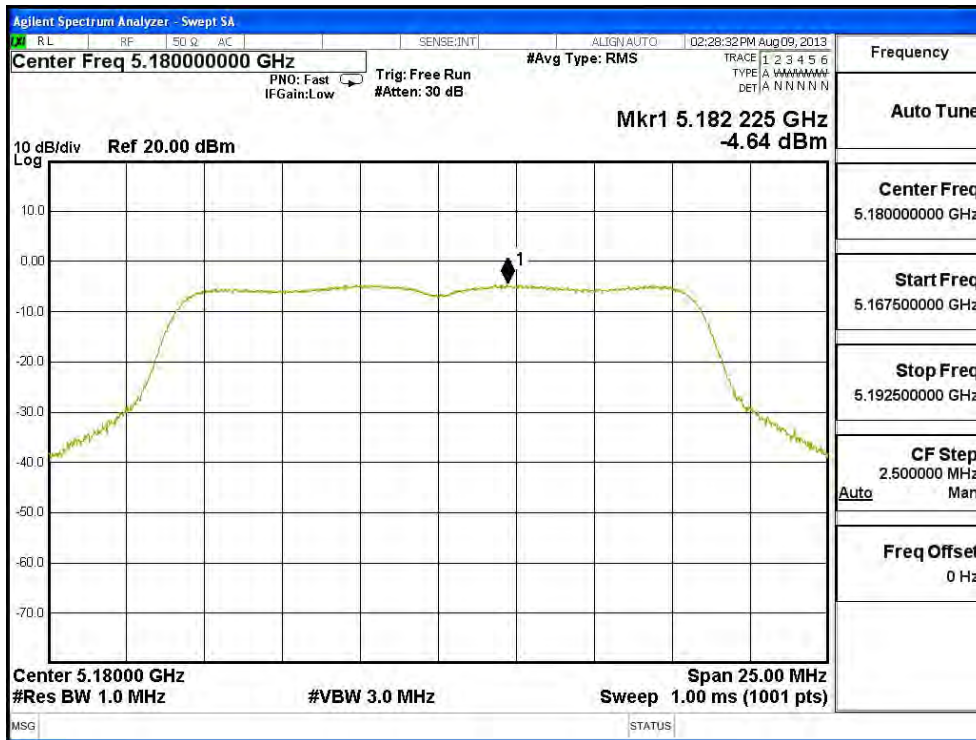

### Channel 44: CHAIN C

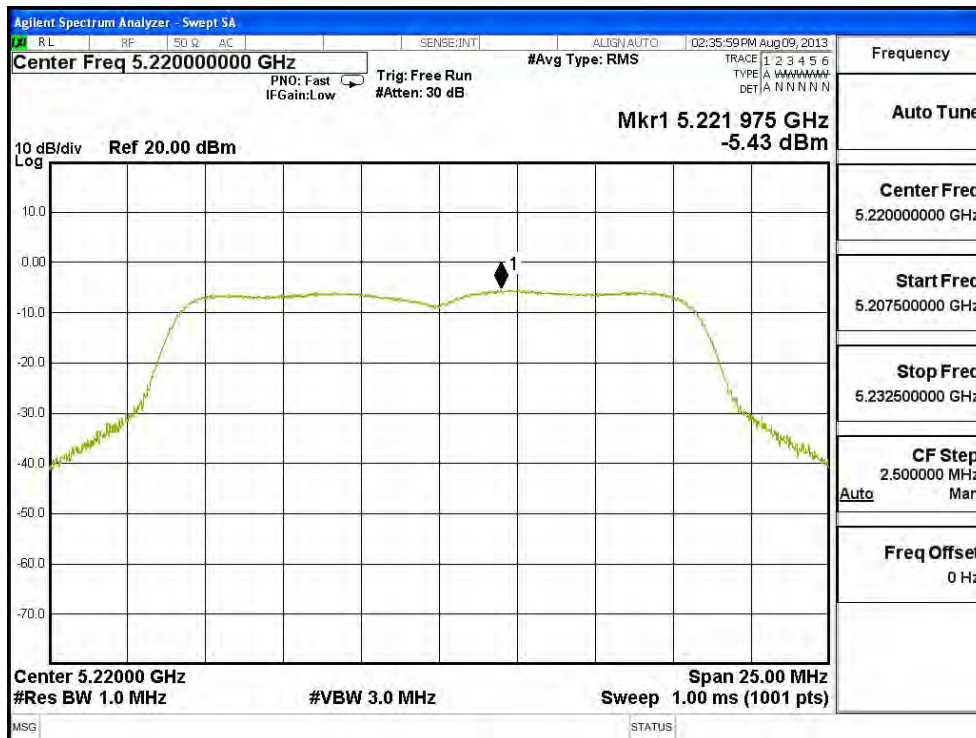

**Channel 48: CHAIN C**

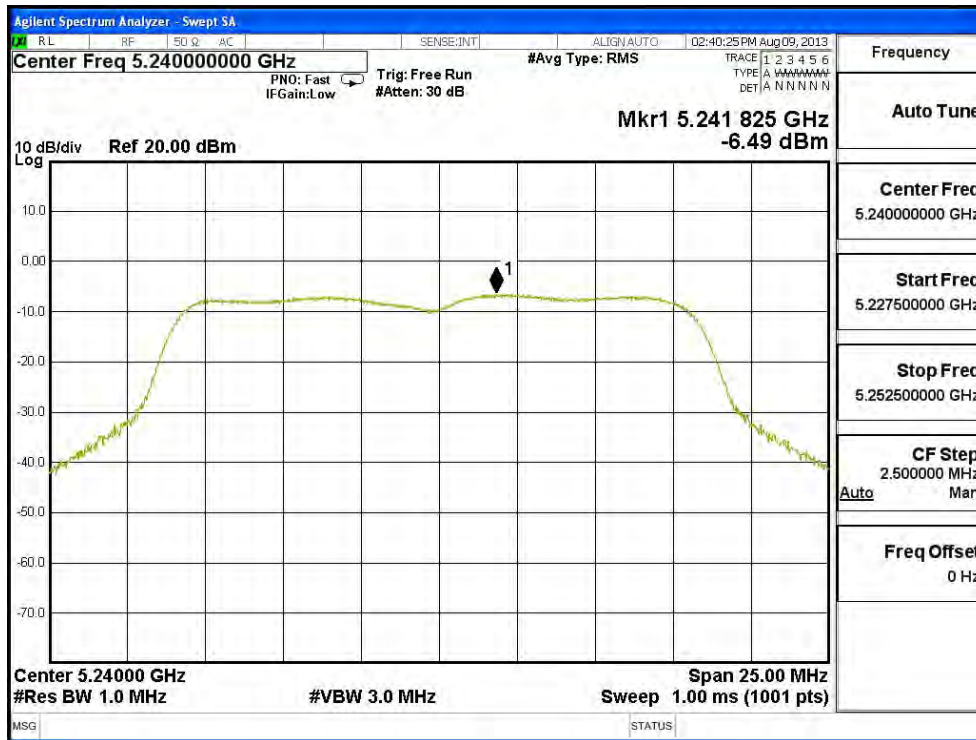

Product : SpectraGuard® Access Point / Sensor  
 Test Item : Peak Power Spectral Density  
 Test Site : No.3 OATS  
 Test Mode : Mode 2: Transmit (802.11n-20BW 21.7Mbps)(Dipole Antenna)

Channel No.	Frequency (MHz)	Chain (dBm)	PPSD/MHz (dBm)	Total PPSD/MHz (dBm)	Required Limit (dBm)	Result
36	5180	A	-5.210	-0.439	<4	Pass
		B	-7.320	-2.549	<4	Pass
		C	-5.300	-0.529	<4	Pass
44	5220	A	-5.580	-0.809	<4	Pass
		B	-7.990	-3.219	<4	Pass
		C	-5.100	-0.329	<4	Pass
48	5240	A	-5.540	-0.769	<4	Pass
		B	-8.220	-3.449	<4	Pass
		C	-5.630	-0.859	<4	Pass

Note 1: The quantity  $10 \cdot \log 3$  (two antennas) is added to the spectrum peak value according to document 662911 D01.

**Channel 36 – Chain A**

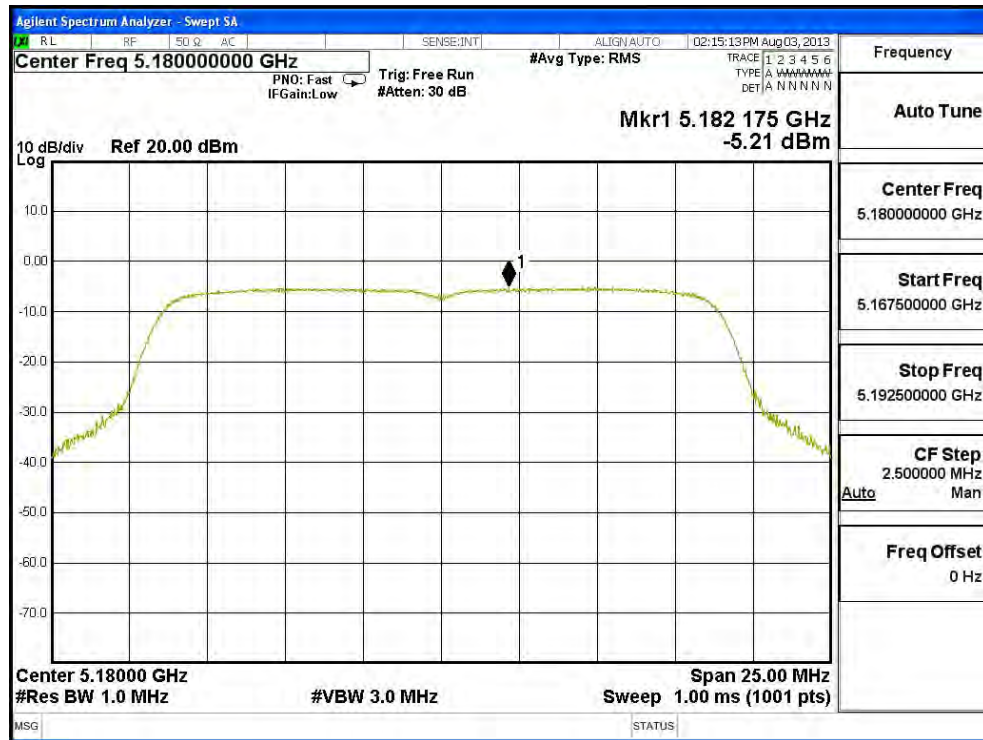

**Channel 44 – Chain A**

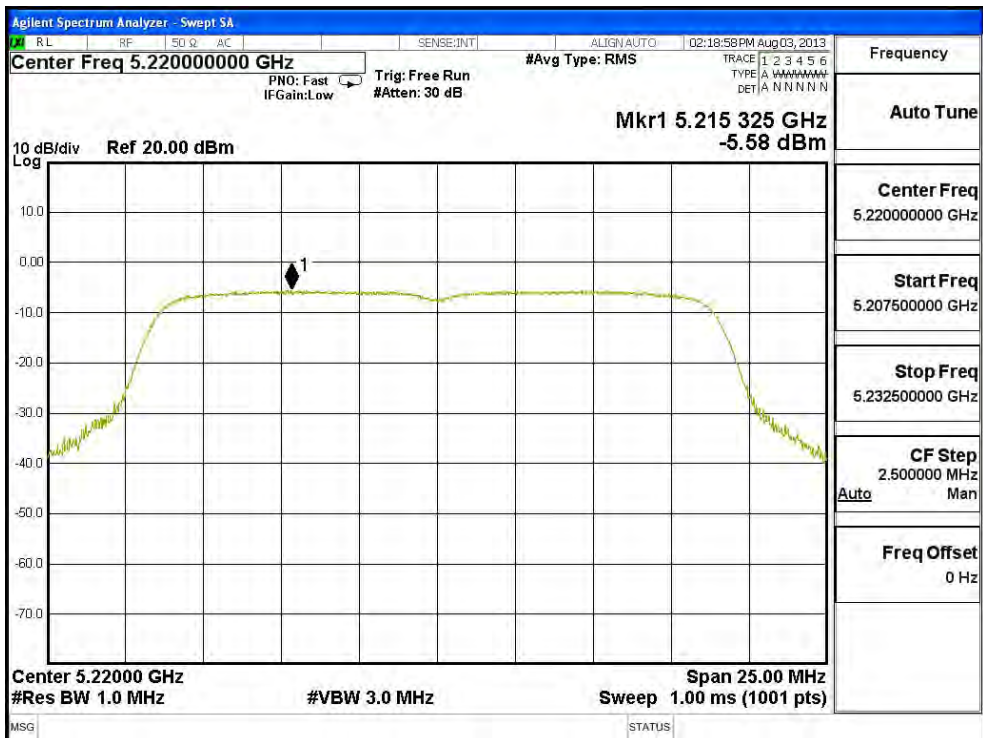

**Channel 48 – Chain A**

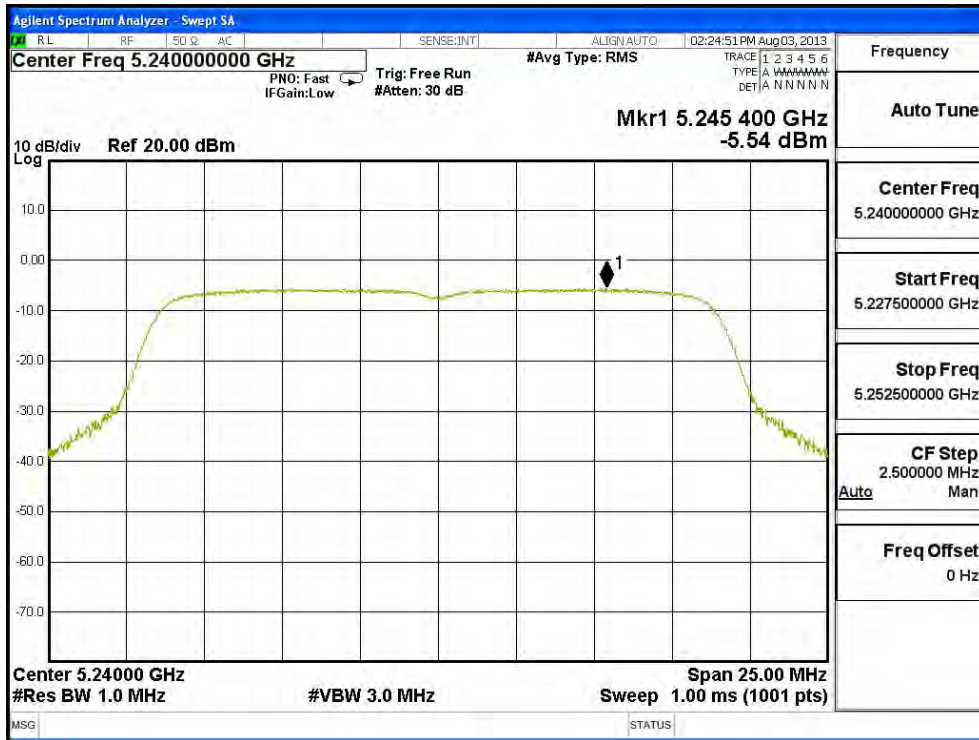

**Channel 36 – Chain B**

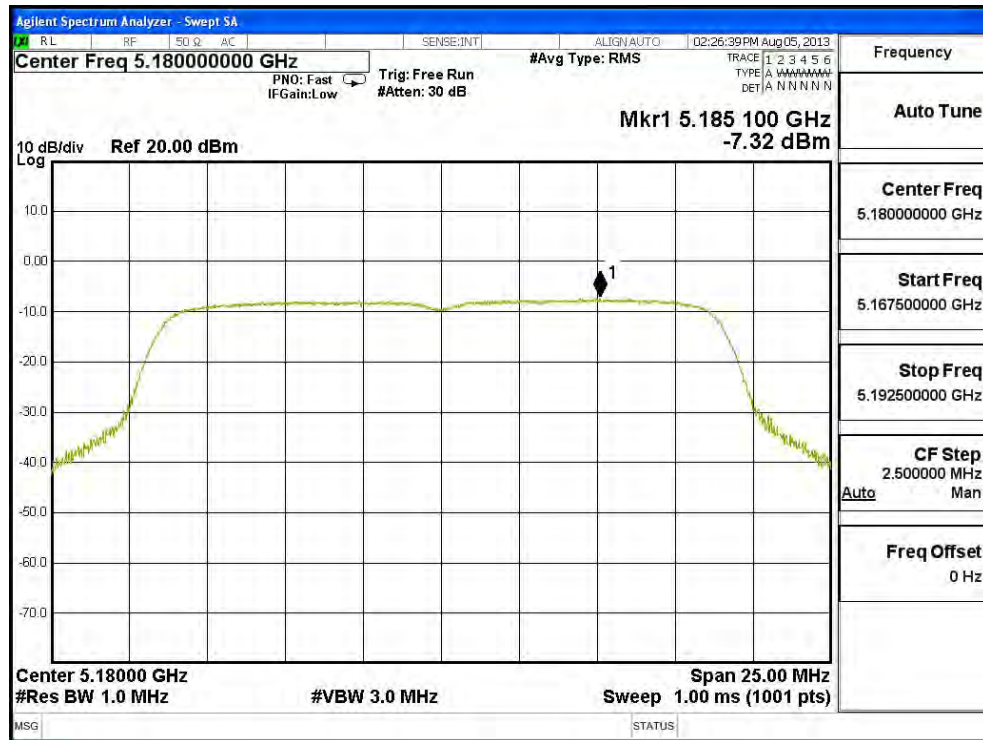

**Channel 44 – Chain B**



**Channel 48 – Chain B**

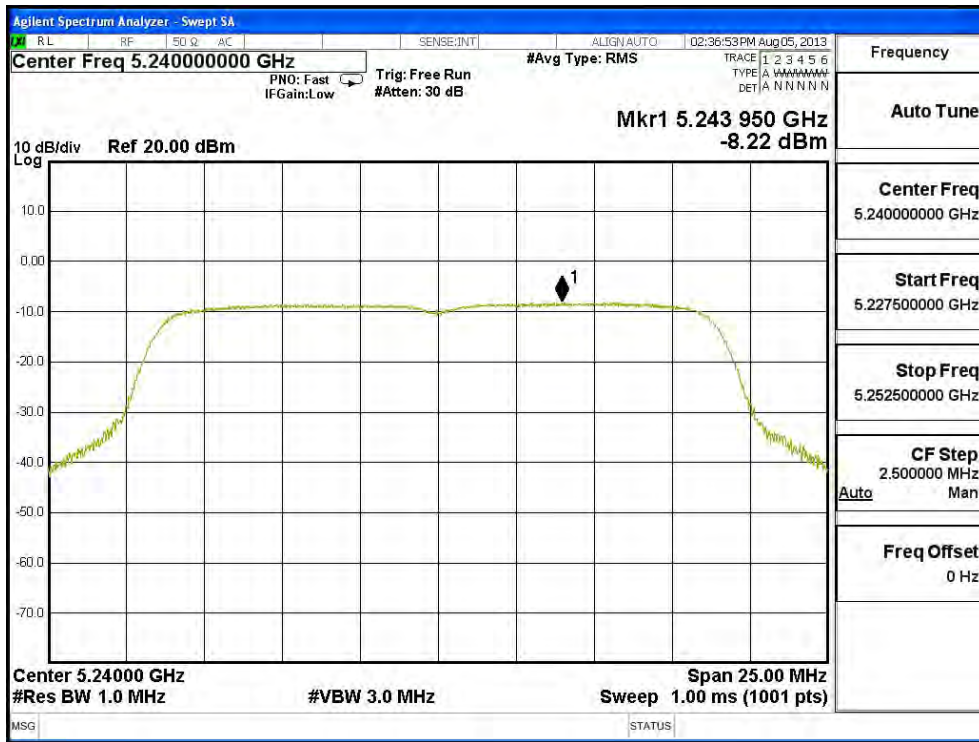



### Channel 36 – Chain C

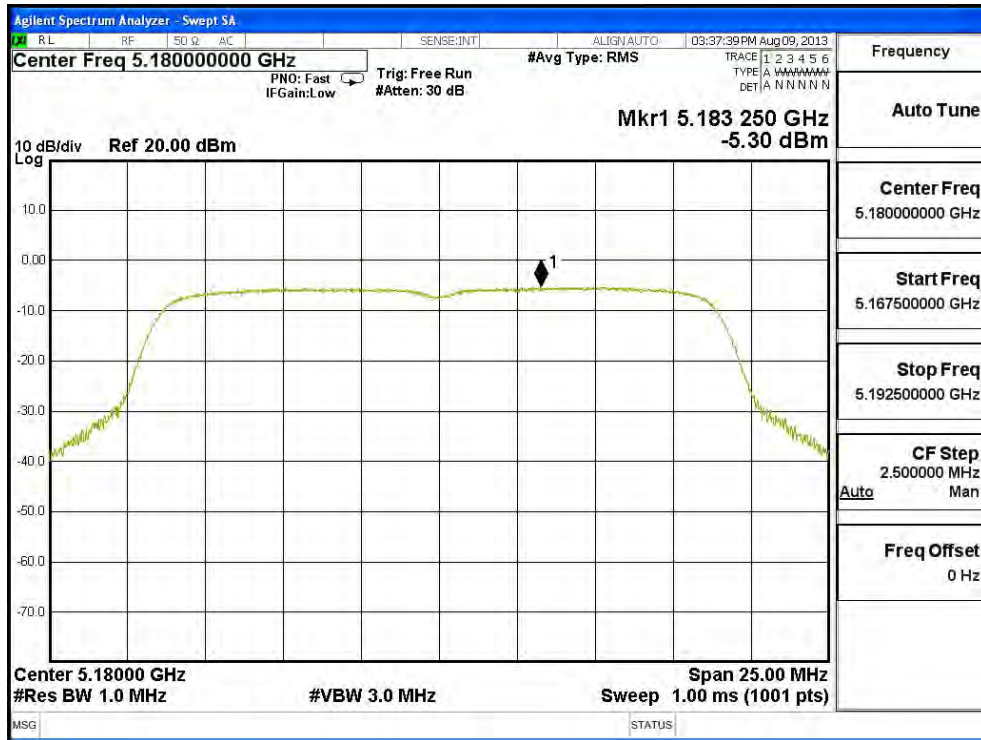

### Channel 44 – Chain C



**Channel 48 – Chain C**

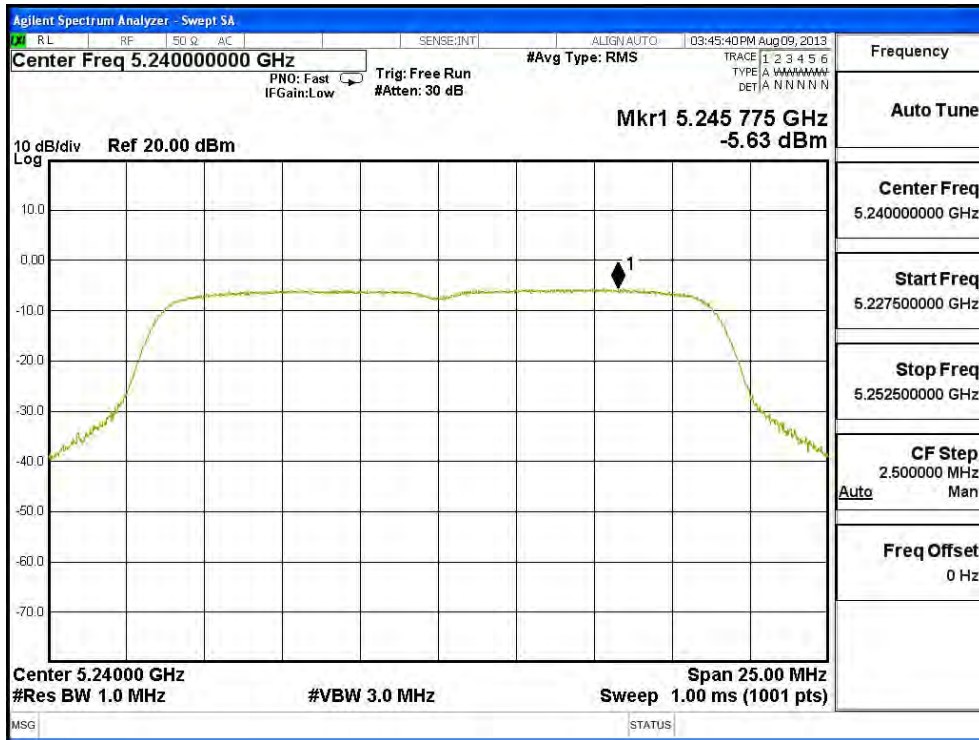

Product : SpectraGuard® Access Point / Sensor  
 Test Item : Peak Power Spectral Density  
 Test Site : No.3 OATS  
 Test Mode : Mode 3: Transmit (802.11n-40BW 45Mbps)(Dipole Antenna)

Channel No.	Frequency (MHz)	Chain (dBm)	PPSD/MHz (dBm)	Total PPSD/MHz (dBm)	Required Limit (dBm)	Result
38	5190	A	-8.380	-3.609	<4	Pass
		B	-9.760	-4.989	<4	Pass
		C	-7.740	-2.969	<4	Pass
46	5230	A	-8.540	-3.769	<4	Pass
		B	-10.460	-5.689	<4	Pass
		C	-7.690	-2.919	<4	Pass

Note 1: The quantity  $10 \cdot \log 3$  (two antennas) is added to the spectrum peak value according to document 662911 D01.

### Channel 38 – Chain A

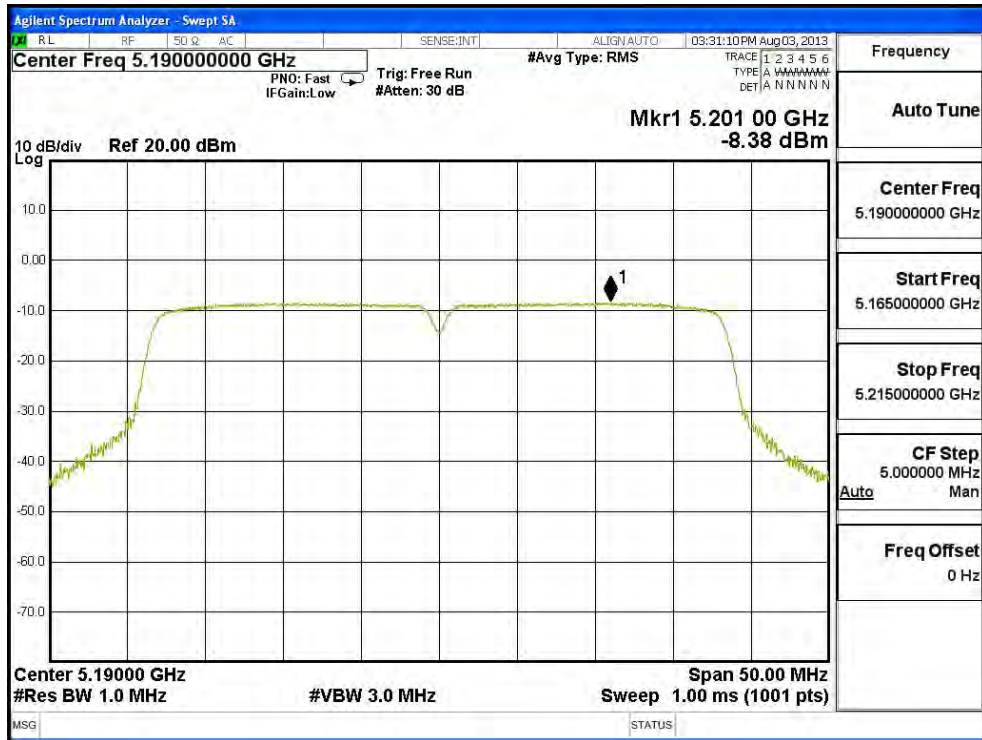

### Channel 46 – Chain A

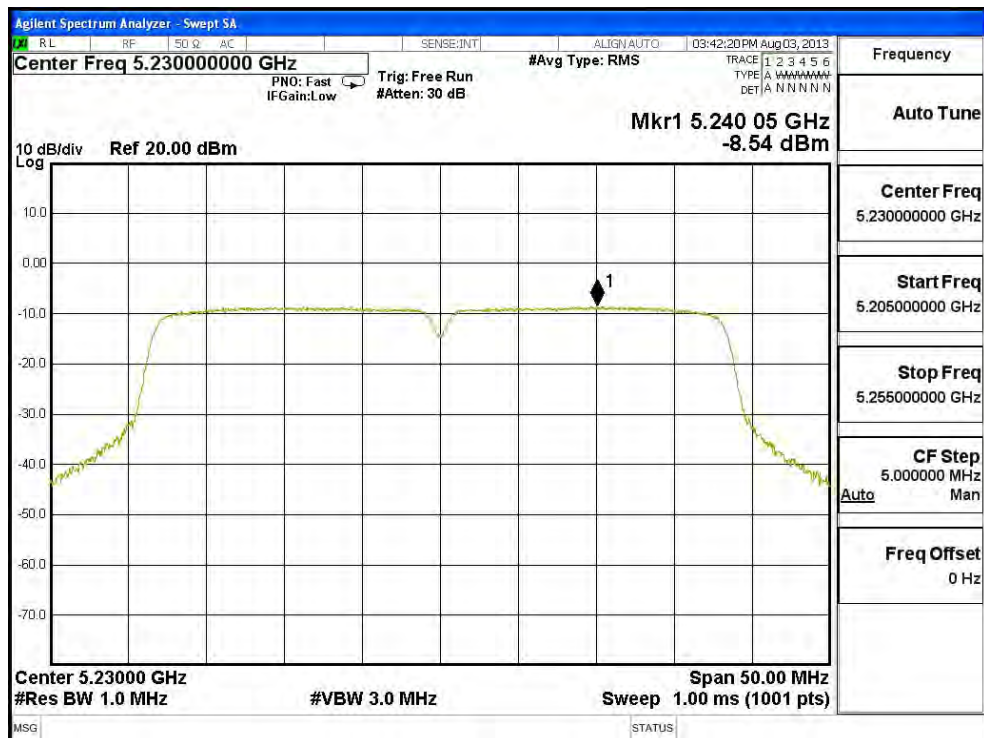

**Channel 38 – Chain B**



**Channel 46 – Chain B**

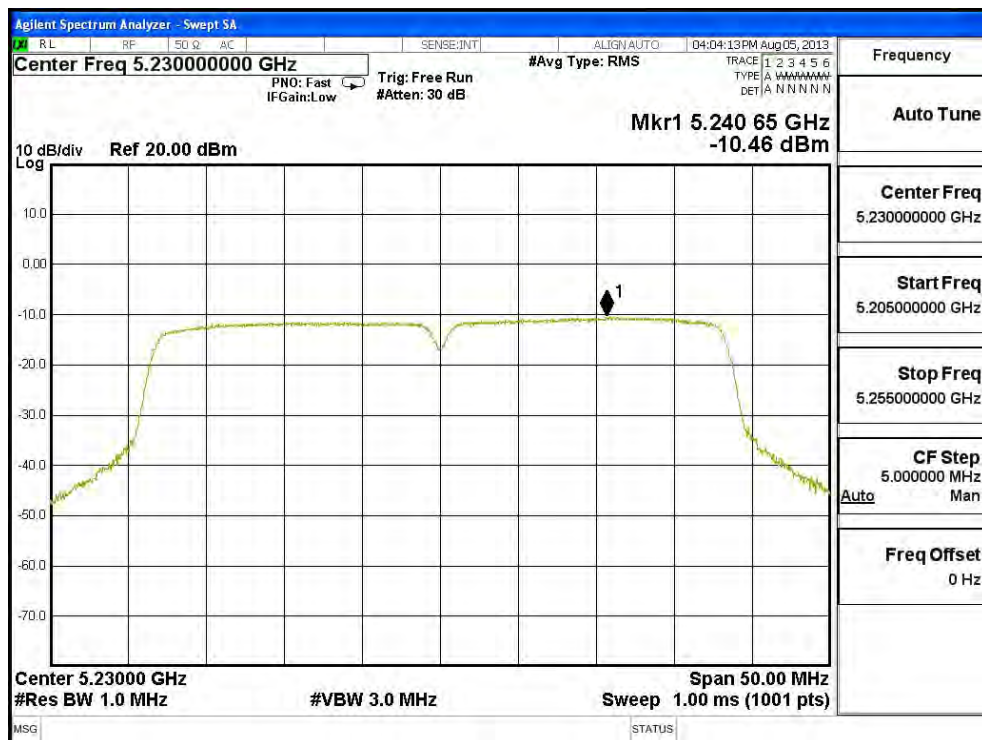

### Channel 38 – Chain C

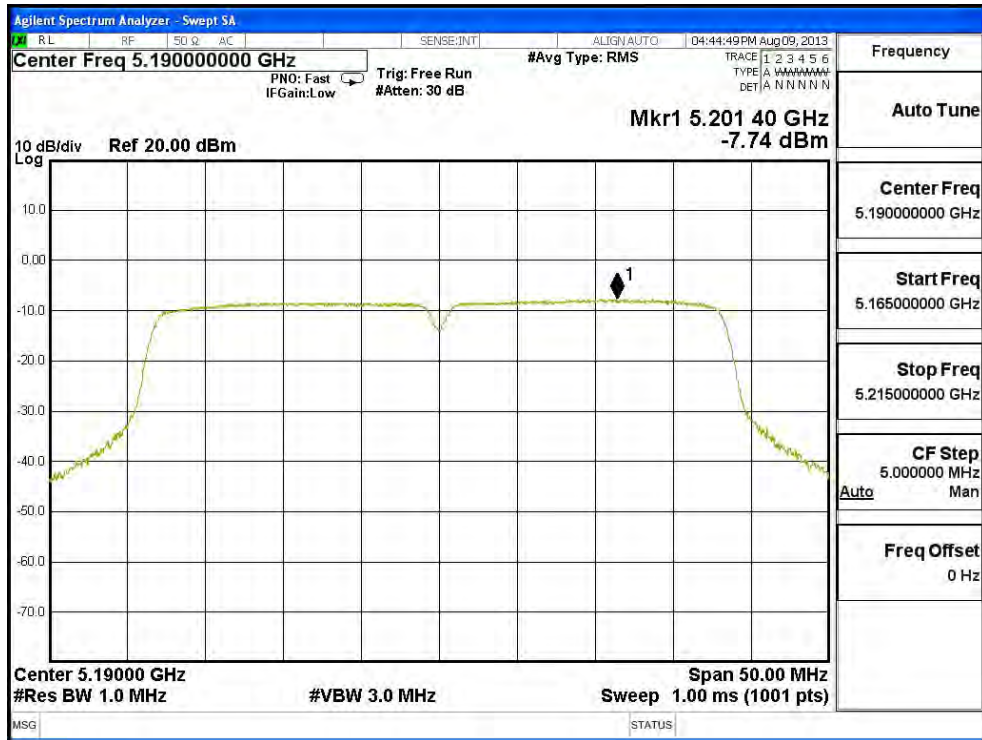

### Channel 46 – Chain C

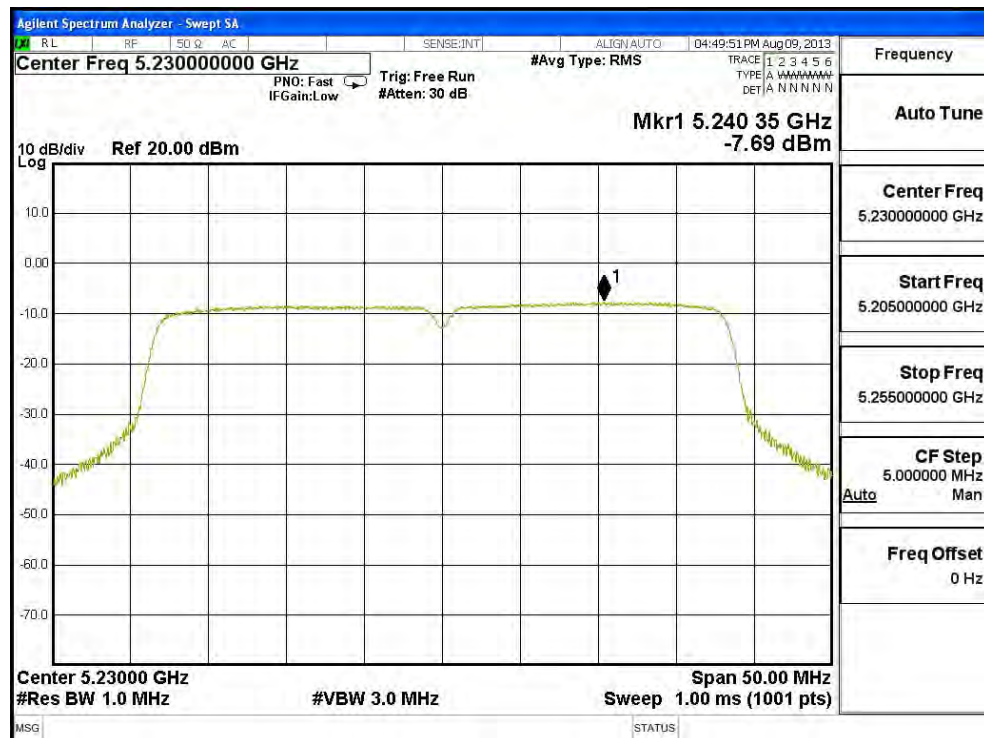

Product : SpectraGuard® Access Point / Sensor  
 Test Item : Peak Power Spectral Density  
 Test Site : No.3 OATS  
 Test Mode : Mode 4: Transmit (802.11a-6Mbps)(PIFA Antenna)

Channel No.	Frequency (MHz)	Chain (dBm)	PPSD/MHz (dBm)	Total PPSD/MHz (dBm)	Required Limit (dBm)	Result
36	5180	A	-1.010	3.761	<4	Pass
		B	-4.790	-0.019	<4	Pass
		C	-1.430	3.341	<4	Pass
44	5220	A	-1.370	3.401	<4	Pass
		B	-4.880	-0.109	<4	Pass
		C	-2.560	2.211	<4	Pass
48	5240	A	-1.850	2.921	<4	Pass
		B	-5.810	-1.039	<4	Pass
		C	-2.690	2.081	<4	Pass

Note 1: The quantity  $10 \cdot \log 3$  (two antennas) is added to the spectrum peak value according to document 662911 D01.

**Channel 36: CHAIN A**

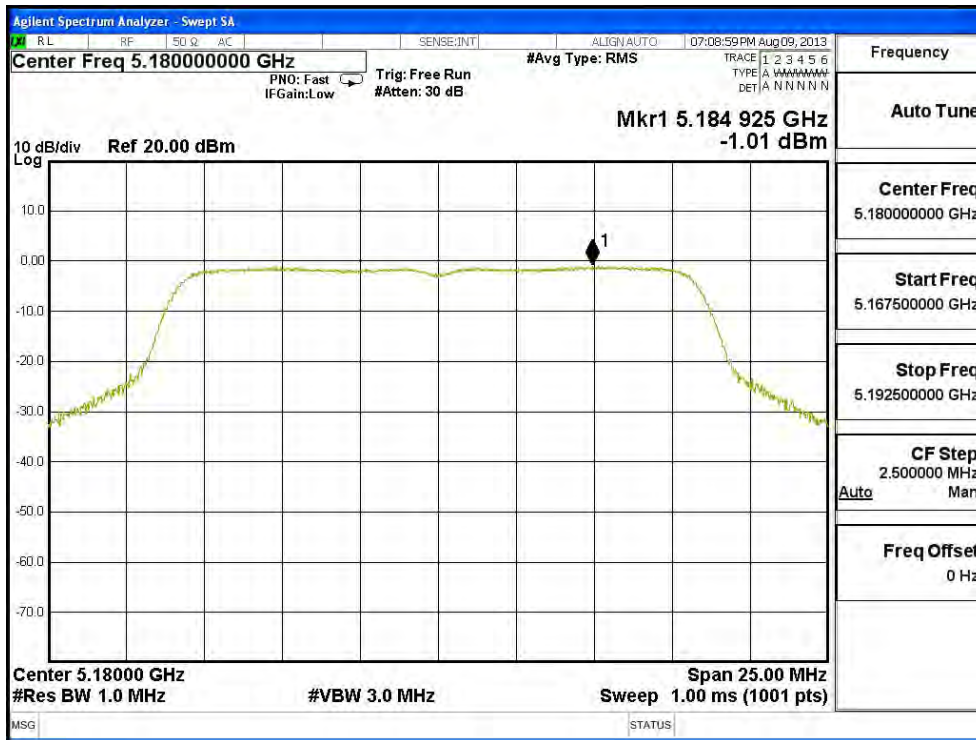

**Channel 44: CHAIN A**

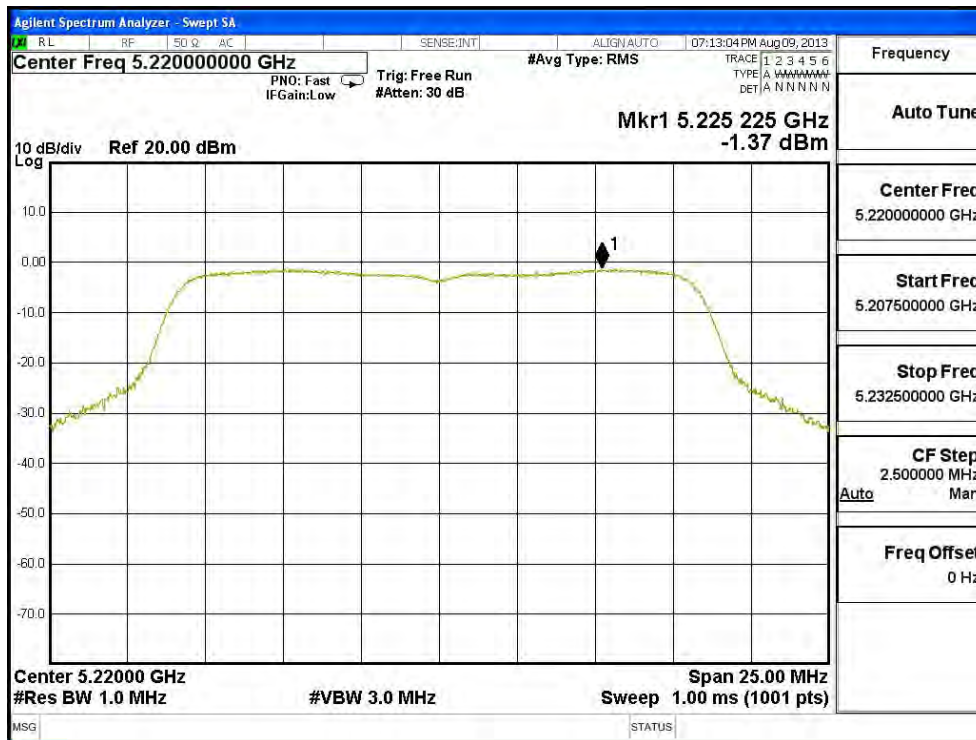



**Channel 48: CHAIN A**

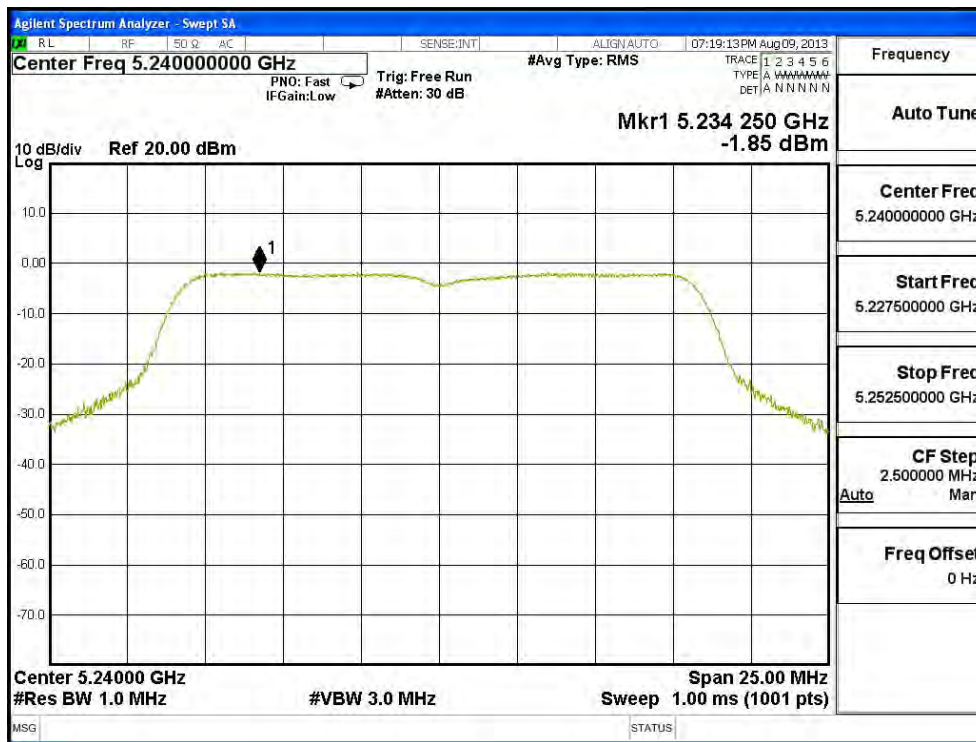

**Channel 36: CHAIN B**



**Channel 44: CHAIN B**

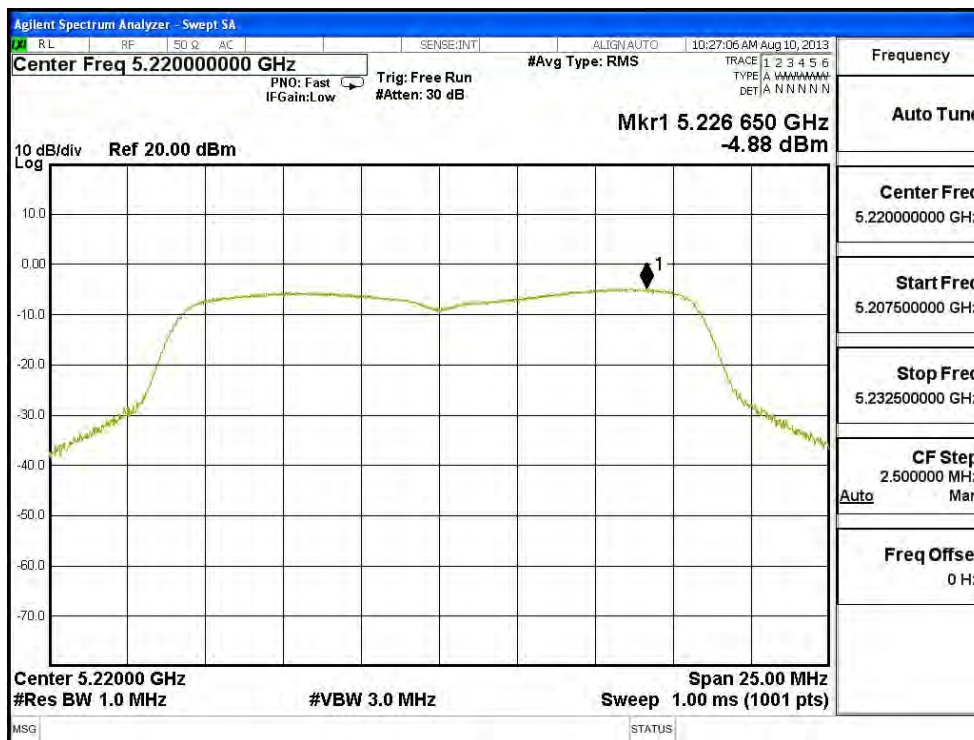

**Channel 48: CHAIN B**



**Channel 36: CHAIN C**

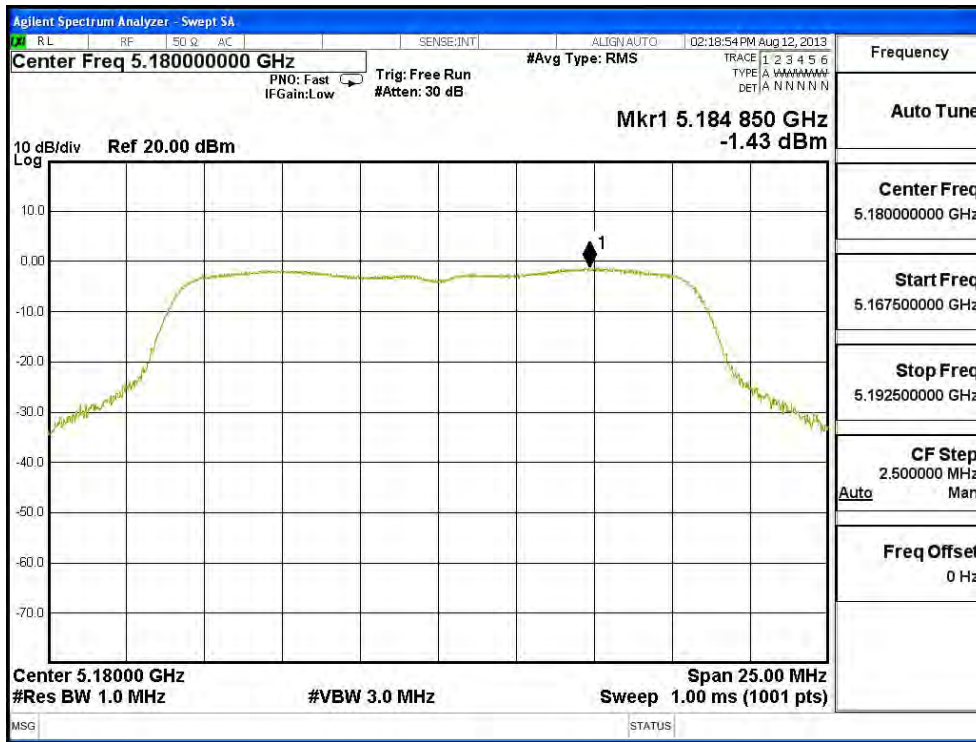

**Channel 44: CHAIN C**

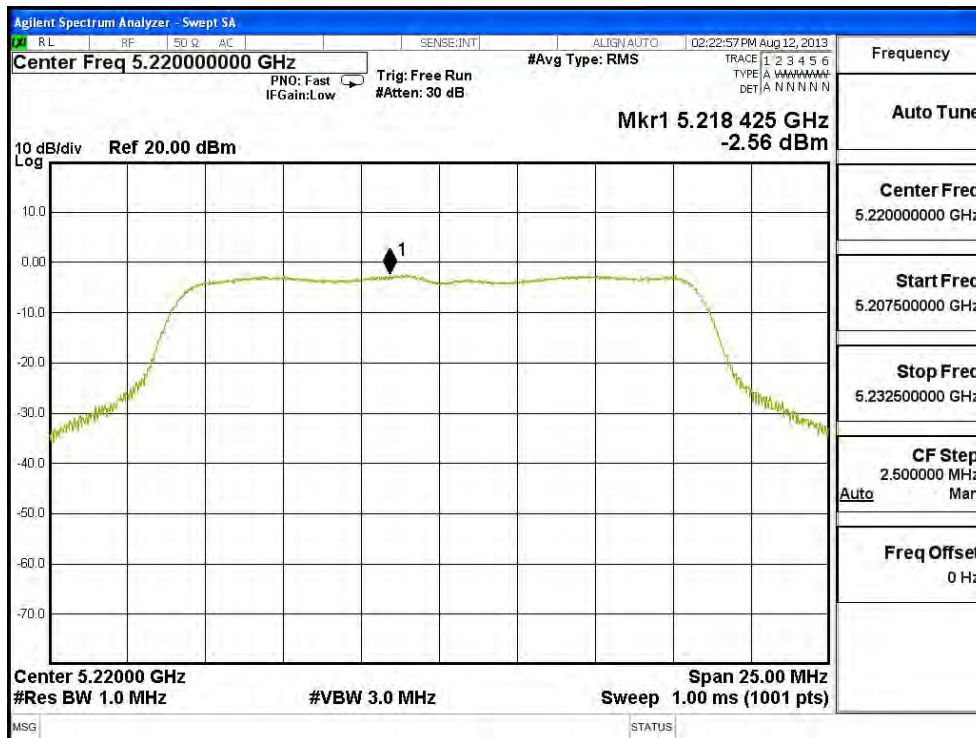

**Channel 48: CHAIN C**

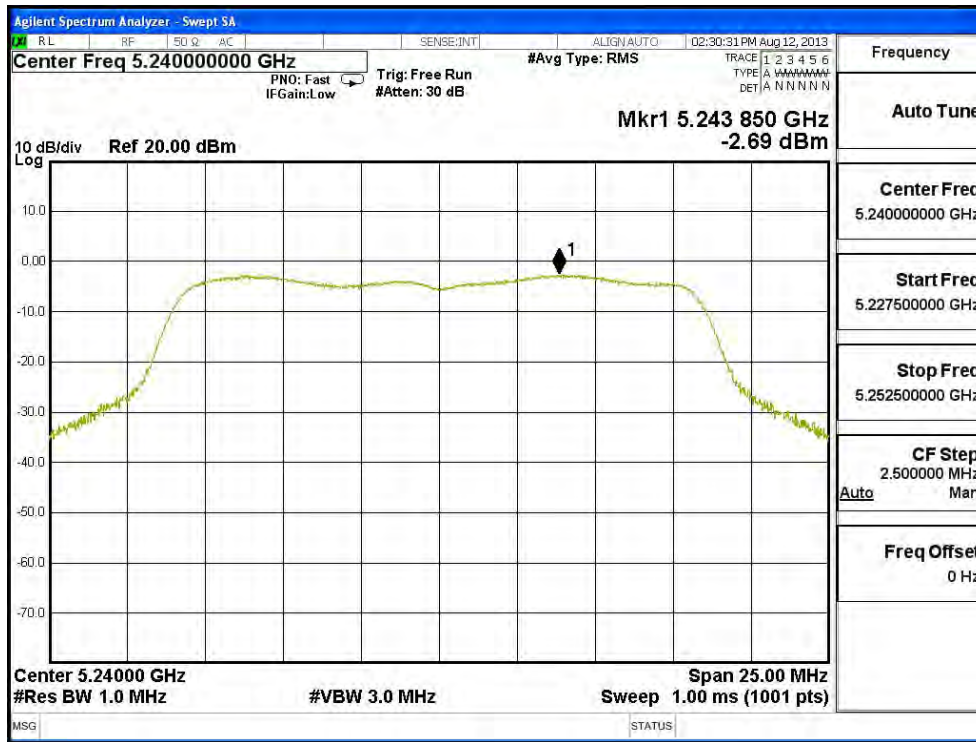

Product : SpectraGuard® Access Point / Sensor  
 Test Item : Peak Power Spectral Density  
 Test Site : No.3 OATS  
 Test Mode : Mode 5: Transmit (802.11n-20BW 21.7Mbps)(PIFA Antenna)

Channel No.	Frequency (MHz)	Chain (dBm)	PPSD/MHz (dBm)	Total PPSD/MHz (dBm)	Required Limit (dBm)	Result
36	5180	A	-2.650	2.121	<4	Pass
		B	-6.130	-1.359	<4	Pass
		C	-3.200	1.571	<4	Pass
44	5220	A	-2.160	2.611	<4	Pass
		B	-5.900	-1.129	<4	Pass
		C	-2.870	1.901	<4	Pass
48	5240	A	-2.100	2.671	<4	Pass
		B	-5.740	-0.969	<4	Pass
		C	-3.350	1.421	<4	Pass

Note 1: The quantity  $10 \cdot \log 3$  (two antennas) is added to the spectrum peak value according to document 662911 D01.

**Channel 36 – Chain A**

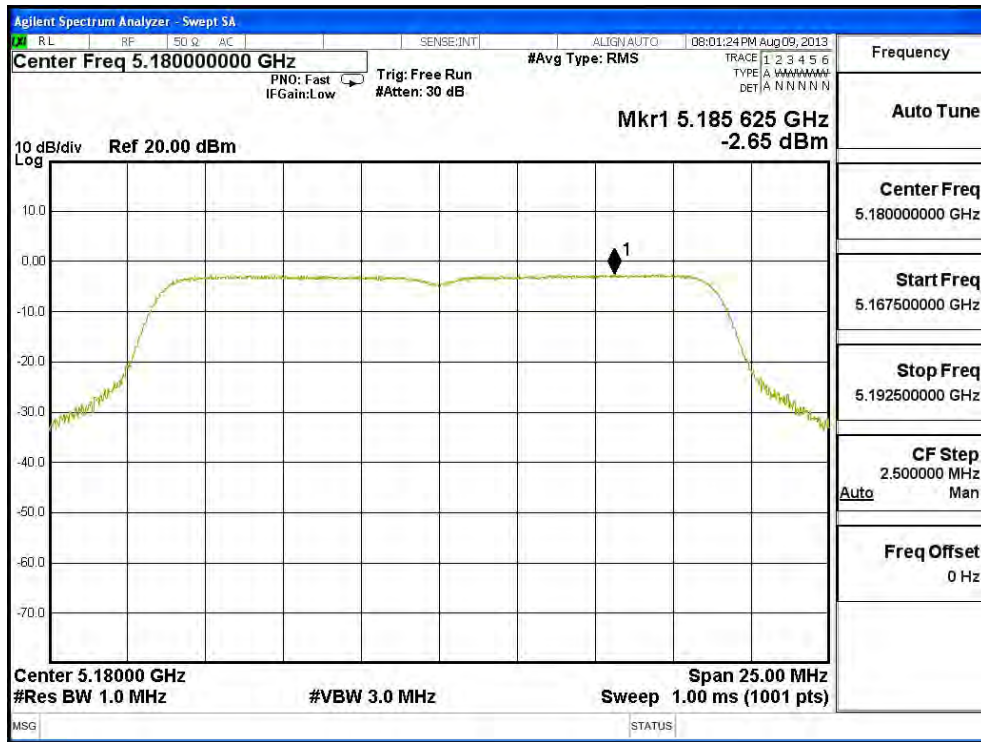

**Channel 44 – Chain A**

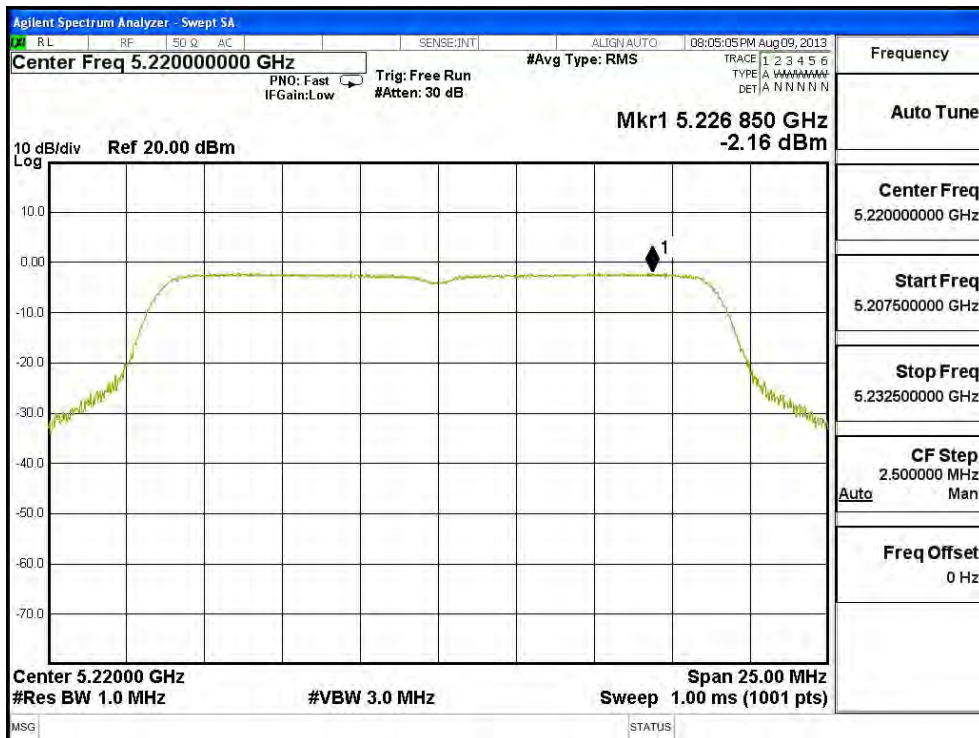

**Channel 48 – Chain A**

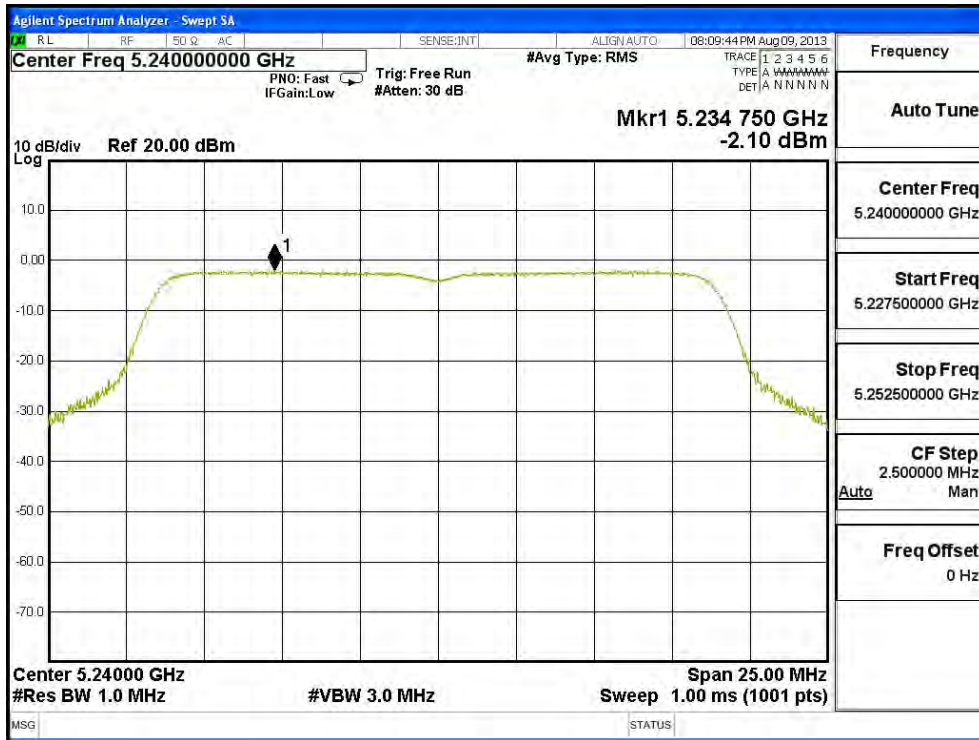



**Channel 36 – Chain B**

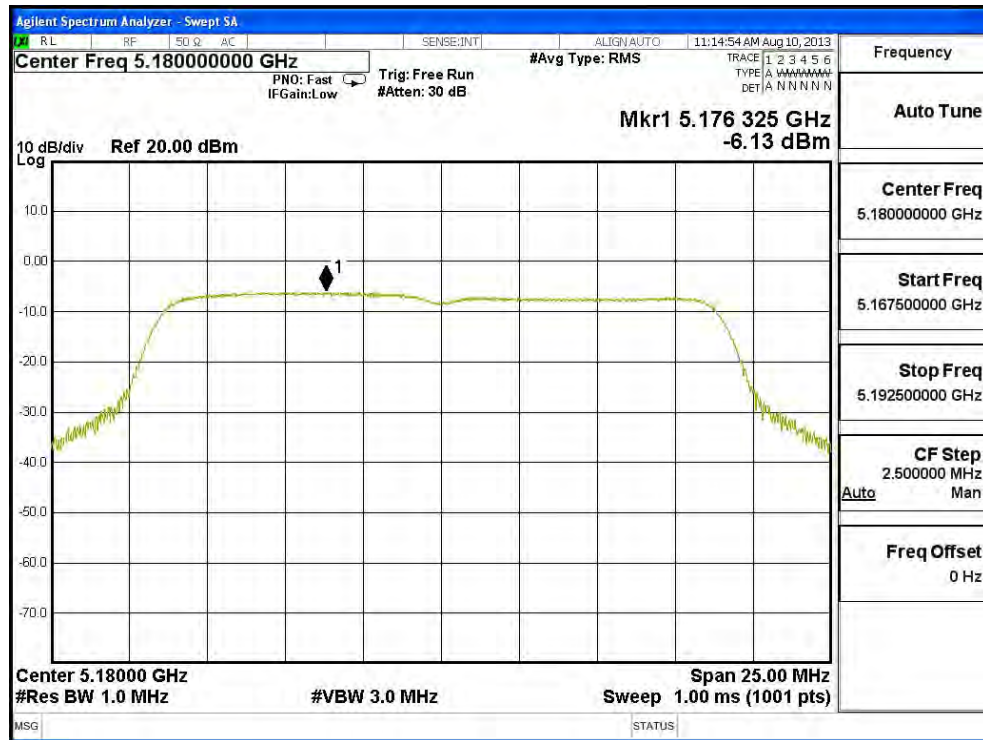

**Channel 44 – Chain B**

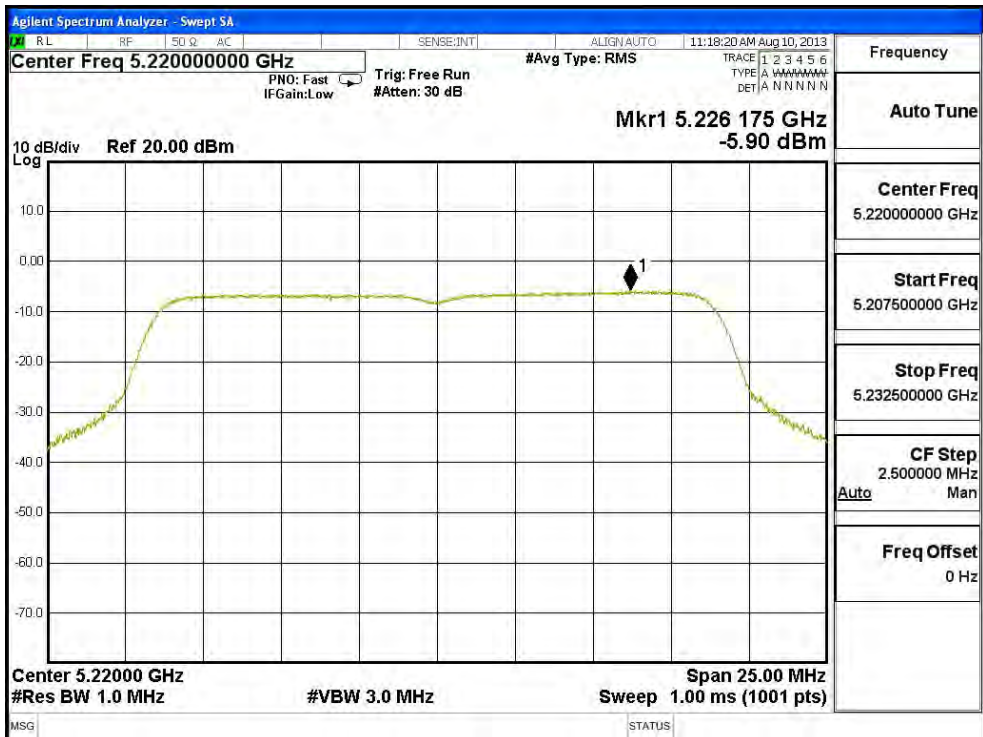

**Channel 48 – Chain B**



### Channel 36 – Chain C

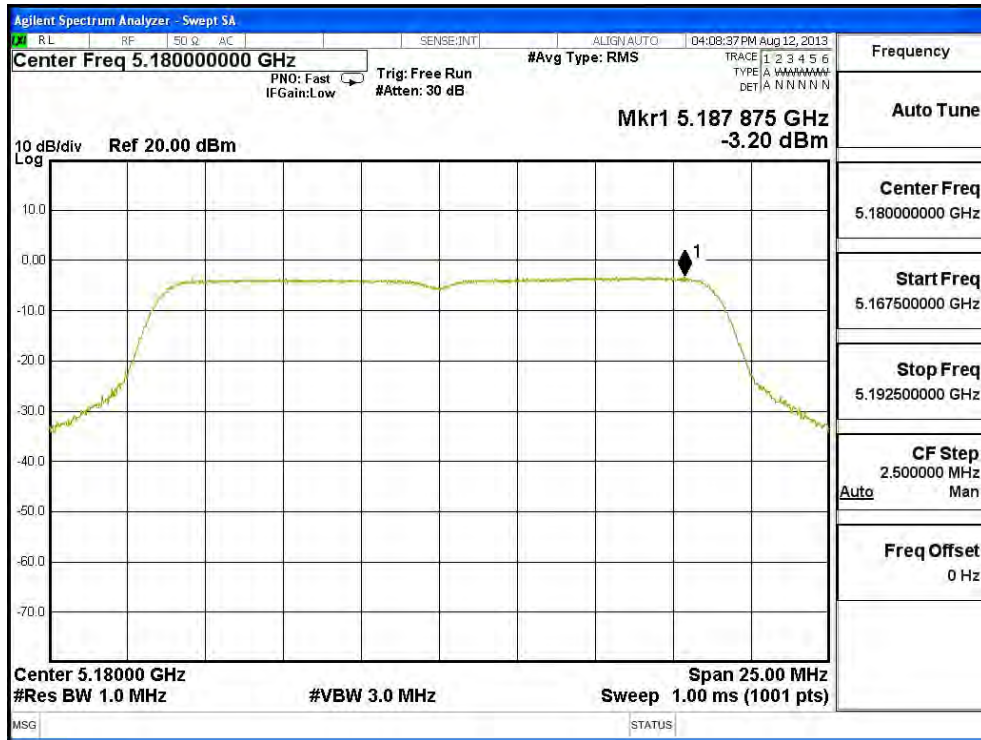

### Channel 44 – Chain C

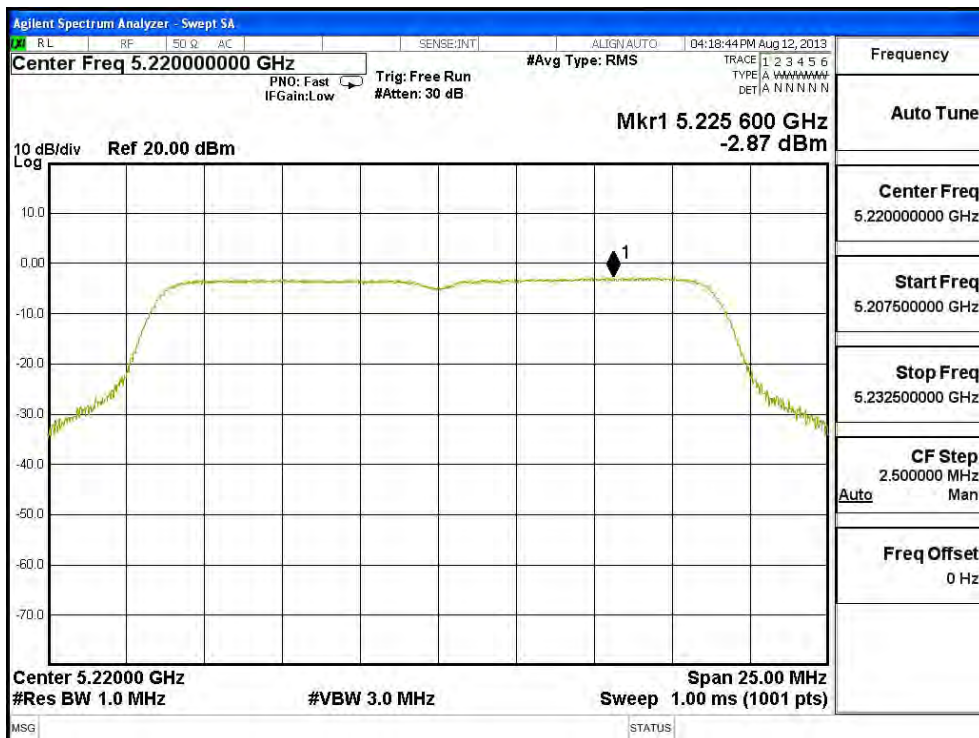

**Channel 48 – Chain C**

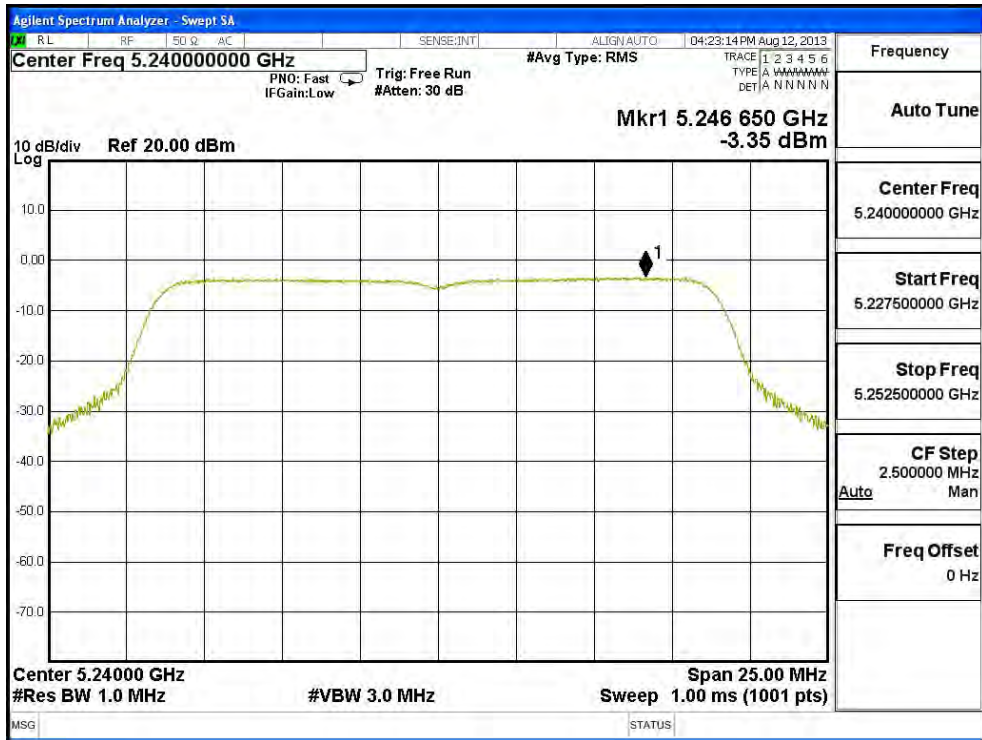

Product : SpectraGuard® Access Point / Sensor  
 Test Item : Peak Power Spectral Density  
 Test Site : No.3 OATS  
 Test Mode : Mode 6: Transmit (802.11n-40BW 45Mbps)(PIFA Antenna)

Channel No.	Frequency (MHz)	Chain (dBm)	PPSD/MHz (dBm)	Total PPSD/MHz (dBm)	Required Limit (dBm)	Result
38	5190	A	-4.920	-0.149	<4	Pass
		B	-7.770	-2.999	<4	Pass
		C	-5.060	-0.289	<4	Pass
46	5230	A	-5.170	-0.399	<4	Pass
		B	-7.920	-3.149	<4	Pass
		C	-5.210	-0.439	<4	Pass

Note 1: The quantity  $10 \cdot \log 3$  (two antennas) is added to the spectrum peak value according to document 662911 D01.

### Channel 38 – Chain A



### Channel 46 – Chain A

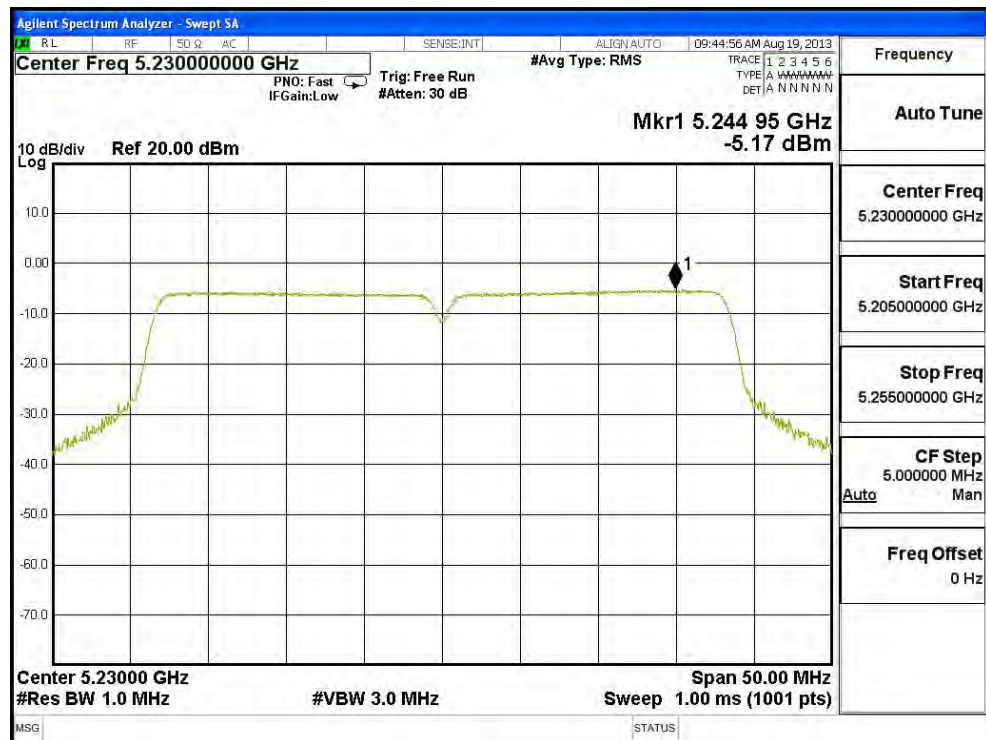

### Channel 38 – Chain B

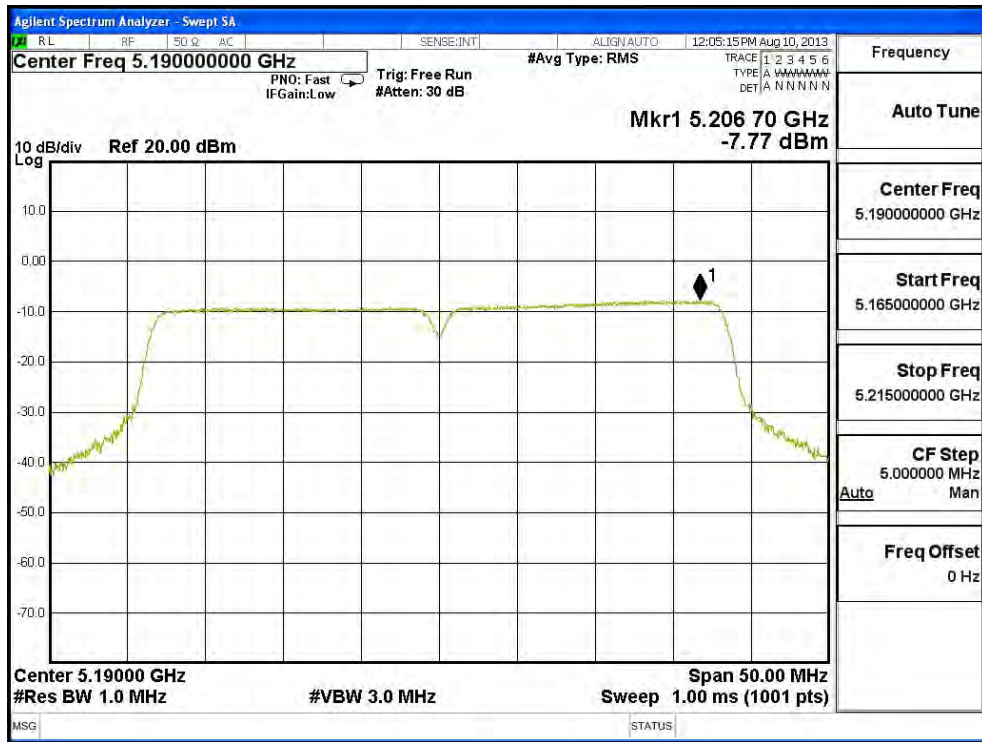

### Channel 46 – Chain B



### Channel 38 – Chain C



### Channel 46 – Chain C





**5. Peak Excursion**

**5.1. Test Equipment**

	Equipment	Manufacturer	Model No./Serial No.	Last Cal.
	Spectrum Analyzer	R&S	FSP40 / 100170	Jun, 2013
	Spectrum Analyzer	Agilent	E4407B / US39440758	Jun, 2013
X	Spectrum Analyzer	Agilent	N9010A / MY48030495	Apr., 2013

Note:

1. All equipments are calibrated with traceable calibrations. Each calibration is traceable to the national or international standards.
2. The test instruments marked with “X” are used to measure the final test results.

**5.2. Test Setup**

**Conduction Power Measurement**

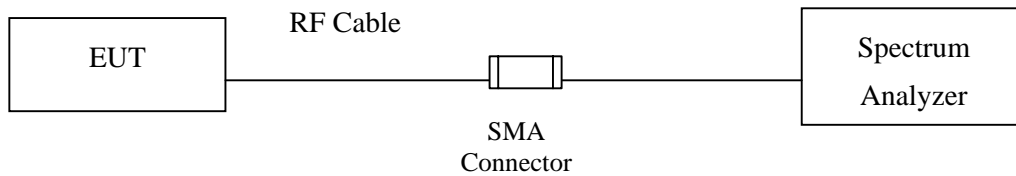

**5.3. Limits**

The ratio of the peak excursion of the modulation envelope (measured using a peak hold function) to the peak transmit power (measured as specified above) shall not exceed 13 dB across any 1 MHz bandwidth or the emission bandwidth whichever is less.

#### 5.4. Test Procedure

The EUT was setup to ANSI C63.10, 2009; tested to DTS test procedure of FCC KDB-789033 for compliance to FCC 47CFR Subpart E requirements.

Step 1: Set the spectrum analyzer or EMI receiver span to view the entire emission bandwidth.

Step 2: Find the maximum of the peak-max-hold spectrum.

(Set RBW = 1 MHz, VBW  $\geq$  3 MHz, Detector = peak, Trace mode = max-hold,

Allow the sweeps to continue until the trace stabilizes, Use the peak search function to find the peak of the spectrum.)

Step 3: Use the procedure found under KDB-789033 F) to measure the PPSD.

Step 4: Compute the ratio of the maximum of the peak-max-hold spectrum to the PPSD.

#### 5.5. Uncertainty

$\pm 1.27$  dB

### 5.6. Test Result of Peak Excursion

Product : SpectraGuard® Access Point / Sensor  
 Test Item : Peak Excursion  
 Test Site : No.3 OATS  
 Test Mode : Mode 1: Transmit (802.11 a-6Mbps)(Dipole Antenna)

#### CHAIN A

Channel No.	Frequency (MHz)	Data Rate (Mbps)	Measurement Level (dB)	Required Limit (dB)	Result
36	5180	MCS (0)	8.360	<13	Pass
		MCS (2)	9.240	<13	Pass
		MCS (4)	9.670	<13	Pass
		MCS (7)	8.980	<13	Pass

Channel 36:

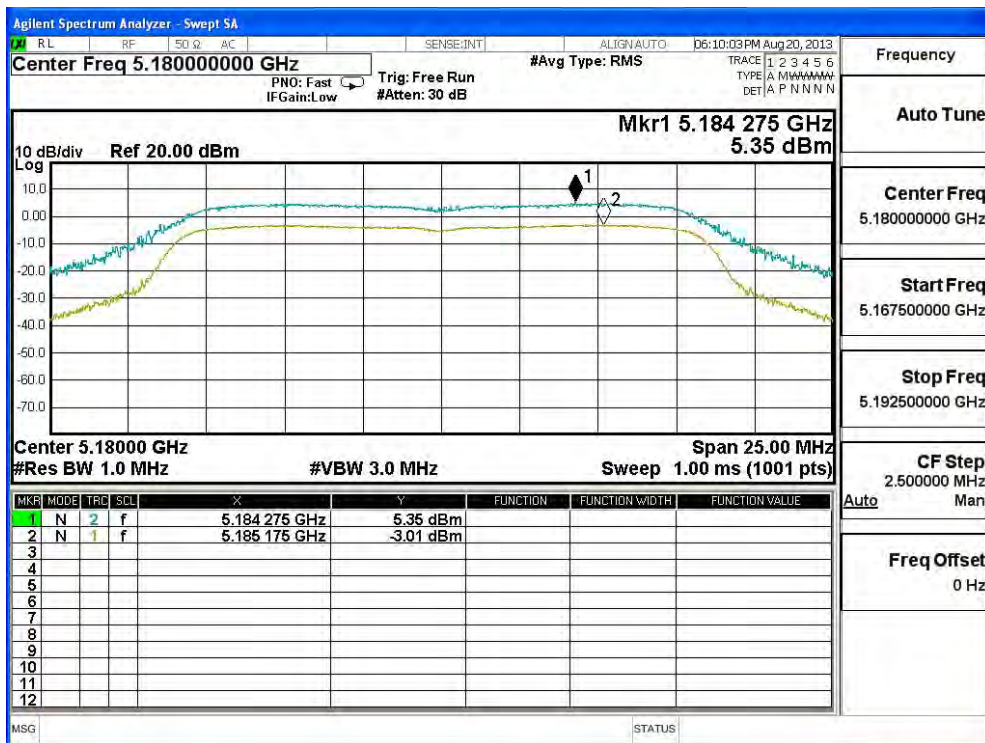

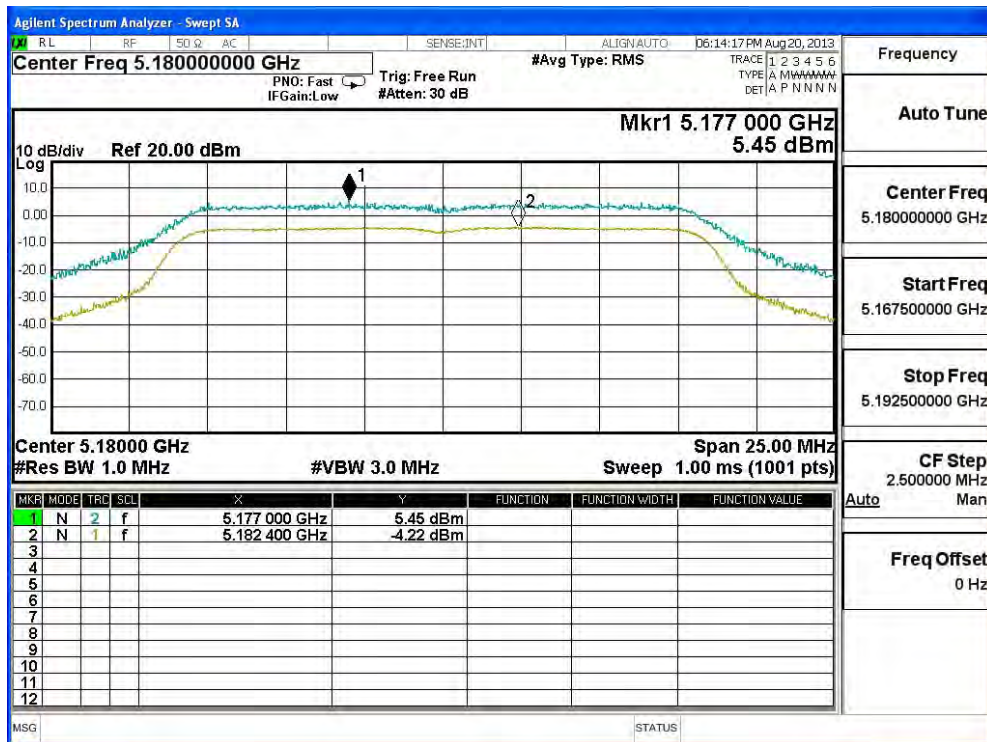
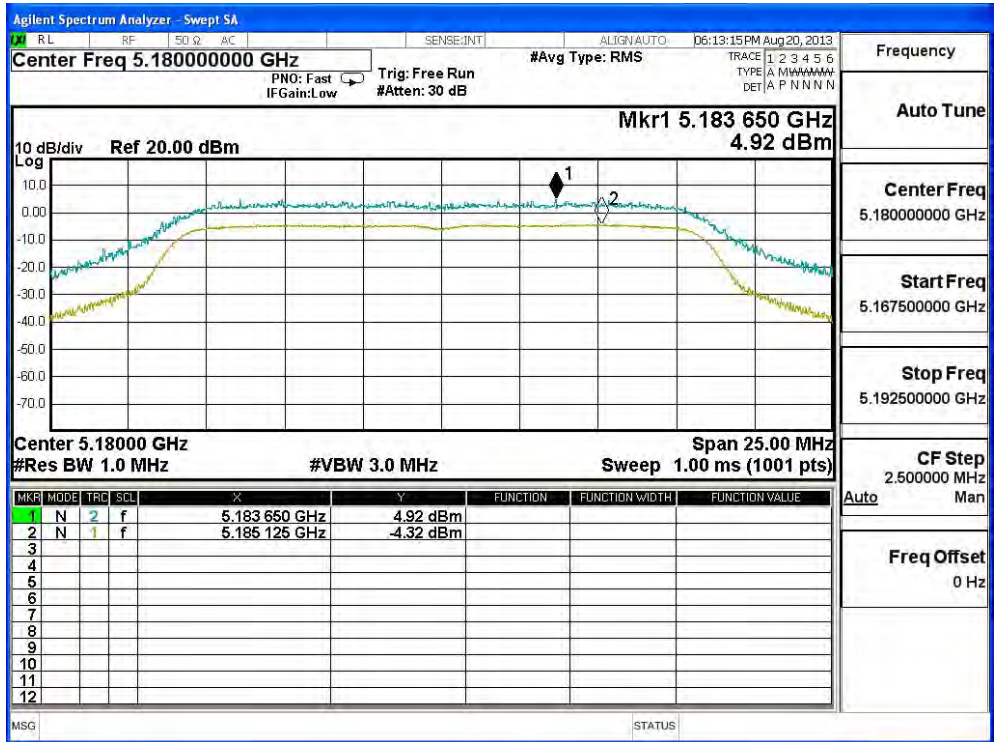

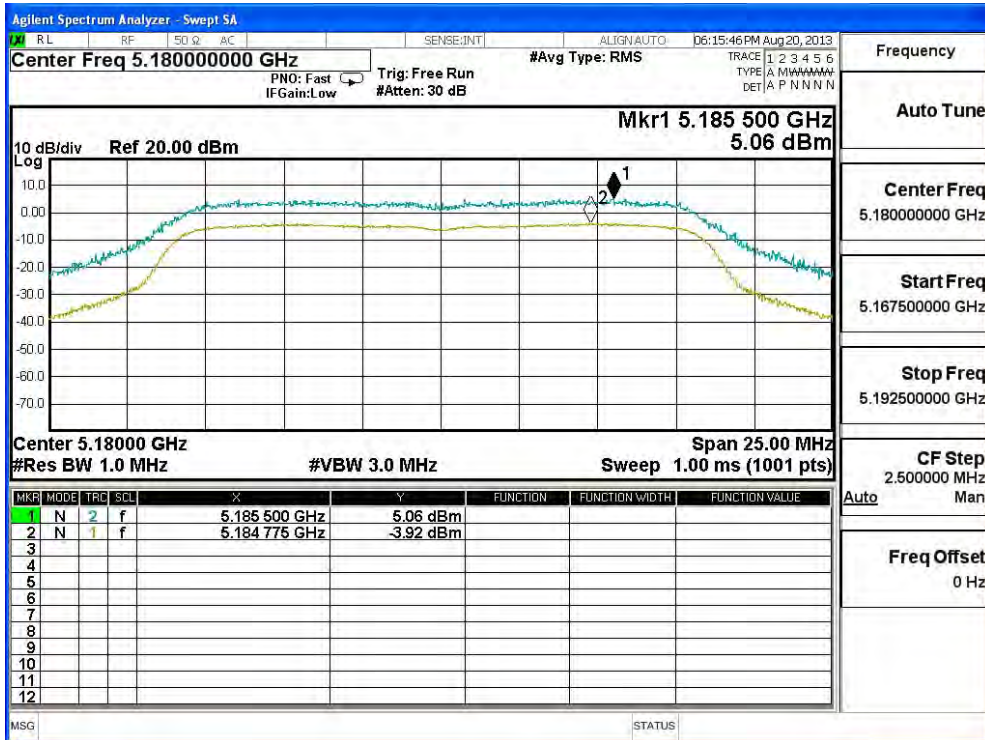

**CHAIN B**

Channel No.	Frequency (MHz)	Data Rate (Mbps)	Measurement Level (dB)	Required Limit (dB)	Result
36	5180	MCS (0)	9.410	<13	Pass
		MCS (2)	9.280	<13	Pass
		MCS (4)	8.970	<13	Pass
		MCS (7)	9.320	<13	Pass

**Channel 36:**

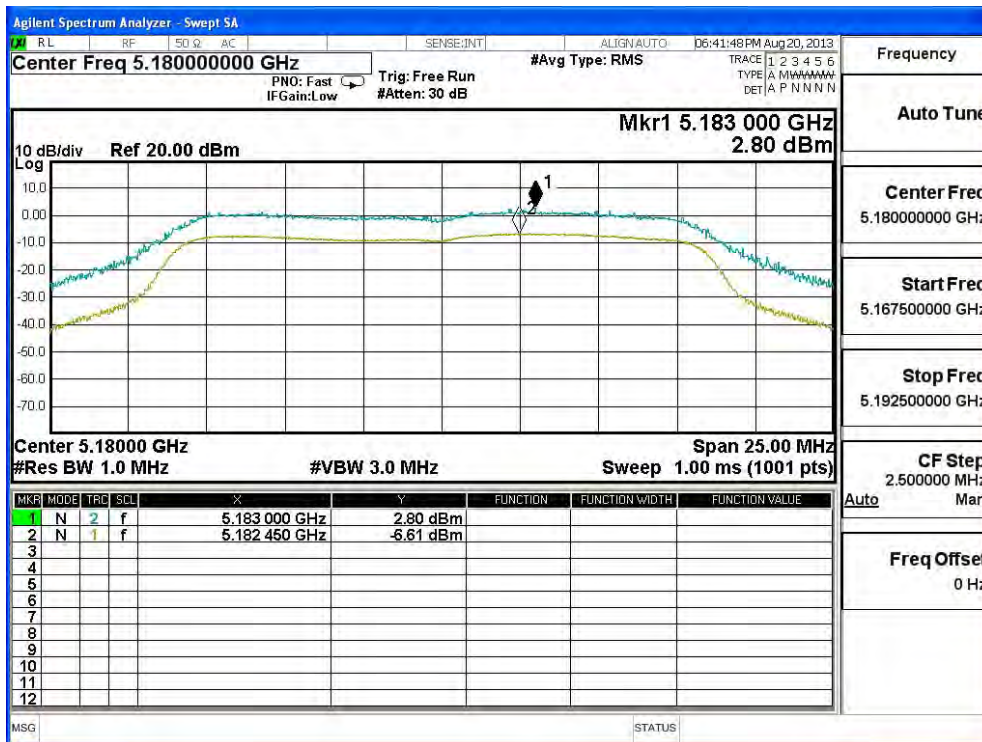

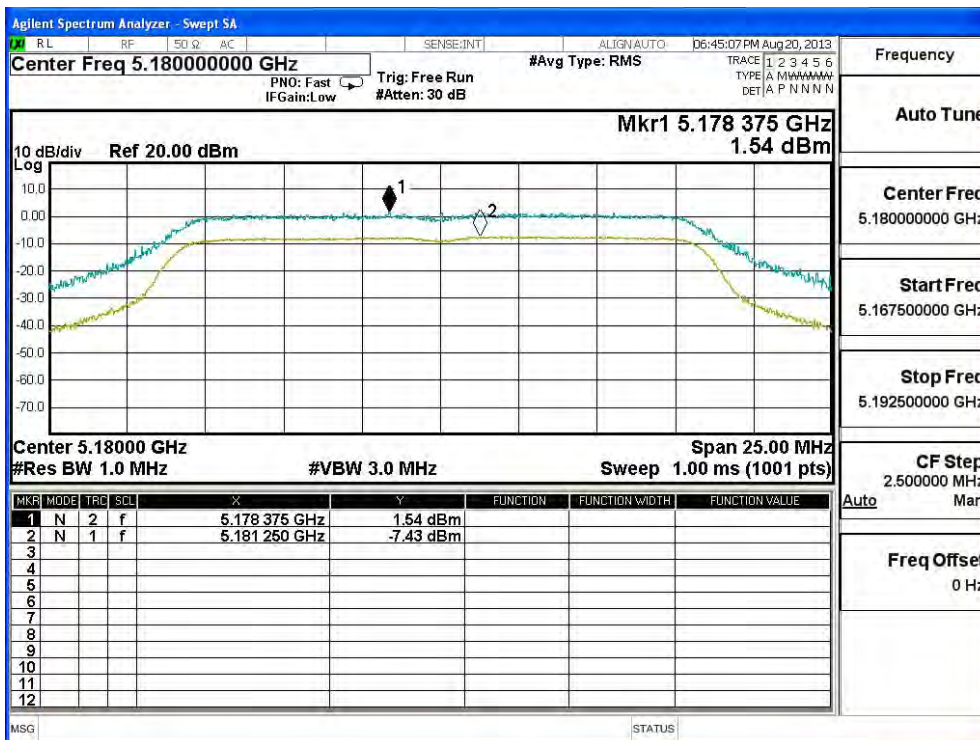
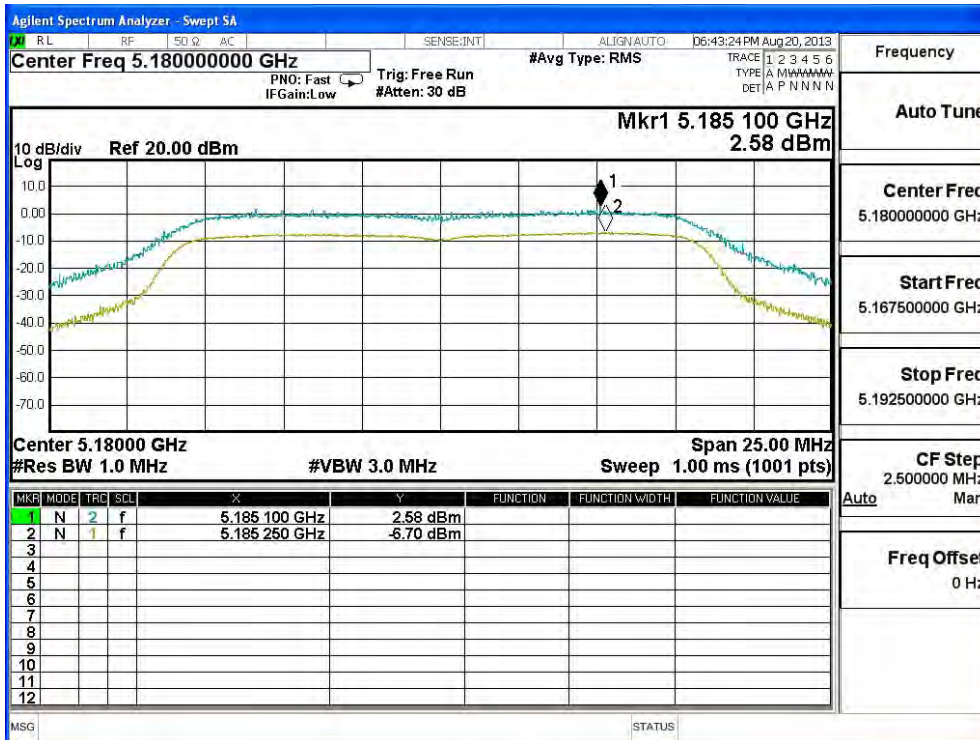

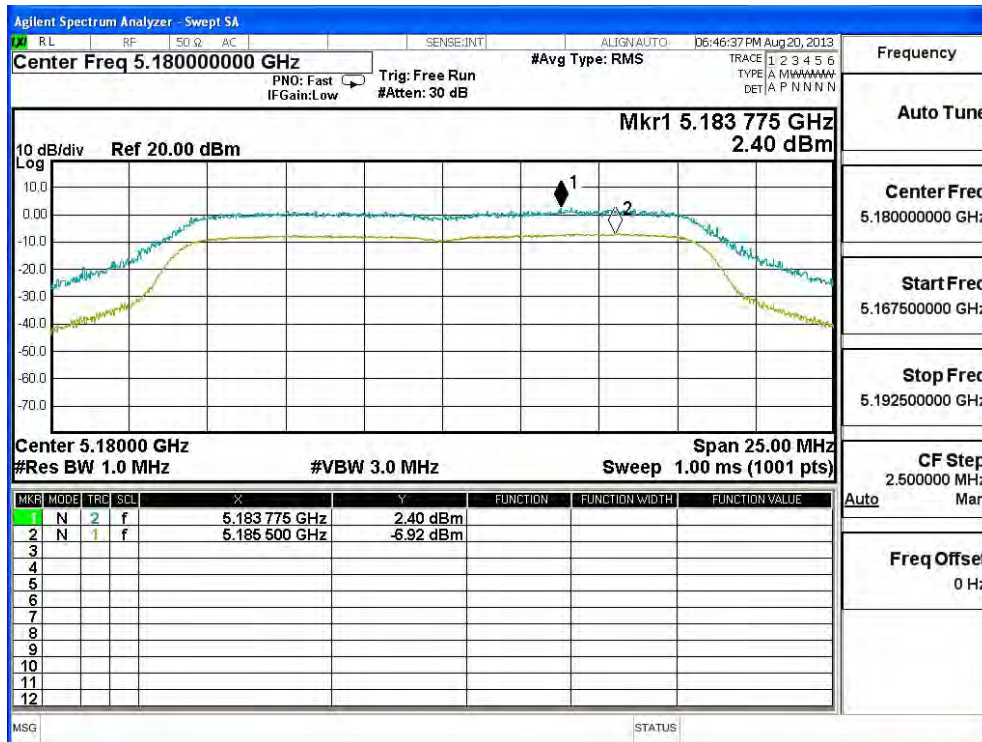



**CHAIN C**

Channel No.	Frequency (MHz)	Data Rate (Mbps)	Measurement Level (dB)	Required Limit (dB)	Result
36	5180	MCS (0)	9.620	<13	Pass
		MCS (2)	9.090	<13	Pass
		MCS (4)	9.160	<13	Pass
		MCS (7)	9.220	<13	Pass

**Channel 36:**

