



5453 Great America Parkway
Santa Clara, CA 95054
USA
408 547-5500
www.arista.com

Our social responsibility includes conducting business in a manner that minimizes our ecological impact on the environment and reducing waste in our supply chain. To that end, the Quick Start Guide and Safety Manual are available at www.arista.com.

Getting Started

Instructions on getting started with your new access point, including installation and initial configuration instructions, are available at <http://www.arista.com/en/support/product-documentation>

Other documents available at this location include:

You can access Arista documentation at <https://www.arista.com/en/support>

Documents available at this location include:

- Wireless Manager Appliance Quick Start Guide
- WiFi Regulatory Compliance Statements
- Safety and Compliance Guide
- User Manual

You may also download current software, as well as view FAQs, Warranty Information, Knowledge Base articles, Security Advisories, Software Licenses, and Field Notices at <https://www.arista.com/en/support>

Receiving and Inspecting the Equipment

Upon receiving the access point, inspect the shipping boxes and record any external damage. Retain the packing materials if you suspect that part of the shipment is damaged; the carrier may need to inspect them. If the boxes were not damaged in transit, unpack them carefully. Ensure that you do not discard any accessories that may be packaged in the same box as the main unit. Inspect the packing list and confirm that you received all listed items. Compare the packing list with your purchase order.

Obtaining Technical Assistance

Customers, partners, resellers, or distributors holding a valid Arista Service Contract can obtain technical support through these sources:

Email: support-wifi@arista.com. This is the easiest way to create a new service request. Include a detailed description of the problem and the output of "show tech-support".

Web: www.arista.com/en/support. A support case may be created through the support portal on our website.

FCC Compliance Statement

This equipment has been tested and found to comply with the limits for a Class B digital device, pursuant to Part 15 of the FCC Rules. These limits are designed to provide reasonable protection against harmful interference in a residential installation. This equipment generates, uses and can radiate radio frequency energy and, if not installed and used in accordance with the instructions, may cause harmful interference to radio communications. However, there is no guarantee that interference will not occur in a particular installation. If this equipment does cause harmful interference to radio or television reception, which can be determined by turning the equipment off and on, the user is encouraged to try to correct the interference by one or more of the following measures:

- Reorient or relocate the receiving antenna.
- Increase the separation between the equipment and receiver.
- Connect the equipment into an outlet on a circuit different from that to which the receiver is connected.
- Consult the dealer or an experienced radio/TV technician for help.

FCC Caution: Any changes or modifications not expressly approved by the party responsible for compliance could void the user's authority to operate this equipment.

This device complies with Part 15 of the FCC Rules. Operation is subject to the following two conditions: (1) This device may not cause harmful interference, and (2) this device must accept any interference received, including interference that may cause undesired operation.

This device is restricted to indoor use.

This device and its antenna(s) must not be co-located or operating in conjunction with any other antenna or transmitter.

FCC regulations restrict the operation of this device to indoor use only.

The operation of this device is prohibited on oil platforms, cars, trains, boats, and aircraft, except that operation of this device is permitted in large aircraft while flying above 10,000 feet.

Operation of transmitters in the 5.925-7.125 GHz band is prohibited for control of or communications with unmanned aircraft systems.

FCC Radiation Exposure Statement

This equipment complies with FCC radiation exposure limits set forth for an uncontrolled environment. This equipment should be installed and operated with minimum distance 20cm between the radiator & your body.

Note, Supplier's Declaration of Conformity §2.1077(a)(3)

Name: Arista Networks, Inc.

Address: 5453 Great America Parkway Santa Clara, CA 95054 USA

Telephone number: +1 (408)547-5500

Industry Canada Statement

This device contains licence-exempt transmitter(s)/receiver(s) that comply with Innovation, Science and Economic Development Canada's licence-exempt RSS(s). Operation is subject to the following two conditions:

1. This device may not cause interference.
 2. This device must accept any interference, including interference that may cause undesired operation of the device.
- L'émetteur/récepteur exempt de licence contenu dans le présent appareil est conforme aux CNR d'Innovation, Sciences et Développement économique Canada applicables aux appareils radio exempts de licence. L'exploitation est autorisée aux deux conditions suivantes :
1. L'appareil ne doit pas produire de brouillage;
 2. L'appareil doit accepter tout brouillage radioélectrique subi, même si le brouillage est susceptible d'en compromettre le fonctionnement.

The device for operation in the band 5150-5250 MHz is only for indoor use to reduce the potential for harmful interference to co-channel mobile satellite systems.

Les dispositifs fonctionnant dans la bande 5150-5250 MHz sont réservés uniquement pour une utilisation à l'intérieur afin de réduire les risques de brouillage préjudiciable aux systèmes de satellites mobiles utilisant les mêmes canaux.

Operation shall be limited to indoor use only.

leur utilisation doit être limitée à l'intérieur seulement.

Operation on oil platforms, automobiles, trains, maritime vessels and aircraft shall be prohibited except for on large aircraft flying above 3,048 m (10,000 ft).

leur utilisation à bord de plateformes de forage pétrolier, d'automobiles, de trains, de navires maritimes et d'aéronefs doit être interdite, sauf à bord d'un gros aéronef volant à plus de 3 048 m (10 000 pi) d'altitude.

Devices shall not be used for control of or communications with unmanned aircraft systems.

Les dispositifs ne doivent pas être utilisés pour commander des systèmes d'aéronef sans pilote ni pour communiquer avec de tels systèmes.

ISED Radiation Exposure Statement:

This equipment complies with ISED RSS-102 radiation exposure limits set forth for an uncontrolled environment. This equipment should be installed and operated with minimum distance 20cm between the radiator & your body.

Cet équipement est conforme aux limites d'exposition aux rayonnements IC établies pour un environnement non contrôlé. Cet équipement doit être installé et utilisé avec un minimum de 20cm de distance entre la source de rayonnement et votre corps.

The transmitter module may not be co-located with any other transmitter or antenna.

Le module émetteur peut ne pas être coimplanté avec un autre émetteur ou antenne.

The Country Code Selection feature is disabled for products marketed in the US/Canada.

CAN ICES-003(B) / NMB-003(B)

Taiwan NCC Compliance Statement

- 1.取得審驗證明之低功率射頻器材，非經核准，公司、商號或使用者均不得擅自變更頻率、加大功率或變更原設計之特性及功能。低功率射頻器材之使用不得影響飛航安全及干擾合法通信；經發現有干擾現象時，應立即停用，並改善至無干擾時方得繼續使用。前述合法通信，指依電信管理法規定作業之無線電通信。低功率射頻器材須忍受合法通信或工業、科學及醫療用電波輻射性電機設備之干擾。
- 2.應包含無線資訊傳輸設備避免影響附近雷達系統之操作。

Headquarters

408 547-5500

www.arista.com

Support

408 547-5502 866

476-0000

support@arista.com

Sales

408 547-5501

866 497-0000

sales@arista.com

PDOC-00249-01

Arista, Mojo, the Arista logo, and the Mojo logo are trademarks or registered trademarks of Arista Networks, Inc. and Mojo Networks, LLC. in the U.S. and other countries.

© 2023 Arista Networks, Inc. www.arista.com



AP-C330 Getting Started Guide

Note: For a fully functional access point (AP), please update its firmware to the latest version.

Package Contents

The C-330 package must contain the following components.



C-330

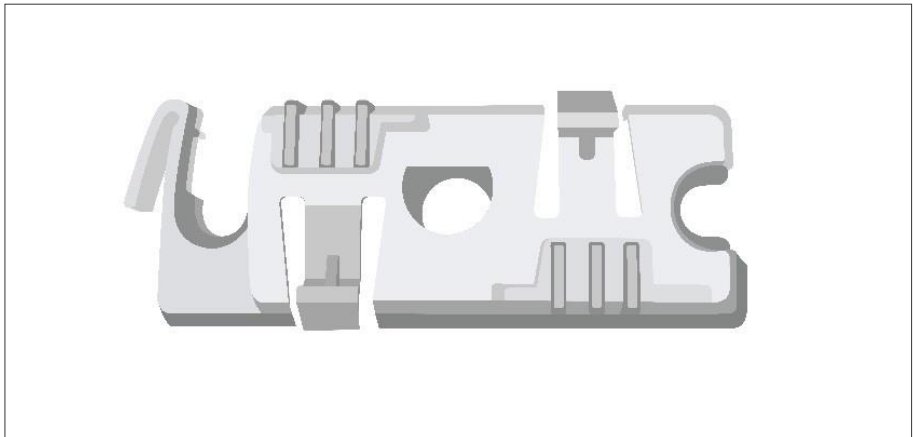

15/16" (24mm)

Mounting Bracket (MNT-AP-24MM)

Ceiling Mounting the C-330

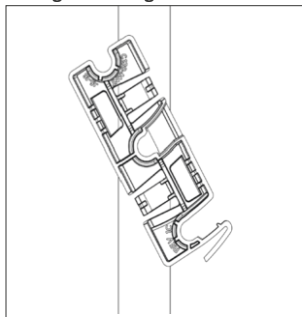

1. Affix bracket to T - Grid.

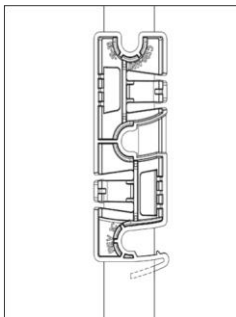

2. Rotate bracket to snap on to T- Grid.

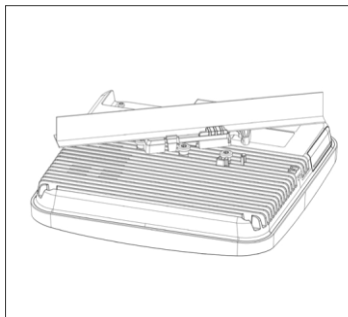

3. Place the first mounting post on the rear-side of the AP on to the lower notch of the bracket.

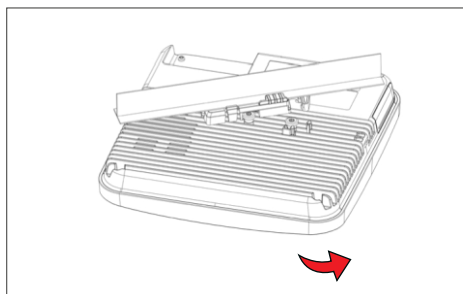

4. Rotate the AP such that the center mounting post fits in to the center notch on the bracket.

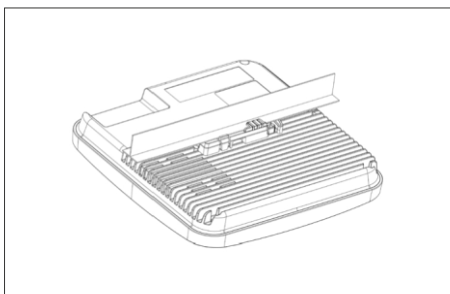

5. Ensure that all the mounting posts on the rear-side of the AP are snapped in to the respective notches on the bracket.

Getting the C-330 Online Step 1: Power up

Plug one end of an Ethernet cable into the PoE+ (802.3at) switch or injector and the other end into the LAN1 PoE+ port on the C-330. Ensure the PoE+ source you are using is turned ON, or use a compatible power adaptor (Arista SKU: PWR-AP-W4) to power the C-330.

Note: Both LAN1 and LAN2 have PoE support.

Warning: The C-330 is intended to be supplied with UL-listed PoE power source suitable for use at 40°C, and whose output meets LPS requirements or PS2, with a rating of 48V DC(0.5A minimum). If you are not using PoE+, ensure that you use only an AC power adaptor supported by the C-330 access point (AP). This product is intended to be supplied by a Listed Direct Plug-In Power Unit marked “Class 2”, Listed Power Adapter or DC power source marked “L.P.S.” (or “Limited Power Source”) and rated from 12 V DC, 2.5A minimum.

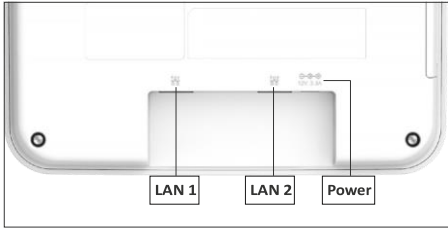

Step 2: Connect to the network

If you are using a PoE+ injector, make sure the data connection is plugged into a suitable switch port with proper network connectivity.

Note: If you are connecting only one Ethernet cable, you must connect it to the LAN1 port.

Step 3: Check the LED status

Power LED: The table below describes the states of the Power LED.

	Green	Orange
Solid	Running at full capability	Running at reduced capability
Blinking	Received IP address, but not connected to the server	Did not receive an IP address

Reduced capability indicates that the AP is getting less than the required maximum power from the PoE switch, i.e., 802.3af instead of 802.3at.

LAN1 LED: ON when the interface is up.

LAN2 LED: ON when the interface is up and either wired guest or link aggregation is configured. **Radio**

LEDs: ON when the corresponding radio is operational.

Troubleshooting

Using an 802.11ax access point on a 100 Mbps or a 1 Gbps Ethernet connection may cause WiFi performance issues. Use the 5 Gbps Ethernet uplink for best results.

1. Check whether the Ethernet cable is plugged into the correct port (PoE+) on the AP and the other end of the cable is plugged into an Ethernet jack or port on a switch that is turned ON.
2. If the AP did not receive a valid IP address from the DHCP server, check whether the DHCP server is ON and available on the VLAN/subnet to which the AP is connected. If the AP still fails to get a valid IP address, reboot the AP by pressing the reset button to see if the problem gets resolved.
3. If you are using Arista Cloud Services, then open the TCP port 443 (SSL). If you have an on-premises installation, then open the ports UDP 3851 and port 80. If you are using a Proxy, Web Accelerator or URL Content Filter in between the AP and the Internet, ensure that the settings allow communication between the AP and Arista Cloud Services. If your configuration requires you to specify an exact IP address or IP range for Arista Cloud Services, please contact Technical Support.