



FCC RADIO TEST REPORT

FCC ID : TOR-C130
Equipment : 802.11a/b/g/n/ac AP
Brand Name : MOJO , ARISTA
Model Name : C-130E
Applicant : Mojo Networks, Inc.
5453 Great America Parkway Santa Clara, CA
95054 United States
Manufacturer : Mojo Networks, Inc.
5453 Great America Parkway Santa Clara, CA
95054 United States
Standard : 47 CFR FCC Part 15.407

The product was received on Jan. 24, 2019, and testing was started from Jan. 31, 2019 and completed on Apr. 16, 2019. We, SPORTON INTERNATIONAL INC. EMC & Wireless Communications Laboratory, would like to declare that the tested sample has been evaluated in accordance with the procedures given in ANSI C63.10-2013 and shown compliance with the applicable technical standards.

The report must not be used by the client to claim product certification, approval, or endorsement by TAF or any agency of government.

The test results in this variant report apply exclusively to the tested model / sample. Without written approval of SPORTON INTERNATIONAL INC. EMC & Wireless Communications Laboratory, the test report shall not be reproduced except in full.



Approved by: Sam Chen

SPORTON INTERNATIONAL INC. EMC & Wireless Communications Laboratory
No. 52, Huaya 1st Rd., Guishan Dist., Taoyuan City, Taiwan (R.O.C.)



Table of Contents

History of this test report.....3

Summary of Test Result.....4

1 General Description5

1.1 Information.....5

1.2 Testing Applied Standards10

1.3 Testing Location Information.....10

1.4 Measurement Uncertainty10

2 Test Configuration of EUT11

2.1 Test Channel Mode11

2.2 The Worst Case Measurement Configuration.....13

2.3 EUT Operation during Test14

2.4 Accessories15

2.5 Support Equipment.....15

2.6 Test Setup Diagram17

3 Transmitter Test Result20

3.1 AC Power-line Conducted Emissions20

3.2 Emission Bandwidth.....22

3.3 Maximum Conducted Output Power23

3.4 Peak Power Spectral Density.....25

3.5 Unwanted Emissions.....28

4 Test Equipment and Calibration Data32

Appendix A. Test Results of AC Power-line Conducted Emissions

Appendix B. Test Results of Emission Bandwidth

Appendix C. Test Results of Maximum Conducted Output Power

Appendix D. Test Results of Peak Power Spectral Density

Appendix E. Test Results of Unwanted Emissions

Appendix F. Test Results of Radiated Emission Co-location

Appendix G. Test Photos

Photographs of EUT v01



Summary of Test Result

Report Clause	Ref Std. Clause	Test Items	Result (PASS/FAIL)	Remark
1.1.2	15.203	Antenna Requirement	PASS	-
3.1	15.207	AC Power-line Conducted Emissions	PASS	-
3.2	15.407(a)	Emission Bandwidth	PASS	-
3.3	15.407(a)	Maximum Conducted Output Power	PASS	-
3.4	15.407(a)	Peak Power Spectral Density	PASS	-
3.5	15.407(b)	Unwanted Emissions	PASS	-

Declaration of Conformity:

The test results with all measurement uncertainty excluded are presented in accordance with the regulation limits or requirements declared by manufacturers.

Comments and Explanations:

The declared of product specification for EUT presented in the report are provided by the manufacturer, and the manufacturer takes all the responsibilities for the accuracy of product specification.

Reviewed by: Sam Chen

Report Producer: Viola Huang



1 General Description

1.1 Information

1.1.1 RF General Information

Frequency Range (MHz)	IEEE Std. 802.11	Ch. Frequency (MHz)	Channel Number
5150-5250	a, n (HT20), ac (VHT20)	5180-5240	36-48 [4]
5725-5850		5745-5825	149-165 [5]
5150-5250	n (HT40), ac (VHT40)	5190-5230	38-46 [2]
5725-5850		5755-5795	151-159 [2]
5150-5250	ac (VHT80)	5210	42 [1]
5725-5850		5775	155 [1]

For Radio 2

Band	Mode	BWch (MHz)	Nant
5.15-5.25GHz	802.11a	20	4TX
5.15-5.25GHz	802.11n HT20	20	4TX
5.15-5.25GHz	802.11ac VHT20	20	4TX
5.15-5.25GHz	802.11n HT40	40	4TX
5.15-5.25GHz	802.11ac VHT40	40	4TX
5.15-5.25GHz	802.11ac VHT80	80	4TX
5.725-5.85GHz	802.11a	20	4TX
5.725-5.85GHz	802.11n HT20	20	4TX
5.725-5.85GHz	802.11ac VHT20	20	4TX
5.725-5.85GHz	802.11n HT40	40	4TX
5.725-5.85GHz	802.11ac VHT40	40	4TX
5.725-5.85GHz	802.11ac VHT80	80	4TX



For Radio 3

Band	Mode	BWch (MHz)	Nant
5.15-5.25GHz	802.11a	20	2TX
5.15-5.25GHz	802.11n HT20	20	2TX
5.15-5.25GHz	802.11ac VHT20	20	2TX
5.15-5.25GHz	802.11n HT40	40	2TX
5.15-5.25GHz	802.11ac VHT40	40	2TX
5.15-5.25GHz	802.11ac VHT80	80	2TX
5.725-5.85GHz	802.11a	20	2TX
5.725-5.85GHz	802.11n HT20	20	2TX
5.725-5.85GHz	802.11ac VHT20	20	2TX
5.725-5.85GHz	802.11n HT40	40	2TX
5.725-5.85GHz	802.11ac VHT40	40	2TX
5.725-5.85GHz	802.11ac VHT80	80	2TX

Note:

- ♦ 11a, HT20 and HT40 use a combination of OFDM-BPSK, QPSK, 16QAM, 64QAM modulation.
- ♦ VHT20, VHT40, VHT80 use a combination of OFDM-BPSK, QPSK, 16QAM, 64QAM, 256QAM modulation.
- ♦ BWch is the nominal channel bandwidth.
- ♦ Nss-Min is the minimum number of spatial streams.
- ♦ Nant is the number of outputs. e.g., 2(2,3) means have 2 outputs for port 2 and port 3. 2 means have 2 outputs for port 1 and port 2.



1.1.2 Antenna Information

Ant.	Port	Brand	P/N	Antenna Type	Connector	Gain (dBi)
1	1	WNC	XKAJ-N04	Dipole antenna	Reversed-SMA	Note 1
2	2	WNC	XKAJ-N04	Dipole antenna	Reversed-SMA	
3	3	WNC	XKAJ-N04	Dipole antenna	Reversed-SMA	
4	4	WNC	XKAJ-N04	Dipole antenna	Reversed-SMA	
5	1	WNC	XKAJ-N04	Dipole antenna	Reversed-SMA	
6	2	WNC	XKAJ-N04	Dipole antenna	Reversed-SMA	

Note 1:

Ant.	Port	Antenna Gain (dBi)				Cable Loss (dB)				True Gain (dBi)			
		Radio 1 (2.4G)	Radio 2 (5G)	Radio 3 (2.4G)	Radio 3 (5G)	Radio 1 (2.4G)	Radio 2 (5G)	Radio 3 (2.4G)	Radio 3 (5G)	Radio 1 (2.4G)	Radio 2 (5G)	Radio 3 (2.4G)	Radio 3 (5G)
1	1	4.32	5.04	-	-	1.5	3.5	-	-	2.82	1.54	-	-
2	2	4.32	5.04	-	-	1.5	3.5	-	-	2.82	1.54	-	-
3	3	4.32	5.04	-	-	1.5	3.5	-	-	2.82	1.54	-	-
4	4	4.32	5.04	-	-	1.5	3.5	-	-	2.82	1.54	-	-
5	1	-	-	4.32	5.04	-	-	1.0	1.8	-	-	3.32	3.24
6	2	-	-	4.32	5.04	-	-	1.0	1.8	-	-	3.32	3.24

Note 2: The above information was declared by manufacturer.

Note 3:

For radio 1 and radio 2 (4TX/4RX)

Port 1, Port 2, Port 3 and Port 4 can be used as transmitting/receiving antenna.

Port 1, Port 2, Port 3 and Port 4 could transmit/receive simultaneously.

For radio 3 (Scan radio) (2TX/2RX)

Port 1 and Port 2 can be used as transmitting/receiving antenna.

Port 1 and Port 2 could transmit/receive simultaneously.



1.1.3 Mode Test Duty Cycle

For radio 2

Mode	DC	DCF(dB)	T(s)	VBW(Hz) ≥ 1/T
802.11a	0.974	0.114	2.068m	1k
802.11ac VHT20	0.988	0.052	n/a (DC>=0.98)	n/a (DC>=0.98)
802.11ac VHT40	0.976	0.106	2.44m	1k
802.11ac VHT80	0.951	0.218	1.153m	1k

For radio 3

Mode	DC	DCF(dB)	T(s)	VBW(Hz) ≥ 1/T
802.11a	0.966	0.15	2.068m	1k
802.11ac VHT20	0.965	0.155	1.935m	1k
802.11ac VHT40	0.927	0.329	955u	3k
802.11ac VHT80	0.844	0.737	467.5u	3k

Note:

- ♦ DC is Duty Cycle.
- ♦ DCF is Duty Cycle Factor.

1.1.4 EUT Operational Condition

EUT Power Type	From Power Adapter or PoE			
Beamforming Function	<input type="checkbox"/>	With beamforming	<input checked="" type="checkbox"/>	Without beamforming
Function	<input type="checkbox"/>	Outdoor P2M	<input checked="" type="checkbox"/>	Indoor P2M
	<input type="checkbox"/>	Fixed P2P	<input type="checkbox"/>	Client
Test Software Version	QCARCT Ver3.0.211.0			

Note: The above information was declared by manufacturer.

1.1.5 Table for Multiple Listing

The brand names in the following table are all refer to the identical product.

Model Name	Brand Name	Description
C-130E	MOJO	The EUT has two brand names, all the brand are identical, the difference brand name served as marketing strategy.
	ARISTA	

1.1.6 Table for Radio Information

Radio	Function
Radio 1	2.4GHz
Radio 2	5GHz
Radio 3	2.4GHz / 5GHz (Scan Radio)



1.1.7 Table for Class II Change

This product is an extension of original one reported under Sporton project number: 641226-02AB

Below is the table for the change of the product with respect to the original one.

Modifications	Performance Checking
1. Adding EUT of external antenna. Based on above modification: 2. Adding model name: C-130E. 3. Adding six antennas (brand name: WNC, P/N number: XKAJ-N04).	All test item
4. Adding a brand name "ARISTA". 5. Removing the RJ-45 cable. 6. Removing the beamforming function. 7. Removing the 80+80 mode (5210+5775MHz). 8. Changing the applicant/manufacture address to "5453 Great America Parkway Santa Clara, CA 95054 United States" from "339 N. Bernardo Avenue, Suite #200 Mountain View, CA 94043 United States".	it's not necessary to test.



1.2 Testing Applied Standards

According to the specifications of the manufacturer, the EUT must comply with the requirements of the following standards:

- ◆ 47 CFR FCC Part 15
- ◆ ANSI C63.10-2013
- ◆ FCC KDB 789033 D02 v02r01
- ◆ FCC KDB 662911 D01 v02r01
- ◆ FCC KDB 412172 D01 v01r01

1.3 Testing Location Information

Testing Location		
<input type="checkbox"/>	HWA YA	ADD : No. 52, Huaya 1st Rd., Guishan Dist., Taoyuan City, Taiwan (R.O.C.) TEL : 886-3-327-3456 FAX : 886-3-327-0973
<input checked="" type="checkbox"/>	JHUBEI	ADD : No.8, Lane 724, Bo-ai St., Jhubei City, HsinChu County 302, Taiwan, R.O.C. TEL : 886-3-656-9065 FAX : 886-3-656-9085

Test Condition	Test Site No.	Test Engineer	Test Environment	Test Date
RF Conducted	TH01-CB	Owen Hsu	22°C~24°C / 53%~55%	Apr. 08, 2019~Apr. 16, 2019
Radiated below 1GHz	03CH01-CB	Stim Sung	24°C / 58%	Jan. 31, 2019~Feb. 01, 2019
Radiated above 1GHz	03CH01-CB	Bruce Yang	22°C~25°C / 56%~60%	Apr. 06, 2019~Apr. 15, 2019
AC Conduction	CO02-CB	Wei Li	25.3°C~25.6°C / 58.1%~58.4%	Feb. 11, 2019

Test site Designation No. TW0006 with FCC.
Test site registered number IC 4086B with Industry Canada.

1.4 Measurement Uncertainty

ISO/IEC 17025 requires that an estimate of the measurement uncertainties associated with the emissions test results be included in the report. The measurement uncertainties given below are based on a 95% confidence level (based on a coverage factor (k=2))

Test Items	Uncertainty	Remark
Conducted Emission (150kHz ~ 30MHz)	2.0 dB	Confidence levels of 95%
Radiated Emission (30MHz ~ 1,000MHz)	3.6 dB	Confidence levels of 95%
Radiated Emission (1GHz ~ 18GHz)	3.7 dB	Confidence levels of 95%
Radiated Emission (18GHz ~ 40GHz)	3.5 dB	Confidence levels of 95%
Conducted Emission	1.7 dB	Confidence levels of 95%
Output Power Measurement	1.33 dB	Confidence levels of 95%
Power Density Measurement	1.27 dB	Confidence levels of 95%
Bandwidth Measurement	9.74 x10 ⁻⁸	Confidence levels of 95%



2 Test Configuration of EUT

2.1 Test Channel Mode

For Radio 2

Mode	PowerSetting
802.11a_Nss1,(6Mbps)_4TX	-
5180MHz	20
5200MHz	20
5240MHz	20
5745MHz	21.5
5785MHz	21.5
5825MHz	21.5
802.11ac VHT20_Nss1,(MCS0)_4TX	-
5180MHz	20.5
5200MHz	20.5
5240MHz	20.5
5745MHz	21
5785MHz	21.5
5825MHz	21.5
802.11ac VHT40_Nss1,(MCS0)_4TX	-
5190MHz	19.5
5230MHz	20
5755MHz	21.5
5795MHz	21.5
802.11ac VHT80_Nss1,(MCS0)_4TX	-
5210MHz	17.5
5775MHz	19.5



For Radio 3

Mode	PowerSetting
802.11a_Nss1,(6Mbps)_2TX	-
5180MHz	16.5
5200MHz	22
5240MHz	19.5
5745MHz	30
5785MHz	30
5825MHz	30
802.11ac VHT20_Nss1,(MCS0)_2TX	-
5180MHz	16
5200MHz	23
5240MHz	19.5
5745MHz	30
5785MHz	30
5825MHz	30
802.11ac VHT40_Nss1,(MCS0)_2TX	-
5190MHz	16
5230MHz	20.5
5755MHz	25.5
5795MHz	30
802.11ac VHT80_Nss1,(MCS0)_2TX	-
5210MHz	13.5
5775MHz	22

Note:

- ♦ VHT20/VHT40 covers HT20/HT40, due to same modulation. The power setting for 802.11n HT20 and HT40 are the same or lower than VHT20 and VHT40.



2.2 The Worst Case Measurement Configuration

The Worst Case Mode for Following Conformance Tests	
Tests Item	AC power-line conducted emissions
Condition	AC power-line conducted measurement for line and neutral
Operating Mode	Normal Link
1	EUT + Radio 1 (2.4GHz) + Radio 2 (5GHz) + Radio 3 (2.4GHz) + adapter
2	EUT + Radio 1 (2.4GHz) + Radio 2 (5GHz) + Radio 3 (5GHz) + adapter
Mode 2 has been evaluated to be the worst case between Mode 1~2, thus measurement for Mode 3 will follow this same test mode.	
3	EUT + Radio 1 (2.4GHz) + Radio 2 (5GHz) + Radio 3 (5GHz) + PoE
Mode 3 generated the worst test result, so it was recorded in this report.	

The Worst Case Mode for Following Conformance Tests	
Tests Item	Emission Bandwidth Maximum Conducted Output Power Peak Power Spectral Density
Test Condition	Conducted measurement at transmit chains
1	Radio 2
2	Radio 3

The Worst Case Mode for Following Conformance Tests	
Tests Item	Unwanted Emissions
Test Condition	Radiated measurement If EUT consist of multiple antenna assembly (multiple antenna are used in EUT regardless of spatial multiplexing MIMO configuration), the radiated test should be performed with highest antenna gain of each antenna type.
Operating Mode < 1GHz	Normal Link
1	EUT in Z axis + Radio 1 (2.4GHz) + Radio 2 (5GHz) + Radio 3 (2.4GHz) + adapter
2	EUT in Y axis + Radio 1 (2.4GHz) + Radio 2 (5GHz) + Radio 3 (2.4GHz) + adapter
Mode 1 has been evaluated to be the worst case between Mode 1~2, thus measurement for Mode 3 will follow this same test mode.	
3	EUT in Z axis + Radio 1 (2.4GHz) + Radio 2 (5GHz) + Radio 3 (5GHz) + adapter
Mode 1 has been evaluated to be the worst case among Mode 1~3, thus measurement for Mode 4 will follow this same test mode.	
4	EUT in Z axis + Radio 1 (2.4GHz) + Radio 2 (5GHz) + Radio 3 (2.4GHz) + PoE
Mode 1 generated the worst test result, so it was recorded in this report.	



Operating Mode > 1GHz	CTX
	For Radio 2 The EUT was performed at Y axis and Z axis position and the worst case was found at Y axis. So the measurement will follow this same test configuration. For Radio 3 The EUT was performed at Y axis and Z axis position and the worst case was found at Z axis. So the measurement will follow this same test configuration.
1	Radio 2 (5GHz) - EUT in Y axis
2	Radio 3 (5GHz) - EUT in Z axis

The Worst Case Mode for Following Conformance Tests	
Tests Item	Simultaneous Transmission Analysis - Radiated Emission Co-location
Test Condition	Radiated measurement
Operating Mode	Normal Link
	EUT in Z axis has been evaluated to be the worst case at Unwanted Emissions test below 1GHz; thus, the measurement for Radiated Emission Co-location test will follow this same test configuration
1	EUT in Z axis - Radio 1 (2.4GHz) + Radio 2 (5GHz)

Refer to Appendix F for Radiated Emission Co-location.

The Worst Case Mode for Following Conformance Tests	
Tests Item	Simultaneous Transmission Analysis - Co-location RF Exposure Evaluation
Operating Mode	
1	Radio1 (2.4G) + Radio2 (5G) + Radio3 (2.4G)
2	Radio1 (2.4G) + Radio2 (5G) + Radio3 (5G)

Refer to Sporton Test Report No.: FA641226-21 for Co-location RF Exposure Evaluation.

Note:

1. The PoE information as below, The PoE is for measurement only and it would not be marketed.

Support Unit	Brand	Model	FCC ID
PoE	Frecom	PGSA34D01-540060	N/A

2. The console port can not be used by end user. It is generally used for debugging by professional installer.

2.3 EUT Operation during Test

For CTX Mode:

The EUT was programmed to be in continuously transmitting mode.

For Normal Link:

During the test, the EUT operation to normal function.



2.4 Accessories

Accessories			
Equipment Name	Brand Name	Model Name	Rating
Adapter	APD	WA-24Q12R	INPUT: 100-240V~,50-60Hz, 0.7A Max OUTPUT: 12V, 2A
Others			
US Plug*1			

2.5 Support Equipment

For AC Conduction:

Support Equipment				
No.	Equipment	Brand Name	Model Name	FCC ID
A	Flash disk3.0	Transcend	JetFlash-700	N/A
B	LAN0 NB	DELL	E6430	N/A
C	LAN1 NB	DELL	E6430	N/A
D	5G NB	DELL	E6430	N/A
E	2.4G NB	DELL	E6430	N/A
F	2.4/5G NB	DELL	E6430	N/A
G	PoE	Frecom	PGSA34D01-540060	N/A

For Radiated (below 1GHz):

Support Equipment				
No.	Equipment	Brand Name	Model Name	FCC ID
A	NB	Apple	Mac Book	N/A
B	NB	Apple	Mac Book	N/A
C	NB	Apple	Mac Book	N/A
D	NB	DELL	E4300	N/A
E	NB	DELL	E4300	N/A
F	Flash disk	Silicon Power	I-Series	N/A



For Radiated (above 1GHz):

Support Equipment				
No.	Equipment	Brand Name	Model Name	FCC ID
A	NB	DELL	E4300	N/A

For RF Conducted:

Support Equipment				
No.	Equipment	Brand Name	Model Name	FCC ID
A	NB	DELL	E4300	N/A

2.6 Test Setup Diagram

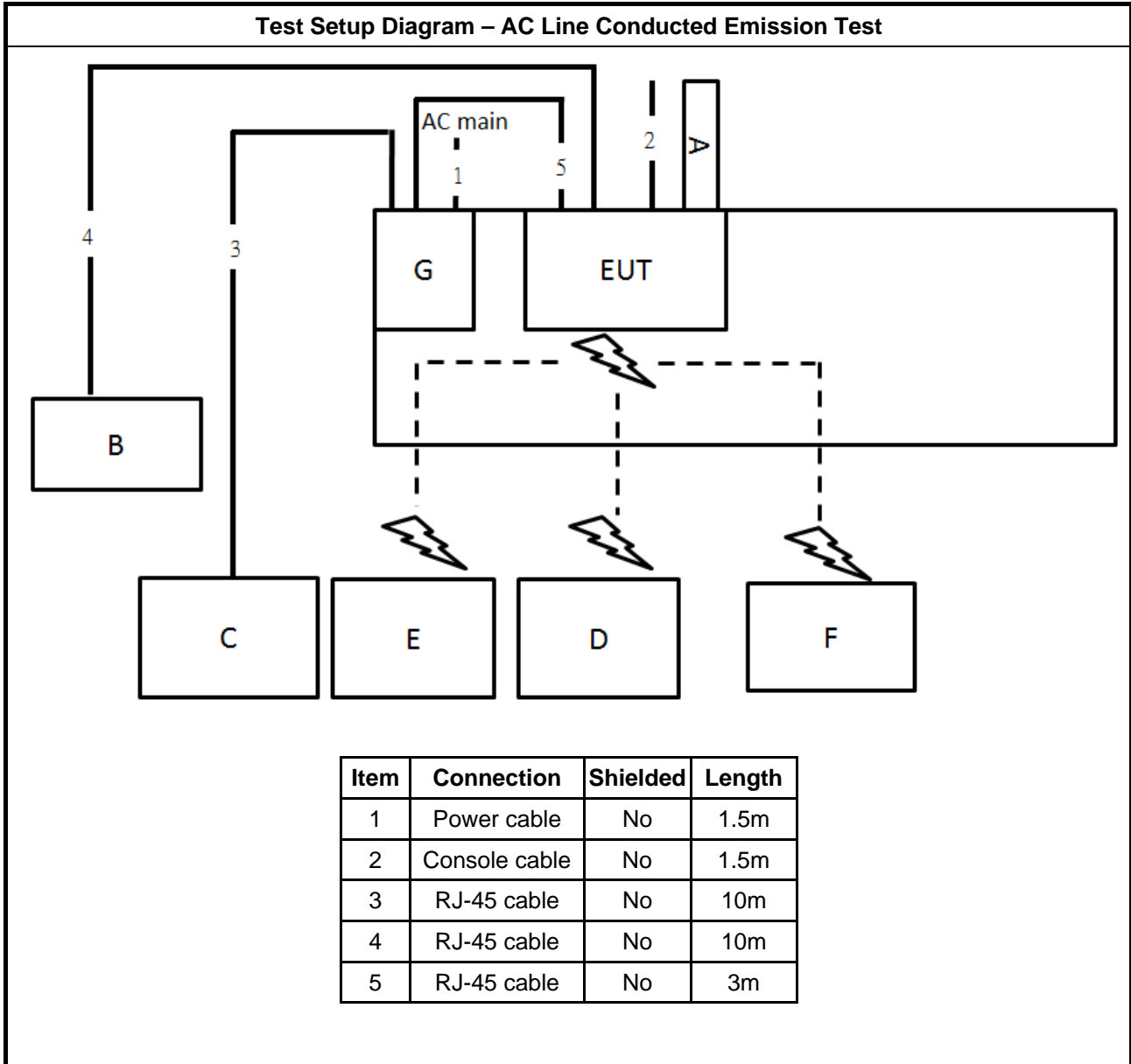



Test Setup Diagram - Radiated Test < 1GHz

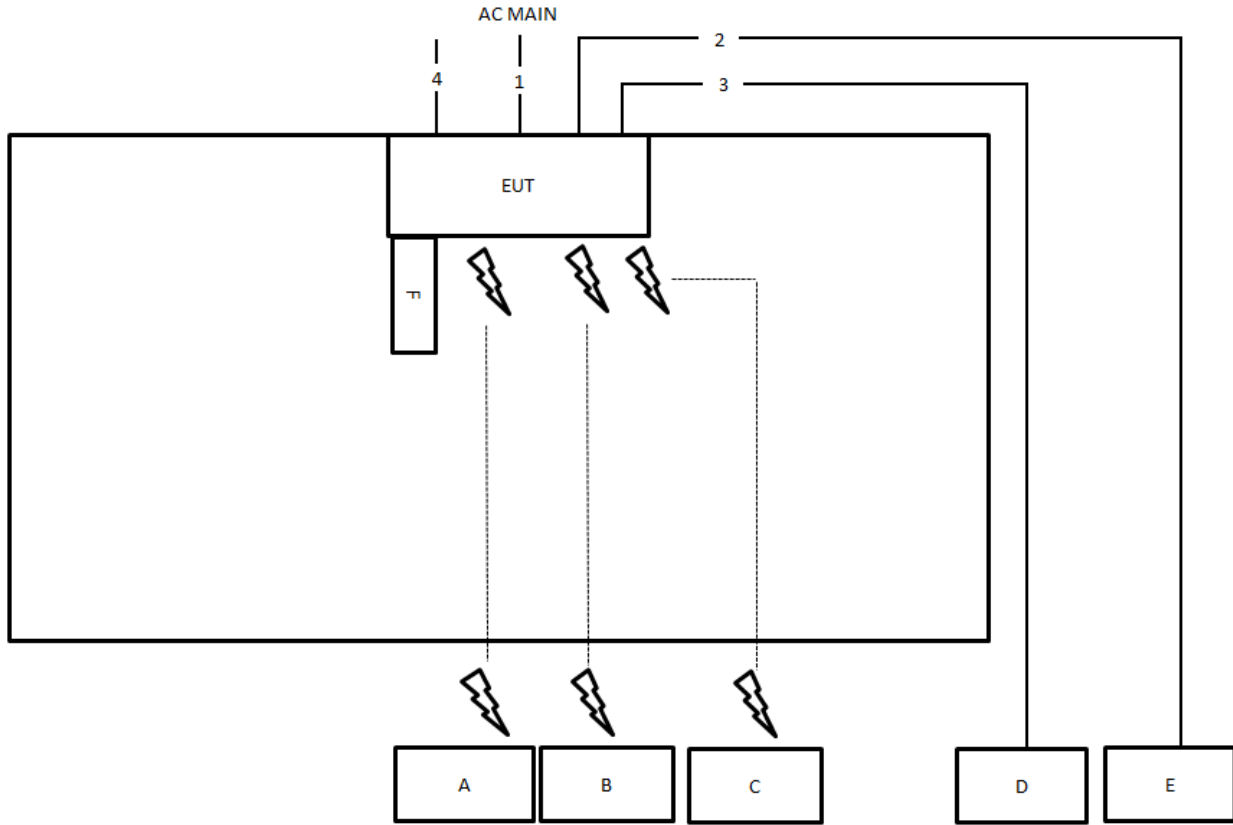

Item	Connection	Shielded	Length
1	Power cable	No	1.5m
2	RJ-45 cable	No	10m
3	RJ-45 cable	No	10m
4	Console cable	No	1.5m

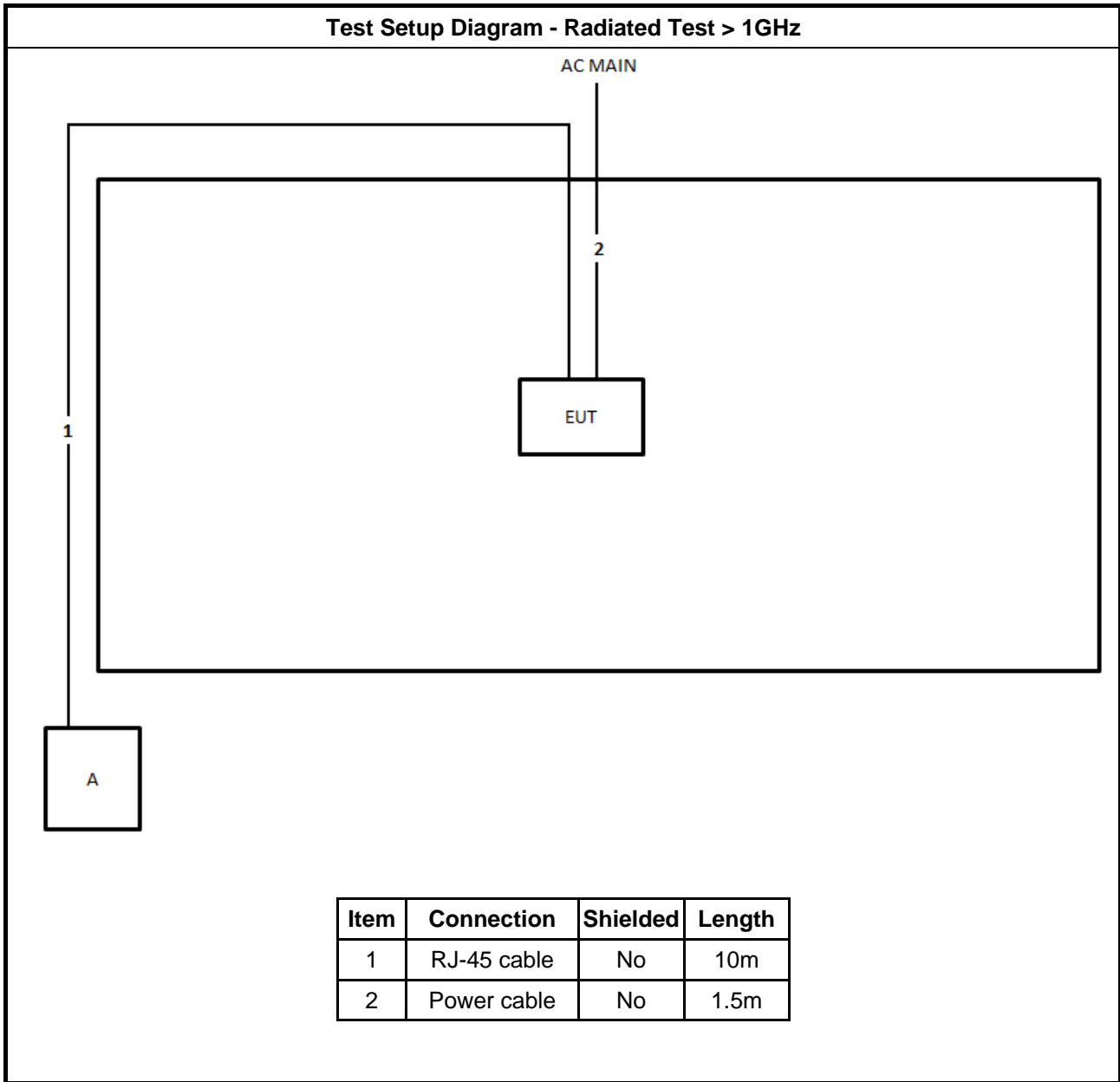



3 Transmitter Test Result

3.1 AC Power-line Conducted Emissions

3.1.1 AC Power-line Conducted Emissions Limit

AC Power-line Conducted Emissions Limit		
Frequency Emission (MHz)	Quasi-Peak	Average
0.15-0.5	66 - 56 *	56 - 46 *
0.5-5	56	46
5-30	60	50

Note 1: * Decreases with the logarithm of the frequency.

3.1.2 Measuring Instruments

Refer a test equipment and calibration data table in this test report.

3.1.3 Test Procedures

Test Method
<input checked="" type="checkbox"/> Refer as ANSI C63.10-2013, clause 6.2 for AC power-line conducted emissions.

3.1.4 Test Setup

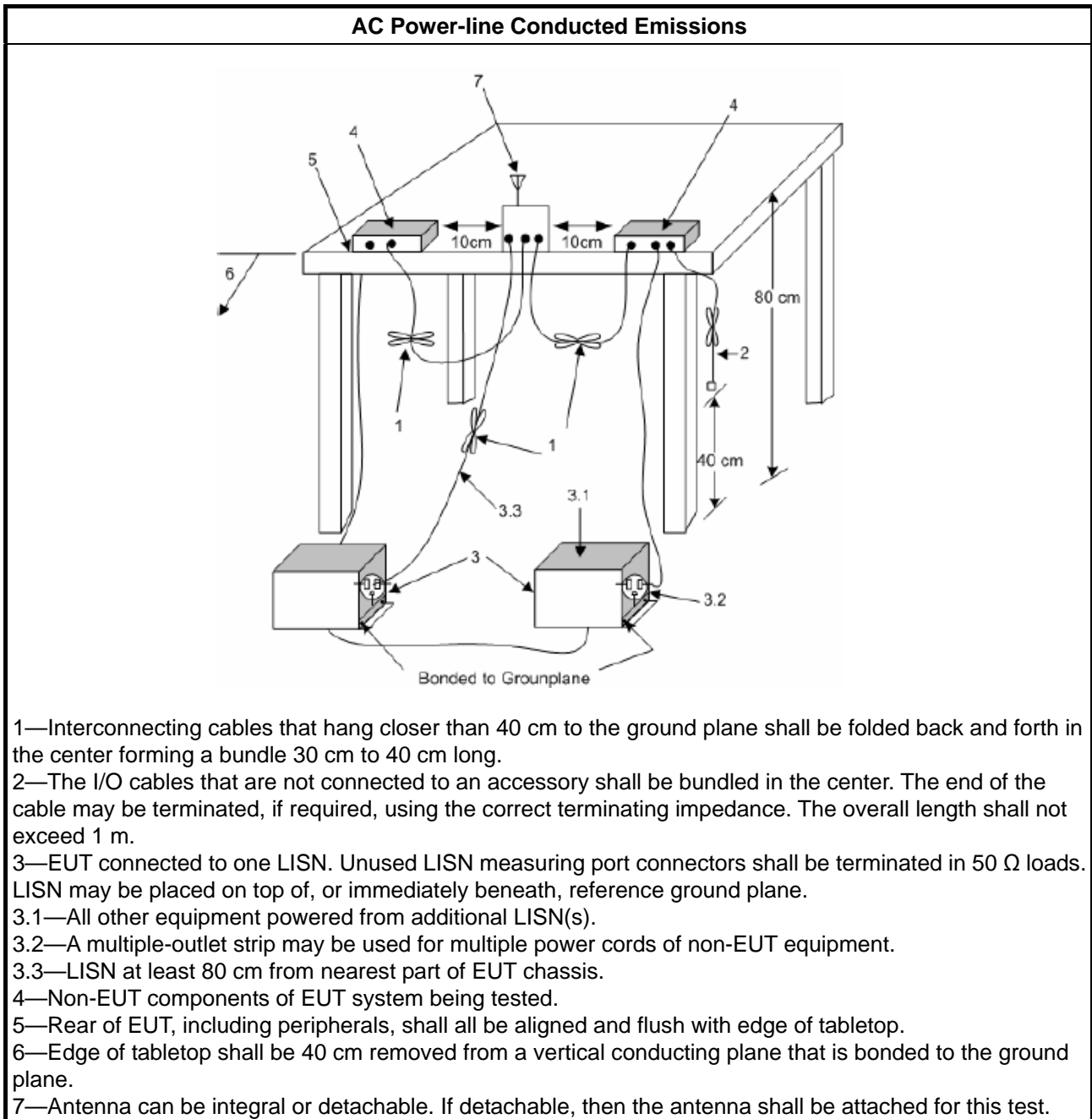

3.1.5 Test Result of AC Power-line Conducted Emissions

Refer as Appendix A

3.2 Emission Bandwidth

3.2.1 Emission Bandwidth Limit

Emission Bandwidth Limit	
UNII Devices	
<input checked="" type="checkbox"/>	For the 5.15-5.25 GHz band, N/A
<input type="checkbox"/>	For the 5.25-5.35 GHz band, the maximum conducted output power shall not exceed the lesser of 250 mW or 11 dBm + 10 log B, where B is the 26 dB emission bandwidth in MHz.
<input type="checkbox"/>	For the 5.47-5.725 GHz band, the maximum conducted output power shall not exceed the lesser of 250 mW or 11 dBm + 10 log B, where B is the 26 dB emission bandwidth in MHz.
<input checked="" type="checkbox"/>	For the 5.725-5.85 GHz band, 6 dB emission bandwidth \geq 500kHz.
LE-LAN Devices	
<input type="checkbox"/>	For the band 5.15-5.25 GHz, the maximum e.i.r.p. shall not exceed 200 mW or 10 + 10 log B, dBm, whichever power is less. B is the 99% emission bandwidth in MHz.
<input type="checkbox"/>	For the 5.25-5.35 GHz band, the maximum e.i.r.p. shall not exceed 1.0 W or 17 + 10 log B, dBm, whichever power is less. B is the 99% emission bandwidth in MHz
<input type="checkbox"/>	For the 5.47-5.6 GHz band and 5.65-5.725 GHz band, the maximum e.i.r.p. shall not exceed 1.0 W or 17 + 10 log B, dBm, whichever power is less. B is the 99% emission bandwidth in MHz
<input type="checkbox"/>	For the 5.725-5.85 GHz band, 6 dB emission bandwidth \geq 500kHz.

3.2.2 Measuring Instruments

Refer a test equipment and calibration data table in this test report.

3.2.3 Test Procedures

Test Method							
<ul style="list-style-type: none"> ▪ For the emission bandwidth shall be measured using one of the options below: <table border="1" style="width: 100%; border-collapse: collapse;"> <tr> <td style="width: 30px;"><input checked="" type="checkbox"/></td> <td>Refer as FCC KDB 789033, clause C for EBW and clause D for OBW measurement.</td> </tr> <tr> <td><input type="checkbox"/></td> <td>Refer as ANSI C63.10, clause 6.9.1 for occupied bandwidth testing.</td> </tr> <tr> <td><input type="checkbox"/></td> <td>Refer as IC RSS-Gen, clause 4.6 for bandwidth testing.</td> </tr> </table> 		<input checked="" type="checkbox"/>	Refer as FCC KDB 789033, clause C for EBW and clause D for OBW measurement.	<input type="checkbox"/>	Refer as ANSI C63.10, clause 6.9.1 for occupied bandwidth testing.	<input type="checkbox"/>	Refer as IC RSS-Gen, clause 4.6 for bandwidth testing.
<input checked="" type="checkbox"/>	Refer as FCC KDB 789033, clause C for EBW and clause D for OBW measurement.						
<input type="checkbox"/>	Refer as ANSI C63.10, clause 6.9.1 for occupied bandwidth testing.						
<input type="checkbox"/>	Refer as IC RSS-Gen, clause 4.6 for bandwidth testing.						

3.2.4 Test Setup

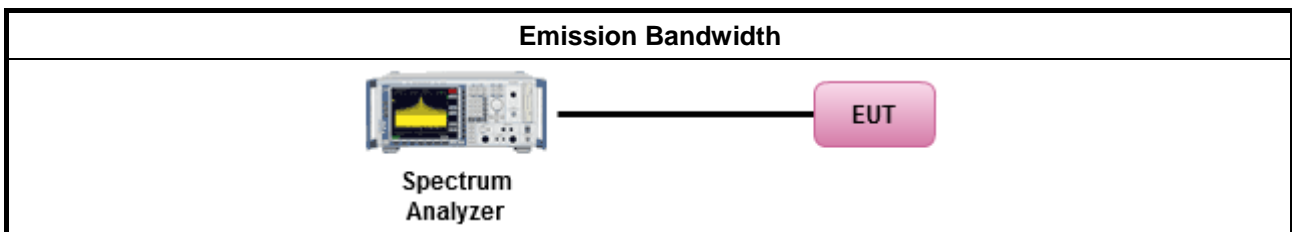

3.2.5 Test Result of Emission Bandwidth

Refer as Appendix B



3.3 Maximum Conducted Output Power

3.3.1 Maximum Conducted Output Power Limit

Maximum Conducted Output Power Limit	
UNII Devices	
<input checked="" type="checkbox"/> For the 5.15-5.25 GHz band:	
	<ul style="list-style-type: none"> ▪ Outdoor AP: the maximum conducted output power (P_{Out}) shall not exceed the lesser of 1 W. If $G_{TX} > 6$ dBi, then $P_{Out} = 30 - (G_{TX} - 6)$. e.i.r.p. at any elevation angle above 30 degrees $\leq 125mW$ [21dBm] ▪ Indoor AP: the maximum conducted output power (P_{Out}) shall not exceed the lesser of 1 W. If $G_{TX} > 6$ dBi, then $P_{Out} = 30 - (G_{TX} - 6)$ ▪ Point-to-point AP: the maximum conducted output power (P_{Out}) shall not exceed the lesser of 1 W. If $G_{TX} > 23$ dBi, then $P_{Out} = 30 - (G_{TX} - 23)$. ▪ Mobile or Portable Client: the maximum conducted output power (P_{Out}) shall not exceed the lesser of 250 mW. If $G_{TX} > 6$ dBi, then $P_{Out} = 24 - (G_{TX} - 6)$.
<input type="checkbox"/> For the 5.25-5.35 GHz band, the maximum conducted output power (P_{Out}) shall not exceed the lesser of 250 mW or 11 dBm + 10 log B, where B is the 26 dB emission bandwidth in MHz. If $G_{TX} > 6$ dBi, then $P_{Out} = 24 - (G_{TX} - 6)$.	
<input type="checkbox"/> For the 5.47-5.725 GHz band, the maximum conducted output power (P_{Out}) shall not exceed the lesser of 250 mW or 11 dBm + 10 log B, where B is the 26 dB emission bandwidth in MHz. If $G_{TX} > 6$ dBi, then $P_{Out} = 24 - (G_{TX} - 6)$.	
<input checked="" type="checkbox"/> For the 5.725-5.85 GHz band:	
	<ul style="list-style-type: none"> ▪ Point-to-multipoint systems (P2M): the maximum conducted output power (P_{Out}) shall not exceed the lesser of 1 W. If $G_{TX} > 6$ dBi, then $P_{Out} = 30 - (G_{TX} - 6)$. ▪ Point-to-point systems (P2P): the maximum conducted output power (P_{Out}) shall not exceed the lesser of 1 W.
LE-LAN Devices	
<input type="checkbox"/> For the 5.15-5.25 GHz band, the maximum e.i.r.p. shall not exceed 200 mW or 10 + 10 log B, dBm, whichever power is less. B is the 99% emission bandwidth in MHz.	
<input type="checkbox"/> For the 5.25-5.35 GHz band, the maximum e.i.r.p. shall not exceed 1.0 W or 17 + 10 log B, dBm, whichever power is less. B is the 99% emission bandwidth in MHz	
<input type="checkbox"/> For the 5.47-5.6 GHz band and 5.65-5.725 GHz band, the maximum e.i.r.p. shall not exceed 1.0 W or 17 + 10 log B, dBm, whichever power is less. B is the 99% emission bandwidth in MHz	
<input type="checkbox"/> For the 5.725-5.85 GHz band:	
	<ul style="list-style-type: none"> ▪ Point-to-multipoint systems (P2M): the maximum conducted output power (P_{Out}) shall not exceed the lesser of 1 W. If $G_{TX} > 6$ dBi, then $P_{Out} = 30 - (G_{TX} - 6)$. ▪ Point-to-point systems (P2P): the maximum conducted output power (P_{Out}) shall not exceed the lesser of 1 W.
P_{Out} = maximum conducted output power in dBm, G_{TX} = the maximum transmitting antenna directional gain in dBi.	

3.3.2 Measuring Instruments

Refer a test equipment and calibration data table in this test report.

3.3.3 Test Procedures

Test Method	
<ul style="list-style-type: none"> ▪ Maximum Conducted Output Power 	
Average over on/off periods with duty factor	
<input type="checkbox"/>	Refer as FCC KDB 789033, clause E Method SA-2 (spectral trace averaging).
<input type="checkbox"/>	Refer as FCC KDB 789033, clause E Method SA-2 Alt. (RMS detection with slow sweep speed)
Wideband RF power meter and average over on/off periods with duty factor	
<input checked="" type="checkbox"/>	Refer as FCC KDB 789033, clause E Method PM-G (using an RF average power meter).
<ul style="list-style-type: none"> ▪ For conducted measurement. 	
<ul style="list-style-type: none"> ▪ If the EUT supports multiple transmit chains using options given below: Refer as FCC KDB 662911, In-band power measurements. Using the measure-and-sum approach, measured all transmit ports individually. Sum the power (in linear power units e.g., mW) of all ports for each individual sample and save them. 	
<ul style="list-style-type: none"> ▪ If multiple transmit chains, EIRP calculation could be following as methods: $P_{total} = P_1 + P_2 + \dots + P_n$ (calculated in linear unit [mW] and transfer to log unit [dBm]) $EIRP_{total} = P_{total} + DG$ 	

3.3.4 Test Setup

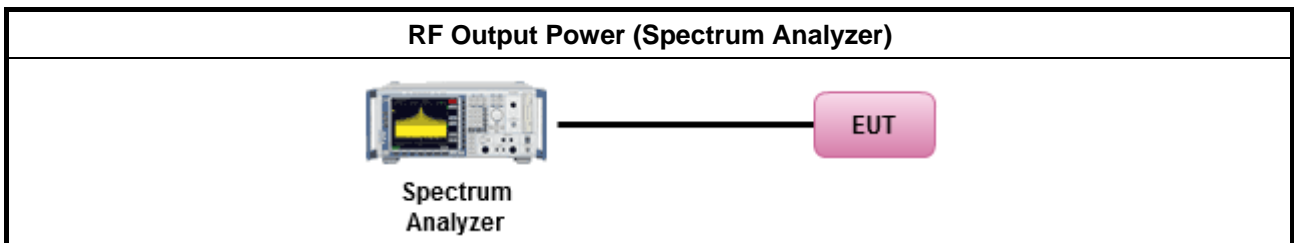

3.3.5 Test Result of Maximum Conducted Output Power

Refer as Appendix C



3.4 Peak Power Spectral Density

3.4.1 Peak Power Spectral Density Limit

Peak Power Spectral Density Limit	
UNII Devices	
<input checked="" type="checkbox"/> For the 5.15-5.25 GHz band:	
	<ul style="list-style-type: none"> ▪ Outdoor AP: the peak power spectral density (PPSD) shall not exceed the lesser of 17dBm/MHz. If $G_{TX} > 6$ dBi, then $P_{Out} = 17 - (G_{TX} - 6)$. ▪ Indoor AP: the peak power spectral density (PPSD) shall not exceed the lesser of 17dBm/MHz. If $G_{TX} > 6$ dBi, then $P_{Out} = 17 - (G_{TX} - 6)$. ▪ Point-to-point AP: the peak power spectral density (PPSD) shall not exceed the lesser of 17dBm/MHz. If $G_{TX} > 23$ dBi, then $P_{Out} = 17 - (G_{TX} - 23)$. ▪ Mobile or Portable Client: the peak power spectral density (PPSD) ≤ 11 dBm/MHz. If $G_{TX} > 6$ dBi, then $PPSD = 11 - (G_{TX} - 6)$.
<input type="checkbox"/> For the 5.25-5.35 GHz band, the peak power spectral density (PPSD) ≤ 11 dBm/MHz. If $G_{TX} > 6$ dBi, then $PPSD = 11 - (G_{TX} - 6)$.	
<input type="checkbox"/> For the 5.47-5.725 GHz band, the peak power spectral density (PPSD) ≤ 11 dBm/MHz. If $G_{TX} > 6$ dBi, then $PPSD = 11 - (G_{TX} - 6)$.	
<input checked="" type="checkbox"/> For the 5.725-5.85 GHz band:	
	<ul style="list-style-type: none"> ▪ Point-to-multipoint systems (P2M): the peak power spectral density (PPSD) ≤ 30 dBm/500kHz. If $G_{TX} > 6$ dBi, then $PPSD = 30 - (G_{TX} - 6)$. ▪ Point-to-point systems (P2P): the peak power spectral density (PPSD) ≤ 30 dBm/500kHz.
LE-LAN Devices	
<input type="checkbox"/> For the 5.15-5.25 GHz band, the e.i.r.p. peak power spectral density (PPSD) ≤ 10 dBm/MHz.	
<input type="checkbox"/> For the 5.25-5.35 GHz band, the peak power spectral density (PPSD) ≤ 11 dBm/MHz.	
	<ul style="list-style-type: none"> ▪ e.i.r.p. greater than 200 mW shall comply with the following e.i.r.p. at different elevations, where θ is the angle above the local horizontal plane (of the Earth) as shown below: -13 dBW/MHz for $0^\circ \leq \theta < 8^\circ$; $-13 - 0.716 (\theta - 8)$ dBW/MHz for $8^\circ \leq \theta < 40^\circ$ -35.9 - 1.22 ($\theta - 40$) dBW/MHz for $40^\circ \leq \theta \leq 45^\circ$; -42 dBW/MHz for $\theta > 45^\circ$
<input type="checkbox"/> For the 5.47-5.6 GHz band and 5.65-5.725 GHz band, the peak power spectral density (PPSD) ≤ 11 dBm/MHz.	
<input type="checkbox"/> For the 5.725-5.85 GHz band:	
	<ul style="list-style-type: none"> ▪ Point-to-multipoint systems (P2M): the peak power spectral density (PPSD) ≤ 30 dBm/500kHz. If $G_{TX} > 6$ dBi, then $PPSD = 30 - (G_{TX} - 6)$. ▪ Point-to-point systems (P2P): the peak power spectral density (PPSD) ≤ 30 dBm/500kHz.
<p>PPSD = peak power spectral density that he same method as used to determine the conducted output power shall be used to determine the power spectral density. And power spectral density in dBm/MHz G_{TX} = the maximum transmitting antenna directional gain in dBi.</p>	



3.4.2 Measuring Instruments

Refer a test equipment and calibration data table in this test report.

3.4.3 Test Procedures

Test Method	
<ul style="list-style-type: none"> ▪ Peak power spectral density procedures that the same method as used to determine the conducted output power shall be used to determine the peak power spectral density and use the peak search function on the spectrum analyzer to find the peak of the spectrum. For the peak power spectral density shall be measured using below options: 	
<input type="checkbox"/>	Refer as FCC KDB 789033, F)5) power spectral density can be measured using resolution bandwidths < 1 MHz provided that the results are integrated over 1 MHz bandwidth
[duty cycle ≥ 98% or external video / power trigger]	
<input checked="" type="checkbox"/>	Refer as FCC KDB 789033, clause E Method SA-1 (spectral trace averaging).
<input type="checkbox"/>	Refer as FCC KDB 789033, clause E Method SA-1 Alt. (RMS detection with slow sweep speed)
duty cycle < 98% and average over on/off periods with duty factor	
<input checked="" type="checkbox"/>	Refer as FCC KDB 789033, clause E Method SA-2 (spectral trace averaging).
<input type="checkbox"/>	Refer as FCC KDB 789033, clause E Method SA-2 Alt. (RMS detection with slow sweep speed)
<ul style="list-style-type: none"> ▪ For conducted measurement. 	
<ul style="list-style-type: none"> ▪ If the EUT supports multiple transmit chains using options given below: 	
<input checked="" type="checkbox"/>	Option 1: Measure and sum the spectra across the outputs. Refer as FCC KDB 662911, In-band power spectral density (PSD). Sample all transmit ports simultaneously using a spectrum analyzer for each transmit port. Where the trace bin-by-bin of each transmit port summing can be performed. (i.e., in the first spectral bin of output 1 is summed with that in the first spectral bin of output 2 and that from the first spectral bin of output 3, and so on up to the NTX output to obtain the value for the first frequency bin of the summed spectrum.). Add up the amplitude (power) values for the different transmit chains and use this as the new data trace.
<input type="checkbox"/>	Option 2: Measure and sum spectral maxima across the outputs. With this technique, spectra are measured at each output of the device at the required resolution bandwidth. The maximum value (peak) of each spectrum is determined. These maximum values are then summed mathematically in linear power units across the outputs. These operations shall be performed separately over frequency spans that have different out-of-band or spurious emission limits,
<input type="checkbox"/>	Option 3: Measure and add 10 log(N) dB, where N is the number of transmit chains. Refer as FCC KDB 662911, In-band power spectral density (PSD). Performed at each transmit chains and each transmit chains shall be compared with the limit have been reduced with 10 log(N). Or each transmit chains shall be add 10 log(N) to compared with the limit.
<ul style="list-style-type: none"> ▪ If multiple transmit chains, EIRP PPSD calculation could be following as methods: $PPSD_{total} = PPSD_1 + PPSD_2 + \dots + PPSD_n$ (calculated in linear unit [mW] and transfer to log unit [dBm]) $EIRP_{total} = PPSD_{total} + DG$ 	

3.4.4 Test Setup

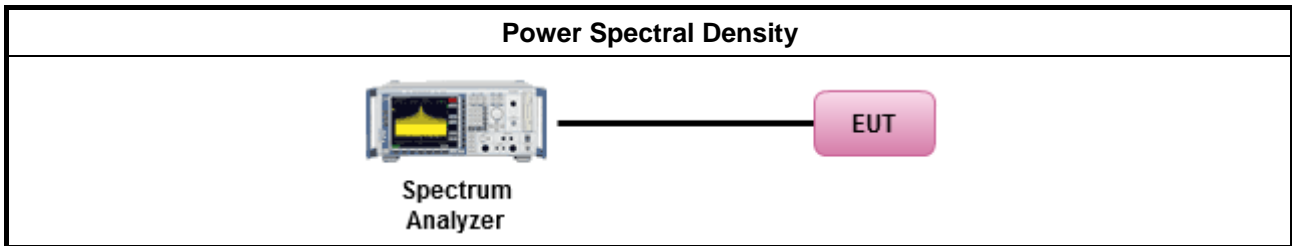

3.4.5 Test Result of Peak Power Spectral Density

Refer as Appendix D



3.5 Unwanted Emissions

3.5.1 Transmitter Unwanted Emissions Limit

Unwanted emissions below 1 GHz and restricted band emissions above 1GHz limit			
Frequency Range (MHz)	Field Strength (uV/m)	Field Strength (dBuV/m)	Measure Distance (m)
0.009~0.490	2400/F(kHz)	48.5 - 13.8	300
0.490~1.705	24000/F(kHz)	33.8 - 23	30
1.705~30.0	30	29	30
30~88	100	40	3
88~216	150	43.5	3
216~960	200	46	3
Above 960	500	54	3

Note 1: Test distance for frequencies at or above 30 MHz, measurements may be performed at a distance other than the limit distance provided they are not performed in the near field and the emissions to be measured can be detected by the measurement equipment. When performing measurements at a distance other than that specified, the results shall be extrapolated to the specified distance using an extrapolation factor of 20 dB/decade (inverse of linear distance for field-strength measurements, inverse of linear distance-squared for power-density measurements).

Note 2: Test distance for frequencies at below 30 MHz, measurements may be performed at a distance closer than the EUT limit distance; however, an attempt should be made to avoid making measurements in the near field. When performing measurements below 30 MHz at a closer distance than the limit distance, the results shall be extrapolated to the specified distance by either making measurements at a minimum of two or more distances on at least one radial to determine the proper extrapolation factor or by using the square of an inverse linear distance extrapolation factor (40 dB/decade). The test report shall specify the extrapolation method used to determine compliance of the EUT.

Note 3: Using the distance of 1m during the test for above 18 GHz, and the test value to correct for the distance factor at 3m.

Un-restricted band emissions above 1GHz Limit	
Operating Band	Limit
<input checked="" type="checkbox"/> 5.15 - 5.25 GHz	e.i.r.p. -27 dBm [68.2 dBuV/m@3m]
<input type="checkbox"/> 5.25 - 5.35 GHz	e.i.r.p. -27 dBm [68.2 dBuV/m@3m]
<input type="checkbox"/> 5.47 - 5.725 GHz	e.i.r.p. -27 dBm [68.2 dBuV/m@3m]
<input checked="" type="checkbox"/> 5.725 - 5.85 GHz	all emissions shall be limited to a level of -27 dBm/MHz at 75 MHz or more above or below the band edge increasing linearly to 10 dBm/MHz at 25 MHz above or below the band edge, and from 25 MHz above or below the band edge increasing linearly to a level of 15.6 dBm/MHz at 5 MHz above or below the band edge, and from 5 MHz above or below the band edge increasing linearly to a level of 27 dBm/MHz at the band edge.

Note 1: Measurements may be performed at a distance other than the limit distance provided they are not performed in the near field and the emissions to be measured can be detected by the measurement equipment. When performing measurements at a distance other than that specified, the results shall be extrapolated to the specified distance using an extrapolation factor of 20 dB/decade (inverse of



linear distance for field-strength measurements, inverse of linear distance-squared for power-density measurements).

3.5.2 Measuring Instruments

Refer a test equipment and calibration data table in this test report.

3.5.3 Test Procedures

Test Method	
	<ul style="list-style-type: none"> ▪ Measurements may be performed at a distance other than the limit distance provided they are not performed in the near field and the emissions to be measured can be detected by the measurement equipment. Measurements shall not be performed at a distance greater than 30 m for frequencies above 30 MHz, unless it can be further demonstrated that measurements at a distance of 30 m or less are impractical. When performing measurements at a distance other than that specified, the results shall be extrapolated to the specified distance using an extrapolation factor of 20 dB/decade (inverse of linear distance for field-strength measurements, inverse of linear distance-squared for power-density measurements).
	<ul style="list-style-type: none"> ▪ The average emission levels shall be measured in [duty cycle ≥ 98 or duty factor].
	<ul style="list-style-type: none"> ▪ For the transmitter unwanted emissions shall be measured using following options below: <ul style="list-style-type: none"> ▪ Refer as FCC KDB 789033, clause G)2) for unwanted emissions into non-restricted bands. ▪ Refer as FCC KDB 789033, clause G)1) for unwanted emissions into restricted bands. <ul style="list-style-type: none"> <input type="checkbox"/> Refer as FCC KDB 789033, G)6) Method AD (Trace Averaging). <input checked="" type="checkbox"/> Refer as FCC KDB 789033, G)6) Method VB (Reduced VBW). <input type="checkbox"/> Refer as ANSI C63.10, clause 11.12.2.5.3 (Reduced VBW). VBW ≥ 1/T, where T is pulse time. <input type="checkbox"/> Refer as ANSI C63.10, clause 7.5 average value of pulsed emissions. <input checked="" type="checkbox"/> Refer as FCC KDB 789033, clause G)5) measurement procedure peak limit. <input type="checkbox"/> Refer as ANSI C63.10, clause 4.1.4.2.2 measurement procedure peak limit.
	<ul style="list-style-type: none"> ▪ For radiated measurement. <ul style="list-style-type: none"> ▪ Refer as ANSI C63.10, clause 6.4 for radiated emissions below 30 MHz and test distance is 3m. ▪ Refer as ANSI C63.10, clause 6.5 for radiated emissions 30 MHz to 1 GHz and test distance is 3m. ▪ Refer as ANSI C63.10, clause 6.6 for radiated emissions above 1GHz.
	<ul style="list-style-type: none"> ▪ The any unwanted emissions level shall not exceed the fundamental emission level.
	<ul style="list-style-type: none"> ▪ All amplitude of spurious emissions that are attenuated by more than 20 dB below the permissible value has no need to be reported.

3.5.4 Test Setup

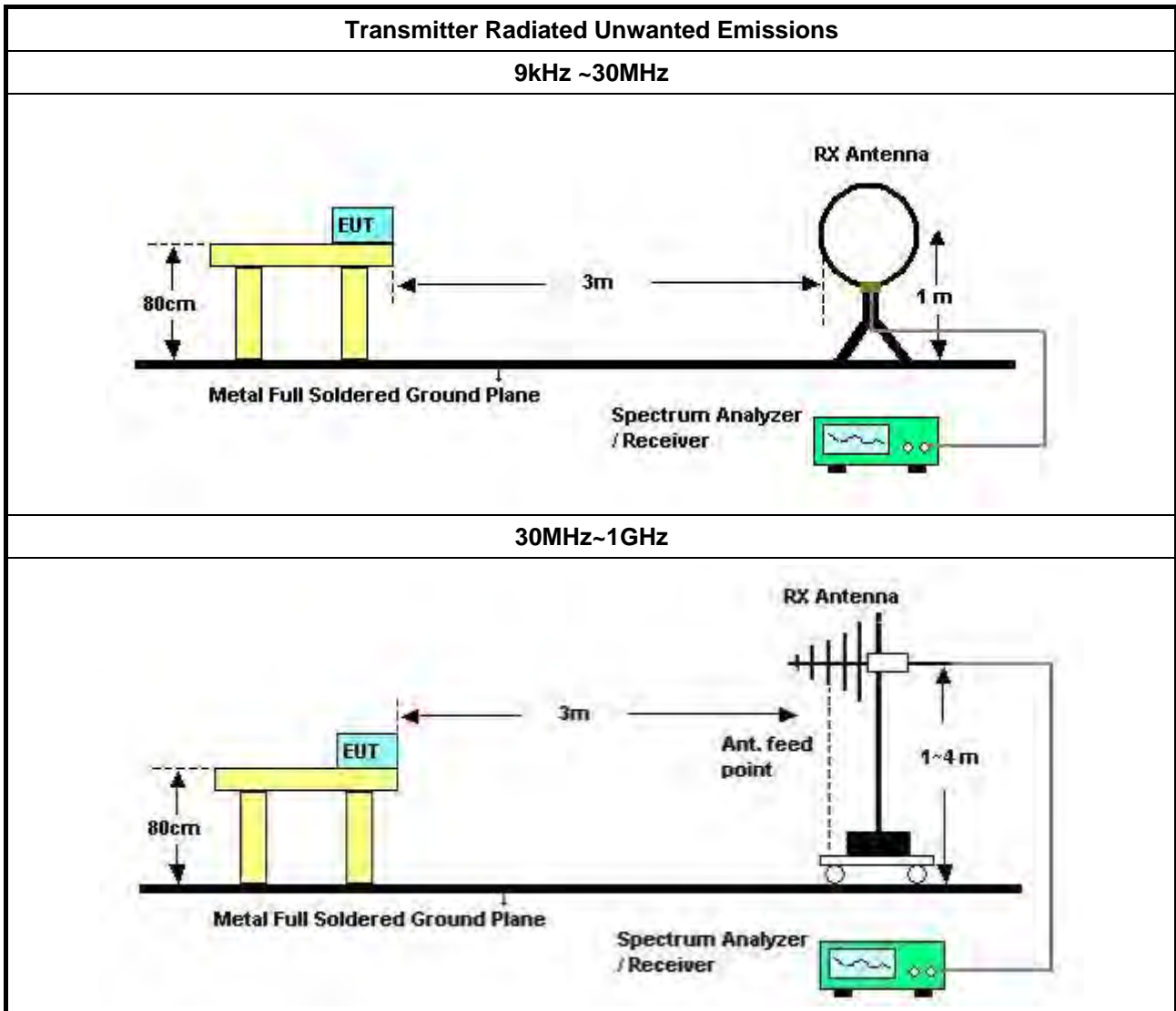

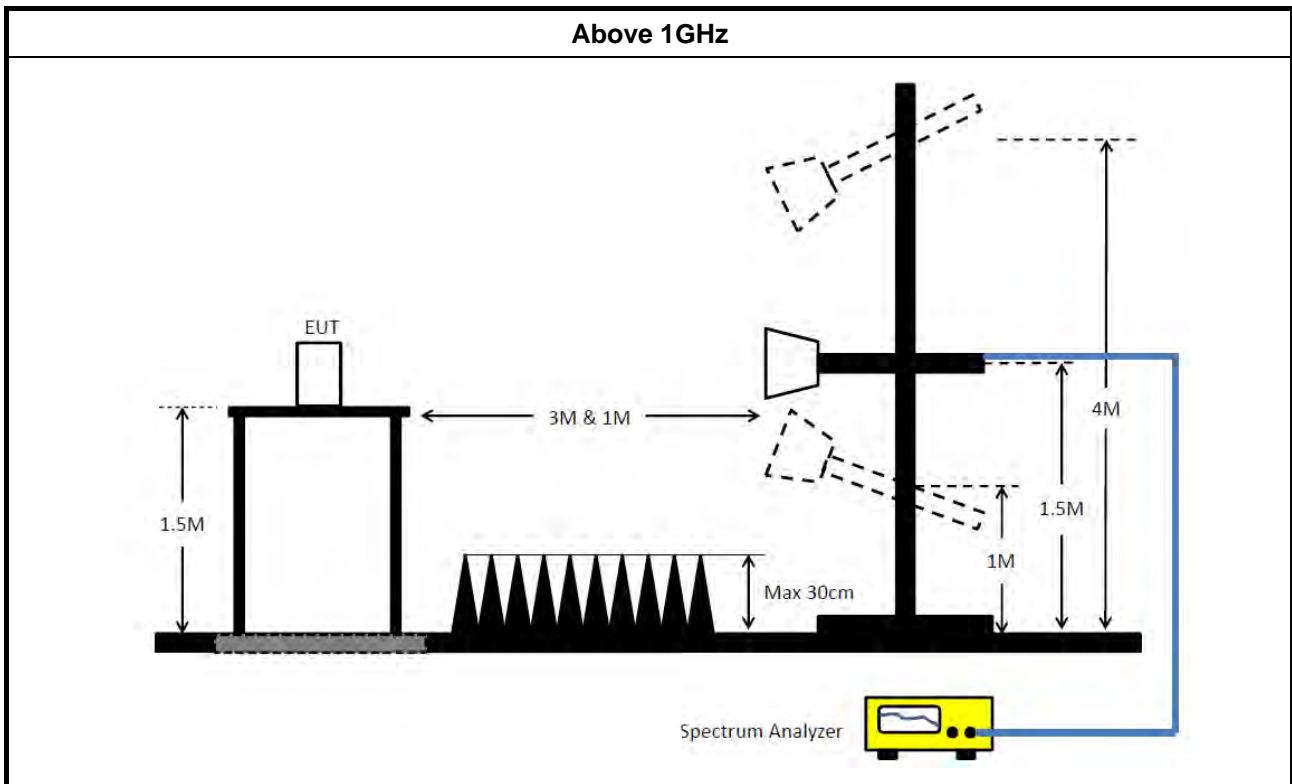

3.5.5 Transmitter Unwanted Emissions (Below 30MHz)

All amplitude of spurious emissions that are attenuated by more than 20 dB below the permissible value has no need to be reported.

The radiated emissions were investigated from 9 kHz or the lowest frequency generated within the device, up to the 10 harmonic or 40 GHz, whichever is appropriate.

3.5.6 Test Result of Transmitter Unwanted Emissions

Refer as Appendix E



4 Test Equipment and Calibration Data

Instrument	Manufacturer	Model No.	Serial No.	Characteristics	Calibration Date	Calibration Due Date	Remark
LISN	Schwarzbeck	NSLK 8127	8127650	9kHz ~ 30MHz	Nov. 21, 2018	Nov. 20, 2019	Conduction (CO02-CB)
LISN	Schwarzbeck	NSLK 8127	8127478	9kHz ~ 30MHz	Nov. 05, 2018	Nov. 04, 2019	Conduction (CO02-CB)
EMI Receiver	Agilent	N9038A	MY52260140	9kHz ~ 8.4GHz	Jan. 16, 2019	Jan. 15, 2020	Conduction (CO02-CB)
COND Cable	Woken	Cable	2	0.15MHz ~ 30MHz	Nov. 06, 2018	Nov. 05, 2019	Conduction (CO02-CB)
Software	Audix	E3	6.120210n	-	N.C.R.	N.C.R.	Conduction (CO02-CB)
BILOG ANTENNA with 6dB Attenuator	TESEQ & EMCI	CBL6112D & N-6-06	37880 & AT-N0609	20MHz ~ 2GHz	Aug. 27, 2018	Aug. 26, 2019	Radiation (03CH01-CB)
Horn Antenna	EMCO	3115	00075790	750MHz ~ 18GHz	Nov. 13, 2018	Nov. 12, 2019	Radiation (03CH01-CB)
Horn Antenna	Schwarzbeck	BBHA 9170	BBHA9170252	15GHz ~ 40GHz	Jun. 28, 2018	Jun. 27, 2019	Radiation (03CH01-CB)
Pre-Amplifier	EMCI	EMC330N	980332	20MHz ~ 3GHz	May 02, 2018	May 01, 2019	Radiation (03CH01-CB)
Pre-Amplifier	Agilent	8449B	3008A02310	1GHz ~ 26.5GHz	Jan. 08, 2019	Jan. 07, 2020	Radiation (03CH01-CB)
Pre-Amplifier	MITEQ	TTA1840-35-HG	1864479	18GHz ~ 40GHz	Jul. 04, 2018	Jul. 03, 2019	Radiation (03CH01-CB)
Spectrum Analyzer	R&S	FSP40	100056	9kHz ~ 40GHz	Jan. 31, 2019	Jan. 30, 2020	Radiation (03CH01-CB)
EMI Test Receiver	R&S	ESCS	100359	9kHz ~ 2.75GHz	Jul. 03, 2018	Jul. 02, 2019	Radiation (03CH01-CB)
RF Cable-low	Woken	Low Cable-16+17	N/A	30 MHz ~ 1 GHz	Oct. 08, 2018	Oct. 07, 2019	Radiation (03CH01-CB)
RF Cable-high	Woken	High Cable-16	N/A	1 GHz ~ 18 GHz	Oct. 08, 2018	Oct. 07, 2019	Radiation (03CH01-CB)
RF Cable-high	Woken	High Cable-16+17	N/A	1 GHz ~ 18 GHz	Oct. 08, 2018	Oct. 07, 2019	Radiation (03CH01-CB)
RF Cable-high	Woken	High Cable-40G#1	N/A	18GHz ~ 40 GHz	Jul. 27, 2018	Jul. 26, 2019	Radiation (03CH01-CB)
RF Cable-high	Woken	High Cable-40G#2	N/A	18GHz ~ 40 GHz	Jul. 27, 2018	Jul. 26, 2019	Radiation (03CH01-CB)
Spectrum analyzer	R&S	FSV40	100979	9kHz~40GHz	Feb. 25, 2019	Feb. 24, 2020	Conducted (TH01-CB)
Temp. and Humidity Chamber	Ten Billion	TTH-D3SP	TBN-931011	-30~100 degree	Jun. 01, 2018	May 31, 2019	Conducted (TH01-CB)
RF Cable-high	Woken	RG402	High Cable-06	1 GHz ~ 26.5 GHz	Oct. 08, 2018	Oct. 07, 2019	Conducted (TH01-CB)
RF Cable-high	Woken	RG402	High Cable-07	1 GHz ~ 26.5 GHz	Oct. 08, 2018	Oct. 07, 2019	Conducted (TH01-CB)



Instrument	Manufacturer	Model No.	Serial No.	Characteristics	Calibration Date	Calibration Due Date	Remark
RF Cable-high	Woken	RG402	High Cable-08	1 GHz –26.5 GHz	Oct. 08, 2018	Oct. 07, 2019	Conducted (TH01-CB)
RF Cable-high	Woken	RG402	High Cable-09	1 GHz –26.5 GHz	Oct. 08, 2018	Oct. 07, 2019	Conducted (TH01-CB)
RF Cable-high	Woken	RG402	High Cable-10	1 GHz –26.5 GHz	Oct. 08, 2018	Oct. 07, 2019	Conducted (TH01-CB)
RF Cable-high	Woken	RG402	High Cable-28	1 GHz –26.5 GHz	Nov. 19, 2018	Nov. 18, 2019	Conducted (TH01-CB)
Power Sensor	Agilent	U2021XA	MY53410001	50MHz~18GHz	Nov. 05, 2018	Nov. 04, 2019	Conducted (TH01-CB)

Note: Calibration Interval of instruments listed above is one year.

N.C.R. means Non-Calibration required.



AC Power-line Conducted Emissions Result

Appendix A

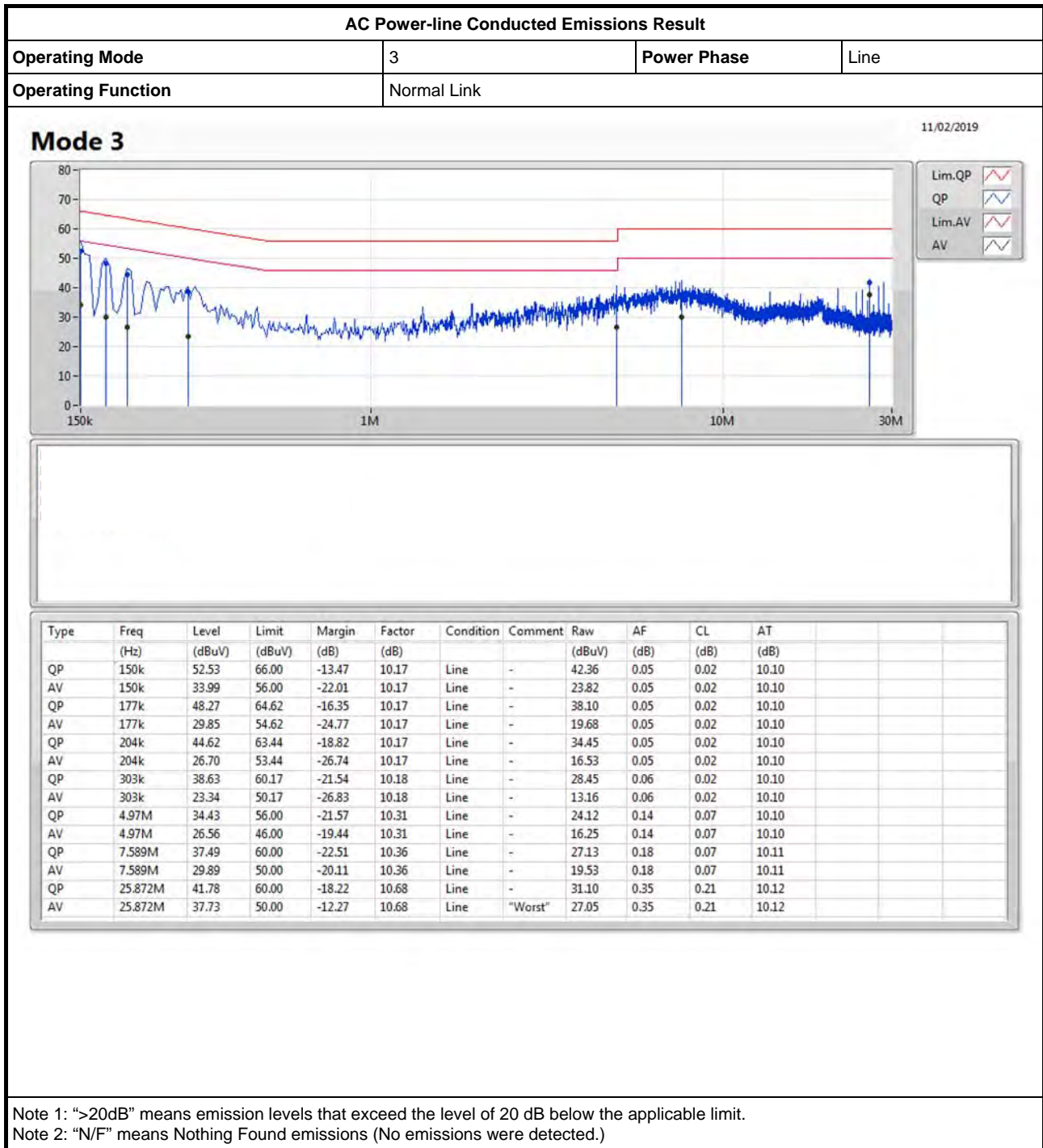



AC Power-line Conducted Emissions Result

Appendix A

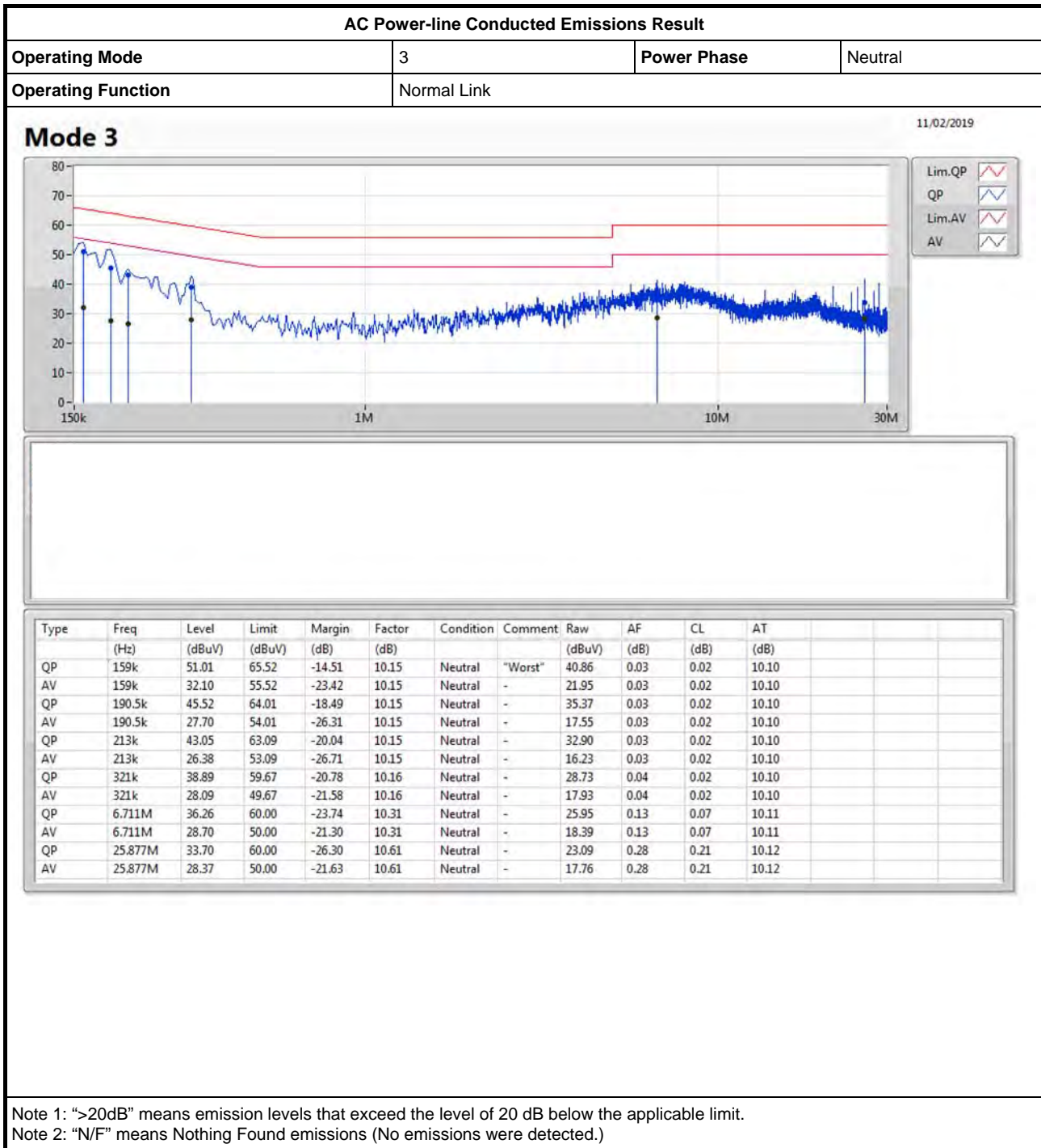



**For Radio 2
Summary**

Mode	Max-N dB (Hz)	Max-OBW (Hz)	ITU-Code	Min-N dB (Hz)	Min-OBW (Hz)
5.15-5.25GHz	-	-	-	-	-
802.11a_Nss1,(6Mbps)_4TX	20.475M	16.442M	16M4D1D	19.95M	16.417M
802.11ac VHT20_Nss1,(MCS0)_4TX	21.35M	17.641M	17M6D1D	20.775M	17.591M
802.11ac VHT40_Nss1,(MCS0)_4TX	40.4M	36.182M	36M2D1D	39.45M	36.132M
802.11ac VHT80_Nss1,(MCS0)_4TX	80.4M	75.962M	76M0D1D	80.2M	75.762M
5.725-5.85GHz	-	-	-	-	-
802.11a_Nss1,(6Mbps)_4TX	16.325M	17.066M	17M1D1D	16.275M	16.517M
802.11ac VHT20_Nss1,(MCS0)_4TX	17.675M	17.941M	17M9D1D	16.825M	17.641M
802.11ac VHT40_Nss1,(MCS0)_4TX	36.3M	36.632M	36M6D1D	35.5M	36.282M
802.11ac VHT80_Nss1,(MCS0)_4TX	75.9M	75.862M	75M9D1D	75M	75.662M

Max-N dB = Maximum 6dB down bandwidth for 5.725-5.85GHz band / Maximum 26dB down bandwidth for other band;

Max-OBW = Maximum 99% occupied bandwidth;

Min-N dB = Minimum 6dB down bandwidth for 5.725-5.85GHz band / Maximum 26dB down bandwidth for other band;

Min-OBW = Minimum 99% occupied bandwidth;



EBW Result

Appendix B.1

Result

Mode	Result	Limit (Hz)	Port 1-N dB (Hz)	Port 1-OBW (Hz)	Port 2-N dB (Hz)	Port 2-OBW (Hz)	Port 3-N dB (Hz)	Port 3-OBW (Hz)	Port 4-N dB (Hz)	Port 4-OBW (Hz)
802.11a_Nss1,(6Mbps)_4TX	-	-	-	-	-	-	-	-	-	-
5180MHz	Pass	Inf	20.425M	16.417M	20.475M	16.417M	20.15M	16.417M	20.3M	16.417M
5200MHz	Pass	Inf	20.35M	16.417M	20.375M	16.442M	19.975M	16.417M	19.95M	16.417M
5240MHz	Pass	Inf	20.4M	16.442M	19.975M	16.417M	20.175M	16.442M	20.2M	16.417M
5745MHz	Pass	500k	16.325M	16.567M	16.325M	16.617M	16.3M	16.517M	16.325M	16.567M
5785MHz	Pass	500k	16.275M	16.617M	16.275M	16.792M	16.275M	16.667M	16.325M	16.742M
5825MHz	Pass	500k	16.275M	17.066M	16.3M	16.742M	16.325M	16.617M	16.275M	16.867M
802.11ac_VHT20_Nss1,(MCS0)_4TX	-	-	-	-	-	-	-	-	-	-
5180MHz	Pass	Inf	20.8M	17.616M	21.1M	17.641M	20.975M	17.616M	21.075M	17.641M
5200MHz	Pass	Inf	20.875M	17.641M	21.05M	17.641M	21.35M	17.616M	20.95M	17.616M
5240MHz	Pass	Inf	21.075M	17.616M	21.1M	17.641M	20.775M	17.591M	20.775M	17.641M
5745MHz	Pass	500k	17.525M	17.666M	17.525M	17.691M	17.575M	17.641M	17.15M	17.666M
5785MHz	Pass	500k	17.525M	17.766M	17.55M	17.866M	17.55M	17.741M	17.55M	17.816M
5825MHz	Pass	500k	17.675M	17.941M	16.825M	17.841M	17.55M	17.766M	17.55M	17.891M
802.11ac_VHT40_Nss1,(MCS0)_4TX	-	-	-	-	-	-	-	-	-	-
5190MHz	Pass	Inf	40.4M	36.182M	40.2M	36.132M	39.95M	36.132M	39.45M	36.132M
5230MHz	Pass	Inf	40.35M	36.182M	40.15M	36.182M	40.1M	36.182M	39.45M	36.182M
5755MHz	Pass	500k	35.65M	36.332M	35.9M	36.432M	35.85M	36.282M	35.9M	36.332M
5795MHz	Pass	500k	35.5M	36.432M	36.3M	36.632M	36.25M	36.382M	36.3M	36.582M
802.11ac_VHT80_Nss1,(MCS0)_4TX	-	-	-	-	-	-	-	-	-	-
5210MHz	Pass	Inf	80.4M	75.762M	80.2M	75.762M	80.2M	75.862M	80.3M	75.962M
5775MHz	Pass	500k	75.7M	75.862M	75M	75.762M	75.9M	75.662M	75.4M	75.862M

Port X-N dB = Port X 6dB down bandwidth for 5.725-5.85GHz band / 26dB down bandwidth for other band

Port X-OBW = Port X 99% occupied bandwidth;

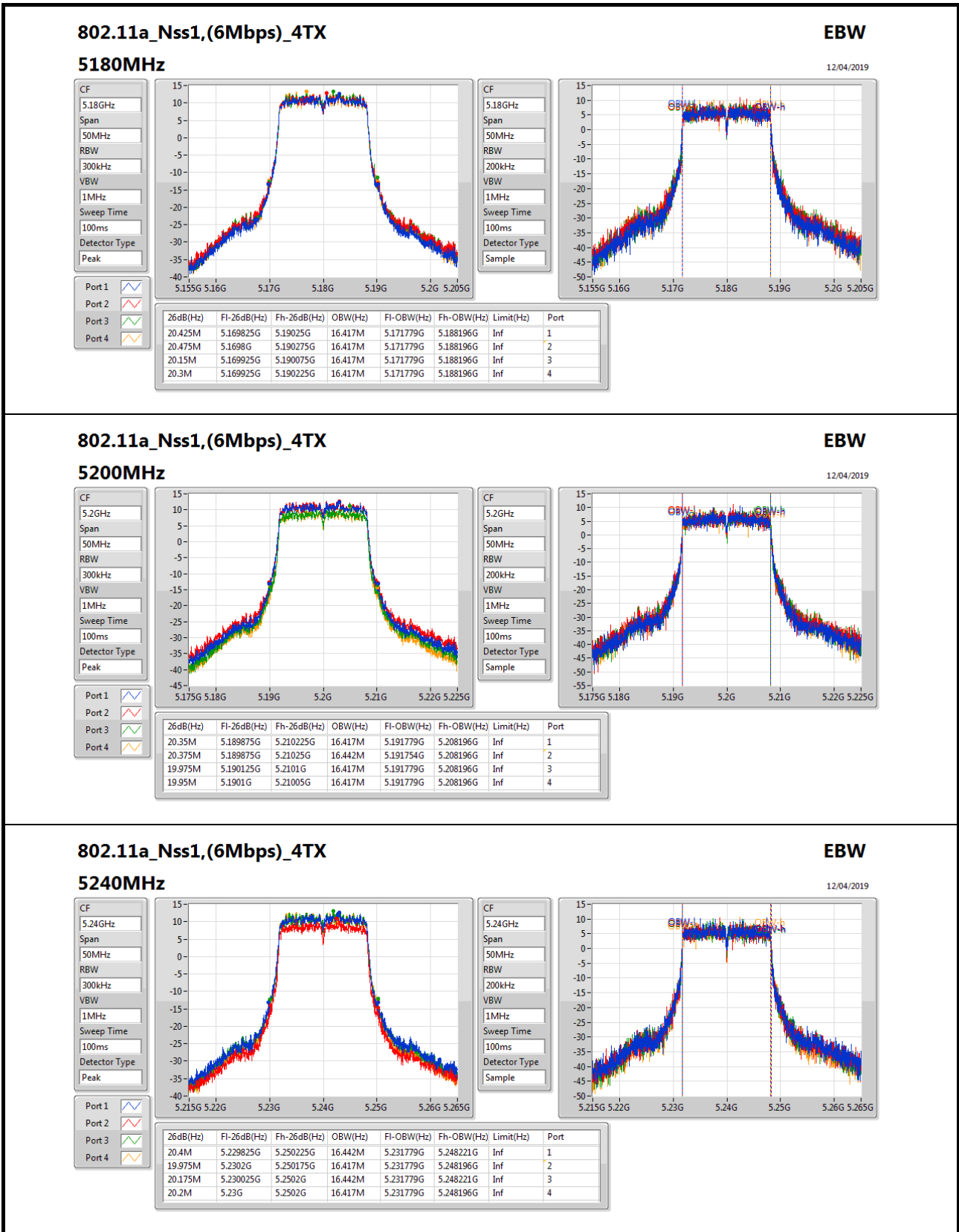

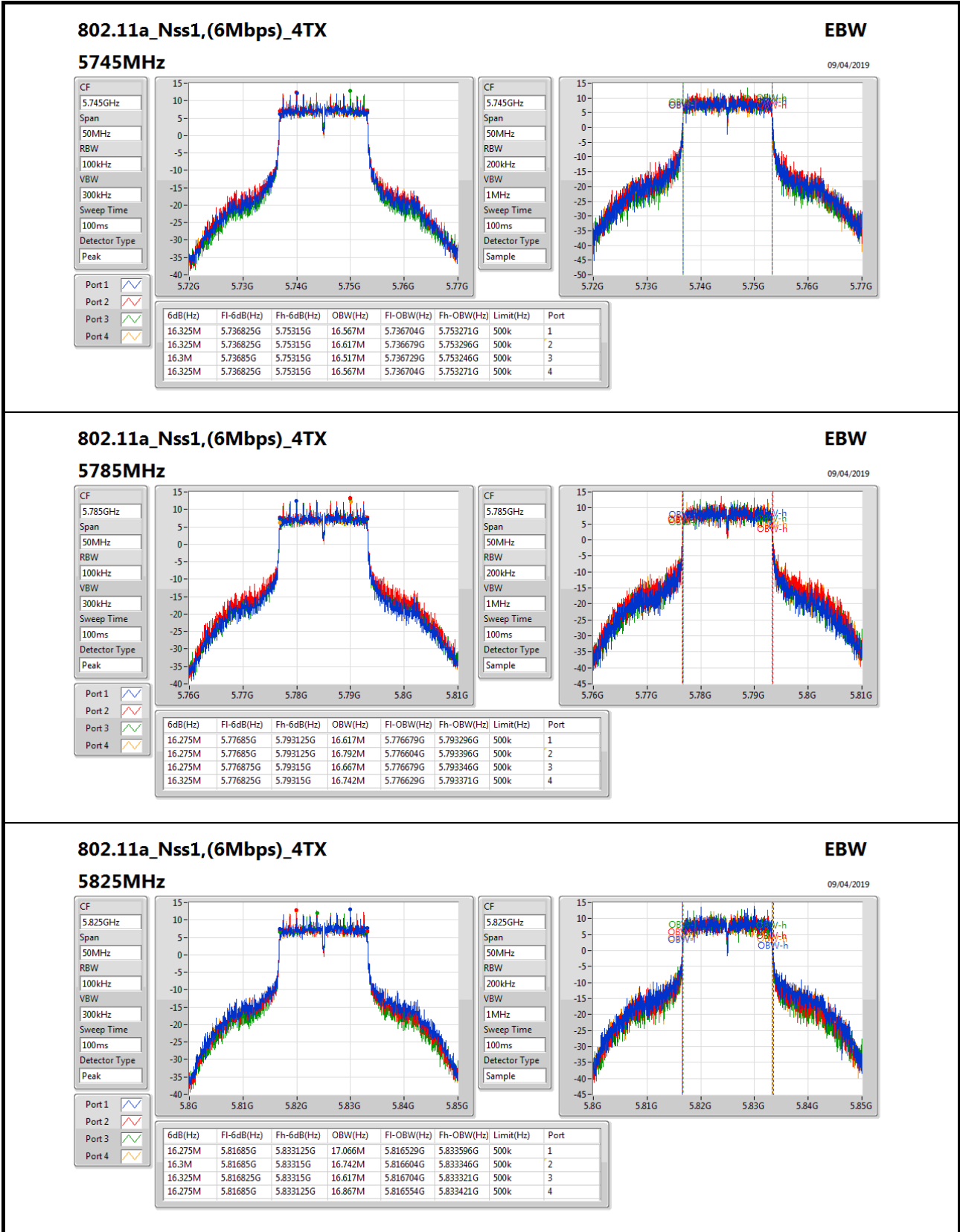

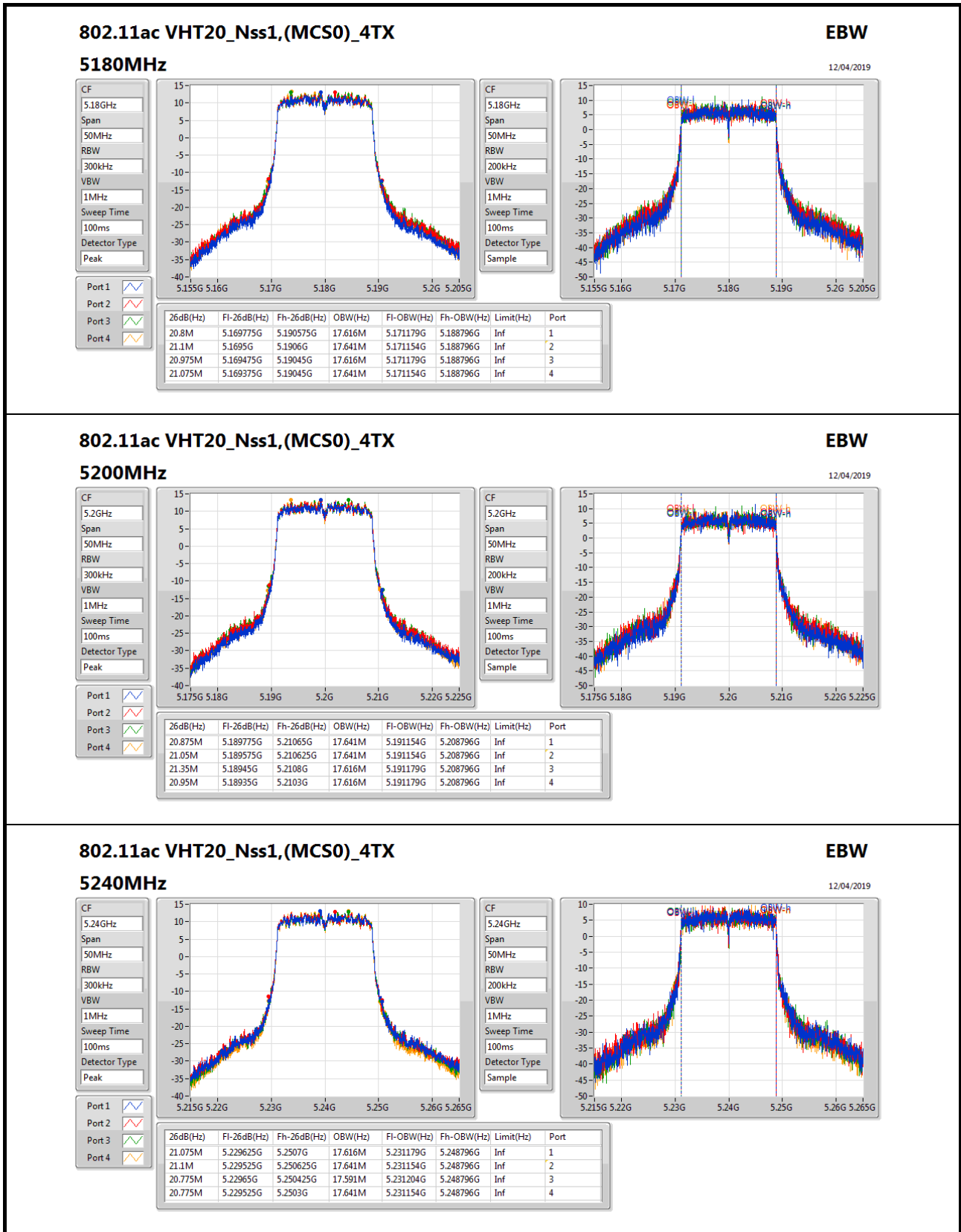

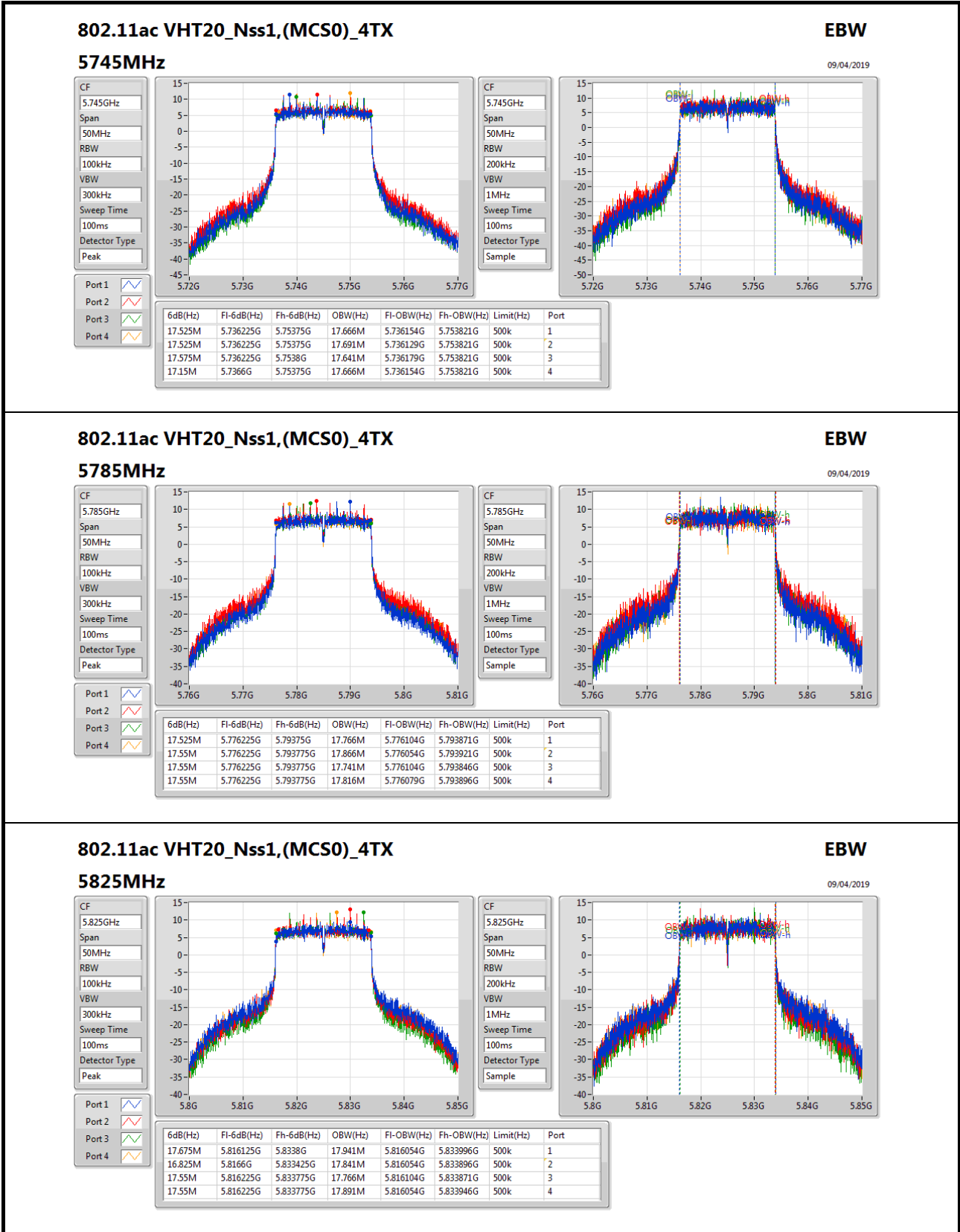

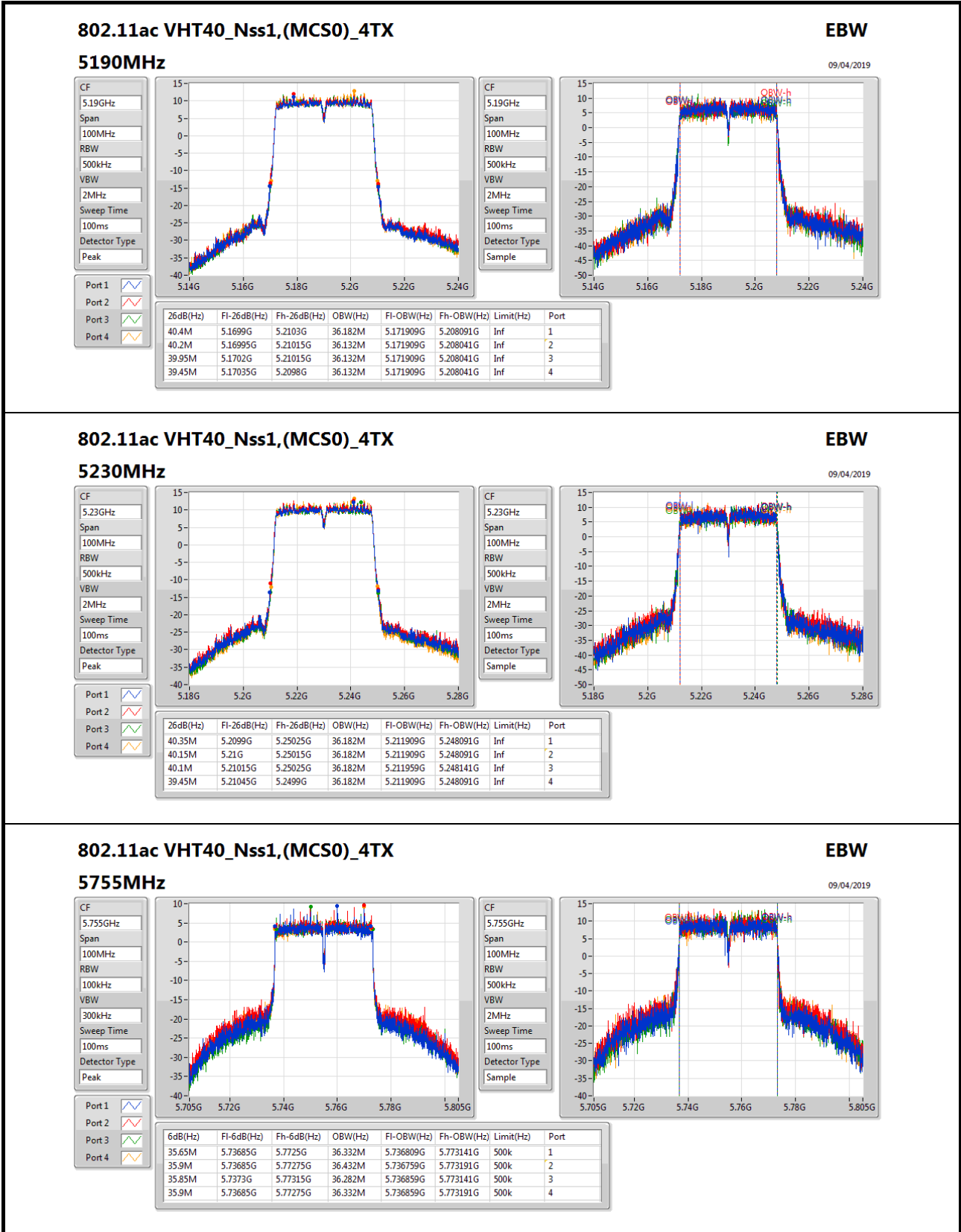

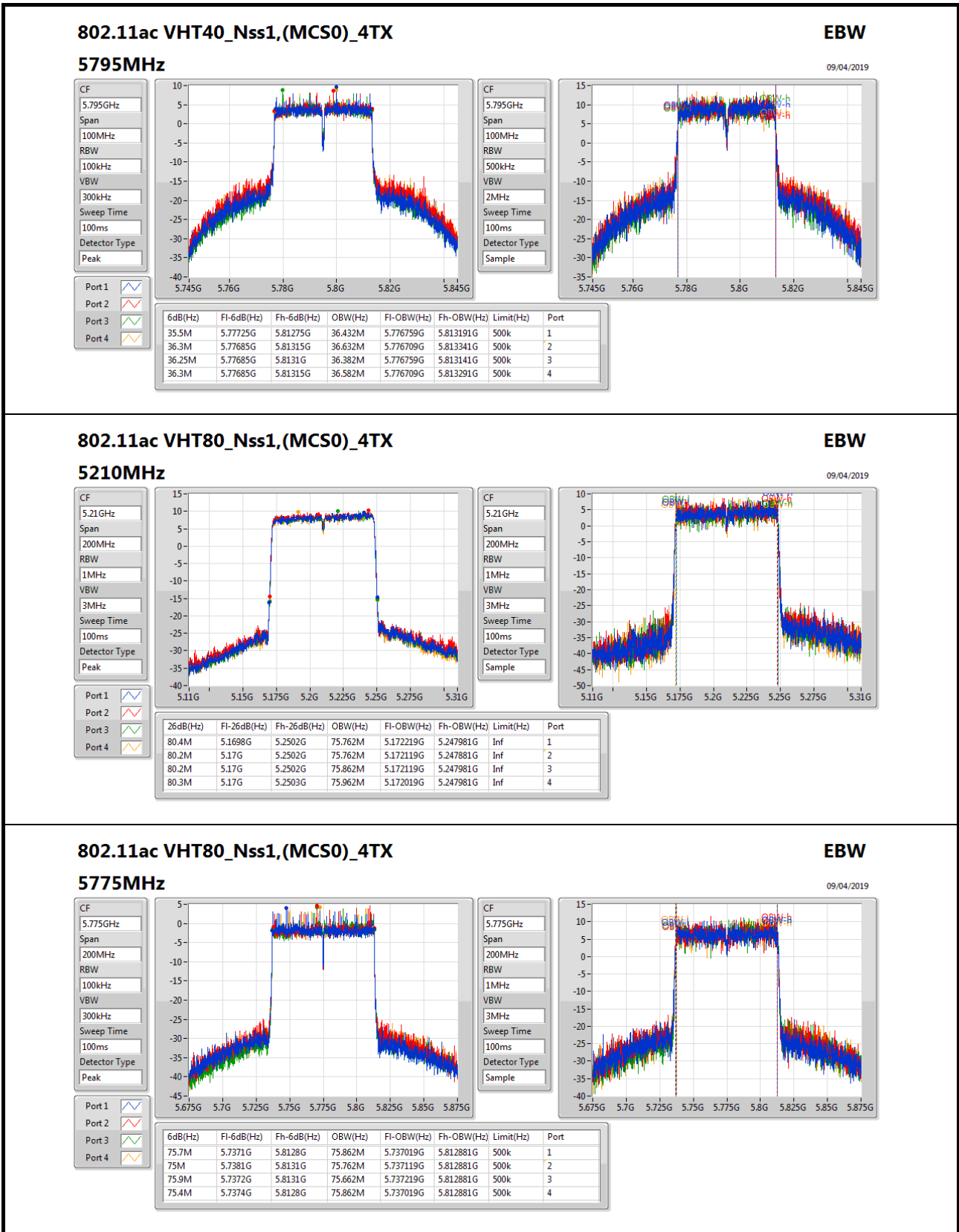



**For Radio 3
Summary**

Mode	Max-N dB (Hz)	Max-OBW (Hz)	ITU-Code	Min-N dB (Hz)	Min-OBW (Hz)
5.15-5.25GHz	-	-	-	-	-
802.11a_Nss1,(6Mbps)_2TX	44.025M	26.437M	26M4D1D	25M	16.592M
802.11ac VHT20_Nss1,(MCS0)_2TX	49.55M	28.861M	28M9D1D	24.95M	17.741M
802.11ac VHT40_Nss1,(MCS0)_2TX	82.45M	37.331M	37M3D1D	45.25M	36.282M
802.11ac VHT80_Nss1,(MCS0)_2TX	90.4M	75.962M	76M0D1D	87.9M	75.862M
5.725-5.85GHz	-	-	-	-	-
802.11a_Nss1,(6Mbps)_2TX	16.325M	33.108M	33M1D1D	15.675M	32.234M
802.11ac VHT20_Nss1,(MCS0)_2TX	17.525M	34.758M	34M8D1D	16.525M	33.858M
802.11ac VHT40_Nss1,(MCS0)_2TX	36.3M	67.416M	67M4D1D	35.4M	58.121M
802.11ac VHT80_Nss1,(MCS0)_2TX	71.6M	88.656M	88M7D1D	66.3M	78.361M

Max-N dB = Maximum 6dB down bandwidth for 5.725-5.85GHz band / Maximum 26dB down bandwidth for other band;

Max-OBW = Maximum 99% occupied bandwidth;

Min-N dB = Minimum 6dB down bandwidth for 5.725-5.85GHz band / Maximum 26dB down bandwidth for other band;

Min-OBW = Minimum 99% occupied bandwidth;



EBW Result

Appendix B.2

Result

Mode	Result	Limit (Hz)	Port 1-N dB (Hz)	Port 1-OBW (Hz)	Port 2-N dB (Hz)	Port 2-OBW (Hz)
802.11a_Nss1,(6Mbps)_2TX	-	-	-	-	-	-
5180MHz	Pass	Inf	25M	16.592M	31.25M	16.667M
5200MHz	Pass	Inf	44.025M	23.538M	42.55M	26.437M
5240MHz	Pass	Inf	38.025M	17.516M	38.975M	19.19M
5745MHz	Pass	500k	16.275M	32.534M	16.3M	32.834M
5785MHz	Pass	500k	16.025M	32.234M	16.325M	32.909M
5825MHz	Pass	500k	16.275M	33.108M	15.675M	33.033M
802.11ac VHT20_Nss1,(MCS0)_2TX	-	-	-	-	-	-
5180MHz	Pass	Inf	24.95M	17.741M	28.6M	17.841M
5200MHz	Pass	Inf	49.4M	26.212M	49.55M	28.861M
5240MHz	Pass	Inf	43.05M	18.191M	43.725M	19.44M
5745MHz	Pass	500k	17.525M	34.583M	17.525M	34.433M
5785MHz	Pass	500k	17.525M	33.858M	16.525M	34.483M
5825MHz	Pass	500k	16.875M	34.558M	17.5M	34.758M
802.11ac VHT40_Nss1,(MCS0)_2TX	-	-	-	-	-	-
5190MHz	Pass	Inf	46M	36.282M	45.25M	36.282M
5230MHz	Pass	Inf	81.95M	36.982M	82.45M	37.331M
5755MHz	Pass	500k	35.4M	59.12M	35.65M	58.121M
5795MHz	Pass	500k	36M	67.416M	36.3M	67.266M
802.11ac VHT80_Nss1,(MCS0)_2TX	-	-	-	-	-	-
5210MHz	Pass	Inf	90.4M	75.862M	87.9M	75.962M
5775MHz	Pass	500k	66.3M	78.361M	71.6M	88.656M

Port X-N dB = Port X 6dB down bandwidth for 5.725-5.85GHz band / 26dB down bandwidth for other band
 Port X-OBW = Port X 99% occupied bandwidth;

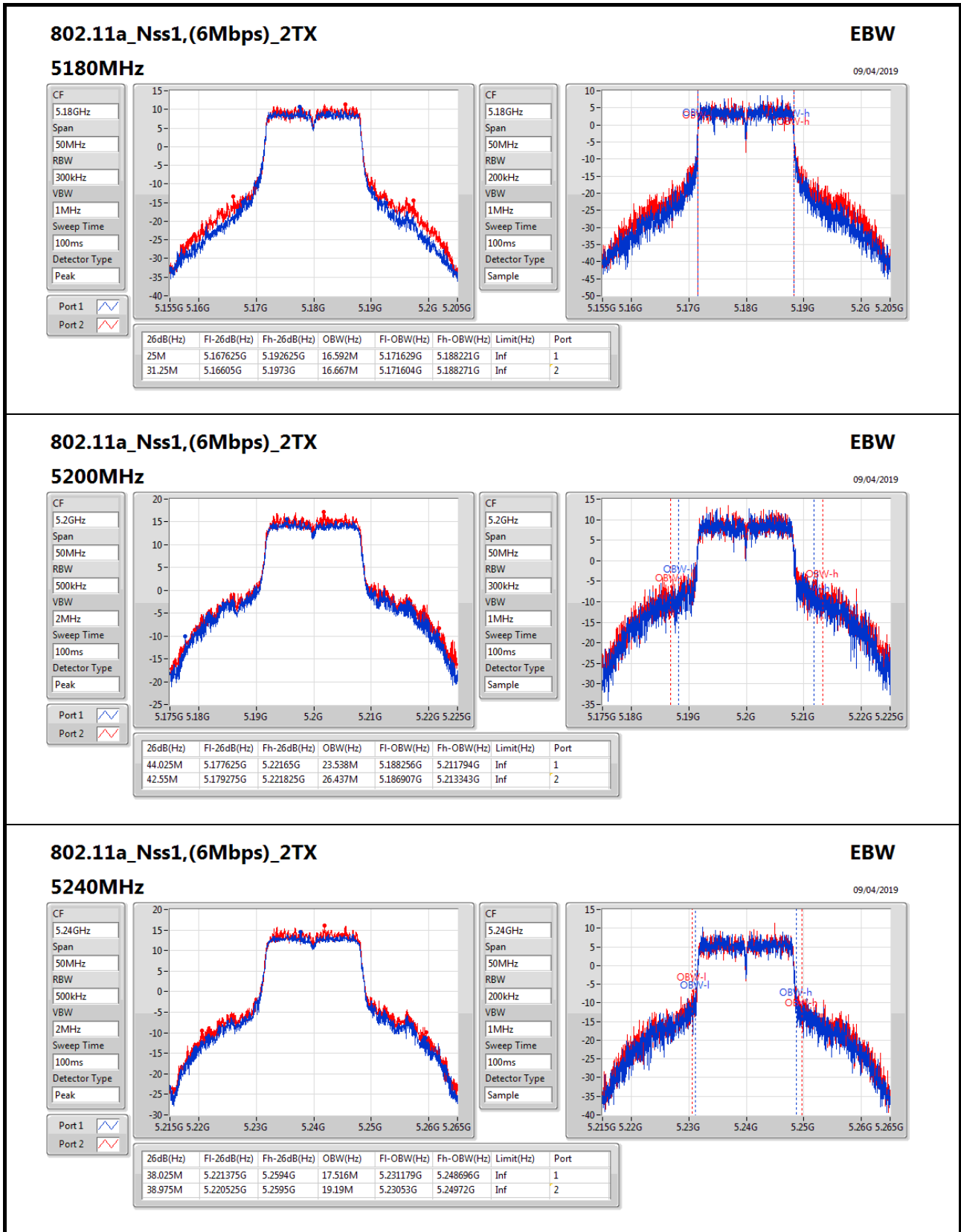

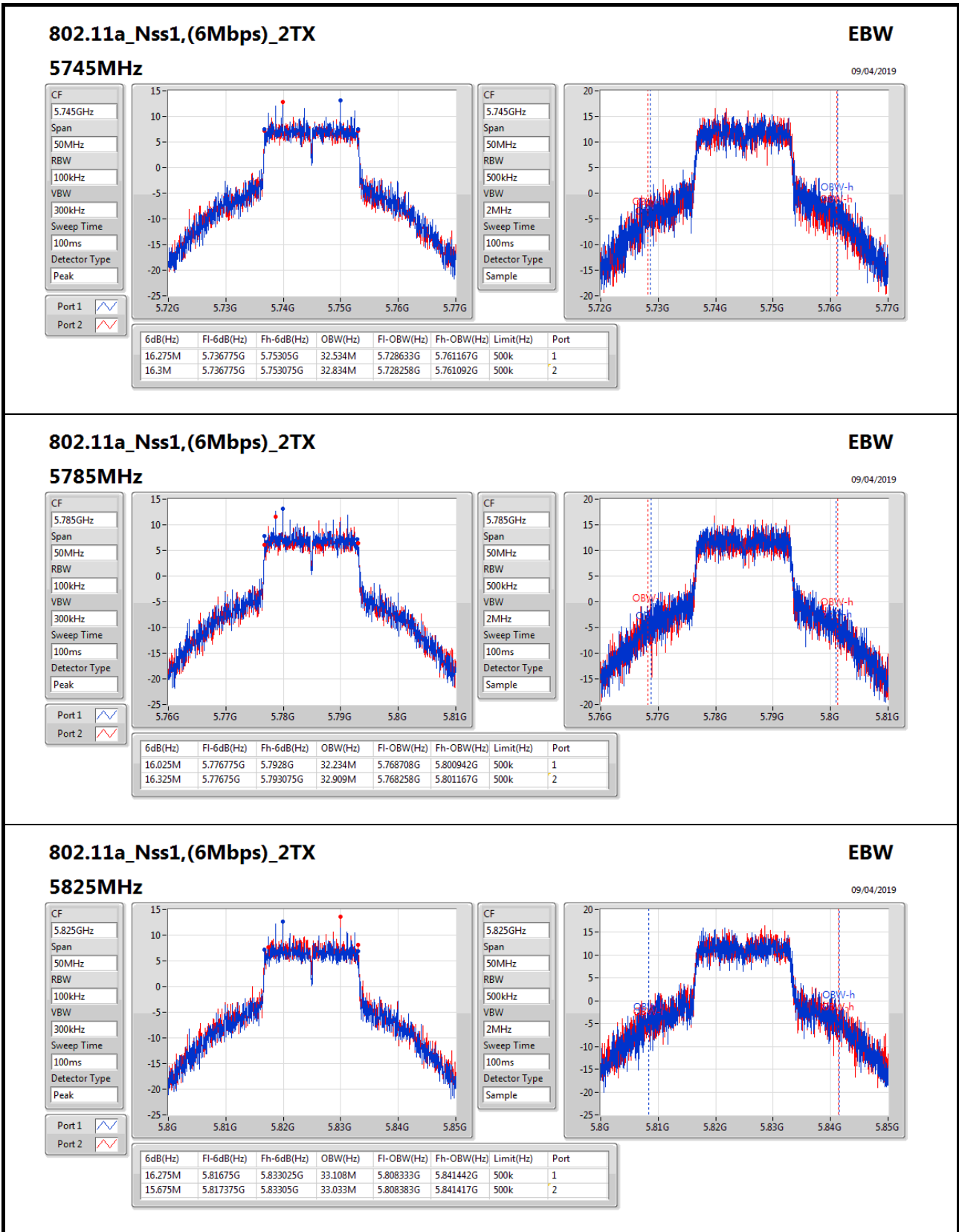
802.11a_Nss1,(6Mbps)_2TX
EBW

CF: 5.825GHz

Span: 50MHz

RBW: 100kHz

VBW: 300kHz

Sweep Time: 100ms

Detector Type: Peak

Port 1:

Port 2:

CF: 5.825GHz

Span: 50MHz

RBW: 500kHz

VBW: 2MHz

Sweep Time: 100ms

Detector Type: Sample

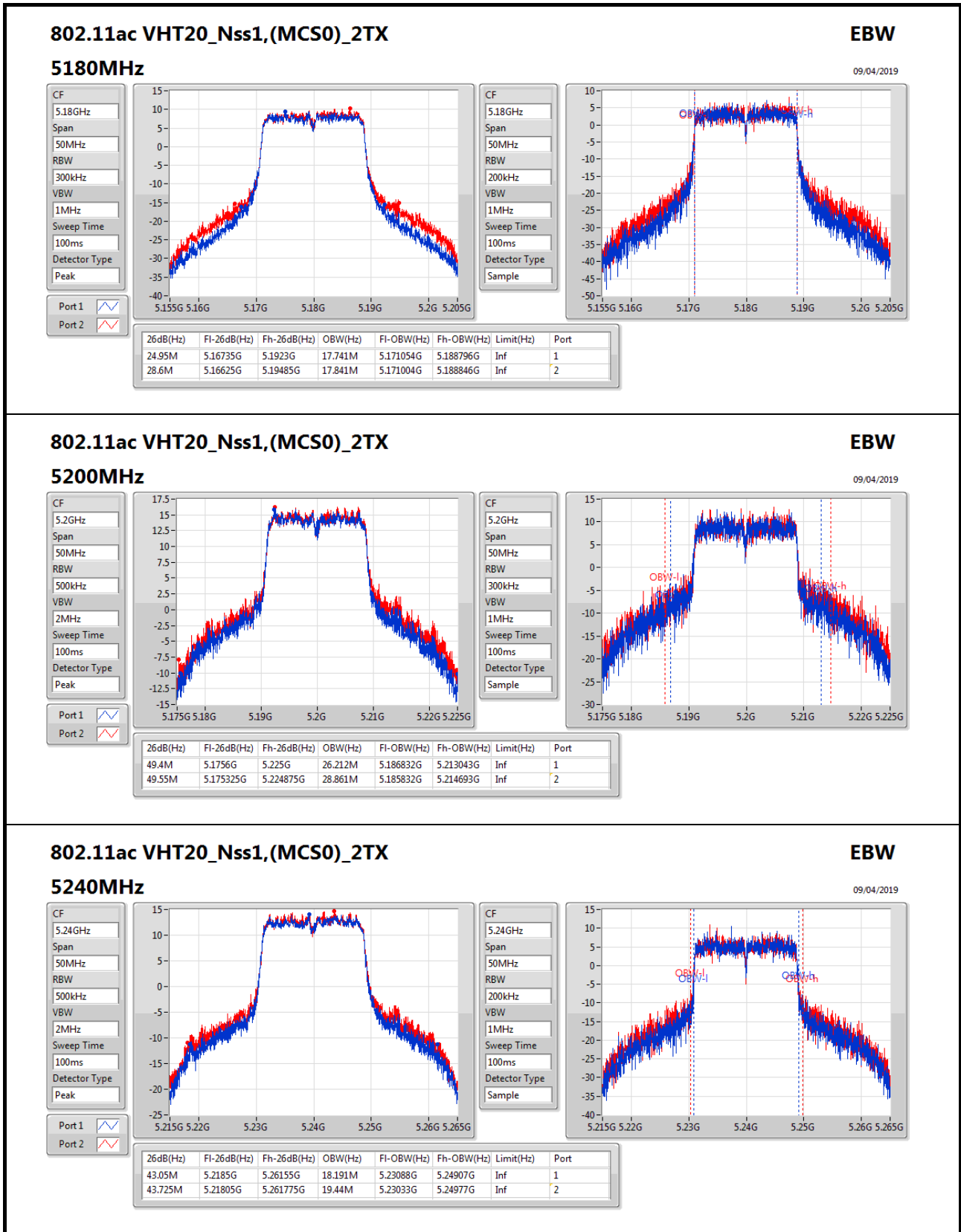

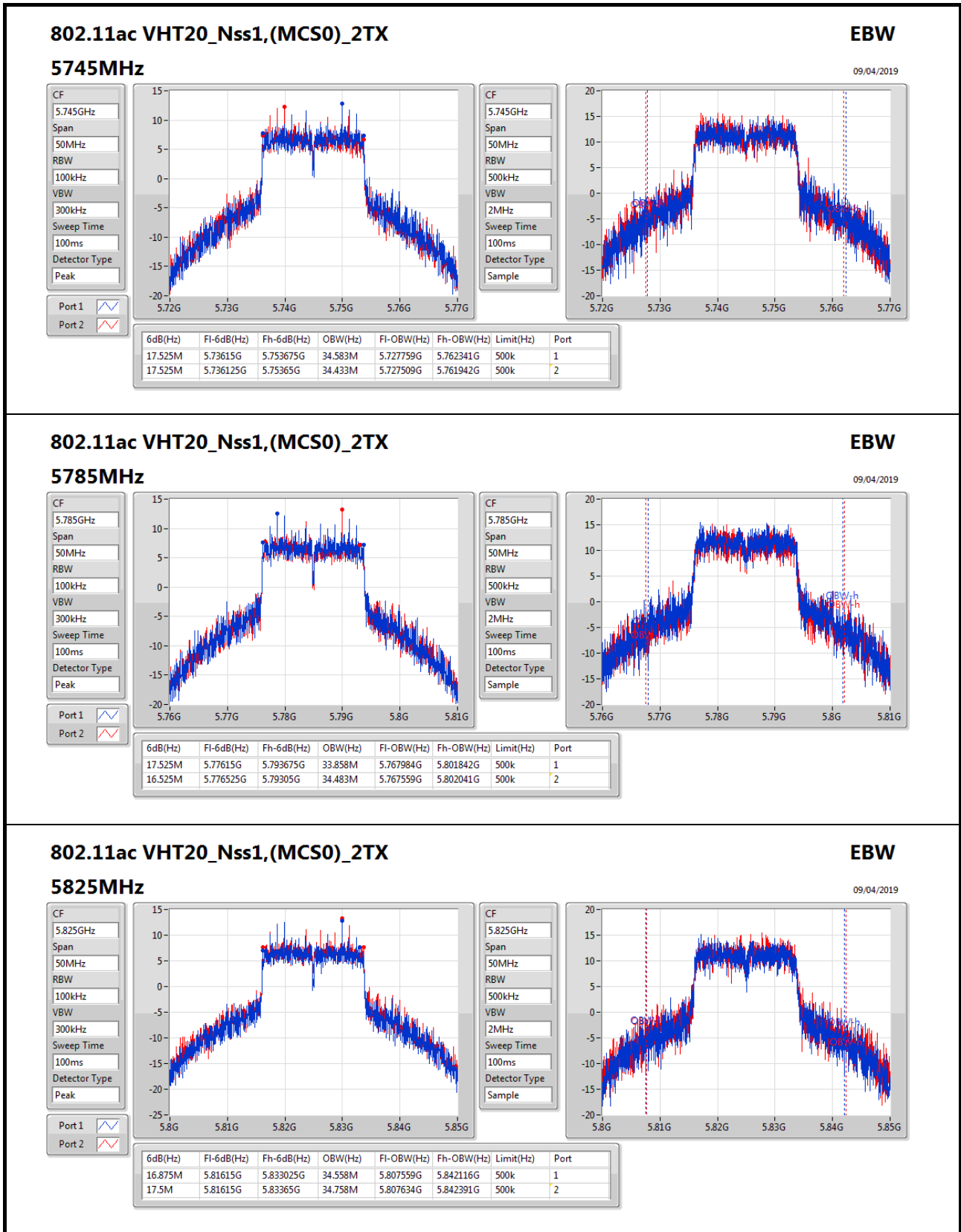
802.11ac VHT20_Nss1,(MCS0)_2TX
EBW

5825MHz

09/04/2019

CF: 5.825GHz
Span: 50MHz
RBW: 100kHz
VBW: 300kHz
Sweep Time: 100ms
Detector Type: Peak

Port 1:

Port 2:

CF: 5.825GHz
Span: 50MHz
RBW: 500kHz
VBW: 2MHz
Sweep Time: 100ms
Detector Type: Sample

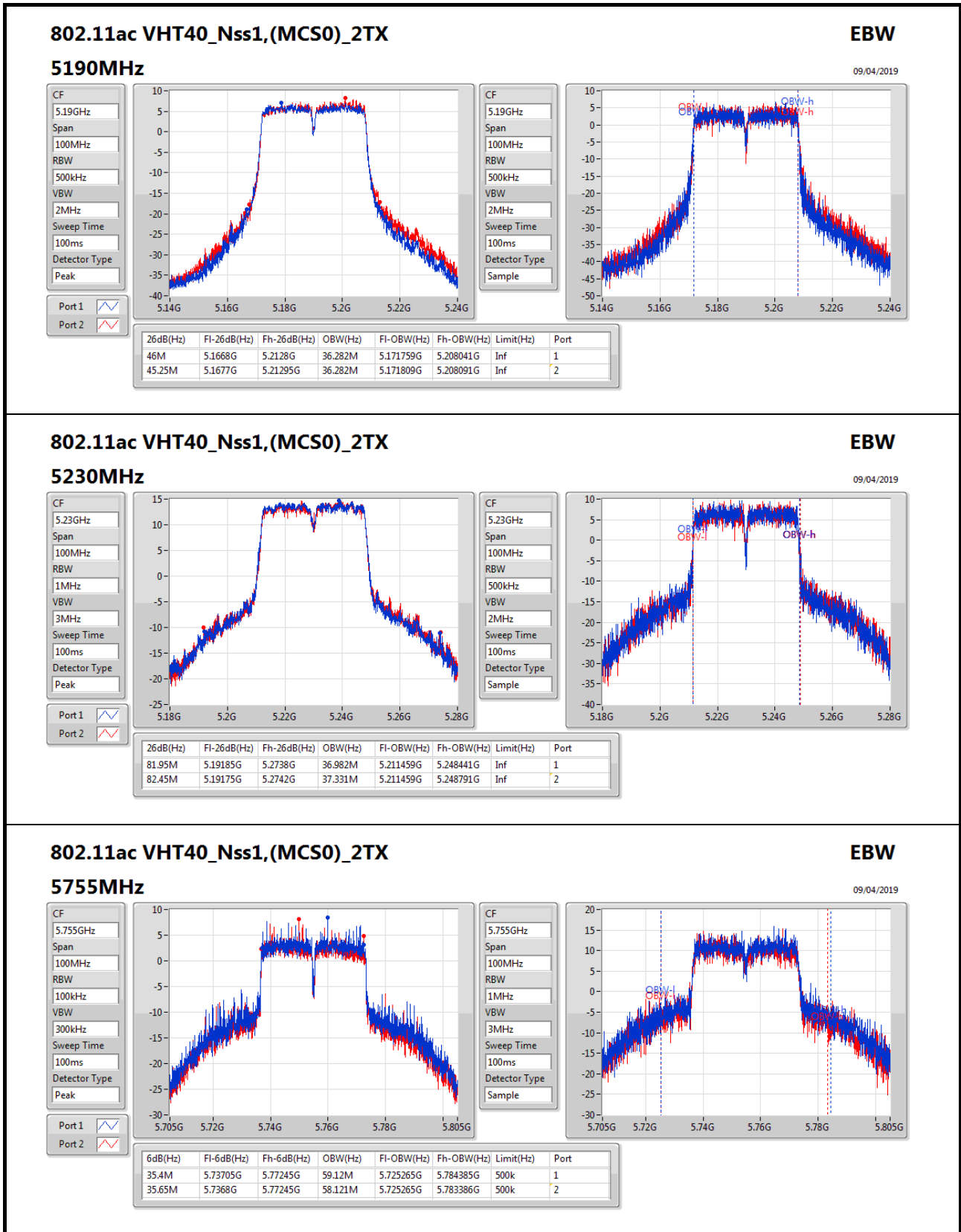

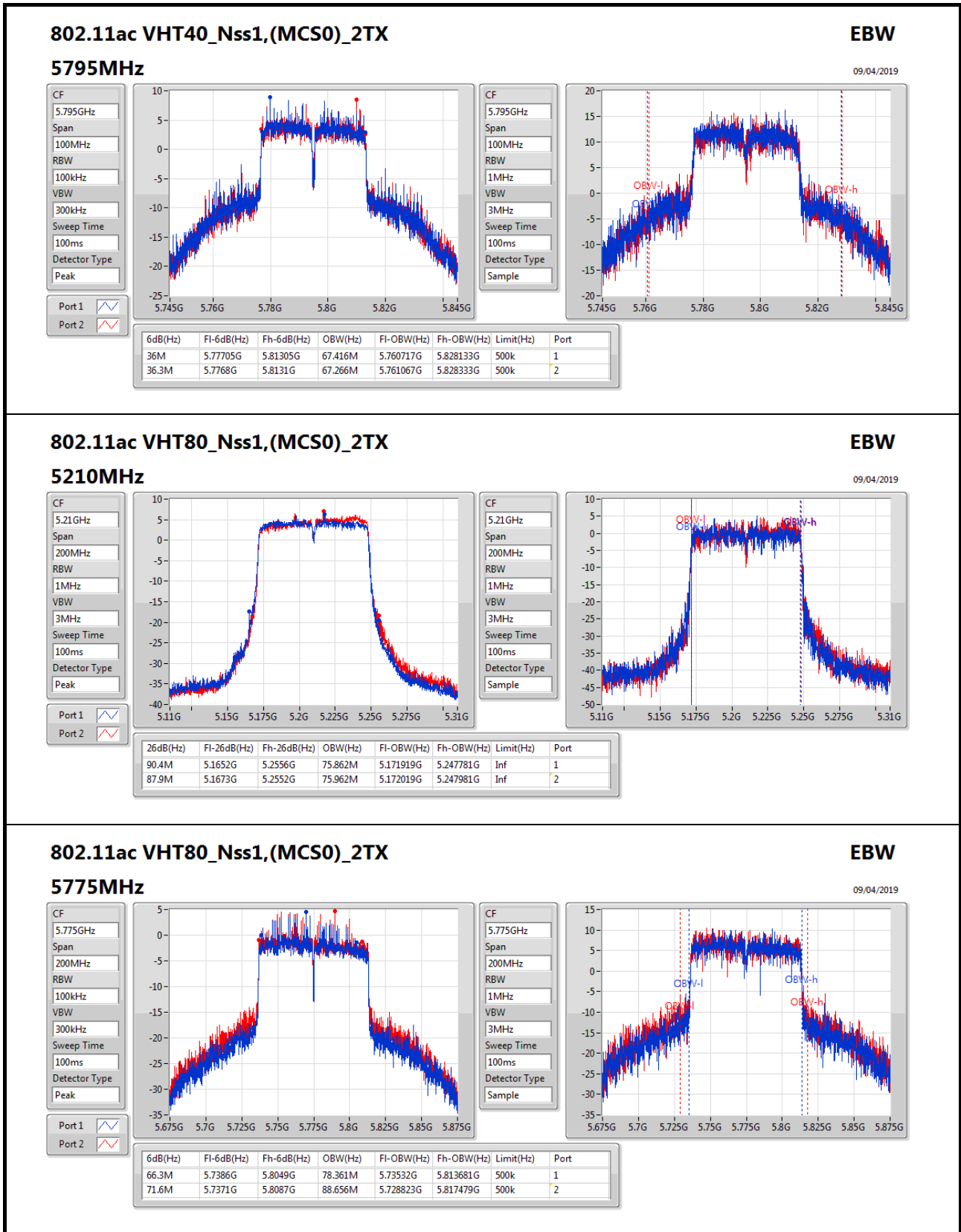



Power Result

Appendix C.1

For Radio 2 Summary

Mode	Total Power (dBm)	Total Power (W)
5.15-5.25GHz	-	-
802.11a_Nss1,(6Mbps)_4TX	27.47	0.55847
802.11ac VHT20_Nss1,(MCS0)_4TX	27.64	0.58076
802.11ac VHT40_Nss1,(MCS0)_4TX	27.15	0.51880
802.11ac VHT80_Nss1,(MCS0)_4TX	24.40	0.27542
5.725-5.85GHz	-	-
802.11a_Nss1,(6Mbps)_4TX	29.32	0.85507
802.11ac VHT20_Nss1,(MCS0)_4TX	29.24	0.83946
802.11ac VHT40_Nss1,(MCS0)_4TX	29.03	0.79983
802.11ac VHT80_Nss1,(MCS0)_4TX	26.66	0.46345



Power Result

Appendix C.1

Result

Mode	Result	DG (dBi)	Port 1 (dBm)	Port 2 (dBm)	Port 3 (dBm)	Port 4 (dBm)	Total Power (dBm)	Power Limit (dBm)
802.11a_Nss1,(6Mbps)_4TX	-	-	-	-	-	-	-	-
5180MHz	Pass	1.54	21.39	21.47	21.59	21.35	27.47	30.00
5200MHz	Pass	1.54	21.31	21.45	21.56	21.39	27.45	30.00
5240MHz	Pass	1.54	21.41	21.48	21.52	21.33	27.46	30.00
5745MHz	Pass	1.54	23.05	23.30	23.17	23.13	29.18	30.00
5785MHz	Pass	1.54	23.17	23.40	23.35	23.16	29.29	30.00
5825MHz	Pass	1.54	23.37	23.37	23.30	23.17	29.32	30.00
802.11ac VHT20_Nss1,(MCS0)_4TX	-	-	-	-	-	-	-	-
5180MHz	Pass	1.54	21.42	21.83	21.65	21.54	27.63	30.00
5200MHz	Pass	1.54	21.53	21.87	21.61	21.46	27.64	30.00
5240MHz	Pass	1.54	21.49	21.78	21.55	21.39	27.58	30.00
5745MHz	Pass	1.54	22.20	22.72	22.39	22.52	28.48	30.00
5785MHz	Pass	1.54	23.06	23.38	23.33	23.09	29.24	30.00
5825MHz	Pass	1.54	23.19	23.19	23.20	23.11	29.19	30.00
802.11ac VHT40_Nss1,(MCS0)_4TX	-	-	-	-	-	-	-	-
5190MHz	Pass	1.54	20.51	20.66	20.42	20.50	26.54	30.00
5230MHz	Pass	1.54	21.15	21.45	20.99	20.92	27.15	30.00
5755MHz	Pass	1.54	22.61	23.21	23.10	23.01	29.01	30.00
5795MHz	Pass	1.54	23.04	23.29	23.09	22.60	29.03	30.00
802.11ac VHT80_Nss1,(MCS0)_4TX	-	-	-	-	-	-	-	-
5210MHz	Pass	1.54	18.38	18.77	18.26	18.07	24.40	30.00
5775MHz	Pass	1.54	20.46	20.73	20.77	20.58	26.66	30.00

DG = Directional Gain; Port X = Port X output power



Power Result

Appendix C.2

For Radio 3 Summary

Mode	Total Power (dBm)	Total Power (W)
5.15-5.25GHz	-	-
802.11a_Nss1,(6Mbps)_2TX	25.05	0.31989
802.11ac VHT20_Nss1,(MCS0)_2TX	25.44	0.34995
802.11ac VHT40_Nss1,(MCS0)_2TX	23.47	0.22233
802.11ac VHT80_Nss1,(MCS0)_2TX	17.13	0.05164
5.725-5.85GHz	-	-
802.11a_Nss1,(6Mbps)_2TX	25.83	0.38282
802.11ac VHT20_Nss1,(MCS0)_2TX	25.80	0.38019
802.11ac VHT40_Nss1,(MCS0)_2TX	25.63	0.36559
802.11ac VHT80_Nss1,(MCS0)_2TX	23.25	0.21135



Power Result

Appendix C.2

Result

Mode	Result	DG (dBi)	Port 1 (dBm)	Port 2 (dBm)	Total Power (dBm)	Power Limit (dBm)
802.11a_Nss1,(6Mbps)_2TX	-	-	-	-	-	-
5180MHz	Pass	3.24	19.01	19.45	22.25	30.00
5200MHz	Pass	3.24	21.88	22.20	25.05	30.00
5240MHz	Pass	3.24	20.77	20.92	23.86	30.00
5745MHz	Pass	3.24	22.95	22.68	25.83	30.00
5785MHz	Pass	3.24	22.94	22.55	25.76	30.00
5825MHz	Pass	3.24	22.61	22.94	25.79	30.00
802.11ac VHT20_Nss1,(MCS0)_2TX	-	-	-	-	-	-
5180MHz	Pass	3.24	18.56	19.03	21.81	30.00
5200MHz	Pass	3.24	22.34	22.51	25.44	30.00
5240MHz	Pass	3.24	20.80	21.05	23.94	30.00
5745MHz	Pass	3.24	22.82	22.76	25.80	30.00
5785MHz	Pass	3.24	21.22	22.47	24.90	30.00
5825MHz	Pass	3.24	22.47	22.83	25.66	30.00
802.11ac VHT40_Nss1,(MCS0)_2TX	-	-	-	-	-	-
5190MHz	Pass	3.24	17.00	17.11	20.07	30.00
5230MHz	Pass	3.24	20.53	20.38	23.47	30.00
5755MHz	Pass	3.24	22.00	21.65	24.84	30.00
5795MHz	Pass	3.24	22.65	22.58	25.63	30.00
802.11ac VHT80_Nss1,(MCS0)_2TX	-	-	-	-	-	-
5210MHz	Pass	3.24	13.85	14.37	17.13	30.00
5775MHz	Pass	3.24	20.12	20.36	23.25	30.00

DG = Directional Gain; Port X = Port X output power



**For Radio 2
Summary**

Mode	PD (dBm/RBW)
5.15-5.25GHz	-
802.11a_Nss1,(6Mbps)_4TX	14.11
802.11ac VHT20_Nss1,(MCS0)_4TX	14.28
802.11ac VHT40_Nss1,(MCS0)_4TX	10.79
802.11ac VHT80_Nss1,(MCS0)_4TX	5.21
5.725-5.85GHz	-
802.11a_Nss1,(6Mbps)_4TX	14.82
802.11ac VHT20_Nss1,(MCS0)_4TX	14.33
802.11ac VHT40_Nss1,(MCS0)_4TX	11.19
802.11ac VHT80_Nss1,(MCS0)_4TX	5.84

RBW = 500kHz for 5.725-5.85GHz band / 1MHz for other band;



PSD Result

Appendix D.1

Result

Mode	Result	DG (dBi)	Port 1 (dBm/RBW)	Port 2 (dBm/RBW)	Port 3 (dBm/RBW)	Port 4 (dBm/RBW)	PD (dBm/RBW)	PD Limit (dBm/RBW)
802.11a_Nss1,(6Mbps)_4TX	-	-	-	-	-	-	-	-
5180MHz	Pass	7.56	8.05	8.20	8.37	8.16	14.09	15.44
5200MHz	Pass	7.56	8.05	8.21	8.37	7.98	14.08	15.44
5240MHz	Pass	7.56	8.19	8.14	8.27	7.98	14.11	15.44
5745MHz	Pass	7.56	8.77	8.84	9.00	8.74	14.76	28.44
5785MHz	Pass	7.56	8.75	8.94	9.08	8.64	14.82	28.44
5825MHz	Pass	7.56	9.03	8.84	8.96	8.74	14.80	28.44
802.11ac VHT20_Nss1,(MCS0)_4TX	-	-	-	-	-	-	-	-
5180MHz	Pass	7.56	8.07	8.41	8.52	8.31	14.24	15.44
5200MHz	Pass	7.56	8.11	8.42	8.50	8.29	14.28	15.44
5240MHz	Pass	7.56	8.18	8.25	8.23	8.10	14.11	15.44
5745MHz	Pass	7.56	7.61	7.92	8.02	7.87	13.72	28.44
5785MHz	Pass	7.56	8.37	8.49	8.59	8.29	14.30	28.44
5825MHz	Pass	7.56	8.48	8.32	8.53	8.35	14.33	28.44
802.11ac VHT40_Nss1,(MCS0)_4TX	-	-	-	-	-	-	-	-
5190MHz	Pass	7.56	4.26	4.47	4.26	4.21	10.24	15.44
5230MHz	Pass	7.56	4.91	5.16	4.84	4.57	10.79	15.44
5755MHz	Pass	7.56	5.00	5.44	5.58	5.35	11.19	28.44
5795MHz	Pass	7.56	5.11	5.55	5.45	5.21	11.19	28.44
802.11ac VHT80_Nss1,(MCS0)_4TX	-	-	-	-	-	-	-	-
5210MHz	Pass	7.56	-0.50	-0.42	-0.73	-0.87	5.21	15.44
5775MHz	Pass	7.56	-0.13	0.19	0.05	-0.09	5.84	28.44

DG = Directional Gain; **RBW** = 500kHz for 5.725-5.85GHz band / 1MHz for other band;

PD = trace bin-by-bin of each transmits port summing can be performed maximum power density; **Port X** = Port Xpower density;

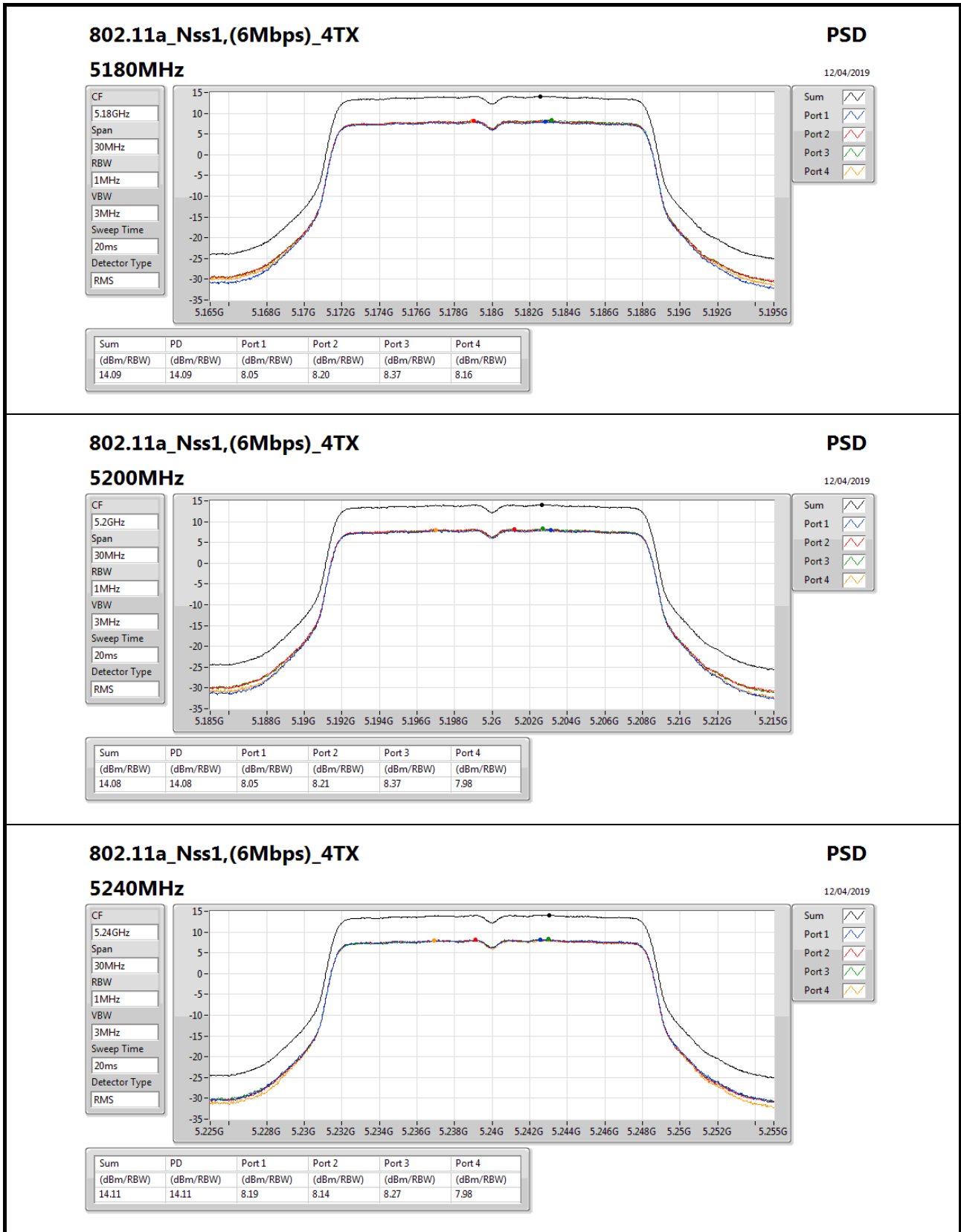

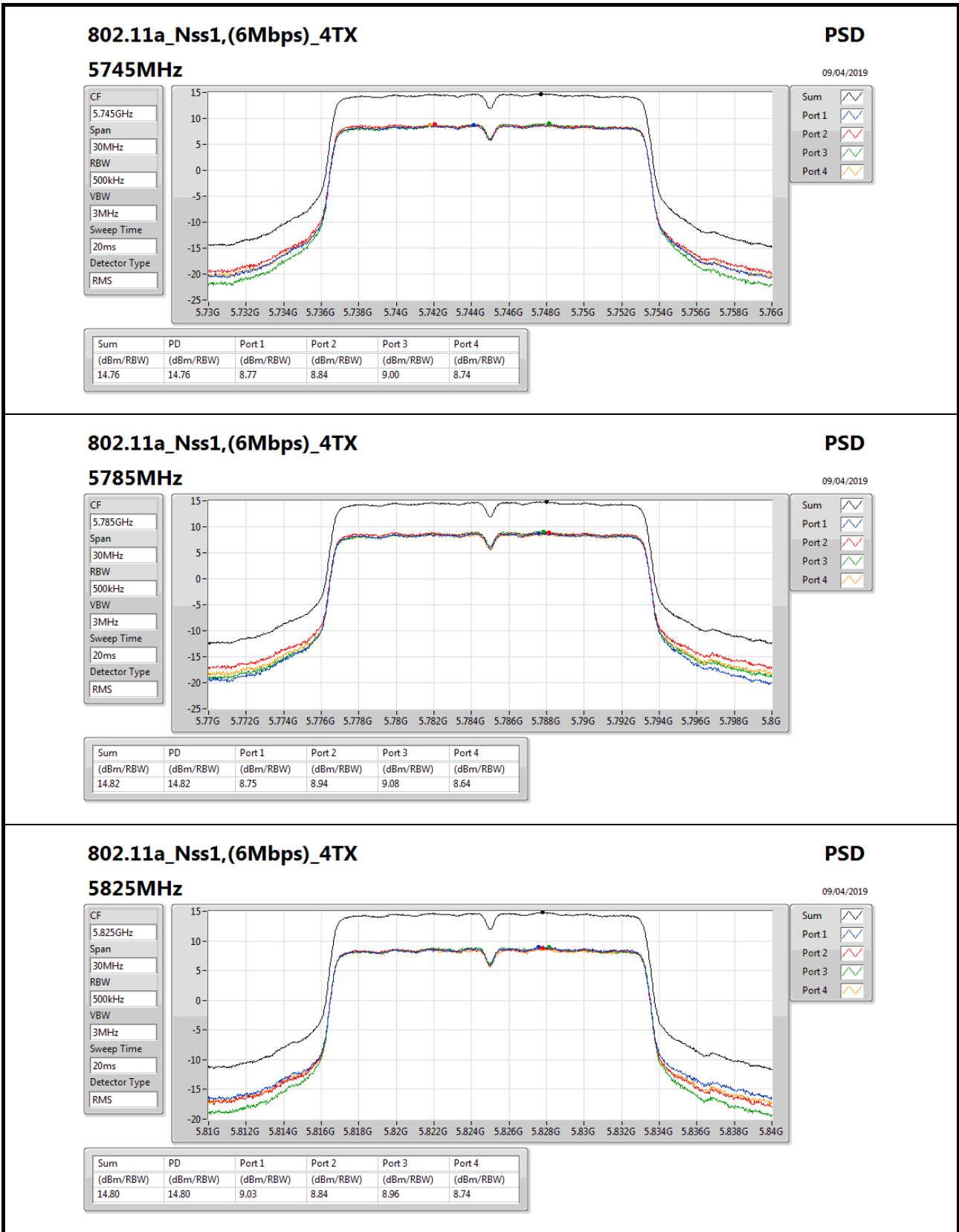

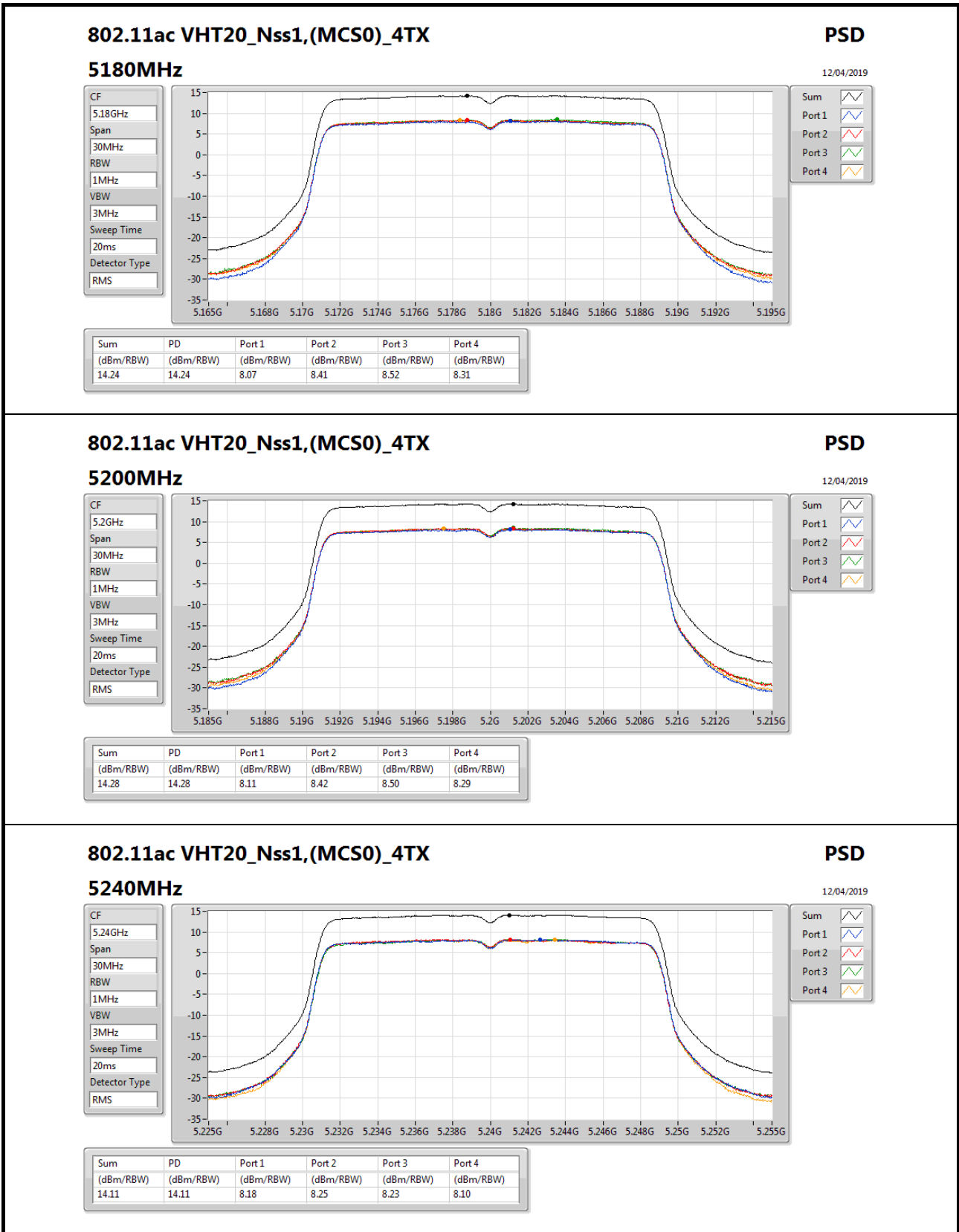

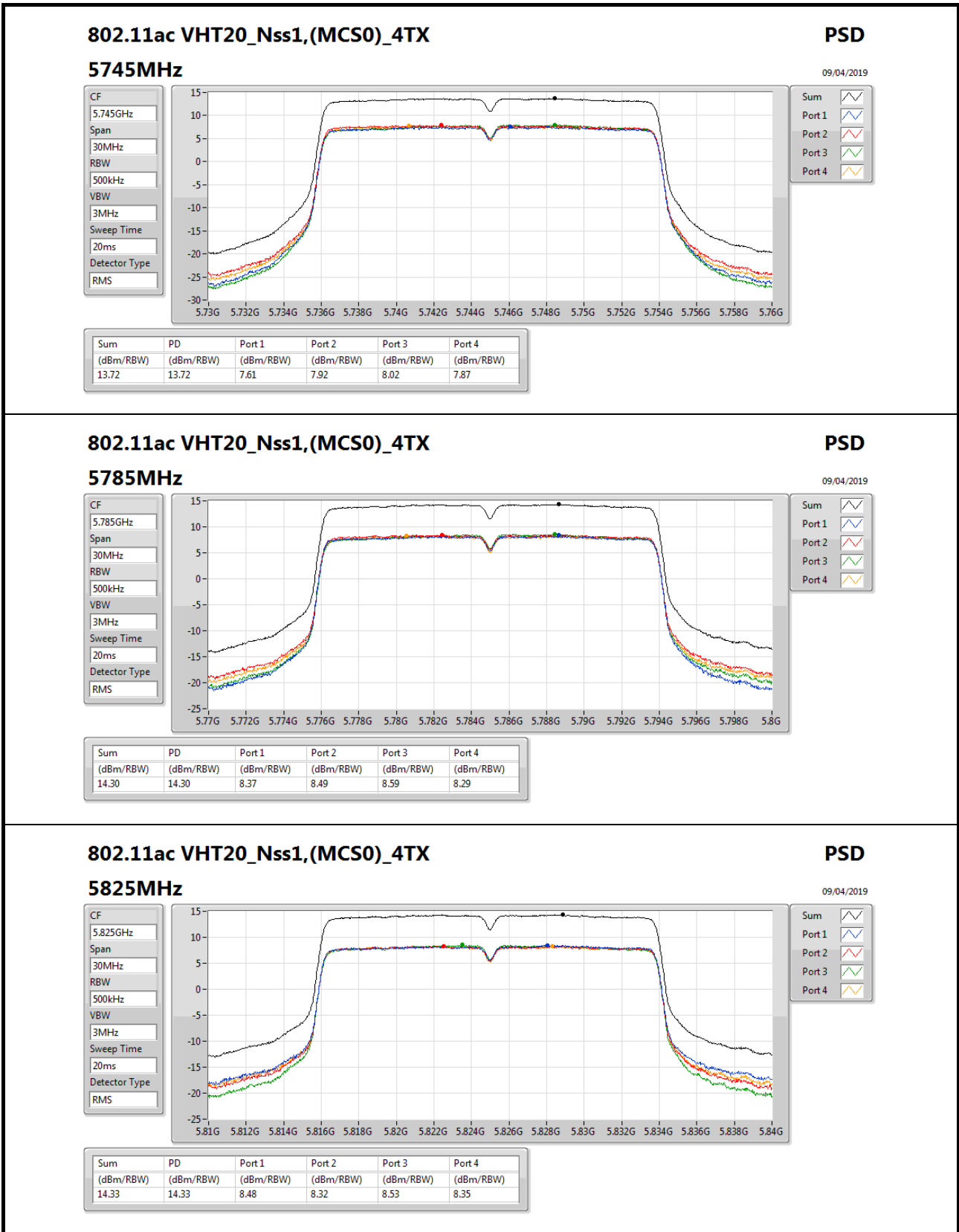

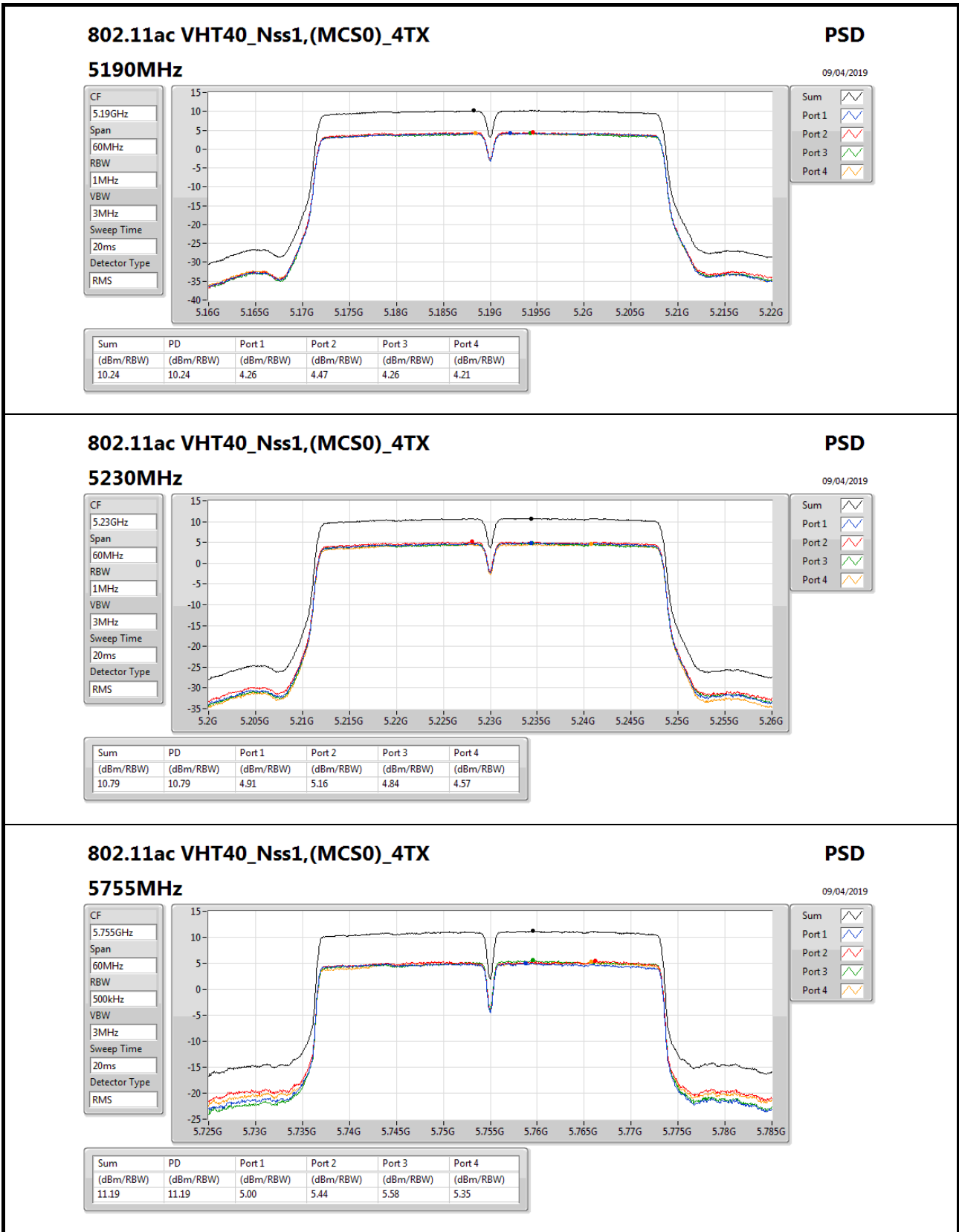

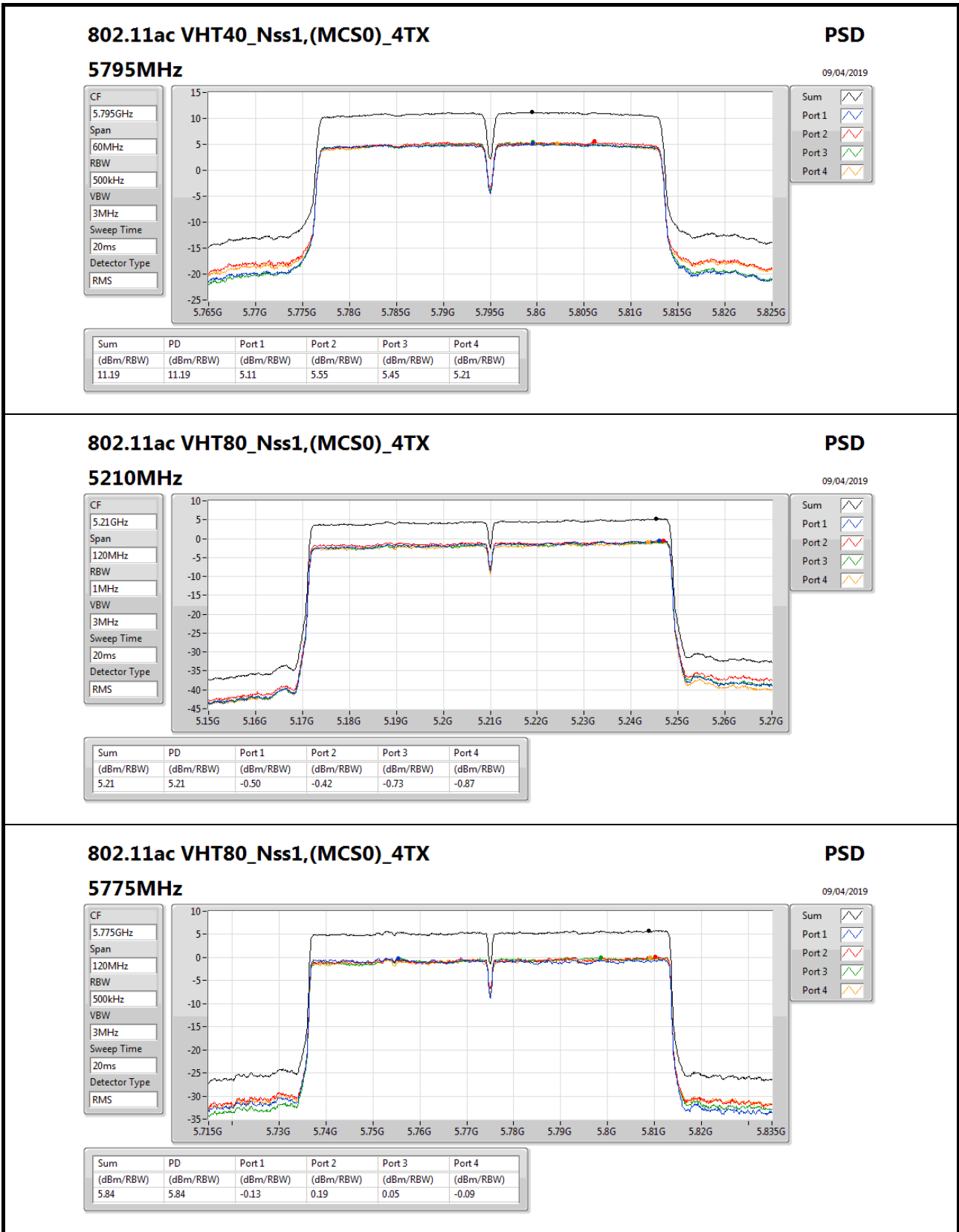



PSD Result

**For Radio 3
Summary**

Mode	PD (dBm/RBW)
5.15-5.25GHz	-
802.11a_Nss1,(6Mbps)_2TX	12.09
802.11ac VHT20_Nss1,(MCS0)_2TX	12.11
802.11ac VHT40_Nss1,(MCS0)_2TX	7.38
802.11ac VHT80_Nss1,(MCS0)_2TX	-1.54
5.725-5.85GHz	-
802.11a_Nss1,(6Mbps)_2TX	11.23
802.11ac VHT20_Nss1,(MCS0)_2TX	10.97
802.11ac VHT40_Nss1,(MCS0)_2TX	7.99
802.11ac VHT80_Nss1,(MCS0)_2TX	3.68

RBW = 500kHz for 5.725-5.85GHz band / 1MHz for other band;



PSD Result

Appendix D.2

Result

Mode	Result	DG (dBi)	Port 1 (dBm/RBW)	Port 2 (dBm/RBW)	PD (dBm/RBW)	PD Limit (dBm/RBW)
802.11a_Nss1,(6Mbps)_2TX	-	-	-	-	-	-
5180MHz	Pass	6.25	5.95	6.37	9.14	16.75
5200MHz	Pass	6.25	8.90	9.33	12.09	16.75
5240MHz	Pass	6.25	7.83	8.15	10.93	16.75
5745MHz	Pass	6.25	8.38	8.29	11.23	29.75
5785MHz	Pass	6.25	8.40	8.10	11.22	29.75
5825MHz	Pass	6.25	8.09	8.36	11.18	29.75
802.11ac VHT20_Nss1,(MCS0)_2TX	-	-	-	-	-	-
5180MHz	Pass	6.25	5.42	5.98	8.71	16.75
5200MHz	Pass	6.25	9.17	9.30	12.11	16.75
5240MHz	Pass	6.25	7.68	7.77	10.67	16.75
5745MHz	Pass	6.25	8.06	8.11	10.97	29.75
5785MHz	Pass	6.25	8.00	7.78	10.82	29.75
5825MHz	Pass	6.25	7.70	7.95	10.69	29.75
802.11ac VHT40_Nss1,(MCS0)_2TX	-	-	-	-	-	-
5190MHz	Pass	6.25	0.84	1.47	4.16	16.75
5230MHz	Pass	6.25	4.58	4.51	7.38	16.75
5755MHz	Pass	6.25	4.35	4.27	7.29	29.75
5795MHz	Pass	6.25	5.16	4.97	7.99	29.75
802.11ac VHT80_Nss1,(MCS0)_2TX	-	-	-	-	-	-
5210MHz	Pass	6.25	-4.81	-4.02	-1.54	16.75
5775MHz	Pass	6.25	0.33	1.07	3.68	29.75

DG = Directional Gain; **RBW** = 500kHz for 5.725-5.85GHz band / 1MHz for other band;

PD = trace bin-by-bin of each transmits port summing can be performed maximum power density; **Port X** = Port Xpower density;

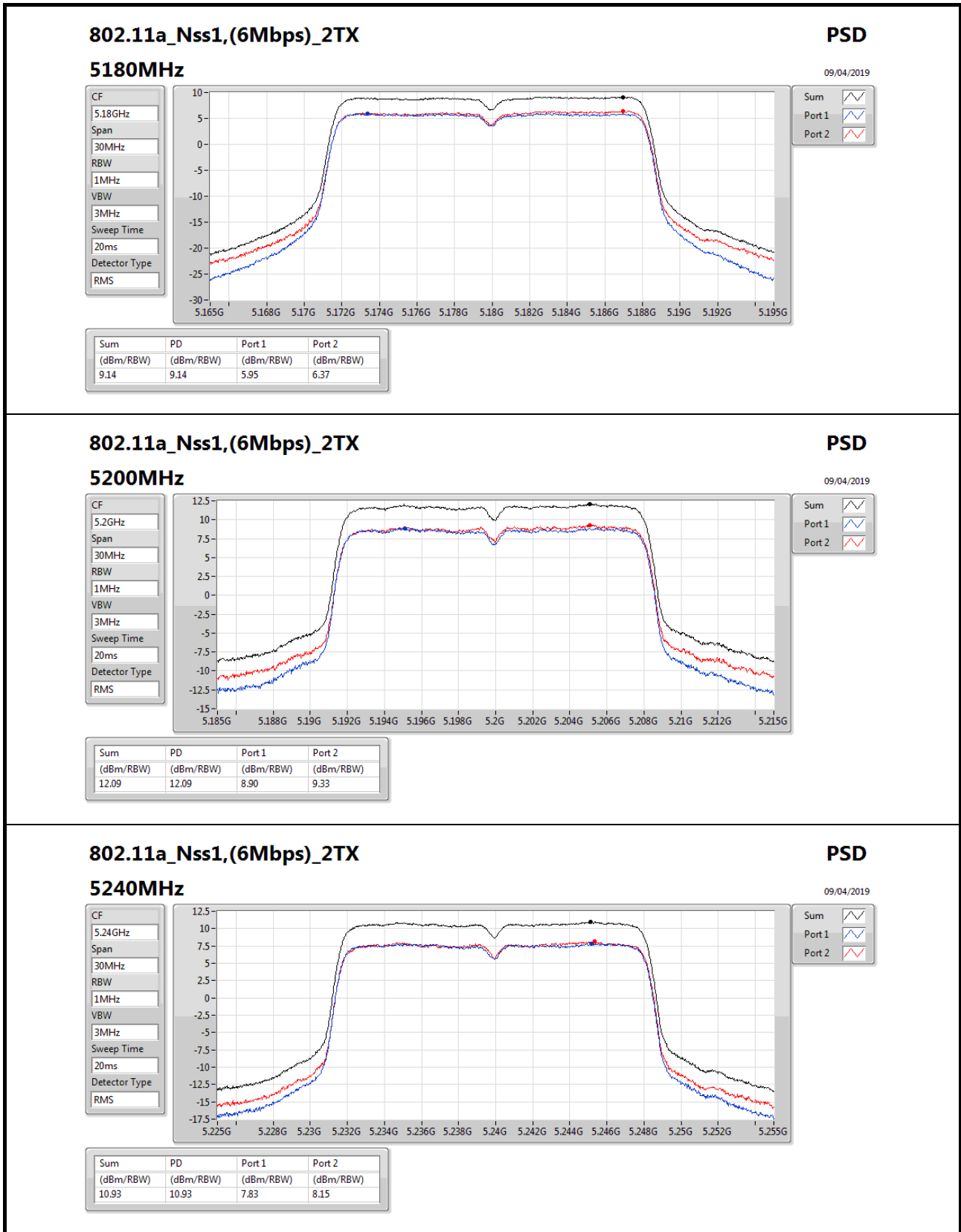

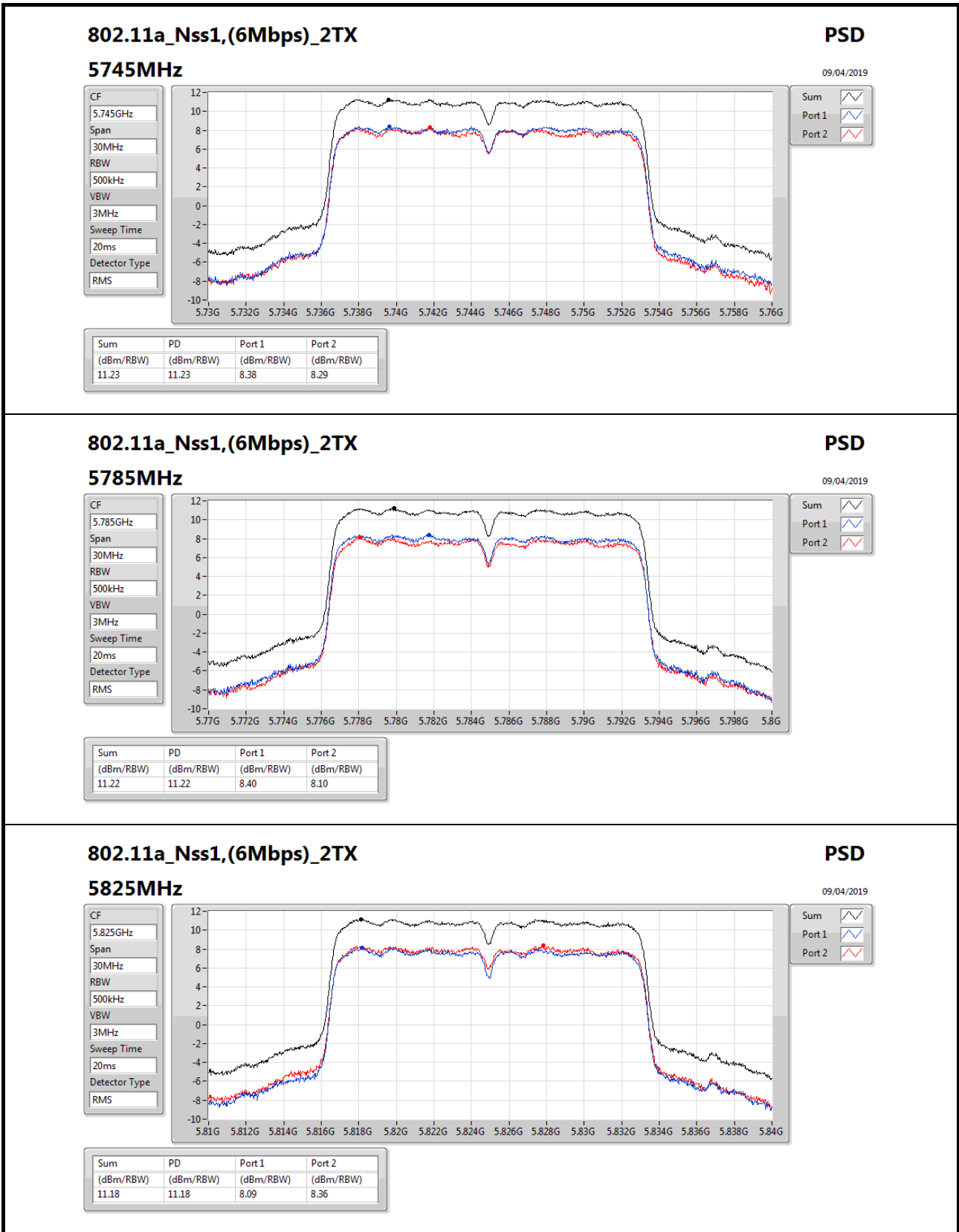

802.11a_Nss1,(6Mbps)_2TX

5825MHz

PSD

09/04/2019

CF
5.825GHz

Span
30MHz

RBW
500kHz

VBW
3MHz

Sweep Time
20ms

Detector Type
RMS



Sum 

Port 1 

Port 2 

Sum	PD	Port 1	Port 2
(dBm/RBW)	(dBm/RBW)	(dBm/RBW)	(dBm/RBW)
11.18	11.18	8.09	8.36

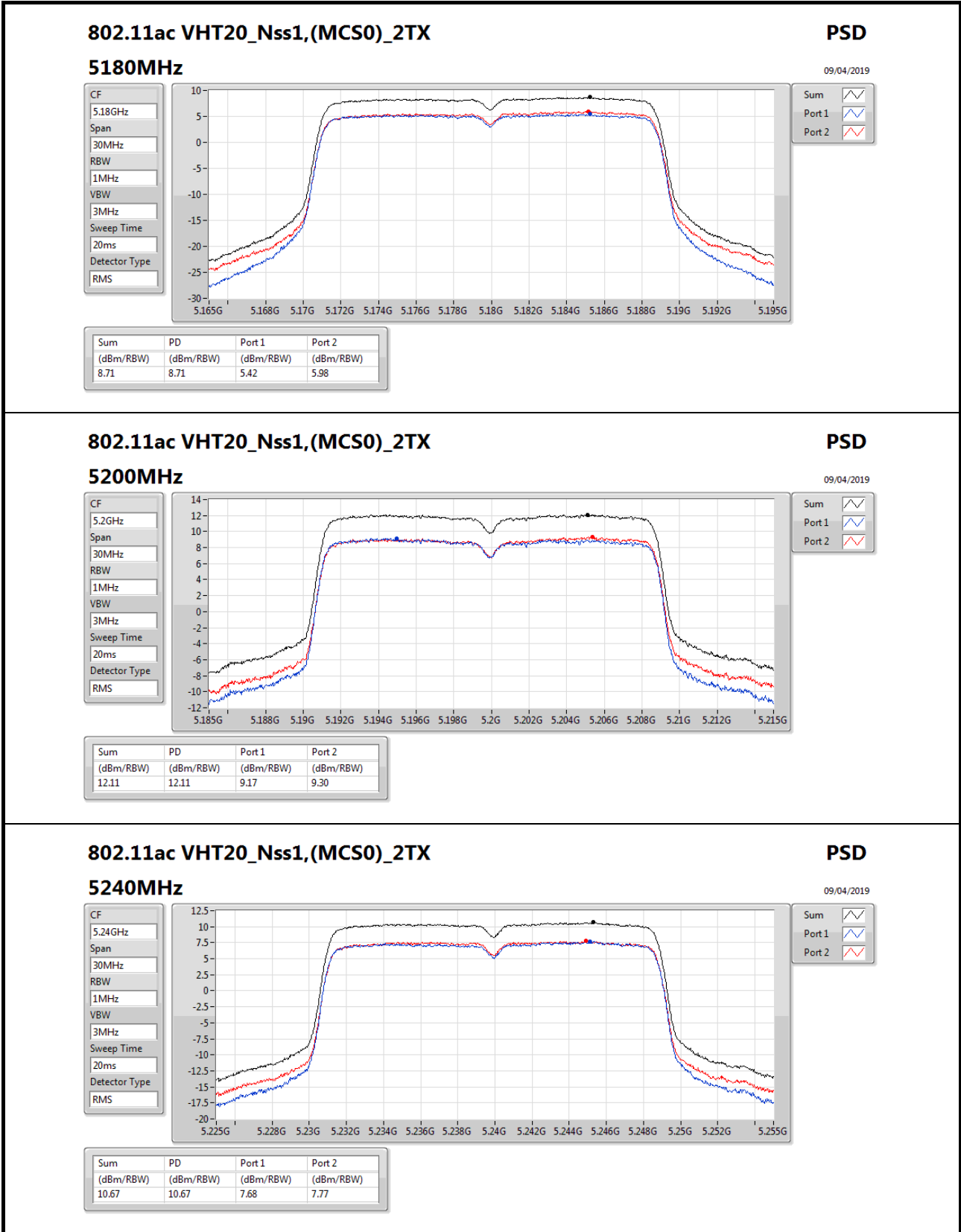

802.11ac VHT20_Nss1,(MCS0)_2TX

5240MHz

PSD

09/04/2019

CF
5.24GHz

Span
30MHz

RBW
1MHz

VBW
3MHz

Sweep Time
20ms

Detector Type
RMS



Sum 

Port 1 

Port 2 

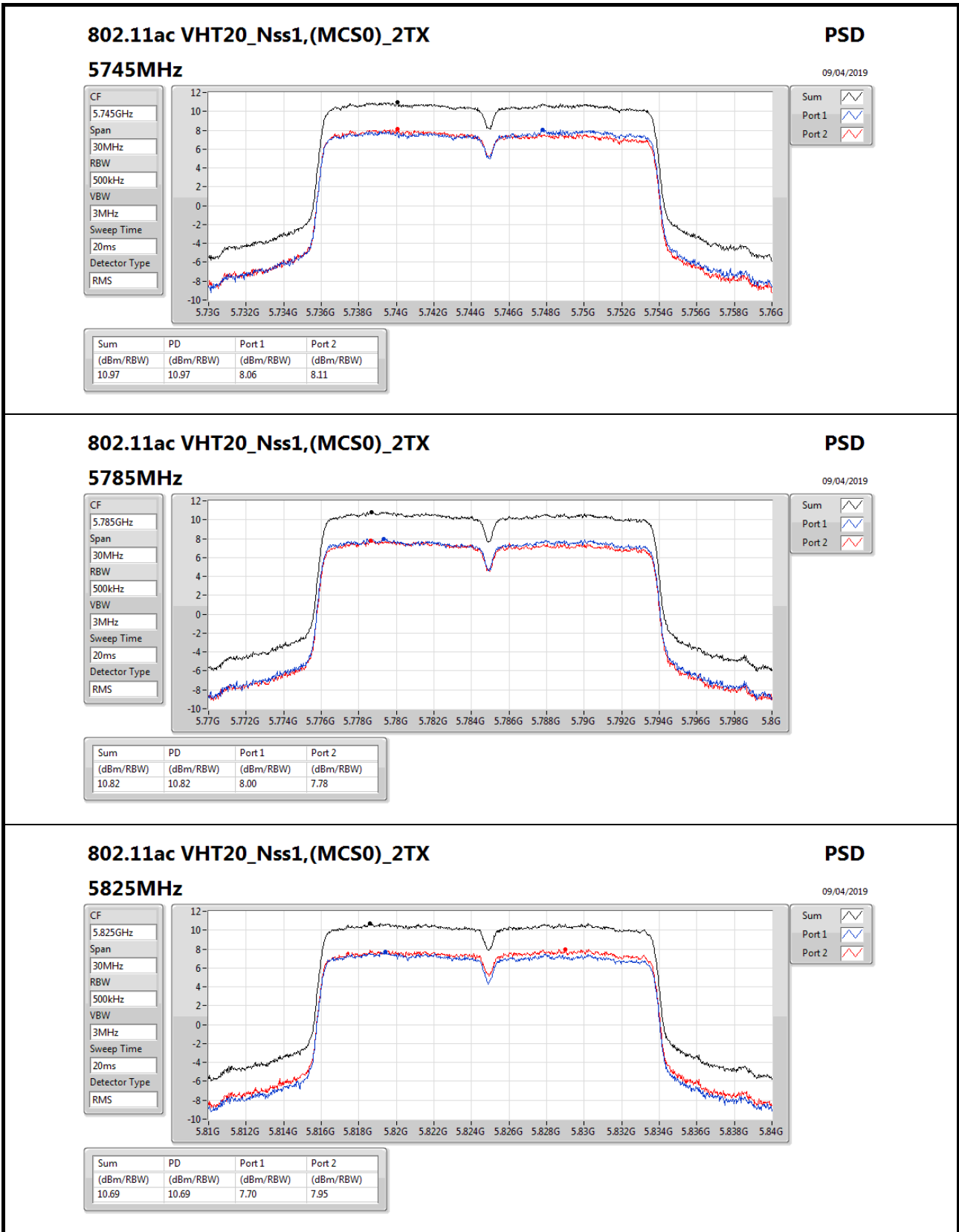

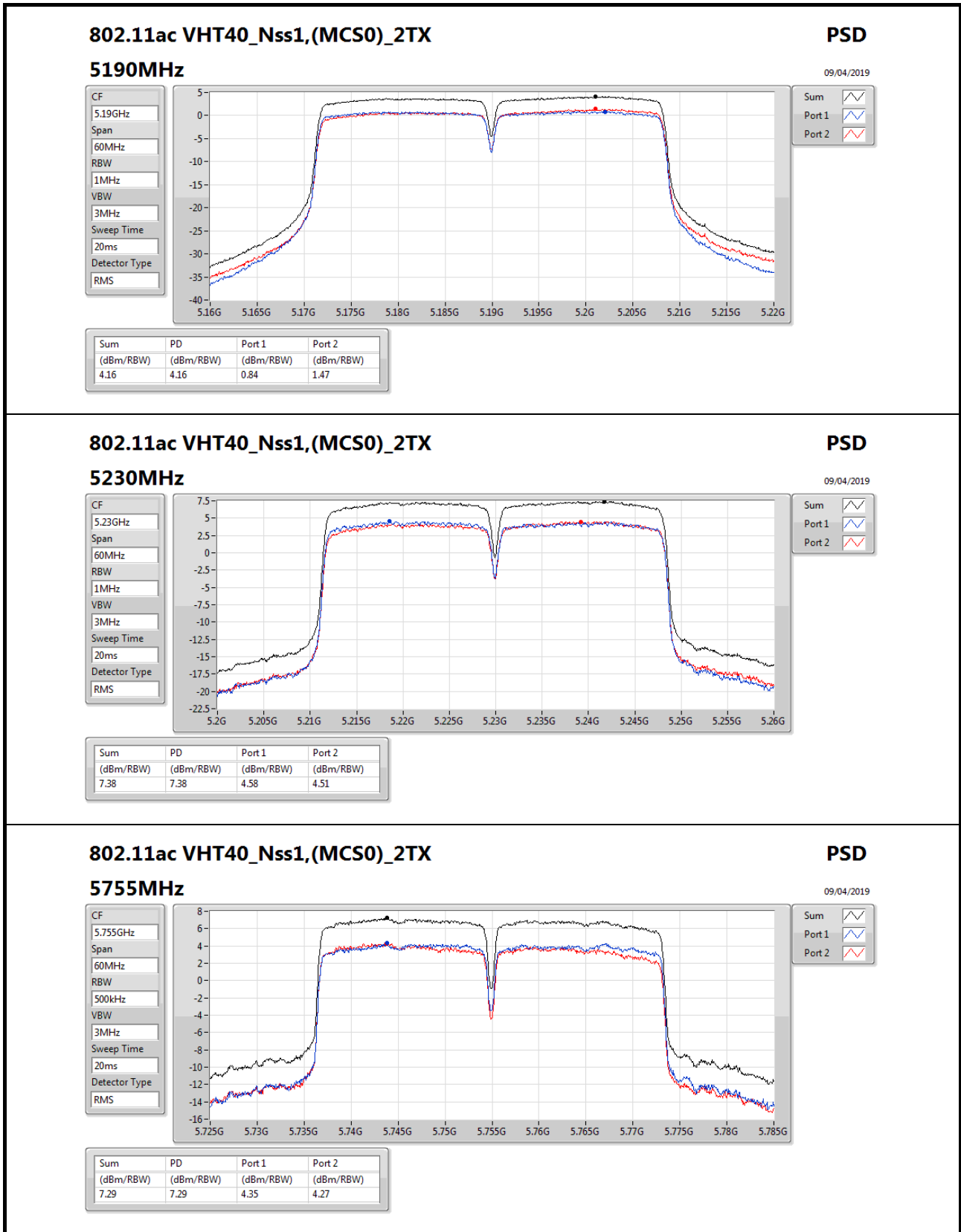

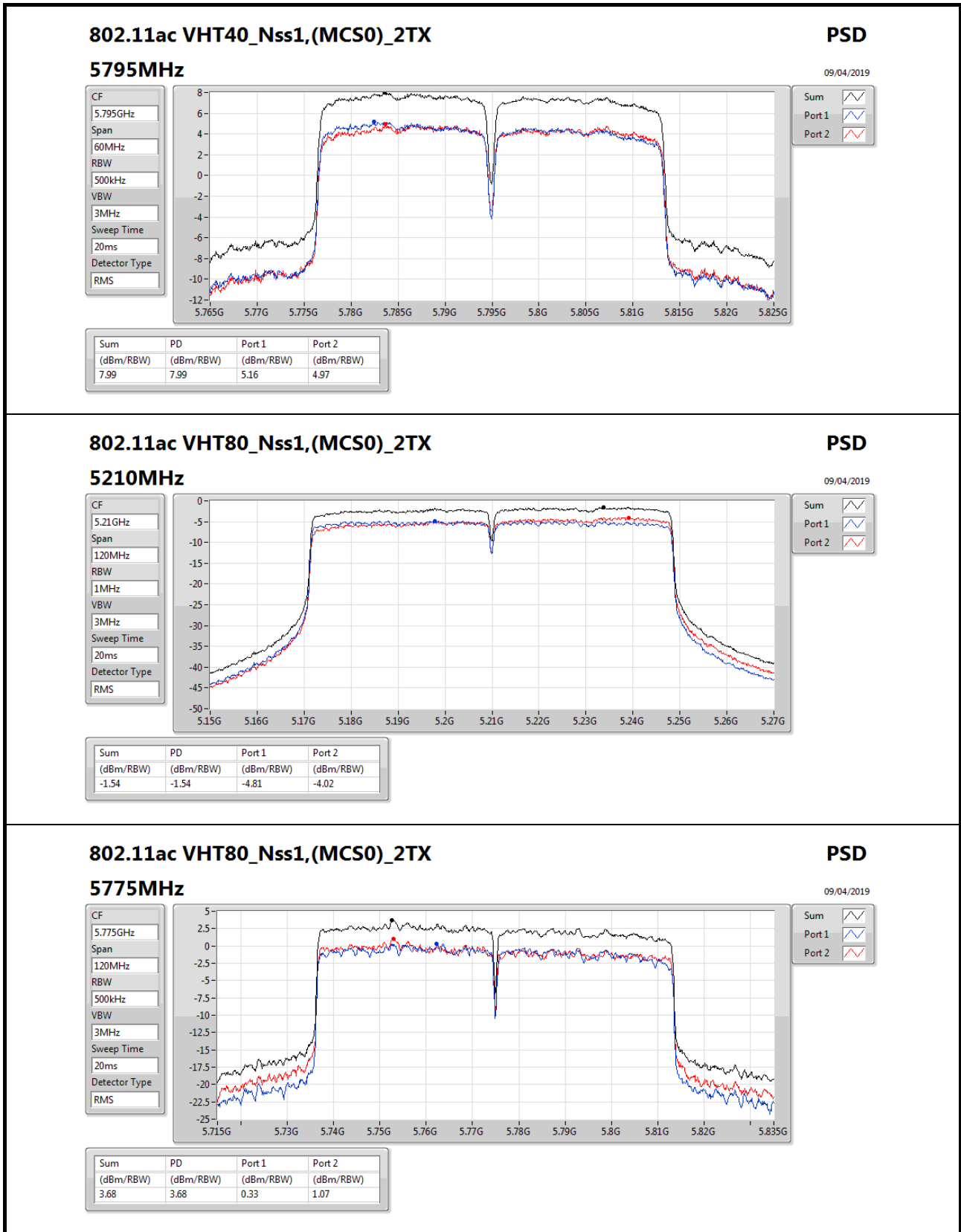

802.11ac VHT80_Nss1,(MCS0)_2TX

5775MHz

PSD

09/04/2019

CF
5.775GHz

Span
120MHz

RBW
500kHz

VBW
3MHz

Sweep Time
20ms

Detector Type
RMS



Sum

Port 1

Port 2



RSE below 1GHz Result

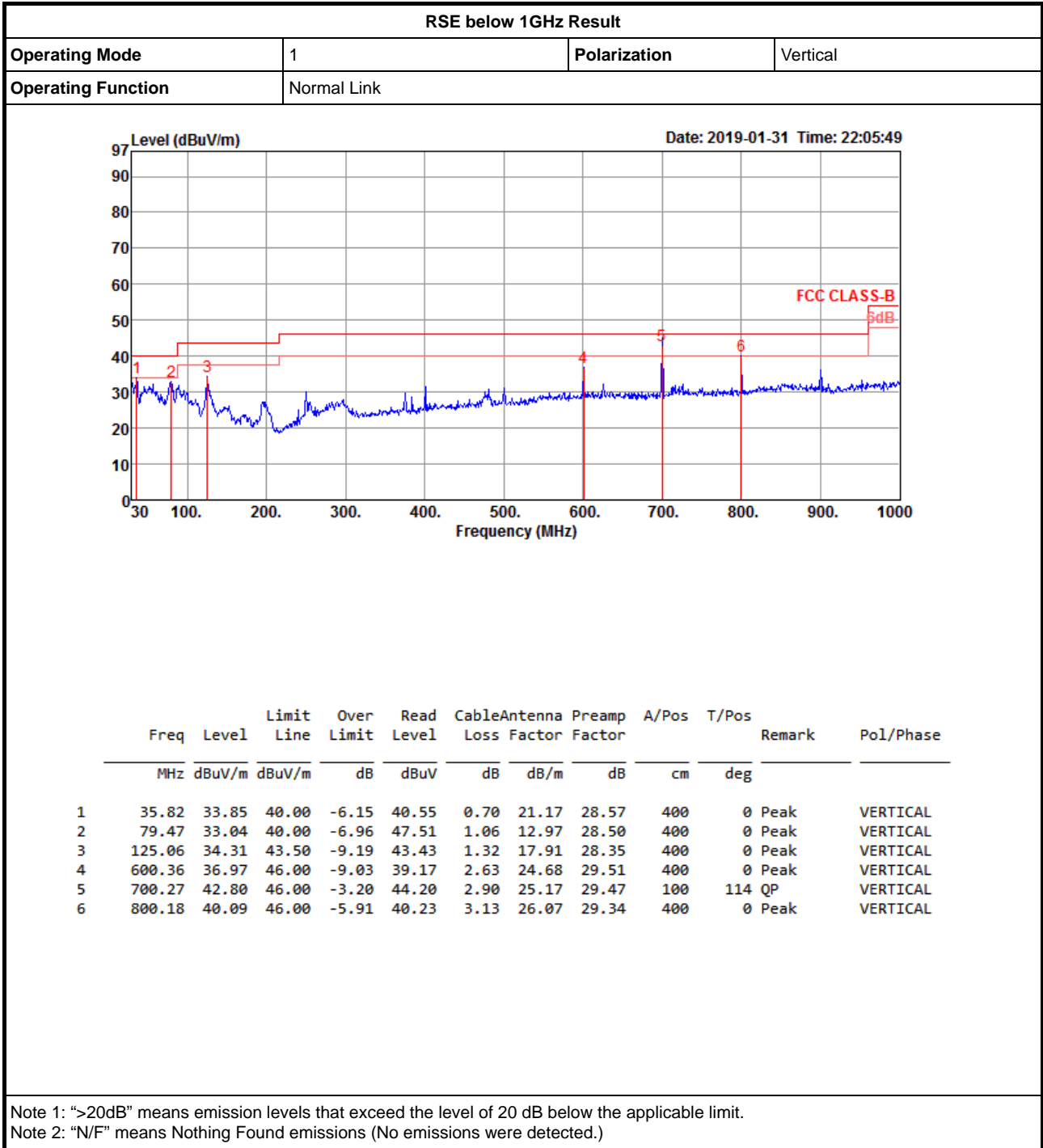



RSE below 1GHz Result

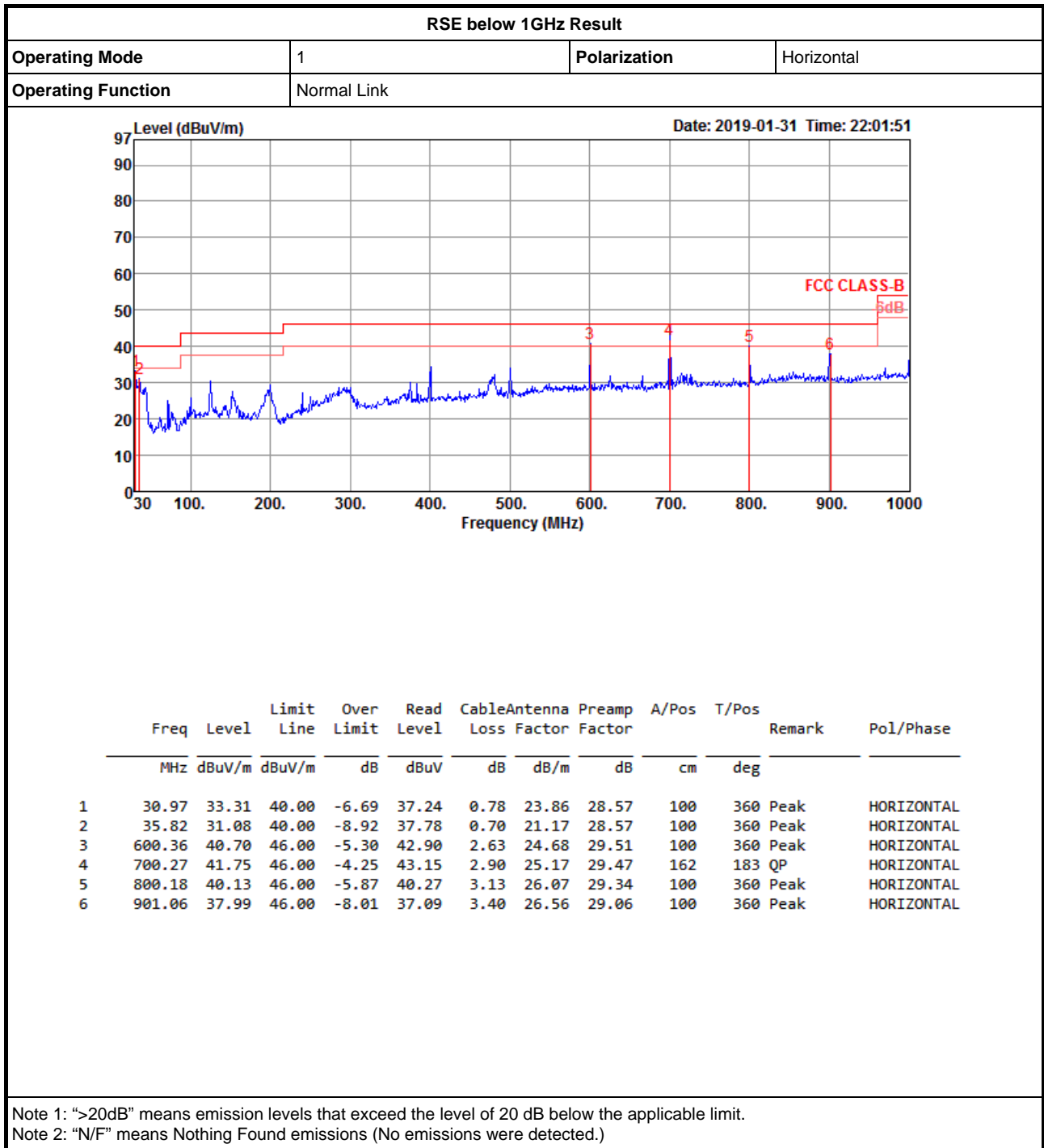



For Radio 2
Summary

Mode	Result	Type	Freq (Hz)	Level (dBuV/m)	Limit (dBuV/m)	Margin (dB)	Factor (dB)	Dist (m)	Condition	Azimuth (°)	Height (m)	Comments
5.15-5.25GHz	-	-	-	-	-	-	-	-	-	-	-	-
802.11a_Nss1,(6Mbps)_4TX	Pass	AV	5.1484G	53.98	54.00	-0.02	4.25	3	Horizontal	182	1.00	-

802.11a_Nss1,(6Mbps)_4TX

11/04/2019

5180MHz_TX

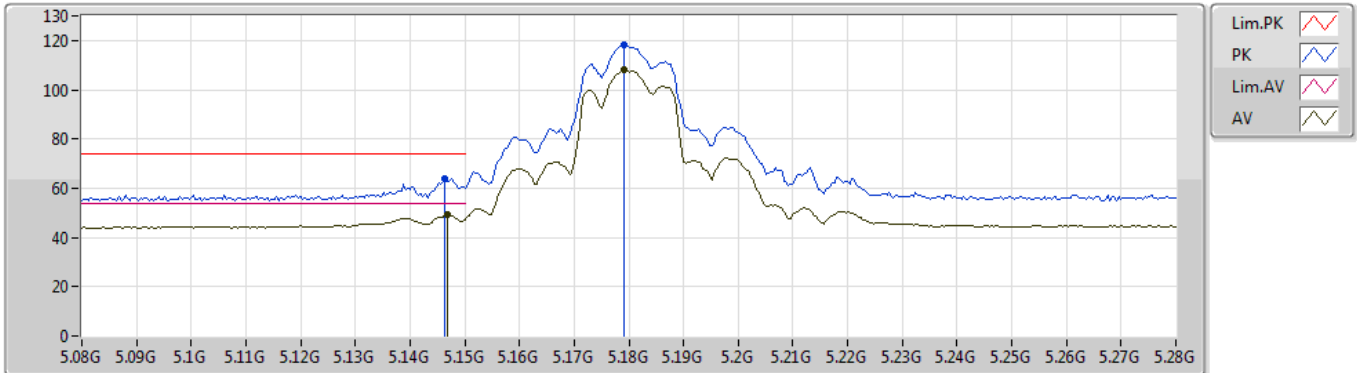

EUT Y_4TX
 Setting 21.5
 01-N-2-10
 Ant Dipole
 FSU(100015)

Type	Freq (Hz)	Level (dBuV/m)	Limit (dBuV/m)	Margin (dB)	Factor (dB)	Dist (m)	Condition	Azimuth (°)	Height (m)	Comment
PK	5.1464G	64.02	74.00	-9.98	4.25	3	Vertical	54	1.95	-
AV	5.1468G	49.52	54.00	-4.48	4.25	3	Vertical	54	1.95	-
PK	5.1792G	118.01	Inf	-Inf	4.26	3	Vertical	54	1.95	-
AV	5.1792G	108.01	Inf	-Inf	4.26	3	Vertical	54	1.95	-

802.11a_Nss1,(6Mbps)_4TX

11/04/2019

5180MHz_TX

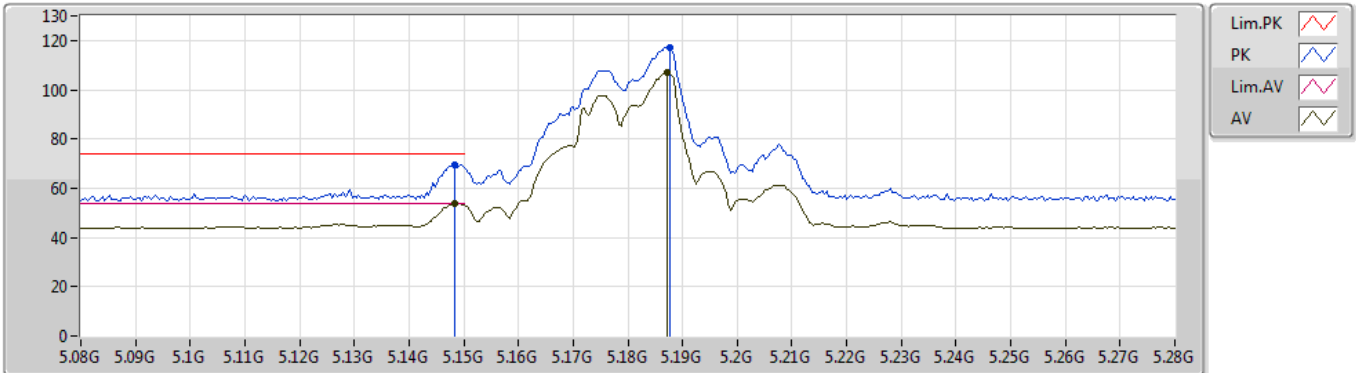

EUT Y_4TX
 Setting 21.5
 01-N-2-10
 Ant Dipole
 FSU(100015)

Type	Freq (Hz)	Level (dBuV/m)	Limit (dBuV/m)	Margin (dB)	Factor (dB)	Dist (m)	Condition	Azimuth (°)	Height (m)	Comment
PK	5.1484G	69.57	74.00	-4.43	4.25	3	Horizontal	182	1.00	-
AV	5.1484G	53.98	54.00	-0.02	4.25	3	Horizontal	182	1.00	-
PK	5.1876G	117.29	Inf	-Inf	4.26	3	Horizontal	182	1.00	-
AV	5.1872G	107.03	Inf	-Inf	4.27	3	Horizontal	182	1.00	-

802.11a_Nss1,(6Mbps)_4TX

11/04/2019

5180MHz_TX

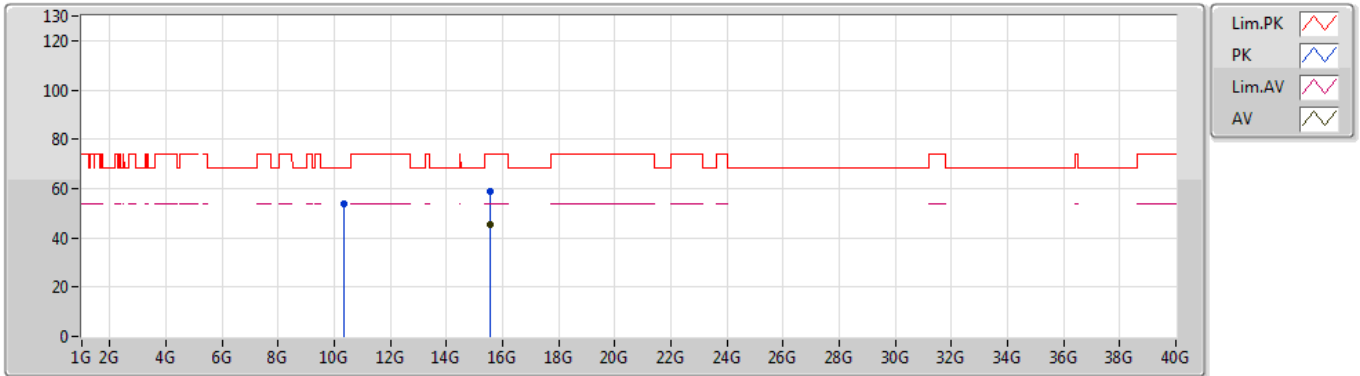

EUT Y_4TX
 Setting 21.5
 01-M-1
 Ant Dipole
 FSU(100015)

Type	Freq (Hz)	Level (dBuV/m)	Limit (dBuV/m)	Margin (dB)	Factor (dB)	Dist (m)	Condition	Azimuth (°)	Height (m)	Comment
PK	10.3587G	53.78	68.20	-14.42	10.85	3	Vertical	214	2.14	-
PK	15.53664G	58.80	74.00	-15.20	14.46	3	Vertical	9	1.49	-
AV	15.53672G	45.39	54.00	-8.61	14.46	3	Vertical	9	1.49	-

802.11a_Nss1,(6Mbps)_4TX

11/04/2019

5180MHz_TX

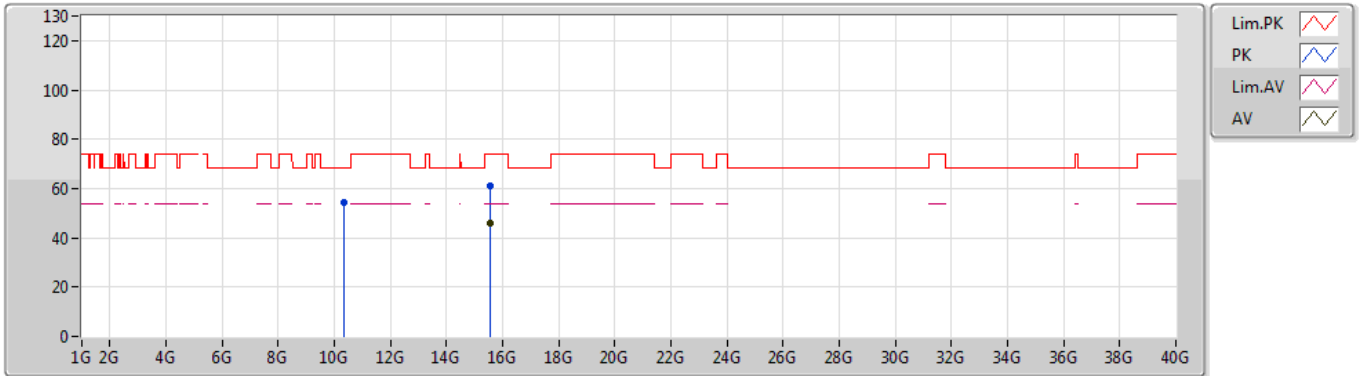

EUT Y_4TX
Setting 21.5
01-M-1
Ant Dipole
FSU(100015)

Type	Freq (Hz)	Level (dBuV/m)	Limit (dBuV/m)	Margin (dB)	Factor (dB)	Dist (m)	Condition	Azimuth (°)	Height (m)	Comment
PK	10.35965G	54.21	68.20	-13.99	10.85	3	Horizontal	254	2.84	-
PK	15.53508G	60.83	74.00	-13.17	14.46	3	Horizontal	24	1.33	-
AV	15.5356G	46.20	54.00	-7.80	14.46	3	Horizontal	24	1.33	-

802.11a_Nss1,(6Mbps)_4TX

11/04/2019

5200MHz_TX

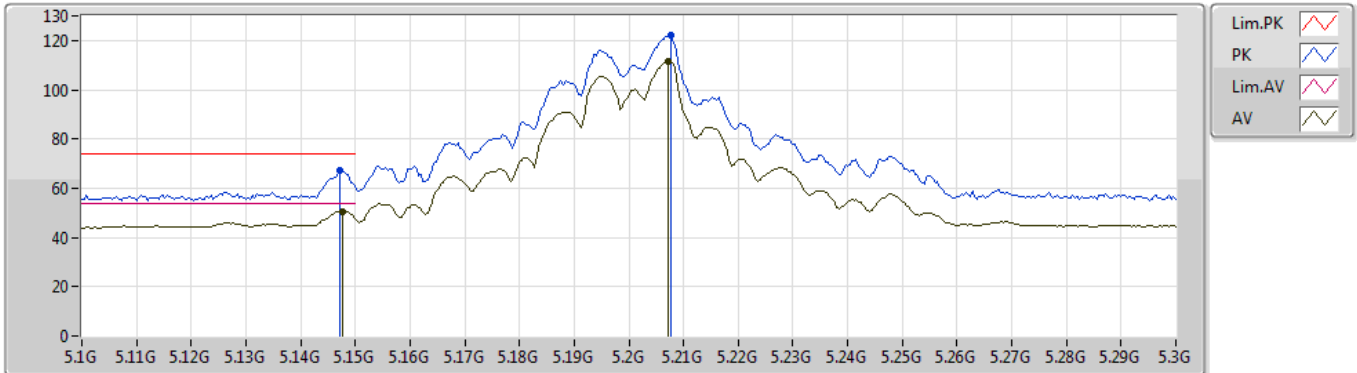

EUT_Y_4TX
Setting 24
01-N-2-10
Ant Dipole
FSU(100015)

Type	Freq (Hz)	Level (dBuV/m)	Limit (dBuV/m)	Margin (dB)	Factor (dB)	Dist (m)	Condition	Azimuth (°)	Height (m)	Comment
PK	5.1472G	67.51	74.00	-6.49	4.25	3	Vertical	65	2.25	-
AV	5.1476G	50.66	54.00	-3.34	4.25	3	Vertical	65	2.25	-
PK	5.2076G	121.90	Inf	-Inf	4.30	3	Vertical	65	2.25	-
AV	5.2072G	111.48	Inf	-Inf	4.30	3	Vertical	65	2.25	-

802.11a_Nss1,(6Mbps)_4TX

11/04/2019

5200MHz_TX

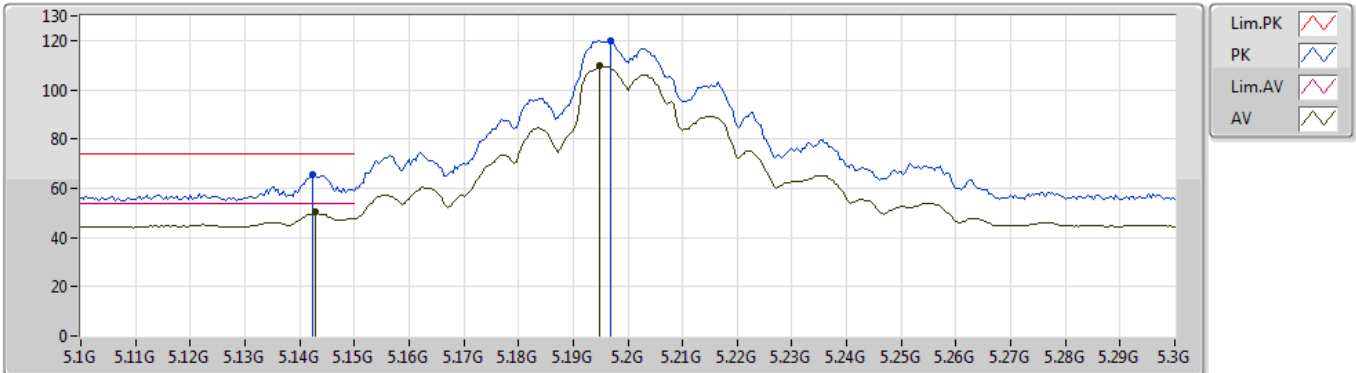

EUT Y_4TX
 Setting 24
 01-N-2-10
 Ant Dipole
 FSU(100015)

Type	Freq (Hz)	Level (dBuV/m)	Limit (dBuV/m)	Margin (dB)	Factor (dB)	Dist (m)	Condition	Azimuth (°)	Height (m)	Comment
PK	5.1424G	65.69	74.00	-8.31	4.24	3	Horizontal	177	1.33	-
AV	5.1428G	50.17	54.00	-3.83	4.24	3	Horizontal	177	1.33	-
PK	5.1968G	119.95	Inf	-Inf	4.27	3	Horizontal	177	1.33	-
AV	5.1948G	109.66	Inf	-Inf	4.26	3	Horizontal	177	1.33	-

802.11a_Nss1,(6Mbps)_4TX

11/04/2019

5200MHz_TX

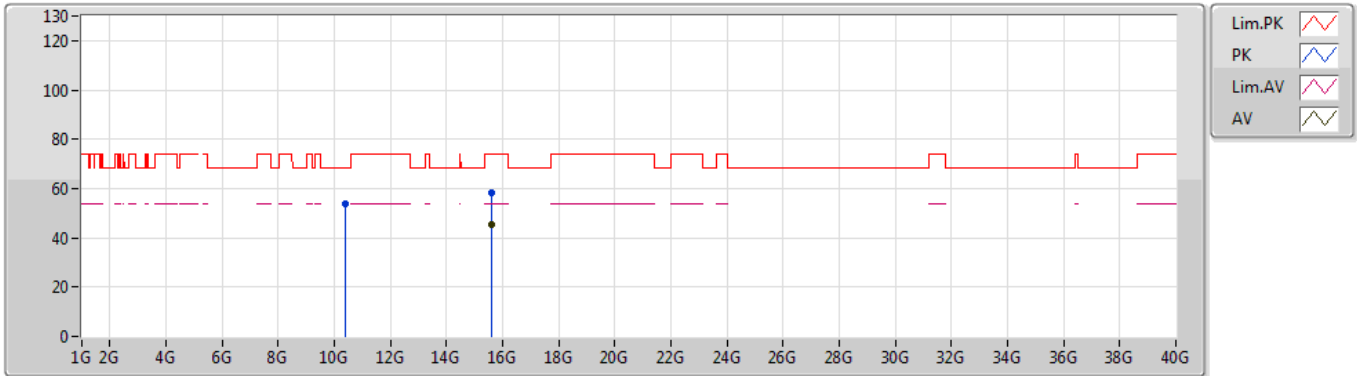

EUT Y_4TX
Setting 24
01-M-1
Ant Dipole
FSU(100015)

Type	Freq (Hz)	Level (dBuV/m)	Limit (dBuV/m)	Margin (dB)	Factor (dB)	Dist (m)	Condition	Azimuth (°)	Height (m)	Comment
PK	10.39844G	53.69	68.20	-14.51	10.91	3	Vertical	147	1.95	-
PK	15.59552G	58.39	74.00	-15.61	14.39	3	Vertical	9	1.50	-
AV	15.5957G	45.25	54.00	-8.75	14.39	3	Vertical	9	1.50	-

802.11a_Nss1,(6Mbps)_4TX

11/04/2019

5200MHz_TX

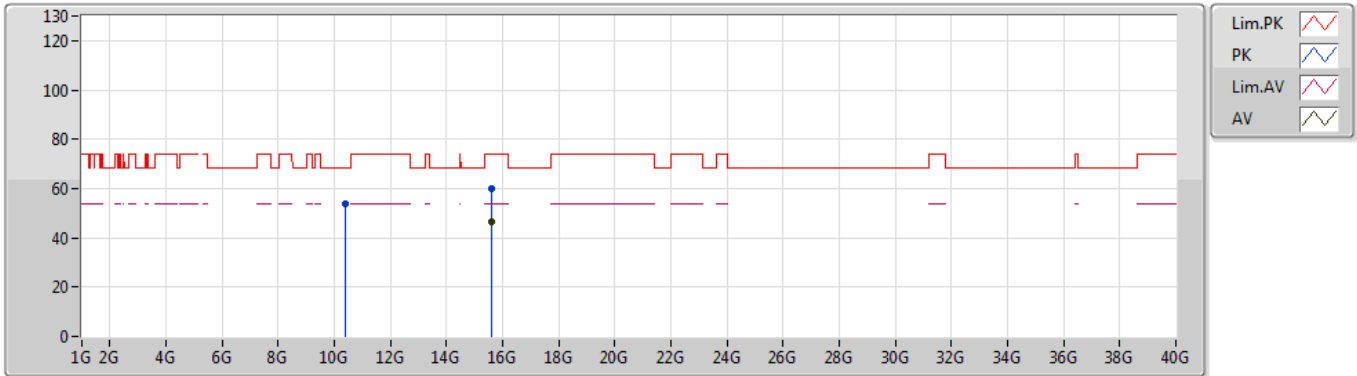

EUT Y_4TX
Setting 24
01-M-1
Ant Dipole
FSU(100015)

Type	Freq (Hz)	Level (dBuV/m)	Limit (dBuV/m)	Margin (dB)	Factor (dB)	Dist (m)	Condition	Azimuth (°)	Height (m)	Comment
PK	10.39953G	54.00	68.20	-14.20	10.91	3	Horizontal	274	2.22	-
PK	15.59514G	59.75	74.00	-14.25	14.39	3	Horizontal	23	1.46	-
AV	15.59612G	46.26	54.00	-7.74	14.39	3	Horizontal	23	1.46	-

802.11a_Nss1,(6Mbps)_4TX

11/04/2019

5240MHz_TX

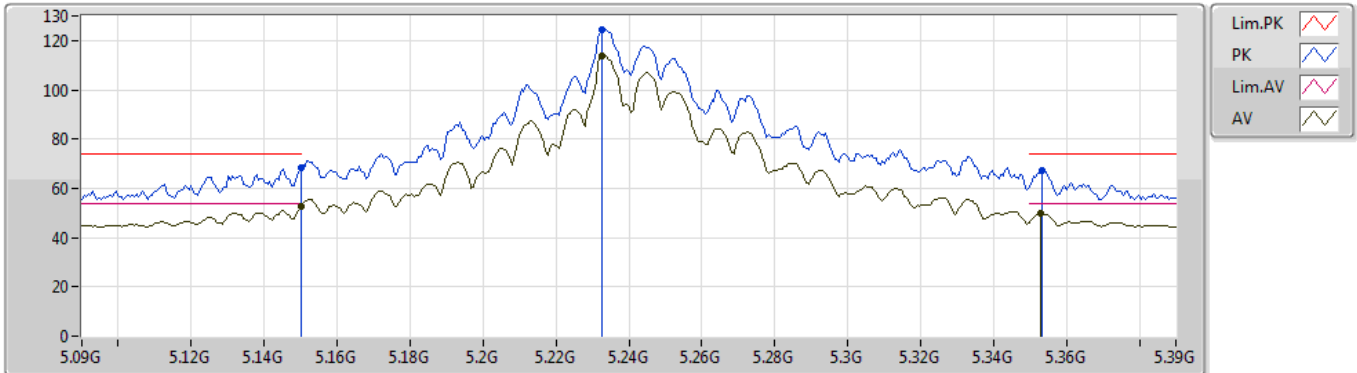

EUT_Y_4TX
 Setting 25.5
 01-M-1-10
 Ant Dipole
 FSU(100015)

Type	Freq (Hz)	Level (dBuV/m)	Limit (dBuV/m)	Margin (dB)	Factor (dB)	Dist (m)	Condition	Azimuth (°)	Height (m)	Comment
PK	5.15G	68.31	74.00	-5.69	4.25	3	Vertical	62	1.66	-
AV	5.15G	52.75	54.00	-1.25	4.25	3	Vertical	62	1.66	-
PK	5.2328G	124.62	Inf	-Inf	4.39	3	Vertical	62	1.66	-
AV	5.2328G	113.97	Inf	-Inf	4.39	3	Vertical	62	1.66	-
PK	5.3534G	67.46	74.00	-6.54	4.82	3	Vertical	62	1.66	-
AV	5.3528G	49.84	54.00	-4.16	4.82	3	Vertical	62	1.66	-

802.11a_Nss1,(6Mbps)_4TX

11/04/2019

5240MHz_TX

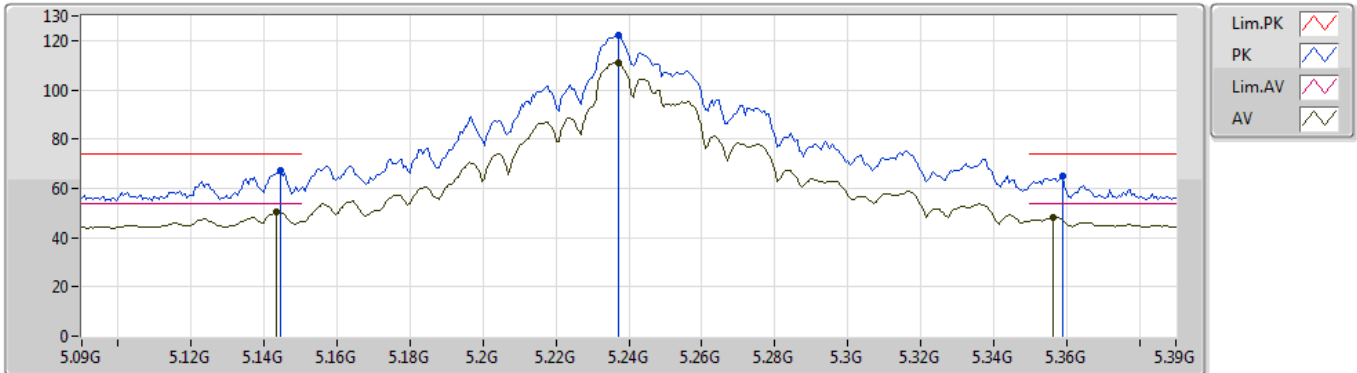

EUT_Y_4TX
 Setting 25.5
 01-M-1-10
 Ant Dipole
 FSU(100015)

Type	Freq (Hz)	Level (dBuV/m)	Limit (dBuV/m)	Margin (dB)	Factor (dB)	Dist (m)	Condition	Azimuth (°)	Height (m)	Comment
PK	5.1446G	67.05	74.00	-6.95	4.24	3	Horizontal	177	1.44	-
AV	5.1434G	50.60	54.00	-3.40	4.24	3	Horizontal	177	1.44	-
PK	5.237G	122.10	Inf	-Inf	4.41	3	Horizontal	177	1.44	-
AV	5.237G	111.19	Inf	-Inf	4.41	3	Horizontal	177	1.44	-
PK	5.3588G	64.83	74.00	-9.17	4.85	3	Horizontal	177	1.44	-
AV	5.3564G	48.23	54.00	-5.77	4.83	3	Horizontal	177	1.44	-

802.11a_Nss1,(6Mbps)_4TX

11/04/2019

5240MHz_TX

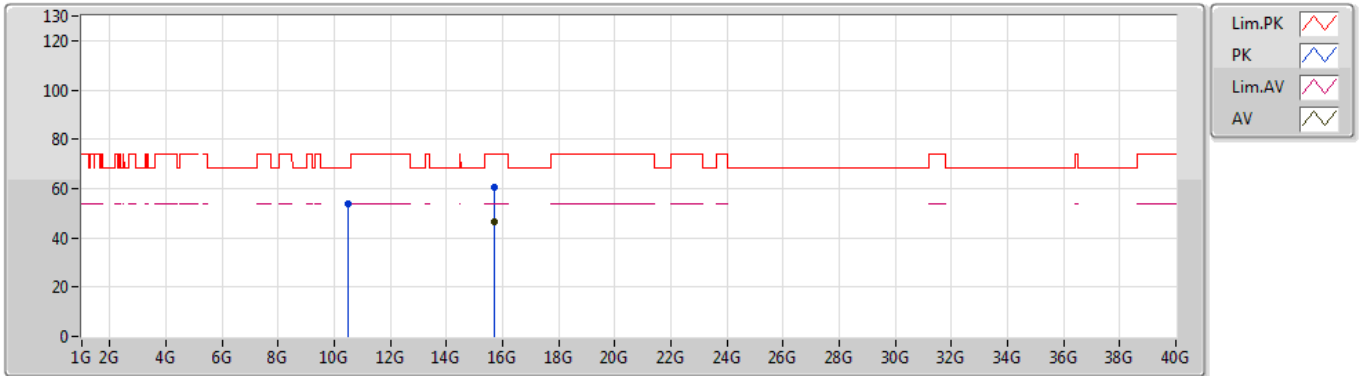

EUT Y_4TX
 Setting 25.5
 01-M-1
 Ant Dipole
 FSU(100015)

Type	Freq (Hz)	Level (dBuV/m)	Limit (dBuV/m)	Margin (dB)	Factor (dB)	Dist (m)	Condition	Azimuth (°)	Height (m)	Comment
PK	10.4811G	53.73	68.20	-14.47	11.02	3	Vertical	15	2.06	-
PK	15.71826G	60.34	74.00	-13.66	14.24	3	Vertical	16	1.43	-
AV	15.71746G	46.49	54.00	-7.51	14.24	3	Vertical	16	1.43	-

802.11a_Nss1,(6Mbps)_4TX

11/04/2019

5240MHz_TX

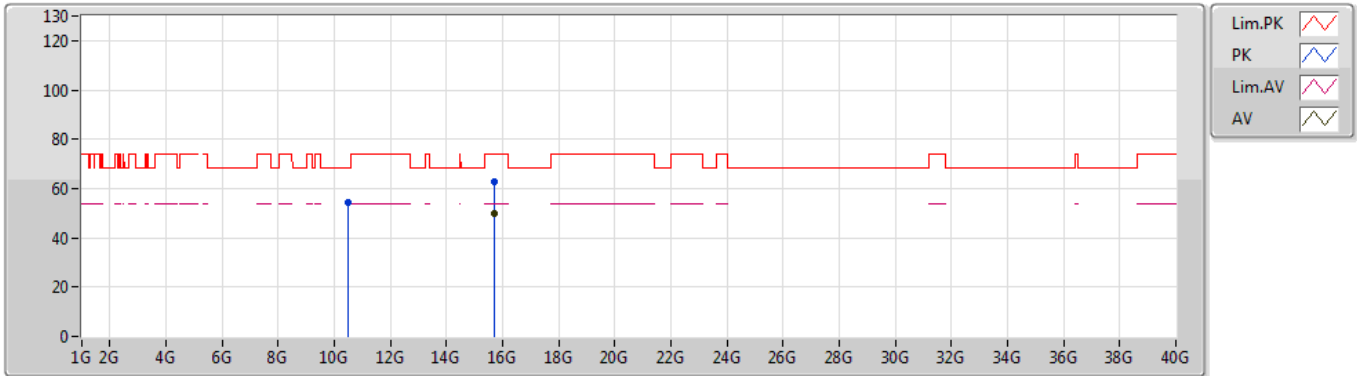

EUT Y_4TX
 Setting 25.5
 01-M-1
 Ant Dipole
 FSU(100015)

Type	Freq (Hz)	Level (dBuV/m)	Limit (dBuV/m)	Margin (dB)	Factor (dB)	Dist (m)	Condition	Azimuth (°)	Height (m)	Comment
PK	10.4726G	54.30	68.20	-13.90	11.00	3	Horizontal	332	2.47	-
PK	15.7242G	62.61	74.00	-11.39	14.23	3	Horizontal	294	2.59	-
AV	15.7226G	49.84	54.00	-4.16	14.24	3	Horizontal	294	2.59	-

802.11a_Nss1,(6Mbps)_4TX

11/04/2019

5745MHz_TX

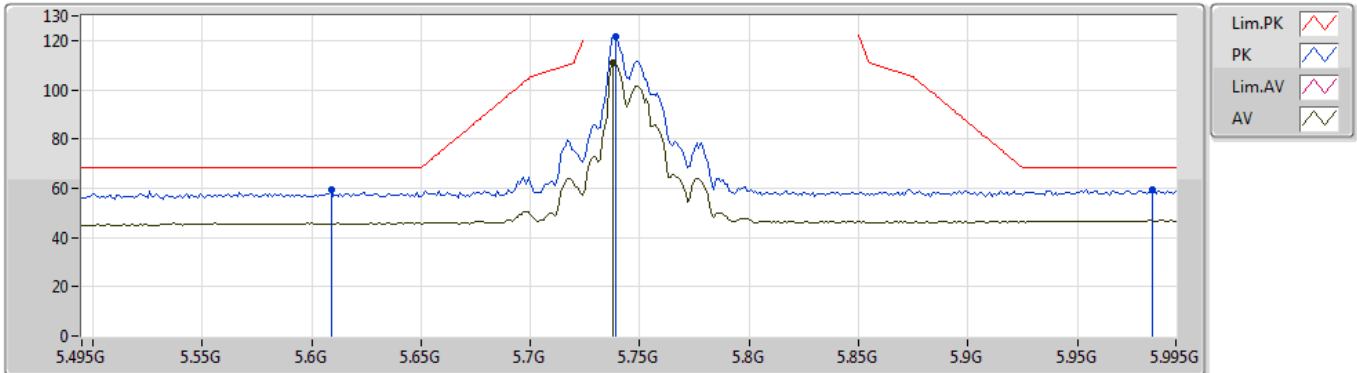

EUT Y_4TX
 Setting 21.5
 01-M-1-10
 Ant Dipole
 FSU(100015)

Type	Freq (Hz)	Level (dBuV/m)	Limit (dBuV/m)	Margin (dB)	Factor (dB)	Dist (m)	Condition	Azimuth (°)	Height (m)	Comment
PK	5.609G	59.14	68.20	-9.06	5.65	3	Vertical	71	1.47	-
PK	5.739G	121.55	Inf	-Inf	5.83	3	Vertical	71	1.47	-
AV	5.738G	111.22	Inf	-Inf	5.83	3	Vertical	71	1.47	-
PK	5.984G	59.66	68.20	-8.54	7.07	3	Vertical	71	1.47	-

802.11a_Nss1,(6Mbps)_4TX

11/04/2019

5745MHz_TX

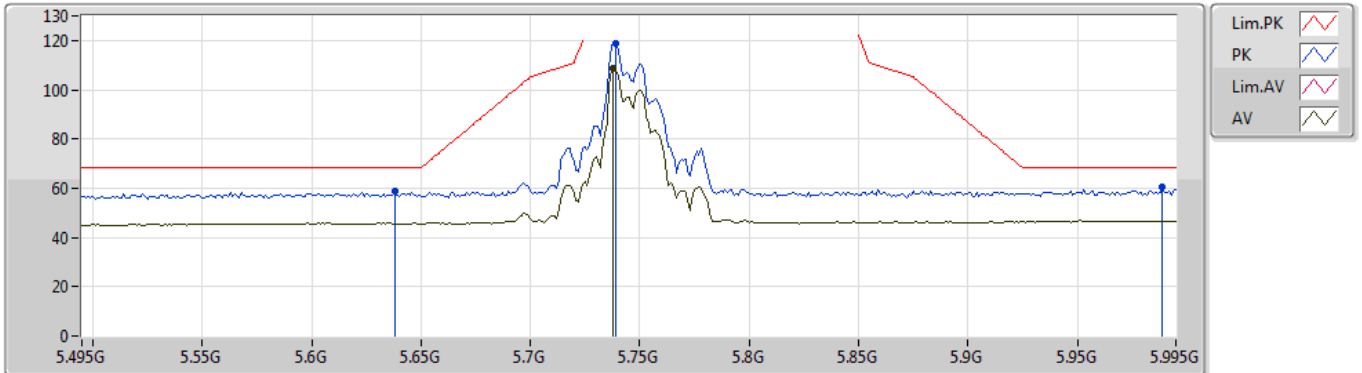

EUT Y_4TX
 Setting 21.5
 01-M-1-10
 Ant Dipole
 FSU(100015)

Type	Freq (Hz)	Level (dBuV/m)	Limit (dBuV/m)	Margin (dB)	Factor (dB)	Dist (m)	Condition	Azimuth (°)	Height (m)	Comment
PK	5.638G	59.11	68.20	-9.09	5.68	3	Horizontal	2	1.49	-
PK	5.739G	119.03	Inf	-Inf	5.83	3	Horizontal	2	1.49	-
AV	5.738G	108.80	Inf	-Inf	5.83	3	Horizontal	2	1.49	-
PK	5.989G	60.40	68.20	-7.80	7.10	3	Horizontal	2	1.49	-

802.11a_Nss1,(6Mbps)_4TX

11/04/2019

5745MHz_TX

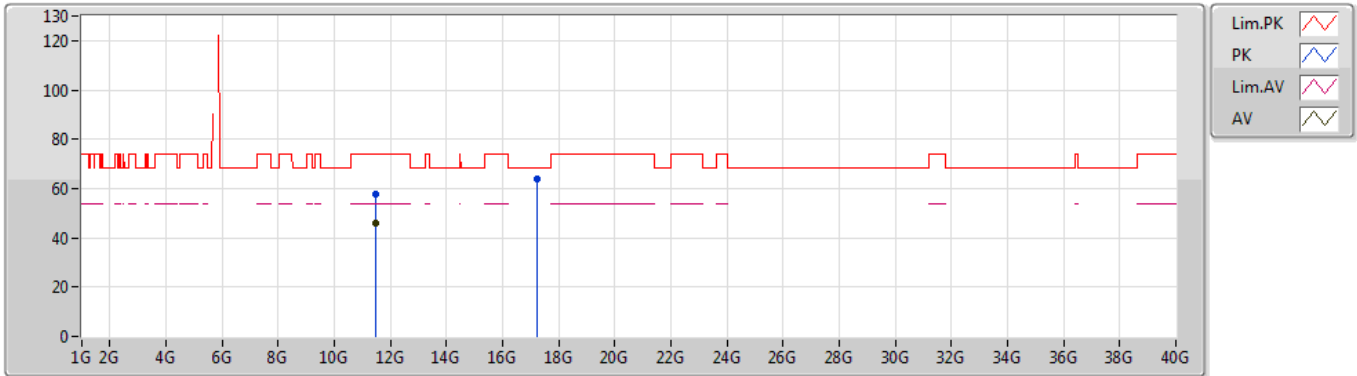

EUT_Y_4TX
 Setting 21.5
 01-M-1
 Ant Dipole
 FSU(100015)

Type	Freq (Hz)	Level (dBuV/m)	Limit (dBuV/m)	Margin (dB)	Factor (dB)	Dist (m)	Condition	Azimuth (°)	Height (m)	Comment
PK	11.49089G	57.93	74.00	-16.07	11.93	3	Vertical	152	1.27	-
AV	11.4881G	46.17	54.00	-7.83	11.93	3	Vertical	152	1.27	-
PK	17.232G	64.11	68.20	-4.09	18.04	3	Vertical	350	1.38	-

802.11a_Nss1,(6Mbps)_4TX

11/04/2019

5745MHz_TX

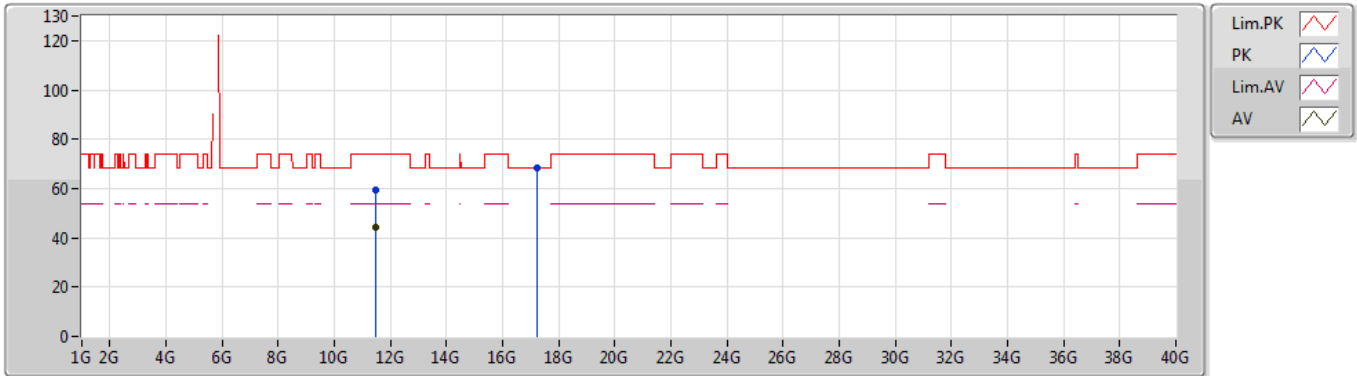

EUT_Y_4TX
 Setting 21.5
 01-M-1
 Ant Dipole
 FSU(100015)

Type	Freq (Hz)	Level (dBuV/m)	Limit (dBuV/m)	Margin (dB)	Factor (dB)	Dist (m)	Condition	Azimuth (°)	Height (m)	Comment
PK	11.49128G	59.16	74.00	-14.84	11.93	3	Horizontal	222	2.06	-
AV	11.488G	44.09	54.00	-9.91	11.93	3	Horizontal	222	2.06	-
PK	17.226G	68.11	68.20	-0.09	18.03	3	Horizontal	308	1.50	-

802.11a_Nss1,(6Mbps)_4TX

11/04/2019

5785MHz_TX

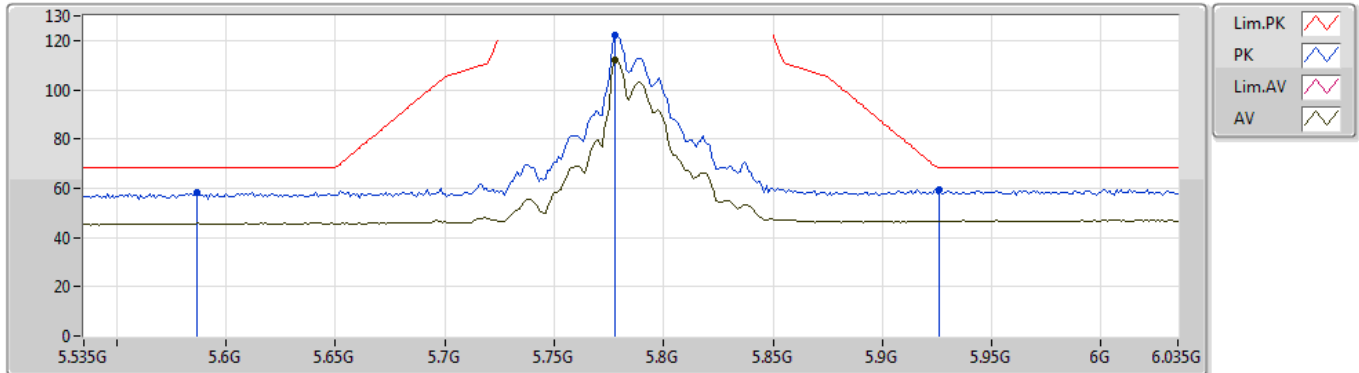

EUT Y_4TX
 Setting 22.5
 01-M-1-10
 Ant Dipole
 FSU(100015)

Type	Freq (Hz)	Level (dBuV/m)	Limit (dBuV/m)	Margin (dB)	Factor (dB)	Dist (m)	Condition	Azimuth (°)	Height (m)	Comment
PK	5.587G	58.52	68.20	-9.68	5.60	3	Vertical	70	1.46	-
PK	5.778G	122.08	Inf	-Inf	5.91	3	Vertical	70	1.46	-
AV	5.778G	111.89	Inf	-Inf	5.91	3	Vertical	70	1.46	-
PK	5.926G	59.60	68.20	-8.60	6.81	3	Vertical	70	1.46	-

802.11a_Nss1,(6Mbps)_4TX

11/04/2019

5785MHz_TX

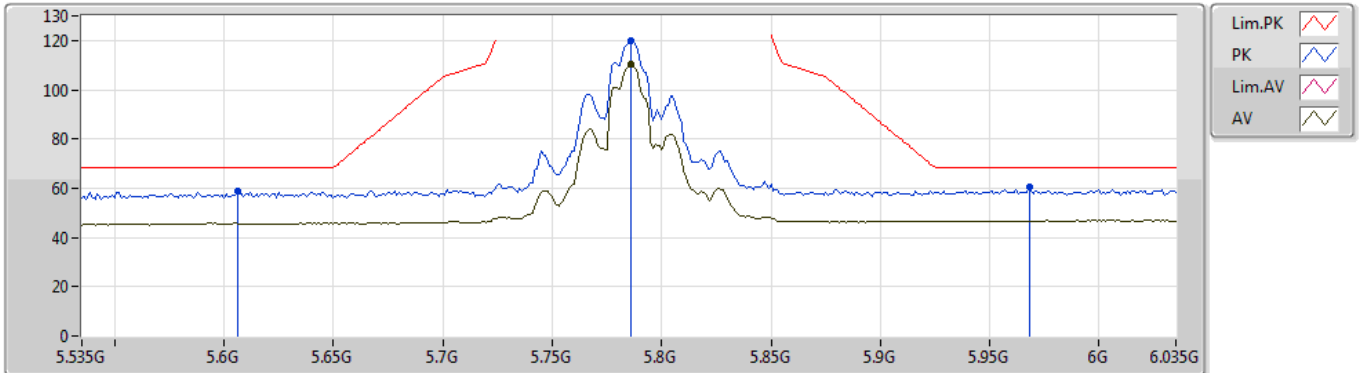

EUT Y_4TX
 Setting 22.5
 01-M-1-10
 Ant Dipole
 FSU(100015)

Type	Freq (Hz)	Level (dBuV/m)	Limit (dBuV/m)	Margin (dB)	Factor (dB)	Dist (m)	Condition	Azimuth (°)	Height (m)	Comment
PK	5.606G	58.61	68.20	-9.59	5.65	3	Horizontal	180	1.95	-
PK	5.786G	120.03	Inf	-Inf	5.92	3	Horizontal	180	1.95	-
AV	5.786G	110.47	Inf	-Inf	5.92	3	Horizontal	180	1.95	-
PK	5.968G	60.24	68.20	-7.96	7.01	3	Horizontal	180	1.95	-

802.11a_Nss1,(6Mbps)_4TX

11/04/2019

5785MHz_TX

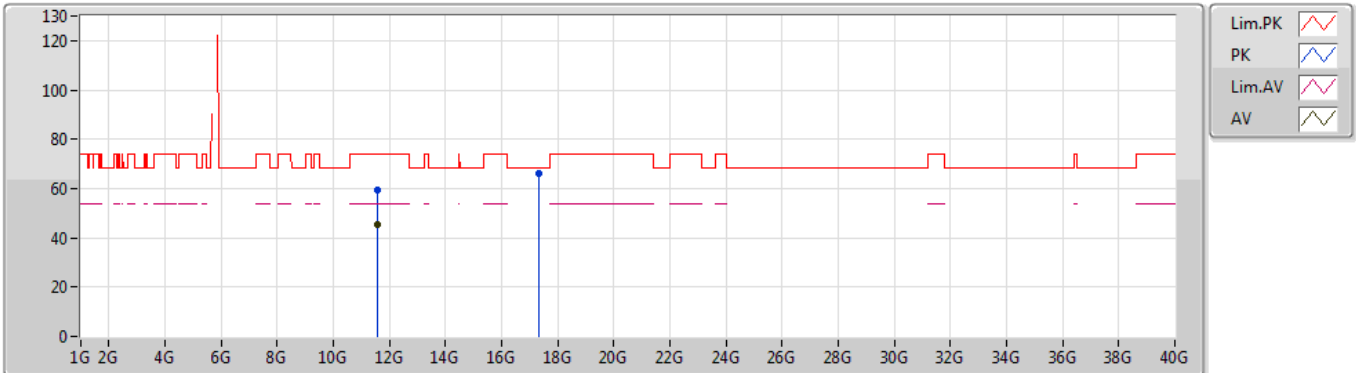

EUT Y_4TX
 Setting 22.5
 01-M-1
 Ant Dipole
 FSU(100015)

Type	Freq (Hz)	Level (dBuV/m)	Limit (dBuV/m)	Margin (dB)	Factor (dB)	Dist (m)	Condition	Azimuth (°)	Height (m)	Comment
PK	11.575G	59.36	74.00	-14.64	11.95	3	Vertical	2	1.30	-
AV	11.5761G	45.31	54.00	-8.69	11.96	3	Vertical	2	1.30	-
PK	17.34996G	66.04	68.20	-2.16	18.25	3	Vertical	332	2.39	-

802.11a_Nss1,(6Mbps)_4TX

11/04/2019

5785MHz_TX

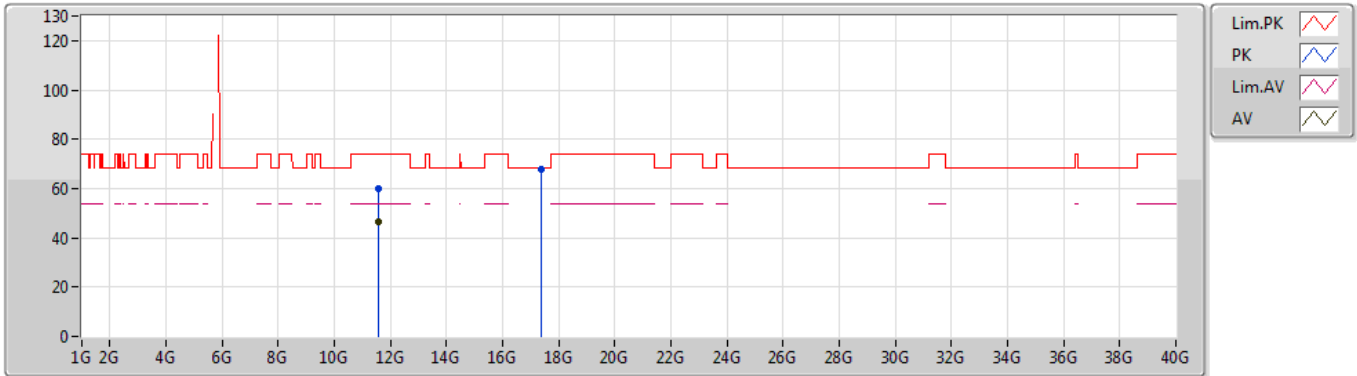

EUT Y_4TX
 Setting 22.5
 01-M-1
 Ant Dipole
 FSU(100015)

Type	Freq (Hz)	Level (dBuV/m)	Limit (dBuV/m)	Margin (dB)	Factor (dB)	Dist (m)	Condition	Azimuth (°)	Height (m)	Comment
PK	11.5749G	59.73	74.00	-14.27	11.95	3	Horizontal	337	1.28	-
AV	11.576G	46.53	54.00	-7.47	11.96	3	Horizontal	337	1.28	-
PK	17.36136G	67.98	68.20	-0.22	18.27	3	Horizontal	311	2.46	-

802.11a_Nss1,(6Mbps)_4TX

11/04/2019

5825MHz_TX

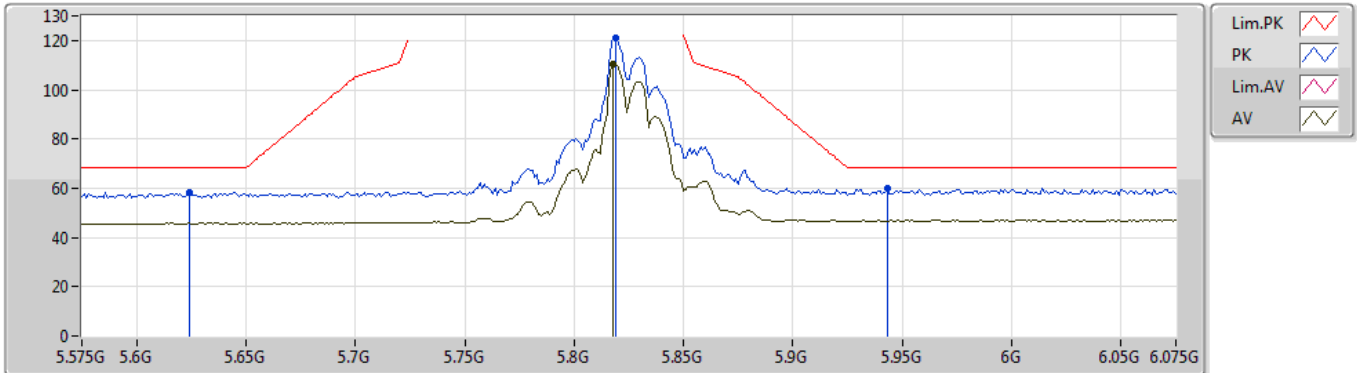

EUT_Y_4TX
Setting 22
01-M-1-10
Ant Dipole
FSU(100015)

Type	Freq (Hz)	Level (dBuV/m)	Limit (dBuV/m)	Margin (dB)	Factor (dB)	Dist (m)	Condition	Azimuth (°)	Height (m)	Comment
PK	5.624G	58.32	68.20	-9.88	5.66	3	Vertical	67	1.50	-
PK	5.819G	120.91	Inf	-Inf	6.09	3	Vertical	67	1.50	-
AV	5.818G	110.33	Inf	-Inf	6.09	3	Vertical	67	1.50	-
PK	5.943G	59.84	68.20	-8.36	6.89	3	Vertical	67	1.50	-

802.11a_Nss1,(6Mbps)_4TX

11/04/2019

5825MHz_TX

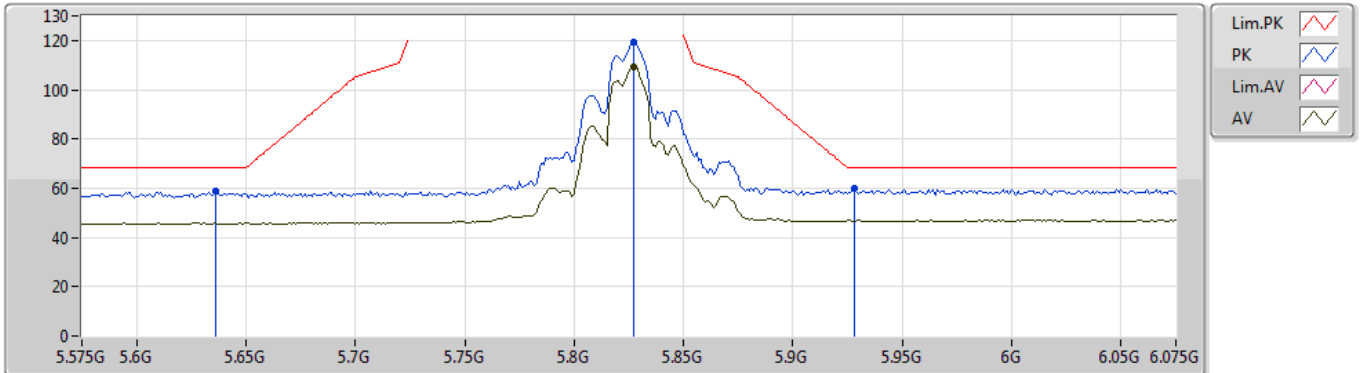

EUT Y_4TX
 Setting 22
 01-M-1-10
 Ant Dipole
 FSU(100015)

Type	Freq (Hz)	Level (dBuV/m)	Limit (dBuV/m)	Margin (dB)	Factor (dB)	Dist (m)	Condition	Azimuth (°)	Height (m)	Comment
PK	5.636G	58.98	68.20	-9.22	5.68	3	Horizontal	180	2.07	-
PK	5.827G	119.47	Inf	-Inf	6.16	3	Horizontal	180	2.07	-
AV	5.827G	109.15	Inf	-Inf	6.16	3	Horizontal	180	2.07	-
PK	5.928G	60.13	68.20	-8.07	6.82	3	Horizontal	180	2.07	-

802.11a_Nss1,(6Mbps)_4TX

11/04/2019

5825MHz_TX

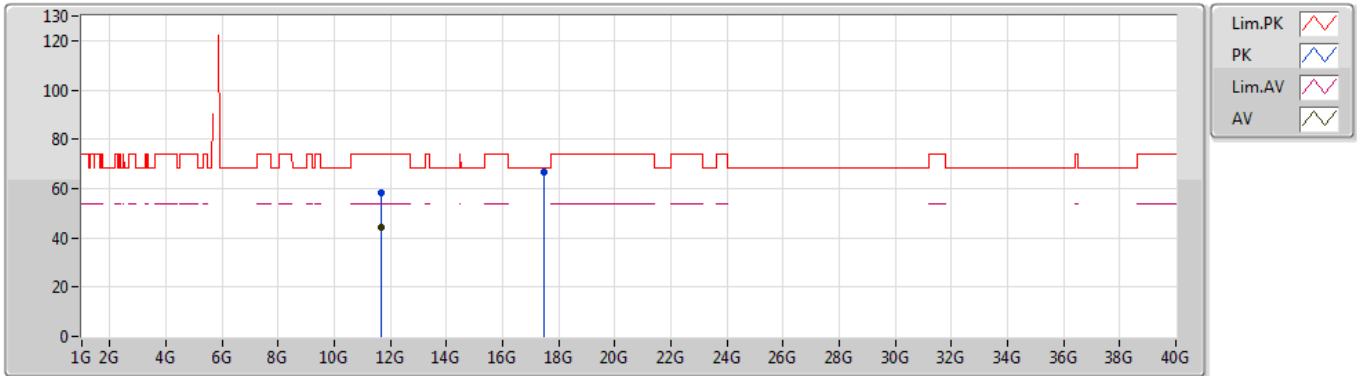

EUT Y_4TX
 Setting 22
 01-M-1
 Ant Dipole
 FSU(100015)

Type	Freq (Hz)	Level (dBuV/m)	Limit (dBuV/m)	Margin (dB)	Factor (dB)	Dist (m)	Condition	Azimuth (°)	Height (m)	Comment
PK	11.64954G	58.20	74.00	-15.80	11.99	3	Vertical	265	2.16	-
AV	11.64991G	44.26	54.00	-9.74	11.99	3	Vertical	265	2.16	-
PK	17.466G	66.41	68.20	-1.79	18.46	3	Vertical	344	2.41	-

802.11a_Nss1,(6Mbps)_4TX

11/04/2019

5825MHz_TX

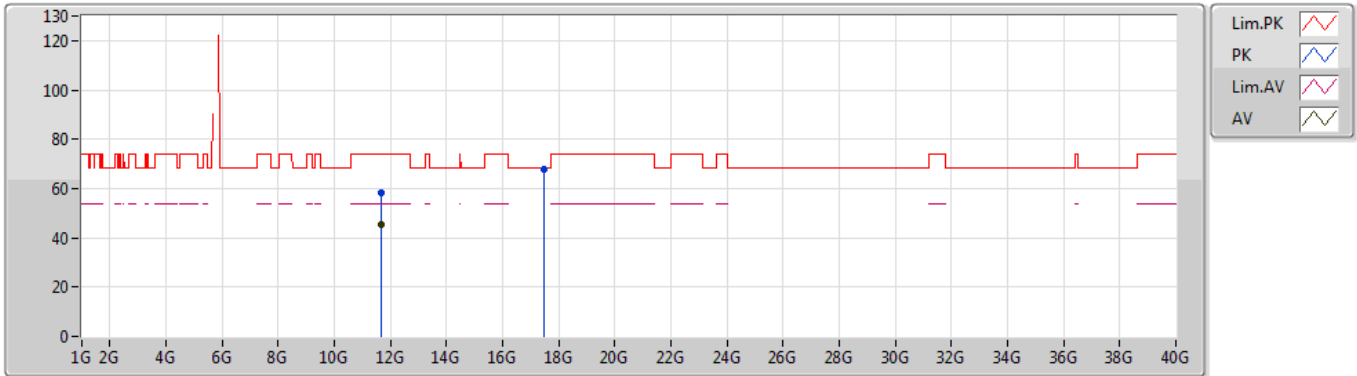

EUT Y_4TX
 Setting 22
 01-M-1
 Ant Dipole
 FSU(100015)

Type	Freq (Hz)	Level (dBuV/m)	Limit (dBuV/m)	Margin (dB)	Factor (dB)	Dist (m)	Condition	Azimuth (°)	Height (m)	Comment
PK	11.64928G	58.00	74.00	-16.00	11.99	3	Horizontal	244	2.10	-
AV	11.64932G	45.41	54.00	-8.59	11.99	3	Horizontal	244	2.10	-
PK	17.47296G	67.95	68.20	-0.25	18.47	3	Horizontal	310	1.88	-

802.11ac VHT20_Nss1,(MCS0)_4TX

11/04/2019

5180MHz_TX

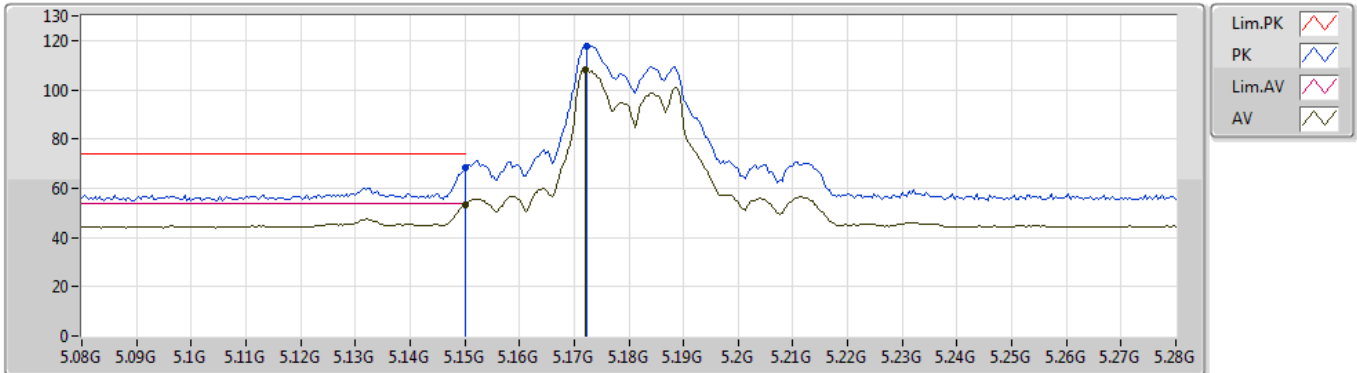

EUT Y_4TX
 Setting 20.5
 01-M-1-10
 Ant Dipole
 FSU(100015)

Type	Freq (Hz)	Level (dBuV/m)	Limit (dBuV/m)	Margin (dB)	Factor (dB)	Dist (m)	Condition	Azimuth (°)	Height (m)	Comment
PK	5.15G	68.19	74.00	-5.81	4.25	3	Vertical	64	1.61	-
AV	5.15G	53.24	54.00	-0.76	4.25	3	Vertical	64	1.61	-
PK	5.1724G	117.91	Inf	-Inf	4.25	3	Vertical	64	1.61	-
AV	5.172G	108.16	Inf	-Inf	4.25	3	Vertical	64	1.61	-

802.11ac VHT20_Nss1,(MCS0)_4TX

11/04/2019

5180MHz_TX

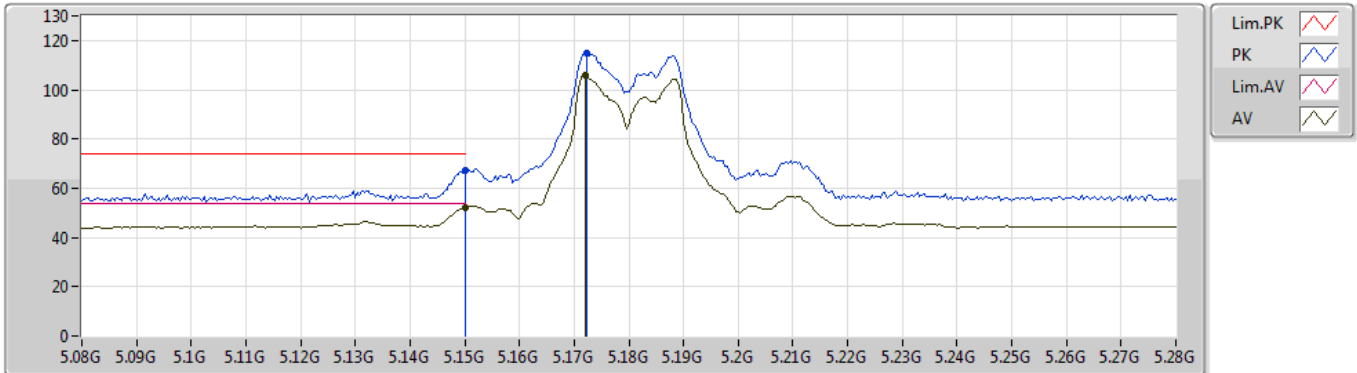

EUT Y_4TX
 Setting 20.5
 01-M-1-10
 Ant Dipole
 FSU(100015)

Type	Freq (Hz)	Level (dBuV/m)	Limit (dBuV/m)	Margin (dB)	Factor (dB)	Dist (m)	Condition	Azimuth (°)	Height (m)	Comment
PK	5.15G	67.31	74.00	-6.69	4.25	3	Horizontal	183	1.41	-
AV	5.15G	52.21	54.00	-1.79	4.25	3	Horizontal	183	1.41	-
PK	5.1724G	114.88	Inf	-Inf	4.25	3	Horizontal	183	1.41	-
AV	5.172G	105.68	Inf	-Inf	4.25	3	Horizontal	183	1.41	-

802.11ac VHT20_Nss1,(MCS0)_4TX

11/04/2019

5180MHz_TX

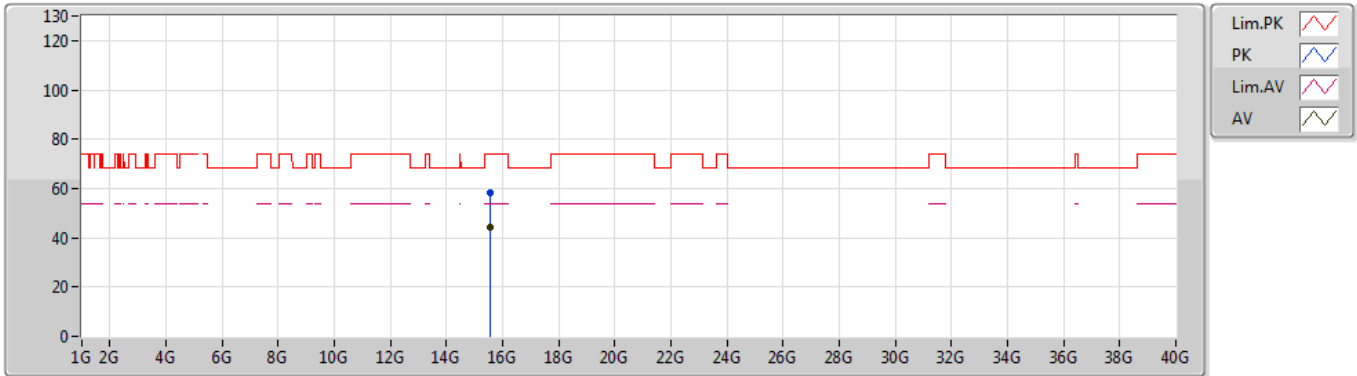

EUT Y_4TX
 Setting 20.5
 01-M-1
 Ant Dipole
 FSU(100015)

Type	Freq (Hz)	Level (dBuV/m)	Limit (dBuV/m)	Margin (dB)	Factor (dB)	Dist (m)	Condition	Azimuth (°)	Height (m)	Comment
PK	15.53974G	58.26	74.00	-15.74	14.46	3	Vertical	187	1.51	-
AV	15.54158G	44.54	54.00	-9.46	14.46	3	Vertical	187	1.51	-

802.11ac VHT20_Nss1,(MCS0)_4TX

11/04/2019

5180MHz_TX

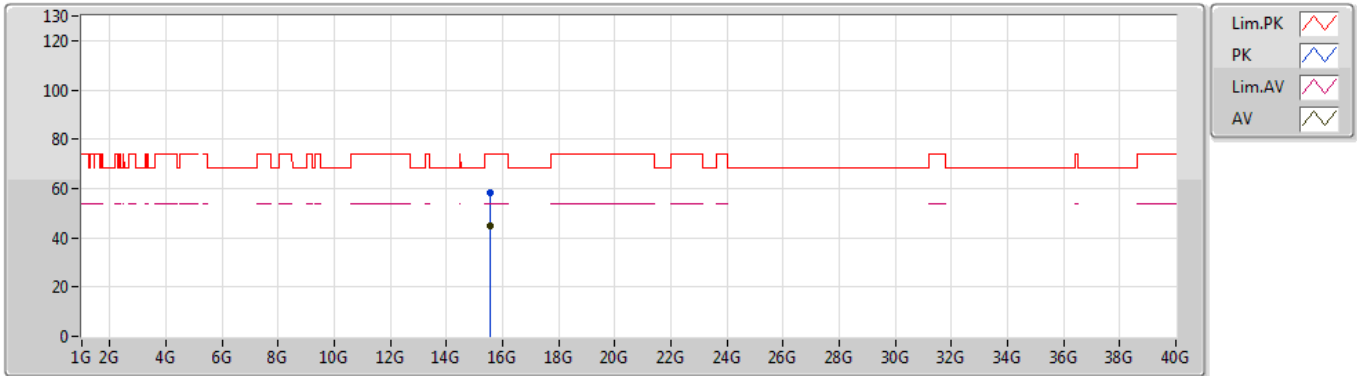

EUT Y_4TX
 Setting 20.5
 01-M-1
 Ant Dipole
 FSU(100015)

Type	Freq (Hz)	Level (dBuV/m)	Limit (dBuV/m)	Margin (dB)	Factor (dB)	Dist (m)	Condition	Azimuth (°)	Height (m)	Comment
PK	15.54108G	58.20	74.00	-15.80	14.46	3	Horizontal	86	2.11	-
AV	15.5413G	44.91	54.00	-9.09	14.46	3	Horizontal	86	2.11	-

802.11ac VHT20_Nss1,(MCS0)_4TX

11/04/2019

5200MHz_TX

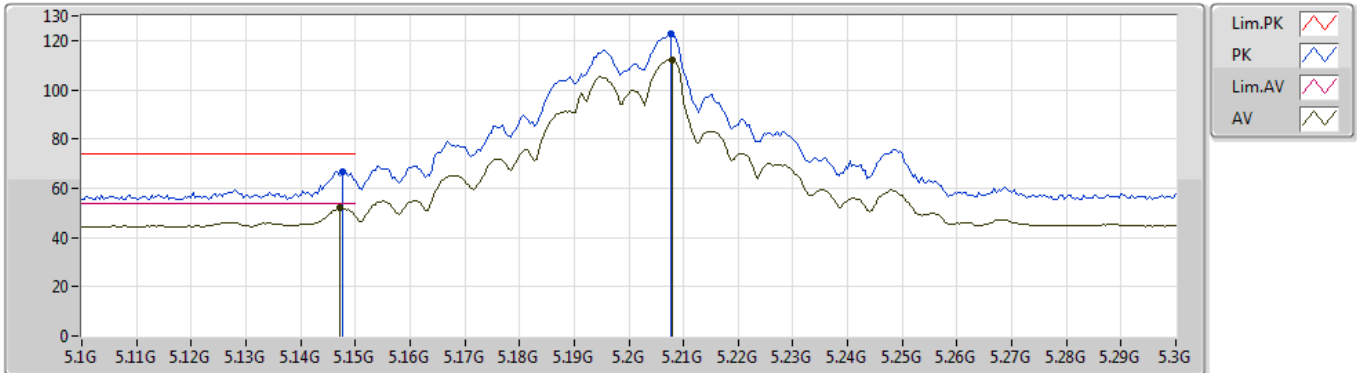

EUT Y_4TX
 Setting 24
 01-M-1-10
 Ant Dipole
 FSU(100015)

Type	Freq (Hz)	Level (dBuV/m)	Limit (dBuV/m)	Margin (dB)	Factor (dB)	Dist (m)	Condition	Azimuth (°)	Height (m)	Comment
PK	5.1476G	66.80	74.00	-7.20	4.25	3	Vertical	64	2.26	-
AV	5.1472G	52.00	54.00	-2.00	4.25	3	Vertical	64	2.26	-
PK	5.2076G	122.49	Inf	-Inf	4.30	3	Vertical	64	2.26	-
AV	5.208G	112.05	Inf	-Inf	4.30	3	Vertical	64	2.26	-

802.11ac VHT20_Nss1,(MCS0)_4TX

11/04/2019

5200MHz_TX

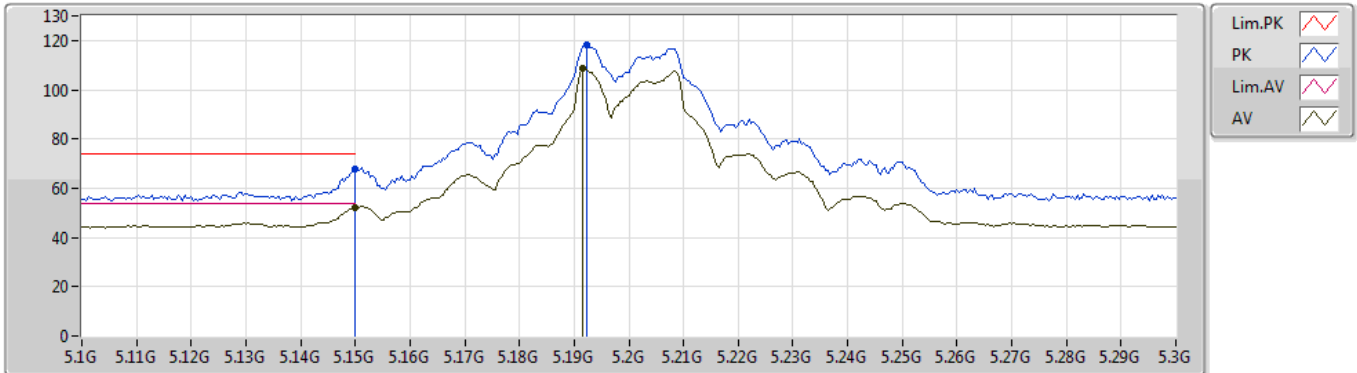

EUT Y_4TX
 Setting 24
 01-M-1-10
 Ant Dipole
 FSU(100015)

Type	Freq (Hz)	Level (dBuV/m)	Limit (dBuV/m)	Margin (dB)	Factor (dB)	Dist (m)	Condition	Azimuth (°)	Height (m)	Comment
PK	5.15G	67.53	74.00	-6.47	4.25	3	Horizontal	182	1.46	-
AV	5.15G	51.98	54.00	-2.02	4.25	3	Horizontal	182	1.46	-
PK	5.1924G	118.49	Inf	-Inf	4.26	3	Horizontal	182	1.46	-
AV	5.1916G	108.71	Inf	-Inf	4.26	3	Horizontal	182	1.46	-

802.11ac VHT20_Nss1,(MCS0)_4TX

11/04/2019

5200MHz_TX

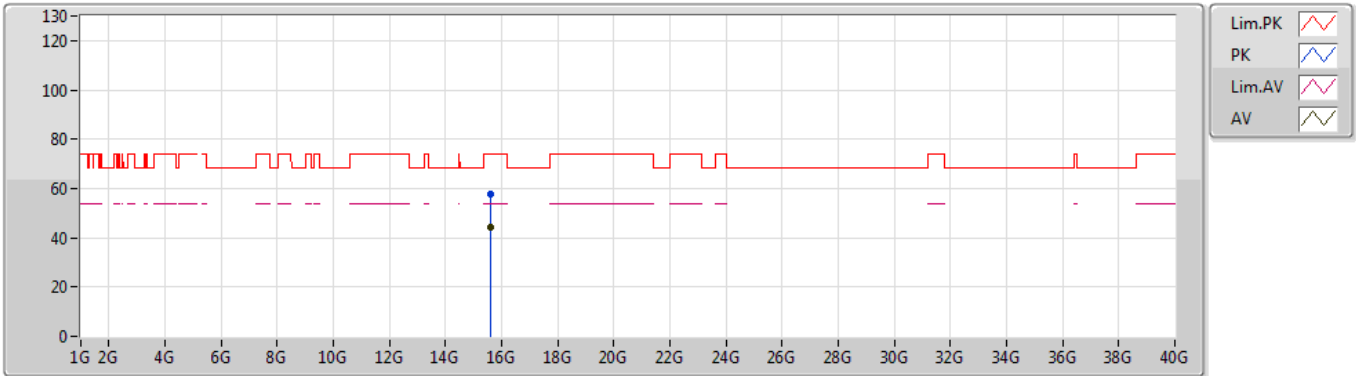

EUT Y_4TX
 Setting 24
 01-M-1
 Ant Dipole
 FSU(100015)

Type	Freq (Hz)	Level (dBuV/m)	Limit (dBuV/m)	Margin (dB)	Factor (dB)	Dist (m)	Condition	Azimuth (°)	Height (m)	Comment
PK	15.59972G	57.56	74.00	-16.44	14.39	3	Vertical	32	2.37	-
AV	15.59854G	44.46	54.00	-9.54	14.39	3	Vertical	32	2.37	-

802.11ac VHT20_Nss1,(MCS0)_4TX

11/04/2019

5200MHz_TX

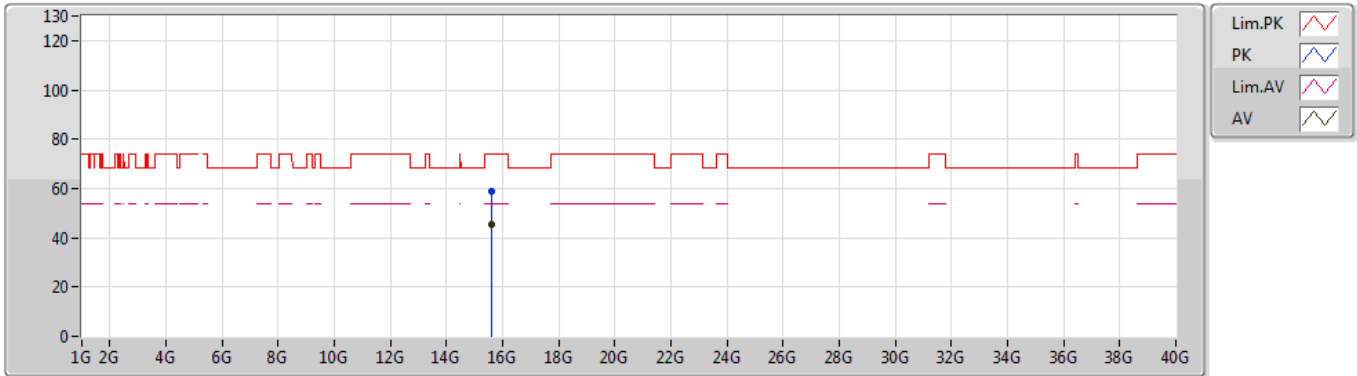

EUT Y_4TX
 Setting 24
 01-M-1
 Ant Dipole
 FSU(100015)

Type	Freq (Hz)	Level (dBuV/m)	Limit (dBuV/m)	Margin (dB)	Factor (dB)	Dist (m)	Condition	Azimuth (°)	Height (m)	Comment
PK	15.60068G	58.64	74.00	-15.36	14.39	3	Horizontal	297	2.34	-
AV	15.6025G	45.46	54.00	-8.54	14.38	3	Horizontal	297	2.34	-

802.11ac VHT20_Nss1,(MCS0)_4TX

11/04/2019

5240MHz_TX

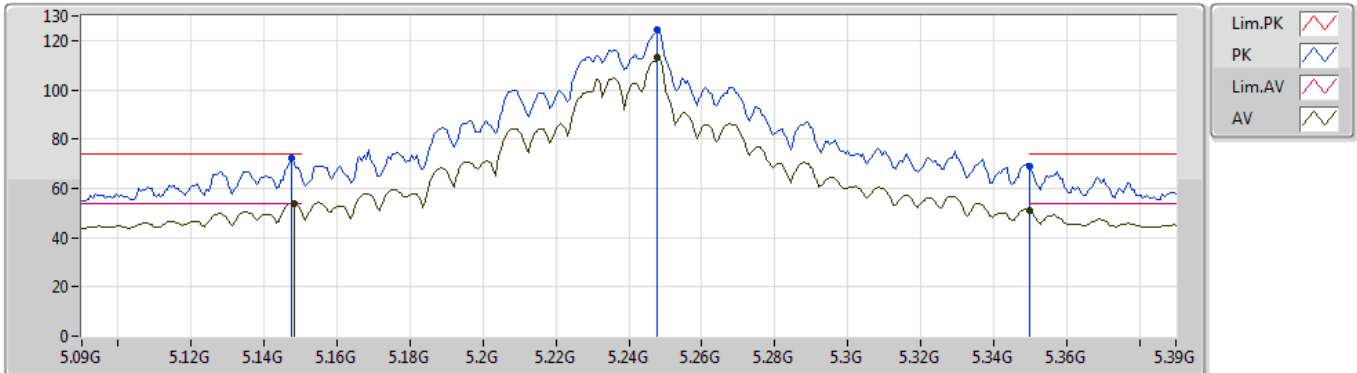

EUT_Y_4TX
 Setting 25.5
 01-M-1-10
 Ant Dipole
 FSU(100015)

Type	Freq (Hz)	Level (dBuV/m)	Limit (dBuV/m)	Margin (dB)	Factor (dB)	Dist (m)	Condition	Azimuth (°)	Height (m)	Comment
PK	5.1476G	72.15	74.00	-1.85	4.25	3	Vertical	64	2.26	-
AV	5.1482G	53.93	54.00	-0.07	4.25	3	Vertical	64	2.26	-
PK	5.2478G	124.47	Inf	-Inf	4.44	3	Vertical	64	2.26	-
AV	5.2478G	112.91	Inf	-Inf	4.44	3	Vertical	64	2.26	-
PK	5.355G	69.09	74.00	-4.91	4.81	3	Vertical	64	2.26	-
AV	5.355G	51.02	54.00	-2.98	4.81	3	Vertical	64	2.26	-

802.11ac VHT20_Nss1,(MCS0)_4TX

11/04/2019

5240MHz_TX

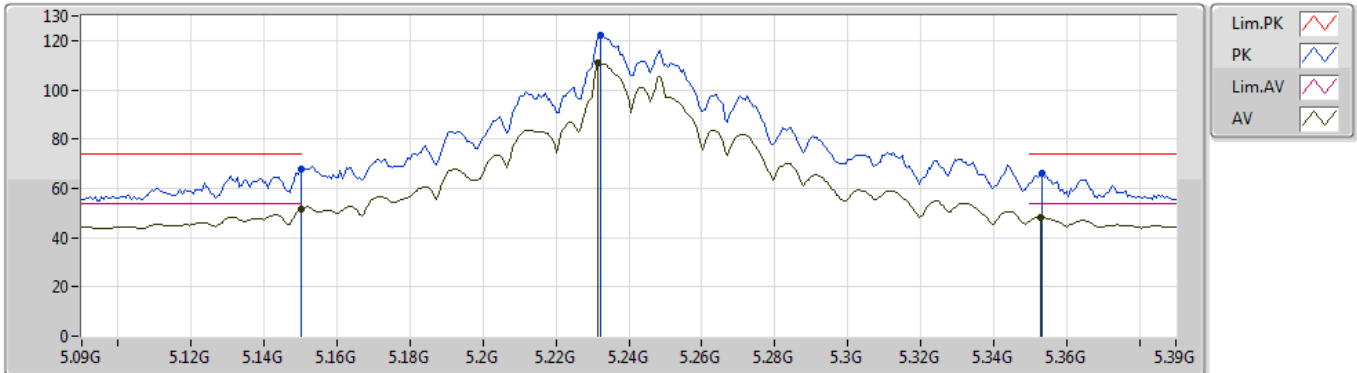

EUT_Y_4TX
 Setting 25.5
 01-M-1-10
 Ant Dipole
 FSU(100015)

Type	Freq (Hz)	Level (dBuV/m)	Limit (dBuV/m)	Margin (dB)	Factor (dB)	Dist (m)	Condition	Azimuth (°)	Height (m)	Comment
PK	5.15G	68.04	74.00	-5.96	4.25	3	Horizontal	184	1.47	-
AV	5.15G	51.80	54.00	-2.20	4.25	3	Horizontal	184	1.47	-
PK	5.2322G	122.25	Inf	-Inf	4.39	3	Horizontal	184	1.47	-
AV	5.2316G	110.77	Inf	-Inf	4.38	3	Horizontal	184	1.47	-
PK	5.3534G	66.09	74.00	-7.91	4.82	3	Horizontal	184	1.47	-
AV	5.3528G	48.40	54.00	-5.60	4.82	3	Horizontal	184	1.47	-

802.11ac VHT20_Nss1,(MCS0)_4TX

11/04/2019

5240MHz_TX

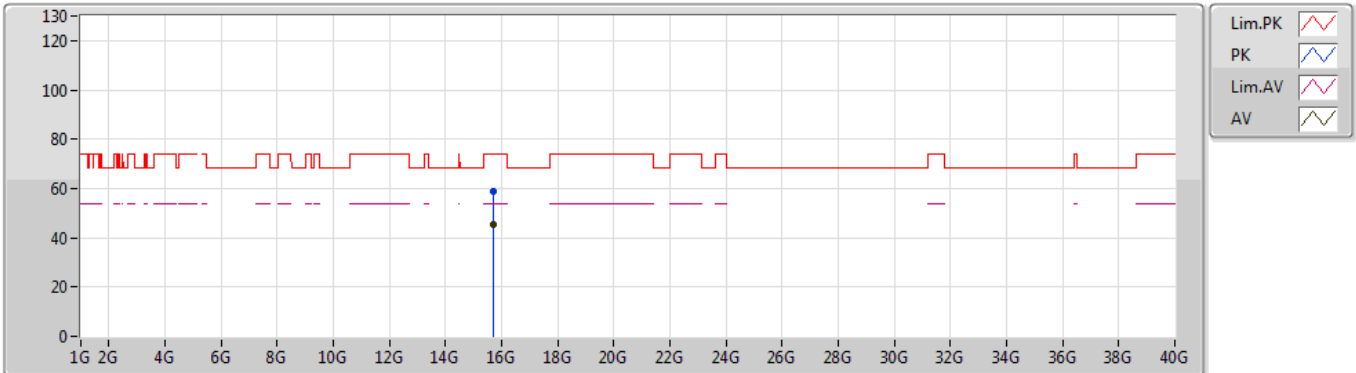

EUT Y_4TX
 Setting 25.5
 01-M-1
 Ant Dipole
 FSU(100015)

Type	Freq (Hz)	Level (dBuV/m)	Limit (dBuV/m)	Margin (dB)	Factor (dB)	Dist (m)	Condition	Azimuth (°)	Height (m)	Comment
PK	15.7159G	58.77	74.00	-15.23	14.24	3	Vertical	148	2.08	-
AV	15.7154G	45.15	54.00	-8.85	14.24	3	Vertical	148	2.08	-

802.11ac VHT20_Nss1,(MCS0)_4TX

11/04/2019

5240MHz_TX

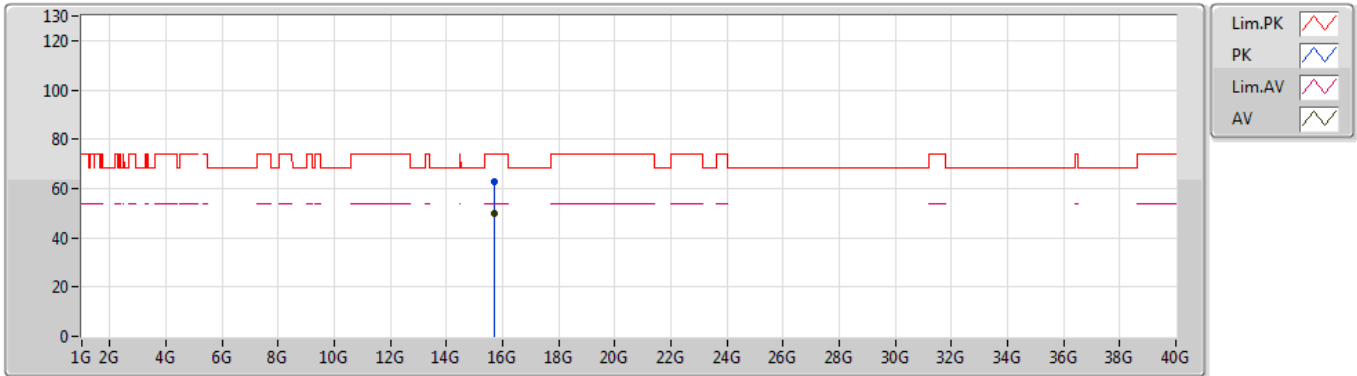

EUT Y_4TX
 Setting 25.5
 01-M-1
 Ant Dipole
 FSU(100015)

Type	Freq (Hz)	Level (dBuV/m)	Limit (dBuV/m)	Margin (dB)	Factor (dB)	Dist (m)	Condition	Azimuth (°)	Height (m)	Comment
PK	15.7242G	62.81	74.00	-11.19	14.23	3	Horizontal	304	1.85	-
AV	15.7234G	49.87	54.00	-4.13	14.24	3	Horizontal	304	1.85	-

802.11ac VHT20_Nss1,(MCS0)_4TX

11/04/2019

5745MHz_TX

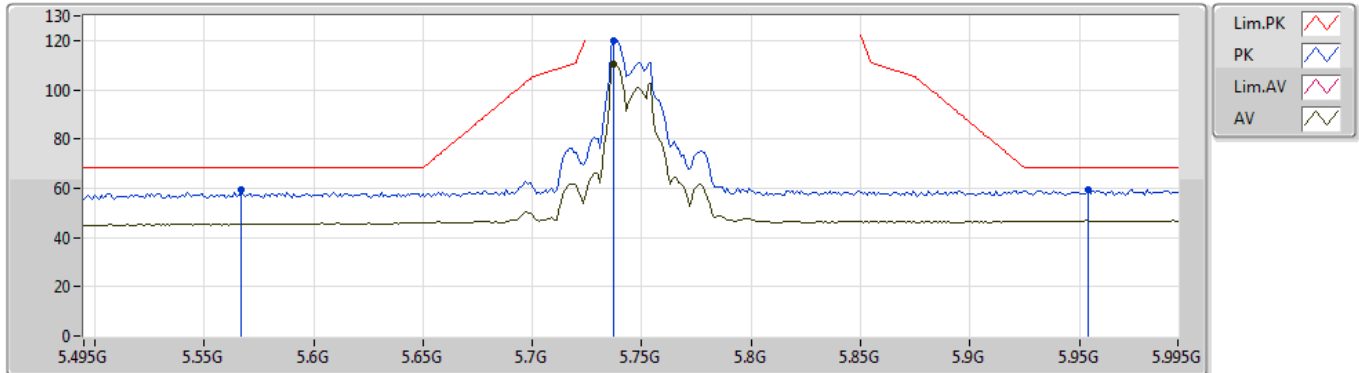

EUT Y_4TX
 Setting 21
 01-M-1-10
 Ant Dipole
 FSU(100015)

Type	Freq (Hz)	Level (dBuV/m)	Limit (dBuV/m)	Margin (dB)	Factor (dB)	Dist (m)	Condition	Azimuth (°)	Height (m)	Comment
PK	5.567G	59.61	68.20	-8.59	5.55	3	Vertical	73	1.46	-
PK	5.737G	120.07	Inf	-Inf	5.81	3	Vertical	73	1.46	-
AV	5.737G	110.19	Inf	-Inf	5.81	3	Vertical	73	1.46	-
PK	5.954G	59.67	68.20	-8.53	6.94	3	Vertical	73	1.46	-

802.11ac VHT20_Nss1,(MCS0)_4TX

11/04/2019

5745MHz_TX

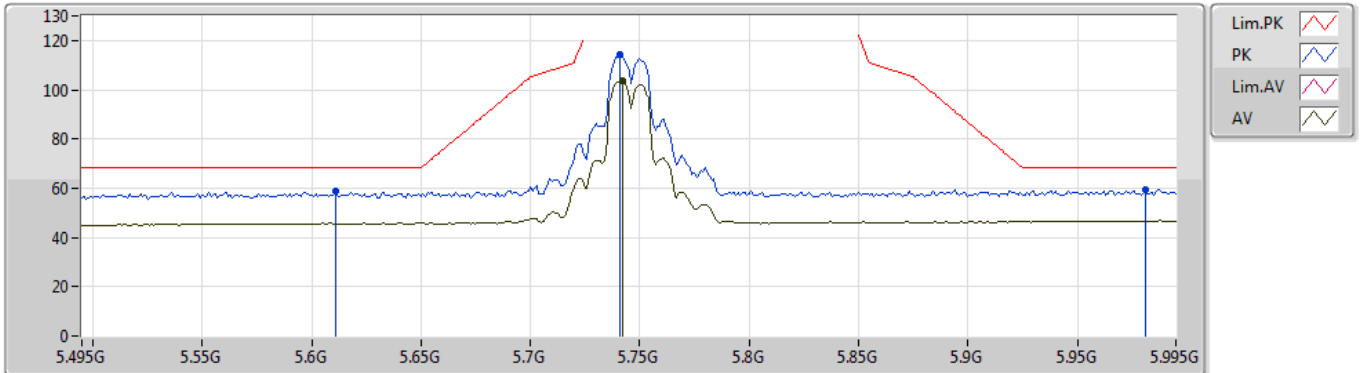

EUT Y_4TX
Setting 21
01-M-1-10
Ant Dipole
FSU(100015)

Type	Freq (Hz)	Level (dBuV/m)	Limit (dBuV/m)	Margin (dB)	Factor (dB)	Dist (m)	Condition	Azimuth (°)	Height (m)	Comment
PK	5.611G	58.77	68.20	-9.43	5.65	3	Horizontal	7	1.33	-
PK	5.741G	114.48	Inf	-Inf	5.83	3	Horizontal	7	1.33	-
AV	5.742G	103.90	Inf	-Inf	5.83	3	Horizontal	7	1.33	-
PK	5.981G	59.35	68.20	-8.85	7.06	3	Horizontal	7	1.33	-

802.11ac VHT20_Nss1,(MCS0)_4TX

11/04/2019

5745MHz_TX

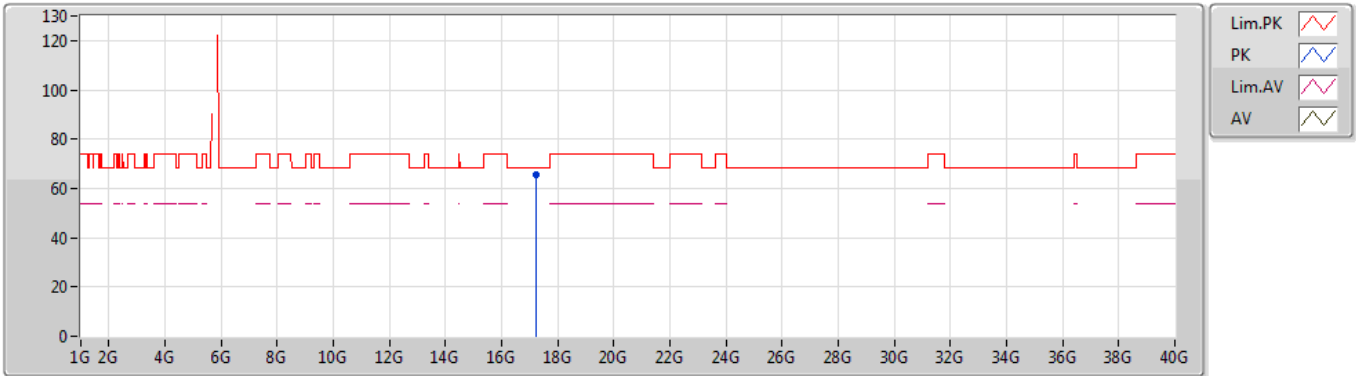

EUT Y_4TX
 Setting 21
 01-M-1
 Ant Dipole
 FSU(100015)

Type	Freq (Hz)	Level (dBuV/m)	Limit (dBuV/m)	Margin (dB)	Factor (dB)	Dist (m)	Condition	Azimuth (°)	Height (m)	Comment
PK	17.22336G	65.77	68.20	-2.43	18.03	3	Vertical	303	1.58	-

802.11ac VHT20_Nss1,(MCS0)_4TX

11/04/2019

5745MHz_TX

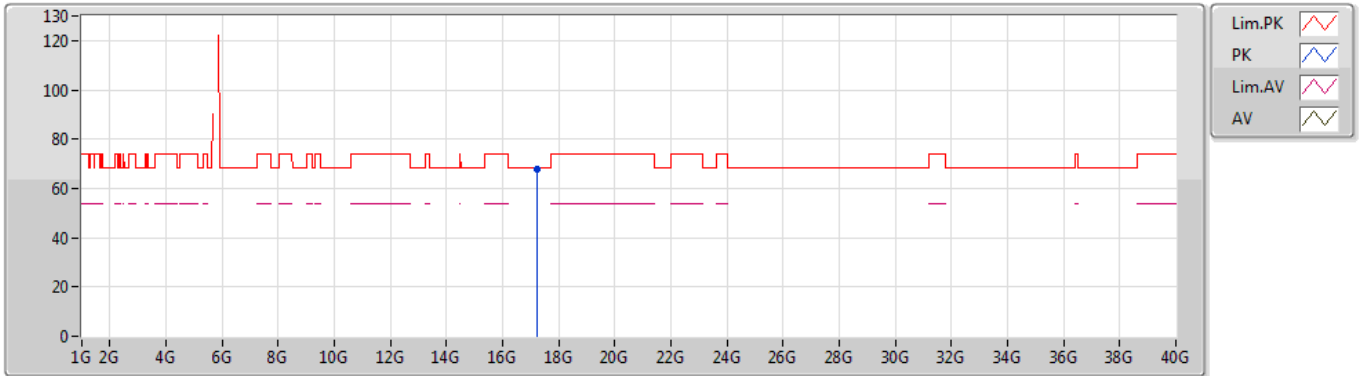

EUT Y_4TX
 Setting 21
 01-M-1
 Ant Dipole
 FSU(100015)

Type	Freq (Hz)	Level (dBuV/m)	Limit (dBuV/m)	Margin (dB)	Factor (dB)	Dist (m)	Condition	Azimuth (°)	Height (m)	Comment
PK	17.22432G	67.98	68.20	-0.22	18.03	3	Horizontal	311	1.50	-

802.11ac VHT20_Nss1,(MCS0)_4TX

11/04/2019

5785MHz_TX

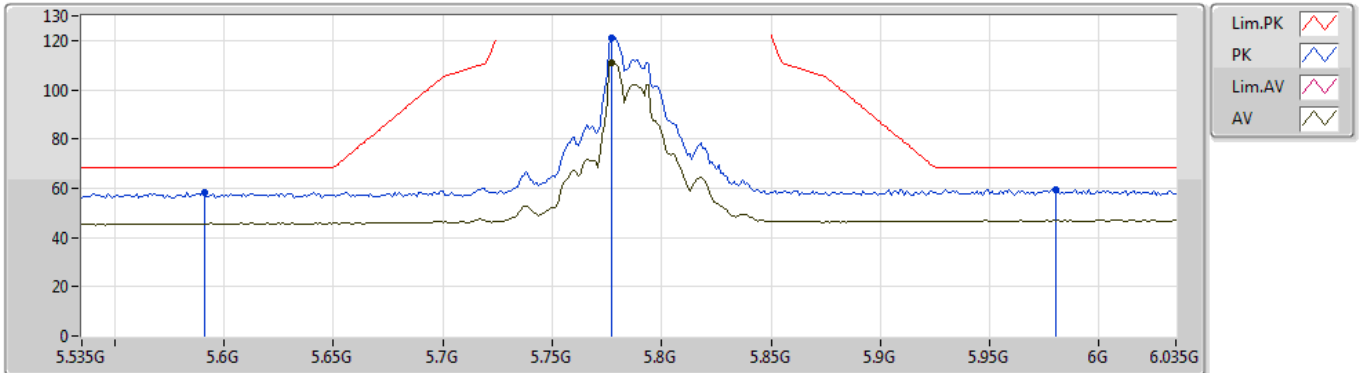

EUT Y_4TX
 Setting 22
 01-M-1-10
 Ant Dipole
 FSU(100015)

Type	Freq (Hz)	Level (dBuV/m)	Limit (dBuV/m)	Margin (dB)	Factor (dB)	Dist (m)	Condition	Azimuth (°)	Height (m)	Comment
PK	5.591G	58.52	68.20	-9.68	5.61	3	Vertical	71	1.47	-
PK	5.777G	121.07	Inf	-Inf	5.90	3	Vertical	71	1.47	-
AV	5.777G	110.92	Inf	-Inf	5.90	3	Vertical	71	1.47	-
PK	5.98G	59.47	68.20	-8.73	7.06	3	Vertical	71	1.47	-

802.11ac VHT20_Nss1,(MCS0)_4TX

11/04/2019

5785MHz_TX

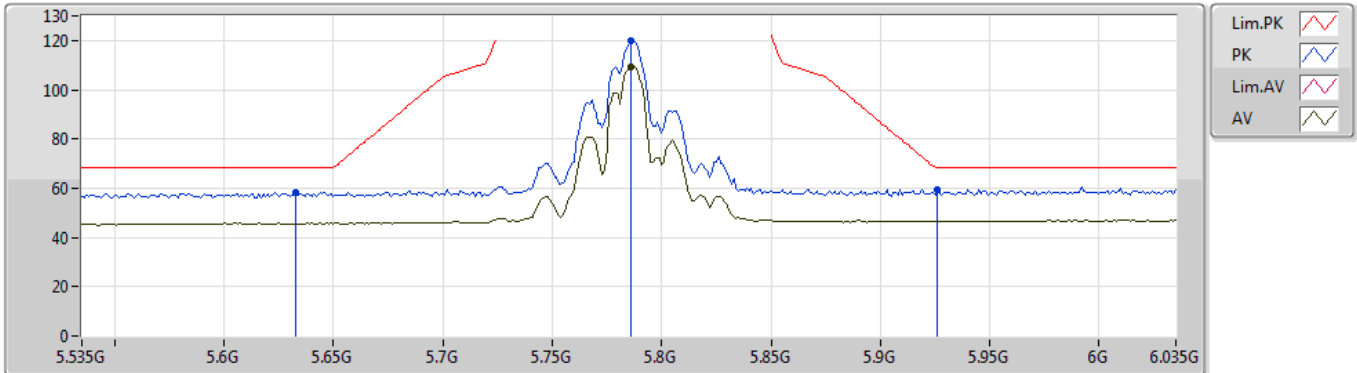

EUT Y_4TX
 Setting 22
 01-M-1-10
 Ant Dipole
 FSU(100015)

Type	Freq (Hz)	Level (dBuV/m)	Limit (dBuV/m)	Margin (dB)	Factor (dB)	Dist (m)	Condition	Azimuth (°)	Height (m)	Comment
PK	5.633G	58.35	68.20	-9.85	5.67	3	Horizontal	181	1.99	-
PK	5.786G	120.00	Inf	-Inf	5.92	3	Horizontal	181	1.99	-
AV	5.786G	109.49	Inf	-Inf	5.92	3	Horizontal	181	1.99	-
PK	5.926G	59.44	68.20	-8.76	6.81	3	Horizontal	181	1.99	-

802.11ac VHT20_Nss1,(MCS0)_4TX

11/04/2019

5785MHz_TX

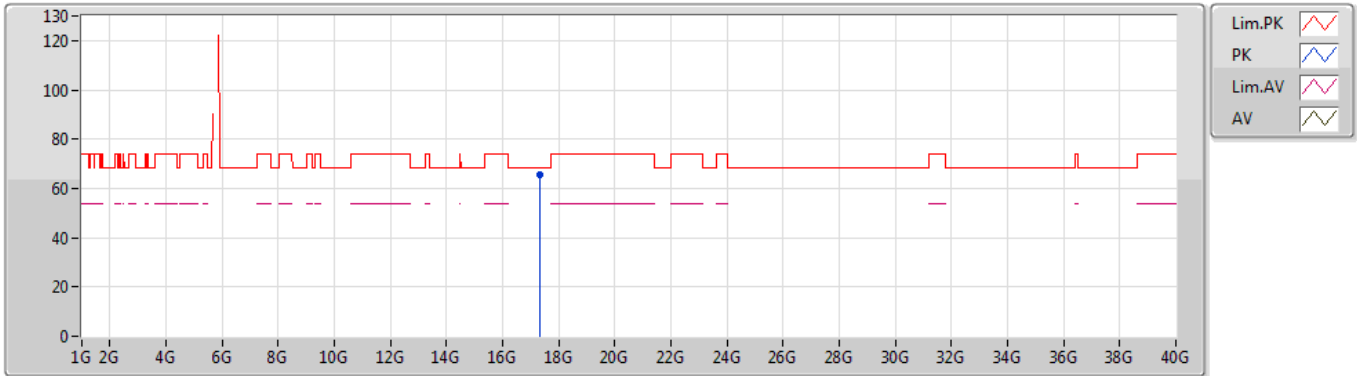

EUT Y_4TX
 Setting 22
 01-M-1
 Ant Dipole
 FSU(100015)

Type	Freq (Hz)	Level (dBuV/m)	Limit (dBuV/m)	Margin (dB)	Factor (dB)	Dist (m)	Condition	Azimuth (°)	Height (m)	Comment
PK	17.35104G	65.35	68.20	-2.85	18.26	3	Vertical	64	2.27	-

802.11ac VHT20_Nss1,(MCS0)_4TX

11/04/2019

5785MHz_TX

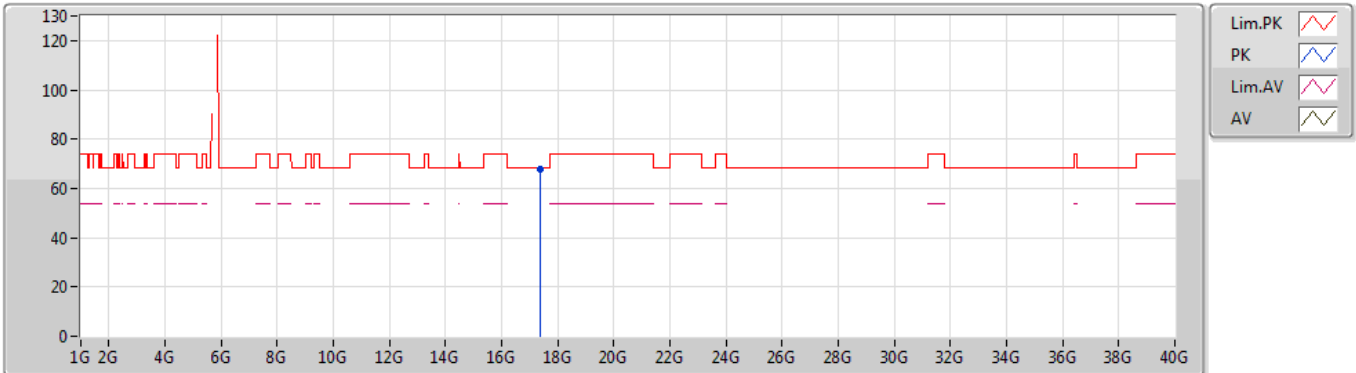

EUT Y_4TX
 Setting 22
 01-M-1
 Ant Dipole
 FSU(100015)

Type	Freq (Hz)	Level (dBuV/m)	Limit (dBuV/m)	Margin (dB)	Factor (dB)	Dist (m)	Condition	Azimuth (°)	Height (m)	Comment
PK	17.36148G	67.93	68.20	-0.27	18.27	3	Horizontal	311	2.45	-

802.11ac VHT20_Nss1,(MCS0)_4TX

11/04/2019

5825MHz_TX

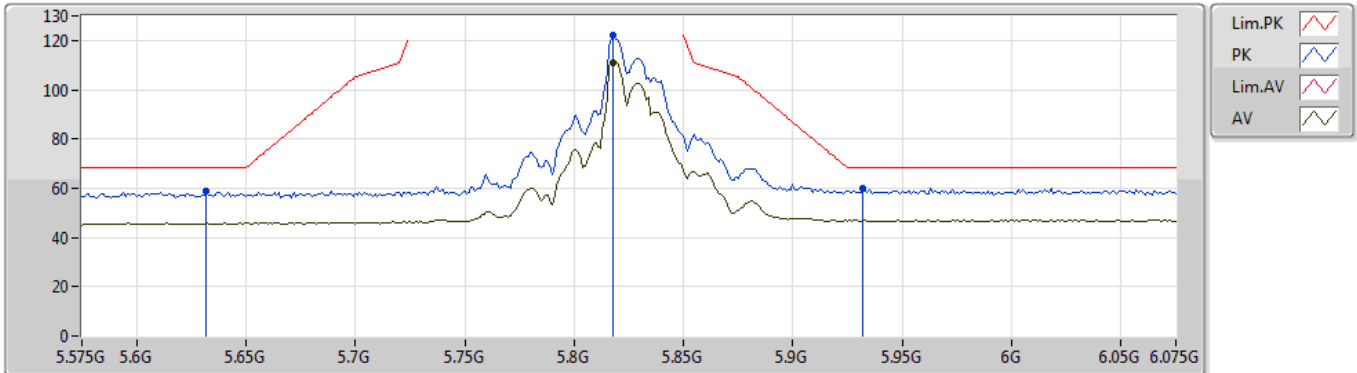

EUT Y_4TX
 Setting 22.5
 01-M-1-10
 Ant Dipole
 FSU(100015)

Type	Freq (Hz)	Level (dBuV/m)	Limit (dBuV/m)	Margin (dB)	Factor (dB)	Dist (m)	Condition	Azimuth (°)	Height (m)	Comment
PK	5.632G	58.60	68.20	-9.60	5.67	3	Vertical	68	1.46	-
PK	5.818G	122.05	Inf	-Inf	6.09	3	Vertical	68	1.46	-
AV	5.818G	111.21	Inf	-Inf	6.09	3	Vertical	68	1.46	-
PK	5.932G	59.75	68.20	-8.45	6.84	3	Vertical	68	1.46	-

802.11ac VHT20_Nss1,(MCS0)_4TX

11/04/2019

5825MHz_TX

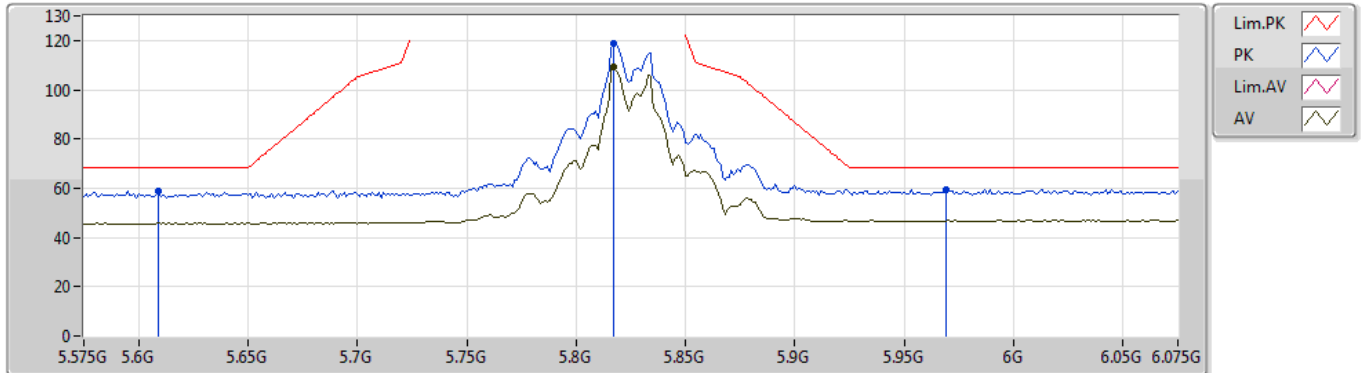

EUT Y_4TX
 Setting 22.5
 01-M-1-10
 Ant Dipole
 FSU(100015)

Type	Freq (Hz)	Level (dBuV/m)	Limit (dBuV/m)	Margin (dB)	Factor (dB)	Dist (m)	Condition	Azimuth (°)	Height (m)	Comment
PK	5.609G	58.66	68.20	-9.54	5.65	3	Horizontal	176	1.30	-
PK	5.817G	118.92	Inf	-Inf	6.08	3	Horizontal	176	1.30	-
AV	5.817G	109.33	Inf	-Inf	6.08	3	Horizontal	176	1.30	-
PK	5.969G	59.55	68.20	-8.65	7.02	3	Horizontal	176	1.30	-

802.11ac VHT20_Nss1,(MCS0)_4TX

11/04/2019

5825MHz_TX

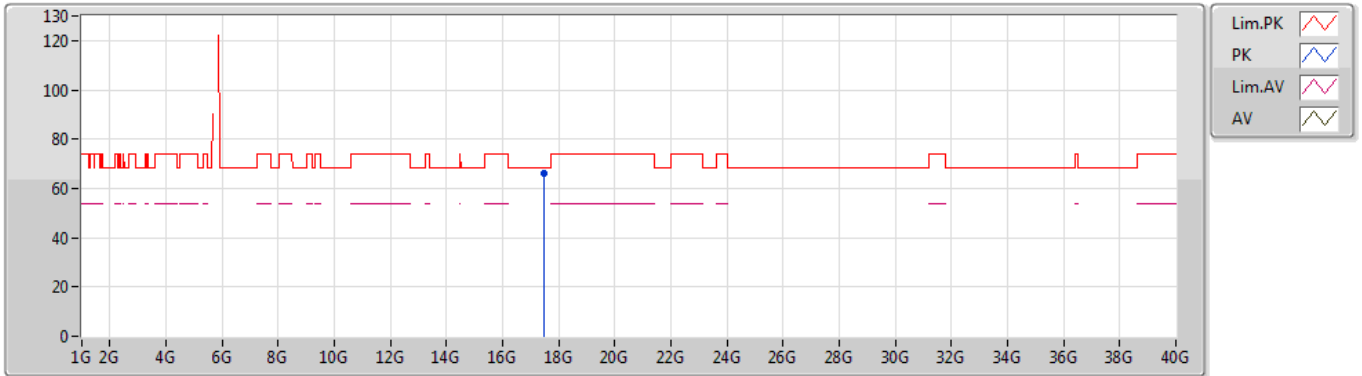

EUT Y_4TX
 Setting 22.5
 01-M-1
 Ant Dipole
 FSU(100015)

Type	Freq (Hz)	Level (dBuV/m)	Limit (dBuV/m)	Margin (dB)	Factor (dB)	Dist (m)	Condition	Azimuth (°)	Height (m)	Comment
PK	17.47824G	66.22	68.20	-1.98	18.48	3	Vertical	9	2.18	-

802.11ac VHT20_Nss1,(MCS0)_4TX

11/04/2019

5825MHz_TX

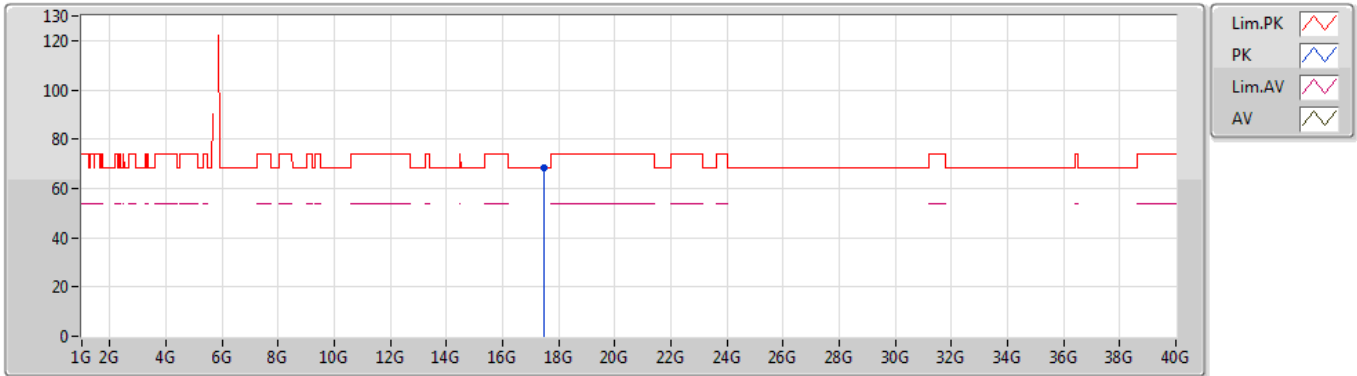

EUT Y_4TX
 Setting 22.5
 01-M-1
 Ant Dipole
 FSU(100015)

Type	Freq (Hz)	Level (dBuV/m)	Limit (dBuV/m)	Margin (dB)	Factor (dB)	Dist (m)	Condition	Azimuth (°)	Height (m)	Comment
PK	17.47332G	68.17	68.20	-0.03	18.47	3	Horizontal	307	1.84	-

802.11ac VHT40_Nss1,(MCS0)_4TX

11/04/2019

5190MHz_TX

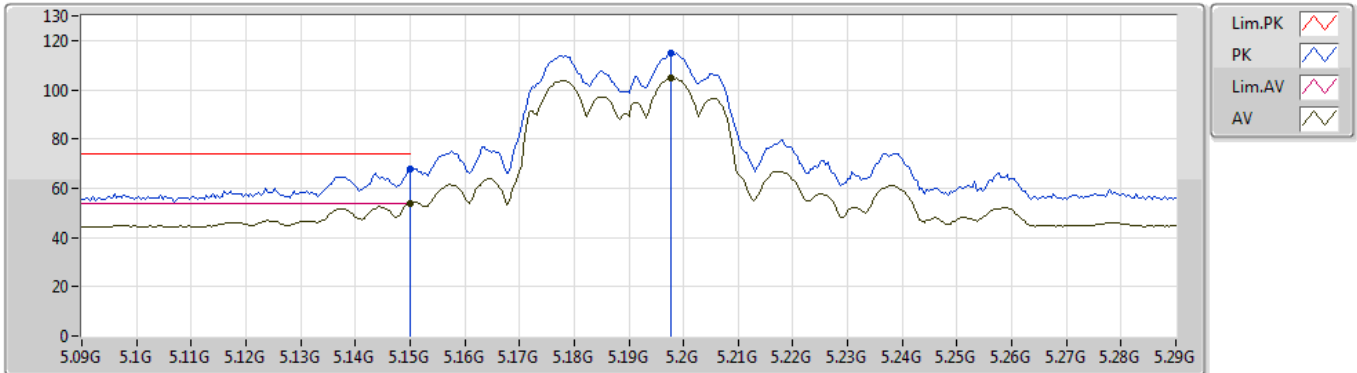

EUT Y_4TX
 Setting 19.5
 01-M-1-10
 Ant Dipole
 FSU(100015)

Type	Freq (Hz)	Level (dBuV/m)	Limit (dBuV/m)	Margin (dB)	Factor (dB)	Dist (m)	Condition	Azimuth (°)	Height (m)	Comment
PK	5.15G	67.71	74.00	-6.29	4.25	3	Vertical	63	2.30	-
AV	5.15G	53.97	54.00	-0.03	4.25	3	Vertical	63	2.30	-
PK	5.1976G	114.78	Inf	-Inf	4.27	3	Vertical	63	2.30	-
AV	5.1976G	104.61	Inf	-Inf	4.27	3	Vertical	63	2.30	-

802.11ac VHT40_Nss1,(MCS0)_4TX

11/04/2019

5190MHz_TX

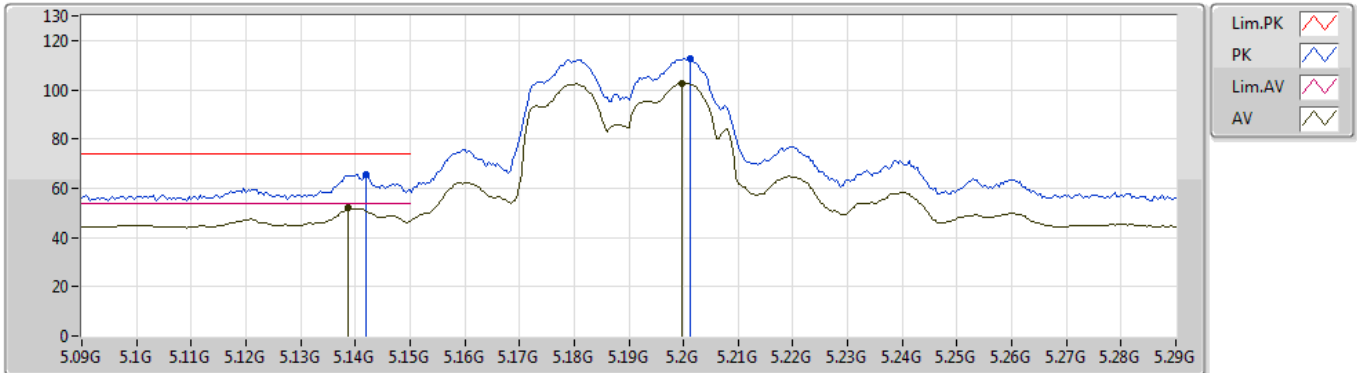

EUT Y_4TX
 Setting 19.5
 01-M-1-10
 Ant Dipole
 FSU(100015)

Type	Freq (Hz)	Level (dBuV/m)	Limit (dBuV/m)	Margin (dB)	Factor (dB)	Dist (m)	Condition	Azimuth (°)	Height (m)	Comment
PK	5.142G	65.65	74.00	-8.35	4.24	3	Horizontal	182	1.39	-
AV	5.1388G	51.94	54.00	-2.06	4.24	3	Horizontal	182	1.39	-
PK	5.2012G	112.62	Inf	-Inf	4.27	3	Horizontal	182	1.39	-
AV	5.1996G	102.65	Inf	-Inf	4.27	3	Horizontal	182	1.39	-

802.11ac VHT40_Nss1,(MCS0)_4TX

11/04/2019

5190MHz_TX

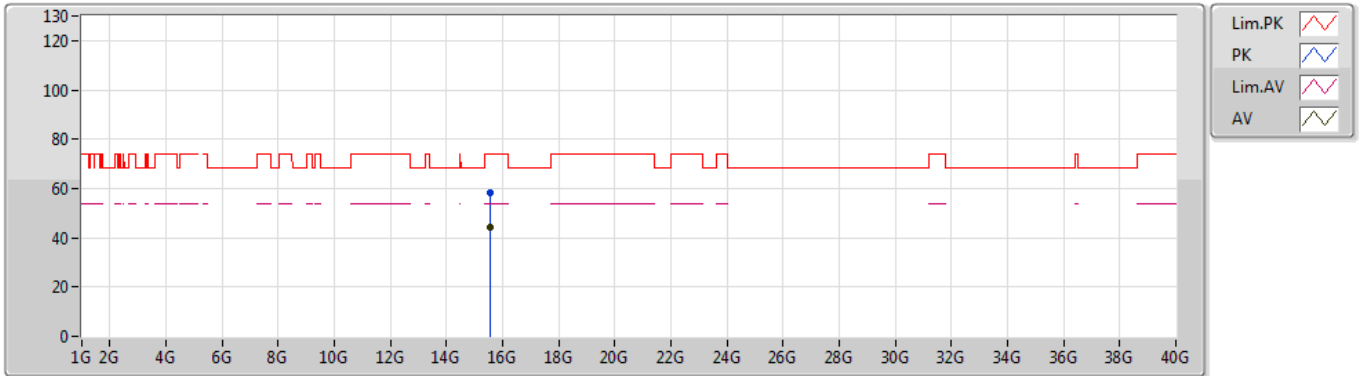

EUT Y_4TX
 Setting 19.5
 01-M-1
 Ant Dipole
 FSU(100015)

Type	Freq (Hz)	Level (dBuV/m)	Limit (dBuV/m)	Margin (dB)	Factor (dB)	Dist (m)	Condition	Azimuth (°)	Height (m)	Comment
PK	15.57152G	58.05	74.00	-15.95	14.42	3	Vertical	235	2.03	-
AV	15.56962G	44.25	54.00	-9.75	14.42	3	Vertical	235	2.03	-

802.11ac VHT40_Nss1,(MCS0)_4TX

11/04/2019

5190MHz_TX

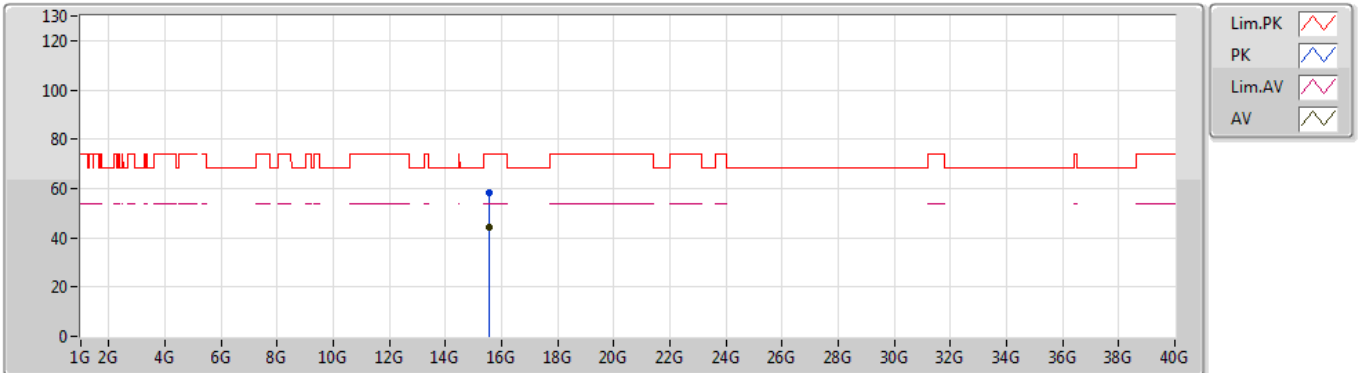

EUT Y_4TX
 Setting 19.5
 01-M-1
 Ant Dipole
 FSU(100015)

Type	Freq (Hz)	Level (dBuV/m)	Limit (dBuV/m)	Margin (dB)	Factor (dB)	Dist (m)	Condition	Azimuth (°)	Height (m)	Comment
PK	15.57174G	58.00	74.00	-16.00	14.42	3	Horizontal	346	1.96	-
AV	15.56859G	44.13	54.00	-9.87	14.42	3	Horizontal	346	1.96	-

802.11ac VHT40_Nss1,(MCS0)_4TX

11/04/2019

5230MHz_TX

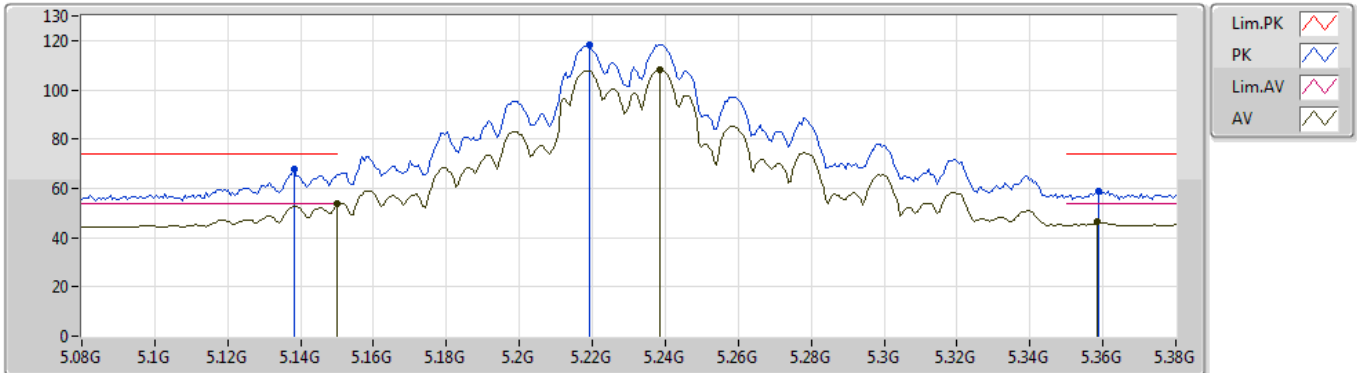

EUT_Y_4TX
Setting 23
01-M-1-10
Ant Dipole
FSU(100015)

Type	Freq (Hz)	Level (dBuV/m)	Limit (dBuV/m)	Margin (dB)	Factor (dB)	Dist (m)	Condition	Azimuth (°)	Height (m)	Comment
PK	5.1382G	67.75	74.00	-6.25	4.24	3	Vertical	62	2.33	-
AV	5.15G	53.90	54.00	-0.10	4.25	3	Vertical	62	2.33	-
PK	5.2192G	118.46	Inf	-Inf	4.34	3	Vertical	62	2.33	-
AV	5.2384G	108.25	Inf	-Inf	4.42	3	Vertical	62	2.33	-
PK	5.359G	59.05	74.00	-14.95	4.85	3	Vertical	62	2.33	-
AV	5.3584G	46.23	54.00	-7.77	4.85	3	Vertical	62	2.33	-

802.11ac VHT40_Nss1,(MCS0)_4TX

11/04/2019

5230MHz_TX

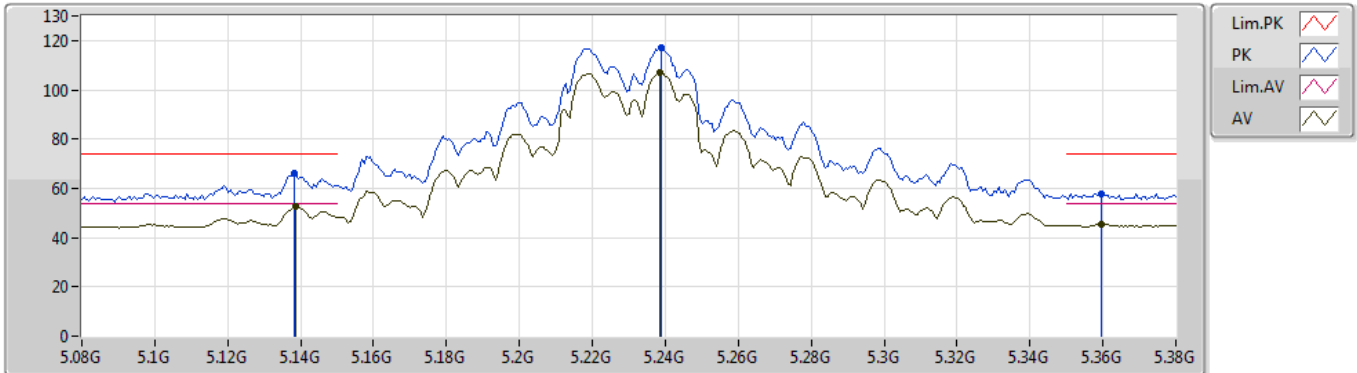

EUT_Y_4TX
Setting 23
01-M-1-10
Ant Dipole
FSU(100015)

Type	Freq (Hz)	Level (dBuV/m)	Limit (dBuV/m)	Margin (dB)	Factor (dB)	Dist (m)	Condition	Azimuth (°)	Height (m)	Comment
PK	5.1382G	66.32	74.00	-7.68	4.24	3	Horizontal	183	1.04	-
AV	5.1388G	52.54	54.00	-1.46	4.24	3	Horizontal	183	1.04	-
PK	5.239G	116.89	Inf	-Inf	4.42	3	Horizontal	183	1.04	-
AV	5.2384G	106.77	Inf	-Inf	4.42	3	Horizontal	183	1.04	-
PK	5.3596G	57.85	74.00	-16.15	4.85	3	Horizontal	183	1.04	-
AV	5.3596G	45.59	54.00	-8.41	4.85	3	Horizontal	183	1.04	-

802.11ac VHT40_Nss1,(MCS0)_4TX

11/04/2019

5230MHz_TX

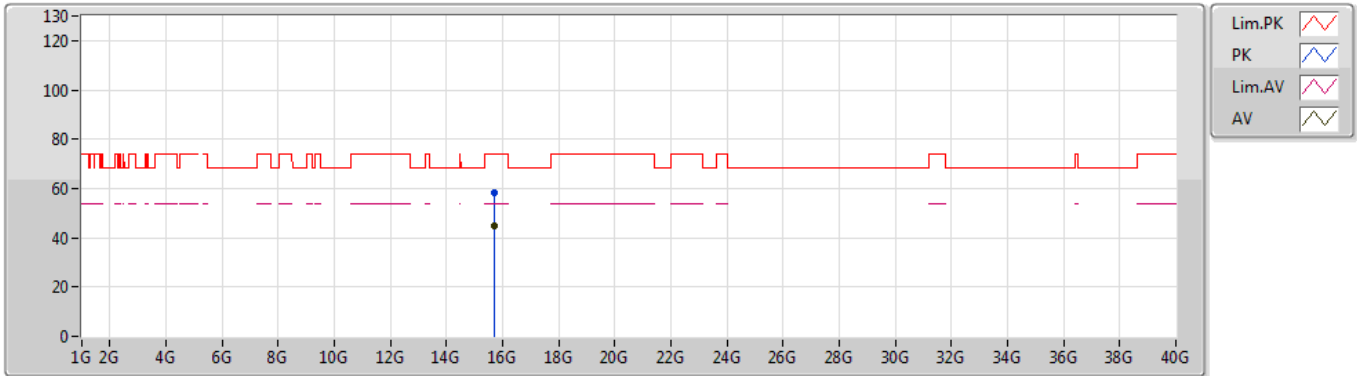

EUT Y_4TX
 Setting 23
 01-M-1
 Ant Dipole
 FSU(100015)

Type	Freq (Hz)	Level (dBuV/m)	Limit (dBuV/m)	Margin (dB)	Factor (dB)	Dist (m)	Condition	Azimuth (°)	Height (m)	Comment
PK	15.68914G	58.49	74.00	-15.51	14.28	3	Vertical	134	2.15	-
AV	15.68775G	44.68	54.00	-9.32	14.28	3	Vertical	134	2.15	-

802.11ac VHT40_Nss1,(MCS0)_4TX

11/04/2019

5230MHz_TX

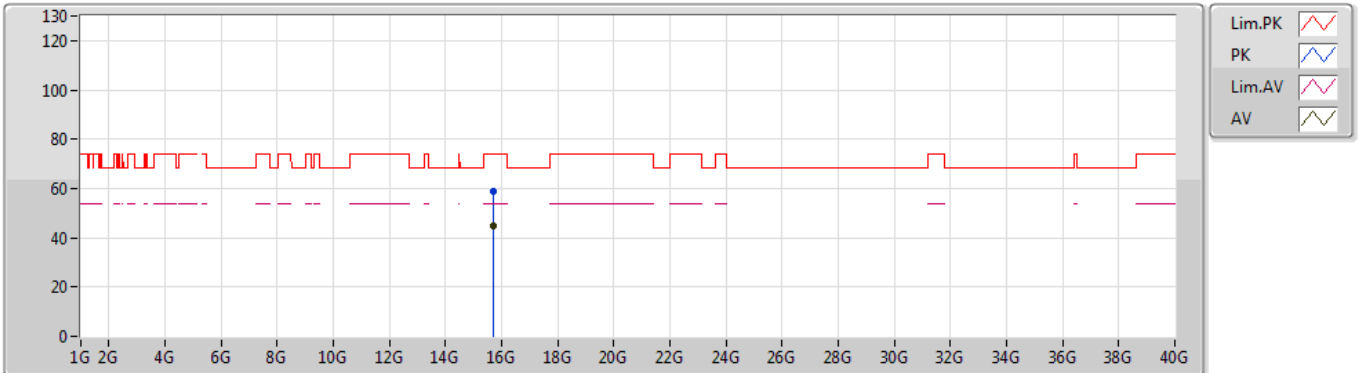

EUT Y_4TX
 Setting 23
 01-M-1
 Ant Dipole
 FSU(100015)

Type	Freq (Hz)	Level (dBuV/m)	Limit (dBuV/m)	Margin (dB)	Factor (dB)	Dist (m)	Condition	Azimuth (°)	Height (m)	Comment
PK	15.69042G	58.69	74.00	-15.31	14.28	3	Horizontal	357	1.33	-
AV	15.6922G	44.86	54.00	-9.14	14.27	3	Horizontal	357	1.33	-

802.11ac VHT40_Nss1,(MCS0)_4TX

11/04/2019

5755MHz_TX

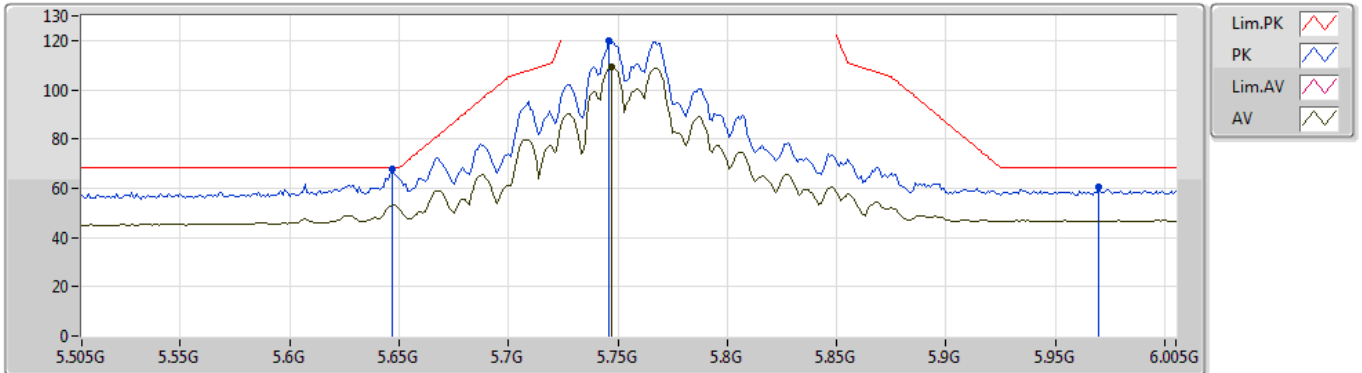

EUT Y_4TX
 Setting 23
 01-M-1-10
 Ant Dipole
 FSU(100015)

Type	Freq (Hz)	Level (dBuV/m)	Limit (dBuV/m)	Margin (dB)	Factor (dB)	Dist (m)	Condition	Azimuth (°)	Height (m)	Comment
PK	5.647G	67.60	68.20	-0.60	5.69	3	Vertical	72	1.48	-
PK	5.746G	119.64	Inf	-Inf	5.84	3	Vertical	72	1.48	-
AV	5.747G	109.24	Inf	-Inf	5.84	3	Vertical	72	1.48	-
PK	5.97G	60.59	68.20	-7.61	7.02	3	Vertical	72	1.48	-

802.11ac VHT40_Nss1,(MCS0)_4TX

11/04/2019

5755MHz_TX

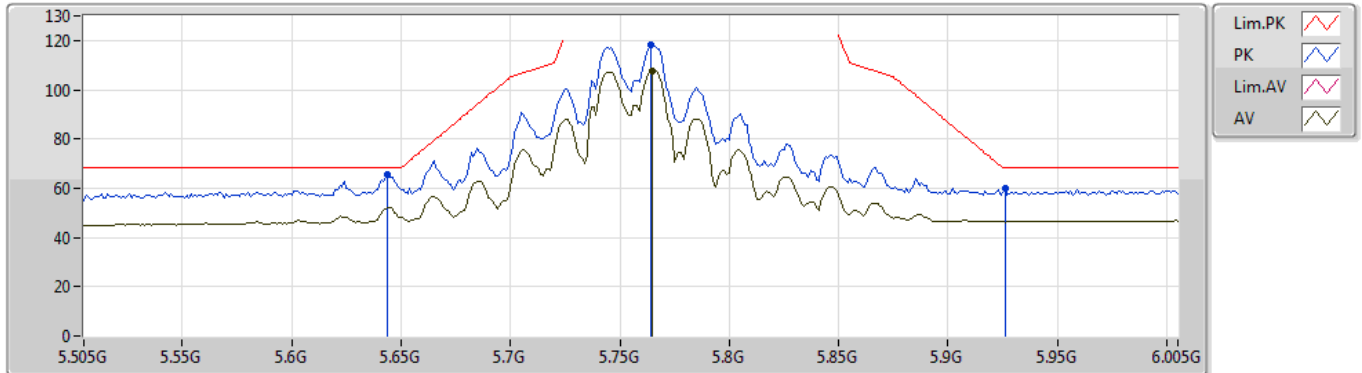

EUT Y_4TX
 Setting 23
 01-M-1-10
 Ant Dipole
 FSU(100015)

Type	Freq (Hz)	Level (dBuV/m)	Limit (dBuV/m)	Margin (dB)	Factor (dB)	Dist (m)	Condition	Azimuth (°)	Height (m)	Comment
PK	5.644G	65.62	68.20	-2.58	5.68	3	Horizontal	176	1.32	-
PK	5.764G	118.12	Inf	-Inf	5.89	3	Horizontal	176	1.32	-
AV	5.765G	107.78	Inf	-Inf	5.89	3	Horizontal	176	1.32	-
PK	5.926G	59.70	68.20	-8.50	6.81	3	Horizontal	176	1.32	-

802.11ac VHT40_Nss1,(MCS0)_4TX

11/04/2019

5755MHz_TX

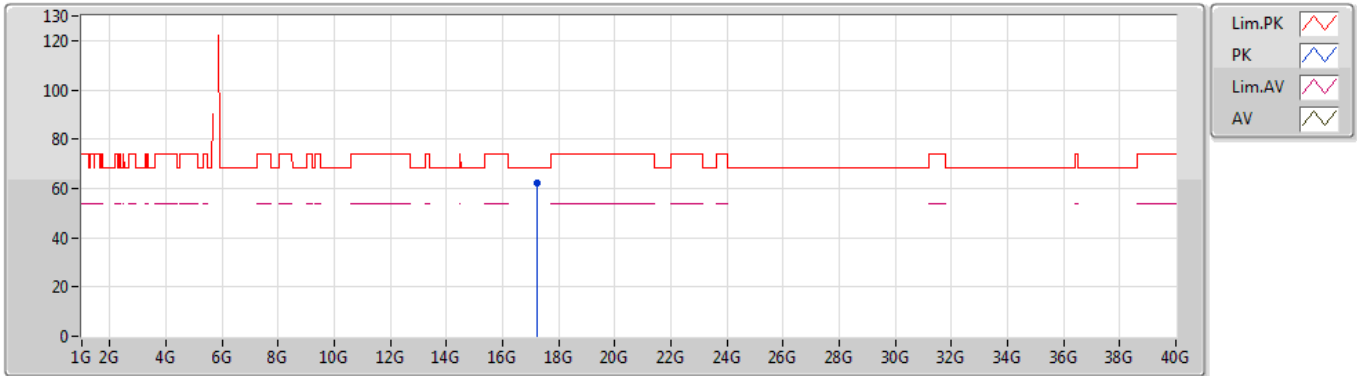

EUT Y_4TX
 Setting 23
 01-M-1
 Ant Dipole
 FSU(100015)

Type	Freq (Hz)	Level (dBuV/m)	Limit (dBuV/m)	Margin (dB)	Factor (dB)	Dist (m)	Condition	Azimuth (°)	Height (m)	Comment
PK	17.25044G	62.20	68.20	-6.00	18.08	3	Vertical	304	1.50	-

802.11ac VHT40_Nss1,(MCS0)_4TX

11/04/2019

5755MHz_TX

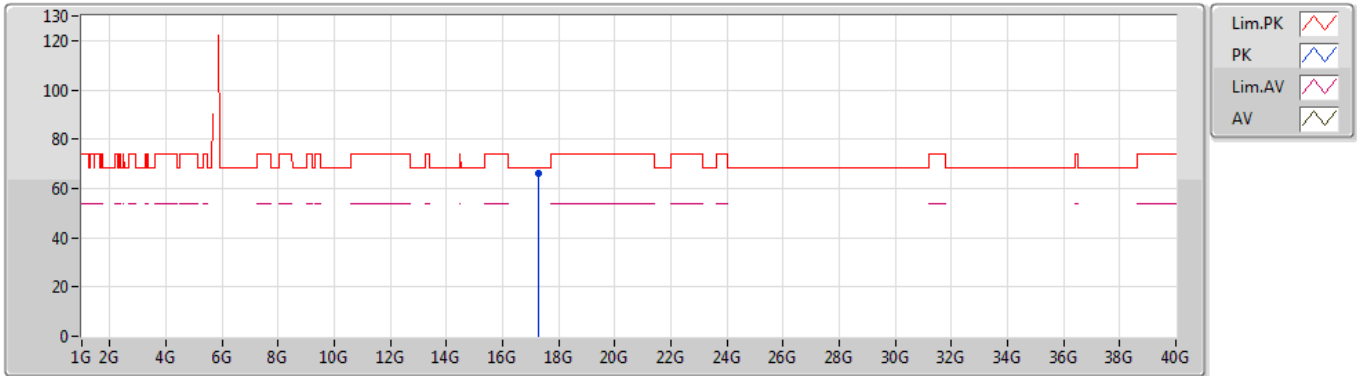

EUT Y_4TX
 Setting 23
 01-M-1
 Ant Dipole
 FSU(100015)

Type	Freq (Hz)	Level (dBuV/m)	Limit (dBuV/m)	Margin (dB)	Factor (dB)	Dist (m)	Condition	Azimuth (°)	Height (m)	Comment
PK	17.25492G	66.39	68.20	-1.81	18.08	3	Horizontal	308	1.53	-

802.11ac VHT40_Nss1,(MCS0)_4TX

11/04/2019

5795MHz_TX

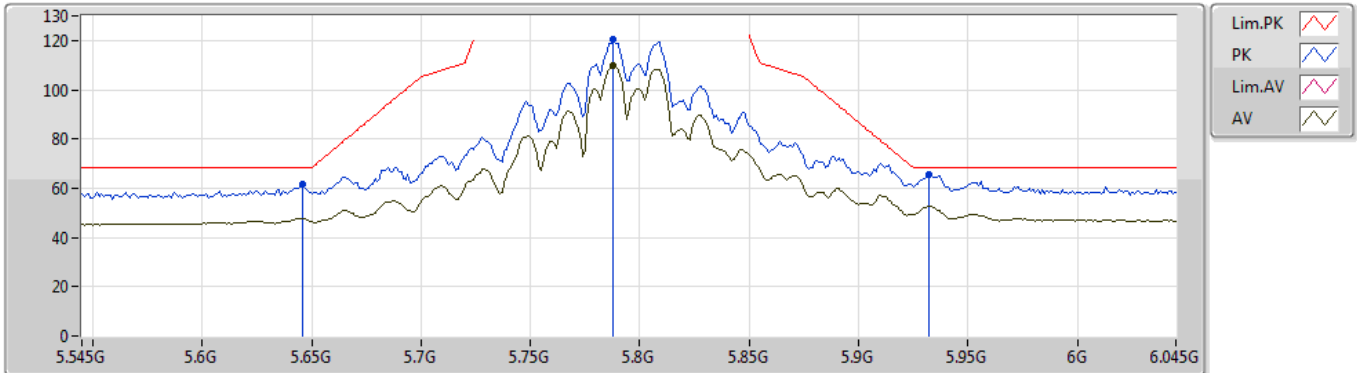

EUT Y_4TX
 Setting 23
 01-M-1-10
 Ant Dipole
 FSU(100015)

Type	Freq (Hz)	Level (dBuV/m)	Limit (dBuV/m)	Margin (dB)	Factor (dB)	Dist (m)	Condition	Azimuth (°)	Height (m)	Comment
PK	5.646G	61.47	68.20	-6.73	5.69	3	Vertical	69	1.49	-
PK	5.788G	120.39	Inf	-Inf	5.94	3	Vertical	69	1.49	-
AV	5.788G	109.62	Inf	-Inf	5.94	3	Vertical	69	1.49	-
PK	5.932G	65.79	68.20	-2.41	6.84	3	Vertical	69	1.49	-

802.11ac VHT40_Nss1,(MCS0)_4TX

11/04/2019

5795MHz_TX

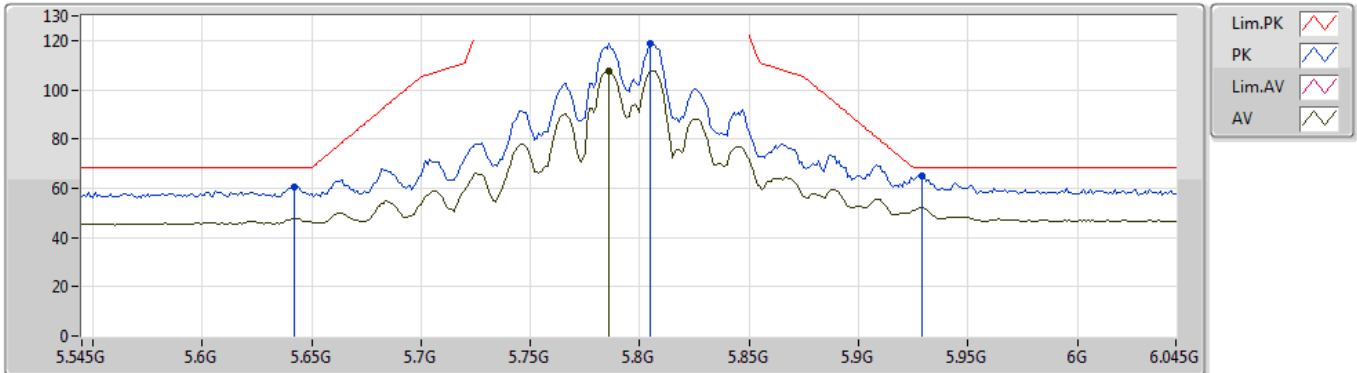

EUT Y_4TX
Setting 23
01-M-1-10
Ant Dipole
FSU(100015)

Type	Freq (Hz)	Level (dBuV/m)	Limit (dBuV/m)	Margin (dB)	Factor (dB)	Dist (m)	Condition	Azimuth (°)	Height (m)	Comment
PK	5.642G	60.56	68.20	-7.64	5.68	3	Horizontal	176	1.30	-
PK	5.805G	118.89	Inf	-Inf	6.00	3	Horizontal	176	1.30	-
AV	5.786G	107.64	Inf	-Inf	5.92	3	Horizontal	176	1.30	-
PK	5.929G	65.09	68.20	-3.11	6.83	3	Horizontal	176	1.30	-

802.11ac VHT40_Nss1,(MCS0)_4TX

11/04/2019

5795MHz_TX

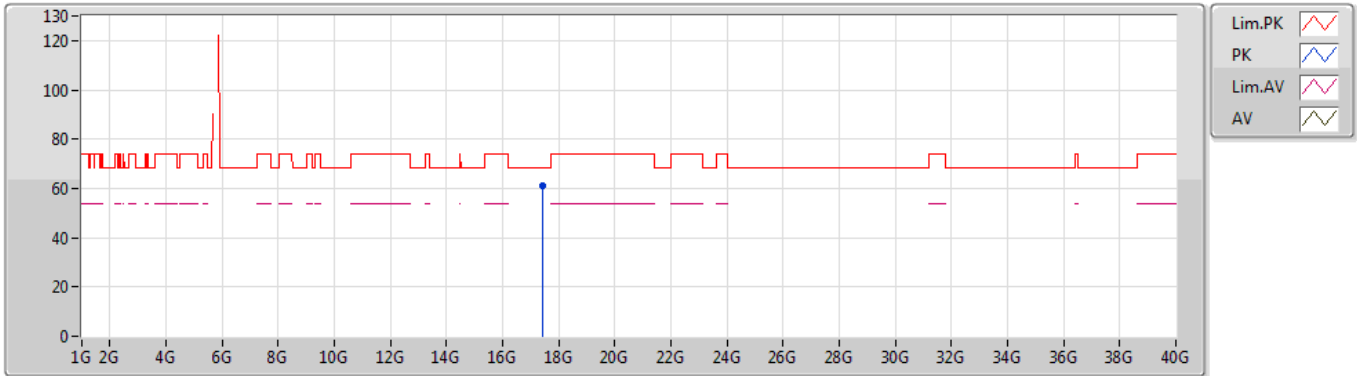

EUT Y_4TX
 Setting 23
 01-M-1
 Ant Dipole
 FSU(100015)

Type	Freq (Hz)	Level (dBuV/m)	Limit (dBuV/m)	Margin (dB)	Factor (dB)	Dist (m)	Condition	Azimuth (°)	Height (m)	Comment
PK	17.423G	61.07	68.20	-7.13	18.38	3	Vertical	50	2.02	-

802.11ac VHT40_Nss1,(MCS0)_4TX

11/04/2019

5795MHz_TX

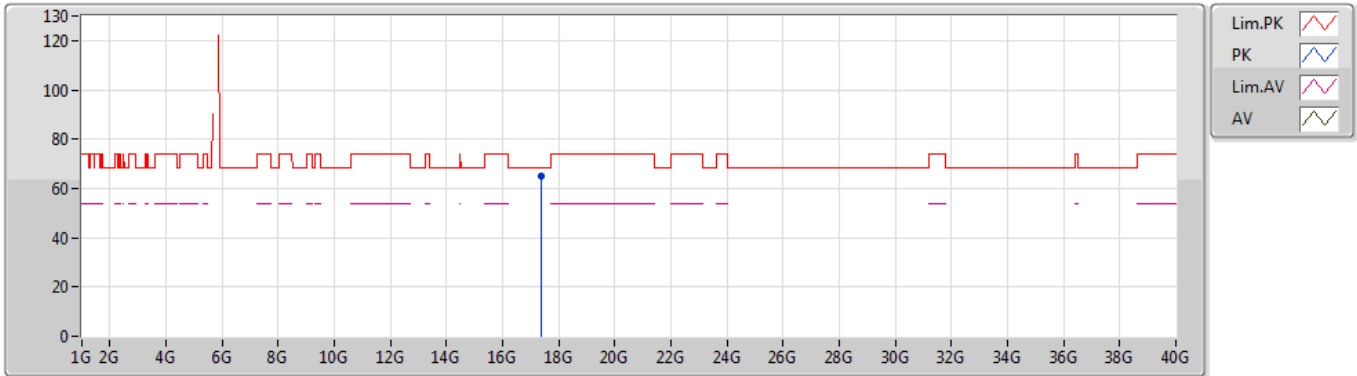

EUT Y_4TX
 Setting 23
 01-M-1
 Ant Dipole
 FSU(100015)

Type	Freq (Hz)	Level (dBuV/m)	Limit (dBuV/m)	Margin (dB)	Factor (dB)	Dist (m)	Condition	Azimuth (°)	Height (m)	Comment
PK	17.353G	64.98	68.20	-3.22	18.26	3	Horizontal	311	2.45	-

802.11ac VHT80_Nss1,(MCS0)_4TX

11/04/2019

5210MHz_TX

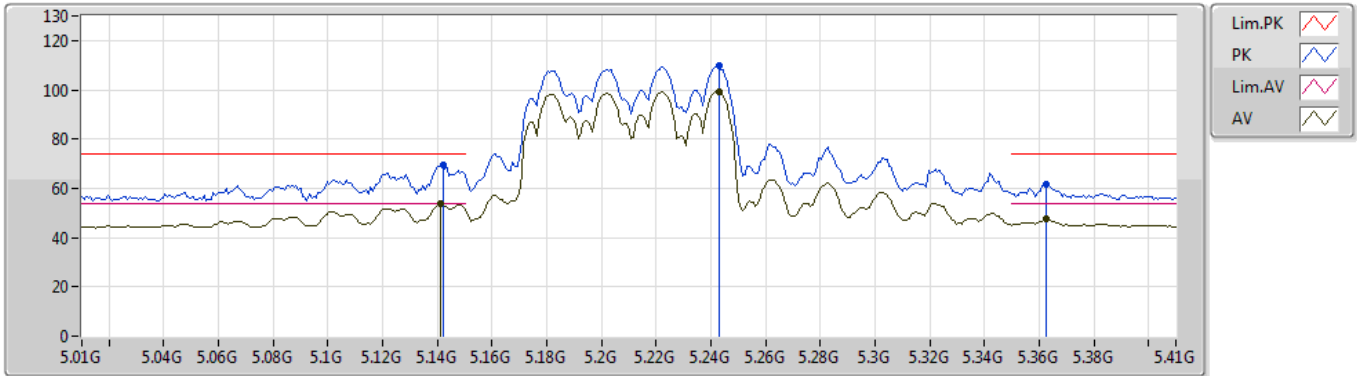

EUT_Y_4TX
 Setting 17.5
 01-M-1-10
 Ant Dipole
 FSU(100015)

Type	Freq (Hz)	Level (dBuV/m)	Limit (dBuV/m)	Margin (dB)	Factor (dB)	Dist (m)	Condition	Azimuth (°)	Height (m)	Comment
PK	5.142G	69.66	74.00	-4.34	4.24	3	Vertical	62	1.58	-
AV	5.1412G	53.82	54.00	-0.18	4.24	3	Vertical	62	1.58	-
PK	5.2428G	109.78	Inf	-Inf	4.43	3	Vertical	62	1.58	-
AV	5.2428G	99.36	Inf	-Inf	4.43	3	Vertical	62	1.58	-
PK	5.3628G	61.67	74.00	-12.33	4.86	3	Vertical	62	1.58	-
AV	5.3628G	47.48	54.00	-6.52	4.86	3	Vertical	62	1.58	-

802.11ac VHT80_Nss1,(MCS0)_4TX

11/04/2019

5210MHz_TX

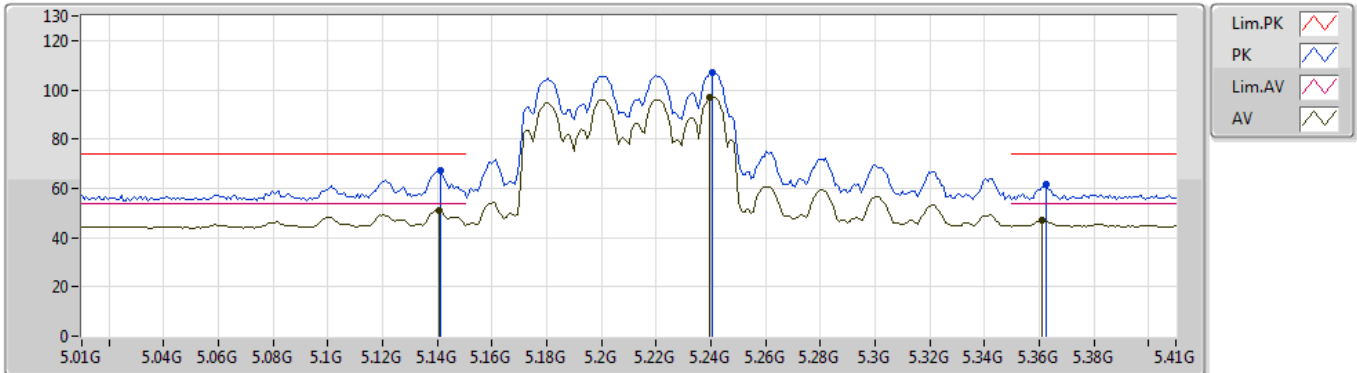

EUT Y_4TX
 Setting 17.5
 01-M-1-10
 Ant Dipole
 FSU(100015)

Type	Freq (Hz)	Level (dBuV/m)	Limit (dBuV/m)	Margin (dB)	Factor (dB)	Dist (m)	Condition	Azimuth (°)	Height (m)	Comment
PK	5.1412G	67.28	74.00	-6.72	4.24	3	Horizontal	172	2.70	-
AV	5.1404G	51.17	54.00	-2.83	4.24	3	Horizontal	172	2.70	-
PK	5.2404G	107.12	Inf	-Inf	4.42	3	Horizontal	172	2.70	-
AV	5.2396G	97.12	Inf	-Inf	4.42	3	Horizontal	172	2.70	-
PK	5.3628G	61.39	74.00	-12.61	4.86	3	Horizontal	172	2.70	-
AV	5.3612G	47.20	54.00	-6.80	4.85	3	Horizontal	172	2.70	-

802.11ac VHT80_Nss1,(MCS0)_4TX

11/04/2019

5210MHz_TX

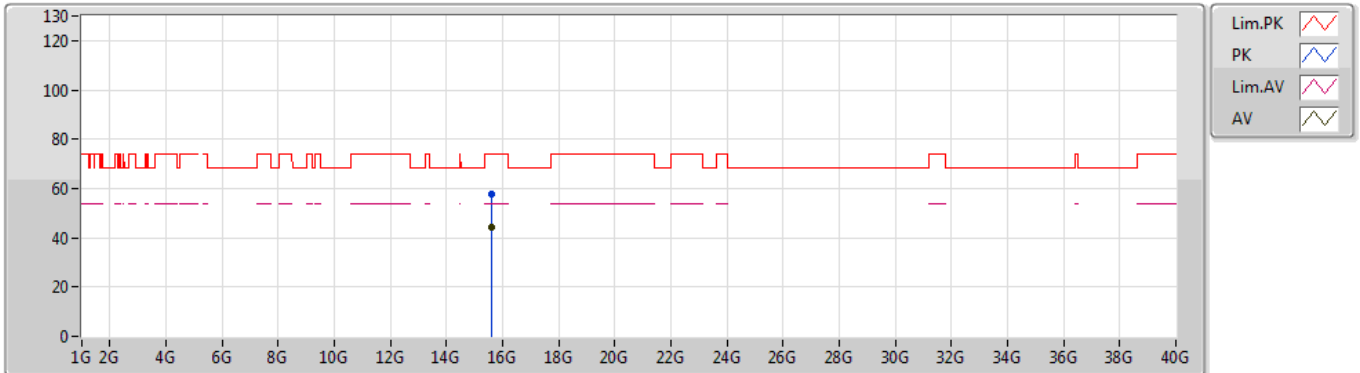

EUT Y_4TX
 Setting 17.5
 01-M-1
 Ant Dipole
 FSU(100015)

Type	Freq (Hz)	Level (dBuV/m)	Limit (dBuV/m)	Margin (dB)	Factor (dB)	Dist (m)	Condition	Azimuth (°)	Height (m)	Comment
PK	15.63007G	57.71	74.00	-16.29	14.34	3	Vertical	255	1.99	-
AV	15.63112G	44.27	54.00	-9.73	14.34	3	Vertical	255	1.99	-

802.11ac VHT80_Nss1,(MCS0)_4TX

11/04/2019

5210MHz_TX

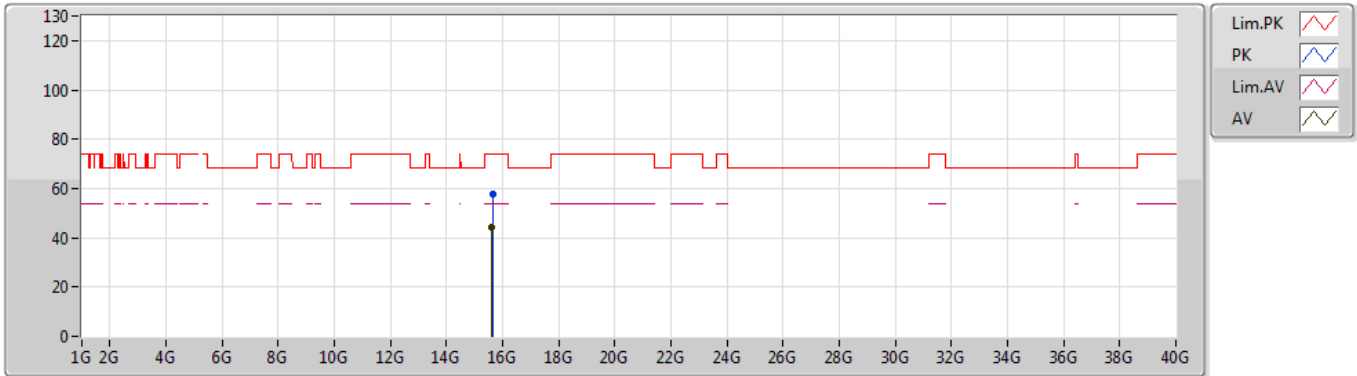

EUT Y_4TX
 Setting 17.5
 01-M-1
 Ant Dipole
 FSU(100015)

Type	Freq (Hz)	Level (dBuV/m)	Limit (dBuV/m)	Margin (dB)	Factor (dB)	Dist (m)	Condition	Azimuth (°)	Height (m)	Comment
PK	15.63125G	57.70	74.00	-16.30	14.34	3	Horizontal	47	2.40	-
AV	15.62785G	44.37	54.00	-9.63	14.34	3	Horizontal	47	2.40	-

802.11ac VHT80_Nss1,(MCS0)_4TX

11/04/2019

5775MHz_TX

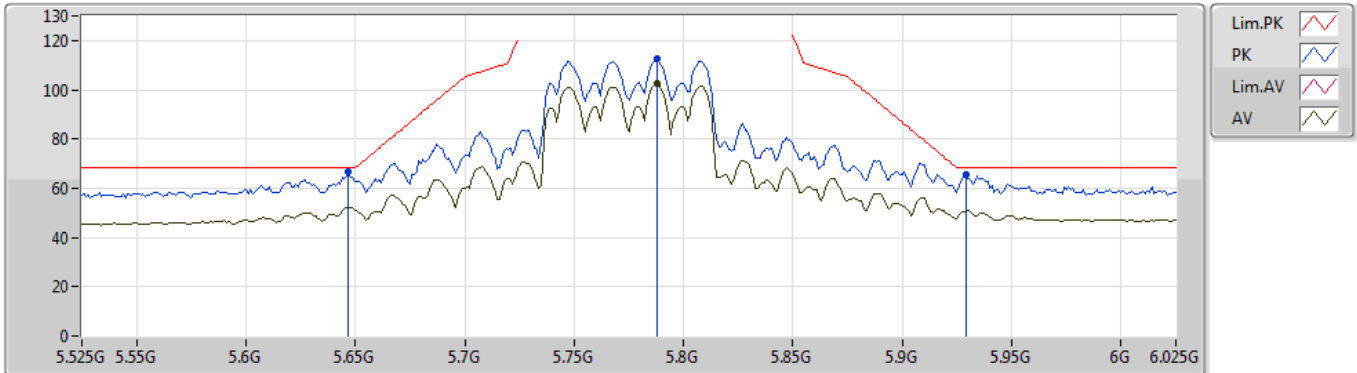

EUT Y_4TX
 Setting 19.5
 01-M-1-10
 Ant Dipole
 FSU(100015)

Type	Freq (Hz)	Level (dBuV/m)	Limit (dBuV/m)	Margin (dB)	Factor (dB)	Dist (m)	Condition	Azimuth (°)	Height (m)	Comment
PK	5.647G	66.77	68.20	-1.43	5.69	3	Vertical	68	1.49	-
PK	5.788G	112.61	Inf	-Inf	5.94	3	Vertical	68	1.49	-
AV	5.788G	102.43	Inf	-Inf	5.94	3	Vertical	68	1.49	-
PK	5.929G	65.50	68.20	-2.70	6.83	3	Vertical	68	1.49	-

802.11ac VHT80_Nss1,(MCS0)_4TX

11/04/2019

5775MHz_TX

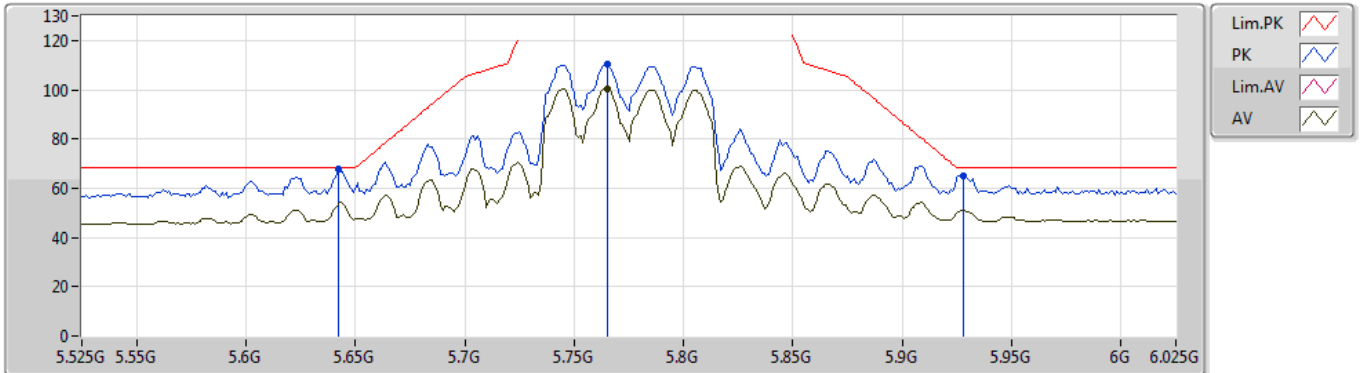

EUT Y_4TX
 Setting 19.5
 01-M-1-10
 Ant Dipole
 FSU(100015)

Type	Freq (Hz)	Level (dBuV/m)	Limit (dBuV/m)	Margin (dB)	Factor (dB)	Dist (m)	Condition	Azimuth (°)	Height (m)	Comment
PK	5.642G	68.03	68.20	-0.17	5.68	3	Horizontal	175	1.24	-
PK	5.765G	110.58	Inf	-Inf	5.89	3	Horizontal	175	1.24	-
AV	5.765G	100.48	Inf	-Inf	5.89	3	Horizontal	175	1.24	-
PK	5.928G	65.20	68.20	-3.00	6.82	3	Horizontal	175	1.24	-

802.11ac VHT80_Nss1,(MCS0)_4TX

11/04/2019

5775MHz_TX

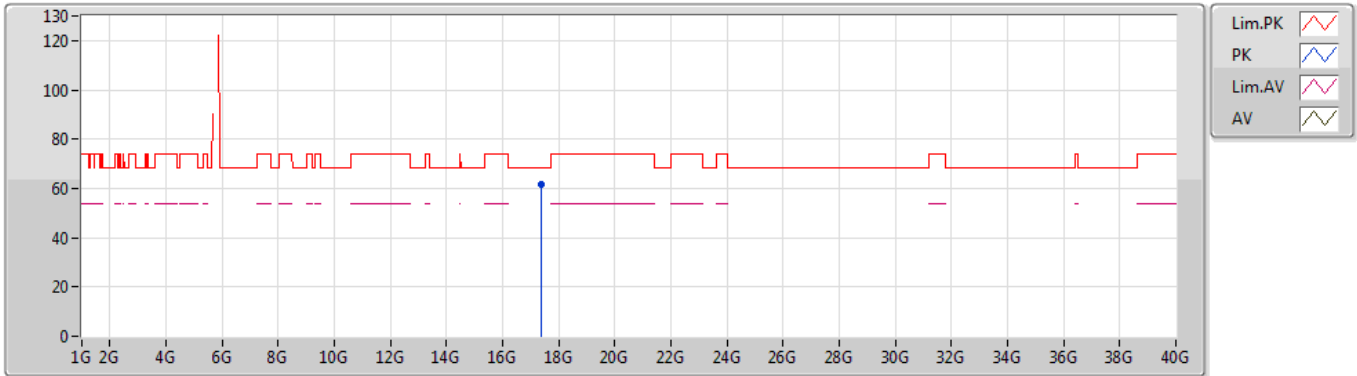

EUT Y_4TX
 Setting 19.5
 01-M-1
 Ant Dipole
 FSU(100015)

Type	Freq (Hz)	Level (dBuV/m)	Limit (dBuV/m)	Margin (dB)	Factor (dB)	Dist (m)	Condition	Azimuth (°)	Height (m)	Comment
PK	17.35756G	61.68	68.20	-6.52	18.14	3	Vertical	304	2.29	-

802.11ac VHT80_Nss1,(MCS0)_4TX

11/04/2019

5775MHz_TX

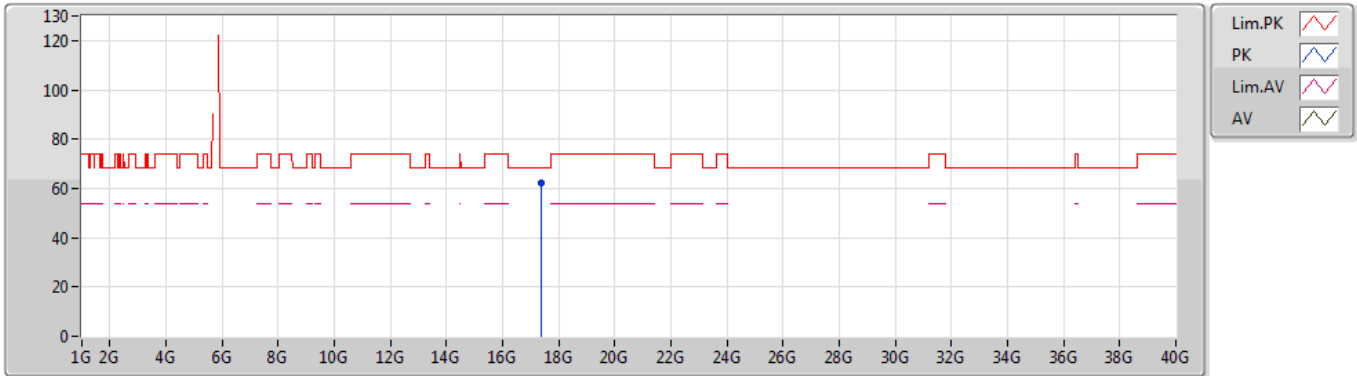

EUT_Y_4TX
 Setting 19.5
 01-M-1
 Ant Dipole
 FSU(100015)

Type	Freq (Hz)	Level (dBuV/m)	Limit (dBuV/m)	Margin (dB)	Factor (dB)	Dist (m)	Condition	Azimuth (°)	Height (m)	Comment
PK	17.35732G	62.20	68.20	-6.00	18.27	3	Horizontal	308	1.61	-



RSE TX above 1GHz Result

Appendix E.2.2

For Radio 3 Summary

Mode	Result	Type	Freq (Hz)	Level (dBuV/m)	Limit (dBuV/m)	Margin (dB)	Factor (dB)	Dist (m)	Condition	Azimuth (°)	Height (m)	Comments
5.15-5.25GHz	-	-	-	-	-	-	-	-	-	-	-	-
802.11ac VHT40_Nss1,(MCS0)_2TX	Pass	AV	5.1424G	53.97	54.00	-0.03	4.24	3	Vertical	294	1.01	-



802.11a_Nss1,(6Mbps)_2TX

08/04/2019

5180MHz_TX

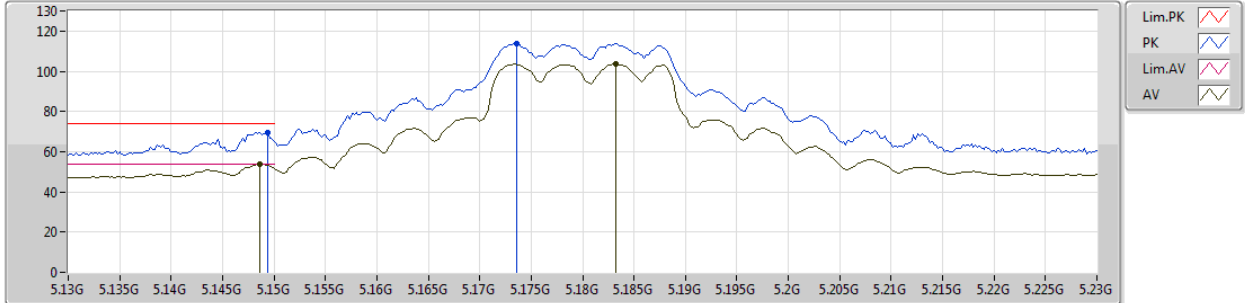

EUT_Z_2TX
 Setting 16.5
 01-D-1-10
 Ant Dipole
 FSU(100015)

Type	Freq (Hz)	Level (dBuV/m)	Limit (dBuV/m)	Margin (dB)	Factor (dB)	Dist (m)	Condition	Azimuth (°)	Height (m)	Comments
PK	5.1494G	69.48	74.00	-4.52	4.25	3	Vertical	297	1.01	-
AV	5.1486G	53.80	54.00	-0.20	4.25	3	Vertical	297	1.01	-
PK	5.1736G	114.02	Inf	-Inf	4.25	3	Vertical	297	1.01	-
AV	5.1832G	103.60	Inf	-Inf	4.26	3	Vertical	297	1.01	-



802.11a_Nss1,(6Mbps)_2TX

08/04/2019

5180MHz_TX

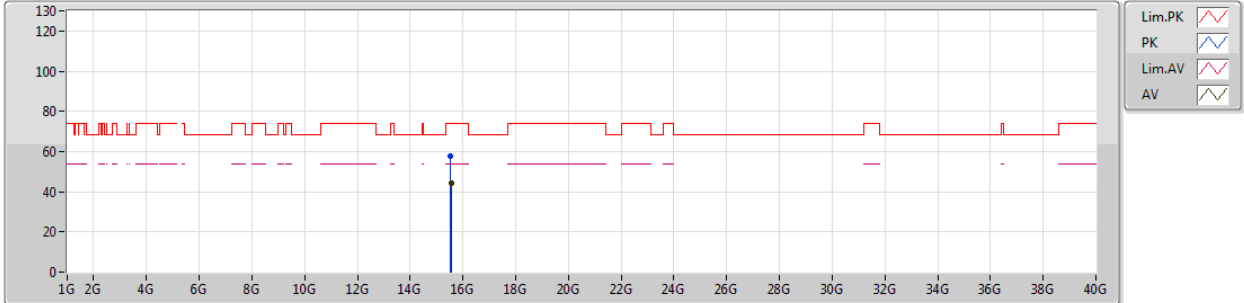

EUT_Z_2TX
 Setting 16.5
 01-E-2
 Ant Dipole
 FSU(100015)

Type	Freq (Hz)	Level (dBuV/m)	Limit (dBuV/m)	Margin (dB)	Factor (dB)	Dist (m)	Condition	Azimuth (°)	Height (m)	Comments
PK	15.53982G	57.61	74.00	-16.39	14.46	3	Vertical	341	1.50	-
AV	15.55392G	44.06	54.00	-9.94	14.44	3	Vertical	341	1.50	-



802.11a_Nss1,(6Mbps)_2TX

08/04/2019

5180MHz_TX

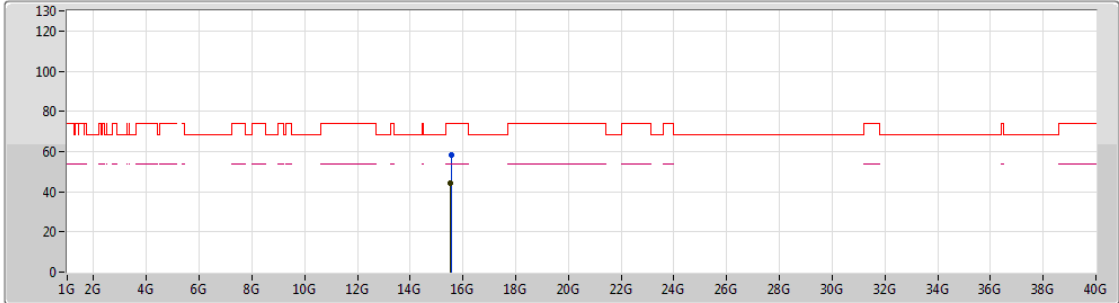

Lim.PK
 PK
 Lim.AV
 AV

EUT_Z_2TX
 Setting 16.5
 01-E-2
 Ant Dipole
 FSU(100015)

Type	Freq (Hz)	Level (dBuV/m)	Limit (dBuV/m)	Margin (dB)	Factor (dB)	Dist (m)	Condition	Azimuth (°)	Height (m)	Comments
PK	15.55482G	58.04	74.00	-15.96	14.44	3	Horizontal	1	1.50	-
AV	15.5445G	44.01	54.00	-9.99	14.45	3	Horizontal	1	1.50	-



802.11a_Nss1,(6Mbps)_2TX

08/04/2019

5200MHz_TX

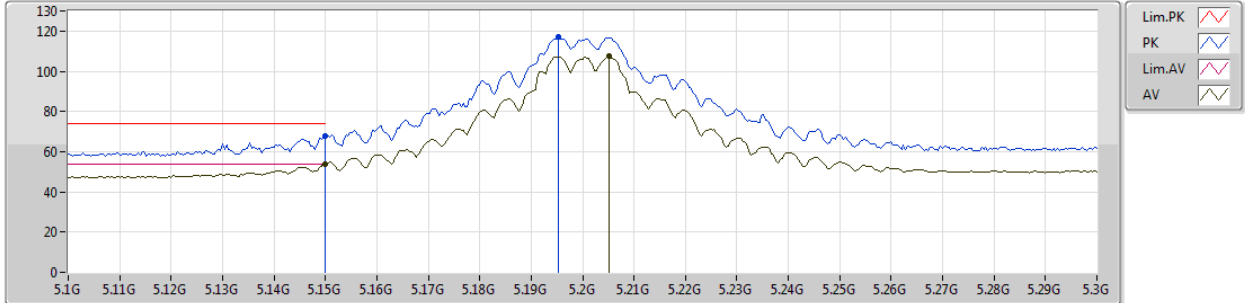

EUT_Z_2TX
Setting 22
01-D-1-10
Ant Dipole
FSU(100015)

Type	Freq (Hz)	Level (dBuV/m)	Limit (dBuV/m)	Margin (dB)	Factor (dB)	Dist (m)	Condition	Azimuth (°)	Height (m)	Comments
PK	5.15G	67.62	74.00	-6.38	4.25	3	Vertical	293	1.01	-
AV	5.15G	53.83	54.00	-0.17	4.25	3	Vertical	293	1.01	-
PK	5.1952G	116.92	Inf	-Inf	4.27	3	Vertical	293	1.01	-
AV	5.2052G	107.51	Inf	-Inf	4.29	3	Vertical	293	1.01	-



802.11a_Nss1,(6Mbps)_2TX

08/04/2019

5200MHz_TX

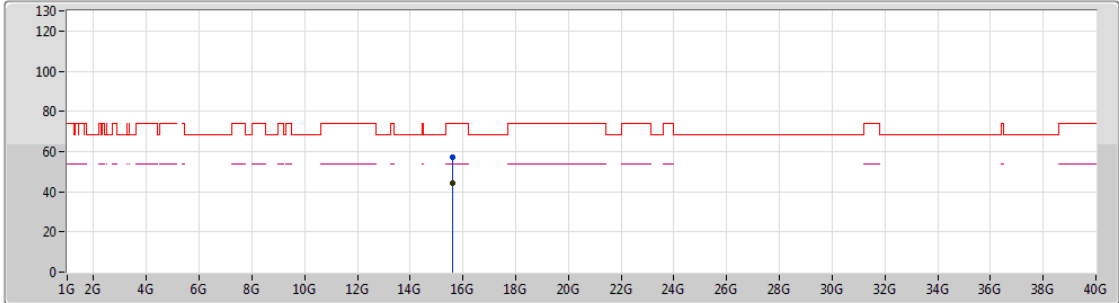

Lim.PK
 PK
 Lim.AV
 AV

EUT_Z_2TX
 Setting 22
 01-E-2
 Ant Dipole
 FSU(100015)

Type	Freq (Hz)	Level (dBuV/m)	Limit (dBuV/m)	Margin (dB)	Factor (dB)	Dist (m)	Condition	Azimuth (°)	Height (m)	Comments
PK	15.60396G	57.05	74.00	-16.95	14.38	3	Vertical	238	1.90	-
AV	15.5886G	44.47	54.00	-9.53	14.40	3	Vertical	238	1.90	-



802.11a_Nss1,(6Mbps)_2TX

08/04/2019

5200MHz_TX

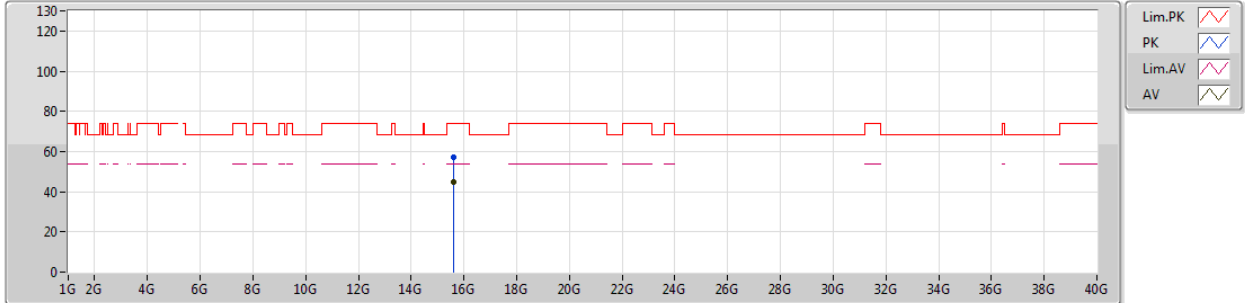

EUT_Z_2TX
Setting 22
01-E-2
Ant Dipole
FSU(100015)

Type	Freq (Hz)	Level (dBuV/m)	Limit (dBuV/m)	Margin (dB)	Factor (dB)	Dist (m)	Condition	Azimuth (°)	Height (m)	Comments
PK	15.61176G	57.25	74.00	-16.75	14.36	3	Horizontal	212	1.82	-
AV	15.61458G	44.55	54.00	-9.45	14.37	3	Horizontal	212	1.82	-

802.11a_Nss1,(6Mbps)_2TX

08/04/2019

5240MHz_TX

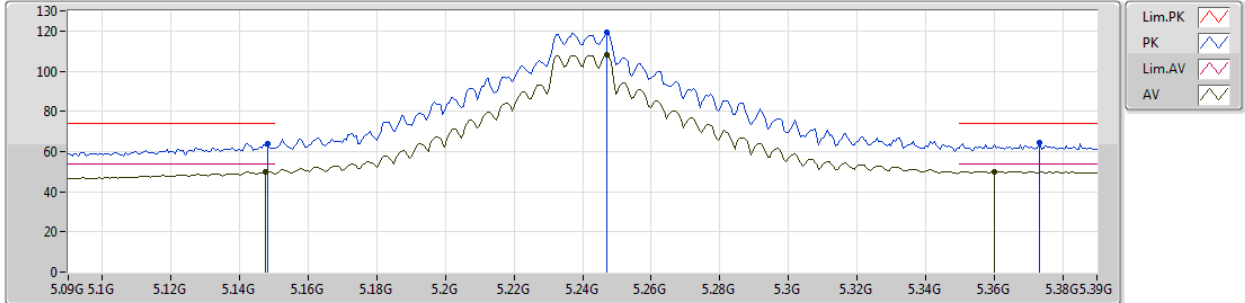

EUT_Z_2TX
Setting 30
01-D-1-10
Ant Dipole
FSU(100015)

Type	Freq (Hz)	Level (dBuV/m)	Limit (dBuV/m)	Margin (dB)	Factor (dB)	Dist (m)	Condition	Azimuth (°)	Height (m)	Comments
PK	5.1482G	64.04	74.00	-9.96	4.25	3	Vertical	292	1.06	-
AV	5.1476G	50.15	54.00	-3.85	4.25	3	Vertical	292	1.06	-
PK	5.2472G	119.37	Inf	-Inf	4.44	3	Vertical	292	1.06	-
AV	5.2472G	107.91	Inf	-Inf	4.44	3	Vertical	292	1.06	-
PK	5.3732G	64.25	74.00	-9.75	4.89	3	Vertical	292	1.06	-
AV	5.36G	50.03	54.00	-3.97	4.85	3	Vertical	292	1.06	-



802.11a_Nss1,(6Mbps)_2TX

08/04/2019

5240MHz_TX

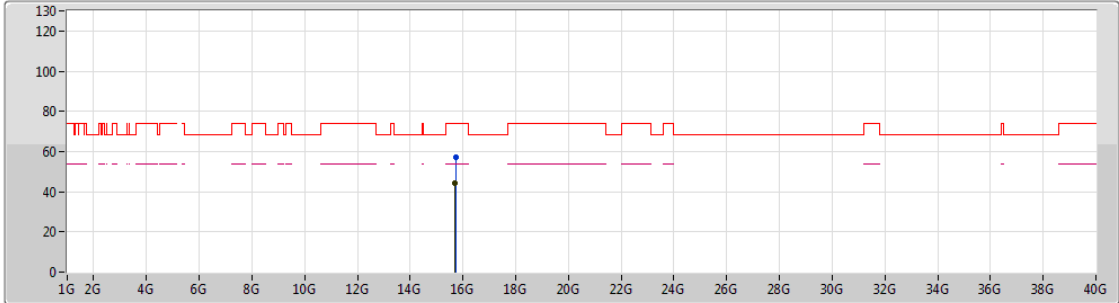

Lim.PK
 PK
 Lim.AV
 AV

EUT_Z_2TX
 Setting 30
 01-E-2
 Ant Dipole
 FSU(100015)

Type	Freq (Hz)	Level (dBuV/m)	Limit (dBuV/m)	Margin (dB)	Factor (dB)	Dist (m)	Condition	Azimuth (°)	Height (m)	Comments
PK	15.71826G	57.18	74.00	-16.82	14.24	3	Vertical	239	1.05	-
AV	15.7155G	43.99	54.00	-10.01	14.24	3	Vertical	239	1.05	-



802.11a_Nss1,(6Mbps)_2TX

08/04/2019

5240MHz_TX

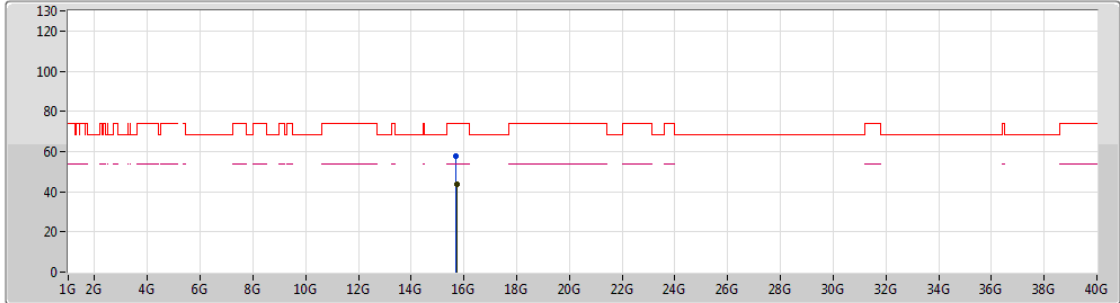

EUT_Z_2TX
 Setting 30
 01-E-2
 Ant Dipole
 FSU(100015)

Type	Freq (Hz)	Level (dBuV/m)	Limit (dBuV/m)	Margin (dB)	Factor (dB)	Dist (m)	Condition	Azimuth (°)	Height (m)	Comments
PK	15.70584G	57.84	74.00	-16.16	14.26	3	Horizontal	337	2.43	-
AV	15.729G	43.95	54.00	-10.05	14.23	3	Horizontal	337	2.43	-



802.11a_Nss1,(6Mbps)_2TX

08/04/2019

5745MHz_TX

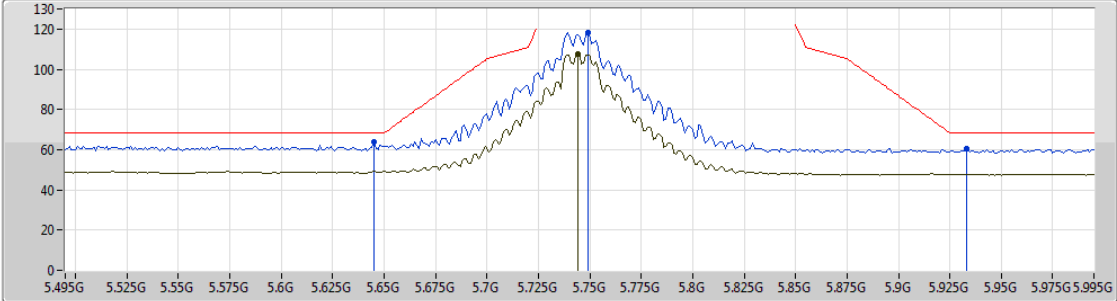

Lim.PK
 PK
 Lim.AV
 AV

EUT_Z_2TX
 Setting 30
 01-D-1-10
 Ant Dipole
 FSU(100015)

Type	Freq (Hz)	Level (dBuV/m)	Limit (dBuV/m)	Margin (dB)	Factor (dB)	Dist (m)	Condition	Azimuth (°)	Height (m)	Comments
PK	5.645G	63.98	68.20	-4.22	5.68	3	Vertical	358	1.29	-
PK	5.749G	118.19	Inf	-Inf	5.85	3	Vertical	358	1.29	-
AV	5.744G	107.40	Inf	-Inf	5.84	3	Vertical	358	1.29	-
PK	5.933G	60.46	68.20	-7.74	6.85	3	Vertical	358	1.29	-



802.11a_Nss1,(6Mbps)_2TX

08/04/2019

5745MHz_TX

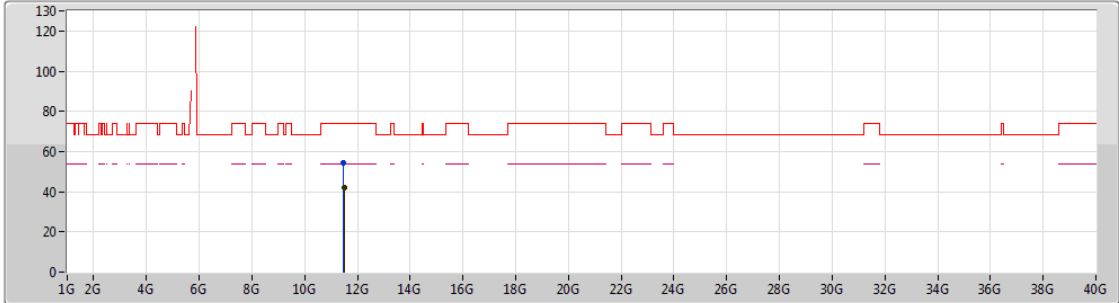

EUT_Z_2TX
 Setting 30
 01-E-2
 Ant Dipole
 FSU(100015)

Type	Freq (Hz)	Level (dBuV/m)	Limit (dBuV/m)	Margin (dB)	Factor (dB)	Dist (m)	Condition	Azimuth (°)	Height (m)	Comments
PK	11.47554G	54.17	74.00	-19.83	11.93	3	Vertical	28	2.41	-
AV	11.48952G	42.18	54.00	-11.82	11.93	3	Vertical	28	2.41	-



802.11a_Nss1,(6Mbps)_2TX

08/04/2019

5745MHz_TX

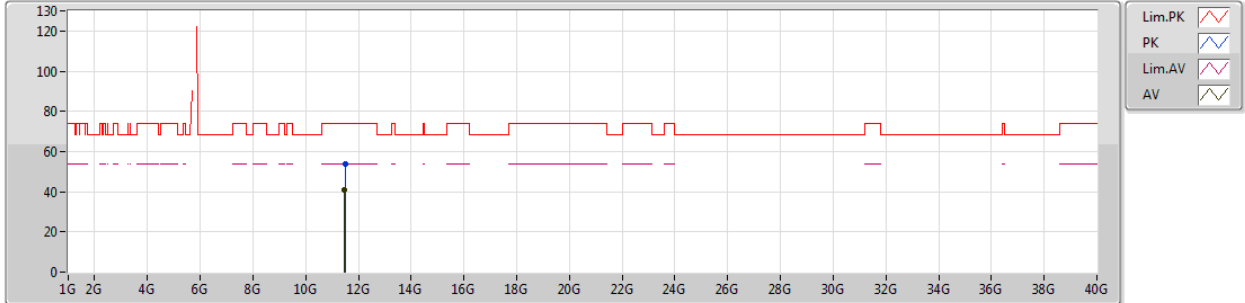

EUT_Z_2TX
 Setting 30
 01-E-2
 Ant Dipole
 FSU(100015)

Type	Freq (Hz)	Level (dBuV/m)	Limit (dBuV/m)	Margin (dB)	Factor (dB)	Dist (m)	Condition	Azimuth (°)	Height (m)	Comments
PK	11.49156G	54.00	74.00	-20.00	11.93	3	Horizontal	270	1.50	-
AV	11.47818G	40.76	54.00	-13.24	11.93	3	Horizontal	270	1.50	-



802.11a_Nss1,(6Mbps)_2TX

08/04/2019

5785MHz_TX

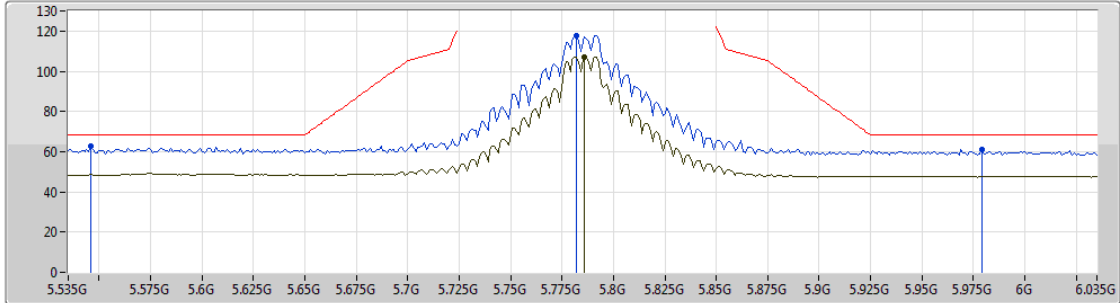

Lim.PK
 PK
 Lim.AV
 AV

EUT_Z_2TX
 Setting 30
 01-D-1-10
 Ant Dipole
 FSU(100015)

Type	Freq (Hz)	Level (dBuV/m)	Limit (dBuV/m)	Margin (dB)	Factor (dB)	Dist (m)	Condition	Azimuth (°)	Height (m)	Comments
PK	5.546G	62.86	68.20	-5.34	5.50	3	Vertical	358	1.43	-
PK	5.782G	117.72	Inf	-Inf	5.91	3	Vertical	358	1.43	-
AV	5.786G	107.30	Inf	-Inf	5.92	3	Vertical	358	1.43	-
PK	5.979G	61.04	68.20	-7.16	7.05	3	Vertical	358	1.43	-



802.11a_Nss1,(6Mbps)_2TX

08/04/2019

5785MHz_TX

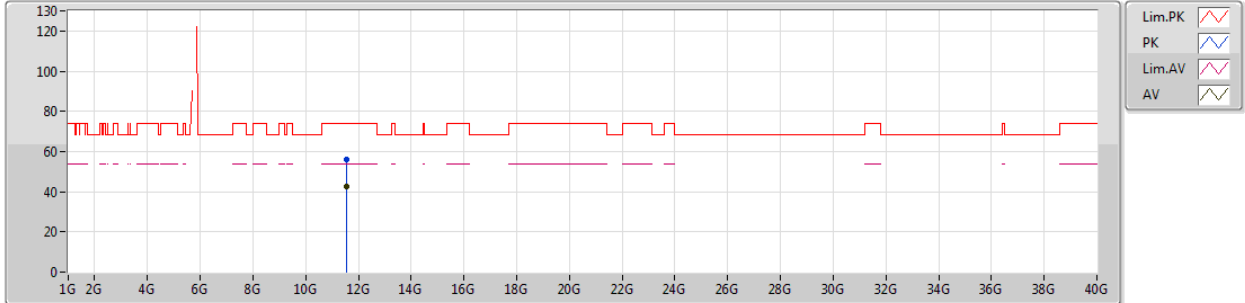

EUT_Z_2TX
 Setting 30
 01-E-2
 Ant Dipole
 FSU(100015)

Type	Freq (Hz)	Level (dBuV/m)	Limit (dBuV/m)	Margin (dB)	Factor (dB)	Dist (m)	Condition	Azimuth (°)	Height (m)	Comments
PK	11.5718G	56.05	74.00	-17.95	11.95	3	Vertical	357	1.80	-
AV	11.57048G	42.39	54.00	-11.61	11.95	3	Vertical	357	1.80	-



802.11a_Nss1,(6Mbps)_2TX

08/04/2019

5785MHz_TX

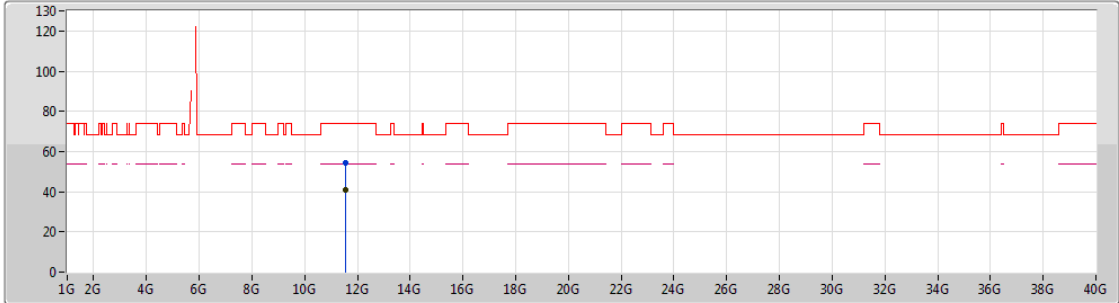

Lim.PK
 PK
 Lim.AV
 AV

EUT_Z_2TX
 Setting 30
 01-E-2
 Ant Dipole
 FSU(100015)

Type	Freq (Hz)	Level (dBuV/m)	Limit (dBuV/m)	Margin (dB)	Factor (dB)	Dist (m)	Condition	Azimuth (°)	Height (m)	Comments
PK	11.56526G	54.57	74.00	-19.43	11.96	3	Horizontal	100	1.44	-
AV	11.57012G	40.64	54.00	-13.36	11.95	3	Horizontal	100	1.44	-



802.11a_Nss1,(6Mbps)_2TX

08/04/2019

5825MHz_TX

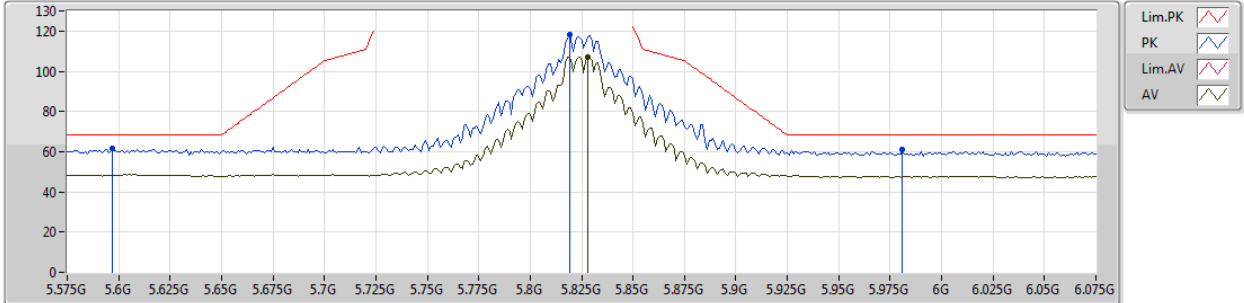

EUT_Z_2TX
 Setting 30
 01-D-1-10
 Ant Dipole
 FSU(100015)

Type	Freq (Hz)	Level (dBuV/m)	Limit (dBuV/m)	Margin (dB)	Factor (dB)	Dist (m)	Condition	Azimuth (°)	Height (m)	Comments
PK	5.597G	61.74	68.20	-6.46	5.63	3	Vertical	358	1.42	-
PK	5.819G	118.04	Inf	-Inf	6.09	3	Vertical	358	1.42	-
AV	5.828G	107.10	Inf	-Inf	6.17	3	Vertical	358	1.42	-
PK	5.981G	60.87	68.20	-7.33	7.06	3	Vertical	358	1.42	-

802.11a_Nss1,(6Mbps)_2TX

08/04/2019

5825MHz_TX

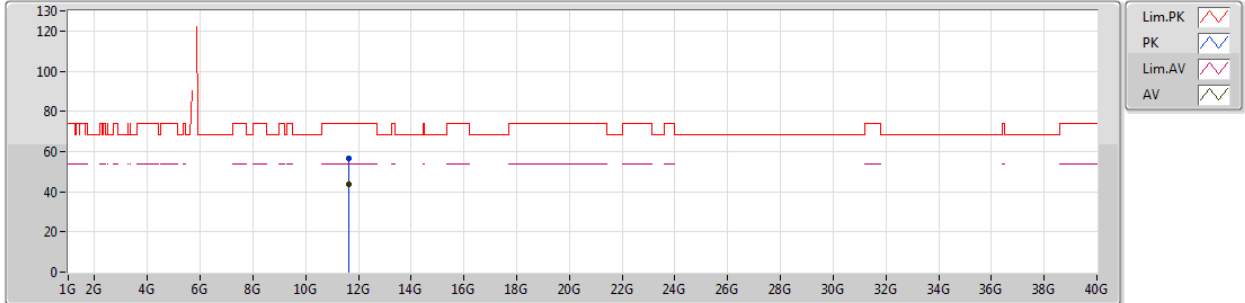

EUT_Z_2TX
Setting 30
01-E-2
Ant Dipole
FSU(100015)

Type	Freq (Hz)	Level (dBuV/m)	Limit (dBuV/m)	Margin (dB)	Factor (dB)	Dist (m)	Condition	Azimuth (°)	Height (m)	Comments
PK	11.65054G	56.62	74.00	-17.38	11.99	3	Vertical	356	2.74	-
AV	11.65G	43.69	54.00	-10.31	11.99	3	Vertical	356	2.74	-



802.11a_Nss1,(6Mbps)_2TX

08/04/2019

5825MHz_TX

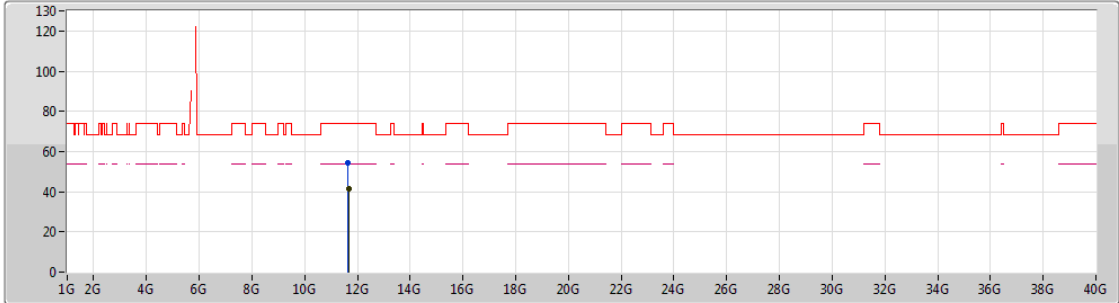

EUT_Z_2TX
 Setting 30
 01-E-2
 Ant Dipole
 FSU(100015)

Type	Freq (Hz)	Level (dBuV/m)	Limit (dBuV/m)	Margin (dB)	Factor (dB)	Dist (m)	Condition	Azimuth (°)	Height (m)	Comments
PK	11.63524G	54.61	74.00	-19.39	11.99	3	Horizontal	177	2.38	-
AV	11.6641G	41.29	54.00	-12.71	12.00	3	Horizontal	177	2.38	-



802.11ac VHT20_Nss1,(MCS0)_2TX

08/04/2019

5180MHz_TX

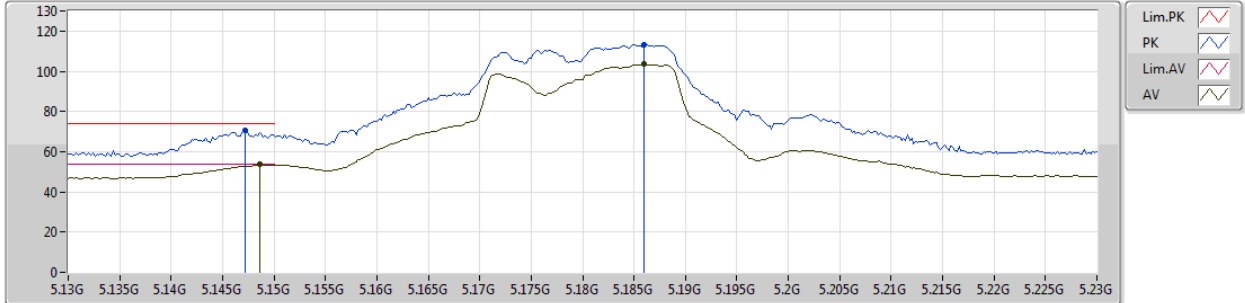

EUT_Z_2TX
Setting 16
01-D-1-10
Ant Dipole
FSU(100015)

Type	Freq (Hz)	Level (dBuV/m)	Limit (dBuV/m)	Margin (dB)	Factor (dB)	Dist (m)	Condition	Azimuth (°)	Height (m)	Comments
PK	5.1472G	70.70	74.00	-3.30	4.25	3	Vertical	63	1.01	-
AV	5.1486G	53.52	54.00	-0.48	4.25	3	Vertical	63	1.01	-
PK	5.186G	113.11	Inf	-Inf	4.27	3	Vertical	63	1.01	-
AV	5.186G	103.39	Inf	-Inf	4.27	3	Vertical	63	1.01	-



802.11ac VHT20_Nss1,(MCS0)_2TX

08/04/2019

5180MHz_TX

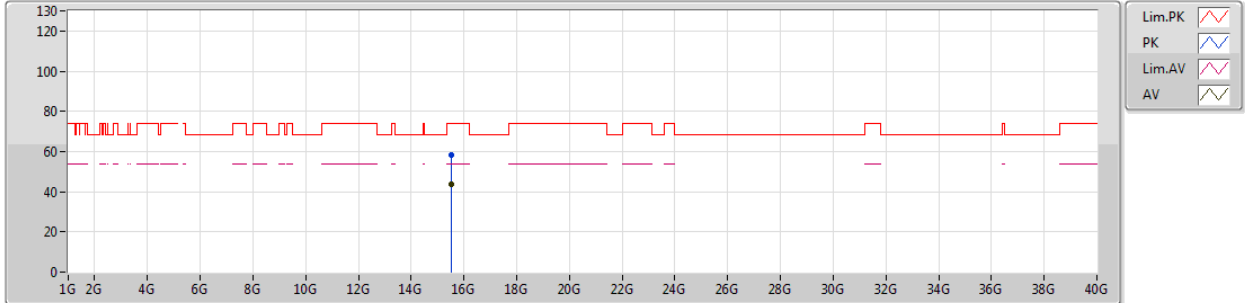

EUT_Z_2TX
Setting 16
01-E-2
Ant Dipole
FSU(100015)

Type	Freq (Hz)	Level (dBuV/m)	Limit (dBuV/m)	Margin (dB)	Factor (dB)	Dist (m)	Condition	Azimuth (°)	Height (m)	Comments
PK	15.53364G	58.14	74.00	-15.86	14.46	3	Vertical	321	1.90	-
AV	15.53886G	43.73	54.00	-10.27	14.47	3	Vertical	321	1.90	-



802.11ac VHT20_Nss1,(MCS0)_2TX

08/04/2019

5180MHz_TX

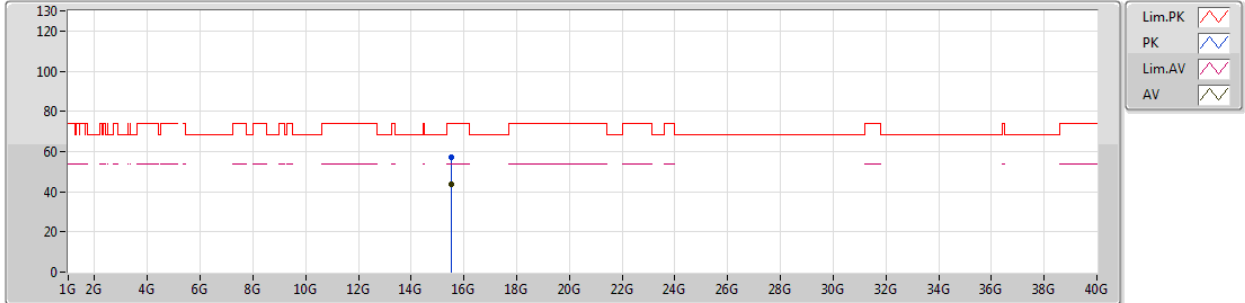

EUT_Z_2TX
Setting 16
01-E-2
Ant Dipole
FSU(100015)

Type	Freq (Hz)	Level (dBuV/m)	Limit (dBuV/m)	Margin (dB)	Factor (dB)	Dist (m)	Condition	Azimuth (°)	Height (m)	Comments
PK	15.5376G	57.13	74.00	-16.87	14.46	3	Horizontal	117	1.50	-
AV	15.53352G	43.71	54.00	-10.29	14.46	3	Horizontal	117	1.50	-



802.11ac VHT20_Nss1,(MCS0)_2TX

08/04/2019

5200MHz_TX

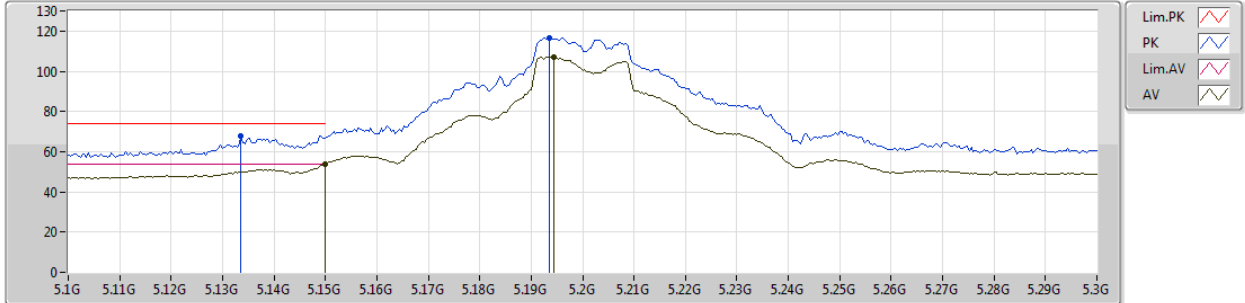

EUT_Z_2TX
 Setting 23
 01-D-1-10
 Ant Dipole
 FSU(100015)

Type	Freq (Hz)	Level (dBuV/m)	Limit (dBuV/m)	Margin (dB)	Factor (dB)	Dist (m)	Condition	Azimuth (°)	Height (m)	Comments
PK	5.1336G	67.92	74.00	-6.08	4.24	3	Vertical	239	1.06	-
AV	5.15G	53.89	54.00	-0.11	4.25	3	Vertical	239	1.06	-
PK	5.1936G	116.61	Inf	-Inf	4.26	3	Vertical	239	1.06	-
AV	5.1944G	107.24	Inf	-Inf	4.26	3	Vertical	239	1.06	-



802.11ac VHT20_Nss1,(MCS0)_2TX

08/04/2019

5200MHz_TX

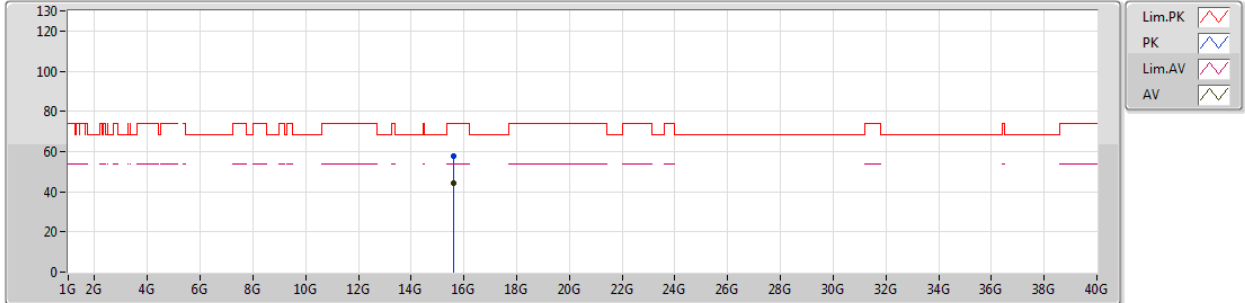

EUT_Z_2TX
Setting 23
01-E-2
Ant Dipole
FSU(100015)

Type	Freq (Hz)	Level (dBuV/m)	Limit (dBuV/m)	Margin (dB)	Factor (dB)	Dist (m)	Condition	Azimuth (°)	Height (m)	Comments
PK	15.59748G	57.53	74.00	-16.47	14.39	3	Vertical	272	2.22	-
AV	15.59772G	44.42	54.00	-9.58	14.39	3	Vertical	272	2.22	-



802.11ac VHT20_Nss1,(MCS0)_2TX

08/04/2019

5200MHz_TX

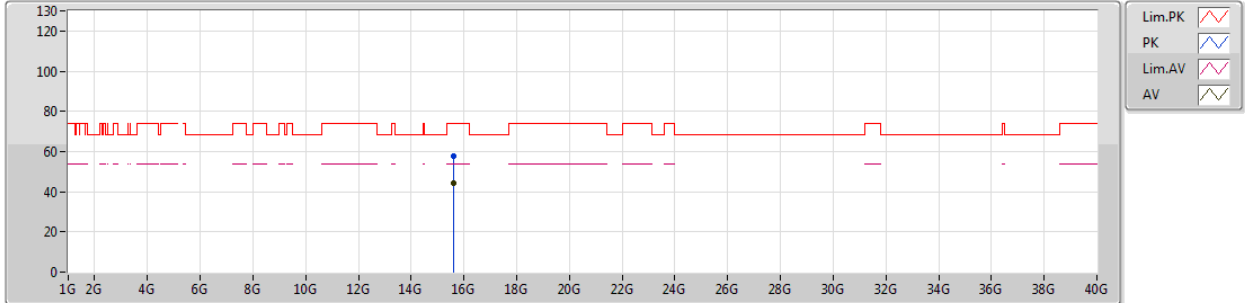

EUT_Z_2TX
Setting 23
01-E-2
Ant Dipole
FSU(100015)

Type	Freq (Hz)	Level (dBuV/m)	Limit (dBuV/m)	Margin (dB)	Factor (dB)	Dist (m)	Condition	Azimuth (°)	Height (m)	Comments
PK	15.606G	57.49	74.00	-16.51	14.38	3	Horizontal	123	2.01	-
AV	15.59982G	44.32	54.00	-9.68	14.39	3	Horizontal	123	2.01	-

802.11ac VHT20_Nss1,(MCS0)_2TX

08/04/2019

5240MHz_TX

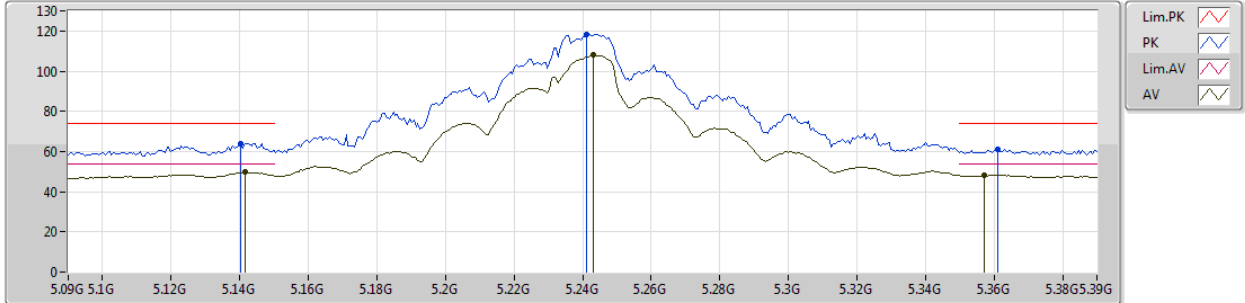

EUT_Z_2TX
Setting 30
01-D-1-10
Ant Dipole
FSU(100015)

Type	Freq (Hz)	Level (dBuV/m)	Limit (dBuV/m)	Margin (dB)	Factor (dB)	Dist (m)	Condition	Azimuth (°)	Height (m)	Comments
PK	5.1404G	64.12	74.00	-9.88	4.24	3	Vertical	117	1.01	-
AV	5.1416G	49.69	54.00	-4.31	4.24	3	Vertical	117	1.01	-
PK	5.2412G	118.44	Inf	-Inf	4.42	3	Vertical	117	1.01	-
AV	5.243G	108.01	Inf	-Inf	4.43	3	Vertical	117	1.01	-
PK	5.3612G	61.06	74.00	-12.94	4.85	3	Vertical	117	1.01	-
AV	5.357G	48.11	54.00	-5.89	4.83	3	Vertical	117	1.01	-



802.11ac VHT20_Nss1,(MCS0)_2TX

08/04/2019

5240MHz_TX

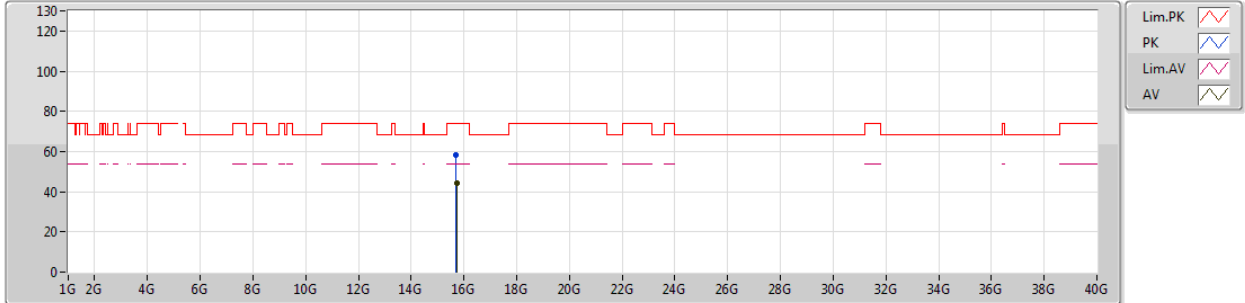

EUT_Z_2TX
Setting 30
01-E-2
Ant Dipole
FSU(100015)

Type	Freq (Hz)	Level (dBuV/m)	Limit (dBuV/m)	Margin (dB)	Factor (dB)	Dist (m)	Condition	Azimuth (°)	Height (m)	Comments
PK	15.70722G	58.18	74.00	-15.82	14.25	3	Vertical	1	2.98	-
AV	15.73104G	44.25	54.00	-9.75	14.23	3	Vertical	1	2.98	-



802.11ac VHT20_Nss1,(MCS0)_2TX

08/04/2019

5240MHz_TX

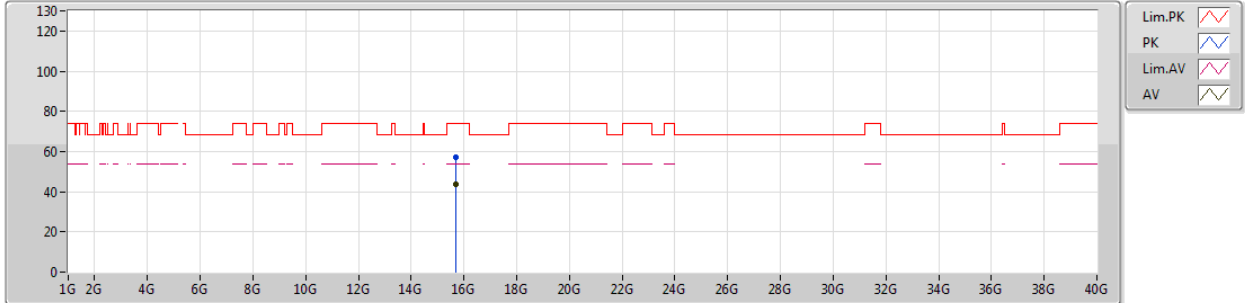

EUT_Z_2TX
 Setting 30
 01-E-2
 Ant Dipole
 FSU(100015)

Type	Freq (Hz)	Level (dBuV/m)	Limit (dBuV/m)	Margin (dB)	Factor (dB)	Dist (m)	Condition	Azimuth (°)	Height (m)	Comments
PK	15.70662G	57.12	74.00	-16.88	14.25	3	Horizontal	257	1.50	-
AV	15.71364G	43.95	54.00	-10.05	14.25	3	Horizontal	257	1.50	-

802.11ac VHT20_Nss1,(MCS0)_2TX

08/04/2019

5745MHz_TX

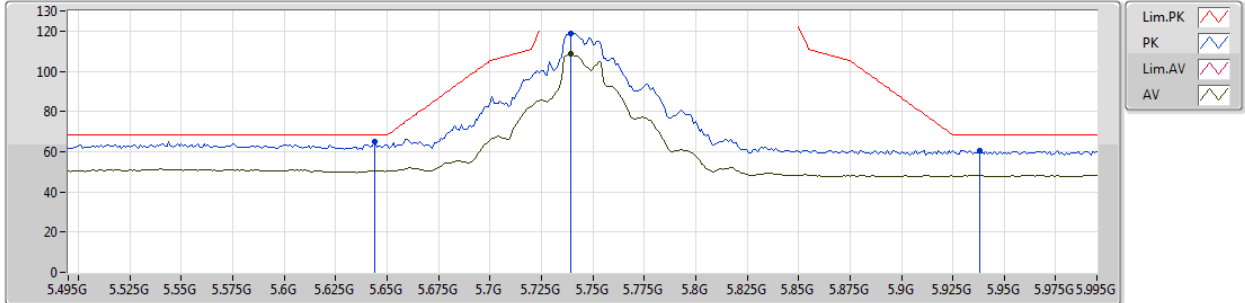

EUT_Z_2TX
Setting 30
01-D-1-10
Ant Dipole
FSU(100015)

Type	Freq (Hz)	Level (dBuV/m)	Limit (dBuV/m)	Margin (dB)	Factor (dB)	Dist (m)	Condition	Azimuth (°)	Height (m)	Comments
PK	5.644G	65.11	68.20	-3.09	5.68	3	Vertical	293	1.11	-
PK	5.739G	118.61	Inf	-Inf	5.83	3	Vertical	293	1.11	-
AV	5.739G	108.62	Inf	-Inf	5.83	3	Vertical	293	1.11	-
PK	5.938G	60.72	68.20	-7.48	6.86	3	Vertical	293	1.11	-



802.11ac VHT20_Nss1,(MCS0)_2TX

08/04/2019

5745MHz_TX

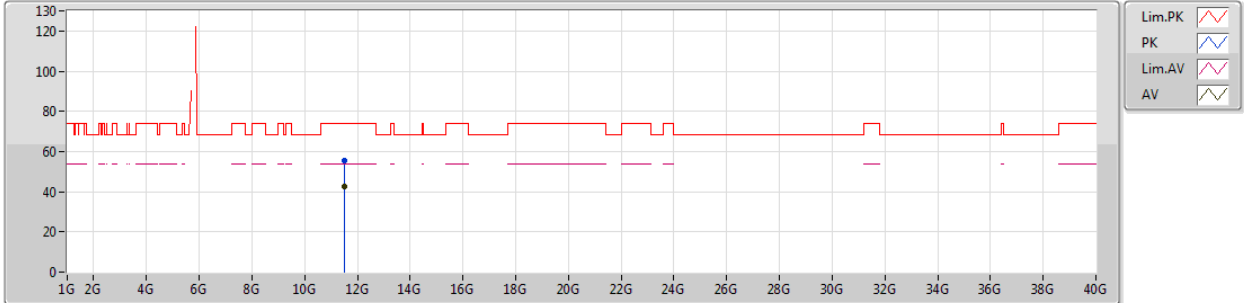

EUT_Z_2TX
 Setting 30
 01-E-2
 Ant Dipole
 FSU(100015)

Type	Freq (Hz)	Level (dBuV/m)	Limit (dBuV/m)	Margin (dB)	Factor (dB)	Dist (m)	Condition	Azimuth (°)	Height (m)	Comments
PK	11.49444G	55.39	74.00	-18.61	11.93	3	Vertical	267	2.28	-
AV	11.49042G	42.43	54.00	-11.57	11.93	3	Vertical	267	2.28	-



802.11ac VHT20_Nss1,(MCS0)_2TX

08/04/2019

5745MHz_TX

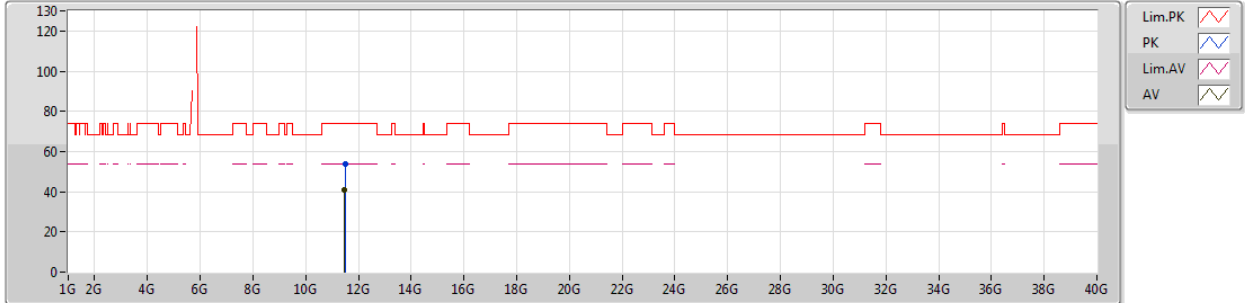

EUT_Z_2TX
 Setting 30
 01-E-2
 Ant Dipole
 FSU(100015)

Type	Freq (Hz)	Level (dBuV/m)	Limit (dBuV/m)	Margin (dB)	Factor (dB)	Dist (m)	Condition	Azimuth (°)	Height (m)	Comments
PK	11.49918G	53.64	74.00	-20.36	11.93	3	Horizontal	65	2.96	-
AV	11.4837G	40.73	54.00	-13.27	11.93	3	Horizontal	65	2.96	-



802.11ac VHT20_Nss1,(MCS0)_2TX

08/04/2019

5785MHz_TX

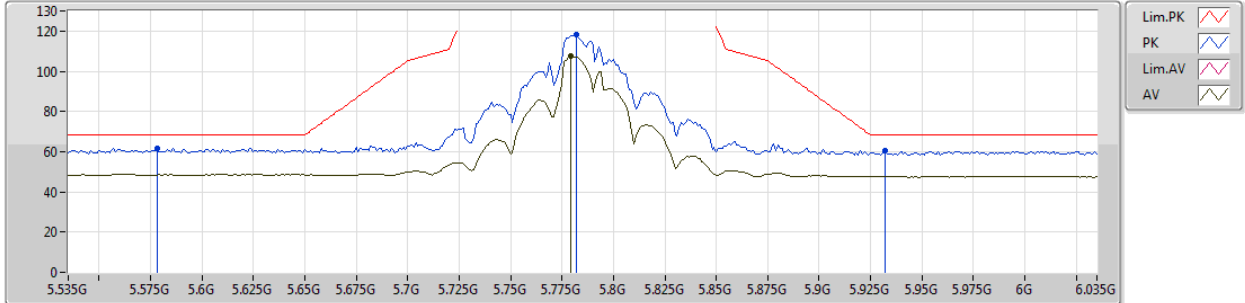

EUT_Z_2TX
 Setting 30
 01-D-1-10
 Ant Dipole
 FSU(100015)

Type	Freq (Hz)	Level (dBuV/m)	Limit (dBuV/m)	Margin (dB)	Factor (dB)	Dist (m)	Condition	Azimuth (°)	Height (m)	Comments
PK	5.578G	61.87	68.20	-6.33	5.58	3	Vertical	358	1.47	-
PK	5.782G	118.08	Inf	-Inf	5.91	3	Vertical	358	1.47	-
AV	5.779G	107.67	Inf	-Inf	5.91	3	Vertical	358	1.47	-
PK	5.932G	60.33	68.20	-7.87	6.84	3	Vertical	358	1.47	-



802.11ac VHT20_Nss1,(MCS0)_2TX

08/04/2019

5785MHz_TX

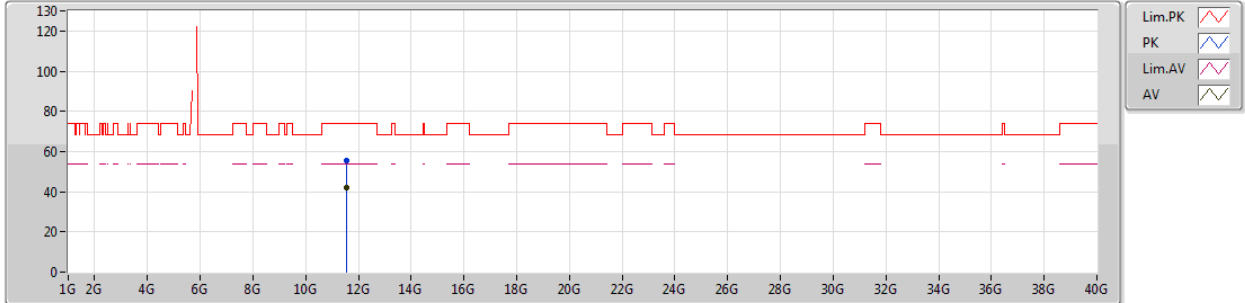

EUT_Z_2TX
 Setting 30
 01-E-2
 Ant Dipole
 FSU(100015)

Type	Freq (Hz)	Level (dBuV/m)	Limit (dBuV/m)	Margin (dB)	Factor (dB)	Dist (m)	Condition	Azimuth (°)	Height (m)	Comments
PK	11.568862G	55.71	74.00	-18.29	11.95	3	Vertical	36	2.30	-
AV	11.568886G	42.29	54.00	-11.71	11.95	3	Vertical	36	2.30	-



802.11ac VHT20_Nss1,(MCS0)_2TX

08/04/2019

5785MHz_TX

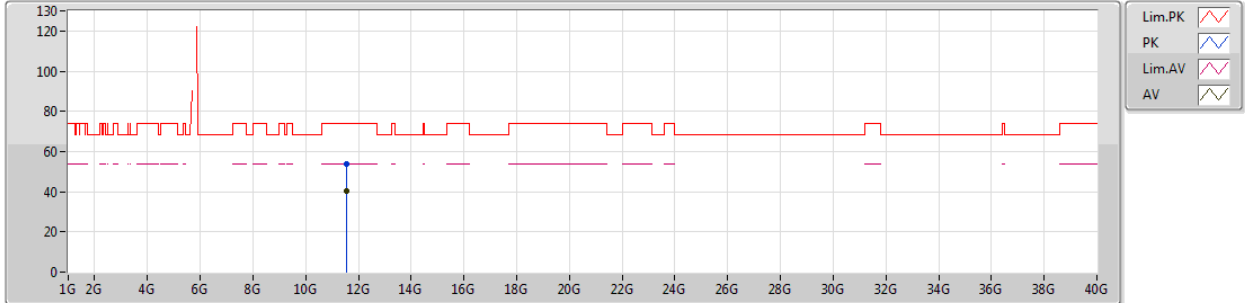

EUT_Z_2TX
 Setting 30
 01-E-2
 Ant Dipole
 FSU(100015)

Type	Freq (Hz)	Level (dBuV/m)	Limit (dBuV/m)	Margin (dB)	Factor (dB)	Dist (m)	Condition	Azimuth (°)	Height (m)	Comments
PK	11.56706G	53.60	74.00	-20.40	11.95	3	Horizontal	92	2.97	-
AV	11.57G	40.62	54.00	-13.38	11.95	3	Horizontal	92	2.97	-



802.11ac VHT20_Nss1,(MCS0)_2TX

08/04/2019

5825MHz_TX

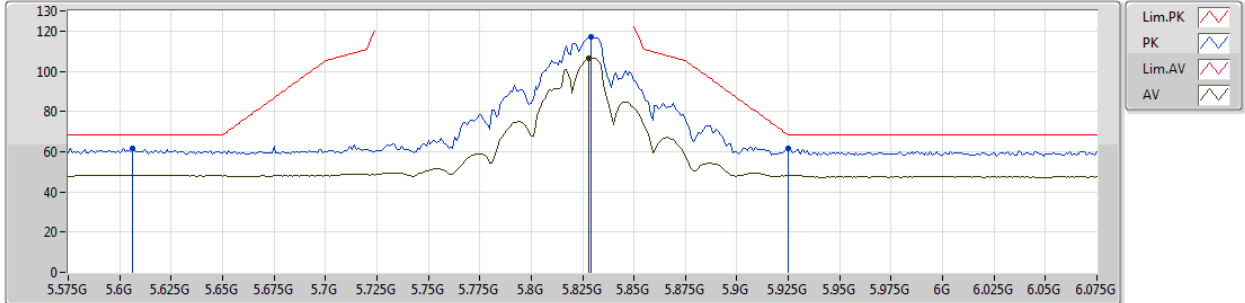

EUT_Z_2TX
 Setting 30
 01-D-1-10
 Ant Dipole
 FSU(100015)

Type	Freq (Hz)	Level (dBuV/m)	Limit (dBuV/m)	Margin (dB)	Factor (dB)	Dist (m)	Condition	Azimuth (°)	Height (m)	Comments
PK	5.606G	61.72	68.20	-6.48	5.65	3	Vertical	358	1.50	-
PK	5.829G	117.17	Inf	-Inf	6.17	3	Vertical	358	1.50	-
AV	5.828G	106.70	Inf	-Inf	6.17	3	Vertical	358	1.50	-
PK	5.925G	61.66	68.20	-6.54	6.81	3	Vertical	358	1.50	-



802.11ac VHT20_Nss1,(MCS0)_2TX

08/04/2019

5825MHz_TX

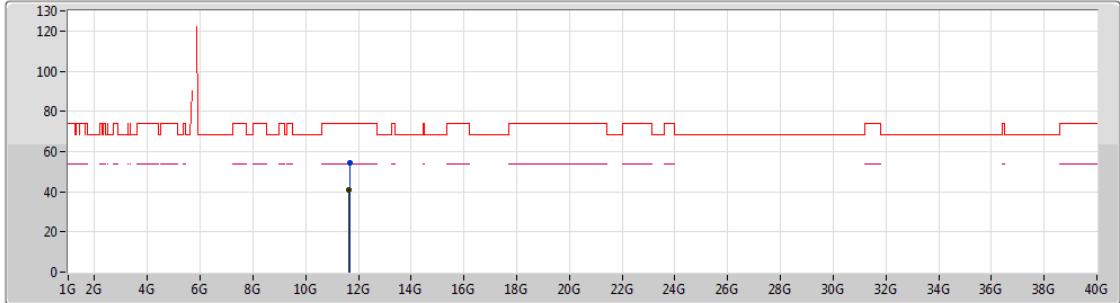

Lim.PK
 PK
 Lim.AV
 AV

EUT_Z_2TX
 Setting 30
 01-E-2
 Ant Dipole
 FSU(100015)

Type	Freq (Hz)	Level (dBuV/m)	Limit (dBuV/m)	Margin (dB)	Factor (dB)	Dist (m)	Condition	Azimuth (°)	Height (m)	Comments
PK	11.65936G	54.26	74.00	-19.74	12.00	3	Vertical	139	1.22	-
AV	11.64142G	40.75	54.00	-13.25	11.99	3	Vertical	139	1.22	-

802.11ac VHT20_Nss1,(MCS0)_2TX

08/04/2019

5825MHz_TX

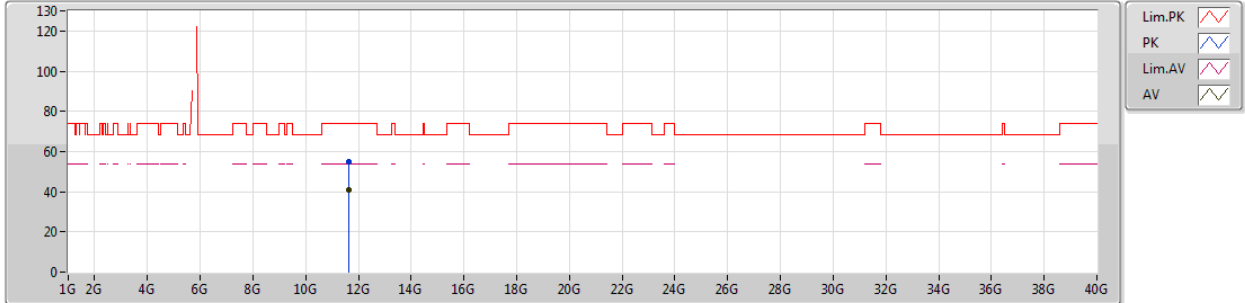

EUT_Z_2TX
Setting 30
01-E-2
Ant Dipole
FSU(100015)

Type	Freq (Hz)	Level (dBuV/m)	Limit (dBuV/m)	Margin (dB)	Factor (dB)	Dist (m)	Condition	Azimuth (°)	Height (m)	Comments
PK	11.6479G	54.89	74.00	-19.11	11.99	3	Horizontal	210	1.50	-
AV	11.6476G	40.99	54.00	-13.01	11.99	3	Horizontal	210	1.50	-

802.11ac VHT40_Nss1,(MCS0)_2TX

08/04/2019

5190MHz_TX

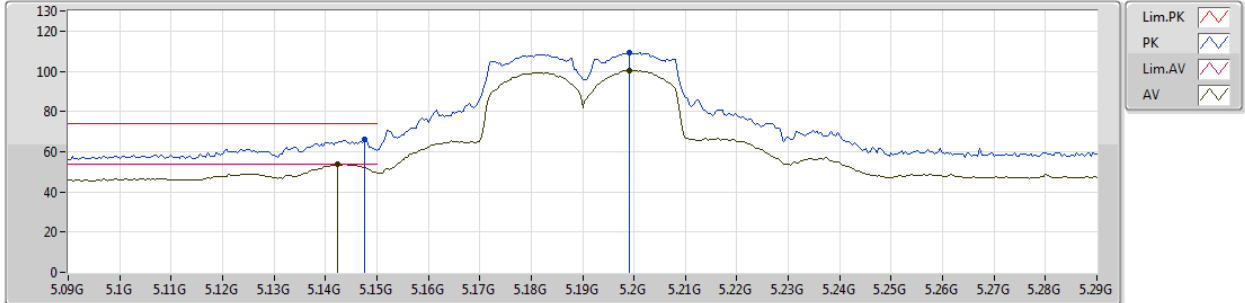

EUT_Z_2TX
Setting 16
01-D-1-10
Ant Dipole
FSU(100015)

Type	Freq (Hz)	Level (dBuV/m)	Limit (dBuV/m)	Margin (dB)	Factor (dB)	Dist (m)	Condition	Azimuth (°)	Height (m)	Comments
PK	5.1476G	66.28	74.00	-7.72	4.25	3	Vertical	294	1.01	-
AV	5.1424G	53.97	54.00	-0.03	4.24	3	Vertical	294	1.01	-
PK	5.1992G	109.16	Inf	-Inf	4.27	3	Vertical	294	1.01	-
AV	5.1992G	100.35	Inf	-Inf	4.27	3	Vertical	294	1.01	-



802.11ac VHT40_Nss1,(MCS0)_2TX

08/04/2019

5190MHz_TX

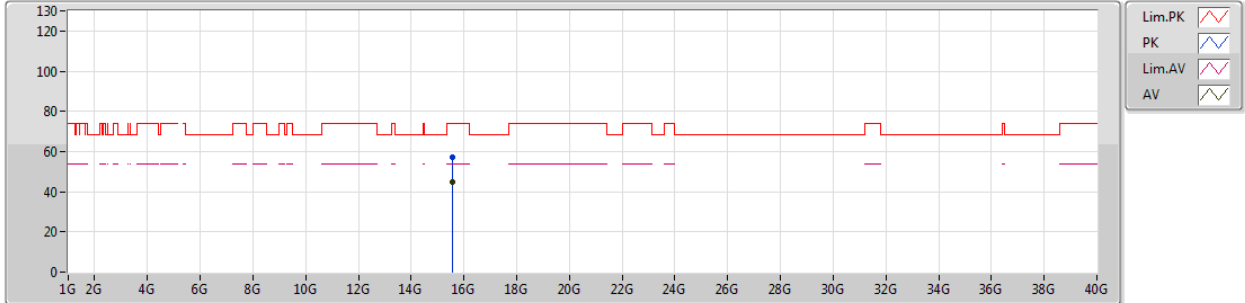

EUT_Z_2TX
Setting 16
01-E-2
Ant Dipole
FSU(100015)

Type	Freq (Hz)	Level (dBuV/m)	Limit (dBuV/m)	Margin (dB)	Factor (dB)	Dist (m)	Condition	Azimuth (°)	Height (m)	Comments
PK	15.55833G	57.07	74.00	-16.93	14.44	3	Vertical	162	1.16	-
AV	15.55788G	44.69	54.00	-9.31	14.44	3	Vertical	162	1.16	-



802.11ac VHT40_Nss1,(MCS0)_2TX

08/04/2019

5190MHz_TX

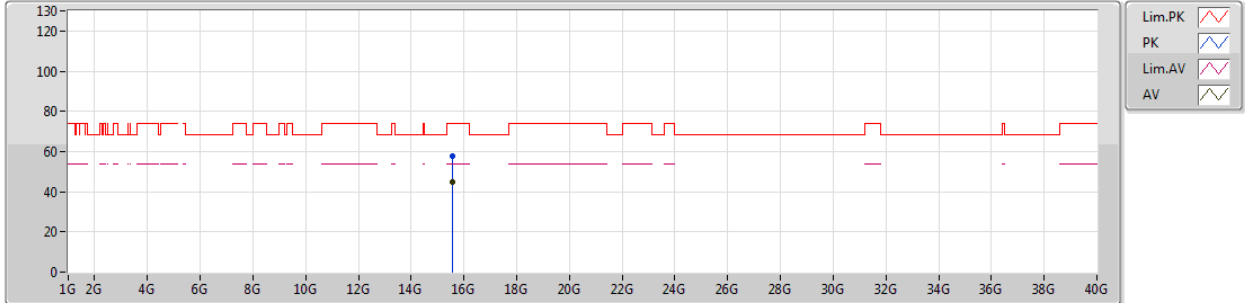

EUT_Z_2TX
Setting 16
01-E-2
Ant Dipole
FSU(100015)

Type	Freq (Hz)	Level (dBuV/m)	Limit (dBuV/m)	Margin (dB)	Factor (dB)	Dist (m)	Condition	Azimuth (°)	Height (m)	Comments
PK	15.56004G	57.50	74.00	-16.50	14.43	3	Horizontal	293	1.72	-
AV	15.56028G	44.67	54.00	-9.33	14.43	3	Horizontal	293	1.72	-



802.11ac VHT40_Nss1,(MCS0)_2TX

08/04/2019

5230MHz_TX

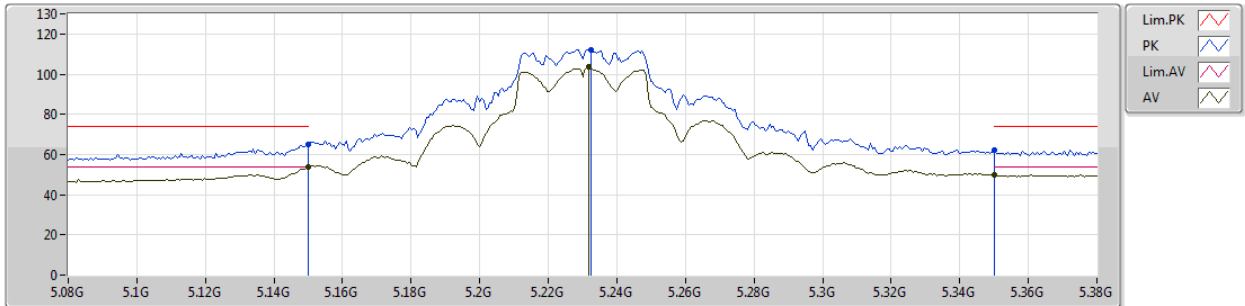

EUT_Z_2TX
 Setting 20.5
 01-D-1-10
 Ant Dipole
 FSU(100015)

Type	Freq (Hz)	Level (dBuV/m)	Limit (dBuV/m)	Margin (dB)	Factor (dB)	Dist (m)	Condition	Azimuth (°)	Height (m)	Comments
PK	5.15G	64.87	74.00	-9.13	4.25	3	Vertical	294	1.02	-
AV	5.15G	53.61	54.00	-0.39	4.25	3	Vertical	294	1.02	-
PK	5.2324G	112.01	Inf	-Inf	4.39	3	Vertical	294	1.02	-
AV	5.2318G	103.47	Inf	-Inf	4.39	3	Vertical	294	1.02	-
PK	5.35G	62.20	74.00	-11.80	4.81	3	Vertical	294	1.02	-
AV	5.35G	49.87	54.00	-4.13	4.81	3	Vertical	294	1.02	-



802.11ac VHT40_Nss1,(MCS0)_2TX

08/04/2019

5230MHz_TX

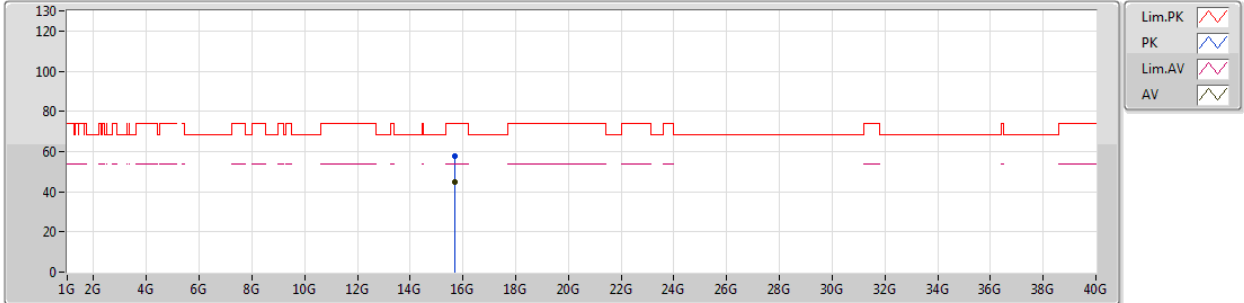

EUT_Z_2TX
 Setting 20.5
 01-E-2
 Ant Dipole
 FSU(100015)

Type	Freq (Hz)	Level (dBuV/m)	Limit (dBuV/m)	Margin (dB)	Factor (dB)	Dist (m)	Condition	Azimuth (°)	Height (m)	Comments
PK	15.70188G	57.74	74.00	-16.26	14.26	3	Vertical	167	1.53	-
AV	15.69G	44.69	54.00	-9.31	14.28	3	Vertical	167	1.53	-



802.11ac VHT40_Nss1,(MCS0)_2TX

08/04/2019

5230MHz_TX

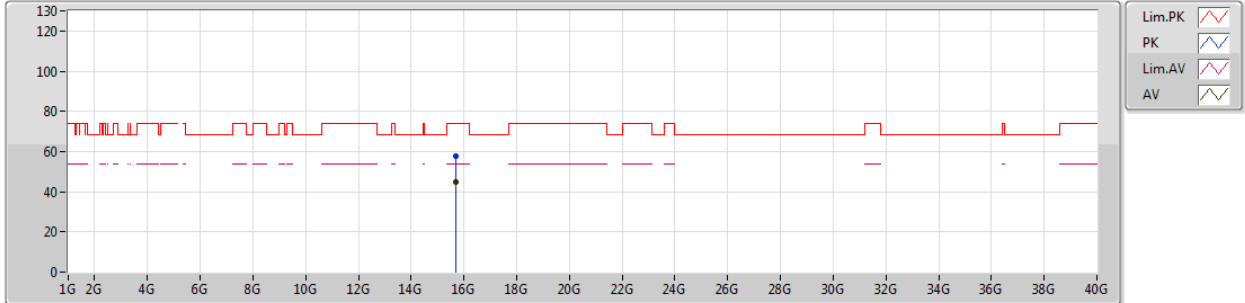

EUT_Z_2TX
 Setting 20.5
 01-E-2
 Ant Dipole
 FSU(100015)

Type	Freq (Hz)	Level (dBuV/m)	Limit (dBuV/m)	Margin (dB)	Factor (dB)	Dist (m)	Condition	Azimuth (°)	Height (m)	Comments
PK	15.68718G	57.62	74.00	-16.38	14.28	3	Horizontal	206	2.22	-
AV	15.69756G	44.82	54.00	-9.18	14.26	3	Horizontal	206	2.22	-



802.11ac VHT40_Nss1,(MCS0)_2TX

08/04/2019

5755MHz_TX

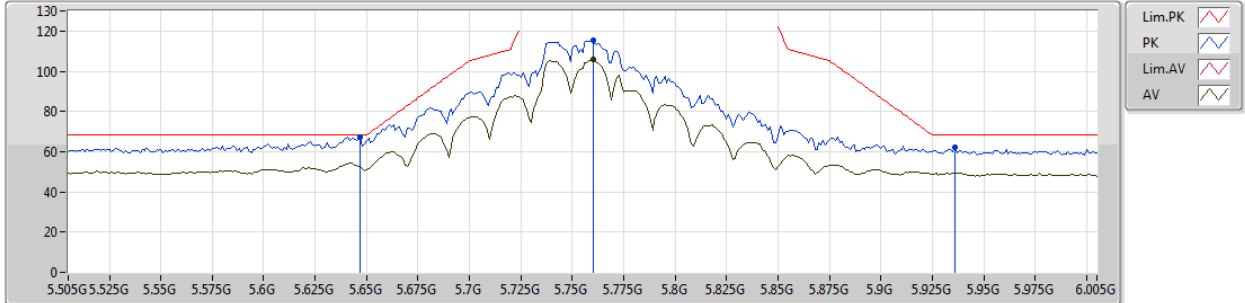

EUT_Z_2TX
 Setting 30
 01-D-1-10
 Ant Dipole
 FSU(100015)

Type	Freq (Hz)	Level (dBuV/m)	Limit (dBuV/m)	Margin (dB)	Factor (dB)	Dist (m)	Condition	Azimuth (°)	Height (m)	Comments
PK	5.647G	67.51	68.20	-0.69	5.69	3	Vertical	357	1.30	-
PK	5.76G	115.27	Inf	-Inf	5.87	3	Vertical	357	1.30	-
AV	5.76G	105.70	Inf	-Inf	5.87	3	Vertical	357	1.30	-
PK	5.936G	61.93	68.20	-6.27	6.86	3	Vertical	357	1.30	-



802.11ac VHT40_Nss1,(MCS0)_2TX

08/04/2019

5755MHz_TX

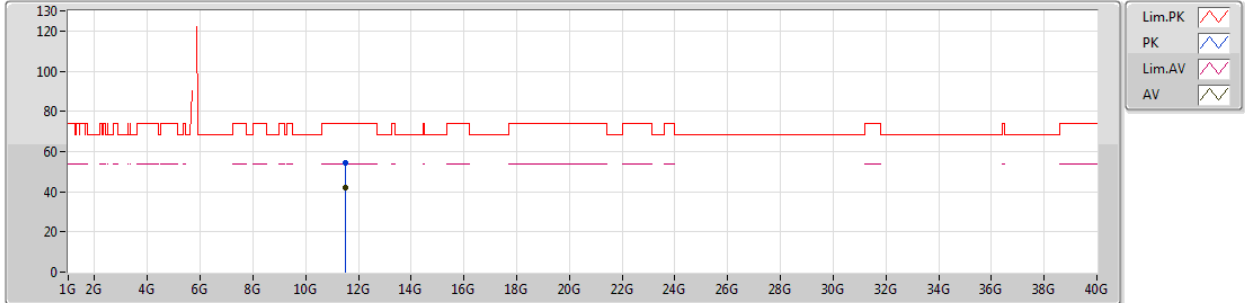

EUT_Z_2TX
 Setting 30
 01-E-2
 Ant Dipole
 FSU(100015)

Type	Freq (Hz)	Level (dBuV/m)	Limit (dBuV/m)	Margin (dB)	Factor (dB)	Dist (m)	Condition	Azimuth (°)	Height (m)	Comments
PK	11.5145G	54.40	74.00	-19.60	11.93	3	Vertical	357	1.72	-
AV	11.51174G	41.75	54.00	-12.25	11.93	3	Vertical	357	1.72	-



802.11ac VHT40_Nss1,(MCS0)_2TX

08/04/2019

5755MHz_TX

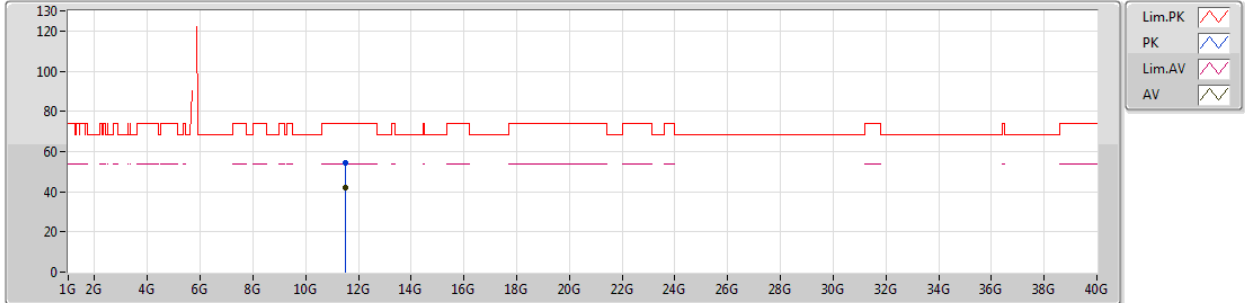

EUT_Z_2TX
 Setting 30
 01-E-2
 Ant Dipole
 FSU(100015)

Type	Freq (Hz)	Level (dBuV/m)	Limit (dBuV/m)	Margin (dB)	Factor (dB)	Dist (m)	Condition	Azimuth (°)	Height (m)	Comments
PK	11.51168G	54.22	74.00	-19.78	11.93	3	Horizontal	336	1.64	-
AV	11.51252G	41.96	54.00	-12.04	11.93	3	Horizontal	336	1.64	-



802.11ac VHT40_Nss1,(MCS0)_2TX

08/04/2019

5795MHz_TX

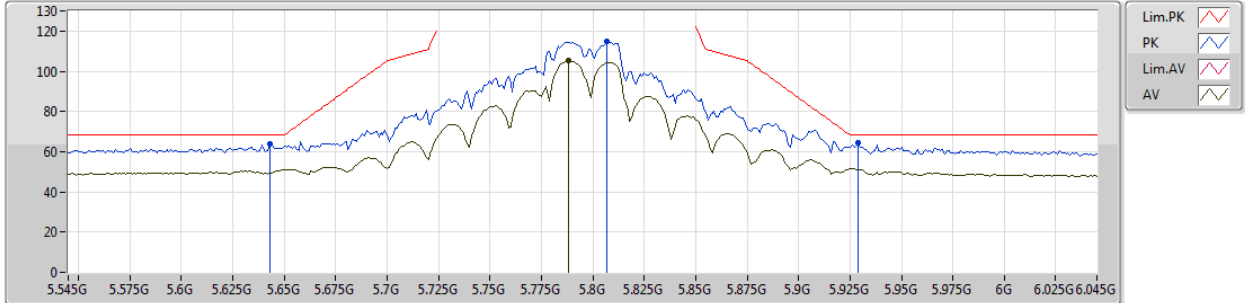

EUT_Z_2TX
 Setting 30
 01-D-1-10
 Ant Dipole
 FSU(100015)

Type	Freq (Hz)	Level (dBuV/m)	Limit (dBuV/m)	Margin (dB)	Factor (dB)	Dist (m)	Condition	Azimuth (°)	Height (m)	Comments
PK	5.643G	63.82	68.20	-4.38	5.68	3	Vertical	357	1.27	-
PK	5.807G	114.68	Inf	-Inf	6.01	3	Vertical	357	1.27	-
AV	5.788G	105.23	Inf	-Inf	5.94	3	Vertical	357	1.27	-
PK	5.929G	64.67	68.20	-3.53	6.83	3	Vertical	357	1.27	-

802.11ac VHT40_Nss1,(MCS0)_2TX

08/04/2019

5795MHz_TX

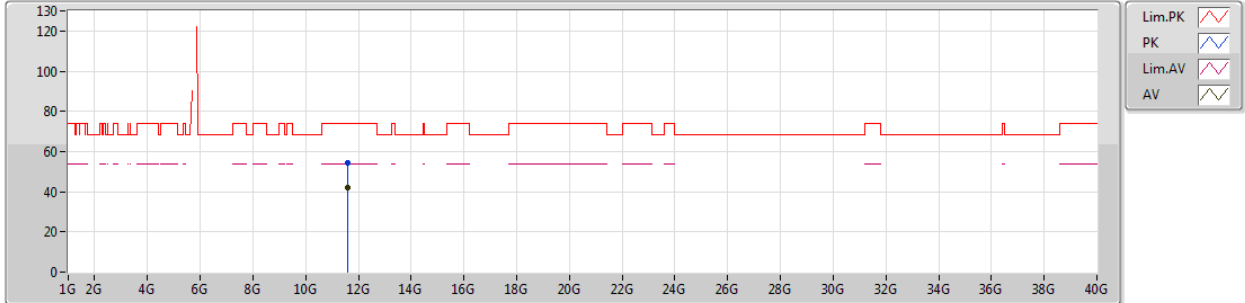

EUT_Z_2TX
Setting 30
01-E-2
Ant Dipole
FSU(100015)

Type	Freq (Hz)	Level (dBuV/m)	Limit (dBuV/m)	Margin (dB)	Factor (dB)	Dist (m)	Condition	Azimuth (°)	Height (m)	Comments
PK	11.58274G	54.60	74.00	-19.40	11.97	3	Vertical	320	2.29	-
AV	11.5861G	42.25	54.00	-11.75	11.97	3	Vertical	320	2.29	-

802.11ac VHT40_Nss1,(MCS0)_2TX

08/04/2019

5795MHz_TX

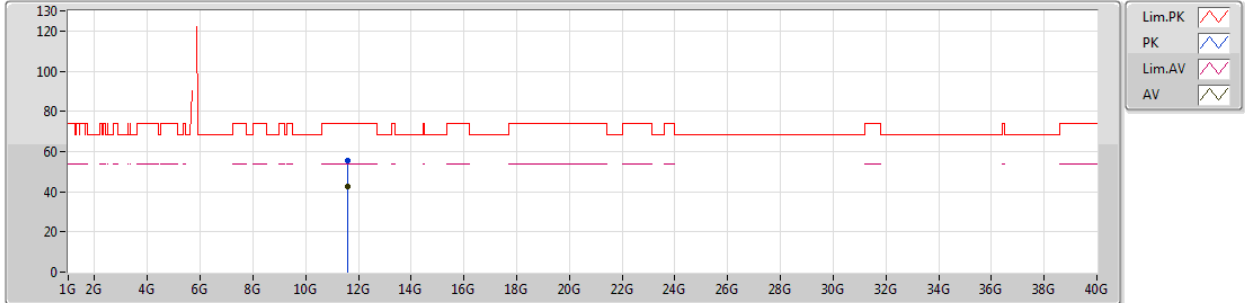

EUT_Z_2TX
Setting 30
01-E-2
Ant Dipole
FSU(100015)

Type	Freq (Hz)	Level (dBuV/m)	Limit (dBuV/m)	Margin (dB)	Factor (dB)	Dist (m)	Condition	Azimuth (°)	Height (m)	Comments
PK	11.60458G	55.32	74.00	-18.68	11.98	3	Horizontal	351	1.66	-
AV	11.5864G	42.33	54.00	-11.67	11.97	3	Horizontal	351	1.66	-

802.11ac VHT80_Nss1,(MCS0)_2TX

08/04/2019

5210MHz_TX

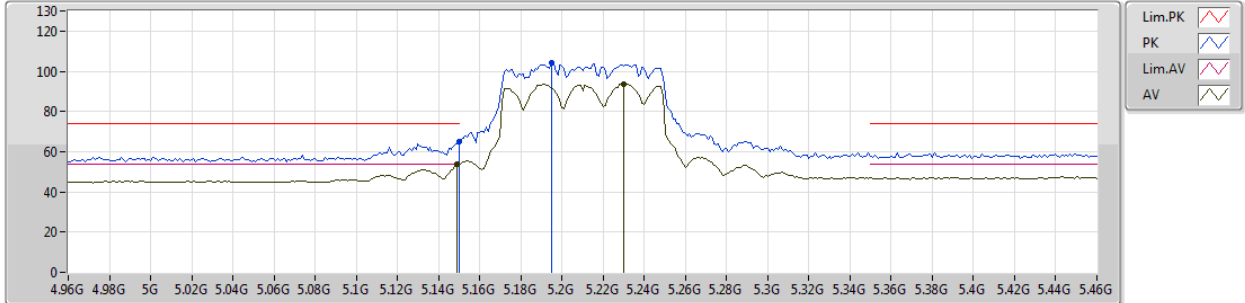

EUT_Z_2TX
 Setting 13.5
 01-D-1-10
 Ant Dipole
 FSU(100015)

Type	Freq (Hz)	Level (dBuV/m)	Limit (dBuV/m)	Margin (dB)	Factor (dB)	Dist (m)	Condition	Azimuth (°)	Height (m)	Comments
PK	5.15G	65.11	74.00	-8.89	4.25	3	Vertical	294	1.00	-
AV	5.149G	53.52	54.00	-0.48	4.25	3	Vertical	294	1.00	-
PK	5.195G	104.09	Inf	-Inf	4.26	3	Vertical	294	1.00	-
AV	5.23G	93.82	Inf	-Inf	4.38	3	Vertical	294	1.00	-





802.11ac VHT80_Nss1,(MCS0)_2TX

08/04/2019

5210MHz_TX

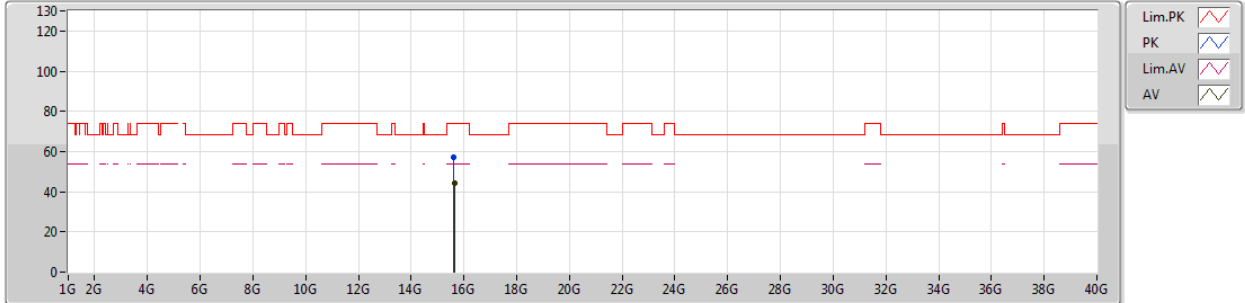

EUT_Z_2TX
 Setting 13.5
 01-E-2
 Ant Dipole
 FSU(100015)

Type	Freq (Hz)	Level (dBuV/m)	Limit (dBuV/m)	Margin (dB)	Factor (dB)	Dist (m)	Condition	Azimuth (°)	Height (m)	Comments
PK	15.61542G	56.96	74.00	-17.04	14.37	3	Horizontal	36	2.03	-
AV	15.63432G	44.44	54.00	-9.56	14.35	3	Horizontal	36	2.03	-



802.11ac VHT80_Nss1,(MCS0)_2TX

08/04/2019

5775MHz_TX

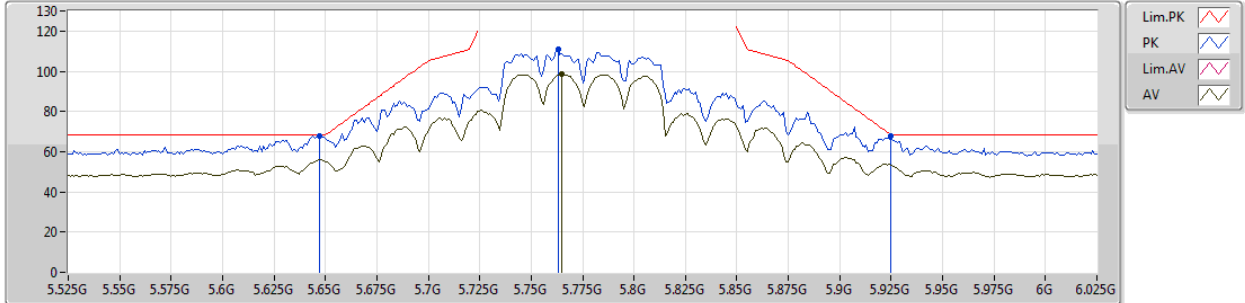

EUT_Z_2TX
Setting 22
01-D-1-10
Ant Dipole
FSU(100015)

Type	Freq (Hz)	Level (dBuV/m)	Limit (dBuV/m)	Margin (dB)	Factor (dB)	Dist (m)	Condition	Azimuth (°)	Height (m)	Comments
PK	5.647G	67.90	68.20	-0.30	5.69	3	Vertical	355	1.50	-
PK	5.763G	110.97	Inf	-Inf	5.89	3	Vertical	355	1.50	-
AV	5.765G	98.64	Inf	-Inf	5.89	3	Vertical	355	1.50	-
PK	5.925G	67.61	68.20	-0.59	6.81	3	Vertical	355	1.50	-



802.11ac VHT80_Nss1,(MCS0)_2TX

08/04/2019

5775MHz_TX

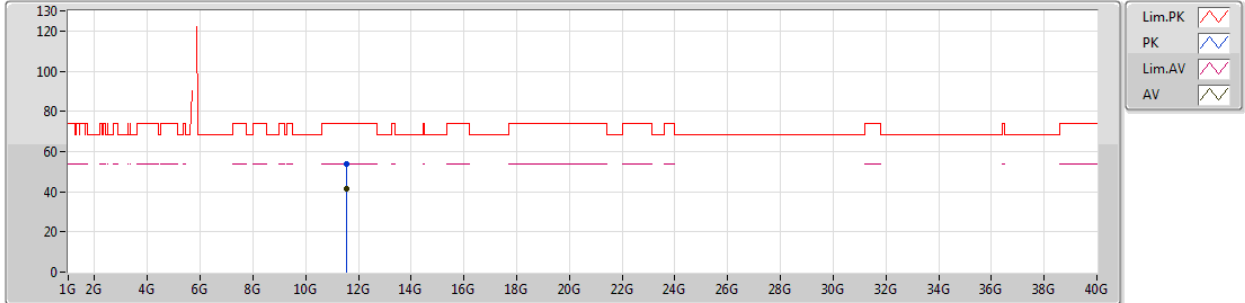

EUT_Z_2TX
 Setting 22
 01-E-2
 Ant Dipole
 FSU(100015)

Type	Freq (Hz)	Level (dBuV/m)	Limit (dBuV/m)	Margin (dB)	Factor (dB)	Dist (m)	Condition	Azimuth (°)	Height (m)	Comments
PK	11.54034G	53.98	74.00	-20.02	11.95	3	Vertical	39	1.50	-
AV	11.5425G	41.51	54.00	-12.49	11.95	3	Vertical	39	1.50	-



802.11ac VHT80_Nss1,(MCS0)_2TX

08/04/2019

5775MHz_TX

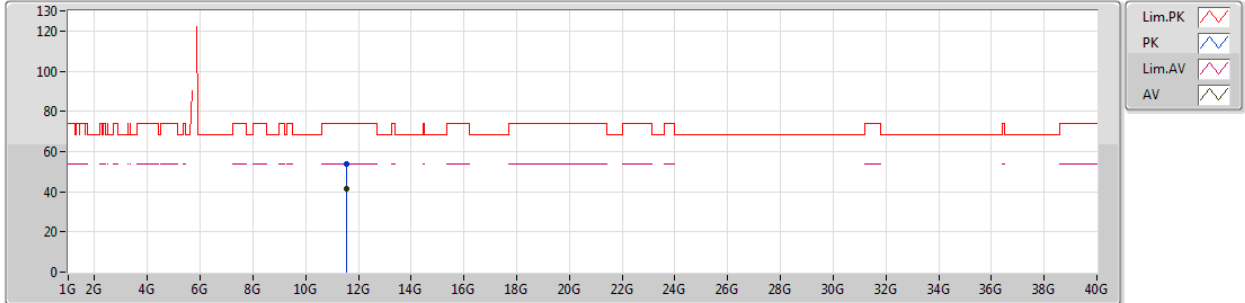

EUT_Z_2TX
Setting 22
01-E-2
Ant Dipole
FSU(100015)

Type	Freq (Hz)	Level (dBuV/m)	Limit (dBuV/m)	Margin (dB)	Factor (dB)	Dist (m)	Condition	Azimuth (°)	Height (m)	Comments
PK	11.54364G	53.72	74.00	-20.28	11.95	3	Horizontal	232	2.16	-
AV	11.54784G	41.40	54.00	-12.60	11.95	3	Horizontal	232	2.16	-

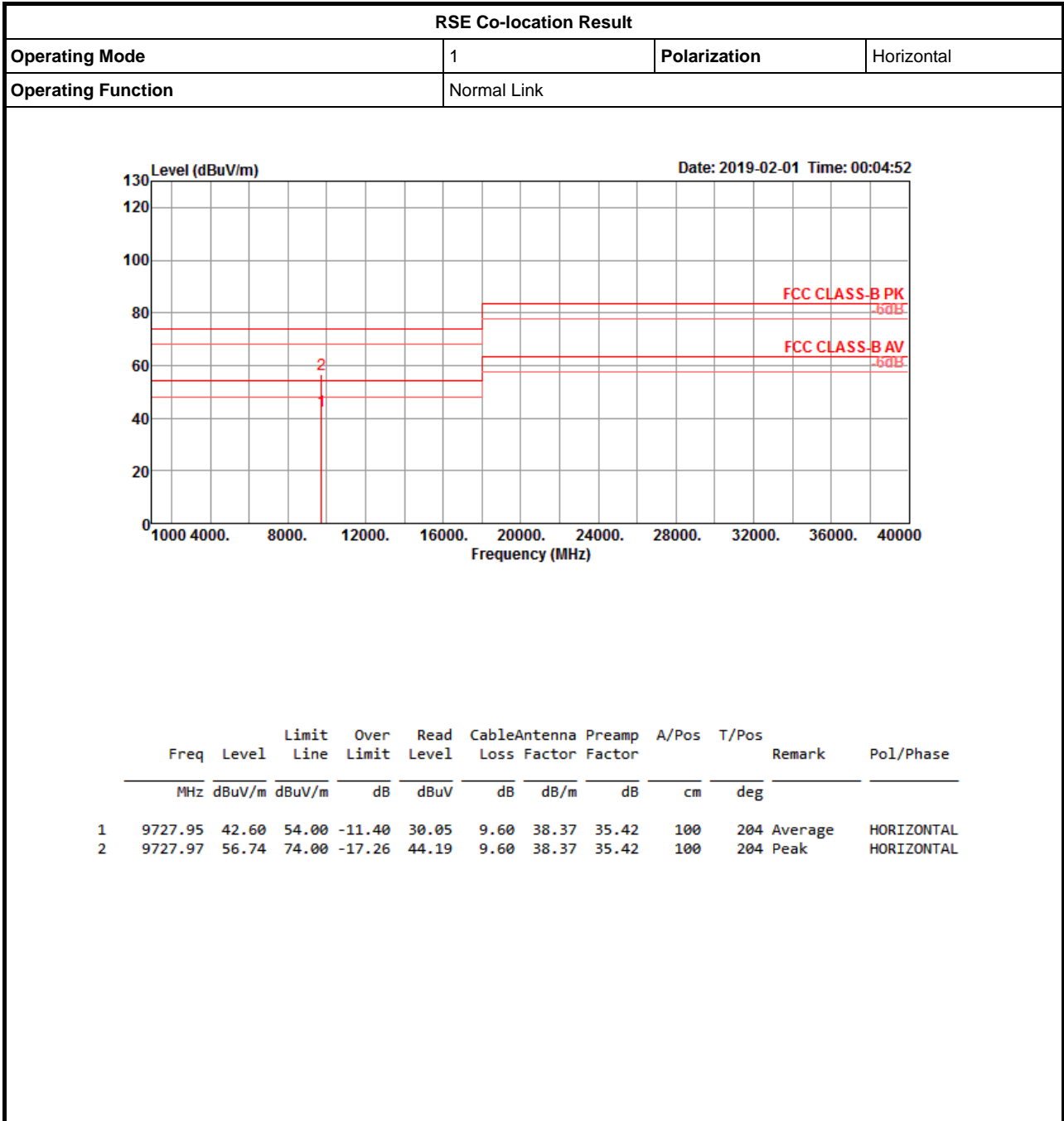



RSE Co-location Result

Appendix F

