



FCC TEST REPORT (15.407)

REPORT NO.: RF140717E01A-1

MODEL NO.: C-65

FCC ID: TOR-C-65

RECEIVED: July 28, 2014

TESTED: July 28 to Aug. 16, 2014

ISSUED: Dec. 19, 2014

APPLICANT: AirTight Networks Inc.

ADDRESS: 339 N Bernardo Ave, Mountain View, CA
94043, United States

ISSUED BY: Bureau Veritas Consumer Products Services
(H.K.) Ltd., Taoyuan Branch Hsin Chu Laboratory

LAB ADDRESS : No. 81-1, Lu Liao Keng, 9th Ling, Wu Lung Tsuen,
Chiung Lin Hsiang, Hsin Chu Hsien 307, Taiwan,
R.O.C.

TEST LOCATION (1): No. 81-1, Lu Liao Keng, 9th Ling, Wu Lung Tsuen,
Chiung Lin Hsiang, Hsin Chu Hsien 307, Taiwan,
R.O.C.

TEST LOCATION (2): No. 49, Ln. 206, Wende Rd., Shangshan Tsuen,
Chiung Lin Hsiang, Hsin Chu Hsien 307, Taiwan,
R.O.C.

This report should not be used by the client to claim product certification, approval, or endorsement by TAF or any government agencies.



This report is for your exclusive use. Any copying or replication of this report to or for any other person or entity, or use of our name or trademark, is permitted only with our prior written permission. This report sets forth our findings solely with respect to the test samples identified herein. The results set forth in this report are not indicative or representative of the quality or characteristics of the lot from which a test sample was taken or any similar or identical product unless specifically and expressly noted. Our report includes all of the tests requested by you and the results thereof based upon the information that you provided to us. You have 60 days from date of issuance of this report to notify us of any material error or omission caused by our negligence, provided, however, that such notice shall be in writing and shall specifically address the issue you wish to raise. A failure to raise such issue within the prescribed time shall constitute your unqualified acceptance of the completeness of this report, the tests conducted and the correctness of the report contents. Unless specific mention, the uncertainty of measurement has been explicitly taken into account to declare the compliance or non-compliance to the specification



Table of Contents

RELEASE CONTROL RECORD	4
1. CERTIFICATION	5
2. SUMMARY OF TEST RESULTS	6
2.1 MEASUREMENT UNCERTAINTY	7
3. GENERAL INFORMATION.....	8
3.1 GENERAL DESCRIPTION OF EUT	8
3.2 DESCRIPTION OF TEST MODES	10
3.2.1 TEST MODE APPLICABILITY AND TESTED CHANNEL DETAIL	11
3.3 GENERAL DESCRIPTION OF APPLIED STANDARDS	13
3.4 DUTY CYCLE OF TEST SIGNAL.....	14
3.5 DESCRIPTION OF SUPPORT UNITS	18
3.6 CONFIGURATION OF SYSTEM UNDER TEST	19
4. TEST TYPES AND RESULTS	21
4.1 CONDUCTED EMISSION MEASUREMENT	21
4.1.1 LIMITS OF CONDUCTED EMISSION MEASUREMENT.....	21
4.1.2 TEST INSTRUMENTS	21
4.1.3 TEST PROCEDURES	22
4.1.4 DEVIATION FROM TEST STANDARD	22
4.1.5 TEST SETUP	22
4.1.6 EUT OPERATING CONDITIONS	23
4.1.7 TEST RESULTS (MODE 1).....	24
4.1.8 TEST RESULTS (MODE 2).....	26
4.2 RADIATED EMISSION AND BANDEDGE MEASUREMENT.....	28
4.2.1 LIMITS OF RADIATED EMISSION AND BANDEDGE MEASUREMENT	28
4.2.2 LIMITS OF UNWANTED EMISSION OUT OF THE RESTRICTED BANDS.....	28
4.2.3 TEST INSTRUMENTS	29
4.2.4 TEST PROCEDURES	31
4.2.5 DEVIATION FROM TEST STANDARD	31
4.2.6 TEST SETUP	32
4.2.7 EUT OPERATING CONDITION	32
4.2.8 TEST RESULTS	33
4.3 TRANSMIT POWER MEASUREMENT.....	55
4.3.1 LIMITS OF TRANSMIT POWER MEASUREMENT	55
4.3.2 TEST INSTRUMENTS	56
4.3.3 TEST PROCEDURE	56
4.3.4 DEVIATION FROM TEST STANDARD	57
4.3.5 TEST SETUP	57
4.3.6 EUT OPERATING CONDITIONS.....	57



4.3.7	TEST RESULTS	58
4.4	PEAK POWER SPECTRAL DENSITY MEASUREMENT	62
4.4.1	LIMITS OF PEAK POWER SPECTRAL DENSITY MEASUREMENT	62
4.4.2	TEST INSTRUMENTS	62
4.4.3	TEST PROCEDURES	62
4.4.4	DEVIATION FROM TEST STANDARD	62
4.4.5	TEST SETUP	63
4.4.6	EUT OPERATING CONDITIONS	63
4.4.7	TEST RESULTS	64
4.5	PEAK POWER EXCURSION MEASUREMENT	67
4.5.1	LIMITS OF PEAK POWER EXCURSION MEASUREMENT	67
4.5.2	TEST INSTRUMENTS	67
4.5.3	TEST PROCEDURE	67
4.5.4	DEVIATION FROM TEST STANDARD	67
4.5.5	TEST SETUP	67
4.5.6	EUT OPERATING CONDITIONS	68
4.5.7	TEST RESULTS	69
4.6	FREQUENCY STABILITY	72
4.6.1	LIMITS OF FREQUENCY STABILITY MEASUREMENT	72
4.6.2	TEST INSTRUMENTS	72
4.6.3	TEST PROCEDURE	72
4.6.4	DEVIATION FROM TEST STANDARD	73
4.6.5	TEST SETUP	73
4.6.6	EUT OPERATING CONDITION	73
4.6.7	TEST RESULTS	74
5.	PHOTOGRAPHS OF THE TEST CONFIGURATION.....	75
6.	INFORMATION ON THE TESTING LABORATORIES	76
7.	APPENDIX A - MODIFICATIONS RECORDERS FOR ENGINEERING CHANGES TO THE EUT BY THE LAB.....	77



A D T

RELEASE CONTROL RECORD

ISSUE NO.	REASON FOR CHANGE	DATE ISSUED
RF140717E01A-1	Original release	Dec. 19, 2014



1. CERTIFICATION

PRODUCT: Access Point / Sensor
BRAND NAME: AirTight
MODEL NO.: C-65
TEST SAMPLE: ENGINEERING SAMPLE
APPLICANT: AirTight Networks Inc.
TESTED: July 28 to Aug. 16, 2014
STANDARDS: FCC Part 15, Subpart E (Section 15.407 Under Old Rule)
ANSI C63.10-2009

The above equipment (Model: C-65) has been tested by **Bureau Veritas Consumer Products Services (H.K.) Ltd., Taoyuan Branch**, and found compliance with the requirement of the above standards. The test record, data evaluation & Equipment Under Test (EUT) configurations represented herein are true and accurate accounts of the measurements of the sample's EMC characteristics under the conditions specified in this report.

Prepared by : Phoenix Huang , **Date:** Dec. 19, 2014
(Phoenix Huang, Specialist)

Approved by : May Chen , **Date:** Dec. 19, 2014
(May Chen, Manager)



2. SUMMARY OF TEST RESULTS

The EUT has been tested according to the following specifications:

APPLIED STANDARD: FCC PART 15, SUBPART E (SECTION 15.407 Under Old Rule)			
STANDARD SECTION	TEST TYPE	RESULT	REMARK
15.407(b)(6)	AC Power Conducted Emission	PASS	Meet the requirement of limit. Minimum passing margin is -9.50dB at 28.68359MHz
15.407(b/1/2/3) (b)(5)	Spurious Emissions	PASS	Meet the requirement of limit. Minimum passing margin is -0.6dB at 15780.00MHz
15.407(a/1/2)	Transmit Power	PASS	Meet the requirement of limit.
15.407(a)(6)	Peak Power Excursion	PASS	Meet the requirement of limit.
15.407(a/1/2)	Peak Power Spectral Density	PASS	Meet the requirement of limit.
15.407(g)	Frequency Stability	PASS	Meet the requirement of limit.
15.203	Antenna Requirement	PASS	Antenna connector is IPEX not a standard connector.

- NOTE:** 1. This report is prepared for FCC Class II change. (Add DFS band: 5250~5350MHz & 5470~5725MHz).
2. The DFS report was recorded in another test report.



A D T

2.1 MEASUREMENT UNCERTAINTY

Where relevant, the following measurement uncertainty levels have been estimated for tests performed on the EUT as specified in CISPR 16-4-2:

This uncertainty represents an expanded uncertainty expressed at approximately the 95% confidence level using a coverage factor of $k=2$.

Measurement	Value
Conducted emissions	2.86 dB
Radiated emissions (30MHz-1GHz)	5.37 dB
Radiated emissions (1GHz -6GHz)	3.72 dB
Radiated emissions (6GHz -18GHz)	4.00 dB
Radiated emissions (18GHz - 40GHz)	4.11 dB



3. GENERAL INFORMATION

3.1 GENERAL DESCRIPTION OF EUT

PRODUCT	Access Point / Sensor
MODEL NO.	C-65
POWER SUPPLY	DC12V from power adapter or DC 48V from PoE
MODULATION TYPE	CCK, DQPSK, DBPSK for DSSS 64QAM, 16QAM, QPSK, BPSK for OFDM 256QAM for OFDM in 11ac mode only
MODULATION TECHNOLOGY	DSSS,OFDM
TRANSFER RATE	802.11b: up to 11Mbps 802.11a / g: up to 54Mbps 802.11n: up to 300Mbps 802.11ac: up to 866.7Mbps
OPERATING FREQUENCY	5.26 ~ 5.32GHz, 5.50 ~ 5.58GHz & 5.66GHz ~ 5.70GHz
NUMBER OF CHANNEL	12 for 802.11a, 802.11n (HT20), 802.11ac (VHT20) 5 for 802.11n (HT40), 802.11ac (VHT40) 2 for 802.11ac (VHT80)
MAXIMUM OUTPUT POWER	802.11a: 155.433mW 802.11ac (VHT20): 156.509mW 802.11ac (VHT40): 231.166mW 802.11ac (VHT80): 97.858mW
ANTENNA TYPE	Please see NOTE
DATA CABLE	NA
I/O PORTS	Refer to user's manual
ASSOCIATED DEVICES	Adapter x 1

Note:

1. This report is prepared for FCC Class II. The difference compared with the Report No.: RF140717E01-1 design is as the following:
 - ◆ Add DFS band <5250~5350MHz & 5470~5725MHz>



2. 2.4GHz and 5GHz technology can transmit at same time.
3. The antennas provided to the EUT, please refer to the following table:

For 2.4G WLAN used								
Ant. No.	Transmitter Circuit	Brand	Part No.	Antenna Gain(dBi) <including cable loss>	Frequency range (MHz ~ MHz)	Antenna Type	Connector Type	Cable Length (mm)
1	Chain (0)	LYNwave	ALA140-05102A-000000	4.42	2412~2483	PCB-Dipole	IPEX	85
2	Chain (1)		ALA140-05102A-000001	4.39				170
For 5G WLAN used								
Ant. No.	Transmitter Circuit	Brand	Part No.	Antenna Gain(dBi) <including cable loss>	Frequency range (MHz ~ MHz)	Antenna Type	Connector Type	Cable Length (mm)
1	Chain (0)	LYNwave	ALA140-091025-000000	4.39	5150~5825	PCB-Dipole	IPEX	70
2	Chain (1)		ALA140-091025-000001	4.84				160

4. The EUT must be supplied with a power adapter as following table:

No	Brand	Model No.	Spec.
1	LEI	MU18-R120150-A1	Input: 100-240V, 0.6A, 50/60Hz Output: 12V, 1.5A DC power cable: 1.53m, unshielded

5. The EUT incorporates a MIMO function without beamforming.

MODULATION MODE	DATA RATE (MCS)	TX & RX CONFIGURATION	
802.11a	6 ~ 54Mbps	2TX (CDD)	2RX
802.11b	1 ~ 11Mbps	2TX (CDD)	2RX
802.11g	6 ~ 54Mbps	2TX (CDD)	2RX
802.11n (HT20) & 802.11n (HT40)	MCS 0~7	2TX (CDD)	2RX
	MCS 8~15	2TX	2RX
802.11ac (VHT20)	MCS0~8 (256QAM) Nss= 1	2TX (CDD)	2RX
	MCS0~8 (256QAM) Nss= 2	2TX	2RX
802.11ac (VHT40) & 802.11ac (VHT80)	MCS0~9 (256QAM) Nss= 1	2TX (CDD)	2RX
	MCS0~9 (256QAM) Nss= 2	2TX	2RX

Note: The modulation and bandwidth are similar for 802.11n mode for 20MHz (40MHz) and 802.11ac mode for 20MHz (40MHz), therefore investigated worst case to representative mode in test report. (Final test mode refer section 3.2.1)

6. The above EUT information was declared by the manufacturer and for more detailed features description, please refer to the manufacturer's specifications or User's Manual.

3.2 DESCRIPTION OF TEST MODES

Operated in 5260 ~ 5320MHz band:

4 channels are provided for 802.11a, 802.11n (HT20), 802.11ac (VHT20):

CHANNEL	FREQUENCY	CHANNEL	FREQUENCY
52	5260 MHz	60	5300 MHz
56	5280 MHz	64	5320 MHz

2 channels are provided for 802.11n (HT40), 802.11ac (VHT40):

CHANNEL	FREQUENCY
54	5270 MHz
62	5310 MHz

1 channel is provided for 802.11ac (VHT80):

CHANNEL	FREQUENCY
58	5290 MHz

Operated in 5470MHz ~ 5600MHz & 5650MHz ~ 5725MHz bands:

8 channels are provided for 802.11a, 802.11n (HT20), 802.11ac (VHT20):

CHANNEL	FREQUENCY	CHANNEL	FREQUENCY
100	5500 MHz	116	5580 MHz
104	5520 MHz	132	5660 MHz
108	5540 MHz	136	5680 MHz
112	5560 MHz	140	5700 MHz

3 channels are provided for 802.11n (HT40), 802.11ac (VHT40):

CHANNEL	FREQUENCY
102	5510 MHz
110	5550 MHz
134	5670 MHz

1 channel is provided for 802.11ac (VHT80):

CHANNEL	FREQUENCY
106	5530 MHz



3.2.1 TEST MODE APPLICABILITY AND TESTED CHANNEL DETAIL

EUT CONFIGURE MODE	APPLICABLE TO				DESCRIPTION
	PLC	RE < 1G	RE ≥ 1G	APCM	
1	√	√	√	√	Adapter Mode
2	√	-	-	-	PoE Mode

Where **PLC**: Power Line Conducted Emission **RE < 1G**: Radiated Emission below 1GHz
RE ≥ 1G: Radiated Emission above 1GHz **APCM**: Antenna Port Conducted Measurement

NOTE: For the original test report: the EUT had been pre-tested on the positioned of each 2 axis. The worst case was found when positioned on **X-plane** (for below 1GHz) and **Y-plane** (for above 1GHz).

POWER LINE CONDUCTED EMISSION TEST:

- Pre-Scan has been conducted to determine the worst-case mode from all possible combinations between available modulations, data rates and antenna ports (if EUT with antenna diversity architecture).
- Following channel(s) was (were) selected for the final test as listed below.

MODE	AVAILABLE CHANNEL	TESTED CHANNEL	MODULATION TECHNOLOGY	MODULATION TYPE	DATA RATE (MBPS)
802.11ac (VHT40)	54 to 134	110	OFDM	BPSK	13.5

RADIATED EMISSION TEST (BELOW 1 GHz):

- Pre-Scan has been conducted to determine the worst-case mode from all possible combinations between available modulations, data rates and antenna ports (if EUT with antenna diversity architecture).
- Following channel(s) was (were) selected for the final test as listed below.

MODE	AVAILABLE CHANNEL	TESTED CHANNEL	MODULATION TECHNOLOGY	MODULATION TYPE	DATA RATE (Mbps)
802.11ac (VHT40)	54 to 134	110	OFDM	BPSK	13.5



RADIATED EMISSION TEST (ABOVE 1 GHz):

- Pre-Scan has been conducted to determine the worst-case mode from all possible combinations between available modulations, data rates and antenna ports (if EUT with antenna diversity architecture).
- Following channel(s) was (were) selected for the final test as listed below.

MODE	AVAILABLE CHANNEL	TESTED CHANNEL	MODULATION TECHNOLOGY	MODULATI ON TYPE	DATA RATE (Mbps)
802.11a	52 to 140	52, 60, 64, 100, 116, 132, 140	OFDM	BPSK	6
802.11ac (VHT20)	52 to 140	52, 60, 64, 100, 116, 132, 140	OFDM	BPSK	6.5
802.11ac (VHT40)	54 to 134	54, 62, 102, 110, 134	OFDM	BPSK	13.5
802.11ac (VHT80)	58 to 106	58, 106	OFDM	BPSK	29.3

ANTENNA PORT CONDUCTED MEASUREMENT:

- Pre-Scan has been conducted to determine the worst-case mode from all possible combinations between available modulations, data rates and antenna ports (if EUT with antenna diversity architecture).
- Following channel(s) was (were) selected for the final test as listed below.

MODE	AVAILABLE CHANNEL	TESTED CHANNEL	MODULATION TECHNOLOGY	MODULATI ON TYPE	DATA RATE (Mbps)
802.11a	52 to 140	52, 60, 64, 100, 116, 132, 140	OFDM	BPSK	6
802.11ac (VHT20)	52 to 140	52, 60, 64, 100, 116, 132, 140	OFDM	BPSK	6.5
802.11ac (VHT40)	54 to 134	54, 62, 102, 110, 134	OFDM	BPSK	13.5
802.11ac (VHT80)	58 to 106	58, 106	OFDM	BPSK	29.3

TEST CONDITION:

APPLICABLE TO	ENVIRONMENTAL CONDITIONS	INPUT POWER	TESTED BY
PLC	30deg. C, 70%RH	120Vac, 60Hz	Mike Hsieh
RE<1G	25deg. C, 65%RH	120Vac, 60Hz	Andy Ho
RE≥1G	26deg. C, 76%RH	120Vac, 60Hz	Garry Chen
APCM	25deg. C, 60%RH	120Vac, 60Hz	Robert Cheng

3.3 GENERAL DESCRIPTION OF APPLIED STANDARDS

The EUT is a RF product. According to the specifications of the manufacturer, it must comply with the requirements of the following standards:

FCC Part 15, Subpart E (15.407 Under Old Rule)

789033 D01 General UNII Test Procedures Old Rules v01r04

662911 D01 Multiple Transmitter Output v02r01

ANSI C63.10-2009

All test items have been performed and recorded as per the above standards.

Note: The EUT has been verified to comply with the requirements of FCC Part 15, Subpart B, Class B (DoC). The test report has been issued separately.

3.4 DUTY CYCLE OF TEST SIGNAL

If duty cycle of test signal is $\geq 98\%$, duty factor is not required.

If duty cycle of test signal is $< 98\%$, duty factor shall be considered.

802.11a

BPSK: Duty cycle = $5.355 \text{ ms} / 5.425 \text{ ms} = 0.987$

QPSK: Duty cycle = $2.687 \text{ ms} / 2.754 \text{ ms} = 0.976$, Duty factor = $10 * \log(1/0.976) = 0.11$

16QAM: Duty cycle = $1.35 \text{ ms} / 1.418 \text{ ms} = 0.952$, Duty factor = $10 * \log(1/0.952) = 0.21$

64QAM: Duty cycle = $0.686 \text{ ms} / 0.748 \text{ ms} = 0.917$, Duty factor = $10 * \log(1/0.917) = 0.38$

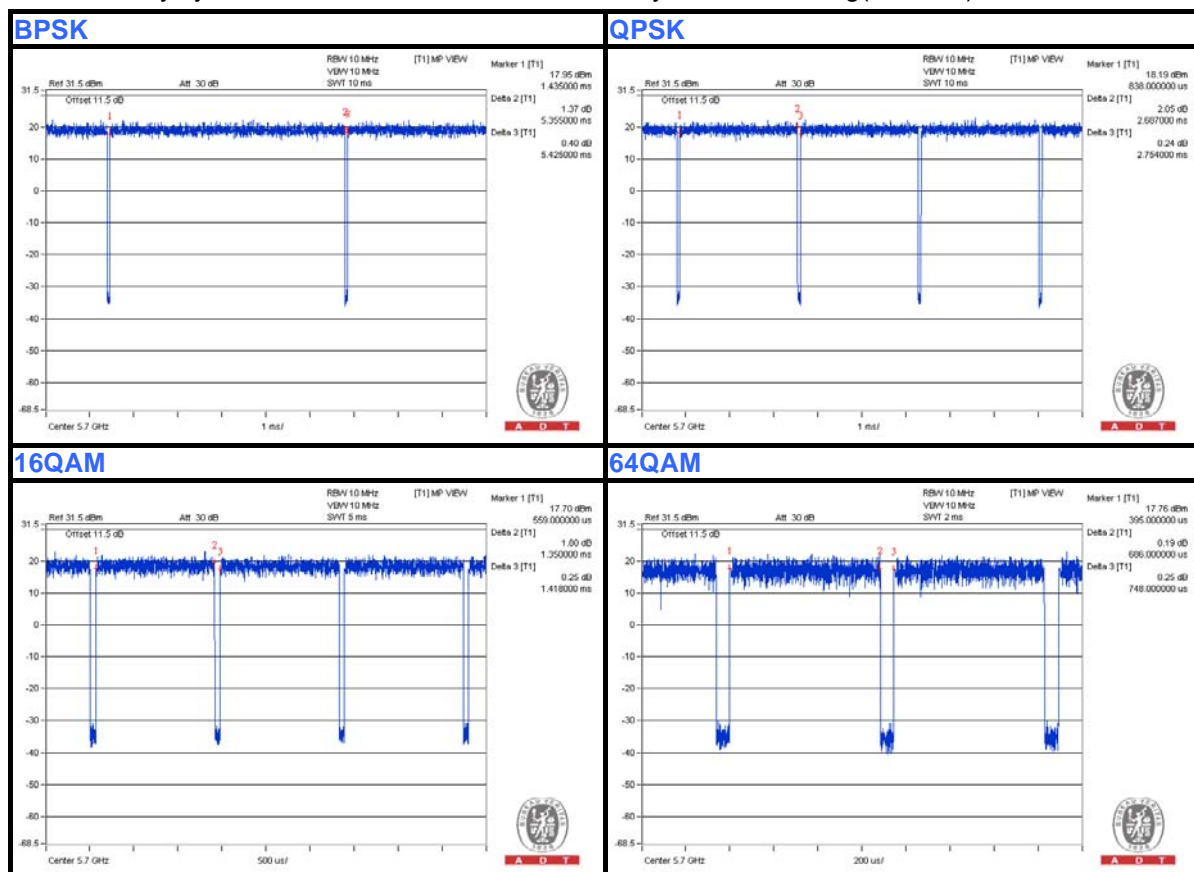

802.11ac (VHT20)

BPSK: Duty cycle = 4.965 ms/5.035 ms = 0.986

QPSK: Duty cycle = 2.508 ms/2.575 ms = 0.974, Duty factor = $10 * \log(1/0.974) = 0.11$

16QAM: Duty cycle = 1.273 ms/1.335 ms = 0.954, Duty factor = $10 * \log(1/0.954) = 0.21$

64QAM: Duty cycle = 0.658 ms/0.719 ms = 0.915, Duty factor = $10 * \log(1/0.915) = 0.39$

256QAM: Duty cycle = 0.451 ms/0.52 ms = 0.867, Duty factor = $10 * \log(1/0.867) = 0.62$

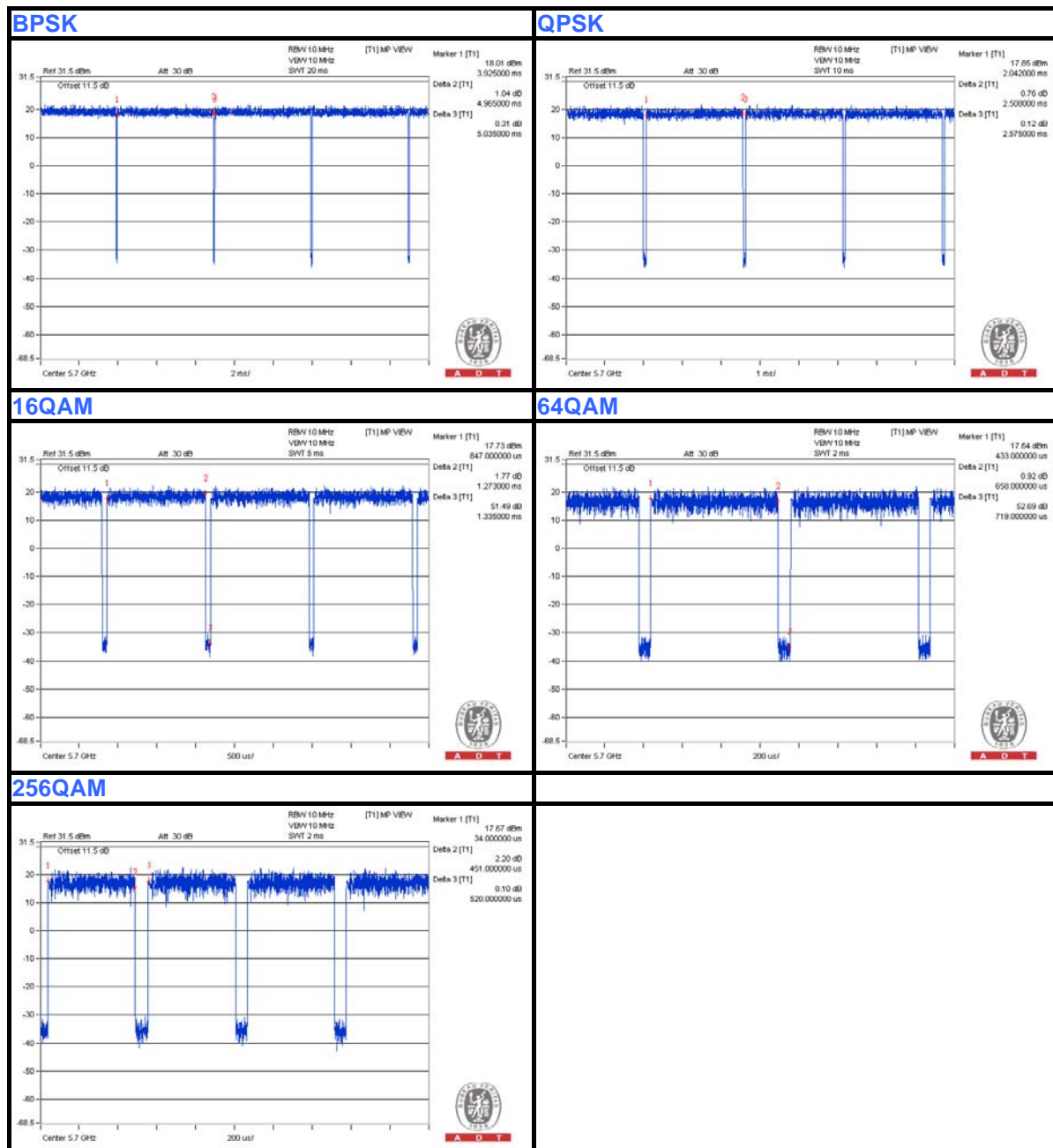



A D T

802.11ac (VHT40)

BPSK: Duty cycle = 2.409 ms/2.482 ms = 0.971, Duty factor = $10 \cdot \log(1/0.971) = 0.13$

QPSK: Duty cycle = 1.226 ms/1.288 ms = 0.952, Duty factor = $10 \cdot \log(1/0.952) = 0.21$

16QAM: Duty cycle = 0.635 ms/0.699 ms = 0.908, Duty factor = $10 \cdot \log(1/0.908) = 0.42$

64QAM: Duty cycle = 0.339 ms/0.402 ms = 0.843, Duty factor = $10 \cdot \log(1/0.843) = 0.74$

256QAM: Duty cycle = 0.239 ms/0.299 ms = 0.799, Duty factor = $10 \cdot \log(1/0.799) = 0.97$

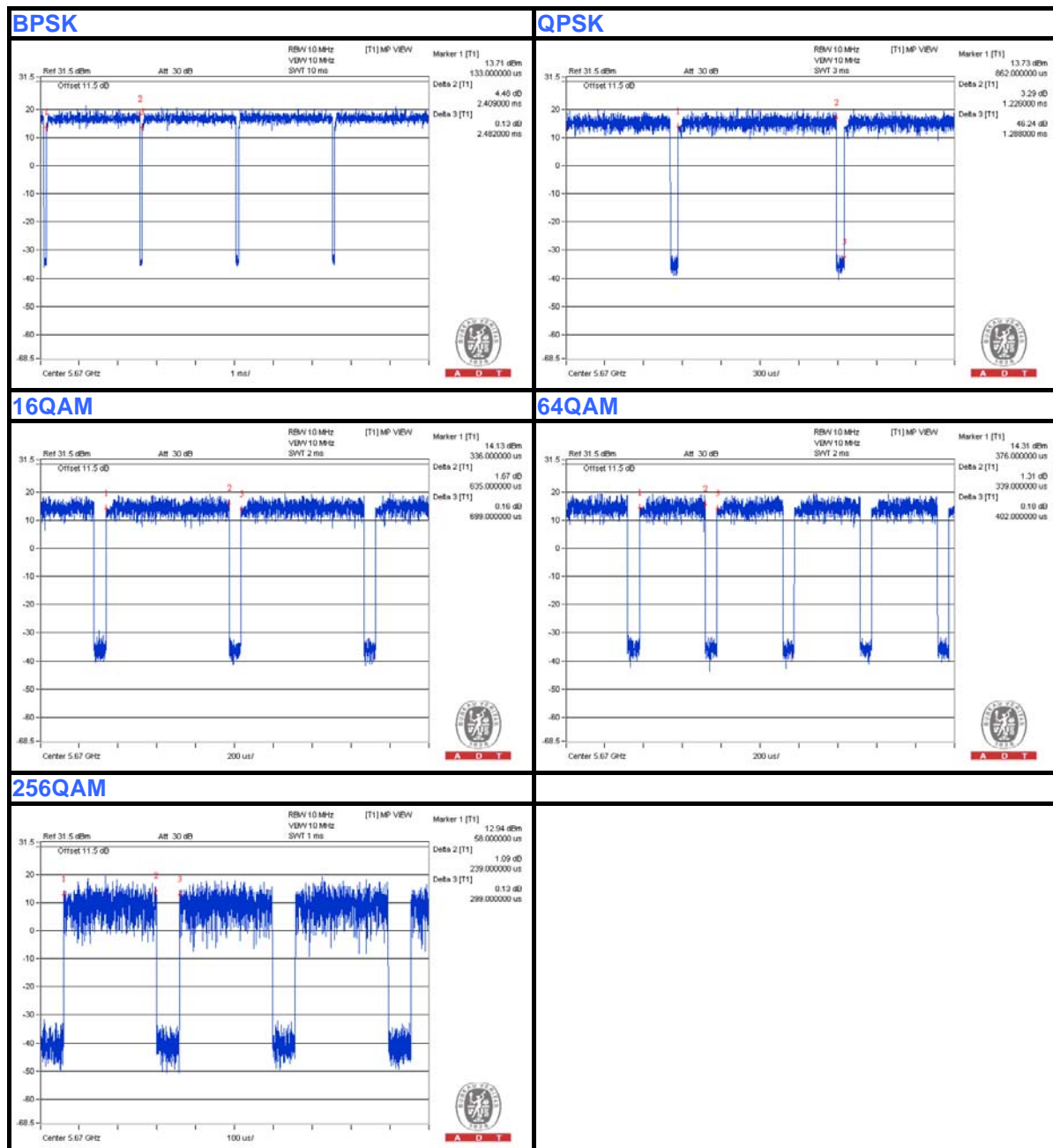

802.11ac (VHT80)

BPSK: Duty cycle = 1.135 ms/1.2 ms = 0.946, Duty factor = $10 * \log(1/0.946) = 0.24$

QPSK: Duty cycle = 0.587 ms/0.647ms = 0.907, Duty factor = $10 * \log(1/0.907) = 0.42$

16QAM: Duty cycle = 0.316 ms/0.376 ms = 0.84, Duty factor = $10 * \log(1/0.84) = 0.76$

64QAM: Duty cycle = 0.179 ms/0.239 ms = 0.749, Duty factor = $10 * \log(1/0.749) = 1.26$

256QAM: Duty cycle = 0.131 ms/0.192 ms = 0.682, Duty factor = $10 * \log(1/0.682) = 1.66$

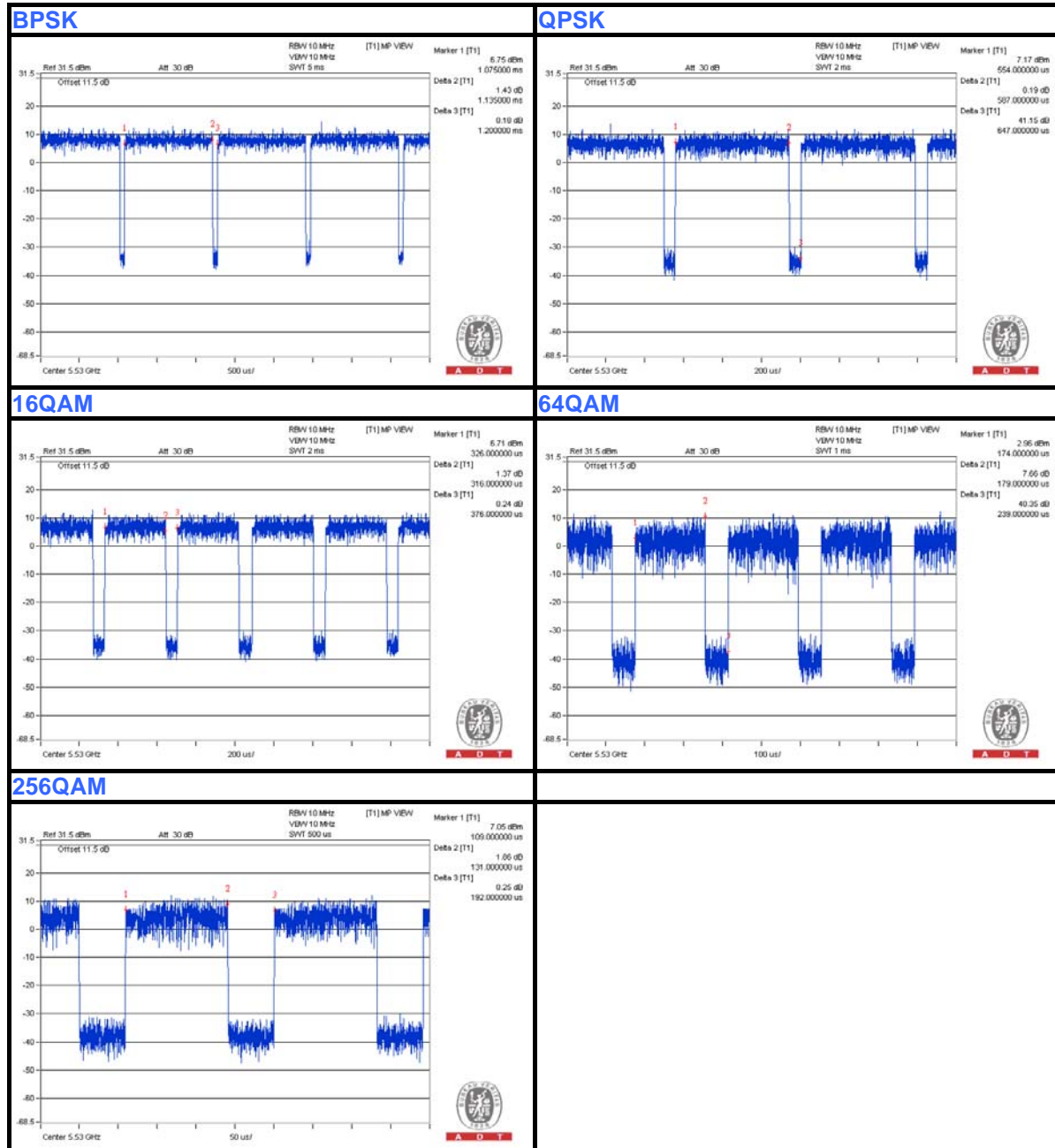



A D T

3.5 DESCRIPTION OF SUPPORT UNITS

The EUT has been tested as an independent unit together with other necessary accessories or support units. The following support units or accessories were used to form a representative test configuration during the tests.

No.	Product	Brand	Model No.	Serial No.	FCC ID	Remark
A	NOTEBOOK COMPUTER	DELL	E5430	HYV4VY1	FCC DoC	Provided by Lab
B	PoE	Power Dsine	PD-3501G/A C	NA	NA	Supplied by Client

NOTE:

- 1. All power cords of the above support units are non-shielded (1.8 m).

No.	Cable	Qty.	Length (m)	Shielded (Yes/ No)	Cores (Number)	Remark
1	UTP	1	10	No	0	Provided by Lab
2	DC	1	1.53	No	0	Supplied by Client
3	UTP	1	1	No	0	Provided by Lab

3.6 CONFIGURATION OF SYSTEM UNDER TEST

For Adapter Mode:

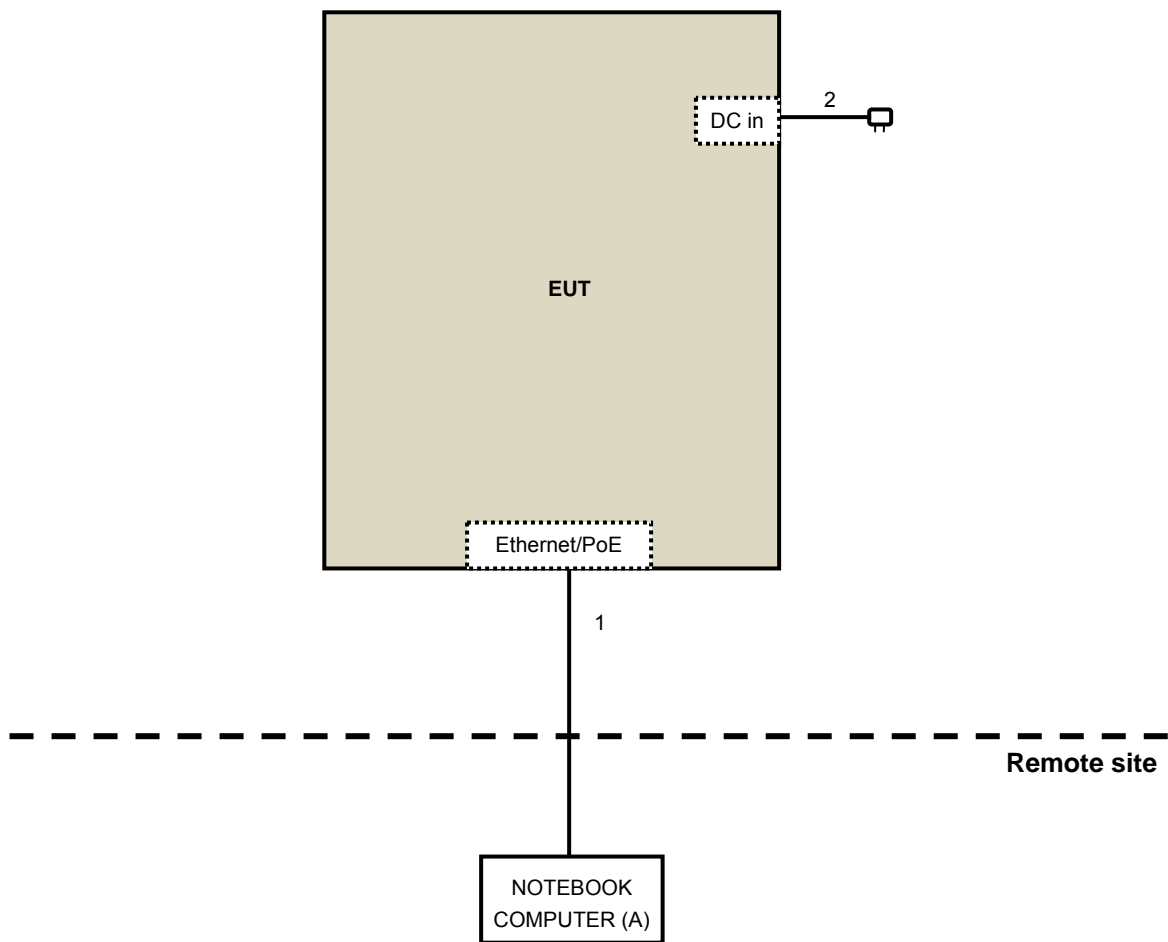



A D T

For PoE Mode:

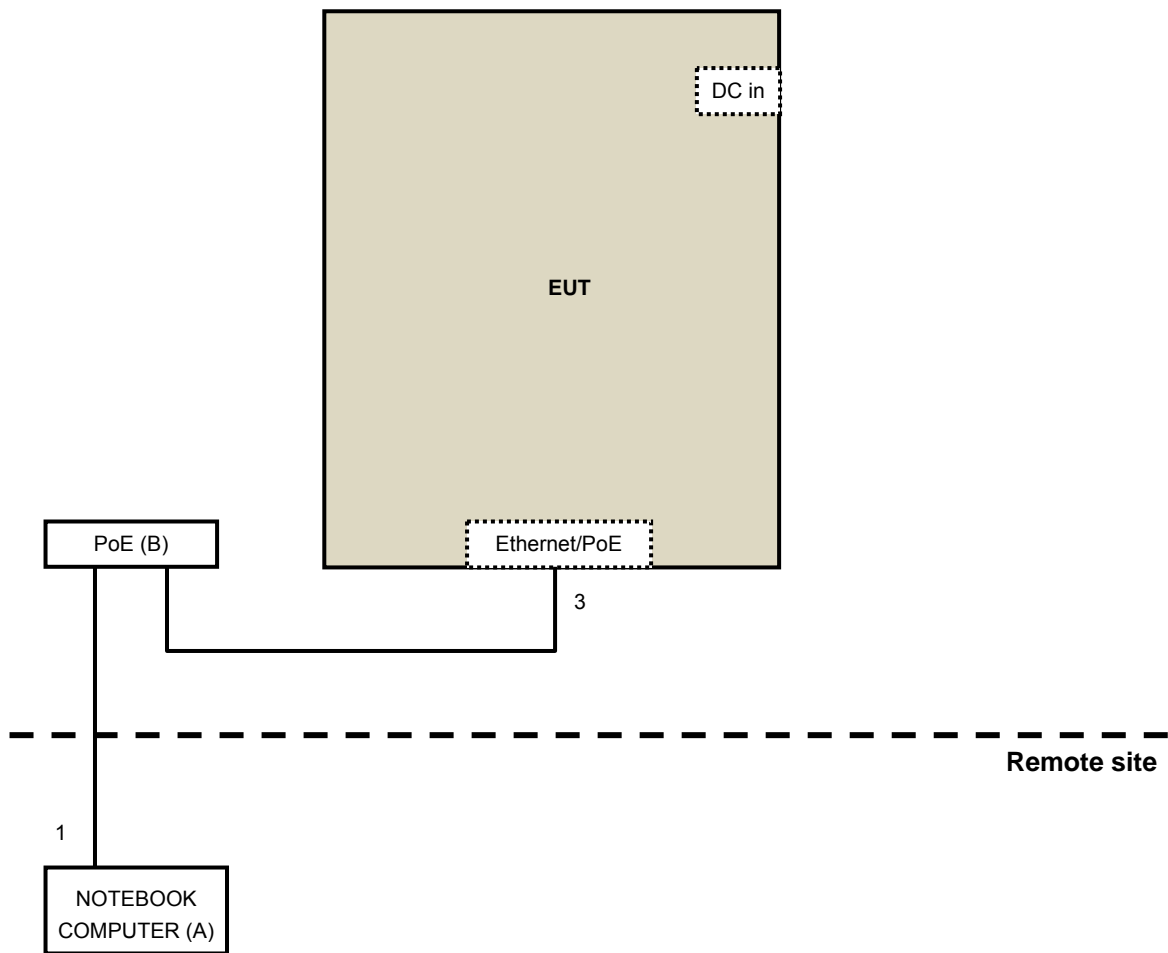



A D T

4. TEST TYPES AND RESULTS

4.1 CONDUCTED EMISSION MEASUREMENT

4.1.1 LIMITS OF CONDUCTED EMISSION MEASUREMENT

FREQUENCY OF EMISSION (MHz)	CONDUCTED LIMIT (dB μ V)	
	Quasi-peak	Average
0.15-0.5	66 to 56	56 to 46
0.5-5	56	46
5-30	60	50

- NOTE:** 1. The lower limit shall apply at the transition frequencies.
2. The limit decreases in line with the logarithm of the frequency in the range of 0.15 to 0.50 MHz.

4.1.2 TEST INSTRUMENTS

DESCRIPTION & MANUFACTURER	MODEL NO.	SERIAL NO.	CALIBRATED DATE	CALIBRATED UNTIL
Test Receiver ROHDE & SCHWARZ	ESCS 30	100375	Apr. 29, 2014	Apr. 28, 2015
Line-Impedance Stabilization Network (for EUT) SCHWARZBECK	NSLK8127	8127-522	Sep. 12, 2013	Sep. 11, 2014
Line-Impedance Stabilization Network (for Peripheral) ROHDE & SCHWARZ	ENV216	100071	Nov. 13, 2013	Nov. 12, 2014
RF Cable (JYEBAO)	5DFB	COCCAB-001	Mar. 10, 2014	Mar. 09, 2015
50 ohms Terminator	N/A	EMC-03	Sep. 24, 2013	Sep. 23, 2014
50 ohms Terminator	N/A	EMC-02	Oct. 01, 2013	Sep. 30, 2014
Software ADT	BV ADT_Cond_V7.3.7. 3	NA	NA	NA

Note:

1. The calibration interval of the above test instruments is 12 months and the calibrations are traceable to NML/ROC and NIST/USA.
2. The test was performed in Shielded Room No. C.
3. The VCCI Con C Registration No. is C-3611.
4. Tested Date: July 28, 2014

4.1.3 TEST PROCEDURES

- a. The EUT was placed 0.4 meters from the conducting wall of the shielded room with EUT being connected to the power mains through a line impedance stabilization network (LISN). Other support units were connected to the power mains through another LISN.
- b. The two LISNs provide 50 ohm/ 50uH of coupling impedance for the measuring instrument.
- c. Both lines of the power mains connected to the EUT were checked for maximum conducted interference.
- d. The frequency range from 150kHz to 30MHz was searched. Emission level under (Limit – 20dB) was not recorded.

NOTE:

1. The resolution bandwidth of test receiver is 9kHz for Quasi-peak detection (QP) & Average detection (AV).

4.1.4 DEVIATION FROM TEST STANDARD

No deviation

4.1.5 TEST SETUP

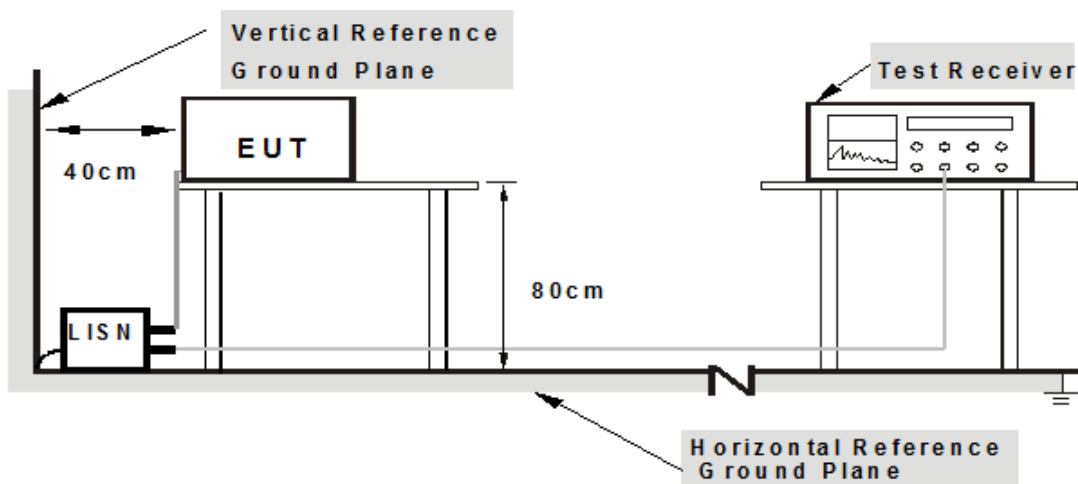

Note: 1. Support units were connected to second LISN.

For the actual test configuration, please refer to the related item – Photographs of the Test Configuration.



A D T

4.1.6 EUT OPERATING CONDITIONS

1. Turn on the power of all equipment.
2. The support unit A (Notebook Computer) runs “artgui.exe[Ver2.3]” program to enable EUT under transmission/receiving condition continuously at specific channel frequency.

4.1.7 TEST RESULTS (MODE 1)

PHASE	Line (L)	DETECTOR FUNCTION	Quasi-Peak (QP) / Average (AV)
--------------	----------	--------------------------	--------------------------------

No	Freq. [MHz]	Corr. Factor (dB)	Reading Value [dB (uV)]		Emission Level [dB (uV)]		Limit [dB (uV)]		Margin (dB)	
			Q.P.	AV.	Q.P.	AV.	Q.P.	AV.	Q.P.	AV.
1	0.15000	0.07	50.12	38.52	50.19	38.59	66.00	56.00	-15.81	-17.41
2	0.21986	0.07	39.51	30.23	39.58	30.30	62.82	52.82	-23.24	-22.52
3	0.36484	0.09	37.59	34.52	37.68	34.61	58.62	48.62	-20.94	-14.01
4	6.41283	0.34	26.97	21.54	27.31	21.88	60.00	50.00	-32.69	-28.12
5	11.22266	0.48	30.23	25.77	30.71	26.25	60.00	50.00	-29.29	-23.75
6	23.12891	0.80	33.62	31.45	34.42	32.25	60.00	50.00	-25.58	-17.75

REMARKS:

1. Q.P. and AV. are abbreviations of quasi-peak and average individually.
2. The emission levels of other frequencies were very low against the limit.
3. Margin value = Emission Level – Limit value
4. Correction Factor = Insertion loss + Cable loss
5. Emission Level = Correction Factor + Reading Value

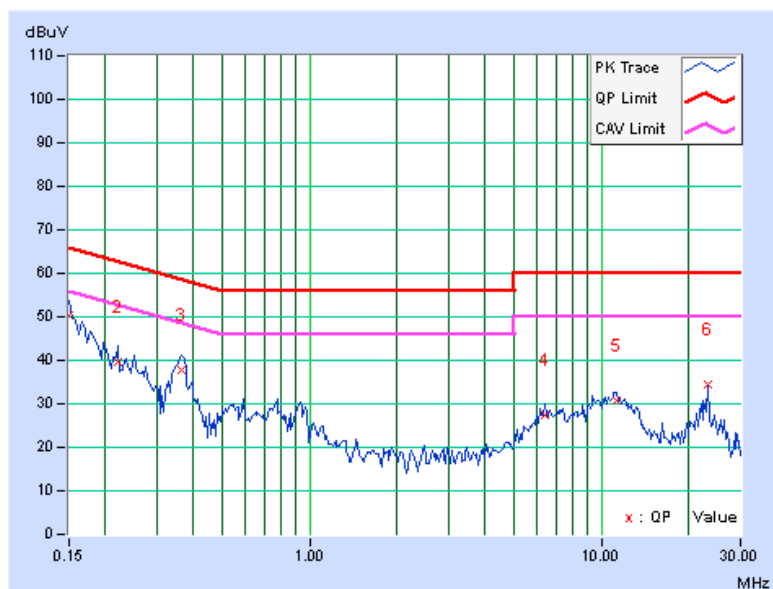

PHASE	Neutral (N)	DETECTOR FUNCTION	Quasi-Peak (QP) / Average (AV)
--------------	-------------	--------------------------	--------------------------------

No	Freq.	Corr.	Reading Value		Emission Level		Limit		Margin	
	[MHz]	Factor	[dB (uV)]		[dB (uV)]		[dB (uV)]		(dB)	
		(dB)	Q.P.	AV.	Q.P.	AV.	Q.P.	AV.	Q.P.	AV.
1	0.15000	0.08	51.36	40.29	51.44	40.37	66.00	56.00	-14.56	-15.63
2	0.36484	0.09	40.16	32.36	40.25	32.45	58.62	48.62	-18.37	-16.17
3	0.61875	0.10	26.95	23.47	27.05	23.57	56.00	46.00	-28.95	-22.43
4	6.33203	0.33	28.33	23.51	28.66	23.84	60.00	50.00	-31.34	-26.16
5	11.27734	0.48	31.63	26.54	32.11	27.02	60.00	50.00	-27.89	-22.98
6	23.12891	0.79	33.78	31.62	34.57	32.41	60.00	50.00	-25.43	-17.59

REMARKS:

1. Q.P. and AV. are abbreviations of quasi-peak and average individually.
2. The emission levels of other frequencies were very low against the limit.
3. Margin value = Emission Level – Limit value
4. Correction Factor = Insertion loss + Cable loss
5. Emission Level = Correction Factor + Reading Value

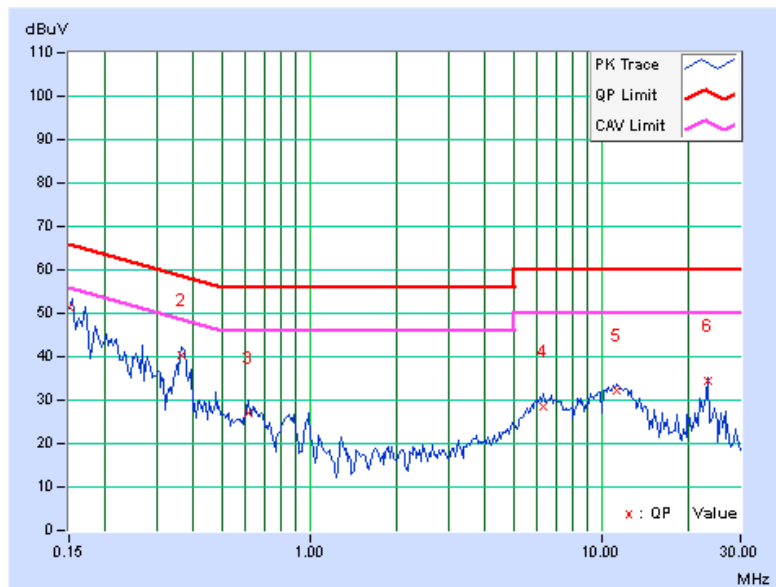

4.1.8 TEST RESULTS (MODE 2)

PHASE	Line (L)	DETECTOR FUNCTION	Quasi-Peak (QP) / Average (AV)
--------------	----------	--------------------------	--------------------------------

No	Freq. [MHz]	Corr. Factor (dB)	Reading Value [dB (uV)]		Emission Level [dB (uV)]		Limit [dB (uV)]		Margin (dB)	
			Q.P.	AV.	Q.P.	AV.	Q.P.	AV.	Q.P.	AV.
1	0.15000	0.07	45.23	37.42	45.30	37.49	66.00	56.00	-20.70	-18.51
2	0.18125	0.07	40.16	26.99	40.23	27.06	64.43	54.43	-24.20	-27.37
3	0.51328	0.10	35.25	31.78	35.35	31.88	56.00	46.00	-20.65	-14.12
4	3.64453	0.24	23.52	18.63	23.76	18.87	56.00	46.00	-32.24	-27.13
5	23.21875	0.80	43.78	36.12	44.58	36.92	60.00	50.00	-15.42	-13.08
6	29.23438	0.98	42.53	36.45	43.51	37.43	60.00	50.00	-16.49	-12.57

REMARKS:

1. Q.P. and AV. are abbreviations of quasi-peak and average individually.
2. The emission levels of other frequencies were very low against the limit.
3. Margin value = Emission Level – Limit value
4. Correction Factor = Insertion loss + Cable loss
5. Emission Level = Correction Factor + Reading Value

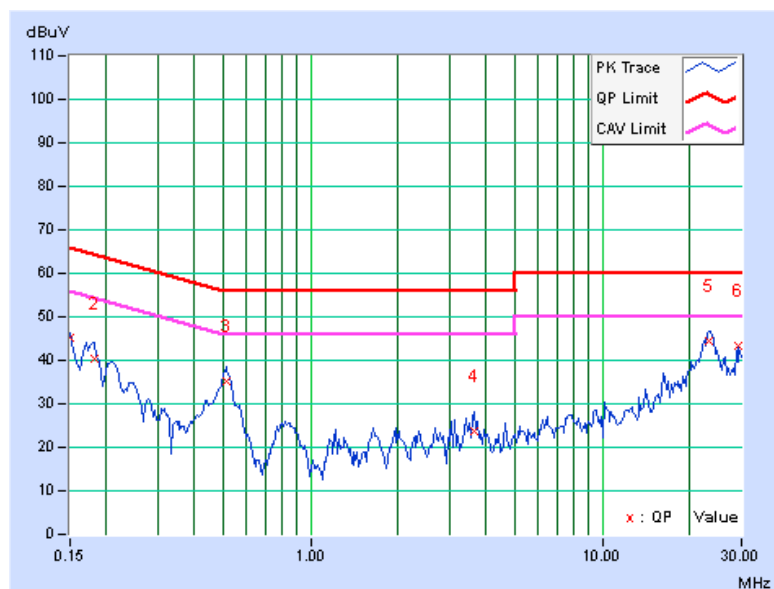

PHASE	Neutral (N)	DETECTOR FUNCTION	Quasi-Peak (QP) / Average (AV)
--------------	-------------	--------------------------	--------------------------------

No	Freq.	Corr.	Reading Value		Emission Level		Limit		Margin	
	[MHz]	Factor	[dB (uV)]		[dB (uV)]		[dB (uV)]		(dB)	
		(dB)	Q.P.	AV.	Q.P.	AV.	Q.P.	AV.	Q.P.	AV.
1	0.15000	0.08	47.32	37.55	47.40	37.63	66.00	56.00	-18.60	-18.37
2	0.18906	0.07	41.39	30.16	41.46	30.23	64.08	54.08	-22.62	-23.85
3	0.52109	0.10	37.62	33.51	37.72	33.61	56.00	46.00	-18.28	-12.39
4	3.70703	0.25	28.59	22.15	28.83	22.40	56.00	46.00	-27.17	-23.60
5	23.27734	0.79	44.32	36.25	45.11	37.04	60.00	50.00	-14.89	-12.96
6	28.68359	0.95	40.78	39.55	41.73	40.50	60.00	50.00	-18.27	-9.50

REMARKS:

1. Q.P. and AV. are abbreviations of quasi-peak and average individually.
2. The emission levels of other frequencies were very low against the limit.
3. Margin value = Emission Level – Limit value
4. Correction Factor = Insertion loss + Cable loss
5. Emission Level = Correction Factor + Reading Value

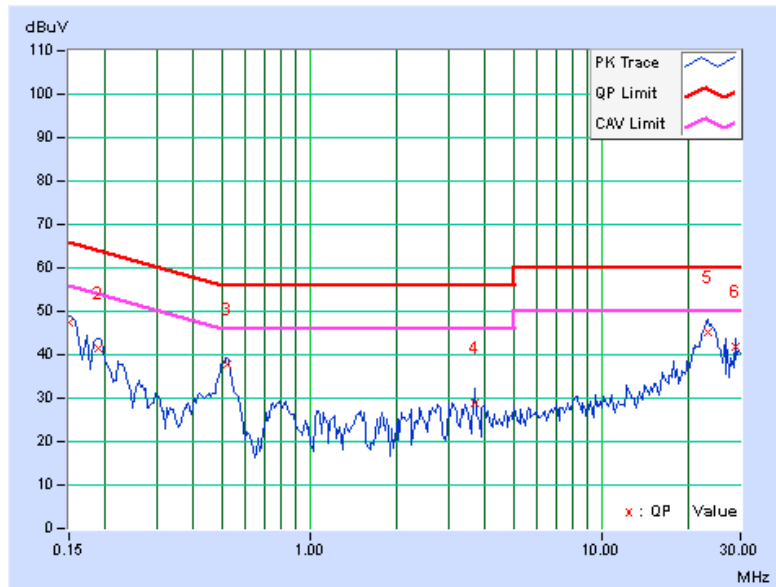



4.2 RADIATED EMISSION AND BANDEDGE MEASUREMENT

4.2.1 LIMITS OF RADIATED EMISSION AND BANDEDGE MEASUREMENT

Radiated emissions which fall in the restricted bands must comply with the radiated emission limits specified as below table:

Frequencies (MHz)	Field strength (microvolts/meter)	Measurement distance (meters)
0.009-0.490	2400/F(kHz)	300
0.490-1.705	24000/F(kHz)	30
1.705-30.0	30	30
30-88	100	3
88-216	150	3
216-960	200	3
Above 960	500	3

NOTE:

1. The lower limit shall apply at the transition frequencies.
2. Emission level (dBuV/m) = 20 log Emission level (uV/m).
3. For frequencies above 1000MHz, the field strength limits are based on average detector, however, the peak field strength of any emission shall not exceed the maximum permitted average limits, specified above by more than 20dB under any condition of modulation.

4.2.2 LIMITS OF UNWANTED EMISSION OUT OF THE RESTRICTED BANDS

LIMIT	
FIELD STRENGTH AT 3m (dBµV/m)	
PK	AV
74	54
EIRP LIMIT (dBm)	EQUIVALENT FIELD STRENGTH AT 3m (dBµV/m)
PK	PK
-27	68.2

NOTE:

1. The following formula is used to convert the equipment isotropic radiated power (eirp) to field strength:

$$E = \frac{1000000\sqrt{30P}}{3} \mu\text{V/m, where P is the eirp (Watts).$$



A D T

4.2.3 TEST INSTRUMENTS

For Below 1GHz:

DESCRIPTION & MANUFACTURER	MODEL NO.	SERIAL NO.	CALIBRATED DATE	CALIBRATED UNTIL
MXE EMI Receiver Agilent	N9038A	MY51210105	Jan. 21,2014	Jan. 20,2015
Pre-Amplifier Mini-Circuits	ZFL-1000VH2 B	AMP-ZFL-03	Nov. 13, 2013	Nov. 12, 2014
Trilog Broadband Antenna SCHWARZBECK	VULB 9168	9168-360	Feb. 26, 2014	Feb. 25, 2015
RF Cable	NA	CHGCAB_001	Oct. 05, 2013	Oct. 04, 2014
Spectrum Analyzer R&S	FSV40	100964	July 05, 2014	July 04, 2015
Horn_Antenna AISI	AIH.8018	0000320091110	Nov. 18, 2013	Nov. 17, 2014
Pre-Amplifier Agilent	8449B	3008A02578	June 24, 2014	June 23, 2015
RF Cable	NA	RF104-201 RF104-203 RF104-204	Dec. 12, 2013	Dec. 11, 2014
Spectrum Analyzer Agilent	E4446A	MY48250253	Aug. 28, 2013	Aug. 27, 2014
Pre-Amplifier SPACEK LABS	SLKKa-48-6	9K16	Nov. 13, 2013	Nov. 12, 2014
Horn_Antenna SCHWARZBECK	BBHA 9170	9170-424	Oct. 08, 2013	Oct. 07, 2014
Software	ADT_Radiated _V8.7.07	NA	NA	NA
Antenna Tower & Turn Table CT	NA	NA	NA	NA

Note:

1. The calibration interval of the above test instruments is 12 months and the calibrations are traceable to NML/ROC and NIST/USA.
2. The horn antenna, preamplifier (model: 8449B) are used only for the measurement of emission frequency above 1GHz if tested.
- 3 The test was performed in 966 Chamber No. G.
4. The FCC Site Registration No. is 966073.
- 5 The VCCI Site Registration No. is G-137.
- 6 The CANADA Site Registration No. is IC 7450H-2.
- 7 Tested Date: July 28, 2014



A D T

For Above 1GHz:

DESCRIPTION & MANUFACTURER	MODEL NO.	SERIAL NO.	CALIBRATED DATE	CALIBRATED UNTIL
MXE EMI Receiver Agilent	N9038A	MY50010156	Jan. 15, 2014	Jan. 14, 2015
Pre-Amplifier Mini-Circuits	ZFL-1000VH2 B	AMP-ZFL-04	Nov. 13, 2013	Nov. 12, 2014
Trilog Broadband Antenna SCHWARZBECK	VULB 9168	9168-361	Feb. 27, 2014	Feb. 26, 2015
RF Cable	NA	CHHCAB_001	Oct. 06, 2013	Oct. 05, 2014
Spectrum Analyzer R&S	FSV40	100964	July 05, 2014	July 04, 2015
Horn_Antenna AISI	AIH.8018	0000220091110	Dec. 06, 2013	Dec. 05, 2014
Pre-Amplifier Agilent	8449B	3008A01923	Oct. 29, 2013	Oct. 28, 2014
RF Cable	NA	RF104-205 RF104-207 RF104-202	Dec. 12, 2013	Dec. 11, 2014
Spectrum Analyzer Agilent	E4446A	MY48250253	Aug. 28, 2013	Aug. 27, 2014
Pre-Amplifier SPACEK LABS	SLKKa-48-6	9K16	Nov. 13, 2013	Nov. 12, 2014
Horn_Antenna SCHWARZBECK	BBHA 9170	9170-424	Oct. 08, 2013	Oct. 07, 2014
Software	ADT_Radiated _V8.7.07	NA	NA	NA
Antenna Tower & Turn Table CT	NA	NA	NA	NA

Note:

1. The calibration interval of the above test instruments is 12 months and the calibrations are traceable to NML/ROC and NIST/USA.
2. The horn antenna, preamplifier (model: 8449B) are used only for the measurement of emission frequency above 1GHz if tested.
3. The test was performed in 966 Chamber No. H.
4. The FCC Site Registration No. is 797305.
5. The CANADA Site Registration No. is IC 7450H-3.
6. Tested Date: Aug. 08, 2014

4.2.4 TEST PROCEDURES

- a. The EUT was placed on the top of a rotating table 0.8 meters above the ground at 3 meter chamber room for test. The table was rotated 360 degrees to determine the position of the highest radiation.
- b. The EUT was set 3 meters away from the interference-receiving antenna, which was mounted on the top of a variable-height antenna tower.
- c. The height of antenna is varied from one meter to four meters above the ground to determine the maximum value of the field strength. Both horizontal and vertical polarizations of the antenna are set to make the measurement.
- d. For each suspected emission, the EUT was arranged to its worst case and then the antenna was tuned to heights from 1 meter to 4 meters and the rotatable table was turned from 0 degrees to 360 degrees to find the maximum reading.
- e. The test-receiver system was set to quasi-peak detect function and specified bandwidth with maximum hold mode when the test frequency is below 1 GHz.
- f. The test-receiver system was set to peak and average detect function and specified bandwidth with maximum hold mode when the test frequency is above 1 GHz. If the peak reading value also meets average limit, measurement with the average detector is unnecessary.

Note:

1. The resolution bandwidth and video bandwidth of test receiver/spectrum analyzer is 120kHz for Quasi-peak detection (QP) at frequency below 1GHz.
2. The resolution bandwidth of test receiver/spectrum analyzer is 1 MHz and the video bandwidth is 3 MHz for Peak detection (PK) at frequency above 1GHz.
3. The resolution bandwidth of test receiver/spectrum analyzer is 1MHz and the video bandwidth is 3MHz for RMS Average (Duty cycle < 98%) for Average detection (AV) at frequency above 1GHz, then the measurement results was added to a correction factor ($10 \log(1/\text{duty cycle})$).
4. The resolution bandwidth of test receiver/spectrum analyzer is 1MHz and the video bandwidth is 10Hz (Duty cycle $\geq 98\%$) for Average detection (AV) at frequency above 1GHz.
5. All modes of operation were investigated and the worst-case emissions are reported.

4.2.5 DEVIATION FROM TEST STANDARD

No deviation

4.2.6 TEST SETUP

<Frequency Range below 1GHz>

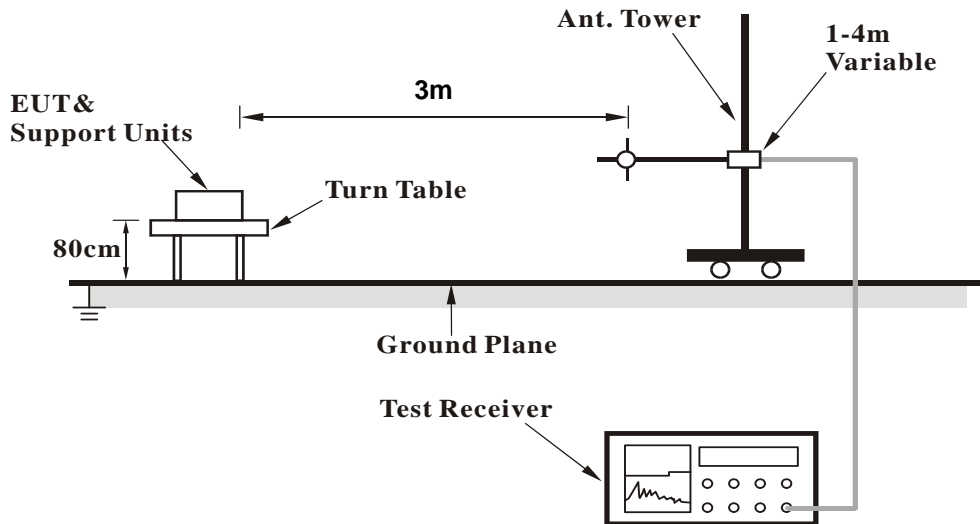

<Frequency Range above 1GHz>

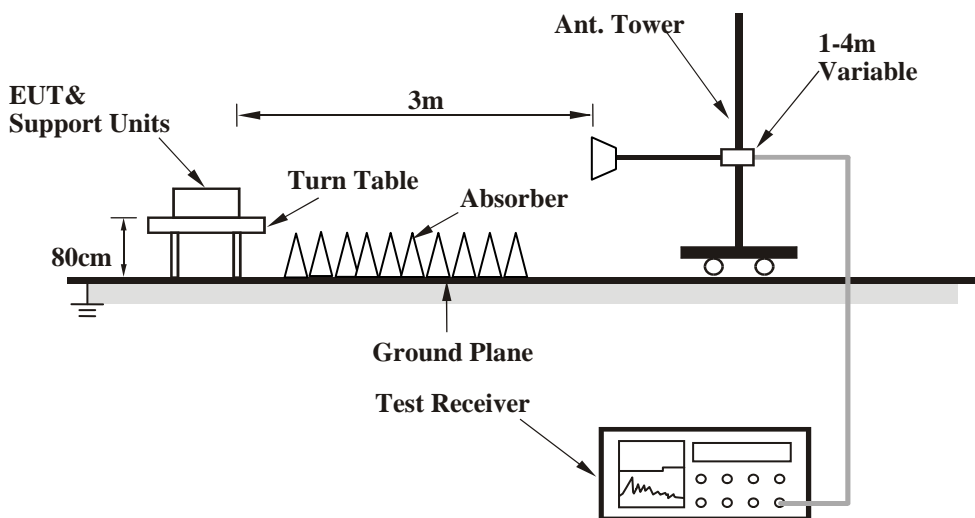

For the actual test configuration, please refer to the related item – Photographs of the Test Configuration.

4.2.7 EUT OPERATING CONDITION

Same as 4.1.6



A D T

4.2.8 TEST RESULTS

BELOW 1GHz WORST-CASE DATA

802.11ac (VHT40)

CHANNEL	TX Channel 110	DETECTOR FUNCTION	Quasi-Peak (QP)
FREQUENCY RANGE	Below 1GHz		

ANTENNA POLARITY & TEST DISTANCE: HORIZONTAL AT 3 M

NO.	FREQ. (MHz)	EMISSION LEVEL (dBuV/m)	LIMIT (dBuV/m)	MARGIN (dB)	ANTENNA HEIGHT (m)	TABLE ANGLE (Degree)	RAW VALUE (dBuV)	CORRECTION FACTOR (dB/m)
1	60.65	30.8 QP	40.0	-9.2	1.50 H	218	45.00	-14.21
2	258.34	38.0 QP	46.0	-8.0	2.00 H	145	52.02	-13.99
3	340.01	38.8 QP	46.0	-7.3	1.50 H	274	50.05	-11.30
4	401.90	36.1 QP	46.0	-9.9	2.00 H	118	45.75	-9.69
5	875.02	37.8 QP	46.0	-8.2	1.00 H	205	38.25	-0.45
6	1000.00	44.4 QP	54.0	-9.6	1.00 H	154	42.90	1.46

ANTENNA POLARITY & TEST DISTANCE: VERTICAL AT 3 M

NO.	FREQ. (MHz)	EMISSION LEVEL (dBuV/m)	LIMIT (dBuV/m)	MARGIN (dB)	ANTENNA HEIGHT (m)	TABLE ANGLE (Degree)	RAW VALUE (dBuV)	CORRECTION FACTOR (dB/m)
1	47.36	31.4 QP	40.0	-8.6	1.51 V	203	44.90	-13.52
2	118.03	34.4 QP	43.5	-9.1	1.50 V	143	49.73	-15.31
3	141.21	35.1 QP	43.5	-8.4	1.50 V	188	48.67	-13.61
4	409.61	33.5 QP	46.0	-12.5	1.50 V	211	43.01	-9.52
5	625.00	33.8 QP	46.0	-12.2	1.00 V	115	38.17	-4.41
6	999.95	40.1 QP	54.0	-13.9	1.00 V	241	38.60	1.46

REMARKS:

1. Emission Level(dBuV/m) = Raw Value(dBuV) + Correction Factor(dB/m)
2. Correction Factor(dB/m) = Antenna Factor(dB/m) + Cable Factor(dB) – Pre-Amplifier Factor(dB)
3. The other emission levels were very low against the limit.
4. Margin value = Emission Level – Limit value



A D T

ABOVE 1GHz DATA

802.11a

CHANNEL	TX Channel 52	DETECTOR FUNCTION	Peak (PK)
FREQUENCY RANGE	1GHz ~ 40GHz		Average (AV)

ANTENNA POLARITY & TEST DISTANCE: HORIZONTAL AT 3 M

NO.	FREQ. (MHz)	EMISSION LEVEL (dBuV/m)	LIMIT (dBuV/m)	MARGIN (dB)	ANTENNA HEIGHT (m)	TABLE ANGLE (Degree)	RAW VALUE (dBuV)	CORRECTION FACTOR (dB/m)
1	5150.00	51.7 PK	74.0	-22.3	1.02 H	151	47.86	3.84
2	5150.00	39.6 AV	54.0	-14.4	1.02 H	151	35.76	3.84
3	*5260.00	111.6 PK			1.02 H	151	107.65	3.95
4	*5260.00	103.4 AV			1.02 H	151	99.45	3.95
5	5350.00	53.2 PK	74.0	-20.8	1.02 H	151	49.13	4.07
6	5350.00	41.3 AV	54.0	-12.7	1.02 H	151	37.23	4.07
7	#10520.00	62.7 PK	74.0	-11.3	1.21 H	54	52.92	9.78
8	#10520.00	49.6 AV	54.0	-4.4	1.21 H	54	39.82	9.78
9	15780.00	64.7 PK	74.0	-9.3	1.03 H	303	50.77	13.93
10	15780.00	52.6 AV	54.0	-1.4	1.03 H	303	38.67	13.93

ANTENNA POLARITY & TEST DISTANCE: VERTICAL AT 3 M

NO.	FREQ. (MHz)	EMISSION LEVEL (dBuV/m)	LIMIT (dBuV/m)	MARGIN (dB)	ANTENNA HEIGHT (m)	TABLE ANGLE (Degree)	RAW VALUE (dBuV)	CORRECTION FACTOR (dB/m)
1	5150.00	56.1 PK	74.0	-17.9	1.39 V	132	52.26	3.84
2	5150.00	44.4 AV	54.0	-9.6	1.39 V	132	40.56	3.84
3	*5260.00	123.4 PK			1.39 V	132	119.45	3.95
4	*5260.00	115.4 AV			1.39 V	132	111.45	3.95
5	5350.00	56.7 PK	74.0	-17.3	1.39 V	132	52.62	4.07
6	5350.00	45.0 AV	54.0	-9.0	1.39 V	132	40.93	4.07
7	#10520.00	63.1 PK	74.0	-10.9	1.00 V	7	53.32	9.78
8	#10520.00	49.6 AV	54.0	-4.4	1.00 V	7	39.82	9.78
9	15780.00	66.4 PK	74.0	-7.6	1.07 V	7	52.47	13.93
10	15780.00	53.5 AV	54.0	-0.5	1.07 V	7	39.57	13.93

REMARKS:

1. Emission Level(dBuV/m) = Raw Value(dBuV) + Correction Factor(dB/m)
2. Correction Factor(dB/m) = Antenna Factor(dB/m) + Cable Factor(dB) – Pre-Amplifier Factor(dB)
3. The other emission levels were very low against the limit.
4. Margin value = Emission Level – Limit value
5. " * ": Fundamental frequency.
6. " # ": The radiated frequency is out of the restricted band.



A D T

CHANNEL	TX Channel 60	DETECTOR FUNCTION	Peak (PK)
FREQUENCY RANGE	1GHz ~ 40GHz		Average (AV)

ANTENNA POLARITY & TEST DISTANCE: HORIZONTAL AT 3 M

NO.	FREQ. (MHz)	EMISSION LEVEL (dBuV/m)	LIMIT (dBuV/m)	MARGIN (dB)	ANTENNA HEIGHT (m)	TABLE ANGLE (Degree)	RAW VALUE (dBuV)	CORRECTION FACTOR (dB/m)
1	*5300.00	104.9 PK			1.02 H	150	100.96	3.94
2	*5300.00	95.5 AV			1.02 H	150	91.56	3.94
3	10600.00	60.4 PK	74.0	-13.6	1.24 H	63	50.33	10.07
4	10600.00	47.6 AV	54.0	-6.4	1.24 H	63	37.53	10.07
5	15900.00	62.1 PK	74.0	-11.9	1.06 H	307	47.88	14.22
6	15900.00	50.3 AV	54.0	-3.7	1.06 H	307	36.08	14.22

ANTENNA POLARITY & TEST DISTANCE: VERTICAL AT 3 M

NO.	FREQ. (MHz)	EMISSION LEVEL (dBuV/m)	LIMIT (dBuV/m)	MARGIN (dB)	ANTENNA HEIGHT (m)	TABLE ANGLE (Degree)	RAW VALUE (dBuV)	CORRECTION FACTOR (dB/m)
1	*5300.00	116.7 PK			1.45 V	106	112.76	3.94
2	*5300.00	106.9 AV			1.45 V	106	102.96	3.94
3	10600.00	61.4 PK	74.0	-12.6	1.02 V	12	51.33	10.07
4	10600.00	46.5 AV	54.0	-7.5	1.02 V	12	36.43	10.07
5	15900.00	64.3 PK	74.0	-9.7	1.08 V	10	50.08	14.22
6	15900.00	51.4 AV	54.0	-2.6	1.08 V	10	37.18	14.22

REMARKS:

1. Emission Level(dBuV/m) = Raw Value(dBuV) + Correction Factor(dB/m)
2. Correction Factor(dB/m) = Antenna Factor(dB/m) + Cable Factor(dB) – Pre-Amplifier Factor(dB)
3. The other emission levels were very low against the limit.
4. Margin value = Emission Level – Limit value
5. " * ": Fundamental frequency.



A D T

CHANNEL	TX Channel 64	DETECTOR FUNCTION	Peak (PK)
FREQUENCY RANGE	1GHz ~ 40GHz		Average (AV)

ANTENNA POLARITY & TEST DISTANCE: HORIZONTAL AT 3 M

NO.	FREQ. (MHz)	EMISSION LEVEL (dBuV/m)	LIMIT (dBuV/m)	MARGIN (dB)	ANTENNA HEIGHT (m)	TABLE ANGLE (Degree)	RAW VALUE (dBuV)	CORRECTION FACTOR (dB/m)
1	*5320.00	104.7 PK			1.03 H	165	100.71	3.99
2	*5320.00	95.5 AV			1.03 H	165	91.51	3.99
3	5350.00	69.0 PK	74.0	-5.0	1.03 H	165	64.93	4.07
4	5350.00	50.0 AV	54.0	-4.0	1.03 H	165	45.93	4.07
5	10640.00	60.6 PK	74.0	-13.4	1.16 H	38	50.59	10.01
6	10640.00	47.6 AV	54.0	-6.4	1.16 H	38	37.59	10.01
7	15960.00	61.2 PK	74.0	-12.8	1.02 H	307	47.05	14.15
8	15960.00	49.4 AV	54.0	-4.6	1.02 H	307	35.25	14.15

ANTENNA POLARITY & TEST DISTANCE: VERTICAL AT 3 M

NO.	FREQ. (MHz)	EMISSION LEVEL (dBuV/m)	LIMIT (dBuV/m)	MARGIN (dB)	ANTENNA HEIGHT (m)	TABLE ANGLE (Degree)	RAW VALUE (dBuV)	CORRECTION FACTOR (dB/m)
1	*5320.00	116.8 PK			1.37 V	133	112.81	3.99
2	*5320.00	106.2 AV			1.37 V	133	102.21	3.99
3	5350.00	69.5 PK	74.0	-4.5	1.37 V	133	65.43	4.07
4	5350.00	52.6 AV	54.0	-1.4	1.37 V	133	48.53	4.07
5	10640.00	61.5 PK	74.0	-12.5	1.03 V	2	51.49	10.01
6	10640.00	46.7 AV	54.0	-7.3	1.03 V	2	36.69	10.01
7	15960.00	64.6 PK	74.0	-9.4	1.10 V	10	50.45	14.15
8	15960.00	51.6 AV	54.0	-2.4	1.10 V	10	37.45	14.15

REMARKS:

1. Emission Level(dBuV/m) = Raw Value(dBuV) + Correction Factor(dB/m)
2. Correction Factor(dB/m) = Antenna Factor(dB/m) + Cable Factor(dB) – Pre-Amplifier Factor(dB)
3. The other emission levels were very low against the limit.
4. Margin value = Emission Level – Limit value
5. " * ": Fundamental frequency.



A D T

CHANNEL	TX Channel 100	DETECTOR FUNCTION	Peak (PK)
FREQUENCY RANGE	1GHz ~ 40GHz		Average (AV)

ANTENNA POLARITY & TEST DISTANCE: HORIZONTAL AT 3 M

NO.	FREQ. (MHz)	EMISSION LEVEL (dBuV/m)	LIMIT (dBuV/m)	MARGIN (dB)	ANTENNA HEIGHT (m)	TABLE ANGLE (Degree)	RAW VALUE (dBuV)	CORRECTION FACTOR (dB/m)
1	#5470.00	69.3 PK	74.0	-4.7	1.07 H	159	65.13	4.17
2	#5470.00	50.4 AV	54.0	-3.6	1.07 H	159	46.23	4.17
3	*5500.00	104.7 PK			1.07 H	159	100.54	4.16
4	*5500.00	95.3 AV			1.07 H	159	91.14	4.16
5	11000.00	60.7 PK	74.0	-13.3	1.18 H	47	50.47	10.23
6	11000.00	47.8 AV	54.0	-6.2	1.18 H	47	37.57	10.23
7	#16500.00	61.8 PK	74.0	-12.2	1.06 H	314	45.60	16.20
8	#16500.00	49.8 AV	54.0	-4.2	1.06 H	314	33.60	16.20

ANTENNA POLARITY & TEST DISTANCE: VERTICAL AT 3 M

NO.	FREQ. (MHz)	EMISSION LEVEL (dBuV/m)	LIMIT (dBuV/m)	MARGIN (dB)	ANTENNA HEIGHT (m)	TABLE ANGLE (Degree)	RAW VALUE (dBuV)	CORRECTION FACTOR (dB/m)
1	#5470.00	72.4 PK	74.0	-1.6	1.41 V	118	68.23	4.17
2	#5470.00	52.7 AV	54.0	-1.3	1.41 V	118	48.53	4.17
3	*5500.00	116.3 PK			1.41 V	118	112.14	4.16
4	*5500.00	106.4 AV			1.41 V	118	102.24	4.16
5	11000.00	61.5 PK	74.0	-12.5	1.00 V	21	51.27	10.23
6	11000.00	46.7 AV	54.0	-7.3	1.00 V	21	36.47	10.23
7	#16500.00	64.5 PK	74.0	-9.5	1.03 V	23	48.30	16.20
8	#16500.00	51.7 AV	54.0	-2.3	1.03 V	23	35.50	16.20

REMARKS:

1. Emission Level(dBuV/m) = Raw Value(dBuV) + Correction Factor(dB/m)
2. Correction Factor(dB/m) = Antenna Factor(dB/m) + Cable Factor(dB) – Pre-Amplifier Factor(dB)
3. The other emission levels were very low against the limit.
4. Margin value = Emission Level – Limit value
5. " * ": Fundamental frequency.
6. " # ": The radiated frequency is out of the restricted band.



A D T

CHANNEL	TX Channel 116	DETECTOR FUNCTION	Peak (PK)
FREQUENCY RANGE	1GHz ~ 40GHz		Average (AV)

ANTENNA POLARITY & TEST DISTANCE: HORIZONTAL AT 3 M

NO.	FREQ. (MHz)	EMISSION LEVEL (dBuV/m)	LIMIT (dBuV/m)	MARGIN (dB)	ANTENNA HEIGHT (m)	TABLE ANGLE (Degree)	RAW VALUE (dBuV)	CORRECTION FACTOR (dB/m)
1	*5580.00	105.0 PK			1.02 H	173	100.57	4.43
2	*5580.00	95.4 AV			1.02 H	173	90.97	4.43
3	11160.00	60.4 PK	74.0	-13.6	1.23 H	63	50.29	10.11
4	11160.00	47.5 AV	54.0	-6.5	1.23 H	63	37.39	10.11
5	#16740.00	62.1 PK	74.0	-11.9	1.04 H	304	45.01	17.09
6	#16740.00	50.3 AV	54.0	-3.7	1.04 H	304	33.21	17.09

ANTENNA POLARITY & TEST DISTANCE: VERTICAL AT 3 M

NO.	FREQ. (MHz)	EMISSION LEVEL (dBuV/m)	LIMIT (dBuV/m)	MARGIN (dB)	ANTENNA HEIGHT (m)	TABLE ANGLE (Degree)	RAW VALUE (dBuV)	CORRECTION FACTOR (dB/m)
1	*5580.00	115.8 PK			1.38 V	111	111.37	4.43
2	*5580.00	106.0 AV			1.38 V	111	101.57	4.43
3	11160.00	61.9 PK	74.0	-12.1	1.02 V	35	51.79	10.11
4	11160.00	46.9 AV	54.0	-7.1	1.02 V	35	36.79	10.11
5	#16740.00	64.5 PK	74.0	-9.5	1.04 V	11	47.41	17.09
6	#16740.00	51.6 AV	54.0	-2.4	1.04 V	11	34.51	17.09

REMARKS:

1. Emission Level(dBuV/m) = Raw Value(dBuV) + Correction Factor(dB/m)
2. Correction Factor(dB/m) = Antenna Factor(dB/m) + Cable Factor(dB) – Pre-Amplifier Factor(dB)
3. The other emission levels were very low against the limit.
4. Margin value = Emission Level – Limit value
5. " * ": Fundamental frequency.
6. " # ": The radiated frequency is out of the restricted band.



A D T

CHANNEL	TX Channel 132	DETECTOR FUNCTION	Peak (PK)
FREQUENCY RANGE	1GHz ~ 40GHz		Average (AV)

ANTENNA POLARITY & TEST DISTANCE: HORIZONTAL AT 3 M

NO.	FREQ. (MHz)	EMISSION LEVEL (dBuV/m)	LIMIT (dBuV/m)	MARGIN (dB)	ANTENNA HEIGHT (m)	TABLE ANGLE (Degree)	RAW VALUE (dBuV)	CORRECTION FACTOR (dB/m)
1	*5660.00	112.0 PK			1.00 H	142	107.50	4.50
2	*5660.00	103.8 AV			1.00 H	142	99.30	4.50
3	11320.00	62.6 PK	74.0	-11.4	1.26 H	59	52.45	10.15
4	11320.00	49.7 AV	54.0	-4.3	1.26 H	59	39.55	10.15
5	#16980.00	64.7 PK	74.0	-9.3	1.00 H	302	47.11	17.59
6	#16980.00	52.9 AV	54.0	-1.1	1.00 H	302	35.31	17.59

ANTENNA POLARITY & TEST DISTANCE: VERTICAL AT 3 M

NO.	FREQ. (MHz)	EMISSION LEVEL (dBuV/m)	LIMIT (dBuV/m)	MARGIN (dB)	ANTENNA HEIGHT (m)	TABLE ANGLE (Degree)	RAW VALUE (dBuV)	CORRECTION FACTOR (dB/m)
1	*5660.00	123.5 PK			1.37 V	135	119.00	4.50
2	*5660.00	115.2 AV			1.37 V	135	110.70	4.50
3	11320.00	62.8 PK	74.0	-11.2	1.04 V	11	52.65	10.15
4	11320.00	49.5 AV	54.0	-4.5	1.04 V	11	39.35	10.15
5	#16980.00	67.9 PK	74.0	-6.1	1.26 V	360	50.31	17.59
6	#16980.00	53.5 AV	54.0	-0.5	1.26 V	360	35.91	17.59

REMARKS:

1. Emission Level(dBuV/m) = Raw Value(dBuV) + Correction Factor(dB/m)
2. Correction Factor(dB/m) = Antenna Factor(dB/m) + Cable Factor(dB) – Pre-Amplifier Factor(dB)
3. The other emission levels were very low against the limit.
4. Margin value = Emission Level – Limit value
5. " * ": Fundamental frequency.
6. " # ": The radiated frequency is out of the restricted band.



A D T

CHANNEL	TX Channel 140	DETECTOR FUNCTION	Peak (PK)
FREQUENCY RANGE	1GHz ~ 40GHz		Average (AV)

ANTENNA POLARITY & TEST DISTANCE: HORIZONTAL AT 3 M

NO.	FREQ. (MHz)	EMISSION LEVEL (dBuV/m)	LIMIT (dBuV/m)	MARGIN (dB)	ANTENNA HEIGHT (m)	TABLE ANGLE (Degree)	RAW VALUE (dBuV)	CORRECTION FACTOR (dB/m)
1	*5700.00	104.0 PK			1.08 H	166	99.51	4.49
2	*5700.00	94.4 AV			1.08 H	166	89.91	4.49
3	#5725.00	68.3 PK	74.0	-5.7	1.07 H	149	63.80	4.50
4	#5725.00	50.1 AV	54.0	-3.9	1.07 H	149	45.60	4.50
5	11400.00	60.0 PK	74.0	-14.0	1.17 H	61	50.03	9.97
6	11400.00	47.4 AV	54.0	-6.6	1.17 H	61	37.43	9.97
7	#17100.00	61.1 PK	74.0	-12.9	1.06 H	301	43.38	17.72
8	#17100.00	49.4 AV	54.0	-4.6	1.06 H	301	31.68	17.72

ANTENNA POLARITY & TEST DISTANCE: VERTICAL AT 3 M

NO.	FREQ. (MHz)	EMISSION LEVEL (dBuV/m)	LIMIT (dBuV/m)	MARGIN (dB)	ANTENNA HEIGHT (m)	TABLE ANGLE (Degree)	RAW VALUE (dBuV)	CORRECTION FACTOR (dB/m)
1	*5700.00	115.8 PK			1.02 V	132	111.31	4.49
2	*5700.00	105.5 AV			1.02 V	132	101.01	4.49
3	#5725.00	69.2 PK	74.0	-4.8	1.02 V	132	64.70	4.50
4	#5725.00	53.3 AV	54.0	-0.7	1.02 V	132	48.80	4.50
5	11400.00	61.9 PK	74.0	-12.1	1.04 V	35	51.93	9.97
6	11400.00	47.0 AV	54.0	-7.0	1.04 V	35	37.03	9.97
7	#17100.00	65.1 PK	74.0	-8.9	1.01 V	25	47.38	17.72
8	#17100.00	52.2 AV	54.0	-1.8	1.01 V	25	34.48	17.72

REMARKS:

1. Emission Level(dBuV/m) = Raw Value(dBuV) + Correction Factor(dB/m)
2. Correction Factor(dB/m) = Antenna Factor(dB/m) + Cable Factor(dB) – Pre-Amplifier Factor(dB)
3. The other emission levels were very low against the limit.
4. Margin value = Emission Level – Limit value
5. " * ": Fundamental frequency.
6. " # ": The radiated frequency is out of the restricted band.



A D T

802.11ac (VHT20)

CHANNEL	TX Channel 52	DETECTOR FUNCTION	Peak (PK)
FREQUENCY RANGE	1GHz ~ 40GHz		Average (AV)

ANTENNA POLARITY & TEST DISTANCE: HORIZONTAL AT 3 M

NO.	FREQ. (MHz)	EMISSION LEVEL (dBuV/m)	LIMIT (dBuV/m)	MARGIN (dB)	ANTENNA HEIGHT (m)	TABLE ANGLE (Degree)	RAW VALUE (dBuV)	CORRECTION FACTOR (dB/m)
1	5150.00	51.5 PK	74.0	-22.5	1.11 H	154	47.66	3.84
2	5150.00	39.3 AV	54.0	-14.7	1.11 H	154	35.46	3.84
3	*5260.00	111.3 PK			1.11 H	154	107.35	3.95
4	*5260.00	103.1 AV			1.11 H	154	99.15	3.95
5	5350.00	53.2 PK	74.0	-20.8	1.11 H	154	49.13	4.07
6	5350.00	41.3 AV	54.0	-12.7	1.11 H	154	37.23	4.07
7	#10520.00	63.2 PK	74.0	-10.8	1.17 H	59	53.42	9.78
8	#10520.00	50.0 AV	54.0	-4.0	1.17 H	59	40.22	9.78
9	15780.00	65.2 PK	74.0	-8.8	1.00 H	306	51.27	13.93
10	15780.00	52.8 AV	54.0	-1.2	1.00 H	306	38.87	13.93

ANTENNA POLARITY & TEST DISTANCE: VERTICAL AT 3 M

NO.	FREQ. (MHz)	EMISSION LEVEL (dBuV/m)	LIMIT (dBuV/m)	MARGIN (dB)	ANTENNA HEIGHT (m)	TABLE ANGLE (Degree)	RAW VALUE (dBuV)	CORRECTION FACTOR (dB/m)
1	5150.00	55.9 PK	74.0	-18.1	1.37 V	132	52.06	3.84
2	5150.00	44.3 AV	54.0	-9.7	1.37 V	132	40.46	3.84
3	*5260.00	123.4 PK			1.39 V	126	119.45	3.95
4	*5260.00	115.5 AV			1.39 V	126	111.55	3.95
5	5350.00	56.4 PK	74.0	-17.6	1.43 V	124	52.33	4.07
6	5350.00	45.0 AV	54.0	-9.0	1.43 V	124	40.93	4.07
7	#10520.00	62.9 PK	74.0	-11.1	1.02 V	2	53.12	9.78
8	#10520.00	49.5 AV	54.0	-4.5	1.02 V	2	39.72	9.78
9	15780.00	66.3 PK	74.0	-7.7	1.07 V	18	52.37	13.93
10	15780.00	53.4 AV	54.0	-0.6	1.07 V	18	39.47	13.93

REMARKS:

1. Emission Level(dBuV/m) = Raw Value(dBuV) + Correction Factor(dB/m)
2. Correction Factor(dB/m) = Antenna Factor(dB/m) + Cable Factor(dB) – Pre-Amplifier Factor(dB)
3. The other emission levels were very low against the limit.
4. Margin value = Emission Level – Limit value
5. " * ": Fundamental frequency.
6. " # ": The radiated frequency is out of the restricted band.



A D T

CHANNEL	TX Channel 60	DETECTOR FUNCTION	Peak (PK)
FREQUENCY RANGE	1GHz ~ 40GHz		Average (AV)

ANTENNA POLARITY & TEST DISTANCE: HORIZONTAL AT 3 M

NO.	FREQ. (MHz)	EMISSION LEVEL (dBuV/m)	LIMIT (dBuV/m)	MARGIN (dB)	ANTENNA HEIGHT (m)	TABLE ANGLE (Degree)	RAW VALUE (dBuV)	CORRECTION FACTOR (dB/m)
1	*5300.00	104.9 PK			1.04 H	145	100.96	3.94
2	*5300.00	95.2 AV			1.04 H	145	91.26	3.94
3	10600.00	60.5 PK	74.0	-13.5	1.28 H	53	50.43	10.07
4	10600.00	47.5 AV	54.0	-6.5	1.28 H	53	37.43	10.07
5	15900.00	62.3 PK	74.0	-11.7	1.05 H	295	48.08	14.22
6	15900.00	50.4 AV	54.0	-3.6	1.05 H	295	36.18	14.22

ANTENNA POLARITY & TEST DISTANCE: VERTICAL AT 3 M

NO.	FREQ. (MHz)	EMISSION LEVEL (dBuV/m)	LIMIT (dBuV/m)	MARGIN (dB)	ANTENNA HEIGHT (m)	TABLE ANGLE (Degree)	RAW VALUE (dBuV)	CORRECTION FACTOR (dB/m)
1	*5300.00	116.8 PK			1.42 V	92	112.86	3.94
2	*5300.00	107.0 AV			1.42 V	92	103.06	3.94
3	10600.00	61.6 PK	74.0	-12.4	1.03 V	15	51.53	10.07
4	10600.00	46.8 AV	54.0	-7.2	1.03 V	15	36.73	10.07
5	15900.00	64.4 PK	74.0	-9.6	1.04 V	11	50.18	14.22
6	15900.00	51.3 AV	54.0	-2.7	1.04 V	11	37.08	14.22

REMARKS:

1. Emission Level(dBuV/m) = Raw Value(dBuV) + Correction Factor(dB/m)
2. Correction Factor(dB/m) = Antenna Factor(dB/m) + Cable Factor(dB) – Pre-Amplifier Factor(dB)
3. The other emission levels were very low against the limit.
4. Margin value = Emission Level – Limit value
5. " * ": Fundamental frequency.



A D T

CHANNEL	TX Channel 64	DETECTOR FUNCTION	Peak (PK)
FREQUENCY RANGE	1GHz ~ 40GHz		Average (AV)

ANTENNA POLARITY & TEST DISTANCE: HORIZONTAL AT 3 M

NO.	FREQ. (MHz)	EMISSION LEVEL (dBuV/m)	LIMIT (dBuV/m)	MARGIN (dB)	ANTENNA HEIGHT (m)	TABLE ANGLE (Degree)	RAW VALUE (dBuV)	CORRECTION FACTOR (dB/m)
1	*5320.00	105.2 PK			1.04 H	130	101.21	3.99
2	*5320.00	95.4 AV			1.04 H	130	91.41	3.99
3	5350.00	66.5 PK	74.0	-7.5	1.04 H	130	62.43	4.07
4	5350.00	50.4 AV	54.0	-3.6	1.04 H	130	46.33	4.07
5	10640.00	60.4 PK	74.0	-13.6	1.26 H	43	50.39	10.01
6	10640.00	47.3 AV	54.0	-6.7	1.26 H	43	37.29	10.01
7	15960.00	62.4 PK	74.0	-11.6	1.10 H	289	48.25	14.15
8	15960.00	50.5 AV	54.0	-3.5	1.10 H	289	36.35	14.15

ANTENNA POLARITY & TEST DISTANCE: VERTICAL AT 3 M

NO.	FREQ. (MHz)	EMISSION LEVEL (dBuV/m)	LIMIT (dBuV/m)	MARGIN (dB)	ANTENNA HEIGHT (m)	TABLE ANGLE (Degree)	RAW VALUE (dBuV)	CORRECTION FACTOR (dB/m)
1	*5320.00	117.7 PK			1.03 V	192	113.71	3.99
2	*5320.00	106.3 AV			1.03 V	192	102.31	3.99
3	5350.00	69.2 PK	74.0	-4.8	1.03 V	192	65.13	4.07
4	5350.00	52.8 AV	54.0	-1.2	1.03 V	192	48.73	4.07
5	10640.00	61.8 PK	74.0	-12.2	1.00 V	9	51.79	10.01
6	10640.00	46.8 AV	54.0	-7.2	1.00 V	9	36.79	10.01
7	15960.00	64.9 PK	74.0	-9.1	1.04 V	14	50.75	14.15
8	15960.00	51.7 AV	54.0	-2.3	1.04 V	14	37.55	14.15

REMARKS:

1. Emission Level(dBuV/m) = Raw Value(dBuV) + Correction Factor(dB/m)
2. Correction Factor(dB/m) = Antenna Factor(dB/m) + Cable Factor(dB) – Pre-Amplifier Factor(dB)
3. The other emission levels were very low against the limit.
4. Margin value = Emission Level – Limit value
5. " * ": Fundamental frequency.



A D T

CHANNEL	TX Channel 100	DETECTOR FUNCTION	Peak (PK)
FREQUENCY RANGE	1GHz ~ 40GHz		Average (AV)

ANTENNA POLARITY & TEST DISTANCE: HORIZONTAL AT 3 M

NO.	FREQ. (MHz)	EMISSION LEVEL (dBuV/m)	LIMIT (dBuV/m)	MARGIN (dB)	ANTENNA HEIGHT (m)	TABLE ANGLE (Degree)	RAW VALUE (dBuV)	CORRECTION FACTOR (dB/m)
1	#5470.00	66.5 PK	74.0	-7.5	1.05 H	132	62.33	4.17
2	#5470.00	50.3 AV	54.0	-3.7	1.05 H	132	46.13	4.17
3	*5500.00	104.3 PK			1.07 H	145	100.14	4.16
4	*5500.00	94.5 AV			1.07 H	145	90.34	4.16
5	11000.00	59.7 PK	74.0	-14.3	1.23 H	57	49.47	10.23
6	11000.00	46.8 AV	54.0	-7.2	1.23 H	57	36.57	10.23
7	#16500.00	62.8 PK	74.0	-11.2	1.11 H	290	46.60	16.20
8	#16500.00	50.6 AV	54.0	-3.4	1.11 H	290	34.40	16.20

ANTENNA POLARITY & TEST DISTANCE: VERTICAL AT 3 M

NO.	FREQ. (MHz)	EMISSION LEVEL (dBuV/m)	LIMIT (dBuV/m)	MARGIN (dB)	ANTENNA HEIGHT (m)	TABLE ANGLE (Degree)	RAW VALUE (dBuV)	CORRECTION FACTOR (dB/m)
1	#5470.00	71.4 PK	74.0	-2.6	1.01 V	190	67.23	4.17
2	#5470.00	52.7 AV	54.0	-1.3	1.01 V	190	48.53	4.17
3	*5500.00	117.1 PK			1.01 V	190	112.94	4.16
4	*5500.00	105.7 AV			1.01 V	190	101.54	4.16
5	11000.00	61.4 PK	74.0	-12.6	1.05 V	12	51.17	10.23
6	11000.00	46.3 AV	54.0	-7.7	1.05 V	12	36.07	10.23
7	#16500.00	65.1 PK	74.0	-8.9	1.09 V	15	48.90	16.20
8	#16500.00	51.7 AV	54.0	-2.3	1.09 V	15	35.50	16.20

REMARKS:

1. Emission Level(dBuV/m) = Raw Value(dBuV) + Correction Factor(dB/m)
2. Correction Factor(dB/m) = Antenna Factor(dB/m) + Cable Factor(dB) – Pre-Amplifier Factor(dB)
3. The other emission levels were very low against the limit.
4. Margin value = Emission Level – Limit value
5. " * ": Fundamental frequency.
6. " # ": The radiated frequency is out of the restricted band.



A D T

CHANNEL	TX Channel 116	DETECTOR FUNCTION	Peak (PK)
FREQUENCY RANGE	1GHz ~ 40GHz		Average (AV)

ANTENNA POLARITY & TEST DISTANCE: HORIZONTAL AT 3 M

NO.	FREQ. (MHz)	EMISSION LEVEL (dBuV/m)	LIMIT (dBuV/m)	MARGIN (dB)	ANTENNA HEIGHT (m)	TABLE ANGLE (Degree)	RAW VALUE (dBuV)	CORRECTION FACTOR (dB/m)
1	*5580.00	109.2 PK			1.10 H	151	104.77	4.43
2	*5580.00	101.5 AV			1.10 H	151	97.07	4.43
3	11160.00	63.2 PK	74.0	-10.8	1.19 H	51	53.09	10.11
4	11160.00	50.3 AV	54.0	-3.7	1.19 H	51	40.19	10.11
5	#16740.00	65.2 PK	74.0	-8.8	1.00 H	306	48.11	17.09
6	#16740.00	52.6 AV	54.0	-1.4	1.00 H	306	35.51	17.09

ANTENNA POLARITY & TEST DISTANCE: VERTICAL AT 3 M

NO.	FREQ. (MHz)	EMISSION LEVEL (dBuV/m)	LIMIT (dBuV/m)	MARGIN (dB)	ANTENNA HEIGHT (m)	TABLE ANGLE (Degree)	RAW VALUE (dBuV)	CORRECTION FACTOR (dB/m)
1	*5580.00	122.3 PK			1.35 V	130	117.87	4.43
2	*5580.00	114.6 AV			1.35 V	130	110.17	4.43
3	11160.00	62.2 PK	74.0	-11.8	1.00 V	12	52.09	10.11
4	11160.00	49.1 AV	54.0	-4.9	1.00 V	12	38.99	10.11
5	#16740.00	66.7 PK	74.0	-7.3	1.08 V	21	49.61	17.09
6	#16740.00	53.3 AV	54.0	-0.7	1.08 V	21	36.21	17.09

REMARKS:

1. Emission Level(dBuV/m) = Raw Value(dBuV) + Correction Factor(dB/m)
2. Correction Factor(dB/m) = Antenna Factor(dB/m) + Cable Factor(dB) – Pre-Amplifier Factor(dB)
3. The other emission levels were very low against the limit.
4. Margin value = Emission Level – Limit value
5. " * ": Fundamental frequency.
6. " # ": The radiated frequency is out of the restricted band.



A D T

CHANNEL	TX Channel 132	DETECTOR FUNCTION	Peak (PK)
FREQUENCY RANGE	1GHz ~ 40GHz		Average (AV)

ANTENNA POLARITY & TEST DISTANCE: HORIZONTAL AT 3 M

NO.	FREQ. (MHz)	EMISSION LEVEL (dBuV/m)	LIMIT (dBuV/m)	MARGIN (dB)	ANTENNA HEIGHT (m)	TABLE ANGLE (Degree)	RAW VALUE (dBuV)	CORRECTION FACTOR (dB/m)
1	*5660.00	109.7 PK			1.07 H	162	105.20	4.50
2	*5660.00	102.0 AV			1.07 H	162	97.50	4.50
3	11320.00	63.6 PK	74.0	-10.4	1.23 H	61	53.45	10.15
4	11320.00	50.6 AV	54.0	-3.4	1.23 H	61	40.45	10.15
5	#16980.00	65.0 PK	74.0	-9.0	1.03 H	319	47.41	17.59
6	#16980.00	52.6 AV	54.0	-1.4	1.03 H	319	35.01	17.59

ANTENNA POLARITY & TEST DISTANCE: VERTICAL AT 3 M

NO.	FREQ. (MHz)	EMISSION LEVEL (dBuV/m)	LIMIT (dBuV/m)	MARGIN (dB)	ANTENNA HEIGHT (m)	TABLE ANGLE (Degree)	RAW VALUE (dBuV)	CORRECTION FACTOR (dB/m)
1	*5660.00	121.8 PK			1.31 V	143	117.30	4.50
2	*5660.00	114.1 AV			1.31 V	143	109.60	4.50
3	11320.00	62.9 PK	74.0	-11.1	1.02 V	13	52.75	10.15
4	11320.00	49.6 AV	54.0	-4.4	1.02 V	13	39.45	10.15
5	#16980.00	66.5 PK	74.0	-7.5	1.09 V	36	48.91	17.59
6	#16980.00	53.1 AV	54.0	-0.9	1.09 V	36	35.51	17.59

REMARKS:

1. Emission Level(dBuV/m) = Raw Value(dBuV) + Correction Factor(dB/m)
2. Correction Factor(dB/m) = Antenna Factor(dB/m) + Cable Factor(dB) – Pre-Amplifier Factor(dB)
3. The other emission levels were very low against the limit.
4. Margin value = Emission Level – Limit value
5. " * ": Fundamental frequency.
6. " # ": The radiated frequency is out of the restricted band.



A D T

CHANNEL	TX Channel 140	DETECTOR FUNCTION	Peak (PK)
FREQUENCY RANGE	1GHz ~ 40GHz		Average (AV)

ANTENNA POLARITY & TEST DISTANCE: HORIZONTAL AT 3 M

NO.	FREQ. (MHz)	EMISSION LEVEL (dBuV/m)	LIMIT (dBuV/m)	MARGIN (dB)	ANTENNA HEIGHT (m)	TABLE ANGLE (Degree)	RAW VALUE (dBuV)	CORRECTION FACTOR (dB/m)
1	*5700.00	103.5 PK			1.07 H	166	99.01	4.49
2	*5700.00	94.0 AV			1.07 H	166	89.51	4.49
3	#5725.00	68.2 PK	74.0	-5.8	1.07 H	166	63.70	4.50
4	#5725.00	49.7 AV	54.0	-4.3	1.07 H	166	45.20	4.50
5	11400.00	60.0 PK	74.0	-14.0	1.21 H	69	50.03	9.97
6	11400.00	47.5 AV	54.0	-6.5	1.21 H	69	37.53	9.97
7	#17100.00	61.3 PK	74.0	-12.7	1.11 H	303	43.58	17.72
8	#17100.00	49.4 AV	54.0	-4.6	1.11 H	303	31.68	17.72

ANTENNA POLARITY & TEST DISTANCE: VERTICAL AT 3 M

NO.	FREQ. (MHz)	EMISSION LEVEL (dBuV/m)	LIMIT (dBuV/m)	MARGIN (dB)	ANTENNA HEIGHT (m)	TABLE ANGLE (Degree)	RAW VALUE (dBuV)	CORRECTION FACTOR (dB/m)
1	*5700.00	117.4 PK			1.52 V	143	112.91	4.49
2	*5700.00	105.3 AV			1.52 V	143	100.81	4.49
3	#5725.00	69.4 PK	74.0	-4.6	1.52 V	143	64.90	4.50
4	#5725.00	52.2 AV	54.0	-1.8	1.52 V	143	47.70	4.50
5	11400.00	61.1 PK	74.0	-12.9	1.04 V	23	51.13	9.97
6	11400.00	46.7 AV	54.0	-7.3	1.04 V	23	36.73	9.97
7	#17100.00	65.4 PK	74.0	-8.6	1.07 V	6	47.68	17.72
8	#17100.00	52.0 AV	54.0	-2.0	1.07 V	6	34.28	17.72

REMARKS:

1. Emission Level(dBuV/m) = Raw Value(dBuV) + Correction Factor(dB/m)
2. Correction Factor(dB/m) = Antenna Factor(dB/m) + Cable Factor(dB) – Pre-Amplifier Factor(dB)
3. The other emission levels were very low against the limit.
4. Margin value = Emission Level – Limit value
5. " * ": Fundamental frequency.
6. " # ": The radiated frequency is out of the restricted band.



A D T

802.11ac (VHT40)

CHANNEL	TX Channel 54	DETECTOR FUNCTION	Peak (PK)
FREQUENCY RANGE	1GHz ~ 40GHz		Average (AV)

ANTENNA POLARITY & TEST DISTANCE: HORIZONTAL AT 3 M

NO.	FREQ. (MHz)	EMISSION LEVEL (dBuV/m)	LIMIT (dBuV/m)	MARGIN (dB)	ANTENNA HEIGHT (m)	TABLE ANGLE (Degree)	RAW VALUE (dBuV)	CORRECTION FACTOR (dB/m)
1	*5270.00	102.3 PK			1.00 H	124	98.36	3.94
2	*5270.00	91.9 AV			1.00 H	124	87.96	3.94
3	#10540.00	62.3 PK	74.0	-11.7	1.25 H	89	52.44	9.86
4	#10540.00	47.7 AV	54.0	-6.3	1.25 H	89	37.84	9.86
5	15810.00	63.6 PK	74.0	-10.4	1.11 H	297	49.62	13.98
6	15810.00	52.3 AV	54.0	-1.7	1.11 H	297	38.32	13.98

ANTENNA POLARITY & TEST DISTANCE: VERTICAL AT 3 M

NO.	FREQ. (MHz)	EMISSION LEVEL (dBuV/m)	LIMIT (dBuV/m)	MARGIN (dB)	ANTENNA HEIGHT (m)	TABLE ANGLE (Degree)	RAW VALUE (dBuV)	CORRECTION FACTOR (dB/m)
1	*5270.00	113.3 PK			1.02 V	178	109.36	3.94
2	*5270.00	102.8 AV			1.02 V	178	98.86	3.94
3	#10540.00	61.0 PK	74.0	-13.0	1.05 V	1	51.14	9.86
4	#10540.00	46.5 AV	54.0	-7.5	1.05 V	1	36.64	9.86
5	15810.00	65.4 PK	74.0	-8.6	1.05 V	9	51.42	13.98
6	15810.00	51.9 AV	54.0	-2.1	1.05 V	9	37.92	13.98

REMARKS:

1. Emission Level(dBuV/m) = Raw Value(dBuV) + Correction Factor(dB/m)
2. Correction Factor(dB/m) = Antenna Factor(dB/m) + Cable Factor(dB) – Pre-Amplifier Factor(dB)
3. The other emission levels were very low against the limit.
4. Margin value = Emission Level – Limit value
5. " * ": Fundamental frequency.
6. " # ": The radiated frequency is out of the restricted band.



A D T

CHANNEL	TX Channel 62	DETECTOR FUNCTION	Peak (PK)
FREQUENCY RANGE	1GHz ~ 40GHz		Average (AV)

ANTENNA POLARITY & TEST DISTANCE: HORIZONTAL AT 3 M

NO.	FREQ. (MHz)	EMISSION LEVEL (dBuV/m)	LIMIT (dBuV/m)	MARGIN (dB)	ANTENNA HEIGHT (m)	TABLE ANGLE (Degree)	RAW VALUE (dBuV)	CORRECTION FACTOR (dB/m)
1	*5310.00	101.0 PK			1.02 H	124	97.04	3.96
2	*5310.00	89.6 AV			1.02 H	124	85.64	3.96
3	5350.00	63.1 PK	74.0	-10.9	1.02 H	124	59.03	4.07
4	5350.00	48.3 AV	54.0	-5.7	1.02 H	124	44.23	4.07
5	10620.00	62.3 PK	74.0	-11.7	1.25 H	89	52.27	10.03
6	10620.00	47.7 AV	54.0	-6.3	1.25 H	89	37.67	10.03
7	15930.00	63.6 PK	74.0	-10.4	1.11 H	297	49.42	14.18
8	15930.00	51.8 AV	54.0	-2.2	1.11 H	297	37.62	14.18

ANTENNA POLARITY & TEST DISTANCE: VERTICAL AT 3 M

NO.	FREQ. (MHz)	EMISSION LEVEL (dBuV/m)	LIMIT (dBuV/m)	MARGIN (dB)	ANTENNA HEIGHT (m)	TABLE ANGLE (Degree)	RAW VALUE (dBuV)	CORRECTION FACTOR (dB/m)
1	*5310.00	112.3 PK			1.04 V	178	108.34	3.96
2	*5310.00	100.6 AV			1.04 V	178	96.64	3.96
3	5350.00	65.6 PK	74.0	-8.4	1.04 V	178	61.53	4.07
4	5350.00	51.9 AV	54.0	-2.1	1.04 V	178	47.83	4.07
5	10620.00	60.9 PK	74.0	-13.1	1.10 V	5	50.87	10.03
6	10620.00	46.2 AV	54.0	-7.8	1.10 V	5	36.17	10.03
7	15930.00	66.0 PK	74.0	-8.0	1.07 V	5	51.82	14.18
8	15930.00	52.2 AV	54.0	-1.8	1.07 V	5	38.02	14.18

REMARKS:

1. Emission Level(dBuV/m) = Raw Value(dBuV) + Correction Factor(dB/m)
2. Correction Factor(dB/m) = Antenna Factor(dB/m) + Cable Factor(dB) – Pre-Amplifier Factor(dB)
3. The other emission levels were very low against the limit.
4. Margin value = Emission Level – Limit value
5. " * ": Fundamental frequency.



A D T

CHANNEL	TX Channel 102	DETECTOR FUNCTION	Peak (PK)
FREQUENCY RANGE	1GHz ~ 40GHz		Average (AV)

ANTENNA POLARITY & TEST DISTANCE: HORIZONTAL AT 3 M

NO.	FREQ. (MHz)	EMISSION LEVEL (dBuV/m)	LIMIT (dBuV/m)	MARGIN (dB)	ANTENNA HEIGHT (m)	TABLE ANGLE (Degree)	RAW VALUE (dBuV)	CORRECTION FACTOR (dB/m)
1	#5470.00	67.2 PK	74.0	-6.8	1.10 H	169	63.03	4.17
2	#5470.00	49.8 AV	54.0	-4.2	1.10 H	169	45.63	4.17
3	*5510.00	98.4 PK			1.03 H	154	94.20	4.20
4	*5510.00	86.3 AV			1.03 H	154	82.10	4.20
5	11020.00	61.7 PK	74.0	-12.3	1.20 H	80	51.50	10.20
6	11020.00	47.4 AV	54.0	-6.6	1.20 H	80	37.20	10.20
7	#16530.00	63.4 PK	74.0	-10.6	1.12 H	300	47.13	16.27
8	#16530.00	51.6 AV	54.0	-2.4	1.12 H	300	35.33	16.27

ANTENNA POLARITY & TEST DISTANCE: VERTICAL AT 3 M

NO.	FREQ. (MHz)	EMISSION LEVEL (dBuV/m)	LIMIT (dBuV/m)	MARGIN (dB)	ANTENNA HEIGHT (m)	TABLE ANGLE (Degree)	RAW VALUE (dBuV)	CORRECTION FACTOR (dB/m)
1	#5470.00	68.1 PK	74.0	-5.9	1.00 V	189	63.93	4.17
2	#5470.00	52.7 AV	54.0	-1.3	1.00 V	189	48.53	4.17
3	*5510.00	109.6 PK			1.00 V	189	105.40	4.20
4	*5510.00	98.6 AV			1.00 V	189	94.40	4.20
5	11020.00	60.5 PK	74.0	-13.5	1.05 V	20	50.30	10.20
6	11020.00	45.2 AV	54.0	-8.8	1.05 V	20	35.00	10.20
7	#16530.00	64.7 PK	74.0	-9.3	1.12 V	20	48.43	16.27
8	#16530.00	51.6 AV	54.0	-2.4	1.12 V	20	35.33	16.27

REMARKS:

1. Emission Level(dBuV/m) = Raw Value(dBuV) + Correction Factor(dB/m)
2. Correction Factor(dB/m) = Antenna Factor(dB/m) + Cable Factor(dB) – Pre-Amplifier Factor(dB)
3. The other emission levels were very low against the limit.
4. Margin value = Emission Level – Limit value
5. " * ": Fundamental frequency.
6. " # ": The radiated frequency is out of the restricted band.



A D T

CHANNEL	TX Channel 110	DETECTOR FUNCTION	Peak (PK)
FREQUENCY RANGE	1GHz ~ 40GHz		Average (AV)

ANTENNA POLARITY & TEST DISTANCE: HORIZONTAL AT 3 M

NO.	FREQ. (MHz)	EMISSION LEVEL (dBuV/m)	LIMIT (dBuV/m)	MARGIN (dB)	ANTENNA HEIGHT (m)	TABLE ANGLE (Degree)	RAW VALUE (dBuV)	CORRECTION FACTOR (dB/m)
1	#5470.00	68.9 PK	74.0	-5.1	1.03 H	140	64.73	4.17
2	#5470.00	50.5 AV	54.0	-3.5	1.03 H	140	46.33	4.17
3	*5550.00	102.8 PK			1.03 H	140	98.47	4.33
4	*5550.00	92.3 AV			1.03 H	140	87.97	4.33
5	11100.00	62.3 PK	74.0	-11.7	1.20 H	93	52.23	10.07
6	11100.00	47.7 AV	54.0	-6.3	1.20 H	93	37.63	10.07
7	#16650.00	63.6 PK	74.0	-10.4	1.12 H	298	46.95	16.65
8	#16650.00	52.0 AV	54.0	-2.0	1.12 H	298	35.35	16.65

ANTENNA POLARITY & TEST DISTANCE: VERTICAL AT 3 M

NO.	FREQ. (MHz)	EMISSION LEVEL (dBuV/m)	LIMIT (dBuV/m)	MARGIN (dB)	ANTENNA HEIGHT (m)	TABLE ANGLE (Degree)	RAW VALUE (dBuV)	CORRECTION FACTOR (dB/m)
1	#5470.00	71.1 PK	74.0	-2.9	1.00 V	188	66.93	4.17
2	#5470.00	53.2 AV	54.0	-0.8	1.00 V	188	49.03	4.17
3	*5550.00	114.0 PK			1.00 V	188	109.67	4.33
4	*5550.00	103.3 AV			1.00 V	188	98.97	4.33
5	11100.00	61.0 PK	74.0	-13.0	1.00 V	14	50.93	10.07
6	11100.00	46.5 AV	54.0	-7.5	1.00 V	14	36.43	10.07
7	#16650.00	65.5 PK	74.0	-8.5	1.05 V	7	48.85	16.65
8	#16650.00	51.9 AV	54.0	-2.1	1.05 V	7	35.25	16.65

REMARKS:

1. Emission Level(dBuV/m) = Raw Value(dBuV) + Correction Factor(dB/m)
2. Correction Factor(dB/m) = Antenna Factor(dB/m) + Cable Factor(dB) – Pre-Amplifier Factor(dB)
3. The other emission levels were very low against the limit.
4. Margin value = Emission Level – Limit value
5. " * ": Fundamental frequency.
6. " # ": The radiated frequency is out of the restricted band.



A D T

CHANNEL	TX Channel 134	DETECTOR FUNCTION	Peak (PK)
FREQUENCY RANGE	1GHz ~ 40GHz		Average (AV)

ANTENNA POLARITY & TEST DISTANCE: HORIZONTAL AT 3 M

NO.	FREQ. (MHz)	EMISSION LEVEL (dBuV/m)	LIMIT (dBuV/m)	MARGIN (dB)	ANTENNA HEIGHT (m)	TABLE ANGLE (Degree)	RAW VALUE (dBuV)	CORRECTION FACTOR (dB/m)
1	*5670.00	101.4 PK			1.08 H	144	96.90	4.50
2	*5670.00	88.3 AV			1.08 H	144	83.80	4.50
3	#5725.00	67.3 PK	74.0	-6.7	1.08 H	144	62.80	4.50
4	#5725.00	51.4 AV	54.0	-2.6	1.08 H	144	46.90	4.50
5	11340.00	62.4 PK	74.0	-11.6	1.21 H	75	52.30	10.10
6	11340.00	48.0 AV	54.0	-6.0	1.21 H	75	37.90	10.10
7	#17010.00	64.1 PK	74.0	-9.9	1.21 H	303	46.50	17.60
8	#17010.00	51.6 AV	54.0	-2.4	1.21 H	303	34.00	17.60

ANTENNA POLARITY & TEST DISTANCE: VERTICAL AT 3 M

NO.	FREQ. (MHz)	EMISSION LEVEL (dBuV/m)	LIMIT (dBuV/m)	MARGIN (dB)	ANTENNA HEIGHT (m)	TABLE ANGLE (Degree)	RAW VALUE (dBuV)	CORRECTION FACTOR (dB/m)
1	*5670.00	114.1 PK			1.50 V	141	109.60	4.50
2	*5670.00	102.1 AV			1.50 V	141	97.60	4.50
3	#5725.00	69.5 PK	74.0	-4.5	1.50 V	141	65.00	4.50
4	#5725.00	53.5 AV	54.0	-0.5	1.50 V	141	49.00	4.50
5	11340.00	61.1 PK	74.0	-12.9	1.09 V	6	51.00	10.10
6	11340.00	46.5 AV	54.0	-7.5	1.09 V	6	36.40	10.10
7	#17010.00	66.1 PK	74.0	-7.9	1.06 V	15	48.50	17.60
8	#17010.00	52.1 AV	54.0	-1.9	1.06 V	15	34.50	17.60

REMARKS:

1. Emission Level(dBuV/m) = Raw Value(dBuV) + Correction Factor(dB/m)
2. Correction Factor(dB/m) = Antenna Factor(dB/m) + Cable Factor(dB) – Pre-Amplifier Factor(dB)
3. The other emission levels were very low against the limit.
4. Margin value = Emission Level – Limit value
5. " * ": Fundamental frequency.
6. " # ": The radiated frequency is out of the restricted band.



A D T

802.11ac (VHT80)

CHANNEL	TX Channel 58	DETECTOR FUNCTION	Peak (PK)
FREQUENCY RANGE	1GHz ~ 40GHz		Average (AV)

ANTENNA POLARITY & TEST DISTANCE: HORIZONTAL AT 3 M

NO.	FREQ. (MHz)	EMISSION LEVEL (dBuV/m)	LIMIT (dBuV/m)	MARGIN (dB)	ANTENNA HEIGHT (m)	TABLE ANGLE (Degree)	RAW VALUE (dBuV)	CORRECTION FACTOR (dB/m)
1	*5290.00	98.3 PK			1.08 H	147	94.36	3.94
2	*5290.00	85.4 AV			1.08 H	147	81.46	3.94
3	5350.00	68.4 PK	74.0	-5.6	1.12 H	163	64.33	4.07
4	5350.00	50.3 AV	54.0	-3.7	1.12 H	163	46.23	4.07
5	#10580.00	61.6 PK	74.0	-12.4	1.20 H	90	51.59	10.01
6	#10580.00	47.1 AV	54.0	-6.9	1.20 H	90	37.09	10.01
7	15870.00	63.6 PK	74.0	-10.4	1.10 H	287	49.46	14.14
8	15870.00	51.9 AV	54.0	-2.1	1.10 H	287	37.76	14.14

ANTENNA POLARITY & TEST DISTANCE: VERTICAL AT 3 M

NO.	FREQ. (MHz)	EMISSION LEVEL (dBuV/m)	LIMIT (dBuV/m)	MARGIN (dB)	ANTENNA HEIGHT (m)	TABLE ANGLE (Degree)	RAW VALUE (dBuV)	CORRECTION FACTOR (dB/m)
1	*5290.00	109.5 PK			1.05 V	190	105.56	3.94
2	*5290.00	97.9 AV			1.05 V	190	93.96	3.94
3	5350.00	68.5 PK	74.0	-5.5	1.01 V	201	64.43	4.07
4	5350.00	53.0 AV	54.0	-1.0	1.01 V	201	48.93	4.07
5	#10580.00	61.4 PK	74.0	-12.6	1.00 V	33	51.39	10.01
6	#10580.00	47.3 AV	54.0	-6.7	1.00 V	33	37.29	10.01
7	15870.00	64.4 PK	74.0	-9.6	1.11 V	29	50.26	14.14
8	15870.00	51.8 AV	54.0	-2.2	1.11 V	29	37.66	14.14

REMARKS:

1. Emission Level(dBuV/m) = Raw Value(dBuV) + Correction Factor(dB/m)
2. Correction Factor(dB/m) = Antenna Factor(dB/m) + Cable Factor(dB) – Pre-Amplifier Factor(dB)
3. The other emission levels were very low against the limit.
4. Margin value = Emission Level – Limit value
5. " * ": Fundamental frequency.
6. " # ": The radiated frequency is out of the restricted band.



A D T

CHANNEL	TX Channel 106	DETECTOR FUNCTION	Peak (PK)
FREQUENCY RANGE	1GHz ~ 40GHz		Average (AV)

ANTENNA POLARITY & TEST DISTANCE: HORIZONTAL AT 3 M

NO.	FREQ. (MHz)	EMISSION LEVEL (dBuV/m)	LIMIT (dBuV/m)	MARGIN (dB)	ANTENNA HEIGHT (m)	TABLE ANGLE (Degree)	RAW VALUE (dBuV)	CORRECTION FACTOR (dB/m)
1	#5470.00	68.7 PK	74.0	-5.3	1.12 H	182	64.53	4.17
2	#5470.00	50.6 AV	54.0	-3.4	1.12 H	182	46.43	4.17
3	*5530.00	95.3 PK			1.06 H	154	91.04	4.26
4	*5530.00	81.3 AV			1.06 H	154	77.04	4.26
5	11060.00	62.2 PK	74.0	-11.8	1.30 H	93	52.07	10.13
6	11060.00	46.2 AV	54.0	-7.8	1.30 H	93	36.07	10.13
7	#16590.00	62.7 PK	74.0	-11.3	1.09 H	294	46.28	16.42
8	#16590.00	50.7 AV	54.0	-3.3	1.09 H	294	34.28	16.42

ANTENNA POLARITY & TEST DISTANCE: VERTICAL AT 3 M

NO.	FREQ. (MHz)	EMISSION LEVEL (dBuV/m)	LIMIT (dBuV/m)	MARGIN (dB)	ANTENNA HEIGHT (m)	TABLE ANGLE (Degree)	RAW VALUE (dBuV)	CORRECTION FACTOR (dB/m)
1	#5470.00	69.1 PK	74.0	-4.9	1.00 V	175	64.93	4.17
2	#5470.00	53.1 AV	54.0	-0.9	1.00 V	175	48.93	4.17
3	*5530.00	106.8 PK			1.00 V	175	102.54	4.26
4	*5530.00	95.2 AV			1.00 V	175	90.94	4.26
5	11060.00	60.7 PK	74.0	-13.3	1.03 V	30	50.57	10.13
6	11060.00	45.2 AV	54.0	-8.8	1.03 V	30	35.07	10.13
7	#16590.00	65.1 PK	74.0	-8.9	1.06 V	17	48.68	16.42
8	#16590.00	51.9 AV	54.0	-2.1	1.06 V	17	35.48	16.42

REMARKS:

1. Emission Level(dBuV/m) = Raw Value(dBuV) + Correction Factor(dB/m)
2. Correction Factor(dB/m) = Antenna Factor(dB/m) + Cable Factor(dB) – Pre-Amplifier Factor(dB)
3. The other emission levels were very low against the limit.
4. Margin value = Emission Level – Limit value
5. " * ": Fundamental frequency.
6. " # ": The radiated frequency is out of the restricted band.

4.3 TRANSMIT POWER MEASUREMENT

4.3.1 LIMITS OF TRANSMIT POWER MEASUREMENT

Frequency Band	Limit
5.15 – 5.25GHz	The lesser of 50mW (17dBm) or 4dBm + 10logB
5.25 – 5.35GHz	The lesser of 250mW (24dBm) or 11dBm + 10logB
5.47 – 5.725GHz	The lesser of 250mW (24dBm) or 11dBm + 10logB
5.725 – 5.825GHz	The lesser of 1W (30dBm) or 17dBm + 10logB

NOTE: Where B is the 26dB emission bandwidth in MHz.

Per KDB 662911 D01 Multiple Transmitter Output Method of conducted output power measurement on IEEE 802.11 devices,

Array Gain = 0 dB (i.e., no array gain) for $NANT \leq 4$;

Array Gain = 0 dB (i.e., no array gain) for channel widths ≥ 40 MHz for any NANT;

Array Gain = $5 \log(NANT/NSS)$ dB or 3 dB, whichever is less for 20-MHz channel widths with $NANT \geq 5$.

For power measurements on all other devices: Array Gain = $10 \log(NANT/NSS)$ dB.



A D T

4.3.2 TEST INSTRUMENTS

FOR POWER OUTPUT MEASUREMENT

DESCRIPTION & MANUFACTURER	MODEL NO.	SERIAL NO.	CALIBRATED DATE	CALIBRATED UNTIL
Power meter Anritsu	ML2495A	1014008	Apr. 30, 2014	Apr. 29, 2015
Power sensor Anritsu	MA2411B	0917122	Apr. 30, 2014	Apr. 29, 2015

Note:

1. The calibration interval of the above test instruments is 12 months and the calibrations are traceable to NML/ROC and NIST/USA.
2. Tested date : Aug. 16, 2014

FOR 26dB OCCUPIED BANDWIDTH

DESCRIPTION & MANUFACTURER	MODEL NO.	SERIAL NO.	CALIBRATED DATE	CALIBRATED UNTIL
SPECTRUM ANALYZER R&S	FSV 40	100964	July 05, 2014	July 04, 2015

Note:

1. The calibration interval of the above test instruments is 12 months and the calibrations are traceable to NML/ROC and NIST/USA.
2. Tested date : Aug. 16, 2014

4.3.3 TEST PROCEDURE

FOR POWER OUTPUT MEASUREMENT

Method PM is used to perform output power measurement, trigger and gating function of wide band power meter is enabled to measure max output power of TX on burst. Duty factor is not added to measured value.

FOR 26dB OCCUPIED BANDWIDTH

1. Set RBW = approximately 1% of the emission bandwidth.
2. Set the VBW > RBW.
3. Detector = Peak.
4. Trace mode = max hold.
5. Measure the maximum width of the emission that is 26 dB down from the peak of the emission. Compare this with the RBW setting of the analyzer. Readjust RBW and repeat measurement as needed until the RBW/EBW ratio is approximately 1%.

4.3.4 DEVIATION FROM TEST STANDARD

No deviation

4.3.5 TEST SETUP

FOR POWER OUTPUT MEASUREMENT

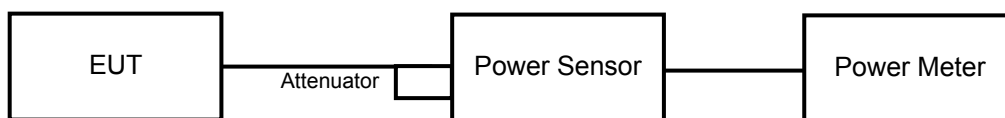

FOR 26dB OCCUPIED BANDWIDTH



4.3.6 EUT OPERATING CONDITIONS

The software provided by client to enable the EUT under transmission condition continuously at specific channel frequencies individually.



4.3.7 TEST RESULTS

802.11a

CHAN.	CHAN. FREQ. (MHz)	AVERAGE POWER (dBm)		TOTAL POWER (mW)	TOTAL POWER (dBm)	POWER LIMIT (dBm)	PASS / FAIL
		CHAIN 0	CHAIN 1				
52	5260	18.57	18.81	147.978	21.70	24	PASS
60	5300	18.97	18.67	152.507	21.83	24	PASS
64	5320	18.96	18.83	155.089	21.91	24	PASS
100	5500	18.97	18.76	154.048	21.88	24	PASS
116	5580	18.94	18.87	155.433	21.92	24	PASS
132	5660	18.49	18.82	146.84	21.67	24	PASS
140	5700	17.06	17.11	102.22	20.10	24	PASS

26dB OCCUPIED BANDWIDTH:

CHANNEL	CHANNEL FREQUENCY (MHz)	26dBc BANDWIDTH (MHz)	
		CHAIN 0	CHAIN 1
52	5260	22.28	22.56
60	5300	22.60	22.82
64	5320	22.62	22.15
100	5500	22.04	21.97
116	5580	22.09	22.85
132	5660	22.05	22.26
140	5700	21.03	22.31

Note: For output power limitation is determined based on 26dB emission bandwidth.

Power Limit = 11dBm + 10logB < UNII Band 2~3>			
Channel Number	Freq.(MHz)	Min. B(MHz)	Determined Conducted Limit (dBm)
52	5260	22.28	24.47 > 24
60	5300	22.60	24.54 > 24
64	5320	22.15	24.45 > 24
100	5500	21.97	24.41 > 24
116	5580	22.09	24.44 > 24
132	5660	22.05	24.43 > 24
140	5700	21.03	24.22 > 24



A D T

802.11ac (VHT20)

CHAN.	CHAN. FREQ. (MHz)	AVERAGE POWER (dBm)		TOTAL POWER (mW)	TOTAL POWER (dBm)	POWER LIMIT (dBm)	PASS / FAIL
		CHAIN 0	CHAIN 1				
52	5260	18.61	18.93	150.774	21.78	24	PASS
60	5300	18.29	18.91	145.257	21.62	24	PASS
64	5320	18.83	18.71	150.686	21.78	24	PASS
100	5500	18.72	18.97	153.359	21.86	24	PASS
116	5580	18.91	18.96	156.509	21.95	24	PASS
132	5660	18.62	18.91	150.582	21.78	24	PASS
140	5700	16.99	16.92	99.207	19.97	24	PASS

26dB OCCUPIED BANDWIDTH:

CHANNEL	CHANNEL FREQUENCY (MHz)	26dBc BANDWIDTH (MHz)	
		CHAIN 0	CHAIN 1
52	5260	23.66	22.85
60	5300	23.35	23.37
64	5320	23.43	23.19
100	5500	22.74	22.06
116	5580	23.14	22.65
132	5660	23.23	23.35
140	5700	22.90	22.75

Note: For output power limitation is determined based on 26dB emission bandwidth.

Power Limit = 11dBm + 10logB < UNII Band 2~3>			
Channel Number	Freq.(MHz)	Min. B(MHz)	Determined Conducted Limit (dBm)
52	5260	22.85	24.58 > 24
60	5300	23.35	24.68 > 24
64	5320	23.19	24.65 > 24
100	5500	22.06	24.43 > 24
116	5580	22.65	24.55 > 24
132	5660	23.23	24.66 > 24
140	5700	22.75	24.56 > 24



802.11ac (VHT40)

CHAN.	CHAN. FREQ. (MHz)	AVERAGE POWER (dBm)		TOTAL POWER (mW)	TOTAL POWER (dBm)	POWER LIMIT (dBm)	PASS / FAIL
		CHAIN 0	CHAIN 1				
54	5270	20.41	20.52	222.621	23.48	24	PASS
62	5310	18.15	18.01	128.554	21.09	24	PASS
102	5510	15.04	15.07	64.052	18.07	24	PASS
110	5550	20.44	20.81	231.166	23.64	24	PASS
134	5670	18.14	18.21	131.385	21.19	24	PASS

26dB OCCUPIED BANDWIDTH:

CHANNEL	CHANNEL FREQUENCY (MHz)	26dBc BANDWIDTH (MHz)	
		CHAIN 0	CHAIN 1
54	5270	48.53	46.80
62	5310	45.26	46.70
102	5510	45.35	44.06
110	5550	51.36	58.47
134	5670	46.33	46.33

Note: For output power limitation is determined based on 26dB emission bandwidth.

Power Limit = 11dBm + 10logB < UNII Band 2~3>			
Channel Number	Freq.(MHz)	Min. B(MHz)	Determined Conducted Limit (dBm)
54	5270	46.80	27.7 > 24
62	5310	45.26	27.55 > 24
102	5510	44.06	27.44 > 24
110	5550	51.36	28.1 > 24
134	5670	46.33	27.65 > 24



A D T

802.11ac (VHT80)

CHAN.	CHAN. FREQ. (MHz)	AVERAGE POWER (dBm)		TOTAL POWER (mW)	TOTAL POWER (dBm)	POWER LIMIT (dBm)	PASS / FAIL
		CHAIN 0	CHAIN 1				
58	5290	16.82	16.97	97.858	19.91	24	PASS
106	5530	13.21	13.32	42.419	16.28	24	PASS

26dB OCCUPIED BANDWIDTH:

CHANNEL	CHANNEL FREQUENCY (MHz)	26dBc BANDWIDTH (MHz)	
		CHAIN 0	CHAIN 1
58	5290	87.76	87.78
106	5530	85.31	86.93

Note: For output power limitation is determined based on 26dB emission bandwidth.

Power Limit = 11dBm + 10logB < UNII Band 2~3>			
Channel Number	Freq.(MHz)	Min. B(MHz)	Determined Conducted Limit (dBm)
58	5290	87.76	30.43 > 24
106	5530	85.31	30.3 > 24



A D T

4.4 PEAK POWER SPECTRAL DENSITY MEASUREMENT

4.4.1 LIMITS OF PEAK POWER SPECTRAL DENSITY MEASUREMENT

FREQUENCY BAND	LIMIT
5.15 ~ 5.25GHz	4dBm
5.25 ~ 5.35GHz	11dBm
5.47 – 5.725GHz	11dBm
5.725 ~ 5.825GHz	17dBm

4.4.2 TEST INSTRUMENTS

DESCRIPTION & MANUFACTURER	MODEL NO.	SERIAL NO.	CALIBRATED DATE	CALIBRATED UNTIL
SPECTRUM ANALYZER R&S	FSV 40	100964	July 05, 2014	July 04, 2015

Note:

1. The calibration interval of the above test instruments is 12 months and the calibrations are traceable to NML/ROC and NIST/USA.
2. Tested date : Aug. 16, 2014

4.4.3 TEST PROCEDURES

1. Set span to encompass the entire emission bandwidth (EBW) of the signal.
2. Set RBW = 1 MHz, Set VBW \geq 3 MHz, Detector = RMS
3. Sweep time = auto, trigger set to “free run”.
4. Trace average at least 100 traces in power averaging mode.
5. Record the max value and for duty cycle of test signal is $< 98\%$ add $10 \log (1/\text{duty cycle})$

4.4.4 DEVIATION FROM TEST STANDARD

No deviation

4.4.5 TEST SETUP

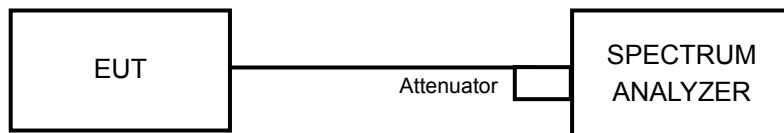

4.4.6 EUT OPERATING CONDITIONS

Same as 4.3.6



4.4.7 TEST RESULTS

802.11a

CHANNEL	CHANNEL FREQUENCY (MHz)	PSD (dBm)		TOTAL POWER DENSITY (dBm)	MAX. LIMIT (dBm)	PASS/FAIL
		CHAIN 0	CHAIN 1			
52	5260	5.01	4.99	8.01	9.37	PASS
60	5300	5.03	5.14	8.10	9.37	PASS
64	5320	4.89	5.10	8.01	9.37	PASS
100	5500	5.37	5.58	8.49	9.37	PASS
116	5580	4.30	5.87	8.17	9.37	PASS
132	5660	4.47	5.15	7.83	9.37	PASS
140	5700	3.34	3.79	6.58	9.37	PASS

NOTE: 1. Method a) of power density measurement of KDB 662911 is using for calculating total power density. Total power density is summing entire spectra across corresponding frequency bins on the various outputs by computer.

2. Directional gain = $10 \log[(10^{G1/20} + 10^{G2/20})^2 / 2]$ = 7.63dBi > 6dBi , so the power density limit shall be reduced to $11-(7.63-6) = 9.37\text{dBm}$.

802.11ac (VHT20)

CHANNEL	CHANNEL FREQUENCY (MHz)	PSD (dBm)		TOTAL POWER DENSITY (dBm)	MAX. LIMIT (dBm)	PASS/FAIL
		CHAIN 0	CHAIN 1			
52	5260	4.59	3.60	7.13	9.37	PASS
60	5300	4.53	4.79	7.67	9.37	PASS
64	5320	3.78	4.67	7.26	9.37	PASS
100	5500	5.18	4.95	8.08	9.37	PASS
116	5580	5.22	5.48	8.36	9.37	PASS
132	5660	4.22	4.94	7.61	9.37	PASS
140	5700	2.88	3.40	6.16	9.37	PASS

NOTE: 1. Method a) of power density measurement of KDB 662911 is using for calculating total power density. Total power density is summing entire spectra across corresponding frequency bins on the various outputs by computer.

2. Directional gain = $10 \log[(10^{G1/20} + 10^{G2/20})^2 / 2]$ = 7.63dBi > 6dBi , so the power density limit shall be reduced to $11-(7.63-6) = 9.37\text{dBm}$.

802.11ac (VHT40)

CHANNEL	CHANNEL FREQUENCY (MHz)	PSD W/O DUTY FACTOR (dBm)		DUTY FACTOR (dB)	TOTAL PSD WITH DUTY FACTOR (dBm)	MAX. LIMIT (dBm)	PASS / FAIL
		CHAIN 0	CHAIN 1				
54	5270	2.67	2.28	0.13	5.62	9.37	PASS
62	5310	0.85	-0.08	0.13	3.55	9.37	PASS
102	5510	-1.76	-1.37	0.13	1.58	9.37	PASS
110	5550	4.38	4.50	0.13	7.58	9.37	PASS
134	5670	0.72	1.08	0.13	4.04	9.37	PASS

- NOTE:** 1. Method a) of power density measurement of KDB 662911 is using for calculating total power density. Total power density is summing entire spectra across corresponding frequency bins on the various outputs by computer.
2. Directional gain = $10 \log[(10^{G1/20} + 10^{G2/20})^2 / 2]$ = 7.63dBi > 6dBi , so the power density limit shall be reduced to $11-(7.63-6) = 9.37$ dBm.
3. Refer to section 3.4 for duty cycle spectrum plot.

802.11ac (VHT80)

CHANNEL	CHANNEL FREQUENCY (MHz)	PSD W/O DUTY FACTOR (dBm)		DUTY FACTOR (dB)	TOTAL PSD WITH DUTY FACTOR (dBm)	MAX. LIMIT (dBm)	PASS / FAIL
		CHAIN 0	CHAIN 1				
58	5290	-3.54	-4.48	0.24	-0.73	9.37	PASS
106	5530	-6.94	-6.77	0.24	-3.60	9.37	PASS

- NOTE:** 1. Method a) of power density measurement of KDB 662911 is using for calculating total power density. Total power density is summing entire spectra across corresponding frequency bins on the various outputs by computer.
2. Directional gain = $10 \log[(10^{G1/20} + 10^{G2/20})^2 / 2]$ = 7.63dBi > 6dBi , so the power density limit shall be reduced to $11-(7.63-6) = 9.37$ dBm.
3. Refer to section 3.4 for duty cycle spectrum plot.

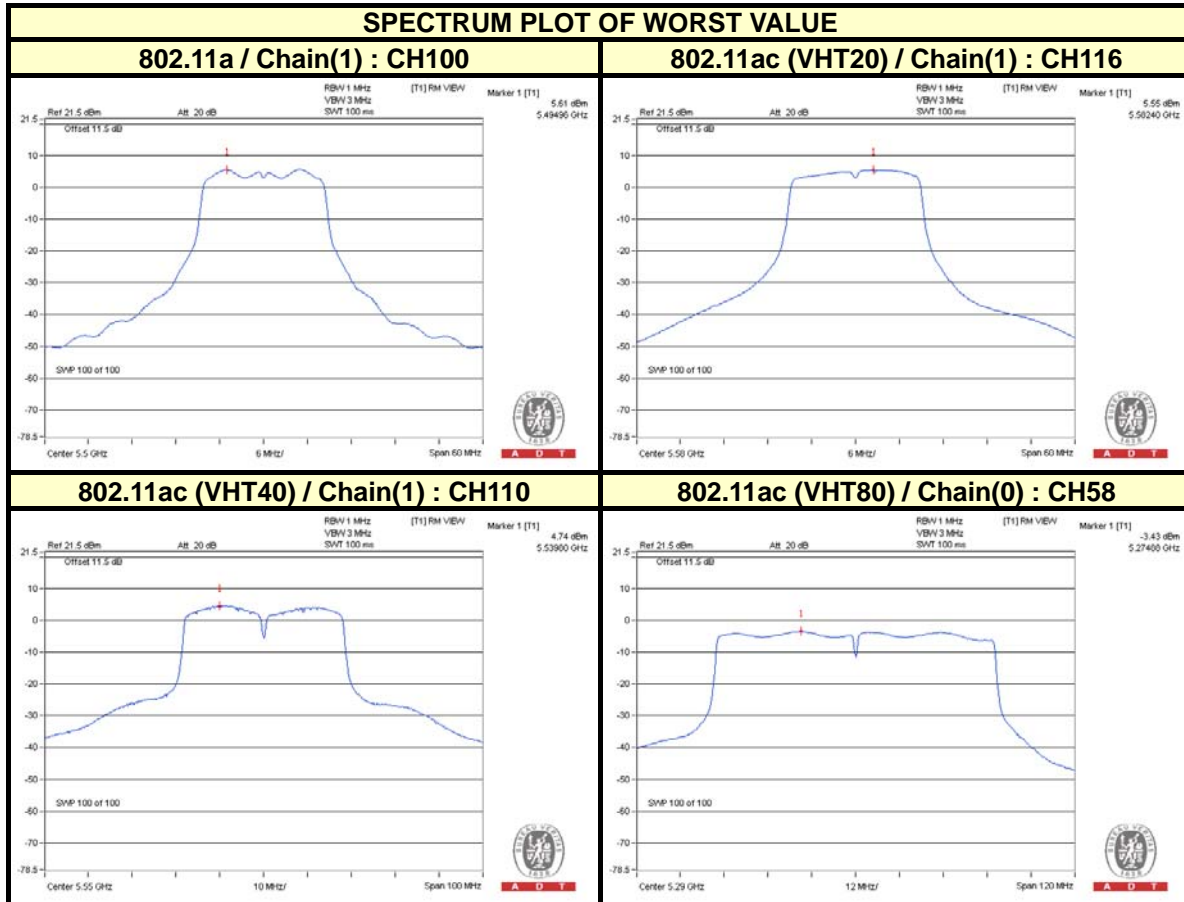



A D T

4.5 PEAK POWER EXCURSION MEASUREMENT

4.5.1 LIMITS OF PEAK POWER EXCURSION MEASUREMENT

Shall not exceed 13 dB

4.5.2 TEST INSTRUMENTS

DESCRIPTION & MANUFACTURER	MODEL NO.	SERIAL NO.	CALIBRATED DATE	CALIBRATED UNTIL
SPECTRUM ANALYZER R&S	FSV 40	100964	July 05, 2014	July 04, 2015

Note:

1. The calibration interval of the above test instruments is 12 months and the calibrations are traceable to NML/ROC and NIST/USA.
2. Tested date : Aug. 16, 2014

4.5.3 TEST PROCEDURE

1. Set RBW = 1 MHz, VBW \geq 3 MHz, Detector = peak.
2. Trace mode = max-hold. Allow the sweeps to continue until the trace stabilizes.
3. Use the peak search function to find the peak of the spectrum.
4. Measure the PPSD.
5. Compute the ratio of the maximum of the peak-max-hold spectrum to the PPSD.

4.5.4 DEVIATION FROM TEST STANDARD

No deviation

4.5.5 TEST SETUP

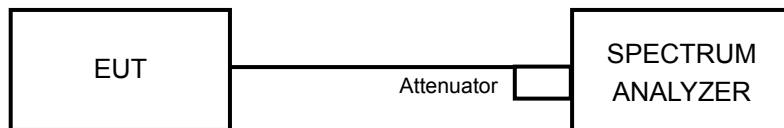



A D T

4.5.6 EUT OPERATING CONDITIONS

The software provided by client to enable the EUT under transmission condition continuously at specific channel frequencies individually.



4.5.7 TEST RESULTS

Without duty factor:

MODULATION MODE	MODULATION TYPE	CHANNEL FREQUENCY (MHz)	PEAK VALUE (dBm)	PPSD (dBm)	PEAK EXCURSION (dB)	LIMIT (dB)	PASS/ FAIL
802.11a	BPSK	5700	13.23	3.34	9.89	13	PASS
802.11ac (VHT20)	BPSK	5700	11.89	2.88	9.01	13	PASS

With duty factor:

MODULATION MODE	MODULATION TYPE	CHAN. FREQ. (MHz)	PEAK VALUE (dBm)	PPSD WITHOUT DUTY FACTOR (dBm)	PPSD WITH DUTY FACTOR (dBm)	PEAK EXCURSION (dB)	LIMIT (dB)	PASS /FAIL
802.11a	QPSK	5700	13.05	3.34	3.45	9.60	13	PASS
	16QAM		14.08	3.06	3.27	10.81	13	PASS
	64QAM		12.96	3.07	3.45	9.51	13	PASS
802.11ac (VHT20)	QPSK	5700	12.39	2.75	2.86	9.53	13	PASS
	16QAM		12.82	2.63	2.84	9.98	13	PASS
	64QAM		13.28	2.50	2.89	10.39	13	PASS
	256QAM		13.49	2.40	3.02	10.47	13	PASS
802.11ac (VHT40)	BPSK	5670	10.08	0.91	1.04	9.04	13	PASS
	QPSK		10.78	0.55	0.76	10.02	13	PASS
	16QAM		11.81	0.92	1.34	10.47	13	PASS
	64QAM		11.64	0.82	1.56	10.08	13	PASS
	256QAM		11.43	0.61	1.58	9.85	13	PASS
802.11ac (VHT80)	BPSK	5530	2.93	-6.59	-6.35	9.28	13	PASS
	QPSK		4.47	-6.74	-6.32	10.79	13	PASS
	16QAM		5.34	-6.73	-5.97	11.31	13	PASS
	64QAM		5.00	-6.68	-5.42	10.42	13	PASS
	256QAM		4.29	-7.05	-5.39	9.68	13	PASS

NOTE: 1. Refer to section 3.4 for duty cycle spectrum plot.



A D T

SPECTRUM PLOT OF WORST VALUE

802.11a / 16QAM

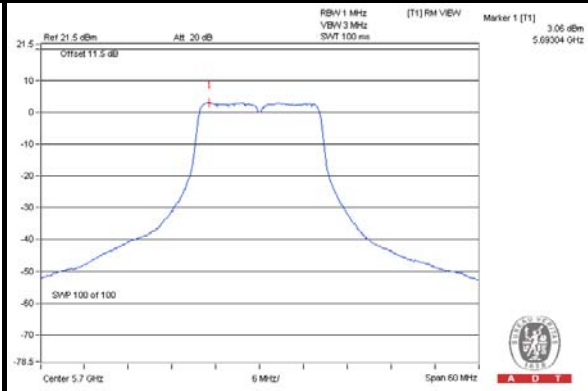
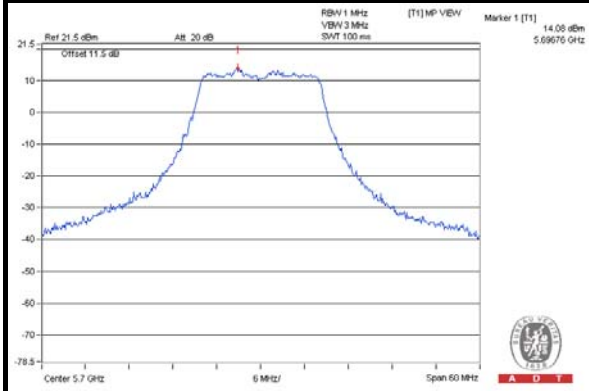

802.11ac (VHT20) / 256QAM

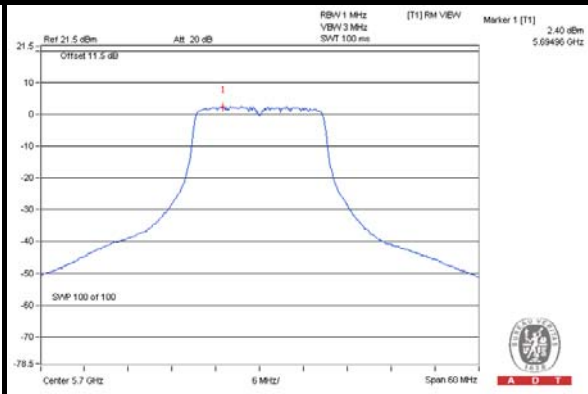
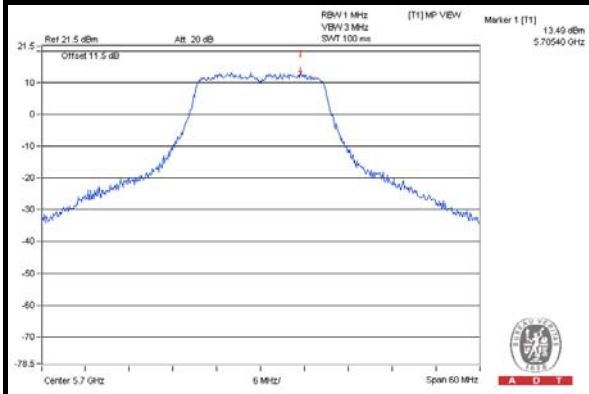

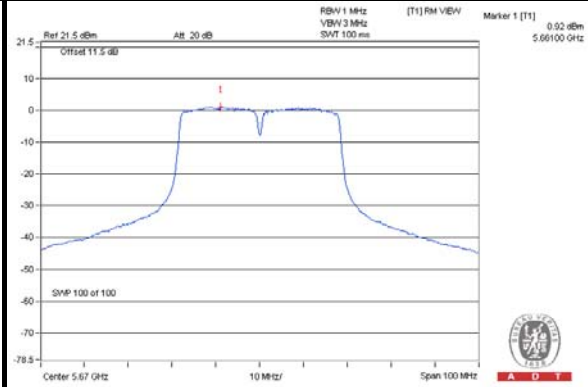
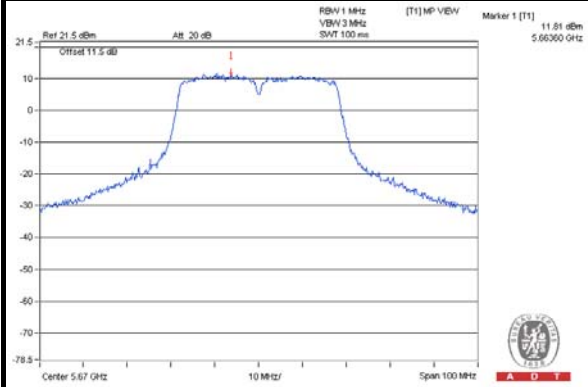
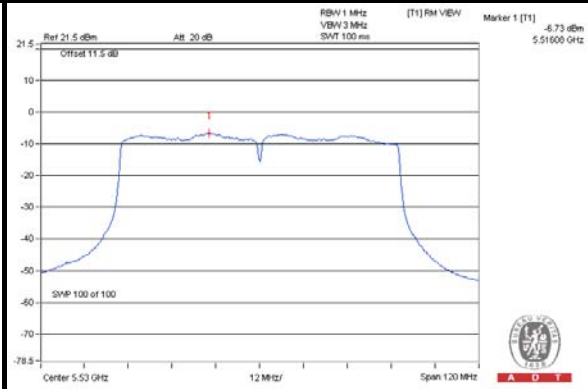
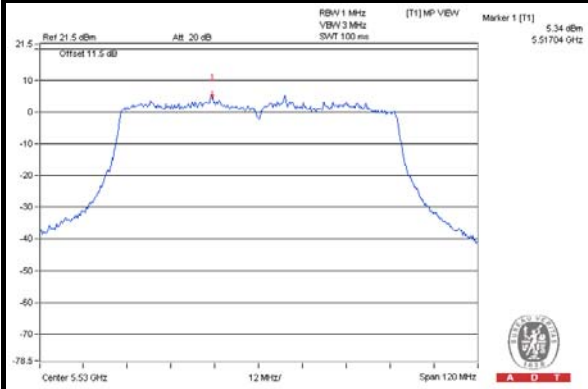
802.11ac (VHT40) / 16QAM**802.11ac (VHT80) / 16QAM**



A D T

4.6 FREQUENCY STABILITY

4.6.1 LIMITS OF FREQUENCY STABILITY MEASUREMENT

The frequency of the carrier signal shall be maintained within band of operation

4.6.2 TEST INSTRUMENTS

DESCRIPTION & MANUFACTURER	MODEL NO.	SERIAL NO.	CALIBRATED DATE	CALIBRATED UNTIL
SPECTRUM ANALYZER R&S	FSV 40	100964	July 05, 2014	July 04, 2015
Temperature Humidity Chamber GIANTFORCE &	GTH-150-40-SP -AR	MAA0812-008	Jan. 13, 2014	Jan. 12, 2015

Note:

1. The calibration interval of the above test instruments is 12 months and the calibrations are traceable to NML/ROC and NIST/USA.
2. Tested date : Aug. 16, 2014

4.6.3 TEST PROCEDURE

1. The EUT was placed inside the environmental test chamber and powered by nominal AC voltage.
2. Turn the EUT on and couple its output to a spectrum analyzer.
3. Turn the EUT off and set the chamber to the highest temperature specified.
4. Allow sufficient time (approximately 30 min) for the temperature of the chamber to stabilize, turn the EUT on and measure the operating frequency after 2, 5, and 10 minutes.
5. Repeat step 2 and 3 with the temperature chamber set to the lowest temperature.
6. The test chamber was allowed to stabilize at +20 degree C for a minimum of 30 minutes. The supply voltage was then adjusted on the EUT from 85% to 115% and the frequency record.

4.6.4 DEVIATION FROM TEST STANDARD

No deviation

4.6.5 TEST SETUP

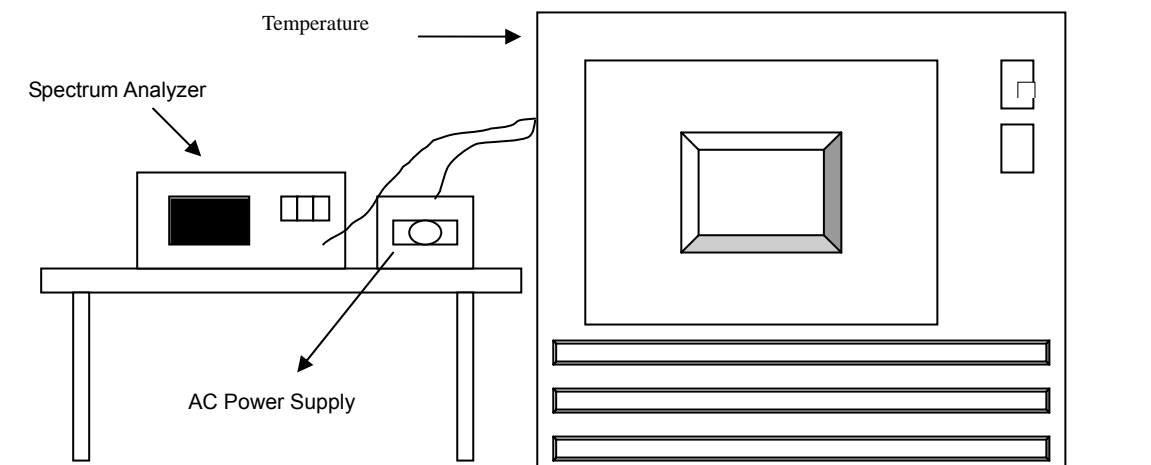

4.6.6 EUT OPERATING CONDITION

Set the EUT transmit at un-modulation mode to test frequency stability.



A D T

4.6.7 TEST RESULTS

FREQUENCY STABILITY VERSUS TEMP.									
OPERATING FREQUENCY: 5320MHz									
TEMP. (°C)	POWER SUPPLY (Vac)	0 MINUTE		2 MINUTE		5 MINUTE		10 MINUTE	
		Measured Frequency	Frequency Drift	Measured Frequency	Frequency Drift	Measured Frequency	Frequency Drift	Measured Frequency	Frequency Drift
		(MHz)	%	(MHz)	%	(MHz)	%	(MHz)	%
50	120	5320.0214	0.00040	5320.0194	0.00036	5320.0185	0.00035	5320.0187	0.00035
40	120	5319.9948	-0.00010	5319.9911	-0.00017	5319.9952	-0.00009	5319.993	-0.00013
30	120	5319.9756	-0.00046	5319.9775	-0.00042	5319.9781	-0.00041	5319.9748	-0.00047
20	120	5319.9792	-0.00039	5319.9791	-0.00039	5319.9838	-0.00030	5319.9802	-0.00037
10	120	5319.9758	-0.00045	5319.9793	-0.00039	5319.9754	-0.00046	5319.9758	-0.00045
0	120	5319.9951	-0.00009	5319.9973	-0.00005	5319.9964	-0.00007	5319.9975	-0.00005
-10	120	5319.9778	-0.00042	5319.9778	-0.00042	5319.9755	-0.00046	5319.9798	-0.00038
-20	120	5319.9933	-0.00013	5319.9934	-0.00012	5319.9956	-0.00008	5319.994	-0.00011
-30	120	5319.9968	-0.00006	5319.9958	-0.00008	5319.9946	-0.00010	5319.998	-0.00004

FREQUENCY STABILITY VERSUS VOLTAGE									
OPERATING FREQUENCY: 5320MHz									
TEMP. (°C)	POWER SUPPLY (Vac)	0 MINUTE		2 MINUTE		5 MINUTE		10 MINUTE	
		Measured Frequency	Frequency Drift	Measured Frequency	Frequency Drift	Measured Frequency	Frequency Drift	Measured Frequency	Frequency Drift
		(MHz)	%	(MHz)	%	(MHz)	%	(MHz)	%
20	138	5319.9784	-0.00041	5319.9781	-0.00041	5319.9832	-0.00032	5319.981	-0.00036
	120	5319.9792	-0.00039	5319.9791	-0.00039	5319.9838	-0.00030	5319.9802	-0.00037
	102	5319.9792	-0.00039	5319.979	-0.00039	5319.9844	-0.00029	5319.9793	-0.00039



A D T

5. PHOTOGRAPHS OF THE TEST CONFIGURATION

Please refer to the attached file (Test Setup Photo).





6. INFORMATION ON THE TESTING LABORATORIES

We, Bureau Veritas Consumer Products Services (H.K.) Ltd., Taoyuan Branch, were founded in 1988 to provide our best service in EMC, Radio, Telecom and Safety consultation. Our laboratories are accredited and approved according to ISO/IEC 17025.

If you have any comments, please feel free to contact us at the following:

Linko EMC/RF Lab:

Tel: 886-2-26052180

Fax: 886-2-26052943

Hsin Chu EMC/RF Lab:

Tel: 886-3-5935343

Fax: 886-3-5935342

Hwa Ya EMC/RF/Safety/Telecom Lab:

Tel: 886-3-3183232

Fax: 886-3-3270892

Email: service.adt@tw.bureauveritas.com

Web Site: www.bureauveritas-adt.com

The address and road map of all our labs can be found in our web site also.



A D T

7. APPENDIX A - MODIFICATIONS RECORDERS FOR ENGINEERING CHANGES TO THE EUT BY THE LAB

No modifications were made to the EUT by the lab during the test.

--- END ---