



# FCC TEST REPORT (15.407)

**REPORT NO.:** RF140717E01-1

**MODEL NO.:** C-65

**FCC ID:** TOR-C-65

**RECEIVED:** July 17, 2014

**TESTED:** July 28 to Aug. 08, 2014

**ISSUED:** Aug. 25, 2014

**APPLICANT:** AirTight Networks Inc.

**ADDRESS:** 339 N Bernardo Ave, Mountain View, CA 94043,  
United States

**ISSUED BY:** Bureau Veritas Consumer Products Services (H.K.) Ltd.,  
Taoyuan Branch Hsin Chu Laboratory

**LAB ADDRESS :** No. 81-1, Lu Liao Keng, 9th Ling, Wu Lung Tsuen,  
Chiung Lin Hsiang, Hsin Chu Hsien 307, Taiwan, R.O.C.

**TEST LOCATION (1):** No. 81-1, Lu Liao Keng, 9th Ling, Wu Lung Tsuen,  
Chiung Lin Hsiang, Hsin Chu Hsien 307, Taiwan, R.O.C.

**TEST LOCATION (2):** No. 49, Ln. 206, Wende Rd., Shangshan Tsuen, Chiung  
Lin Hsiang, Hsin Chu Hsien 307, Taiwan, R.O.C.

This report should not be used by the client to claim product certification, approval, or endorsement by TAF or any government agencies.



This report is for your exclusive use. Any copying or replication of this report to or for any other person or entity, or use of our name or trademark, is permitted only with our prior written permission. This report sets forth our findings solely with respect to the test samples identified herein. The results set forth in this report are not indicative or representative of the quality or characteristics of the lot from which a test sample was taken or any similar or identical product unless specifically and expressly noted. Our report includes all of the tests requested by you and the results thereof based upon the information that you provided to us. You have 60 days from date of issuance of this report to notify us of any material error or omission caused by our negligence, provided, however, that such notice shall be in writing and shall specifically address the issue you wish to raise. A failure to raise such issue within the prescribed time shall constitute your unqualified acceptance of the completeness of this report, the tests conducted and the correctness of the report contents. Unless specific mention, the uncertainty of measurement has been explicitly taken into account to declare the compliance or non-compliance to the specification



A D T

## Table of Contents

RELEASE CONTROL RECORD .....	4
1. CERTIFICATION .....	5
2. SUMMARY OF TEST RESULTS .....	6
2.1 MEASUREMENT UNCERTAINTY .....	7
3. GENERAL INFORMATION .....	8
3.1 GENERAL DESCRIPTION OF EUT .....	8
3.2 DESCRIPTION OF TEST MODES .....	11
3.2.1 TEST MODE APPLICABILITY AND TESTED CHANNEL DETAIL .....	12
3.3 GENERAL DESCRIPTION OF APPLIED STANDARDS .....	14
3.4 DUTY CYCLE OF TEST SIGNAL .....	15
3.5 DESCRIPTION OF SUPPORT UNITS.....	19
3.6 CONFIGURATION OF SYSTEM UNDER TEST .....	20
4. TEST TYPES AND RESULTS .....	22
4.1 CONDUCTED EMISSION MEASUREMENT .....	22
4.1.1 LIMITS OF CONDUCTED EMISSION MEASUREMENT .....	22
4.1.2 TEST INSTRUMENTS.....	22
4.1.3 TEST PROCEDURES .....	23
4.1.4 DEVIATION FROM TEST STANDARD .....	23
4.1.5 TEST SETUP .....	23
4.1.6 EUT OPERATING CONDITIONS .....	24
4.1.7 TEST RESULTS (MODE 1) .....	25
4.1.8 TEST RESULTS (MODE 2) .....	27
4.2 RADIATED EMISSION AND BANDEDGE MEASUREMENT .....	29
4.2.1 LIMITS OF RADIATED EMISSION AND BANDEDGE MEASUREMENT.....	29
4.2.2 LIMITS OF UNWANTED EMISSION OUT OF THE RESTRICTED BANDS.....	29
4.2.3 TEST INSTRUMENTS.....	30
4.2.4 TEST PROCEDURES .....	31
4.2.5 DEVIATION FROM TEST STANDARD .....	31
4.2.6 TEST SETUP .....	32
4.2.7 EUT OPERATING CONDITION.....	32
4.2.8 TEST RESULTS .....	33
4.3 TRANSMIT POWER MEASUREMENT .....	43
4.3.1 LIMITS OF TRANSMIT POWER MEASUREMENT .....	43
4.3.2 TEST INSTRUMENTS.....	44
4.3.3 TEST PROCEDURE.....	44
4.3.4 DEVIATION FROM TEST STANDARD .....	45
4.3.5 TEST SETUP .....	45
4.3.6 EUT OPERATING CONDITIONS .....	45



A D T

4.3.7	TEST RESULTS .....	46
4.4	PEAK POWER SPECTRAL DENSITY MEASUREMENT .....	50
4.4.1	LIMITS OF PEAK POWER SPECTRAL DENSITY MEASUREMENT .....	50
4.4.2	TEST INSTRUMENTS.....	50
4.4.3	TEST PROCEDURES .....	50
4.4.4	DEVIATION FROM TEST STANDARD .....	50
4.4.5	TEST SETUP .....	51
4.4.6	EUT OPERATING CONDITIONS .....	51
4.4.7	TEST RESULTS .....	52
4.5	PEAK POWER EXCURSION MEASUREMENT .....	55
4.5.1	LIMITS OF PEAK POWER EXCURSION MEASUREMENT .....	55
4.5.2	TEST INSTRUMENTS.....	55
4.5.3	TEST PROCEDURE.....	55
4.5.4	DEVIATION FROM TEST STANDARD .....	55
4.5.5	TEST SETUP .....	55
4.5.6	EUT OPERATING CONDITIONS .....	56
4.5.7	TEST RESULTS .....	57
4.6	FREQUENCY STABILITY.....	60
4.6.1	LIMITS OF FREQUENCY STABILITY MEASUREMENT .....	60
4.6.2	TEST INSTRUMENTS.....	60
4.6.3	TEST PROCEDURE.....	60
4.6.4	DEVIATION FROM TEST STANDARD .....	61
4.6.5	TEST SETUP .....	61
4.6.6	EUT OPERATING CONDITION.....	61
4.6.7	TEST RESULTS .....	62
5.	PHOTOGRAPHS OF THE TEST CONFIGURATION.....	63
6.	INFORMATION ON THE TESTING LABORATORIES .....	64
7.	APPENDIX A - MODIFICATIONS RECORDERS FOR ENGINEERING CHANGES TO THE EUT BY THE LAB.....	65



A D T

## RELEASE CONTROL RECORD

ISSUE NO.	REASON FOR CHANGE	DATE ISSUED
RF140717E01-1	Original release	Aug. 25, 2014



## 2. SUMMARY OF TEST RESULTS

The EUT has been tested according to the following specifications:

APPLIED STANDARD: FCC PART 15, SUBPART E (SECTION 15.407)			
STANDARD SECTION	TEST TYPE	RESULT	REMARK
15.407(b)(6)	AC Power Conducted Emission	PASS	Meet the requirement of limit. Minimum passing margin is -10.21dB at 11.47266MHz
15.407(b/1/2/3) (b)(6)	Spurious Emissions	PASS	Meet the requirement of limit. Minimum passing margin is -0.7dB at 5150.00MHz
15.407(a/1/2)	Transmit Power	PASS	Meet the requirement of limit.
15.407(a)(6)	Peak Power Excursion	PASS	Meet the requirement of limit.
15.407(a/1/2)	Peak Power Spectral Density	PASS	Meet the requirement of limit.
15.407(g)	Frequency Stability	PASS	Meet the requirement of limit.
15.203	Antenna Requirement	PASS	Antenna connector is IPEX not a standard connector.

**NOTE: 1.** The EUT was operating in 2400 ~ 2483.5MHz, 5.15~5.25GHz, and 5.725~5.850GHz frequencies band. This report was recorded the RF parameters including 5.15~5.25GHz. For the 2400 ~ 2483.5MHz and 5.725~5.850GHz RF parameters was recorded in another test report.



A D T

## 2.1 MEASUREMENT UNCERTAINTY

Where relevant, the following measurement uncertainty levels have been estimated for tests performed on the EUT as specified in CISPR 16-4-2:

This uncertainty represents an expanded uncertainty expressed at approximately the 95% confidence level using a coverage factor of  $k=2$ .

Measurement	Value
Conducted emissions	2.86 dB
Radiated emissions (30MHz-1GHz)	5.37 dB
Radiated emissions (1GHz -6GHz)	3.65 dB
Radiated emissions (6GHz -18GHz)	3.88 dB
Radiated emissions (18GHz -40GHz)	4.11 dB



### 3. GENERAL INFORMATION

#### 3.1 GENERAL DESCRIPTION OF EUT

<b>PRODUCT</b>	Access Point / Sensor
<b>MODEL NO.</b>	C-65
<b>POWER SUPPLY</b>	DC12V from power adapter or DC 48V from PoE
<b>MODULATION TYPE</b>	CCK, DQPSK, DBPSK for DSSS 64QAM, 16QAM, QPSK, BPSK for OFDM 256QAM for OFDM in 11ac mode only
<b>MODULATION TECHNOLOGY</b>	DSSS,OFDM
<b>TRANSFER RATE</b>	802.11b: up to 11Mbps 802.11a / g: up to 54Mbps 802.11n: up to 300Mbps 802.11ac: up to 866.7Mbps
<b>OPERATING FREQUENCY</b>	<b>For 15.407</b> <b>5GHz:</b> 5.18 ~ 5.24GHz
	<b>For 15.247</b> <b>2.4GHz:</b> 2.412 ~ 2.462GHz <b>5GHz:</b> 5.745 ~ 5.825GHz
<b>NUMBER OF CHANNEL</b>	<b>For 15.407</b> 4 for 802.11a, 802.11n (HT20), 802.11ac (VHT20) 2 for 802.11n (HT40), 802.11ac (VHT40) 1 for 802.11ac (VHT80)
	<b>For 15.247 (2.4GHz)</b> 11 for 802.11b, 802.11g, 802.11n (HT20) 7 for 802.11n (HT40) <b>For 15.247 (5GHz)</b> 5 for 802.11a, 802.11n (HT20), 802.11ac (VHT20) 2 for 802.11n (HT40), 802.11ac (VHT40) 1 for 802.11ac (VHT80)





A D T

<b>MAXIMUM OUTPUT POWER</b>	<b>For 15.407</b> 802.11a: .31.863mW 802.11ac (VHT20): 30.61mW 802.11ac (VHT40): 46.944mW 802.11ac (VHT80): 44.373mW
	<b>For 15.247 (2.4GHz)</b> 802.11b: 292.634mW 802.11g: 347.353mW 802.11n (HT20): 227.854mW 802.11n (HT40): 109.794mW
	<b>For 15.247 (5GHz)</b> 802.11a: 397.228mW 802.11ac (VHT20): 396.343mW 802.11ac (VHT40): 532.978mW 802.11ac (VHT80): 97.373mW
<b>ANTENNA TYPE</b>	Please see NOTE
<b>DATA CABLE</b>	NA
<b>I/O PORTS</b>	Refer to user's manual
<b>ASSOCIATED DEVICES</b>	Adapter x 1

**Note:**

- 2.4GHz and 5GHz technology can transmit at same time.
- The antennas provided to the EUT, please refer to the following table:

For 2.4G WLAN used								
Ant. No.	Transmitter Circuit	Brand	Part No.	Antenna Gain(dBi) <including cable loss>	Frequency range (MHz ~ MHz)	Antenna Type	Connector Type	Cable Length (mm)
1	Chain (0)	LYNwave	ALA140-05102A-000000	4.42	2412~2483	PCB-Dipole	IPEX	85
2	Chain (1)		ALA140-05102A-000001	4.39				170
For 5G WLAN used								
Ant. No.	Transmitter Circuit	Brand	Part No.	Antenna Gain(dBi) <including cable loss>	Frequency range (MHz ~ MHz)	Antenna Type	Connector Type	Cable Length (mm)
1	Chain (0)	LYNwave	ALA140-091025-000000	4.39	5150~5825	PCB-Dipole	IPEX	70
2	Chain (1)		ALA140-091025-000001	4.84				160



A D T

3. The EUT must be supplied with a power adapter as following table:

No	Brand	Model No.	Spec.
1	LEI	MU18-R120150-A1	Input: 100-240V, 0.6A, 50/60Hz Output: 12V, 1.5A DC power cable: 1.53m, unshielded

4. The EUT incorporates a MIMO function without beamforming.

MODULATION MODE	DATA RATE (MCS)	TX & RX CONFIGURATION	
802.11a	6 ~ 54Mbps	2TX (CDD)	2RX
802.11b	1 ~ 11Mbps	2TX (CDD)	2RX
802.11g	6 ~ 54Mbps	2TX (CDD)	2RX
802.11n (HT20) & 802.11n (HT40)	MCS 0~7	2TX (CDD)	2RX
	MCS 8~15	2TX	2RX
802.11ac (VHT20)	MCS0~8 (256QAM) Nss= 1	2TX (CDD)	2RX
	MCS0~8 (256QAM) Nss= 2	2TX	2RX
802.11ac (VHT40) & 802.11ac (VHT80)	MCS0~9 (256QAM) Nss= 1	2TX (CDD)	2RX
	MCS0~9 (256QAM) Nss= 2	2TX	2RX

**Note:** The modulation and bandwidth are similar for 802.11n mode for 20MHz (40MHz) and 802.11ac mode for 20MHz (40MHz), therefore investigated worst case to representative mode in test report. (Final test mode refer section 3.2.1)

5. The above EUT information was declared by manufacturer and for more detailed features description, please refer to the manufacturer's specifications or user's manual.



A D T

### 3.2 DESCRIPTION OF TEST MODES

4 channels are provided for 802.11a, 802.11n (HT20), 802.11ac (VHT20):

CHANNEL	FREQUENCY	CHANNEL	FREQUENCY
36	5180 MHz	44	5220 MHz
40	5200 MHz	48	5240 MHz

2 channels are provided for 802.11n (HT40), 802.11ac (VHT40):

CHANNEL	FREQUENCY
38	5190 MHz
46	5230 MHz

1 channel is provided for 802.11ac (VHT80):

CHANNEL	FREQUENCY
42	5210 MHz



### 3.2.1 TEST MODE APPLICABILITY AND TESTED CHANNEL DETAIL

EUT CONFIGURE MODE	APPLICABLE TO				DESCRIPTION
	PLC	RE < 1G	RE ≥ 1G	APCM	
1	√	√	√	√	Adapter Mode
2	√	-	-	-	PoE Mode

Where **PLC**: Power Line Conducted Emission      **RE < 1G**: Radiated Emission below 1GHz

**RE ≥ 1G**: Radiated Emission above 1GHz      **APCM**: Antenna Port Conducted Measurement

**NOTE**: The EUT had been pre-tested on the positioned of each 2 axis. The worst case was found when positioned on **X-plane** (for below 1GHz) and **Y-plane** (for above 1GHz).

#### **POWER LINE CONDUCTED EMISSION TEST:**

- Pre-Scan has been conducted to determine the worst-case mode from all possible combinations between available modulations, data rates and antenna ports (if EUT with antenna diversity architecture).
- Following channel(s) was (were) selected for the final test as listed below.

MODE	AVAILABLE CHANNEL	TESTED CHANNEL	MODULATION TECHNOLOGY	MODULATION TYPE	DATA RATE (Mbps)
802.11ac (VHT40)	38 to 46	46	OFDM	BPSK	13.5

#### **RADIATED EMISSION TEST (BELOW 1 GHz):**

- Pre-Scan has been conducted to determine the worst-case mode from all possible combinations between available modulations, data rates and antenna ports (if EUT with antenna diversity architecture).
- Following channel(s) was (were) selected for the final test as listed below.

MODE	AVAILABLE CHANNEL	TESTED CHANNEL	MODULATION TECHNOLOGY	MODULATION TYPE	DATA RATE (Mbps)
802.11ac (VHT40)	38 to 46	46	OFDM	BPSK	13.5



A D T

**RADIATED EMISSION TEST (ABOVE 1 GHz):**

- Pre-Scan has been conducted to determine the worst-case mode from all possible combinations between available modulations, data rates and antenna ports (if EUT with antenna diversity architecture).
- Following channel(s) was (were) selected for the final test as listed below.

MODE	AVAILABLE CHANNEL	TESTED CHANNEL	MODULATION TECHNOLOGY	MODULATI ON TYPE	DATA RATE (Mbps)
802.11a	36 to 48	36, 40, 48	OFDM	BPSK	6
802.11ac (VHT20)	36 to 48	36, 40, 48	OFDM	BPSK	6.5
802.11ac (VHT40)	38 to 46	38, 46	OFDM	BPSK	13.5
802.11ac (VHT80)	42	42	OFDM	BPSK	29.3

**ANTENNA PORT CONDUCTED MEASUREMENT:**

- Pre-Scan has been conducted to determine the worst-case mode from all possible combinations between available modulations, data rates and antenna ports (if EUT with antenna diversity architecture).
- Following channel(s) was (were) selected for the final test as listed below.

MODE	AVAILABLE CHANNEL	TESTED CHANNEL	MODULATION TECHNOLOGY	MODULATI ON TYPE	DATA RATE (Mbps)
802.11a	36 to 48	36, 40, 48	OFDM	BPSK	6
802.11ac (VHT20)	36 to 48	36, 40, 48	OFDM	BPSK	6.5
802.11ac (VHT40)	38 to 46	38, 46	OFDM	BPSK	13.5
802.11ac (VHT80)	42	42	OFDM	BPSK	29.3

**TEST CONDITION:**

APPLICABLE TO	ENVIRONMENTAL CONDITIONS	INPUT POWER	TESTED BY
PLC	30deg. C, 70%RH	120Vac, 60Hz	Mike Hsieh
RE<1G	25deg. C, 65%RH	120Vac, 60Hz	Andy Ho
RE <sup>3</sup> 1G	23deg. C, 75%RH	120Vac, 60Hz	Robert Cheng
APCM	25deg. C, 60%RH	120Vac, 60Hz	James Chan



### **3.3 GENERAL DESCRIPTION OF APPLIED STANDARDS**

The EUT is a RF product. According to the specifications of the manufacturer, it must comply with the requirements of the following standards:

#### **FCC Part 15, Subpart E (15.407)**

**789033 D01 General UNII Test Procedures Old Rules v01r04**

**662911 D01 Multiple Transmitter Output v02r01**

ANSI C63.10-2009

All test items have been performed and recorded as per the above standards.

**Note:** The EUT has been verified to comply with the requirements of FCC Part 15, Subpart B, Class B (DoC). The test report has been issued separately.

### 3.4 DUTY CYCLE OF TEST SIGNAL

If duty cycle of test signal is  $\geq 98\%$ , duty factor is not required.

If duty cycle of test signal is  $< 98\%$ , duty factor shall be considered.

#### 802.11a

**BPSK:** Duty cycle = 5.357 ms/5.422 ms = 0.988

**QPSK:** Duty cycle = 2.685 ms/2.752 ms = 0.976, Duty factor =  $10 * \log(1/0.976) = 0.11$

**16QAM:** Duty cycle = 1.347 ms/1.547 ms = 0.871, Duty factor =  $10 * \log(1/0.871) = 0.6$

**64QAM:** Duty cycle = 0.68 ms/0.742 ms = 0.916, Duty factor =  $10 * \log(1/0.916) = 0.38$

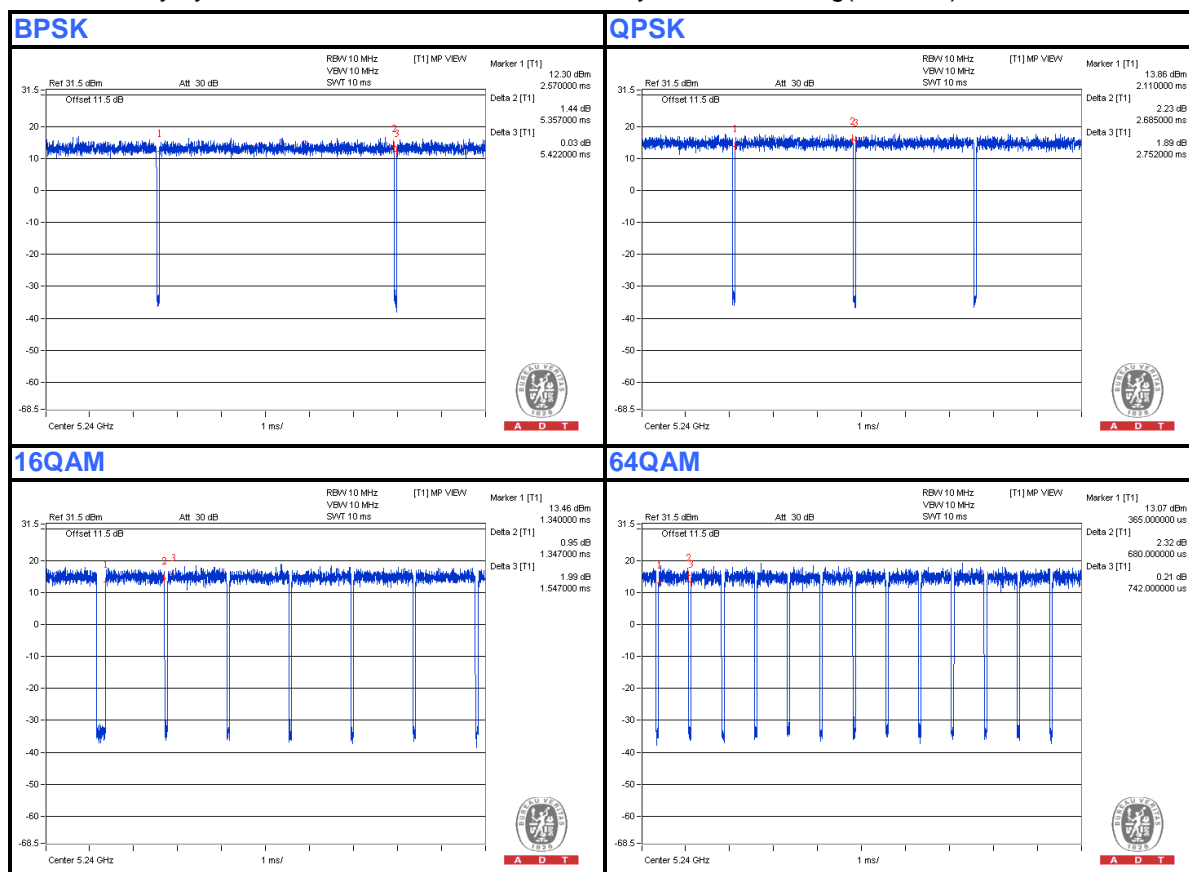



A D T

### 802.11ac (VHT20)

**BPSK:** Duty cycle = 4.972 ms/5.042 ms = 0.986

**QPSK:** Duty cycle = 2.493 ms/2.568 ms = 0.971, Duty factor =  $10 * \log(1/0.971) = 0.13$

**16QAM:** Duty cycle = 1.262 ms/1.327 ms = 0.951, Duty factor =  $10 * \log(1/0.951) = 0.22$

**64QAM:** Duty cycle = 0.655 ms/0.722 ms = 0.907, Duty factor =  $10 * \log(1/0.907) = 0.42$

**256QAM:** Duty cycle = 0.443 ms/0.508 ms = 0.872, Duty factor =  $10 * \log(1/0.872) = 0.59$







A D T

### 802.11ac (VHT40)

**BPSK:** Duty cycle = 2.414 ms/2.482 ms = 0.973, Duty factor =  $10 \cdot \log(1/0.973) = 0.12$

**QPSK:** Duty cycle = 1.227 ms/1.425 ms = 0.861, Duty factor =  $10 \cdot \log(1/0.861) = 0.65$

**16QAM:** Duty cycle = 0.63 ms/0.705 ms = 0.894, Duty factor =  $10 \cdot \log(1/0.894) = 0.49$

**64QAM:** Duty cycle = 0.333 ms/0.4 ms = 0.833, Duty factor =  $10 \cdot \log(1/0.833) = 0.8$

**256QAM:** Duty cycle = 0.24 ms/0.298 ms = 0.805, Duty factor =  $10 \cdot \log(1/0.805) = 0.94$

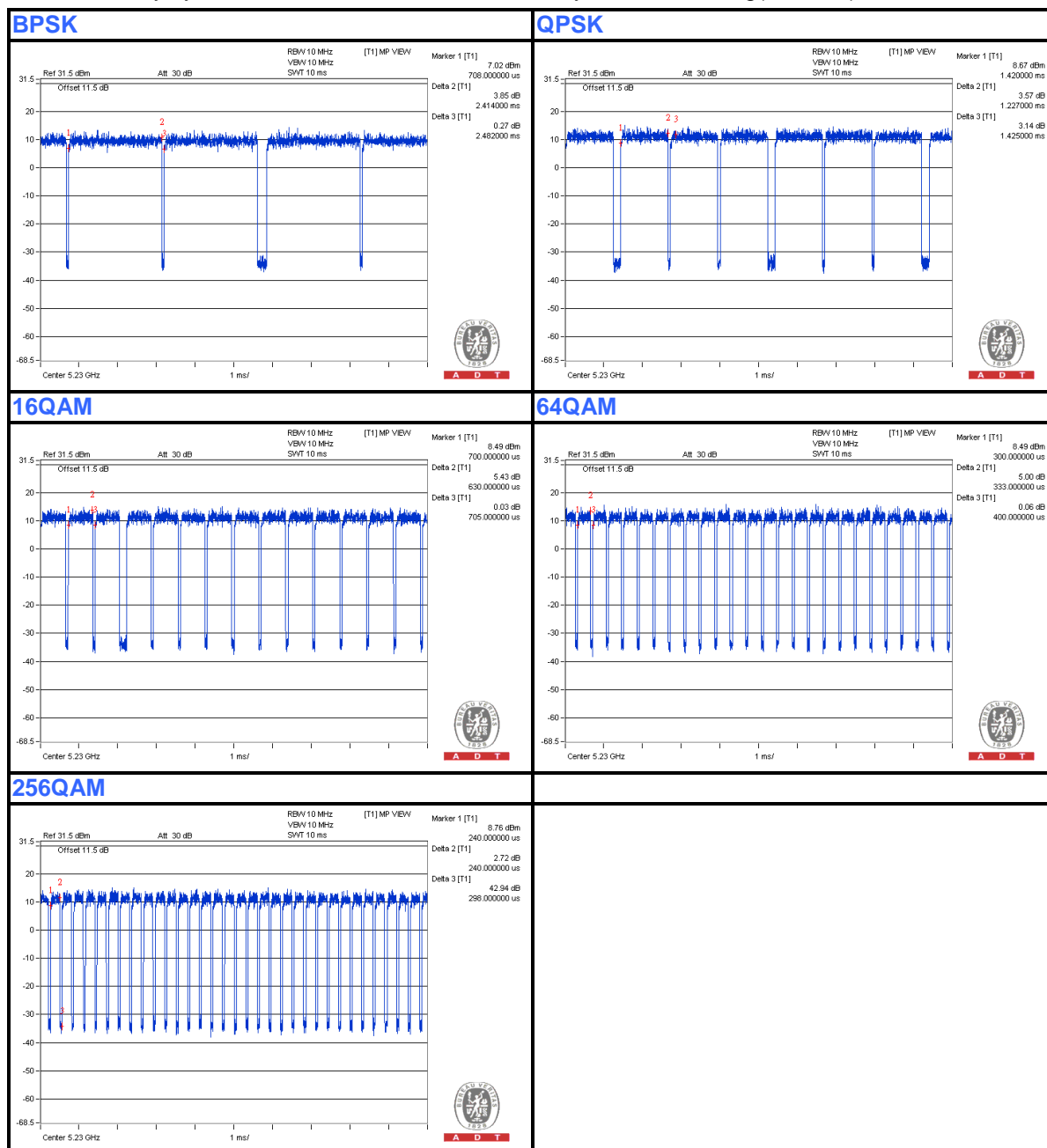



A D T

### 802.11ac (VHT80)

**BPSK:** Duty cycle = 1.13 ms/1.192 ms = 0.948, Duty factor =  $10 * \log(1/0.948) = 0.23$

**QPSK:** Duty cycle = 0.578 ms/0.658ms = 0.878, Duty factor =  $10 * \log(1/0.878) = 0.56$

**16QAM:** Duty cycle = 0.313 ms/0.378 ms = 0.828, Duty factor =  $10 * \log(1/0.828) = 0.82$

**64QAM:** Duty cycle = 0.175 ms/0.243 ms = 0.72, Duty factor =  $10 * \log(1/0.72) = 1.43$

**256QAM:** Duty cycle = 0.125 ms/0.19 ms = 0.658, Duty factor =  $10 * \log(1/0.658) = 1.82$





A D T

### 3.5 DESCRIPTION OF SUPPORT UNITS

The EUT has been tested as an independent unit together with other necessary accessories or support units. The following support units or accessories were used to form a representative test configuration during the tests.

No.	Product	Brand	Model No.	Serial No.	FCC ID	Remark
A	NOTEBOOK COMPUTER	DELL	E5430	HYV4VY1	FCC DoC	Provided by Lab
B	PoE	Power Dsine	PD-3501G/AC	NA	NA	Supplied by Client

**NOTE:**

1. All power cords of the above support units are non-shielded (1.8 m).

No.	Cable	Qty.	Length (m)	Shielded (Yes/ No)	Cores (Number)	Remark
1.	UTP	1	10	No	0	Provided by Lab
2.	DC	1	1.53	No	0	Supplied by Client
3.	UTP	1	1	No	0	Provided by Lab

### 3.6 CONFIGURATION OF SYSTEM UNDER TEST

For Adapter Mode:

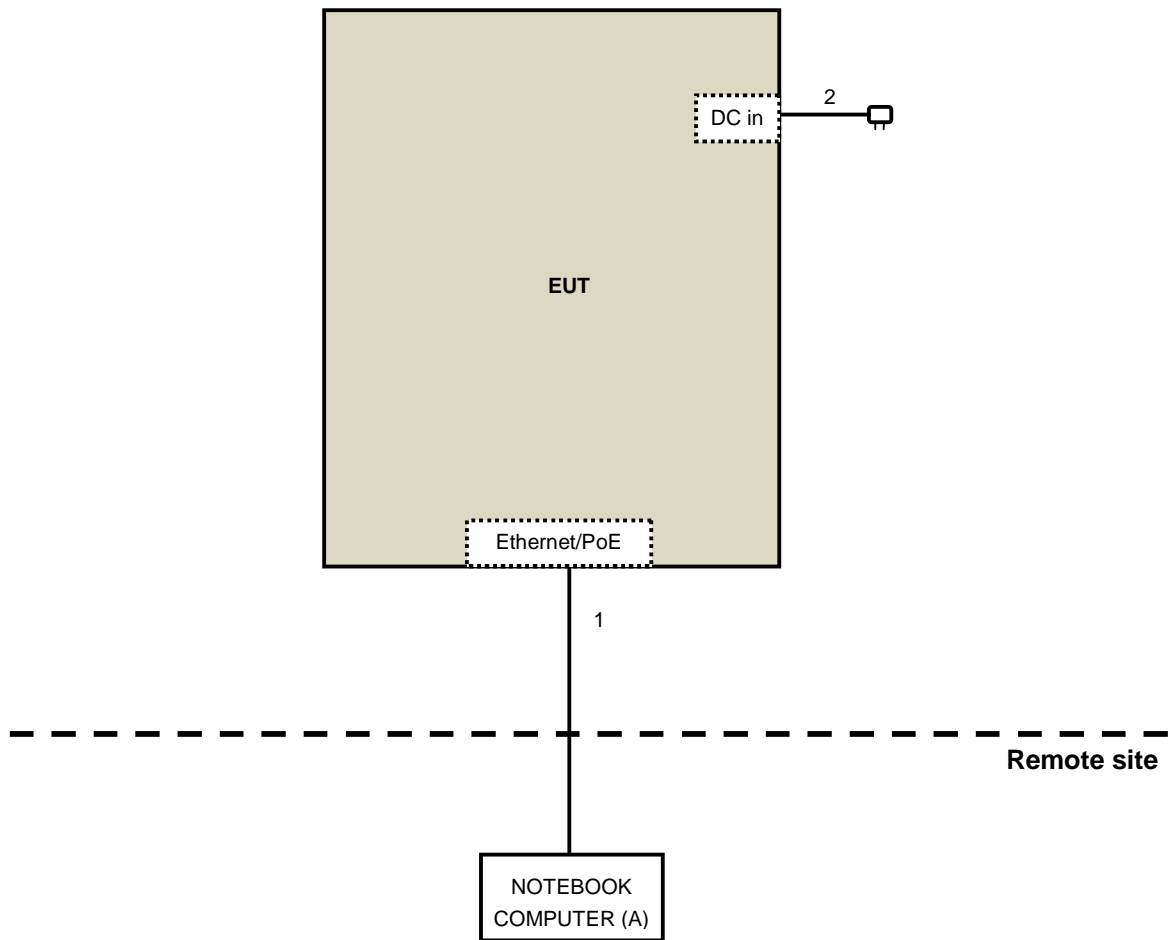



A D T

**For PoE Mode:**

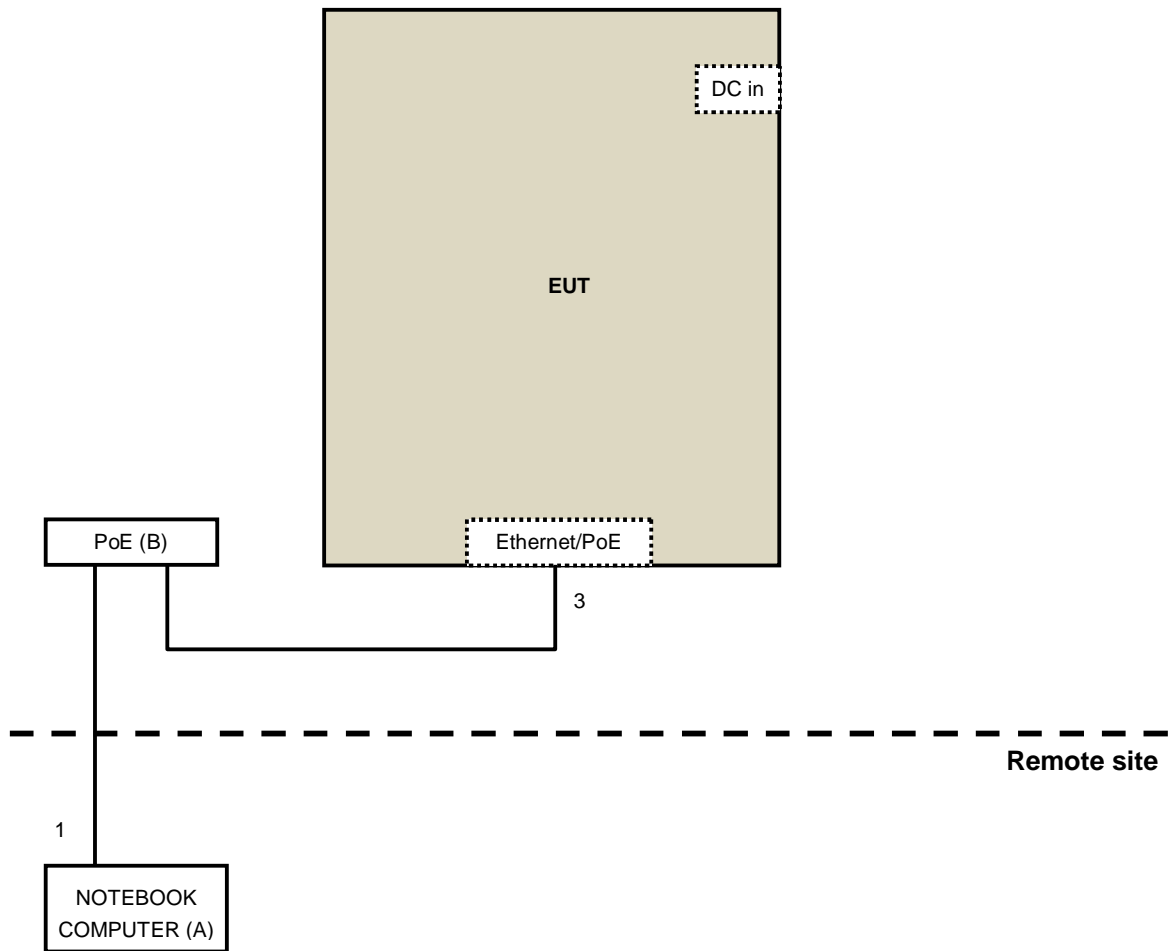



A D T

## 4. TEST TYPES AND RESULTS

### 4.1 CONDUCTED EMISSION MEASUREMENT

#### 4.1.1 LIMITS OF CONDUCTED EMISSION MEASUREMENT

FREQUENCY OF EMISSION (MHz)	CONDUCTED LIMIT (dB $\mu$ V)	
	Quasi-peak	Average
0.15-0.5	66 to 56	56 to 46
0.5-5	56	46
5-30	60	50

- NOTE:**
1. The lower limit shall apply at the transition frequencies.
  2. The limit decreases in line with the logarithm of the frequency in the range of 0.15 to 0.50 MHz.

#### 4.1.2 TEST INSTRUMENTS

DESCRIPTION & MANUFACTURER	MODEL NO.	SERIAL NO.	CALIBRATED DATE	CALIBRATED UNTIL
Test Receiver ROHDE & SCHWARZ	ESCS 30	100375	Apr. 29, 2014	Apr. 28, 2015
Line-Impedance Stabilization Network (for EUT) SCHWARZBECK	NSLK8127	8127-522	Sep. 12, 2013	Sep. 11, 2014
Line-Impedance Stabilization Network (for Peripheral)	ENV216	100071	Nov. 13, 2013	Nov. 12, 2014
RF Cable (JYEBAO)	5DFB	COCCAB-001	Mar. 10, 2014	Mar. 09, 2015
50 ohms Terminator	N/A	EMC-03	Sep. 24, 2013	Sep. 23, 2014
50 ohms Terminator	N/A	EMC-02	Oct. 01, 2013	Sep. 30, 2014
Software ADT	BV ADT_Cond_V7.3.7. 3	NA	NA	NA

**Note:**

1. The calibration interval of the above test instruments is 12 months and the calibrations are traceable to NML/ROC and NIST/USA.
2. The test was performed in Shielded Room No. C.
3. The VCCI Con C Registration No. is C-3611.
4. Tested Date: July 28, 2014

### 4.1.3 TEST PROCEDURES

- a. The EUT was placed 0.4 meters from the conducting wall of the shielded room with EUT being connected to the power mains through a line impedance stabilization network (LISN). Other support units were connected to the power mains through another LISN.
- b. The two LISNs provide 50 ohm/ 50uH of coupling impedance for the measuring instrument.
- c. Both lines of the power mains connected to the EUT were checked for maximum conducted interference.
- d. The frequency range from 150kHz to 30MHz was searched. Emission level under (Limit – 20dB) was not recorded.

#### NOTE:

1. The resolution bandwidth of test receiver is 9kHz for Quasi-peak detection (QP) & Average detection (AV).

### 4.1.4 DEVIATION FROM TEST STANDARD

No deviation

### 4.1.5 TEST SETUP

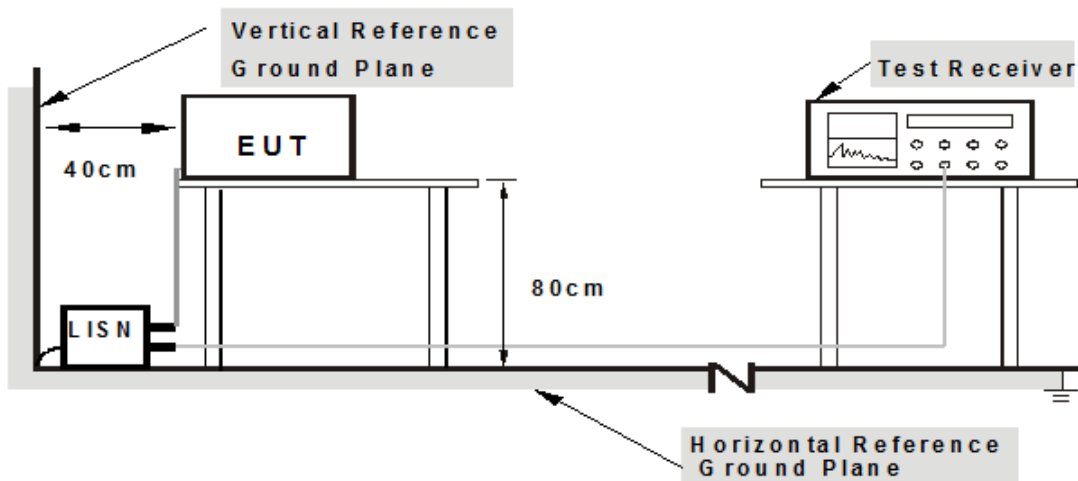

**Note: 1. Support units were connected to second LISN.**

For the actual test configuration, please refer to the related item – Photographs of the Test Configuration.

#### 4.1.6 EUT OPERATING CONDITIONS

1. Turn on the power of all equipment.
2. The support unit A (Notebook Computer) runs “Atheros Radio Test 2\_Version:2.3” program to enable EUT under transmission/receiving condition continuously at specific channel frequency.



#### 4.1.7 TEST RESULTS (Mode 1)

<b>PHASE</b>	Line (L)	<b>DETECTOR FUNCTION</b>	Quasi-Peak (QP) / Average (AV)
--------------	----------	--------------------------	--------------------------------

No	Freq. [MHz]	Corr. Factor (dB)	Reading Value [dB (uV)]		Emission Level [dB (uV)]		Limit [dB (uV)]		Margin (dB)	
			Q.P.	AV.	Q.P.	AV.	Q.P.	AV.	Q.P.	AV.
1	0.15000	0.07	49.30	38.12	49.37	38.19	66.00	56.00	-16.63	-17.81
2	0.35703	0.09	37.39	32.05	37.48	32.14	58.80	48.80	-21.32	-16.66
3	0.92734	0.13	25.67	22.53	25.80	22.66	56.00	46.00	-30.20	-23.34
4	7.78516	0.38	23.24	18.45	23.62	18.83	60.00	50.00	-36.38	-31.17
5	11.71875	0.50	27.77	23.17	28.27	23.67	60.00	50.00	-31.73	-26.33
6	23.12891	0.80	32.56	29.94	33.36	30.74	60.00	50.00	-26.64	-19.26

**REMARKS:**

1. Q.P. and AV. are abbreviations of quasi-peak and average individually.
2. The emission levels of other frequencies were very low against the limit.
3. Margin value = Emission Level – Limit value
4. Correction Factor = Insertion loss + Cable loss
5. Emission Level = Correction Factor + Reading Value

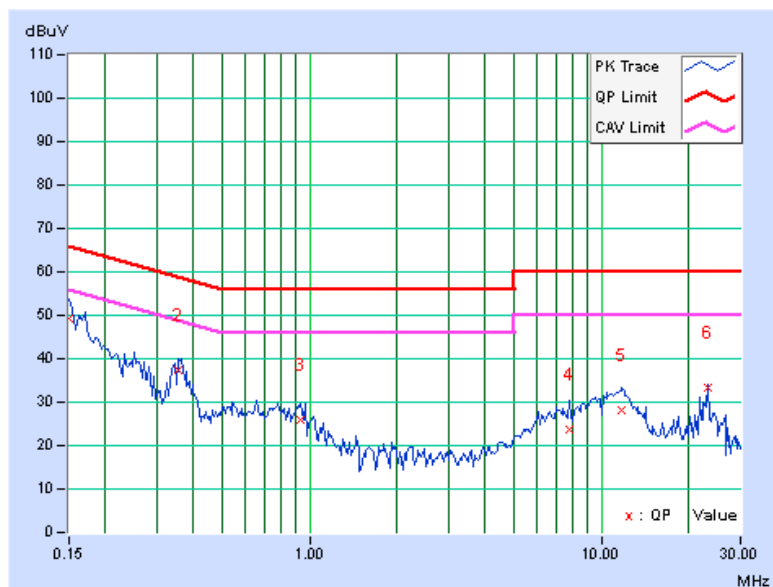

<b>PHASE</b>	Neutral (N)	<b>DETECTOR FUNCTION</b>	Quasi-Peak (QP) / Average (AV)
--------------	-------------	--------------------------	--------------------------------

No	Freq.	Corr.	Reading Value		Emission Level		Limit		Margin	
	[MHz]	(dB)	Q.P.	AV.	Q.P.	AV.	Q.P.	AV.	Q.P.	AV.
1	0.15000	0.08	49.64	38.89	49.72	38.97	66.00	56.00	-16.28	-17.03
2	0.20469	0.07	40.06	29.30	40.13	29.37	63.42	53.42	-23.29	-24.05
3	0.36484	0.09	38.97	33.52	39.06	33.61	58.62	48.62	-19.56	-15.01
4	6.59375	0.34	27.67	22.56	28.01	22.90	60.00	50.00	-31.99	-27.10
5	10.98438	0.48	29.98	25.60	30.46	26.08	60.00	50.00	-29.54	-23.92
6	21.66406	0.75	30.34	26.87	31.09	27.62	60.00	50.00	-28.91	-22.38

**REMARKS:**

1. Q.P. and AV. are abbreviations of quasi-peak and average individually.
2. The emission levels of other frequencies were very low against the limit.
3. Margin value = Emission Level – Limit value
4. Correction Factor = Insertion loss + Cable loss
5. Emission Level = Correction Factor + Reading Value

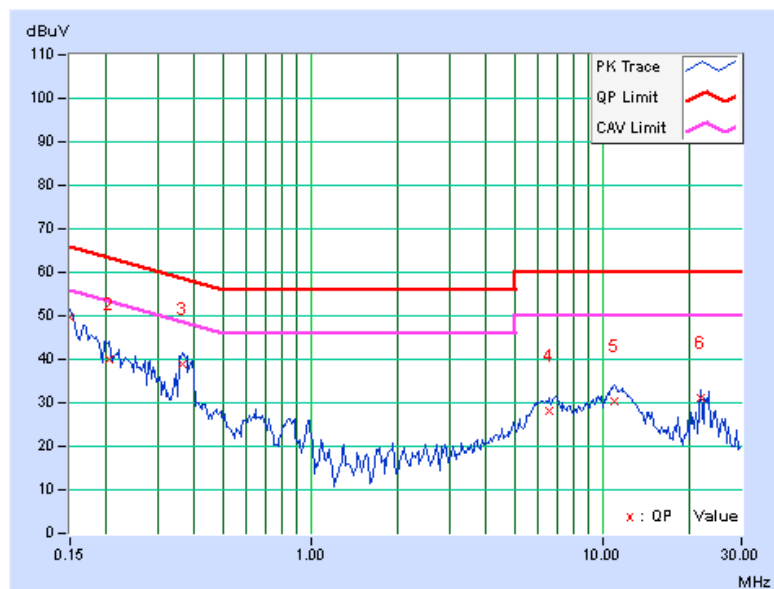

#### 4.1.8 TEST RESULTS (Mode 2)

<b>PHASE</b>	Line (L)	<b>DETECTOR FUNCTION</b>	Quasi-Peak (QP) / Average (AV)
--------------	----------	--------------------------	--------------------------------

No	Freq. [MHz]	Corr. Factor (dB)	Reading Value		Emission Level		Limit		Margin	
			[dB (uV)]		[dB (uV)]		[dB (uV)]		(dB)	
			Q.P.	AV.	Q.P.	AV.	Q.P.	AV.	Q.P.	AV.
1	0.15000	0.07	45.32	36.39	45.39	36.46	66.00	56.00	-20.61	-19.54
2	0.19109	0.07	39.38	30.83	39.45	30.90	63.99	53.99	-24.54	-23.09
3	0.52109	0.10	37.02	33.34	37.12	33.44	56.00	46.00	-18.88	-12.56
4	3.73828	0.25	26.11	18.87	26.36	19.12	56.00	46.00	-29.64	-26.88
5	11.47266	0.49	39.67	38.99	40.16	39.48	60.00	50.00	-19.84	-10.52
6	23.00781	0.79	42.34	36.71	43.13	37.50	60.00	50.00	-16.87	-12.50

#### REMARKS:

1. Q.P. and AV. are abbreviations of quasi-peak and average individually.
2. The emission levels of other frequencies were very low against the limit.
3. Margin value = Emission Level – Limit value
4. Correction Factor = Insertion loss + Cable loss
5. Emission Level = Correction Factor + Reading Value

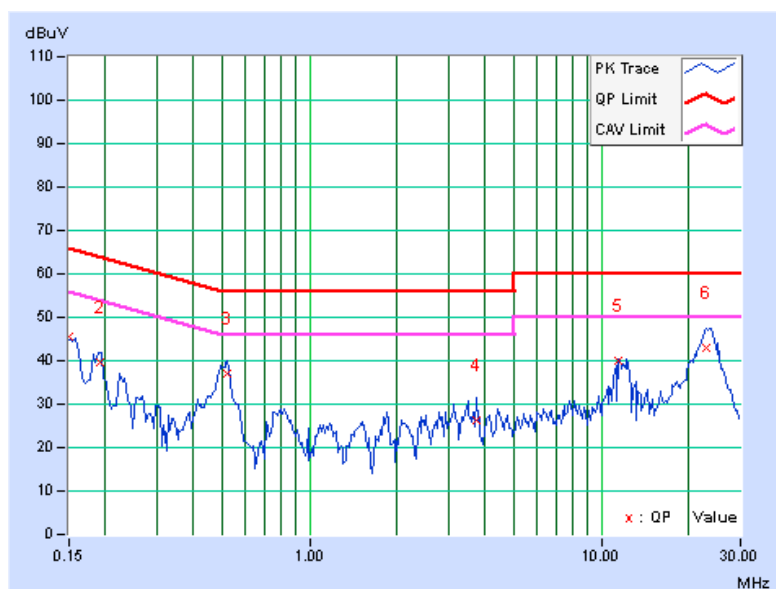

<b>PHASE</b>	Neutral (N)	<b>DETECTOR FUNCTION</b>	Quasi-Peak (QP) / Average (AV)
--------------	-------------	--------------------------	--------------------------------

No	Freq.	Corr.	Reading Value		Emission Level		Limit		Margin	
	[MHz]	(dB)	Q.P.	AV.	Q.P.	AV.	Q.P.	AV.	Q.P.	AV.
1	0.15000	0.08	45.32	37.08	45.40	37.16	66.00	56.00	-20.60	-18.84
2	0.18906	0.07	40.00	31.94	40.07	32.01	64.08	54.08	-24.01	-22.07
3	0.52109	0.10	37.95	34.41	38.05	34.51	56.00	46.00	-17.95	-11.49
4	3.13281	0.23	27.71	22.05	27.94	22.28	56.00	46.00	-28.06	-23.72
<b>5</b>	<b>11.47266</b>	<b>0.49</b>	<b>40.08</b>	<b>39.30</b>	<b>40.57</b>	<b>39.79</b>	<b>60.00</b>	<b>50.00</b>	<b>-19.43</b>	<b>-10.21</b>
6	22.91797	0.78	43.35	37.72	44.13	38.50	60.00	50.00	-15.87	-11.50

**REMARKS:**

1. Q.P. and AV. are abbreviations of quasi-peak and average individually.
2. The emission levels of other frequencies were very low against the limit.
3. Margin value = Emission Level – Limit value
4. Correction Factor = Insertion loss + Cable loss
5. Emission Level = Correction Factor + Reading Value

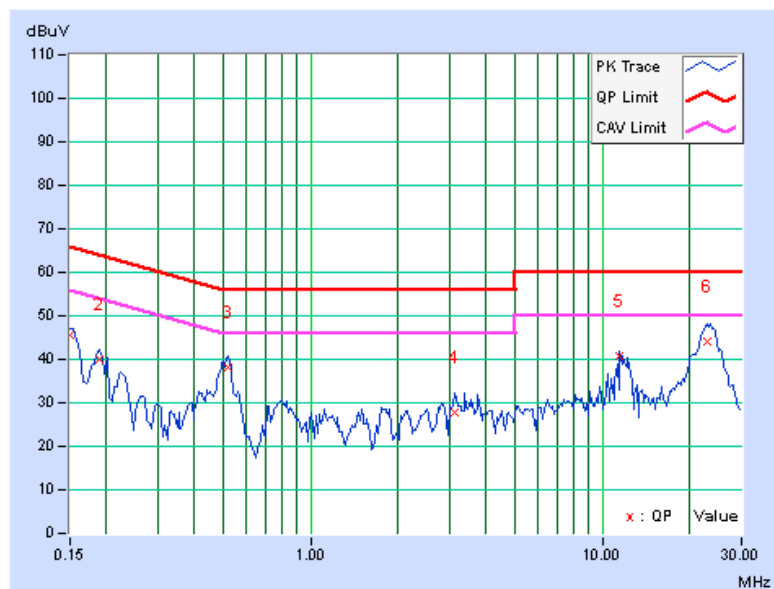



## 4.2 RADIATED EMISSION AND BANDEGE MEASUREMENT

### 4.2.1 LIMITS OF RADIATED EMISSION AND BANDEGE MEASUREMENT

Radiated emissions which fall in the restricted bands must comply with the radiated emission limits specified as below table:

Frequencies (MHz)	Field strength (microvolts/meter)	Measurement distance (meters)
0.009-0.490	2400/F(kHz)	300
0.490-1.705	24000/F(kHz)	30
1.705-30.0	30	30
30-88	100	3
88-216	150	3
216-960	200	3
Above 960	500	3

**NOTE:**

1. The lower limit shall apply at the transition frequencies.
2. Emission level (dBuV/m) = 20 log Emission level (uV/m).
3. For frequencies above 1000MHz, the field strength limits are based on average detector, however, the peak field strength of any emission shall not exceed the maximum permitted average limits, specified above by more than 20dB under any condition of modulation.

### 4.2.2 LIMITS OF UNWANTED EMISSION OUT OF THE RESTRICTED BANDS

LIMIT	
FIELD STRENGTH AT 3m (dBµV/m)	
PK	AV
74	54
EIRP LIMIT (dBm)	EQUIVALENT FIELD STRENGTH AT 3m (dBµV/m)
PK	PK
-27	68.2

**NOTE:**

1. The following formula is used to convert the equipment isotropic radiated power (eirp) to field strength:

$$E = \frac{1000000\sqrt{30P}}{3} \mu\text{V/m, where P is the eirp (Watts).$$



A D T

### 4.2.3 TEST INSTRUMENTS

DESCRIPTION & MANUFACTURER	MODEL NO.	SERIAL NO.	CALIBRATED DATE	CALIBRATED UNTIL
MXE EMI Receiver Agilent	N9038A	MY51210105	July 21,2014	July 20,2015
Pre-Amplifier Mini-Circuits	ZFL-1000VH2 B	AMP-ZFL-03	Nov. 13, 2013	Nov. 12, 2014
Trilog Broadband Antenna SCHWARZBECK	VULB 9168	9168-360	Feb. 26, 2014	Feb. 25, 2015
RF Cable	NA	CHGCAB_001	Oct. 05, 2013	Oct. 04, 2014
Spectrum Analyzer R&S	FSV40	100964	July 05, 2014	July 04, 2015
Horn_Antenna AISI	AIH.8018	0000320091110	Nov. 18, 2013	Nov. 17, 2014
Pre-Amplifier Agilent	8449B	3008A02578	June 24, 2014	June 23, 2015
RF Cable	NA	RF104-201 RF104-203 RF104-204	Dec. 12, 2013	Dec. 11, 2014
Spectrum Analyzer Agilent	E4446A	MY48250253	Aug. 28, 2013	Aug. 27, 2014
Pre-Amplifier SPACEK LABS	SLKKa-48-6	9K16	Nov. 13, 2013	Nov. 12, 2014
Horn_Antenna SCHWARZBECK	BBHA 9170	9170-424	Oct. 08, 2013	Oct. 07, 2014
Software	ADT_Radiated _V8.7.07	NA	NA	NA
Antenna Tower & Turn Table CT	NA	NA	NA	NA

**Note:**

1. The calibration interval of the above test instruments is 12 months and the calibrations are traceable to NML/ROC and NIST/USA.
2. The horn antenna, preamplifier (model: 8449B) are used only for the measurement of emission frequency above 1GHz if tested.
- 3 The test was performed in 966 Chamber No. G.
4. The FCC Site Registration No. is 966073.
- 5 The VCCI Site Registration No. is G-137.
- 6 The CANADA Site Registration No. is IC 7450H-2.
- 7 Tested Date: July 28 to Aug. 08, 2014

#### 4.2.4 TEST PROCEDURES

- a. The EUT was placed on the top of a rotating table 0.8 meters above the ground at 3 meter chamber room for test. The table was rotated 360 degrees to determine the position of the highest radiation.
- b. The EUT was set 3 meters away from the interference-receiving antenna, which was mounted on the top of a variable-height antenna tower.
- c. The height of antenna is varied from one meter to four meters above the ground to determine the maximum value of the field strength. Both horizontal and vertical polarizations of the antenna are set to make the measurement.
- d. For each suspected emission, the EUT was arranged to its worst case and then the antenna was tuned to heights from 1 meter to 4 meters and the rotatable table was turned from 0 degrees to 360 degrees to find the maximum reading.
- e. The test-receiver system was set to quasi-peak detect function and specified bandwidth with maximum hold mode when the test frequency is below 1 GHz.
- f. The test-receiver system was set to peak and average detect function and specified bandwidth with maximum hold mode when the test frequency is above 1 GHz. If the peak reading value also meets average limit, measurement with the average detector is unnecessary.

**Note:**

1. The resolution bandwidth and video bandwidth of test receiver/spectrum analyzer is 120kHz for Quasi-peak detection (QP) at frequency below 1GHz.
2. The resolution bandwidth of test receiver/spectrum analyzer is 1 MHz and the video bandwidth is 3 MHz for Peak detection (PK) at frequency above 1GHz.
3. The resolution bandwidth of test receiver/spectrum analyzer is 1MHz and the video bandwidth is 3MHz for RMS Average (Duty cycle < 98%) for Average detection (AV) at frequency above 1GHz, then the measurement results was added to a correction factor ( $10 \log(1/\text{duty cycle})$ ).
4. The resolution bandwidth of test receiver/spectrum analyzer is 1MHz and the video bandwidth is 10Hz (Duty cycle  $\geq 98\%$ ) for Average detection (AV) at frequency above 1GHz.
5. All modes of operation were investigated and the worst-case emissions are reported.

#### 4.2.5 DEVIATION FROM TEST STANDARD

No deviation

#### 4.2.6 TEST SETUP

##### <Frequency Range below 1GHz>

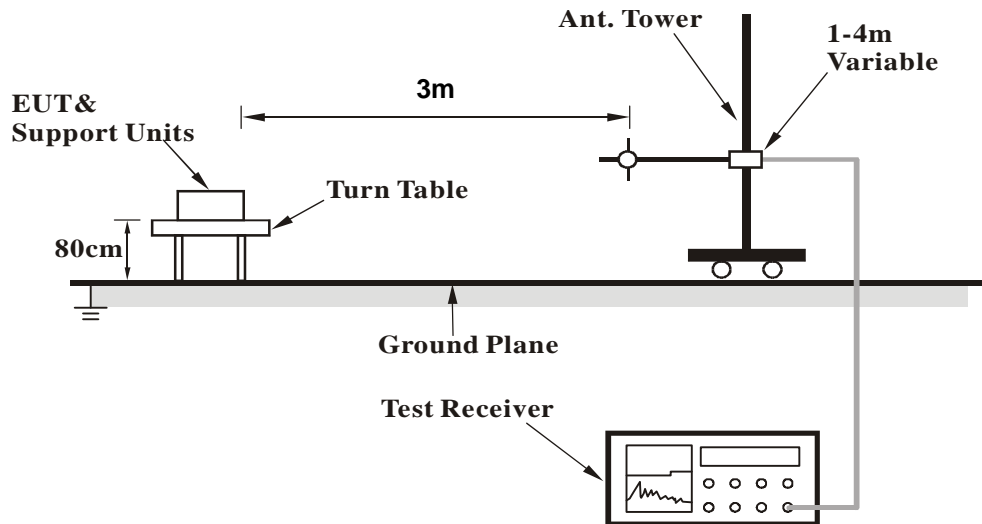

##### <Frequency Range above 1GHz>

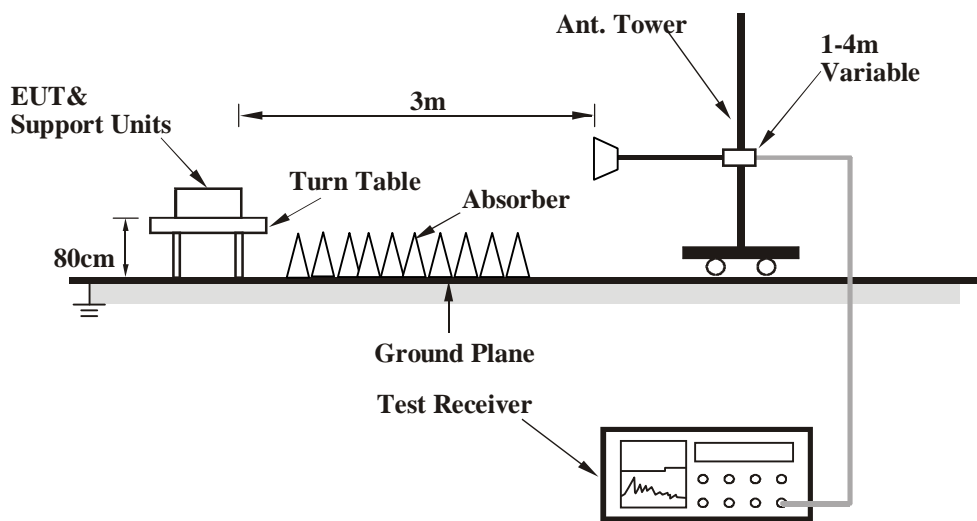

For the actual test configuration, please refer to the related item – Photographs of the Test Configuration.

#### 4.2.7 EUT OPERATING CONDITION

Same as 4.1.6





A D T

### 4.2.8 TEST RESULTS

#### BELOW 1GHz WORST-CASE DATA

##### 802.11ac (VHT40)

<b>CHANNEL</b>	TX Channel 46	<b>DETECTOR FUNCTION</b>	Quasi-Peak (QP)
<b>FREQUENCY RANGE</b>	Below 1GHz		

#### ANTENNA POLARITY & TEST DISTANCE: HORIZONTAL AT 3 M

NO.	FREQ. (MHz)	EMISSION LEVEL (dBuV/m)	LIMIT (dBuV/m)	MARGIN (dB)	ANTENNA HEIGHT (m)	TABLE ANGLE (Degree)	RAW VALUE (dBuV)	CORRECTION FACTOR (dB/m)
1	60.65	30.8 QP	40.0	-9.2	1.50 H	218	45.00	-14.21
2	258.34	38.0 QP	46.0	-8.0	2.00 H	145	52.02	-13.99
3	340.01	38.8 QP	46.0	-7.3	1.50 H	274	50.05	-11.30
4	401.90	36.1 QP	46.0	-9.9	2.00 H	118	45.75	-9.69
5	875.02	37.8 QP	46.0	-8.2	1.00 H	205	38.25	-0.45
6	1000.00	44.4 QP	54.0	-9.6	1.00 H	154	42.90	1.46

#### ANTENNA POLARITY & TEST DISTANCE: VERTICAL AT 3 M

NO.	FREQ. (MHz)	EMISSION LEVEL (dBuV/m)	LIMIT (dBuV/m)	MARGIN (dB)	ANTENNA HEIGHT (m)	TABLE ANGLE (Degree)	RAW VALUE (dBuV)	CORRECTION FACTOR (dB/m)
1	47.36	31.4 QP	40.0	-8.6	1.51 V	203	44.90	-13.52
2	118.03	34.4 QP	43.5	-9.1	1.50 V	143	49.73	-15.31
3	141.21	35.1 QP	43.5	-8.4	1.50 V	188	48.67	-13.61
4	409.61	33.5 QP	46.0	-12.5	1.50 V	211	43.01	-9.52
5	625.00	33.8 QP	46.0	-12.2	1.00 V	115	38.17	-4.41
6	999.95	40.1 QP	54.0	-13.9	1.00 V	241	38.60	1.46

#### REMARKS:

1. Emission Level(dBuV/m) = Raw Value(dBuV) + Correction Factor(dB/m)
2. Correction Factor(dB/m) = Antenna Factor(dB/m) + Cable Factor(dB) – Pre-Amplifier Factor(dB)
3. The other emission levels were very low against the limit.
4. Margin value = Emission Level – Limit value



A D T

**ABOVE 1GHz DATA**

**802.11a**

<b>CHANNEL</b>	TX Channel 36	<b>DETECTOR FUNCTION</b>	Peak (PK)
<b>FREQUENCY RANGE</b>	1GHz ~ 40GHz		Average (AV)

**ANTENNA POLARITY & TEST DISTANCE: HORIZONTAL AT 3 M**

NO.	FREQ. (MHz)	EMISSION LEVEL (dBuV/m)	LIMIT (dBuV/m)	MARGIN (dB)	ANTENNA HEIGHT (m)	TABLE ANGLE (Degree)	RAW VALUE (dBuV)	CORRECTION FACTOR (dB/m)
1	5150.00	51.6 PK	74.0	-22.4	1.00 H	153	44.80	6.80
2	5150.00	38.9 AV	54.0	-15.1	1.00 H	153	32.10	6.80
3	*5180.00	101.5 PK			1.00 H	153	94.55	6.95
4	*5180.00	91.9 AV			1.00 H	153	84.95	6.95
5	#10360.00	58.0 PK	74.0	-16.0	1.25 H	67	44.89	13.11
6	#10360.00	45.0 AV	54.0	-9.0	1.25 H	67	31.89	13.11
7	15540.00	60.1 PK	74.0	-13.9	1.06 H	318	41.41	18.69
8	15540.00	48.0 AV	54.0	-6.0	1.06 H	318	29.31	18.69

**ANTENNA POLARITY & TEST DISTANCE: VERTICAL AT 3 M**

NO.	FREQ. (MHz)	EMISSION LEVEL (dBuV/m)	LIMIT (dBuV/m)	MARGIN (dB)	ANTENNA HEIGHT (m)	TABLE ANGLE (Degree)	RAW VALUE (dBuV)	CORRECTION FACTOR (dB/m)
1	5150.00	56.1 PK	74.0	-17.9	1.41 V	133	49.30	6.80
2	5150.00	43.4 AV	54.0	-10.6	1.41 V	133	36.60	6.80
3	*5180.00	114.0 PK			1.41 V	133	107.05	6.95
4	*5180.00	103.2 AV			1.41 V	133	96.25	6.95
5	#10360.00	57.8 PK	74.0	-16.2	1.00 V	4	44.69	13.11
6	#10360.00	44.1 AV	54.0	-9.9	1.00 V	4	30.99	13.11
7	15540.00	61.1 PK	74.0	-12.9	1.11 V	14	42.41	18.69
8	15540.00	48.6 AV	54.0	-5.4	1.11 V	14	29.91	18.69

**REMARKS:**

1. Emission Level(dBuV/m) = Raw Value(dBuV) + Correction Factor(dB/m)
2. Correction Factor(dB/m) = Antenna Factor(dB/m) + Cable Factor(dB) – Pre-Amplifier Factor(dB)
3. The other emission levels were very low against the limit.
4. Margin value = Emission Level – Limit value
5. " \* ": Fundamental frequency.
6. " # ": The radiated frequency is out of the restricted band.



A D T

<b>CHANNEL</b>	TX Channel 40	<b>DETECTOR FUNCTION</b>	Peak (PK)
<b>FREQUENCY RANGE</b>	1GHz ~ 40GHz		Average (AV)

**ANTENNA POLARITY & TEST DISTANCE: HORIZONTAL AT 3 M**

NO.	FREQ. (MHz)	EMISSION LEVEL (dBuV/m)	LIMIT (dBuV/m)	MARGIN (dB)	ANTENNA HEIGHT (m)	TABLE ANGLE (Degree)	RAW VALUE (dBuV)	CORRECTION FACTOR (dB/m)
1	*5200.00	102.0 PK			1.04 H	156	94.95	7.05
2	*5200.00	92.2 AV			1.04 H	156	85.15	7.05
3	#10400.00	58.4 PK	74.0	-15.6	1.19 H	53	45.18	13.22
4	#10400.00	45.4 AV	54.0	-8.6	1.19 H	53	32.18	13.22
5	15600.00	60.6 PK	74.0	-13.4	1.02 H	306	41.90	18.70
6	15600.00	48.4 AV	54.0	-5.6	1.02 H	306	29.70	18.70

**ANTENNA POLARITY & TEST DISTANCE: VERTICAL AT 3 M**

NO.	FREQ. (MHz)	EMISSION LEVEL (dBuV/m)	LIMIT (dBuV/m)	MARGIN (dB)	ANTENNA HEIGHT (m)	TABLE ANGLE (Degree)	RAW VALUE (dBuV)	CORRECTION FACTOR (dB/m)
1	*5200.00	113.7 PK			1.40 V	134	106.65	7.05
2	*5200.00	102.7 AV			1.40 V	134	95.65	7.05
3	#10400.00	57.6 PK	74.0	-16.4	1.03 V	1	44.38	13.22
4	#10400.00	43.8 AV	54.0	-10.2	1.03 V	1	30.58	13.22
5	15600.00	61.3 PK	74.0	-12.7	1.16 V	16	42.60	18.70
6	15600.00	48.9 AV	54.0	-5.1	1.16 V	16	30.20	18.70

**REMARKS:**

1. Emission Level(dBuV/m) = Raw Value(dBuV) + Correction Factor(dB/m)
2. Correction Factor(dB/m) = Antenna Factor(dB/m) + Cable Factor(dB) – Pre-Amplifier Factor(dB)
3. The other emission levels were very low against the limit.
4. Margin value = Emission Level – Limit value
5. " \* ": Fundamental frequency.
6. " # ": The radiated frequency is out of the restricted band.



A D T

<b>CHANNEL</b>	TX Channel 48	<b>DETECTOR FUNCTION</b>	Peak (PK)
<b>FREQUENCY RANGE</b>	1GHz ~ 40GHz		Average (AV)

**ANTENNA POLARITY & TEST DISTANCE: HORIZONTAL AT 3 M**

NO.	FREQ. (MHz)	EMISSION LEVEL (dBuV/m)	LIMIT (dBuV/m)	MARGIN (dB)	ANTENNA HEIGHT (m)	TABLE ANGLE (Degree)	RAW VALUE (dBuV)	CORRECTION FACTOR (dB/m)
1	*5240.00	101.0 PK			1.01 H	149	93.84	7.16
2	*5240.00	91.6 AV			1.01 H	149	84.44	7.16
3	5350.00	50.3 PK	74.0	-23.7	1.01 H	149	42.81	7.49
4	5350.00	37.4 AV	54.0	-16.6	1.01 H	149	29.91	7.49
5	#10480.00	57.9 PK	74.0	-16.1	1.19 H	70	44.74	13.16
6	#10480.00	44.8 AV	54.0	-9.2	1.19 H	70	31.64	13.16
7	15720.00	60.5 PK	74.0	-13.5	1.00 H	309	42.10	18.40
8	15720.00	48.4 AV	54.0	-5.6	1.00 H	309	30.00	18.40

**ANTENNA POLARITY & TEST DISTANCE: VERTICAL AT 3 M**

NO.	FREQ. (MHz)	EMISSION LEVEL (dBuV/m)	LIMIT (dBuV/m)	MARGIN (dB)	ANTENNA HEIGHT (m)	TABLE ANGLE (Degree)	RAW VALUE (dBuV)	CORRECTION FACTOR (dB/m)
1	*5240.00	113.2 PK			1.39 V	131	106.04	7.16
2	*5240.00	102.6 AV			1.39 V	131	95.44	7.16
3	5350.00	53.8 PK	74.0	-20.2	1.39 V	131	46.31	7.49
4	5350.00	42.0 AV	54.0	-12.0	1.39 V	131	34.51	7.49
5	#10480.00	57.8 PK	74.0	-16.2	1.00 V	6	44.64	13.16
6	#10480.00	44.2 AV	54.0	-9.8	1.00 V	6	31.04	13.16
7	15720.00	61.1 PK	74.0	-12.9	1.11 V	0	42.70	18.40
8	15720.00	48.6 AV	54.0	-5.4	1.11 V	0	30.20	18.40

**REMARKS:**

1. Emission Level(dBuV/m) = Raw Value(dBuV) + Correction Factor(dB/m)
2. Correction Factor(dB/m) = Antenna Factor(dB/m) + Cable Factor(dB) – Pre-Amplifier Factor(dB)
3. The other emission levels were very low against the limit.
4. Margin value = Emission Level – Limit value
5. " \* ": Fundamental frequency.
6. " # ": The radiated frequency is out of the restricted band.



A D T

802.11ac (VHT20)

<b>CHANNEL</b>	TX Channel 36	<b>DETECTOR FUNCTION</b>	Peak (PK)
<b>FREQUENCY RANGE</b>	1GHz ~ 40GHz		Average (AV)

**ANTENNA POLARITY & TEST DISTANCE: HORIZONTAL AT 3 M**

NO.	FREQ. (MHz)	EMISSION LEVEL (dBuV/m)	LIMIT (dBuV/m)	MARGIN (dB)	ANTENNA HEIGHT (m)	TABLE ANGLE (Degree)	RAW VALUE (dBuV)	CORRECTION FACTOR (dB/m)
1	5150.00	57.6 PK	74.0	-16.4	1.07 H	152	50.80	6.80
2	5150.00	45.3 AV	54.0	-8.7	1.07 H	152	38.50	6.80
3	*5180.00	104.5 PK			1.10 H	160	97.55	6.95
4	*5180.00	94.7 AV			1.10 H	160	87.75	6.95
5	#10360.00	60.1 PK	74.0	-13.9	1.22 H	74	46.99	13.11
6	#10360.00	47.4 AV	54.0	-6.6	1.22 H	74	34.29	13.11
7	15540.00	61.7 PK	74.0	-12.3	1.05 H	294	43.01	18.69
8	15540.00	49.9 AV	54.0	-4.1	1.05 H	294	31.21	18.69

**ANTENNA POLARITY & TEST DISTANCE: VERTICAL AT 3 M**

NO.	FREQ. (MHz)	EMISSION LEVEL (dBuV/m)	LIMIT (dBuV/m)	MARGIN (dB)	ANTENNA HEIGHT (m)	TABLE ANGLE (Degree)	RAW VALUE (dBuV)	CORRECTION FACTOR (dB/m)
1	5150.00	59.9 PK	74.0	-14.1	1.42 V	135	53.10	6.80
2	5150.00	47.0 AV	54.0	-7.0	1.42 V	135	40.20	6.80
3	*5180.00	116.1 PK			1.42 V	135	109.15	6.95
4	*5180.00	105.1 AV			1.42 V	135	98.15	6.95
5	#10360.00	61.4 PK	74.0	-12.6	1.03 V	35	48.29	13.11
6	#10360.00	46.8 AV	54.0	-7.2	1.03 V	35	33.69	13.11
7	15540.00	65.3 PK	74.0	-8.7	1.02 V	22	46.61	18.69
8	15540.00	52.2 AV	54.0	-1.8	1.02 V	22	33.51	18.69

**REMARKS:**

1. Emission Level(dBuV/m) = Raw Value(dBuV) + Correction Factor(dB/m)
2. Correction Factor(dB/m) = Antenna Factor(dB/m) + Cable Factor(dB) – Pre-Amplifier Factor(dB)
3. The other emission levels were very low against the limit.
4. Margin value = Emission Level – Limit value
5. " \* ": Fundamental frequency.
6. " # ": The radiated frequency is out of the restricted band.



A D T

<b>CHANNEL</b>	TX Channel 40	<b>DETECTOR FUNCTION</b>	Peak (PK)
<b>FREQUENCY RANGE</b>	1GHz ~ 40GHz		Average (AV)

**ANTENNA POLARITY & TEST DISTANCE: HORIZONTAL AT 3 M**

NO.	FREQ. (MHz)	EMISSION LEVEL (dBuV/m)	LIMIT (dBuV/m)	MARGIN (dB)	ANTENNA HEIGHT (m)	TABLE ANGLE (Degree)	RAW VALUE (dBuV)	CORRECTION FACTOR (dB/m)
1	*5200.00	105.2 PK			1.13 H	166	98.15	7.05
2	*5200.00	95.1 AV			1.13 H	166	88.05	7.05
3	#10400.00	59.4 PK	74.0	-14.6	1.24 H	73	46.18	13.22
4	#10400.00	47.0 AV	54.0	-7.0	1.24 H	73	33.78	13.22
5	15600.00	62.4 PK	74.0	-11.6	1.02 H	308	43.70	18.70
6	15600.00	50.4 AV	54.0	-3.6	1.02 H	308	31.70	18.70

**ANTENNA POLARITY & TEST DISTANCE: VERTICAL AT 3 M**

NO.	FREQ. (MHz)	EMISSION LEVEL (dBuV/m)	LIMIT (dBuV/m)	MARGIN (dB)	ANTENNA HEIGHT (m)	TABLE ANGLE (Degree)	RAW VALUE (dBuV)	CORRECTION FACTOR (dB/m)
1	*5200.00	116.3 PK			1.42 V	128	109.25	7.05
2	*5200.00	105.1 AV			1.42 V	128	98.05	7.05
3	#10400.00	61.3 PK	74.0	-12.7	1.00 V	44	48.08	13.22
4	#10400.00	46.5 AV	54.0	-7.5	1.00 V	44	33.28	13.22
5	15600.00	64.9 PK	74.0	-9.1	1.02 V	28	46.20	18.70
6	15600.00	51.7 AV	54.0	-2.3	1.02 V	28	33.00	18.70

**REMARKS:**

1. Emission Level(dBuV/m) = Raw Value(dBuV) + Correction Factor(dB/m)
2. Correction Factor(dB/m) = Antenna Factor(dB/m) + Cable Factor(dB) – Pre-Amplifier Factor(dB)
3. The other emission levels were very low against the limit.
4. Margin value = Emission Level – Limit value
5. " \* ": Fundamental frequency.
6. " # ": The radiated frequency is out of the restricted band.



A D T

<b>CHANNEL</b>	TX Channel 48	<b>DETECTOR FUNCTION</b>	Peak (PK)
<b>FREQUENCY RANGE</b>	1GHz ~ 40GHz		Average (AV)

**ANTENNA POLARITY & TEST DISTANCE: HORIZONTAL AT 3 M**

NO.	FREQ. (MHz)	EMISSION LEVEL (dBuV/m)	LIMIT (dBuV/m)	MARGIN (dB)	ANTENNA HEIGHT (m)	TABLE ANGLE (Degree)	RAW VALUE (dBuV)	CORRECTION FACTOR (dB/m)
1	*5240.00	105.0 PK			1.19 H	179	97.84	7.16
2	*5240.00	95.0 AV			1.19 H	179	87.84	7.16
3	5350.00	57.1 PK	74.0	-16.9	1.08 H	163	49.61	7.49
4	5350.00	45.1 AV	54.0	-8.9	1.08 H	163	37.61	7.49
5	#10480.00	59.8 PK	74.0	-14.2	1.22 H	64	46.64	13.16
6	#10480.00	47.3 AV	54.0	-6.7	1.22 H	64	34.14	13.16
7	15720.00	62.7 PK	74.0	-11.3	1.00 H	299	44.30	18.40
8	15720.00	50.5 AV	54.0	-3.5	1.00 H	299	32.10	18.40

**ANTENNA POLARITY & TEST DISTANCE: VERTICAL AT 3 M**

NO.	FREQ. (MHz)	EMISSION LEVEL (dBuV/m)	LIMIT (dBuV/m)	MARGIN (dB)	ANTENNA HEIGHT (m)	TABLE ANGLE (Degree)	RAW VALUE (dBuV)	CORRECTION FACTOR (dB/m)
1	*5240.00	116.2 PK			1.05 V	194	109.04	7.16
2	*5240.00	105.4 AV			1.05 V	194	98.24	7.16
3	5350.00	53.7 PK	74.0	-20.3	1.05 V	194	46.21	7.49
4	5350.00	42.3 AV	54.0	-11.7	1.05 V	194	34.81	7.49
5	#10480.00	60.8 PK	74.0	-13.2	1.01 V	26	47.64	13.16
6	#10480.00	46.4 AV	54.0	-7.6	1.01 V	26	33.24	13.16
7	15720.00	64.9 PK	74.0	-9.1	1.06 V	15	46.50	18.40
8	15720.00	51.8 AV	54.0	-2.2	1.06 V	15	33.40	18.40

**REMARKS:**

1. Emission Level(dBuV/m) = Raw Value(dBuV) + Correction Factor(dB/m)
2. Correction Factor(dB/m) = Antenna Factor(dB/m) + Cable Factor(dB) – Pre-Amplifier Factor(dB)
3. The other emission levels were very low against the limit.
4. Margin value = Emission Level – Limit value
5. " \* ": Fundamental frequency.
6. " # ": The radiated frequency is out of the restricted band.



A D T

802.11ac (VHT40)

<b>CHANNEL</b>	TX Channel 38	<b>DETECTOR FUNCTION</b>	Peak (PK)
<b>FREQUENCY RANGE</b>	1GHz ~ 40GHz		Average (AV)

**ANTENNA POLARITY & TEST DISTANCE: HORIZONTAL AT 3 M**

NO.	FREQ. (MHz)	EMISSION LEVEL (dBuV/m)	LIMIT (dBuV/m)	MARGIN (dB)	ANTENNA HEIGHT (m)	TABLE ANGLE (Degree)	RAW VALUE (dBuV)	CORRECTION FACTOR (dB/m)
1	5150.00	67.2 PK	74.0	-6.8	1.05 H	165	60.40	6.80
2	5150.00	49.9 AV	54.0	-4.1	1.05 H	165	43.10	6.80
3	*5190.00	98.3 PK			1.05 H	165	91.30	7.00
4	*5190.00	86.2 AV			1.05 H	165	79.20	7.00
5	#10380.00	61.5 PK	74.0	-12.5	1.21 H	70	48.33	13.17
6	#10380.00	47.3 AV	54.0	-6.7	1.21 H	70	34.13	13.17
7	15570.00	63.4 PK	74.0	-10.6	1.11 H	302	44.71	18.69
8	15570.00	51.4 AV	54.0	-2.6	1.11 H	302	32.71	18.69

**ANTENNA POLARITY & TEST DISTANCE: VERTICAL AT 3 M**

NO.	FREQ. (MHz)	EMISSION LEVEL (dBuV/m)	LIMIT (dBuV/m)	MARGIN (dB)	ANTENNA HEIGHT (m)	TABLE ANGLE (Degree)	RAW VALUE (dBuV)	CORRECTION FACTOR (dB/m)
1	5150.00	69.6 PK	74.0	-4.4	1.06 V	178	62.80	6.80
2	5150.00	53.1 AV	54.0	-0.9	1.06 V	178	46.30	6.80
3	*5190.00	109.6 PK			1.05 V	178	102.60	7.00
4	*5190.00	97.7 AV			1.05 V	178	90.70	7.00
5	#10380.00	60.3 PK	74.0	-13.7	1.09 V	7	47.13	13.17
6	#10380.00	45.1 AV	54.0	-8.9	1.09 V	7	31.93	13.17
7	15570.00	64.3 PK	74.0	-9.7	1.12 V	20	45.61	18.69
8	15570.00	51.2 AV	54.0	-2.8	1.12 V	20	32.51	18.69

**REMARKS:**

1. Emission Level(dBuV/m) = Raw Value(dBuV) + Correction Factor(dB/m)
2. Correction Factor(dB/m) = Antenna Factor(dB/m) + Cable Factor(dB) – Pre-Amplifier Factor(dB)
3. The other emission levels were very low against the limit.
4. Margin value = Emission Level – Limit value
5. " \* ": Fundamental frequency.
6. " # ": The radiated frequency is out of the restricted band.





A D T

<b>CHANNEL</b>	TX Channel 46	<b>DETECTOR FUNCTION</b>	Peak (PK)
<b>FREQUENCY RANGE</b>	1GHz ~ 40GHz		Average (AV)

**ANTENNA POLARITY & TEST DISTANCE: HORIZONTAL AT 3 M**

NO.	FREQ. (MHz)	EMISSION LEVEL (dBuV/m)	LIMIT (dBuV/m)	MARGIN (dB)	ANTENNA HEIGHT (m)	TABLE ANGLE (Degree)	RAW VALUE (dBuV)	CORRECTION FACTOR (dB/m)
1	5150.00	51.2 PK	74.0	-22.8	1.07 H	160	44.40	6.80
2	5150.00	41.3 AV	54.0	-12.7	1.07 H	160	34.50	6.80
3	*5230.00	99.2 PK			1.07 H	160	92.08	7.12
4	*5230.00	86.4 AV			1.07 H	160	79.28	7.12
5	5350.00	50.4 PK	74.0	-23.6	1.07 H	160	42.91	7.49
6	5350.00	43.5 AV	54.0	-10.5	1.07 H	160	36.01	7.49
7	#10460.00	62.5 PK	74.0	-11.5	1.21 H	78	49.32	13.18
8	#10460.00	48.3 AV	54.0	-5.7	1.21 H	78	35.12	13.18
9	15690.00	64.3 PK	74.0	-9.7	1.17 H	313	45.92	18.38
10	15690.00	52.0 AV	54.0	-2.0	1.17 H	313	33.62	18.38

**ANTENNA POLARITY & TEST DISTANCE: VERTICAL AT 3 M**

NO.	FREQ. (MHz)	EMISSION LEVEL (dBuV/m)	LIMIT (dBuV/m)	MARGIN (dB)	ANTENNA HEIGHT (m)	TABLE ANGLE (Degree)	RAW VALUE (dBuV)	CORRECTION FACTOR (dB/m)
1	5150.00	50.4 PK	74.0	-23.6	1.08 V	177	43.60	6.80
2	5150.00	43.2 AV	54.0	-10.8	1.08 V	177	36.40	6.80
3	*5230.00	110.2 PK			1.08 V	177	103.08	7.12
4	*5230.00	98.8 AV			1.08 V	177	91.68	7.12
5	5350.00	53.2 PK	74.0	-20.8	1.08 V	177	45.71	7.49
6	5350.00	45.2 AV	54.0	-8.8	1.08 V	177	37.71	7.49
7	#10460.00	60.8 PK	74.0	-13.2	1.00 V	9	47.62	13.18
8	#10460.00	46.2 AV	54.0	-7.8	1.00 V	9	33.02	13.18
9	15690.00	65.1 PK	74.0	-8.9	1.05 V	15	46.72	18.38
10	15690.00	51.7 AV	54.0	-2.3	1.05 V	15	33.32	18.38

**REMARKS:**

1. Emission Level(dBuV/m) = Raw Value(dBuV) + Correction Factor(dB/m)
2. Correction Factor(dB/m) = Antenna Factor(dB/m) + Cable Factor(dB) – Pre-Amplifier Factor(dB)
3. The other emission levels were very low against the limit.
4. Margin value = Emission Level – Limit value
5. " \* ": Fundamental frequency.
6. " # ": The radiated frequency is out of the restricted band.



A D T

802.11ac (VHT80)

<b>CHANNEL</b>	TX Channel 42	<b>DETECTOR FUNCTION</b>	Peak (PK)
<b>FREQUENCY RANGE</b>	1GHz ~ 40GHz		Average (AV)

**ANTENNA POLARITY & TEST DISTANCE: HORIZONTAL AT 3 M**

NO.	FREQ. (MHz)	EMISSION LEVEL (dBuV/m)	LIMIT (dBuV/m)	MARGIN (dB)	ANTENNA HEIGHT (m)	TABLE ANGLE (Degree)	RAW VALUE (dBuV)	CORRECTION FACTOR (dB/m)
1	5150.00	69.4 PK	74.0	-4.6	1.06 H	155	65.56	3.84
2	5150.00	51.3 AV	54.0	-2.7	1.06 H	155	47.46	3.84
3	*5210.00	94.3 PK			1.06 H	155	90.34	3.96
4	*5210.00	80.1 AV			1.06 H	155	76.14	3.96
5	5350.00	67.5 PK	74.0	-6.5	1.06 H	155	63.43	4.07
6	5350.00	49.6 AV	54.0	-4.4	1.06 H	155	45.53	4.07
7	#10420.00	62.3 PK	74.0	-11.7	1.25 H	87	52.80	9.50
8	#10420.00	46.5 AV	54.0	-7.5	1.25 H	87	37.00	9.50
9	15630.00	62.4 PK	74.0	-11.6	1.15 H	295	48.31	14.09
10	15630.00	50.4 AV	54.0	-3.6	1.15 H	295	36.31	14.09

**ANTENNA POLARITY & TEST DISTANCE: VERTICAL AT 3 M**

NO.	FREQ. (MHz)	EMISSION LEVEL (dBuV/m)	LIMIT (dBuV/m)	MARGIN (dB)	ANTENNA HEIGHT (m)	TABLE ANGLE (Degree)	RAW VALUE (dBuV)	CORRECTION FACTOR (dB/m)
1	5150.00	70.9 PK	74.0	-3.1	1.41 V	133	67.06	3.84
2	5150.00	53.3 AV	54.0	-0.7	1.41 V	133	49.46	3.84
3	*5210.00	106.6 PK			1.41 V	133	102.64	3.96
4	*5210.00	93.1 AV			1.41 V	133	89.14	3.96
5	5350.00	69.3 PK	74.0	-4.7	1.41 V	133	65.23	4.07
6	5350.00	51.4 AV	54.0	-2.6	1.41 V	133	47.33	4.07
7	#10420.00	60.4 PK	74.0	-13.6	1.05 V	14	50.90	9.50
8	#10420.00	45.0 AV	54.0	-9.0	1.05 V	14	35.50	9.50
9	15630.00	65.1 PK	74.0	-8.9	1.13 V	6	51.01	14.09
10	15630.00	51.8 AV	54.0	-2.2	1.13 V	6	37.71	14.09

**REMARKS:**

1. Emission Level(dBuV/m) = Raw Value(dBuV) + Correction Factor(dB/m)
2. Correction Factor(dB/m) = Antenna Factor(dB/m) + Cable Factor(dB) – Pre-Amplifier Factor(dB)
3. The other emission levels were very low against the limit.
4. Margin value = Emission Level – Limit value
5. " \* ": Fundamental frequency.
6. " # ": The radiated frequency is out of the restricted band.

### 4.3 TRANSMIT POWER MEASUREMENT

#### 4.3.1 LIMITS OF TRANSMIT POWER MEASUREMENT

Frequency Band	Limit
5.15 – 5.25GHz	The lesser of 50mW (17dBm) or 4dBm + 10logB
5.25 – 5.35GHz	The lesser of 250mW (24dBm) or 11dBm + 10logB
5.47 – 5.725GHz	The lesser of 250mW (24dBm) or 11dBm + 10logB
5.725 – 5.825GHz	The lesser of 1W (30dBm) or 17dBm + 10logB

**Note:** Where B is the 26dB emission bandwidth in MHz.

Per KDB 662911 D01 Multiple Transmitter Output Method of conducted output power measurement on IEEE 802.11 devices,

Array Gain = 0 dB (i.e., no array gain) for NANT ≤ 4;

Array Gain = 0 dB (i.e., no array gain) for channel widths ≥ 40 MHz for any NANT;

Array Gain = 5 log(NANT/NSS) dB or 3 dB, whichever is less for 20-MHz channel widths with NANT ≥ 5.

For power measurements on all other devices: Array Gain = 10 log(NANT/NSS) dB.



A D T

### 4.3.2 TEST INSTRUMENTS

#### FOR POWER OUTPUT MEASUREMENT

DESCRIPTION & MANUFACTURER	MODEL NO.	SERIAL NO.	CALIBRATED DATE	CALIBRATED UNTIL
Power meter Anritsu	ML2495A	1014008	Apr. 30, 2014	Apr. 29, 2015
Power sensor Anritsu	MA2411B	0917122	Apr. 30, 2014	Apr. 29, 2015

**Note:**

1. The calibration interval of the above test instruments is 12 months and the calibrations are traceable to NML/ROC and NIST/USA.
2. Tested date : Aug. 08, 2014

#### FOR 26dB OCCUPIED BANDWIDTH

DESCRIPTION & MANUFACTURER	MODEL NO.	SERIAL NO.	CALIBRATED DATE	CALIBRATED UNTIL
SPECTRUM ANALYZER R&S	FSV 40	100964	July 05, 2014	July 04, 2015

**Note:**

1. The calibration interval of the above test instruments is 12 months and the calibrations are traceable to NML/ROC and NIST/USA.
2. Tested date : Aug. 08, 2014

### 4.3.3 TEST PROCEDURE

#### FOR POWER OUTPUT MEASUREMENT

Method PM is used to perform output power measurement, trigger and gating function of wide band power meter is enabled to measure max output power of TX on burst. Duty factor is not added to measured value.

#### FOR 26dB OCCUPIED BANDWIDTH

1. Set RBW = approximately 1% of the emission bandwidth.
2. Set the VBW > RBW.
3. Detector = Peak.
4. Trace mode = max hold.
5. Measure the maximum width of the emission that is 26 dB down from the peak of the emission. Compare this with the RBW setting of the analyzer. Readjust RBW and repeat measurement as needed until the RBW/EBW ratio is approximately 1%.

### 4.3.4 DEVIATION FROM TEST STANDARD

No deviation

### 4.3.5 TEST SETUP

#### FOR POWER OUTPUT MEASUREMENT

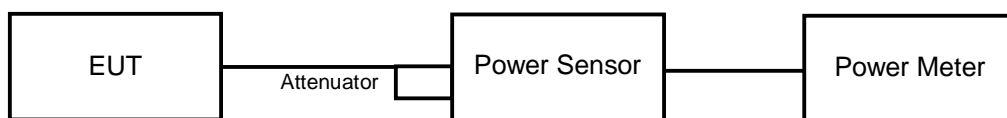

#### FOR 26dB OCCUPIED BANDWIDTH

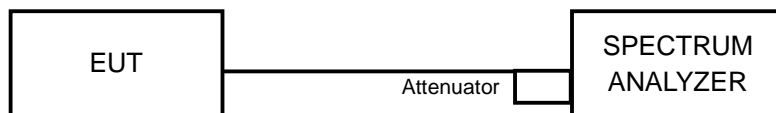

### 4.3.6 EUT OPERATING CONDITIONS

The software provided by client to enable the EUT under transmission condition continuously at specific channel frequencies individually.



A D T

### 4.3.7 TEST RESULTS

#### 802.11a

CHAN.	CHAN. FREQ. (MHz)	AVERAGE POWER (dBm)		TOTAL POWER (mW)	TOTAL POWER (dBm)	POWER LIMIT (dBm)	PASS / FAIL
		CHAIN 0	CHAIN 1				
36	5180	11.74	12.13	31.259	14.95	17	PASS
40	5200	11.71	12.19	31.383	14.97	17	PASS
48	5240	11.68	12.34	31.863	15.03	17	PASS

#### 26dB OCCUPIED BANDWIDTH:

CHANNEL	CHANNEL FREQUENCY (MHz)	26dBc BANDWIDTH (MHz)	
		CHAIN 0	CHAIN 1
36	5180	22.25	21.67
40	5200	21.12	22.37
48	5240	22.45	22.18

**Note: For output power limitation is determined based on 26dBc bandwidth.**

Power Limit = $4\text{dBm} + 10\log B < \text{UNII Band 1}>$			
Channel Number	Freq.(MHz)	Min. B(MHz)	Determined Conducted Limit (dBm)
36	5180	21.67	17.35 > 17
40	5200	21.12	17.24 > 17
48	5240	22.18	17.45 > 17



A D T

**802.11ac (VHT20)**

CHAN.	CHAN. FREQ. (MHz)	AVERAGE POWER (dBm)		TOTAL POWER (mW)	TOTAL POWER (dBm)	POWER LIMIT (dBm)	PASS / FAIL
		CHAIN 0	CHAIN 1				
36	5180	11.57	12.11	30.61	14.86	17	PASS
40	5200	11.46	12.17	30.478	14.84	17	PASS
48	5240	11.36	12.21	30.311	14.82	17	PASS

**26dB OCCUPIED BANDWIDTH:**

CHANNEL	CHANNEL FREQUENCY (MHz)	26dBc BANDWIDTH (MHz)	
		CHAIN 0	CHAIN 1
36	5180	22.88	23.17
40	5200	22.60	22.84
48	5240	22.42	22.92

**Note: For output power limitation is determined based on 26dBc bandwidth.**

Power Limit = 4dBm + 10logB < UNII Band 1 >			
Channel Number	Freq.(MHz)	Min. B(MHz)	Determined Conducted Limit (dBm)
36	5180	22.88	17.59 > 17
40	5200	22.60	17.54 > 17
48	5240	22.42	17.5 > 17



A D T

802.11ac (VHT40)

CHAN.	CHAN. FREQ. (MHz)	AVERAGE POWER (dBm)		TOTAL POWER (mW)	TOTAL POWER (dBm)	POWER LIMIT (dBm)	PASS / FAIL
		CHAIN 0	CHAIN 1				
38	5190	13.42	13.86	46.301	16.66	17	PASS
46	5230	13.48	13.92	46.944	16.72	17	PASS

26dB OCCUPIED BANDWIDTH:

CHANNEL	CHANNEL FREQUENCY (MHz)	26dBc BANDWIDTH (MHz)	
		CHAIN 0	CHAIN 1
38	5190	44.81	45.29
46	5230	45.75	46.60

Note: For output power limitation is determined based on 26dBc bandwidth.

Power Limit = 4dBm + 10logB < UNII Band 1 >			
Channel Number	Freq.(MHz)	Min. B(MHz)	Determined Conducted Limit (dBm)
38	5190	44.81	20.51 > 17
46	5230	45.75	20.6 > 17





A D T

802.11ac (VHT80)

CHAN.	CHAN. FREQ. (MHz)	AVERAGE POWER (dBm)		TOTAL POWER (mW)	TOTAL POWER (dBm)	POWER LIMIT (dBm)	PASS / FAIL
		CHAIN 0	CHAIN 1				
42	5210	13.23	13.68	44.373	16.47	17	PASS

26dB OCCUPIED BANDWIDTH:

CHANNEL	CHANNEL FREQUENCY (MHz)	26dBc BANDWIDTH (MHz)	
		CHAIN 0	CHAIN 1
42	5210	84.90	86.95

Note: For output power limitation is determined based on 26dBc bandwidth.

Power Limit = 4dBm + 10logB < UNII Band 1 >			
Channel Number	Freq.(MHz)	Min. B(MHz)	Determined Conducted Limit (dBm)
42	5210	84.90	23.28 > 17

#### 4.4 PEAK POWER SPECTRAL DENSITY MEASUREMENT

##### 4.4.1 LIMITS OF PEAK POWER SPECTRAL DENSITY MEASUREMENT

FREQUENCY BAND	LIMIT
5.15 ~ 5.25GHz	4dBm
5.25 ~ 5.35GHz	11dBm
5.47 – 5.725GHz	11dBm
5.725 ~ 5.825GHz	17dBm

##### 4.4.2 TEST INSTRUMENTS

DESCRIPTION & MANUFACTURER	MODEL NO.	SERIAL NO.	CALIBRATED DATE	CALIBRATED UNTIL
SPECTRUM ANALYZER R&S	FSV 40	100964	July 05, 2014	July 04, 2015

**Note:**

1. The calibration interval of the above test instruments is 12 months and the calibrations are traceable to NML/ROC and NIST/USA.
2. Tested date : Aug. 08, 2014

##### 4.4.3 TEST PROCEDURES

1. Set span to encompass the entire emission bandwidth (EBW) of the signal.
2. Set RBW = 1 MHz, Set VBW  $\geq$  3 MHz, Detector = RMS
3. Sweep time = auto, trigger set to “free run”.
4. Trace average at least 100 traces in power averaging mode.
5. Record the max value and for duty cycle of test signal is < 98% add 10 log (1/duty cycle)

##### 4.4.4 DEVIATION FROM TEST STANDARD

No deviation

#### 4.4.5 TEST SETUP

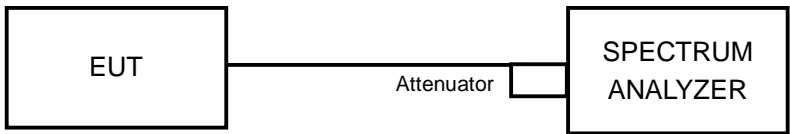

#### 4.4.6 EUT OPERATING CONDITIONS

Same as 4.3.6



A D T

#### 4.4.7 TEST RESULTS

##### 802.11a

CHANNEL	CHANNEL FREQUENCY (MHz)	PSD (dBm)		TOTAL POWER DENSITY (dBm)	MAX. LIMIT (dBm)	PASS/FAIL
		CHAIN 0	CHAIN 1			
36	5180	-1.30	-0.81	1.96	2.37	PASS
40	5200	-1.99	-0.46	1.85	2.37	PASS
48	5240	-1.14	-0.51	2.20	2.37	PASS

**NOTE:** 1. Method a) of power density measurement of KDB 662911 is using for calculating total power density. Total power density is summing entire spectra across corresponding frequency bins on the various outputs by computer.

2. Directional gain =  $10 \log[(10^{G1/20} + 10^{G2/20})^2 / 2] = 7.63\text{dBi} > 6\text{dBi}$  , so the power density limit shall be reduced to  $4-(7.63-6) = 2.37\text{dBm}$ .

##### 802.11ac (VHT20)

CHANNEL	CHANNEL FREQUENCY (MHz)	PSD (dBm)		TOTAL POWER DENSITY (dBm)	MAX. LIMIT (dBm)	PASS/FAIL
		CHAIN 0	CHAIN 1			
36	5180	-1.89	-0.96	1.61	2.37	PASS
40	5200	-1.41	-0.86	1.88	2.37	PASS
48	5240	-2.29	-0.60	1.65	2.37	PASS

**NOTE:** 1. Method a) of power density measurement of KDB 662911 is using for calculating total power density. Total power density is summing entire spectra across corresponding frequency bins on the various outputs by computer.

2. Directional gain =  $10 \log[(10^{G1/20} + 10^{G2/20})^2 / 2] = 7.63\text{dBi} > 6\text{dBi}$  , so the power density limit shall be reduced to  $4-(7.63-6) = 2.37\text{dBm}$ .



A D T

### 802.11ac (VHT40)

CHANNEL	CHANNEL FREQUENCY (MHz)	PSD W/O DUTY FACTOR (dBm)		DUTY FACTOR (dB)	TOTAL PSD WITH DUTY FACTOR (dBm)	MAX. LIMIT (dBm)	PASS / FAIL
		CHAIN 0	CHAIN 1				
38	5190	-2.92	-2.56	0.12	0.39	2.37	PASS
46	5230	-4.67	-2.77	0.12	-0.49	2.37	PASS

- NOTE:** 1. Method a) of power density measurement of KDB 662911 is using for calculating total power density. Total power density is summing entire spectra across corresponding frequency bins on the various outputs by computer.
2. Directional gain =  $10 \log[(10^{G1/20} + 10^{G2/20})^2 / 2] = 7.63\text{dBi} > 6\text{dBi}$  , so the power density limit shall be reduced to  $4-(7.63-6) = 2.37\text{dBm}$ .
3. Refer to section 3.4 for duty cycle spectrum plot.

### 802.11ac (VHT80)

CHANNEL	CHANNEL FREQUENCY (MHz)	PSD W/O DUTY FACTOR (dBm)		DUTY FACTOR (dB)	TOTAL PSD WITH DUTY FACTOR (dBm)	MAX. LIMIT (dBm)	PASS / FAIL
		CHAIN 0	CHAIN 1				
42	5210	-7.58	-6.70	0.23	-3.88	2.37	PASS

- NOTE:** 1. Method a) of power density measurement of KDB 662911 is using for calculating total power density. Total power density is summing entire spectra across corresponding frequency bins on the various outputs by computer.
2. Directional gain =  $10 \log[(10^{G1/20} + 10^{G2/20})^2 / 2] = 7.63\text{dBi} > 6\text{dBi}$  , so the power density limit shall be reduced to  $4-(7.63-6) = 2.37\text{dBm}$ .
3. Refer to section 3.4 for duty cycle spectrum plot.



A D T

### SPECTRUM PLOT OF WORST VALUE

#### 802.11a / Chain (1) : CH40

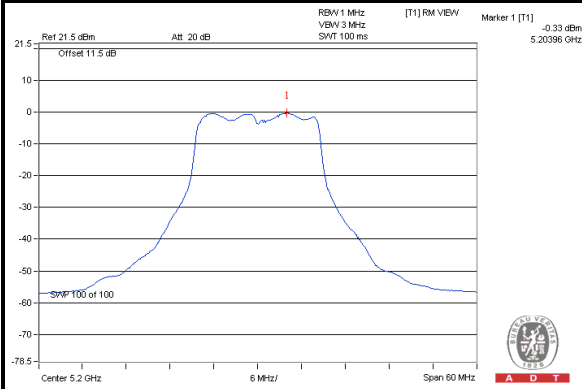

#### 802.11ac (VHT20) / Chain (1) : CH48

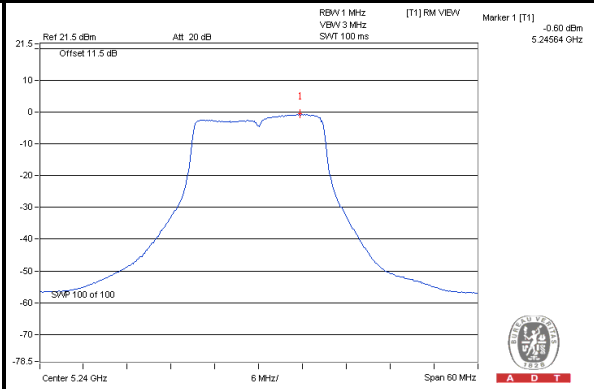

#### 802.11ac (VHT40) / Chain (1) : CH38

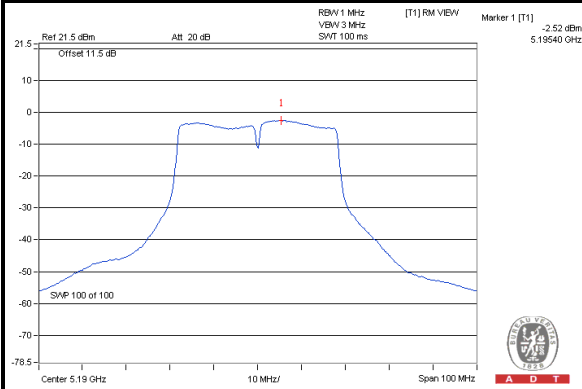

#### 802.11ac (VHT80) / Chain (1) : CH42

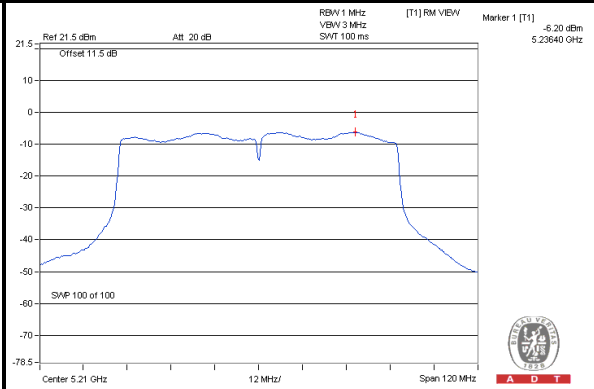

## 4.5 PEAK POWER EXCURSION MEASUREMENT

### 4.5.1 LIMITS OF PEAK POWER EXCURSION MEASUREMENT

Shall not exceed 13 dB

### 4.5.2 TEST INSTRUMENTS

DESCRIPTION & MANUFACTURER	MODEL NO.	SERIAL NO.	CALIBRATED DATE	CALIBRATED UNTIL
SPECTRUM ANALYZER R&S	FSV 40	100964	July 05, 2014	July 04, 2015

**Note:**

1. The calibration interval of the above test instruments is 12 months and the calibrations are traceable to NML/ROC and NIST/USA.
2. Tested date : Aug. 08, 2014

### 4.5.3 TEST PROCEDURE

1. Set RBW = 1 MHz, VBW  $\geq$  3 MHz, Detector = peak.
2. Trace mode = max-hold. Allow the sweeps to continue until the trace stabilizes.
3. Use the peak search function to find the peak of the spectrum.
4. Measure the PPSD.
5. Compute the ratio of the maximum of the peak-max-hold spectrum to the PPSD.

### 4.5.4 DEVIATION FROM TEST STANDARD

No deviation

### 4.5.5 TEST SETUP

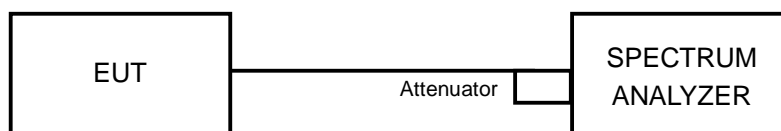

#### 4.5.6 EUT OPERATING CONDITIONS

The software provided by client to enable the EUT under transmission condition continuously at specific channel frequencies individually.





### 4.5.7 TEST RESULTS

**Without duty factor:**

MODULATION MODE	MODULATION TYPE	CHANNEL FREQUENCY (MHz)	PEAK VALUE (dBm)	PPSD (dBm)	PEAK EXCURSION (dB)	LIMIT (dB)	PASS/ FAIL
802.11a	BPSK	5240	8.30	-1.11	9.41	13	PASS
802.11ac (VHT20)	BPSK	5240	8.41	-0.73	9.14	13	PASS

**With duty factor:**

MODULATION MODE	MODULATION TYPE	CHAN. FREQ. (MHz)	PEAK VALUE (dBm)	PPSD WITHOUT DUTY FACTOR (dBm)	PPSD WITH DUTY FACTOR (dBm)	PEAK EXCURSION (dB)	LIMIT (dB)	PASS /FAIL
802.11a	QPSK	5240	9.02	-0.80	-0.69	9.71	13	PASS
	16QAM		9.87	-0.94	-0.34	10.21	13	PASS
	64QAM		8.39	-1.35	-0.97	9.36	13	PASS
802.11ac (VHT20)	QPSK	5240	8.62	-1.18	-1.05	9.67	13	PASS
	16QAM		9.11	-1.28	-1.06	10.17	13	PASS
	64QAM		8.74	-1.71	-1.29	10.03	13	PASS
	256QAM		9.55	-1.81	-1.22	10.77	13	PASS
802.11ac (VHT40)	BPSK	5230	6.13	-3.06	-2.94	9.07	13	PASS
	QPSK		5.36	-4.61	-3.96	9.32	13	PASS
	16QAM		5.79	-4.75	-4.26	10.05	13	PASS
	64QAM		6.79	-4.79	-3.99	10.78	13	PASS
	256QAM		5.87	-4.91	-3.97	9.84	13	PASS
802.11ac (VHT80)	BPSK	5210	5.18	-6.54	-6.31	11.49	13	PASS
	QPSK		3.78	-6.44	-5.88	9.66	13	PASS
	16QAM		4.92	-6.90	-6.08	11.00	13	PASS
	64QAM		5.23	-6.58	-5.15	10.38	13	PASS
	256QAM		4.35	-6.79	-4.97	9.32	13	PASS

**NOTE:** 1. Refer to section 3.4 for duty cycle spectrum plot.



A D T

### SPECTRUM PLOT OF WORST VALUE

#### 802.11a / 16QAM

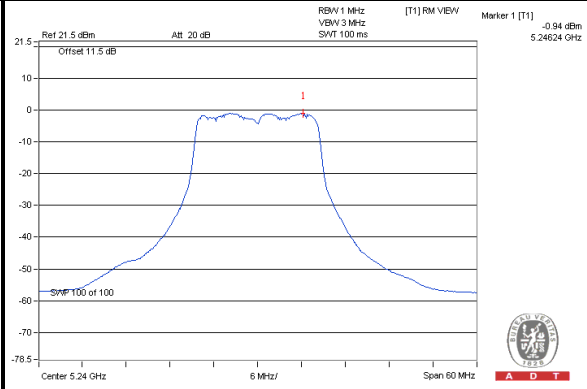
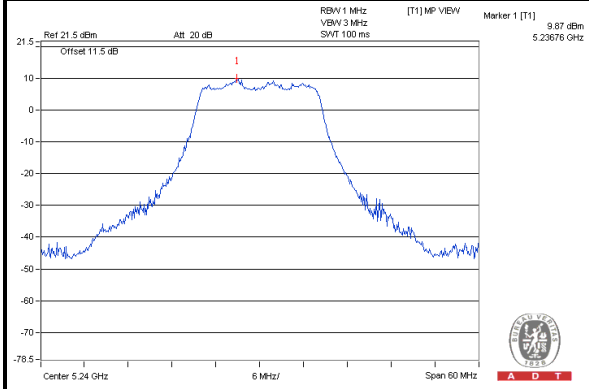

#### 802.11ac (VHT20) / 256QAM

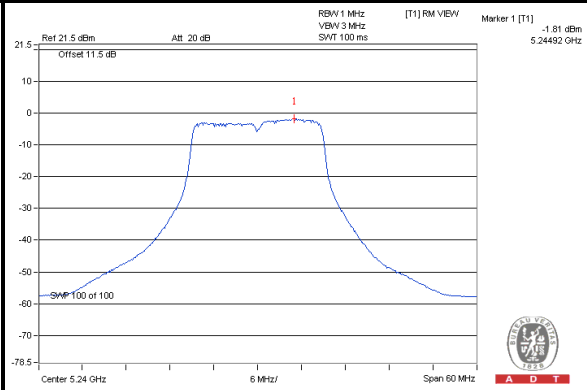
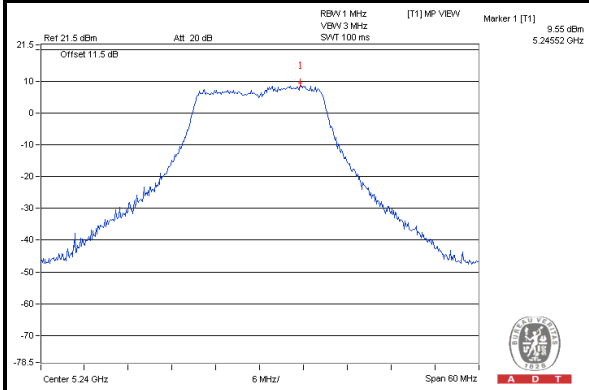

#### 802.11ac (VHT40) / 64QAM

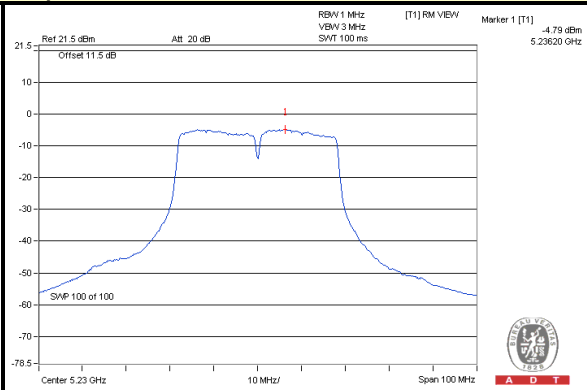
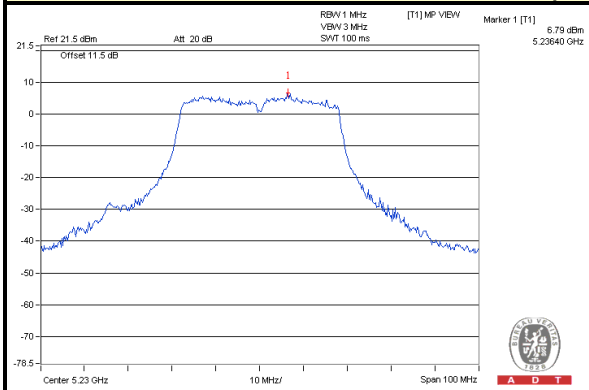



A D T

### 802.11ac (VHT80) / BPSK

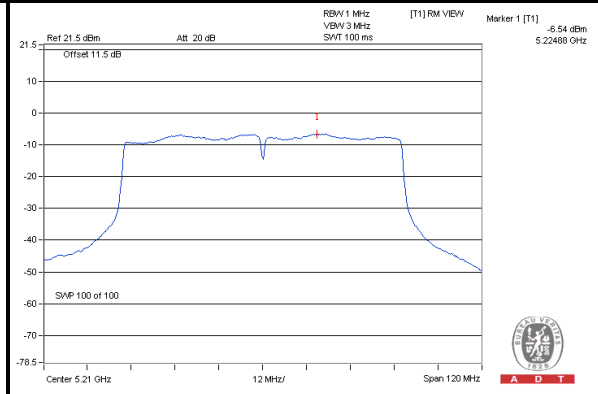
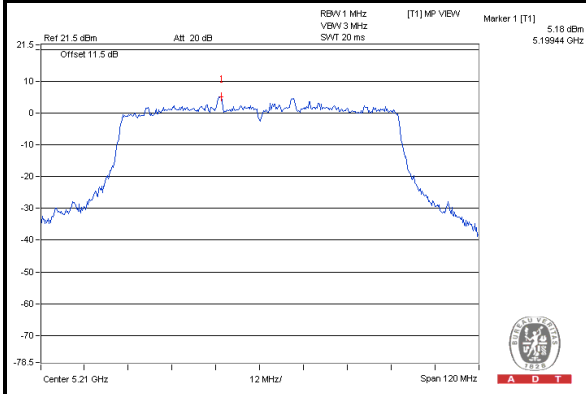



A D T

## 4.6 FREQUENCY STABILITY

### 4.6.1 LIMITS OF FREQUENCY STABILITY MEASUREMENT

The frequency of the carrier signal shall be maintained within band of operation

### 4.6.2 TEST INSTRUMENTS

DESCRIPTION & MANUFACTURER	MODEL NO.	SERIAL NO.	CALIBRATED DATE	CALIBRATED UNTIL
SPECTRUM ANALYZER R&S	FSV 40	100964	July 05, 2014	July 04, 2015
Temperature Humidity Chamber GIANTFORCE &	GTH-150-40-SP -AR	MAA0812-008	Jan. 13, 2014	Jan. 12, 2015

**Note:**

1. The calibration interval of the above test instruments is 12 months and the calibrations are traceable to NML/ROC and NIST/USA.
2. Tested date : Aug. 08, 2014

### 4.6.3 TEST PROCEDURE

1. The EUT was placed inside the environmental test chamber and powered by nominal AC voltage.
2. Turn the EUT on and couple its output to a spectrum analyzer.
3. Turn the EUT off and set the chamber to the highest temperature specified.
4. Allow sufficient time (approximately 30 min) for the temperature of the chamber to stabilize, turn the EUT on and measure the operating frequency after 2, 5, and 10 minutes.
5. Repeat step 2 and 3 with the temperature chamber set to the lowest temperature.
6. The test chamber was allowed to stabilize at +20 degree C for a minimum of 30 minutes. The supply voltage was then adjusted on the EUT from 85% to 115% and the frequency record.

#### 4.6.4 DEVIATION FROM TEST STANDARD

No deviation

#### 4.6.5 TEST SETUP

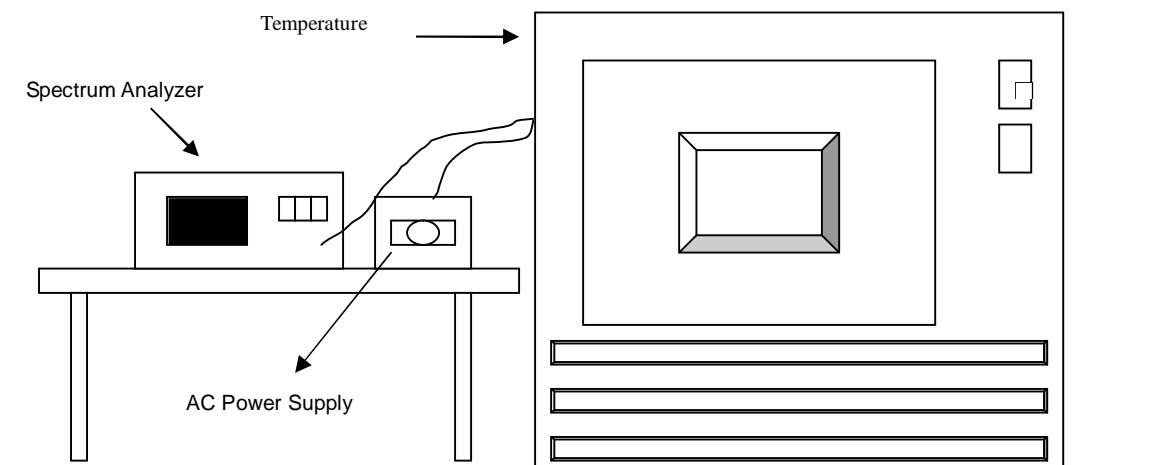

#### 4.6.6 EUT OPERATING CONDITION

Set the EUT transmit at un-modulation mode to test frequency stability.



A D T

### 4.6.7 TEST RESULTS

FREQUENCY STABILITY VERSUS TEMP.									
OPERATING FREQUENCY: 5240MHz									
TEMP. (°C)	POWER SUPPLY (Vac)	0 MINUTE		2 MINUTE		5 MINUTE		10 MINUTE	
		Measured Frequency	Frequency Drift	Measured Frequency	Frequency Drift	Measured Frequency	Frequency Drift	Measured Frequency	Frequency Drift
		(MHz)	%	(MHz)	%	(MHz)	%	(MHz)	%
50	120	5240.0217	0.00041	5240.0185	0.00035	5240.0182	0.00035	5240.021	0.00040
40	120	5239.9752	-0.00047	5239.978	-0.00042	5239.9776	-0.00043	5239.9753	-0.00047
30	120	5239.9783	-0.00041	5239.9756	-0.00047	5239.9761	-0.00046	5239.9777	-0.00043
20	120	5239.9928	-0.00014	5239.9951	-0.00009	5239.9918	-0.00016	5239.9931	-0.00013
10	120	5239.9883	-0.00022	5239.9874	-0.00024	5239.9883	-0.00022	5239.9896	-0.00020
0	120	5240.0079	0.00015	5240.0053	0.00010	5240.0075	0.00014	5240.0069	0.00013
-10	120	5240.0163	0.00031	5240.0151	0.00029	5240.0183	0.00035	5240.0159	0.00030
-20	120	5240.0198	0.00038	5240.0218	0.00042	5240.0229	0.00044	5240.0215	0.00041
-30	120	5239.9851	-0.00028	5239.9864	-0.00026	5239.9859	-0.00027	5239.9865	-0.00026

FREQUENCY STABILITY VERSUS VOLTAGE									
OPERATING FREQUENCY: 5240MHz									
TEMP. (°C)	POWER SUPPLY (Vac)	0 MINUTE		2 MINUTE		5 MINUTE		10 MINUTE	
		Measured Frequency	Frequency Drift	Measured Frequency	Frequency Drift	Measured Frequency	Frequency Drift	Measured Frequency	Frequency Drift
		(MHz)	%	(MHz)	%	(MHz)	%	(MHz)	%
20	138	5239.9918	-0.00016	5239.9961	-0.00007	5239.9916	-0.00016	5239.993	-0.00013
	120	5239.9928	-0.00014	5239.9951	-0.00009	5239.9918	-0.00016	5239.9931	-0.00013
	102	5239.9929	-0.00014	5239.9951	-0.00009	5239.9916	-0.00016	5239.9935	-0.00012



A D T

## 5. PHOTOGRAPHS OF THE TEST CONFIGURATION

Please refer to the attached file (Test Setup Photo).



## 6. INFORMATION ON THE TESTING LABORATORIES

We, Bureau Veritas Consumer Products Services (H.K.) Ltd., Taoyuan Branch, were founded in 1988 to provide our best service in EMC, Radio, Telecom and Safety consultation. Our laboratories are accredited and approved according to ISO/IEC 17025.

If you have any comments, please feel free to contact us at the following:

**Linko EMC/RF Lab:**

Tel: 886-2-26052180

Fax: 886-2-26052943

**Hsin Chu EMC/RF Lab:**

Tel: 886-3-5935343

Fax: 886-3-5935342

**Hwa Ya EMC/RF/Safety/Telecom Lab:**

Tel: 886-3-3183232

Fax: 886-3-3270892

**Email:** [service.adt@tw.bureauveritas.com](mailto:service.adt@tw.bureauveritas.com)

**Web Site:** [www.bureauveritas-adt.com](http://www.bureauveritas-adt.com)

The address and road map of all our labs can be found in our web site also.





A D T

## **7. APPENDIX A - MODIFICATIONS RECORDERS FOR ENGINEERING CHANGES TO THE EUT BY THE LAB**

No modifications were made to the EUT by the lab during the test.

**--- END ---**