

MATRIX

3x
5x

7xi
7xe





CONSOLE GUIDE



SERIAL NUMBER LOCATIONS

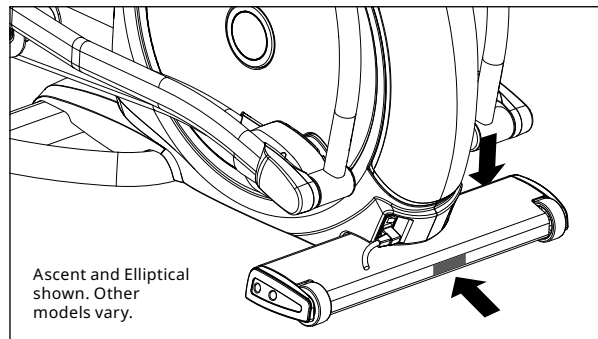
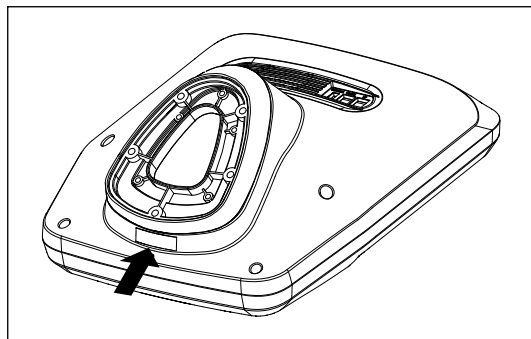

Before proceeding, find the serial numbers located on barcode stickers and enter them in the spaces provided below.

CONSOLE SERIAL NUMBER

FRAME SERIAL NUMBER

MODEL

<input type="checkbox"/> A3x	<input type="checkbox"/> A5x	<input type="checkbox"/> A7xe	<input type="checkbox"/> A7xi	MATRIX ASCENT TRAINER
<input type="checkbox"/> E3x	<input type="checkbox"/> E5x	<input type="checkbox"/> E7xe	<input type="checkbox"/> E7xi	MATRIX SUSPENSION ELLIPTICAL TRAINER
<input type="checkbox"/> ALB3x	<input type="checkbox"/> ALB5x	<input type="checkbox"/> ALB7xe	<input type="checkbox"/> ALB7xi	MATRIX ASCENT TRAINER LOWER BODY
<input type="checkbox"/> H3x	<input type="checkbox"/> H5x	<input type="checkbox"/> H7xe	<input type="checkbox"/> H7xi	MATRIX HYBRID CYCLE
<input type="checkbox"/> R3x	<input type="checkbox"/> R5x	<input type="checkbox"/> R7xe	<input type="checkbox"/> R7xi	MATRIX RECUMBENT CYCLE
<input type="checkbox"/> U3x	<input type="checkbox"/> U5x	<input type="checkbox"/> U7xe	<input type="checkbox"/> U7xi	MATRIX UPRIGHT CYCLE
<input type="checkbox"/> C3x	<input type="checkbox"/> C5x	<input type="checkbox"/> C7xe	<input type="checkbox"/> C7xi	MATRIX CLIMBMILL
<input type="checkbox"/> S3x	<input type="checkbox"/> S5x	<input type="checkbox"/> S7xe	<input type="checkbox"/> S7xi	MATRIX STEPPER

* Use the information above when calling for service.



3X

A3X CONSOLE SHOWN

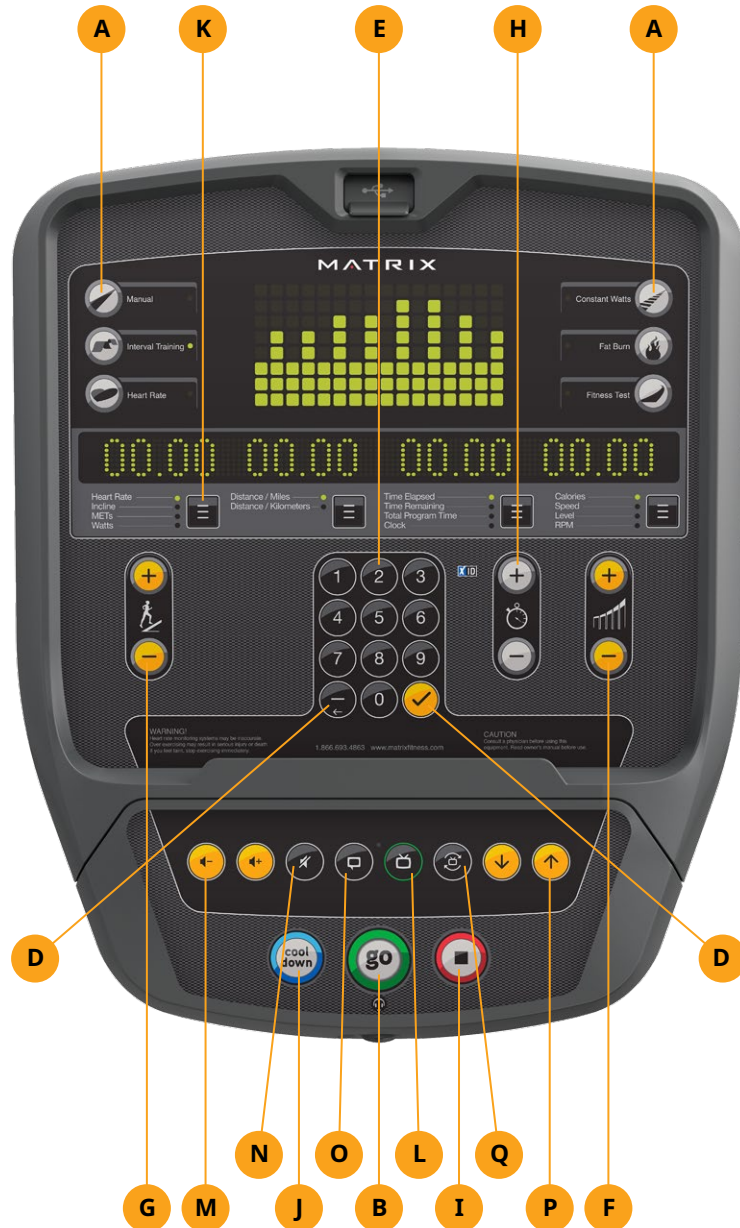

3X CONSOLE DESCRIPTION

The Matrix machine is inspected before it is packaged. It is shipped in two pieces: the base and the console. Carefully unpack the unit and dispose of the box material. Note: There is a thin protective sheet of clear plastic on the overlay of the console that should be removed before use.

- A) **WORKOUT KEYS:** Simple program view and selection buttons.
- B) **GO:** One Touch Start.
- C) **ENTER ✓:** Confirm each program setting.
- D) **BACK:** Go to previous program setting.
- E) **NUMBER KEYPAD:** Enter program settings.
- F) **UP/DOWN LEVEL:** Adjust resistance level.
- G) **UP/DOWN INCLINE (A3X ONLY):** Adjust incline level.
- H) **UP/DOWN TIME:** Adjust workout time.
- I) **STOP:** Ends workout and shows workout summary data.
- J) **COOL DOWN:** Puts the console into Cool Down mode.
- K) **TOGGLE DISPLAY:** Cycles between 3 or 4 rows of workout information displayed in LED window. The console will automatically cycle between the workout information if the Toggle Display button is pushed and held down for 3 seconds.

ENTERTAINMENT BUTTONS

- L) **TV POWER:** Turns connected TV on or off.
- M) **VOLUME UP/DOWN:** Adjusts the volume output through headphones.
- N) **MUTE:** Mutes sound.
- O) **CC:** Turns closed captioning on or off.
- P) **CHANNEL UP/DOWN:** Change channels on the integrated console TV.
- Q) **LAST CHANNEL:** Cycle between the current channel and the previous channel.
- E) **NUMBER KEYPAD:** Enter channel number. Press ✓ to confirm channel number.

AS5X CONSOLE SHOWN



5X CONSOLE DESCRIPTION

The Matrix machine is inspected before it is packaged. It is shipped in two pieces: the base and the console. Carefully unpack the unit and dispose of the box material. Note: There is a thin protective sheet of clear plastic on the overlay of the console that should be removed before use.

- A) WORKOUT KEYS:** Simple program view and selection buttons.
- B) GO:** One Touch Start.
- C) ENTER:** To confirm each program setting.
- D) UP/DOWN INCLINE (A5X ONLY):** Easy information and incline selection.
- E) UP/DOWN LEVEL:** Easy information and level selection.
- F) UP/DOWN TIME:** Easy information and time adjustment.
- G) STOP:** Ends workout and shows workout summary data.
- H) TOGGLE DISPLAY:** Cycles between 2 or 4 rows of workout information displayed in LED window. The console will automatically cycle between the workout information if the Toggle Display button is pushed and held down for 3 seconds.
- I) NUMBER KEYPAD:** Workout data input for workout setup. Level adjustment during workout.
- J) COOL DOWN:** Puts the Ascent into Cool Down mode.
- K) LANGUAGE:** Select Language.
- L) FAN:** Allows for fan speed selection (fan has three operating speeds).
- M) RFID SENSOR:** Wireless login access location (optional add-on feature).

5X ENTERTAINMENT ZONE

- N) HOME:** No function on this model.
- O) LAST CHANNEL:** Allows the user to cycle between the current channel and the previous channel they were viewing.
- P) CC:** Turns closed captioning on or off.
- Q) MUTE:** Mutes sound.
- R) VOLUME UP/DOWN:** Adjusts the volume output through headphones.
- S) NUMBER KEYPAD:** Allows for easy number inputs.
- T) CHANNEL UP/DOWN:** Allows for channel selection on the integrated console TV.
- U) TV POWER:** Turns external TV on or off.



5X



7XE

A7XE CONSOLE SHOWN



7XE CONSOLE DESCRIPTION

The Matrix machine is inspected before it is packaged. It is shipped in two pieces: the base and the console. Carefully unpack the unit and dispose of the box material. Note: There is a thin protective sheet of clear plastic on the overlay of the console that should be removed before use.

The 7xe has a fully integrated touch screen display. All information required for workouts is explained on screen. Exploration of the interface is highly encouraged. The information explaining how to program for various workouts will give an explanation about the contents of each screen on the 7xe.

- A) **GO:** One Touch Start.
- B) **STOP** (displayed on-screen during workout): Ends workout and shows workout summary data.
- C) **COOL DOWN** (displayed on-screen during workout): Puts unit into Cool Down mode. Cool Down time is dependent on the workout.

7XE ENTERTAINMENT ZONE

- D) **VOLUME UP/DOWN:** Adjusts the volume output through headphones.
- E) **CHANNEL UP/DOWN:** Allows for channel selection on the integrated console TV.
- F) **HOME:** Will take the user back to the home screen.
- G) **LAST CHANNEL:** Allows the user to cycle between the current channel and the previous channel they were viewing.
- H) **CC/MUTE:** Mutes sound and turns closed captioning on or off.
- I) **DISPLAY MODE:** Allows user to cycle through display modes.
- J) **NUMBER KEYPAD:** Allows for easy number inputs.
- K) **RFID SENSOR:** Wireless login access location (optional add-on feature).

A7XI CONSOLE SHOWN



7XI CONSOLE DESCRIPTION

The Matrix machine is inspected before it is packaged. It is shipped in two pieces: the base and the console. Carefully unpack the unit and dispose of the box material. Note: There is a thin protective sheet of clear plastic on the overlay of the console that should be removed before use.

The 7xi has a fully integrated touch screen display. All information required for workouts is explained on screen. Exploration of the interface is highly encouraged. The information explaining how to program for various workouts will give an explanation about the contents of each screen on the 7xi.

- A) **GO:** One Touch Start.
- B) **STOP** (displayed on-screen during workout): Ends workout and shows workout summary data.
- C) **COOL DOWN** (displayed on-screen during workout): Puts unit into Cool Down mode. Cool Down time is dependent on the workout.

7XI ENTERTAINMENT ZONE

- D) **VOLUME UP/DOWN:** Adjusts the volume output through headphones.
- E) **CHANNEL UP/DOWN:** Allows for channel selection on the integrated console TV.
- F) **HOME:** Will take the user back to the home screen.
- G) **LAST CHANNEL:** Allows the user to cycle between the current channel and the previous channel they were viewing.
- H) **CC/MUTE:** Mutes sound and turns closed captioning on or off.
- I) **DISPLAY MODE:** Allows user to cycle through display modes.
- J) **NUMBER KEYPAD:** Allows for easy number inputs.
- K) **RFID SENSOR:** Wireless login access location (optional add-on feature).



7XI





7XE
7XI

7XE / 7XI CONSOLE OPERATION

GETTING STARTED

- Touch the **USER** button to sign-in with your XID.
- Touch the **GUEST** button to workout anonymously.
- Touch the **REGISTER** button to create a new XID.
- For help or more information, touch **i**.
- To change language, touch .

USER SIGN-IN *

- 1) Enter your **XID** and touch .
- 2) Enter your **PASSCODE** and touch .



Consoles equipped with RFID will have this symbol in the lower-right corner of the display. To log in, touch your RFID tag to the symbol  located on the bottom right of the console.

REGISTER A NEW USER

- 1) Don't have an xID account? Registration is easy.
- 2) Follow the on-screen prompts to create your free account.
- 3) Review your information and select the **I ACCEPT THE TERMS AND CONDITIONS** box to review the Terms and Conditions.
- 4) Touch  to complete registration. Your account is now active and you are signed-in.

LOGIN SCREEN

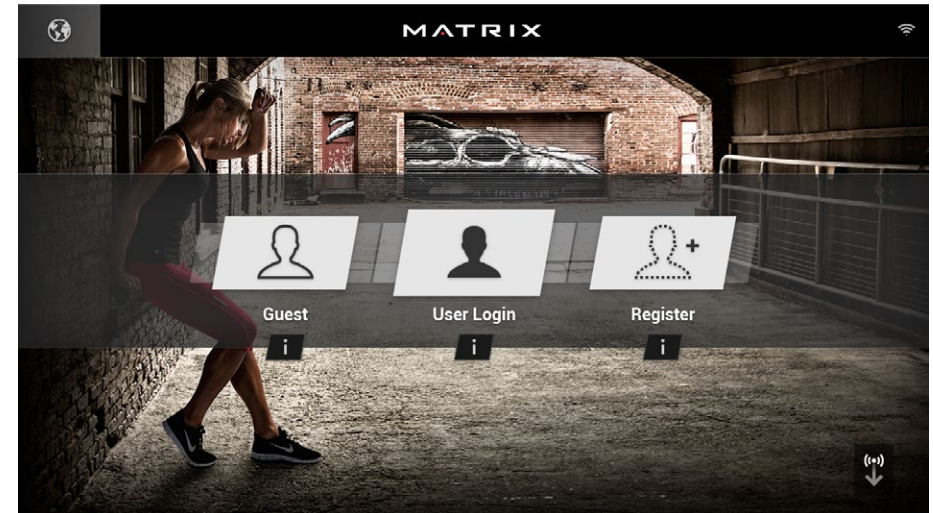

GO SCREEN

- Touch **GO** to begin working out immediately. Or...
- Touch the **WORKOUT CATEGORY** button of your choice to customize your workout.

PROGRAM SETUP

- 1) After selecting a **WORKOUT CATEGORY** button, select one of the **PROGRAMS** listed to the left.
For more information on a selected program, touch .
- 2) Use the **SLIDER CONTROLS** to adjust your program settings.
- 3) Press **GO** to begin your workout.

GO SCREEN



PROGRAM SETUP

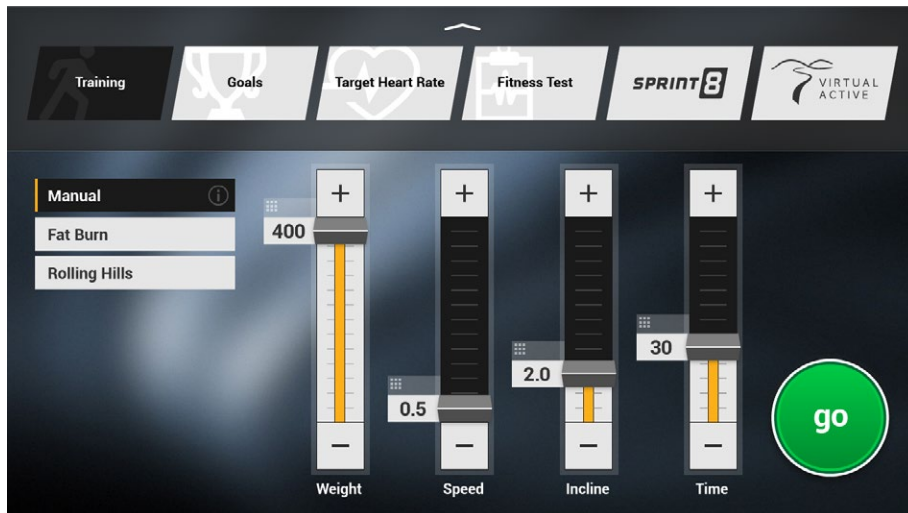

* Workouts and features vary based on model type, console configurations, software versions and options purchased.

HOMESCREEN



HOMESCREEN

- The **USERNAME** or **GUEST** is shown in the upper left corner.
- Touch **≡** to change **WORKOUT STATISTICS** displayed at the bottom of the screen.
- Touch **↑** to go back to the home screen whenever you're using an app.
- Touch **⚙** to adjust **VOLUME**, pair a **BLUETOOTH** device or to change **AUDIO SOURCE** (TV, My Media, Virtual Active, etc.).
- Touch **↓**/**↑** to increase or decrease the intensity level, speed or incline.
- Touch **⌨** to use the keypad to set intensity level, speed or incline. Press **⏹** to confirm change.
- Touch **↶** to change intensity level, speed or incline back to previous setting.
- Touch **⏸** to temporarily pause your workout and touch **▶** to resume. NOTE: After resuming, speed, incline and intensity levels will be reset.
- While paused, touch **■** to end workout.
- Touch **−**/**+** to increase or decrease the duration of your workout.
- Touch **📉** to enter cool down mode. Cool down lasts for a few minutes while reducing the workout intensity, allowing your body to recover from your workout.
- Touch **🔒** to lock the screen in order to prevent accidental screen touches from being implemented. Touch it again to unlock the screen and allow screen touches.
- Touch **🌀** to turn the fan on. There are three fan speeds (low, medium, high).



7XE
7XI



7XE
7XI

APPS AND ENTERTAINMENT



SIMPLE

Workout stats are displayed in 3 customizable windows.



TRACK

Displays a 400 M (1/4 MILE) track. Split feature allows you to keep track of your fastest laps and improve your time.



VIRTUAL ACTIVE

Your workout info is displayed and Virtual Active courses are shown. With Virtual Active, escape the confines of an ordinary workout as you or walk or run through exotic destinations.



TARGET HEART RATE

Track your progress while working out to a Target Heart Rate program.



CONSTANT WATTS

Track your progress while working out to a Constant Watts program.



FITNESS TEST

Track your progress while working out to a Fitness Test program.



LANDMARKS

Track your progress while working out to a Landmarks program.



SPRINT 8

Track your progress while working out to a Sprint 8 program.



CHANGE WORKOUT

Select a different workout without stopping your current workout.



MY MEDIA

Connect and control audio and video files on-screen via USB port or Bluetooth.



TV

Watch live TV.



WEATHER

Get local weather info.



WEB BROWSER

Access the world wide web while you work out.



FACILITY CALENDAR

View Facility event schedule and other info.



YOUTUBE

Browse and watch YouTube videos while you work out.



FACEBOOK

Browse your Facebook page while you work out.



TWITTER

Access your Twitter feed while you work out.



NETFLIX

Browse and watch Netflix videos while you work out. Netflix account required to access content.



HULU PLUS

Browse and watch Hulu Plus videos while you work out. Hulu Plus account required to access content.



VEVO

Browse and watch Vevo videos while you work out. Vevo account required to access content.



VUDU

Browse and watch Vudu videos while you work out. Vudu account required to access content.



MYFITNESS PAL

Lose weight with MyFitnessPal, the fastest and easiest to use calorie counter.

* Availability of apps is subject to change. Additional apps may become available. Workouts and features vary based on model type, console configurations, software versions and options purchased.

This equipment has been tested and found to comply with the limits for a Class B digital device, pursuant to part 15 of the FCC rules. These limits are designed to provide reasonable protection against harmful interference in a residential installation. This equipment generates, uses and can radiate radio frequency energy and, if not installed and used in accordance with the instructions, may cause harmful interference to radio communications. However, there is no guarantee that interference will not occur in a particular installation. If this equipment does cause harmful interference to radio or television reception, which can be determined by turning the equipment off and on, the user is encouraged to try to correct the interference by one or more of the following measures:

- Reorient or relocate the receiving antenna.
- Increase the separation between the equipment and receiver.
- Connect the equipment into an outlet on a circuit different from that to which the receiver is connected.
- Consult the dealer or an experienced radio/TV technician for help.

Any changes or modifications not expressly approved by the party responsible for compliance could void the user's authority to operate this equipment.

FCC RF Radiation Exposure Statement:

1. This Transmitter must not be co-located or operating in conjunction with any other antenna or transmitter.
2. This equipment complies with FCC RF radiation exposure limits set forth for an uncontrolled environment.

This equipment should be installed and operated with a minimum distance of 20 centimeters between the radiator and your body

注意！

依據 低功率電波輻射性電機管理辦法

第十二條

經型式認證合格之低功率射頻電機，非經許可，公司、商號或使用者均不得擅自變更頻率、加大功率或變更原設計之特性及功能。

第十四條

低功率射頻電機之使用不得影響飛航安全及干擾合法通信；經發現有干擾現象時，應立即停用，並改善至無干擾時方得繼續使用。

前項合法通信，指依電信法規定作業之無線電通信。

低功率射頻電機須忍受合法通信或工業、科學及醫療用電波輻射性電機設備之干擾。

MATRIX