

EMC TEST REPORT

Report No. : 180400033TWN-001
Model No. : HURESAC-3XE-C
Issued Date : Apr. 09, 2018

Applicant: Johnson Health Tech. Co., Ltd.
No. 999, Sec. 2, Dongda Rd., Daya Dist., Taichung City 428,
Taiwan

Test Method/ Standard: 47 CFR FCC Part 15.247 & ANSI C63.10 2013
558074 D01 DTS Meas Guidance v04

Test Site: 960839

Test By: Intertek Testing Services Taiwan Ltd.
Hsinchu Laboratory
No. 11, Lane 275, Ko-Nan 1 Street, Chia-Tung Li,
Shiang-Shan District, Hsinchu City, Taiwan

It may be duplicated completely for legal use with the allowance of the applicant. It shall not be reproduced except in full, without the written approval of Intertek Laboratory. The test result(s) in this report only applies to the tested sample(s).

The test report was prepared by:

Candy Liu/ Assistant

These measurements were taken by:

Wayne Chen/ Engineer

The test report was reviewed by:

Name Rico Deng
Title Supervisor

Revision History

Report No.	Issue Date	Revision Summary
180400033TWN-001	Apr. 09, 2018	Add NFC module only. After engineer judgment, the difference does not affect original the RF characteristic, PCB layout and antenna location. Then the all test data and test items in this report based on report of 160300216TWN-001.

Table of Contents

1. Summary of Test Data	4
2. General Information.....	5
3. Minimum 6 dB Bandwidth	8
4. Maximum Peak Conducted Output Power	12
5. Power Spectral Density	14
6. Emissions In Non-Restricted Frequency Bands.....	18
7. Emissions In Restricted Frequency Bands (Radiated emission measurements).....	23
8. Emission On Band Edge.....	33
9. AC Power Line Conducted Emission.....	38
Appendix A: Test equipment list	42
Appendix B: Measurement Uncertainty	44

1. Summary of Test Data

Test Requirement	Applicable Rule (Section 15.247)	Result
Minimum 6 dB Bandwidth	15.247(a)(2) 558074 D01 DTS Meas Guidance v04	Pass
Maximum Peak Conducted Output Power	15.247(b)(3) 558074 D01 DTS Meas Guidance v04	Pass
Power Spectral Density	15.247(e)	Pass
Emissions In Non-Restricted Frequency Bands	15.247(d)	Pass
Emissions In Restricted Frequency Bands (Radiated emission measurements)	15.247(d), 15.205, 15.209	Pass
Emission On The Band Edge	15.247(d), 15.205	Pass
AC Power Line Conducted Emission	15.207	Pass
Antenna Requirement	15.203	Pass

2. General Information

2.1 Identification of the EUT

Product:	Console for Exercise Machine
Model No:	HURESAC-3XE-C
Radio Module:	WLT2564M
Brand Name:	Matrix Fitness
Operating Frequency:	2402 MHz ~ 2480 MHz
Channel Number:	40 channels
Frequency of Each Channel:	2402+2 k MHz, k=0~39
Access scheme:	GFSK
Rated Power:	DC 12 from adapter
Power Cord:	N/A
Sample Received:	Mar. 09, 2016
Sample condition:	Workable
Test Date(s):	Apr. 12, 2016 ~ Jun. 13, 2016

Note 1: The test report only allows to be revised within three years from its original issued date unless further standard or the requirement was noticed.

Note 2: When determining the test conclusion, the Measurement Uncertainty of test has been considered.

Note 3: Except where explicitly agreed in writing, all work and services performed by Intertek is subject to our standard Terms and Conditions which can be obtained at our website: <http://www.intertek-twn.com/terms/>. Intertek's responsibility and liability are limited to the terms and conditions of the agreement.

This report is made solely on the basis of your instructions and / or information and materials supplied by you and provide no warranty on the tested sample(s) be truly representative of the sample source. The report is not intended to be a recommendation for any particular course of action, you are responsible for acting as you see fit on the basis of the report results. Intertek is under no obligation to refer to or report upon any facts or circumstances which are outside the specific instructions received and accepts no responsibility to any parties whatsoever, following the issue of the report, for any matters arising outside the agreed scope of the works. This report does not discharge or release you from your legal obligations and duties to any other person. You are the only one authorized to permit copying or distribution of this report (and then only in its entirety). Any such third parties to whom this report may be circulated rely on the content of the report solely at their own risk.

2.2 Description of EUT

Modulation mode	Transmit path
	Chain 0 / Main
BT4.0	V

Product SW version : UI 0.1.7.2, OS 2.0.19, IO 10
 Product HW version : v1.1
 Radio SW version : WLT2564M AVRCP 1.6
 Radio HW version : 4.00&4_0_1_7
 Test SW Version : V2.0

2.3 Antenna description

The EUT uses a permanently connected antenna.

Antenna Gain : 2.5 dBi
 Antenna Type : Chip antenna
 Connector Type : Fixed

2.4 Peripherals equipment

Peripherals	Brand	Model No.	Serial No.	Data cable
Notebook PC	HP	HP Compaq nc2400	CNF6413CGN	RS232 0.5 meter × 1
Adapter	N/A	LSE0107A1240	N/A	N/A

2.5 Operation mode

The EUT was supplied with DC 12V from adapter
 TX mode based on “HCITester” to execute, and select different frequency and modulation.

2.6 Applied test modes and channels

Test items	Mode	Channel	Antenna
Minimum 6 dB Bandwidth	BT 4.0	Low , Middle , High	Chain0
Maximum peak conducted output power	BT 4.0	Low , Middle , High	Chain0
Power Spectral Density	BT 4.0	Low , Middle , High	Chain0
RF Antenna Conducted Spurious	BT 4.0	Low , Middle , High	Chain0
Radiated Spurious Emission 30MHz~1GHz	BT 4.0	Low	Chain0
Radiated Spurious Emission 1GHz~10th Harmonic	BT 4.0	Low , Middle , High	Chain0
Emission on the Band Edge	BT 4.0	Low , High	Chain0
AC Power Line Conducted Emission	BT 4.0	Low	Chain0

3. Minimum 6 dB Bandwidth

3.1 Operating environment

Temperature:	21	°C
Relative Humidity:	55	%
Atmospheric Pressure	1008	hPa
Requirement & Test method	15.247(a)(2) 558074 D01 DTS Meas Guidance v04	

3.2 Limit for minimum 6dB bandwidth

The minimum 6 dB bandwidth shall be at least 500 kHz.

3.3 Measuring instrument setting

Spectrum analyzer settings	
Spectrum Analyzer function	Setting
Detector	Peak
RBW	100kHz
VBW	$\geq 3 \times \text{RBW}$
Sweep	Auto couple
Trace	Allow the trace to stabilize.
Span	Between two times and five times the occupied bandwidth
Attenuation	Auto

3.4 Test procedure

1. The transmitter output was connected to the spectrum analyzer.
2. Test was performed in accordance with clause 8.1 option1 of KDB 558074 D01
3. Measure the maximum width of the emission that is constrained by the frequencies associated with the two outermost amplitude points (upper and lower frequencies) that are attenuated by 6 dB relative to the maximum level measured in the fundamental emission

3.5 Test diagram

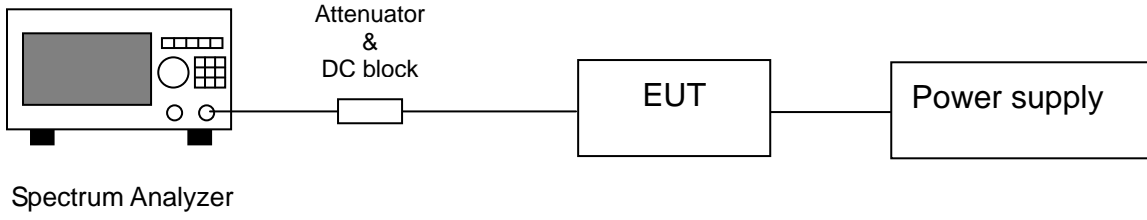

3.6 Test results

Mode	Channel	Frequency (MHz)	6dB Bandwidth (MHz)	Limit (MHz)	Pass/Fail
BT4.0	Low	2402	0.659	0.5	Pass
	Middle	2442	0.638	0.5	Pass
	High	2480	0.653	0.5	Pass

Chain0 : 6dB Bandwidth @ Ch Low

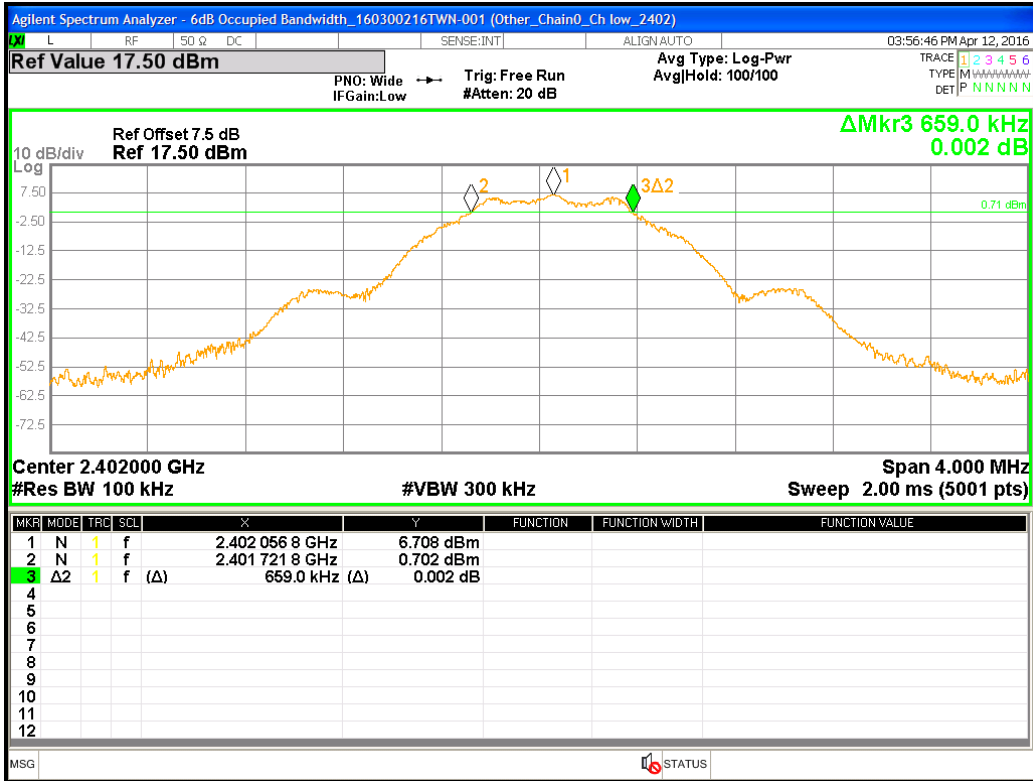

Chain0 : 6dB Bandwidth @ Ch Middle

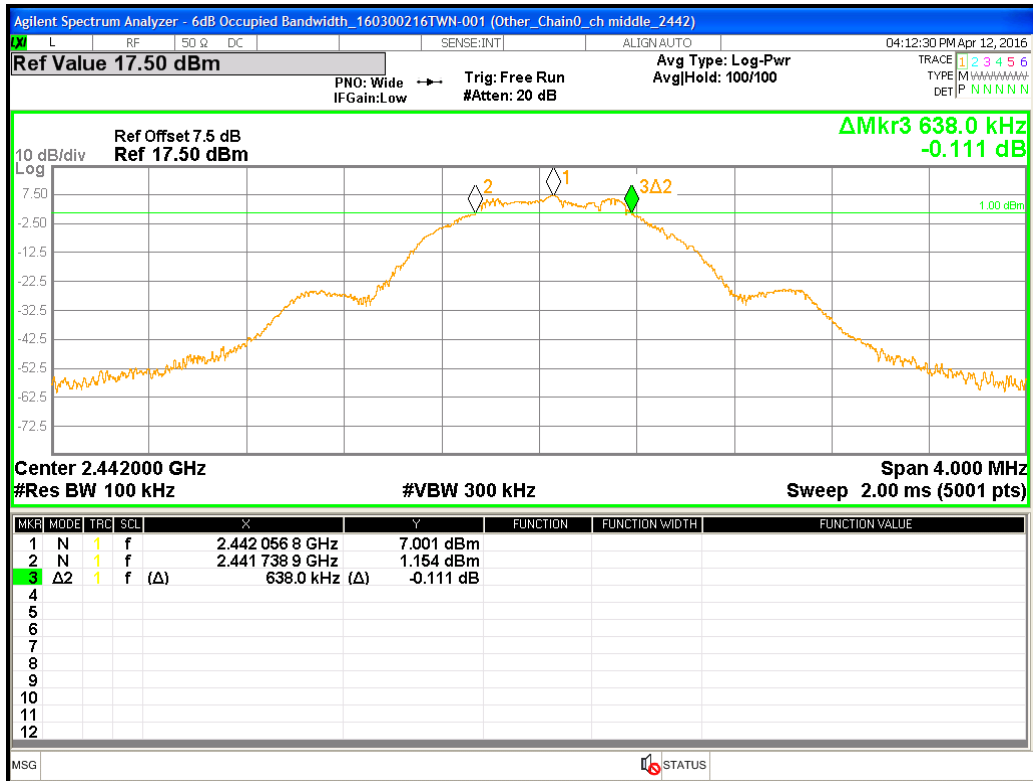

Chain0 : 6dB Bandwidth @ Ch High

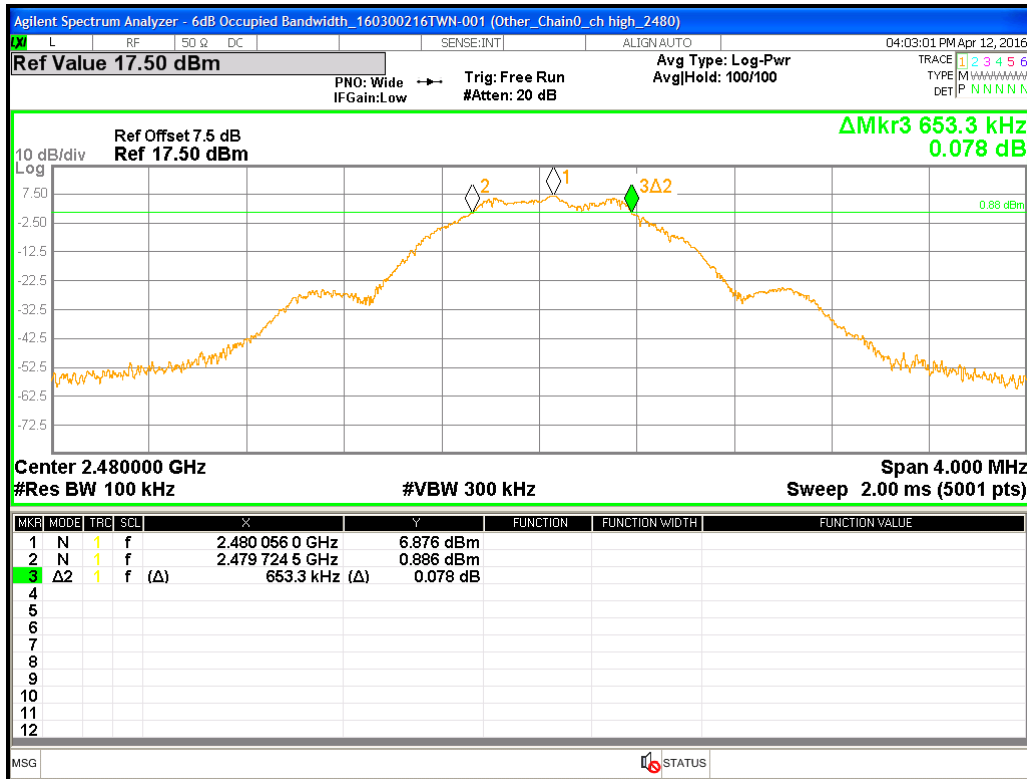

4. Maximum Peak Conducted Output Power

4.1 Operating environment

Temperature:	21	°C
Relative Humidity:	55	%
Atmospheric Pressure	1008	hPa
Requirement & Test method	15.247(b)(3) 558074 D01 DTS Meas Guidance v04	

4.2 Limit for maximum peak conducted output power

For systems using digital modulation in the 2400-2483.5 MHz: 1 Watt (30dBm)

4.3 Measuring instrument setting

Power meter	
Power meter	Setting
Bandwidth	65MHz bandwidth is greater than the EUT emission bandwidth
Detector	Peak & Average

4.4 Test procedure

Test procedures refer to clause 9.1.3 peak power meter method of KDB 558074 D01.

4.5 Test diagram

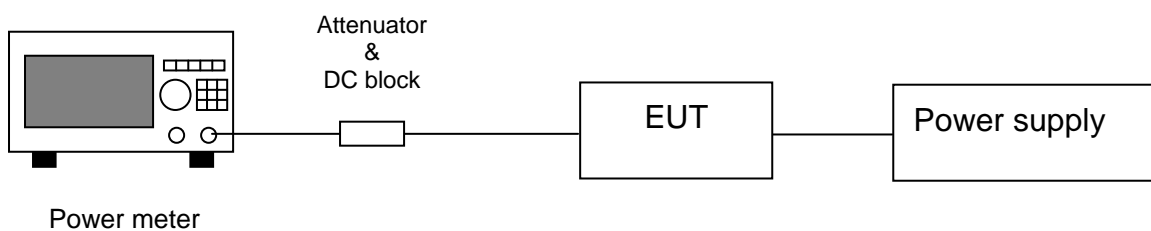

4.6 Test result

Mode	Channel	Frequency (MHz)	Maximum (PK) (dBm)	Maximum (PK) (mW)	Limit (dBm)	Margin (dB)
BT4.0	Low	2402	6.36	4.325	30	-23.64
	Middle	2442	5.93	3.917	30	-24.07
	High	2480	5.78	3.784	30	-24.22

5. Power Spectral Density

5.1 Operating environment

Temperature:	21	°C
Relative Humidity:	55	%
Atmospheric Pressure	1008	hPa
Requirement & Test method	15.247(e) 558074 D01 DTS Meas Guidance v04	

5.2 Limit for power spectrum density

For digitally modulated systems, the power spectral density conducted from the intentional radiator to the antenna shall not be greater than 8 dBm in any 3 kHz band during any time interval of continuous transmission

5.3 Measuring instrument setting

Spectrum analyzer settings	
Spectrum Analyzer function	Setting
Detector	Peak
RBW	≥ 3 kHz
VBW	$\geq 3 \times$ RBW
Sweep	Auto couple
Trace	Max hold
Span	1.5 times x 6dB bandwidth
Attenuation	Auto

5.4 Test procedure

1. Test procedure refer to clause 10.2 method PKPSD (peak PSD) of KDB 558074 D01 and clause E) 2) b) measure.
2. Using the maximum conducted output power in the fundamental emission demonstrates compliance. The EUT must be configured to transmit continuously at full power over the measurement duration.
3. Use the peak marker function to determine the maximum amplitude level within the RBW.

5.5 Test diagram

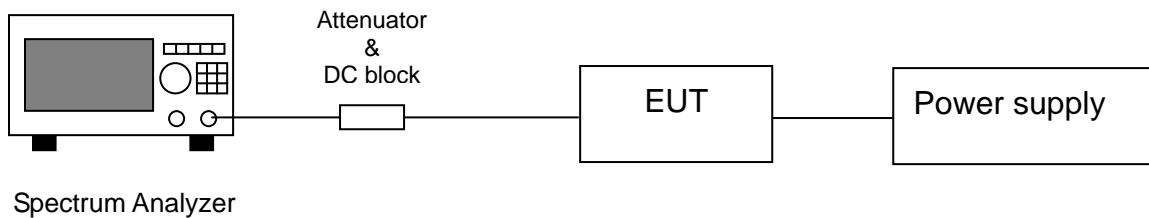

5.6 Test results

Channel	Frequency (MHz)	RBW factor	PSD in 10kHz	PSD in 3kHz		Limit (dBm)	Margin (dB)
				(dBm)	(mW)		
Low	2402	5.229	0.154	-5.075	0.31	8	-13.07
Middel	2442	5.229	0.656	-4.573	0.35	8	-12.57
High	2480	5.229	0.423	-4.806	0.33	8	-12.81

Chain0 : Power Spectral Density @ Ch Low

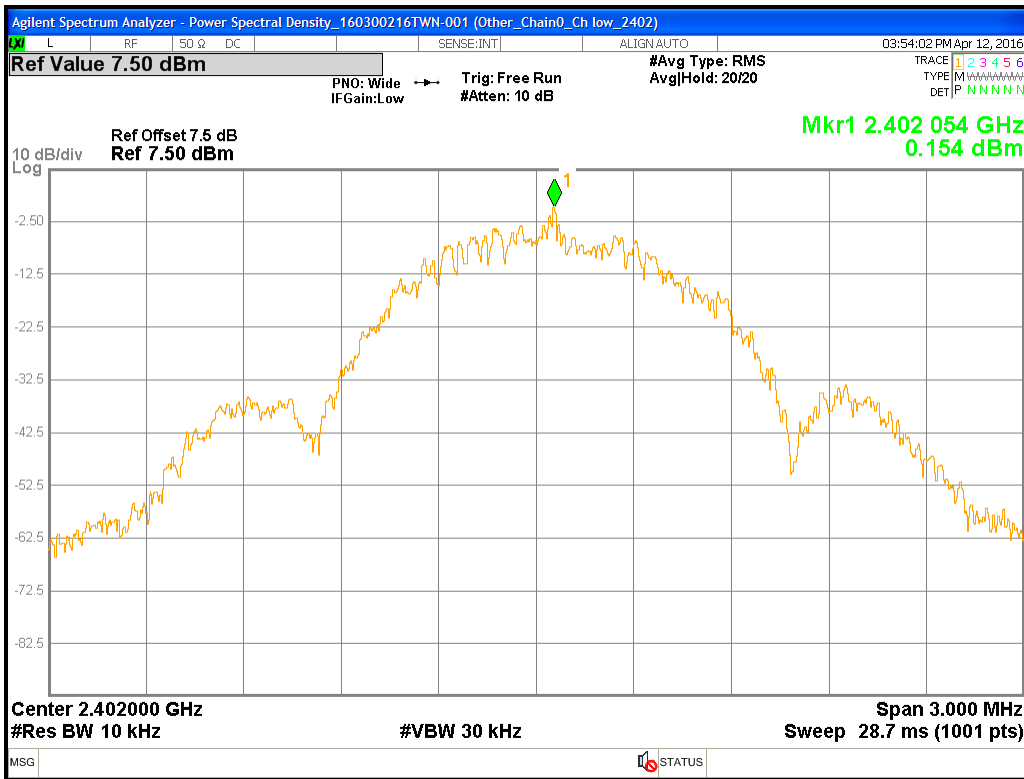

Chain0 : Power Spectral Density @ Ch Middle



Chain0 : Power Spectral Density @ Ch High

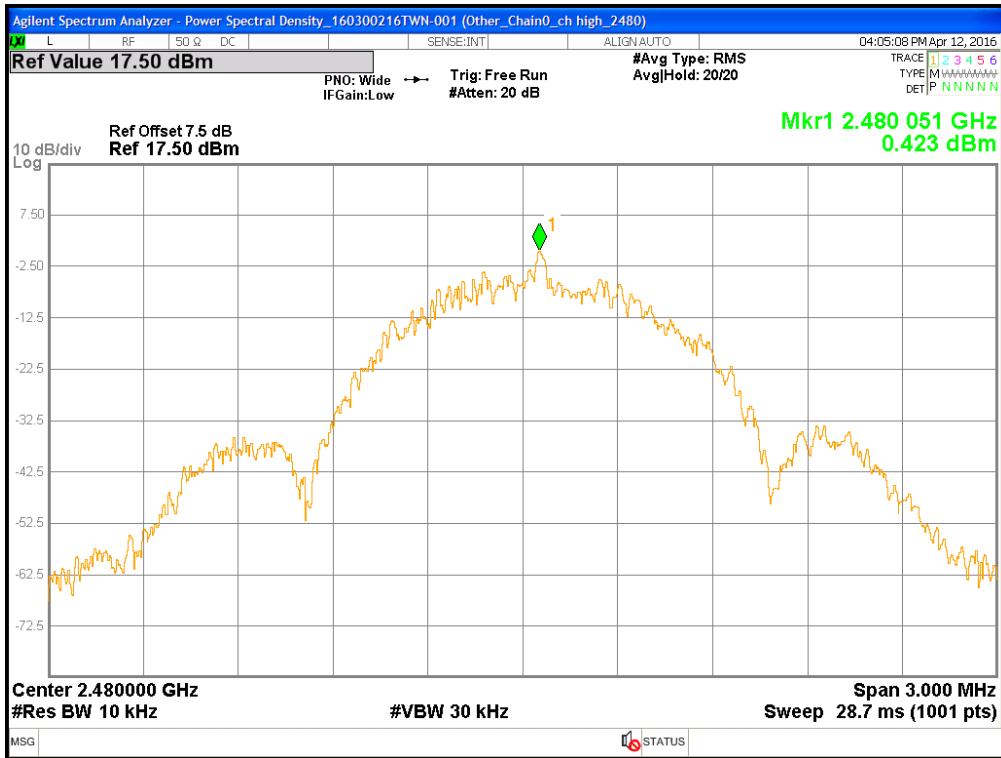

6. Emissions In Non-Restricted Frequency Bands

6.1 Operating environment

Temperature:	20	°C
Relative Humidity:	55	%
Atmospheric Pressure	1008	hPa
Requirement	15.247(d)	

6.2 Limit for emissions in non-restricted frequency bands

The peak output power measured in any 100 kHz bandwidth outside of the authorized frequency band shall be attenuated by at least 20 dB relative to the maximum in-band peak PSD level in 100 kHz

6.3 Measuring instruments setting

Reference level measurement

Spectrum analyzer settings	
Spectrum Analyzer function	Setting
Detector	Peak
RBW	≥ 100 kHz
VBW	$\geq 3 \times$ RBW
Sweep	Auto couple
Trace	Max hold
Span	≥ 1.5 time 6dB bandwidth
Attenuation	Auto

Emission level measurement

Spectrum analyzer settings	
Spectrum Analyzer function	Setting
Detector	Peak
RBW	≥ 100 kHz
VBW	$\geq 3 \times$ RBW
Sweep	Auto couple
Trace	Max hold
Attenuation	Auto

6.4 Test procedure

1. The procedure was used in antenna-port conducted and connected to the spectrum analyzer.
2. Set instrument center frequency to center frequency
3. Use the parameter configured in clause 6.3 to measure
4. Use the peak marker function to determine the maximum amplitude level.

6.5 Test diagram

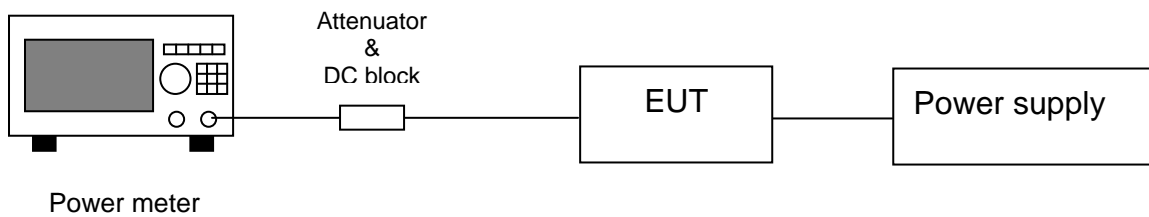

6.6 Test results

Chain0 : Conducted Spurious @ Ch Low

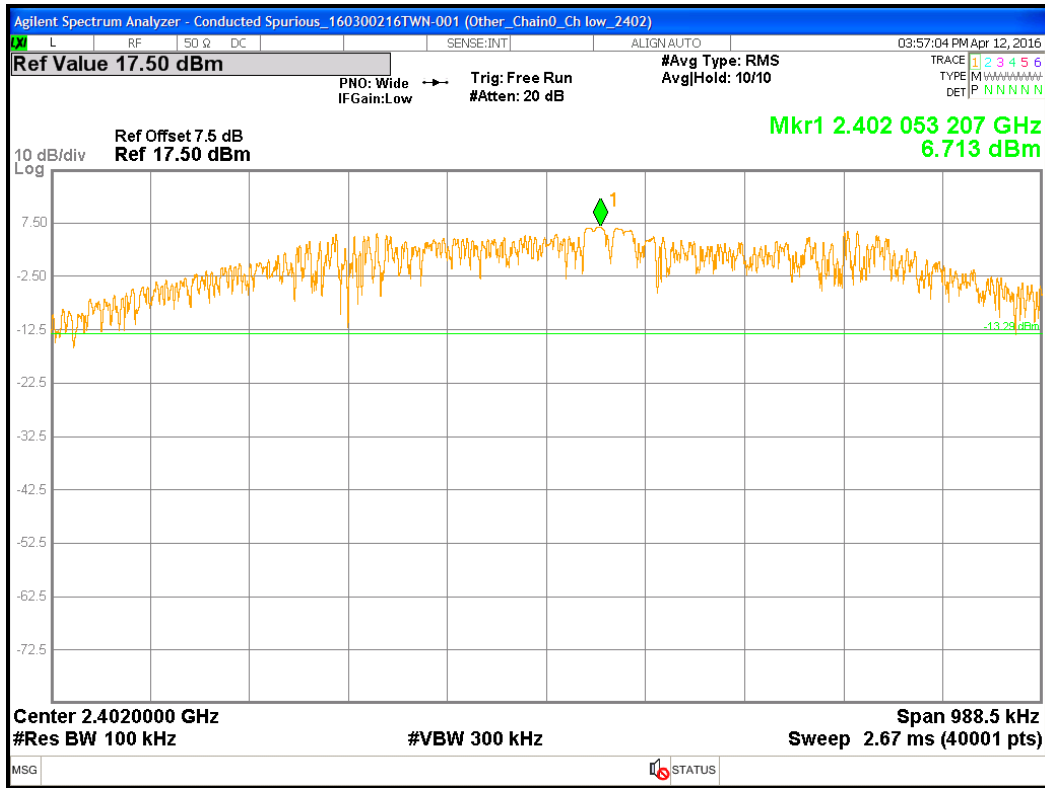

Chain0 : Conducted Spurious @ Ch Low

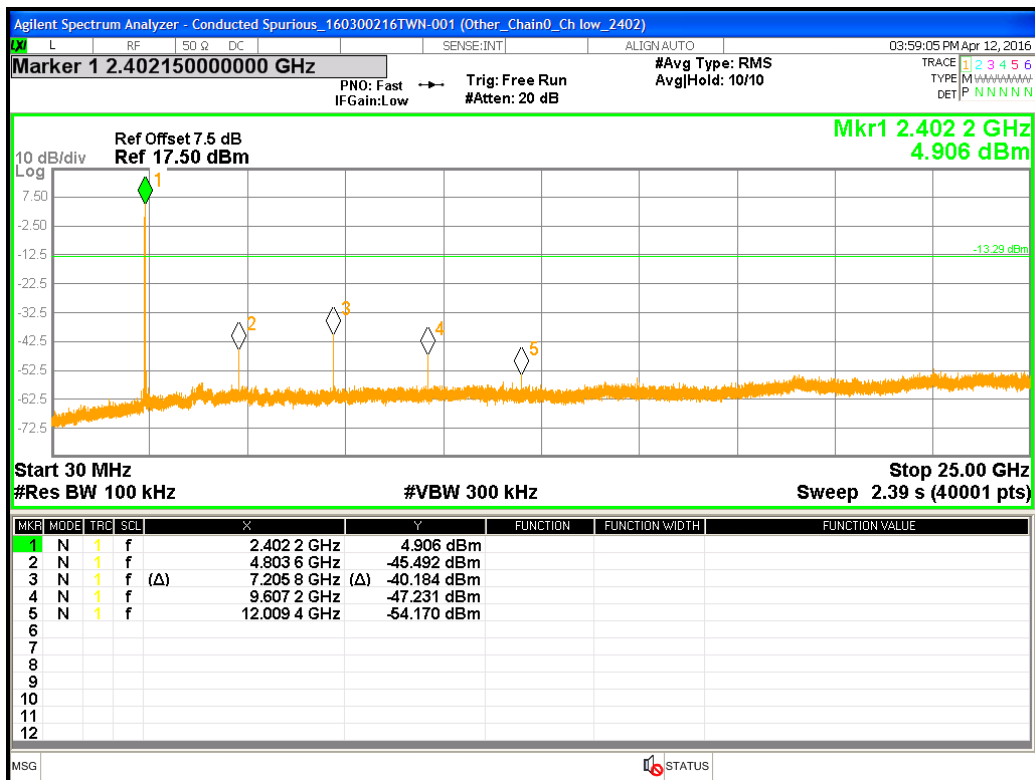

Chain0 : Conducted Spurious @ Ch Middle

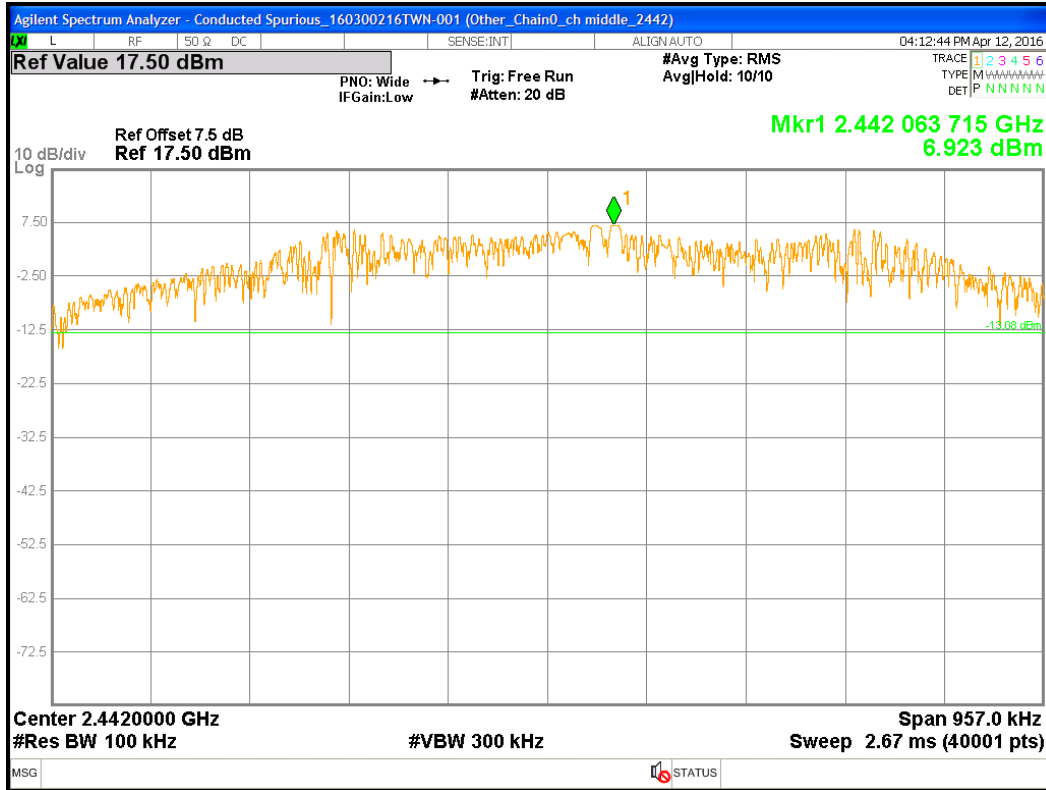

Chain0 : Conducted Spurious @ Ch Middle

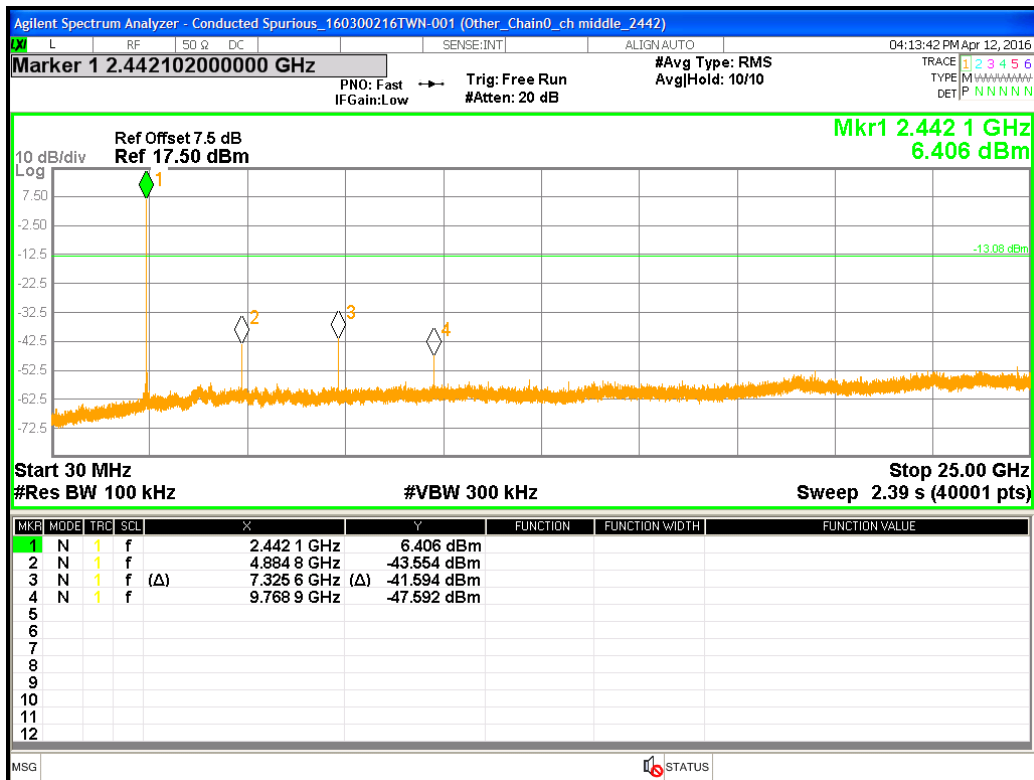

Chain0 : Conducted Spurious @ Ch High

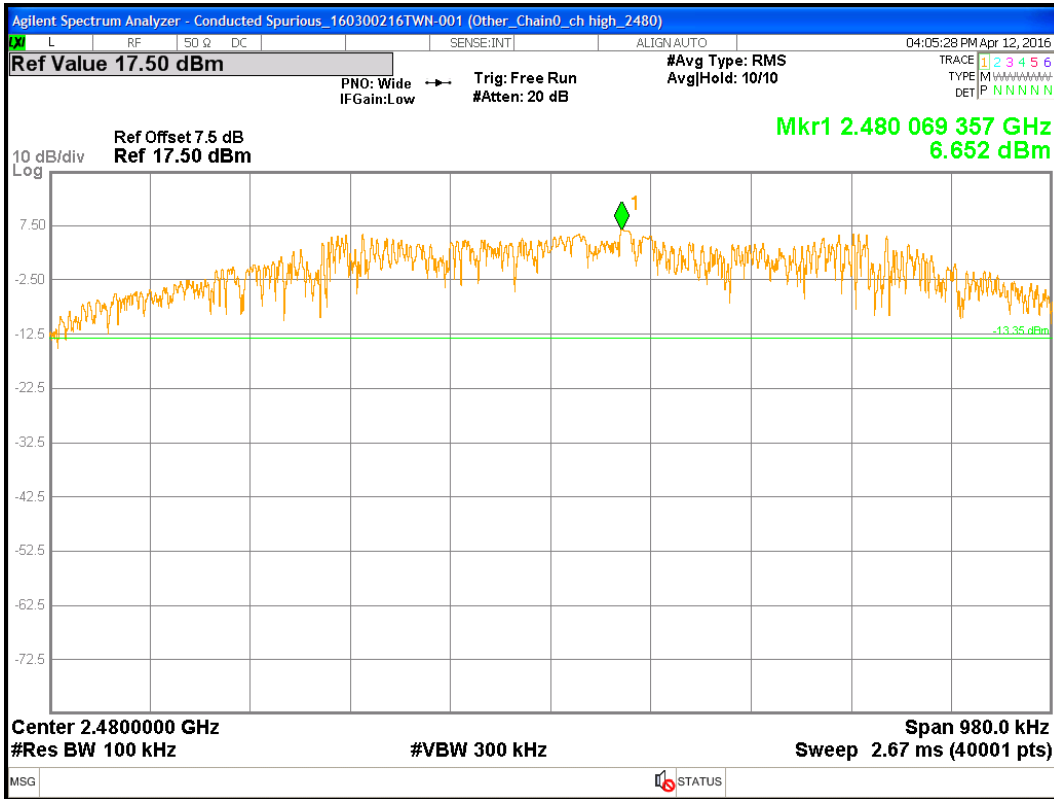

Chain0 : Conducted Spurious @ Ch High

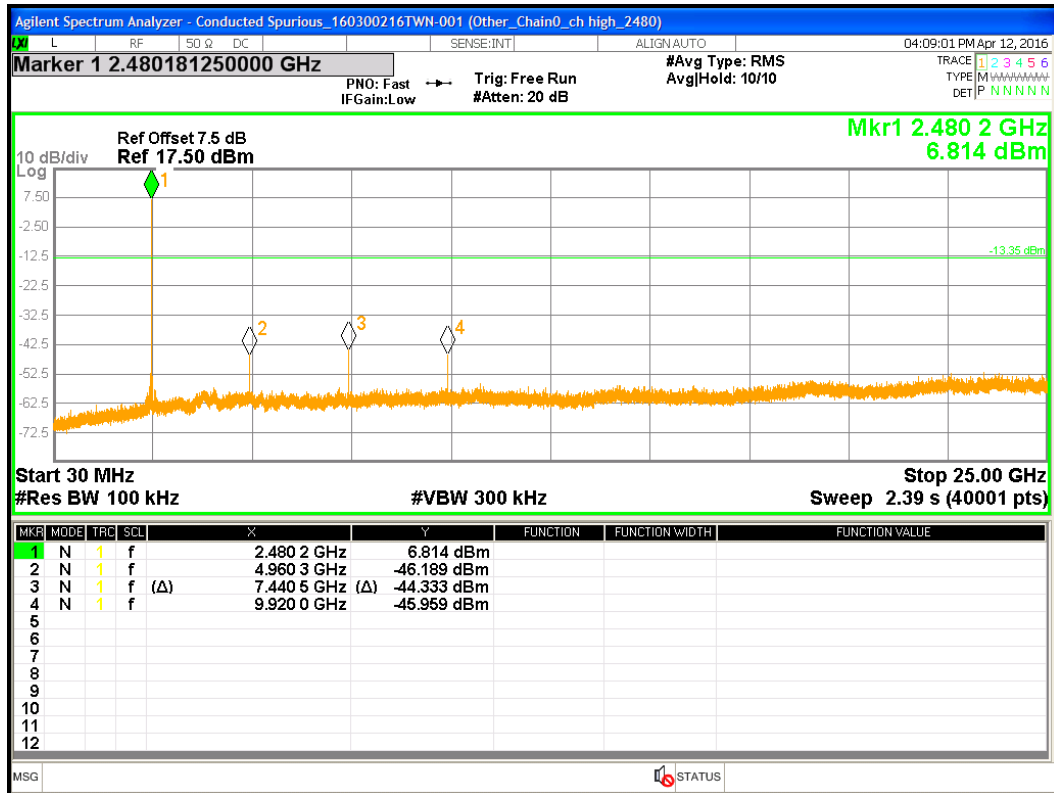

7. Emissions In Restricted Frequency Bands (Radiated emission measurements)

7.1 Operating environment

Temperature:	21	°C
Relative Humidity:	55	%
Atmospheric Pressure	1008	hPa
Requirement	15.247(d), 15.205, 15.209	

7.2 Limit for emission in restricted frequency bands (Radiated emission measurement)

Frequency (MHz)	Field Strength (microvolts/meter)	Measurement distance (meters)
0.009~0.490	2400/F(kHz)	300
0.490~1.705	2400/F(kHz)	30
1.705~30	30	30
30-88	100	3
88-216	150	3
216-960	200	3
Above 960	500	3

Remark:

1. In the above table, the tighter limit applies at the band edges.
2. Distance refers to the distance in meters between the measuring instrument antenna and the closed point of any part of the device or system

7.3 Measuring instrument setting

Below 1GHz measurement

Receiver settings	
Receiver function	Setting
Detector	QP
RBW	9-150 kHz ; 200-300 Hz 0.15-30 MHz; 9-10 kHz 30-1000 MHz; 100-120 kHz
VBW	$\geq 3 \times \text{RBW}$
Sweep	Auto couple
Attenuation	Auto

Above 1GHz measurement

Spectrum analyzer settings	
Spectrum Analyzer function	Setting
Detector	Peak
RBW	1MHz
VBW	3MHz for Peak; 10Hz for Average
Sweep	Auto couple
Start Frequency	1GHz
Stop Frequency	Tenth harmonic
Attenuation	Auto

7.4 Test procedure

1. Configure the EUT according to ANSI C63.10: 2013 The EUT was placed on the top of the turntable 1.5 meter above ground for above 1GHz and placed on the top of the turntable 0.8 meter above ground for below 1GHz. The center of the receiving antenna mounted on the top of a height-variable antenna tower was placed 3 meters far away from the turntable.
2. Power on the EUT and all the companion devices. The turntable was rotated by 360 degree to find the position of the maximum emission level.
3. The height of the receiving antenna was varied between one meter and four meters above ground to find the maximum emission field strength of the both horizontal and vertical polarization
4. If find the frequencies above the limit or below within 3dB, the antenna tower was scan (from 1m to 4m) and then the turntable was rotated to find the maximum reading.
5. Set the test-receiver system to peak or CISPR quasi-peak detector with specified bandwidth under maximum hold mode.
6. For emissions above 1GHz, use 1MHz VBW and 3MHz RBW for peak reading. Then 1MHz RBW and 10Hz VBW for average reading in spectrum analyzer.
7. If the emissions level of the EUT in peak mode was 3dB lower than the average limit specified then testing will be stopped and peak values of the EUT will be reported. Otherwise, the emissions which do not have 3dB margin will be measured using the quasi-peak method for below 1GHz.
8. For testing above 1GHz, The emissions level of the EUT in peak mode was lower than average limit, then testing will be stopped and peak values of the EUT will be reported, otherwise, the emission will be measured in average mode again and reported.
9. In case the emission is lower than 30MHz, loop antenna has to be used for measurement and the recorded data should be quasi-peak measured by receiver.

7.5 Test configuration

7.5.1 Radiated emission from 9kHz to 30MHz uses Loop Antenna:

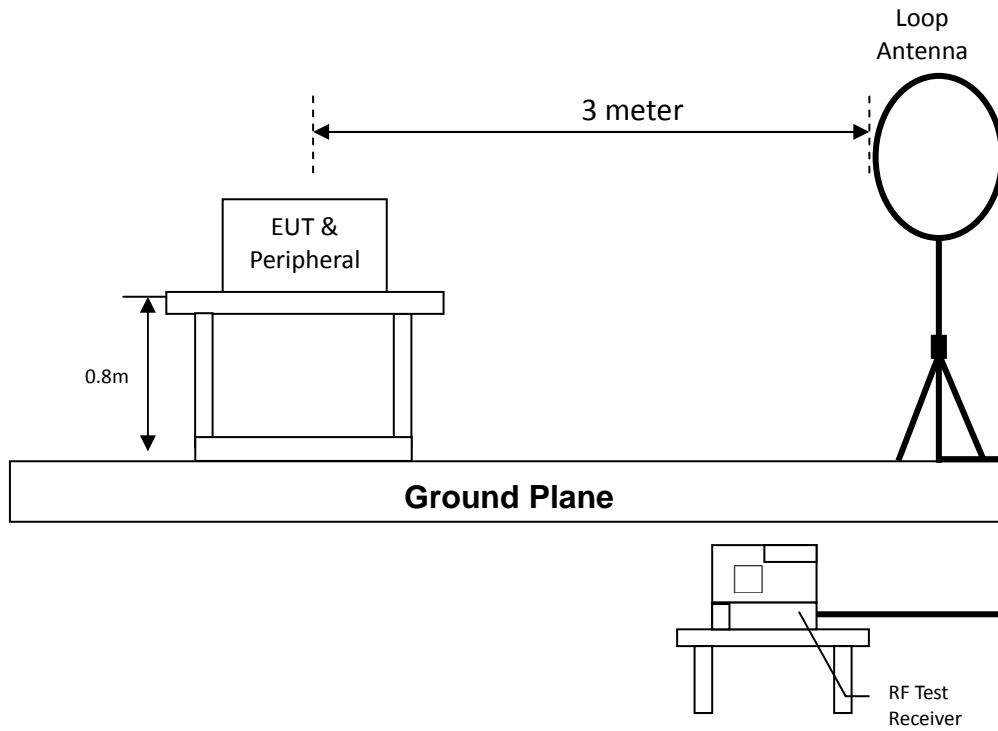

7.5.2 Radiated emission below 1GHz using Bilog Antenna

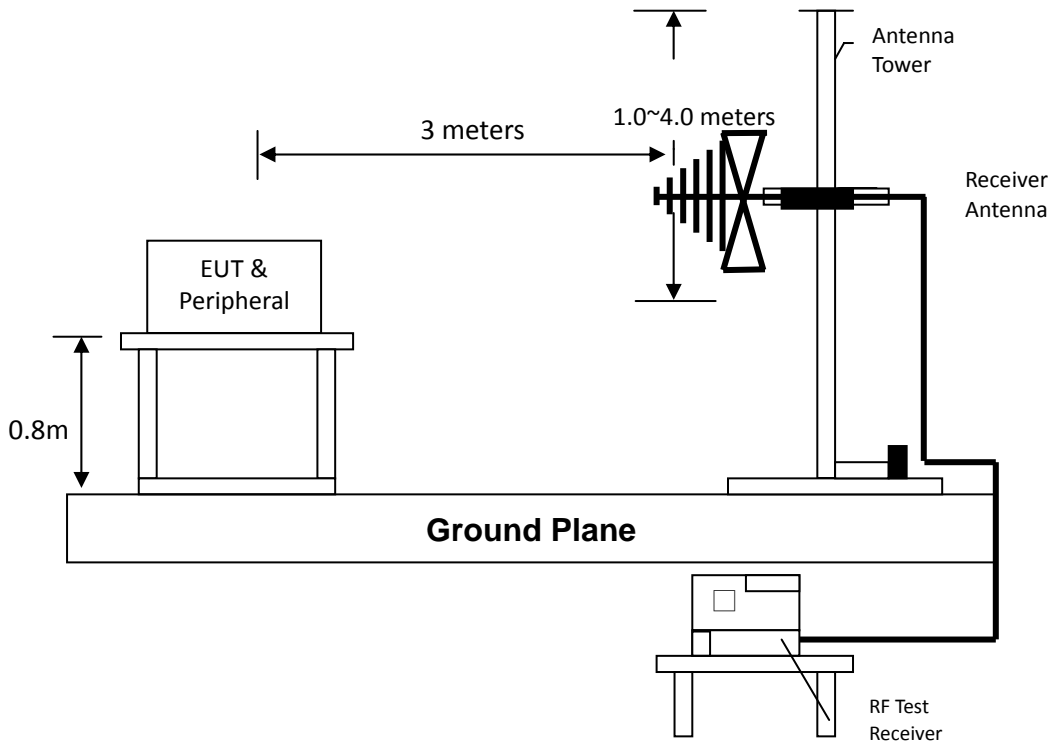

7.5.3 Radiated emission above 1GHz using Horn Antenna

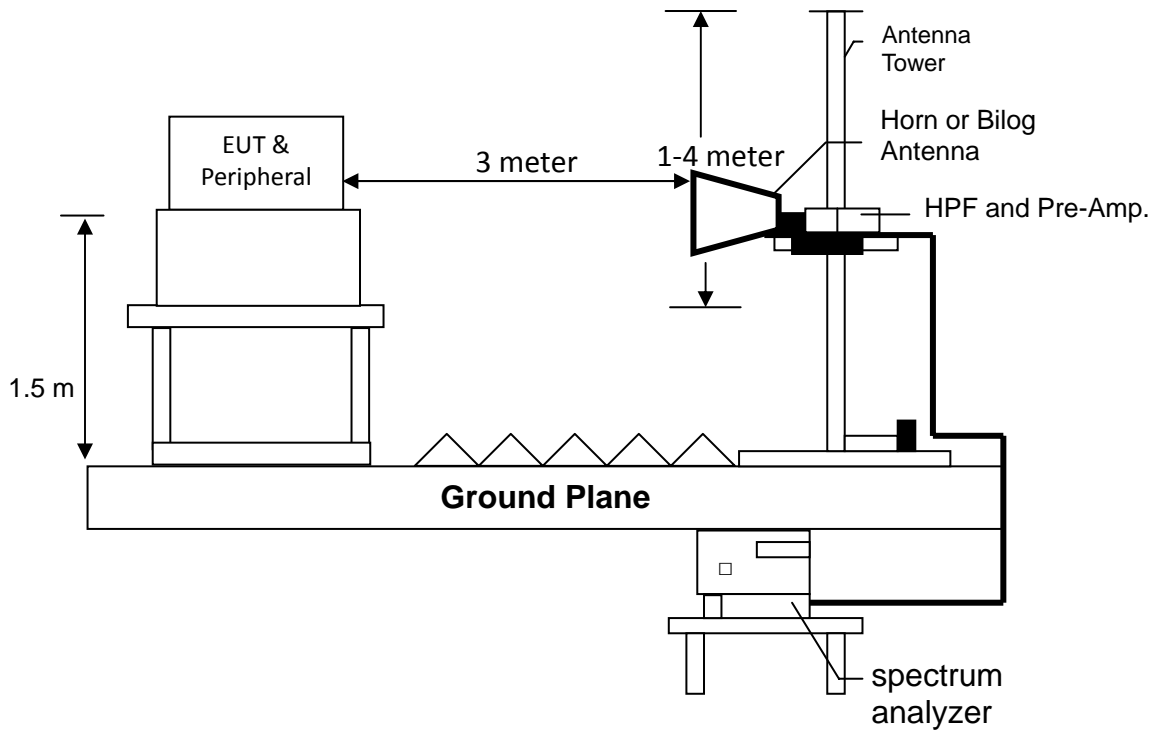

7.6 Test result

7.6.1 Measurement results: frequencies 9kHz to 30MHz

EUT : HURESAC-3XE-C
 Test mode : TX mode High channel
 Test Voltage : 120 Vac

Polarity (circle)	Frequency (MHz)	Detection value	factor (dB/m)	Reading (dBμV)	Value (dBμV/m)	Limit @ 3m (dBμV/m)	Tolerance (dB)
Plane	0.02	QP	20.92	13.52	34.435	200.00	-165.57
Plane	0.03	QP	20.86	18.39	39.250	160.00	-120.75
Plane	0.07	QP	20.81	17.40	38.206	114.29	-76.08
Plane	0.13	QP	20.77	6.00	26.769	98.46	-71.69
Plane	0.27	QP	20.76	24.38	45.142	88.89	-43.75

Remark: Corr. Factor = Antenna Factor + Cable Loss - PreAmplifier Gain

7.6.2 Measurement results: frequencies below 1 GHz

The test was performed on EUT under GFSK continuously transmitting mode. The worst case occurred at Tx High channel

EUT :HURESAC-3XE-C
Worst Case : GFSK at Tx High channel
Test Voltage : 120 Vac

Antenna Polariz. (V/H)	Freq. (MHz)	Receiver Detector	Corr. Factor (dB/m)	Reading (dBμV)	Corrected Level (dBμV/m)	Limit @ 3 m (dBμV/m)	Margin (dB)
Vertical	35.82	QP	15.88	25.06	33.95	40.00	-6.05
Vertical	47.46	QP	16.97	19.23	35.96	40.00	-4.04
Vertical	95.96	QP	11.05	15.67	39.60	43.50	-3.90
Vertical	142.52	QP	16.16	21.70	33.77	43.50	-9.73
Vertical	288.02	QP	17.06	16.75	39.16	46.00	-6.84
Vertical	528.58	QP	22.60	11.30	31.32	46.00	-14.68
Horizontal	95.96	QP	14.33	14.91	26.75	43.50	-16.75
Horizontal	212.36	QP	16.37	15.83	30.26	43.50	-13.24
Horizontal	239.52	QP	16.85	17.59	40.66	46.00	-5.34
Horizontal	288.02	QP	17.70	18.56	45.17	46.00	-0.83
Horizontal	334.58	QP	18.52	11.82	31.30	46.00	-14.70
Horizontal	720.64	QP	25.29	10.96	33.13	46.00	-12.87

Remark: Corr. Factor = Antenna Factor + Cable Loss

7.6.3 Measurement results: frequency above 1GHz

EUT :HURESAC-3XE-C
Test Voltage : 120Vac

Mode	Frequency (MHz)	Spectrum Analyzer Detector	Ant. Pol. (H/V)	Preamp. Gain (dB)	Correction Factor (dB/m)	Reading (dBμV)	Corrected Reading (dBμV/m)	Limit @ 3 m (dBμV/m)	Margin (dB)
Ch Low	3180	PK	V	39.87	-3.75	50.73	46.98	74.00	-27.02
	3360	PK	V	39.96	-3.89	46.29	42.40	74.00	-31.60
	4804	PK	V	40.13	-0.10	45.85	45.75	74.00	-28.25
	7206	PK	V	38.11	8.10	57.66	65.76	74.00	-8.24
	7206	AV	V	38.11	8.10	43.33	51.43	54.00	-2.57
	9608	PK	V	38.13	11.38	49.85	61.23	74.00	-12.77
	9608	AV	V	38.13	11.38	36.89	48.27	54.00	-5.73
	3150	PK	H	39.85	-3.73	45.60	41.87	74.00	-32.13
	3690	PK	H	40.17	-3.06	44.98	41.92	74.00	-32.08
	3960	PK	H	40.36	-1.72	45.68	43.96	74.00	-30.04
	4804	PK	H	40.13	-0.10	50.46	50.36	74.00	-23.64
	7206	PK	H	38.11	8.10	57.29	65.39	74.00	-8.61
	7206	AV	H	38.11	8.10	42.97	51.07	54.00	-2.93
	9608	PK	H	38.13	11.38	51.79	63.17	74.00	-10.83
	9608	AV	H	38.13	11.38	38.36	49.74	54.00	-4.26

Remark: Correction Factor = Antenna Factor + Cable Loss + High Pass Filter Loss - Pre_Amplifier Gain

EUT :HURESAC-3XE-C
Test Voltage : 120Vac

Mode	Frequency (MHz)	Spectrum Analyzer Detector	Ant. Pol. (H/V)	Preamp. Gain (dB)	Correction Factor (dB/m)	Reading (dBμV)	Corrected Reading (dBμV/m)	Limit @ 3 m (dBμV/m)	Margin (dB)
Ch Middle	3180	PK	V	39.87	-3.75	47.99	44.24	74.00	-29.76
	3360	PK	V	39.96	-3.89	46.47	42.58	74.00	-31.42
	3960	PK	V	40.36	-1.72	45.16	43.44	74.00	-30.56
	4884	PK	V	39.99	0.16	59.24	59.40	74.00	-14.60
	4884	AV	V	39.99	0.16	46.61	46.77	54.00	-7.23
	7326	PK	V	38.01	8.47	53.72	62.19	74.00	-11.81
	7326	AV	V	38.01	8.47	40.34	48.81	54.00	-5.19
	9768	PK	V	38.36	11.22	53.23	64.45	74.00	-9.55
	9768	AV	V	38.36	11.22	39.15	50.37	54.00	-3.63
	3690	PK	H	40.17	-3.06	45.66	42.60	74.00	-31.40
	4884	PK	H	39.99	0.16	62.58	62.74	74.00	-11.26
	4884	AV	H	39.99	0.16	48.87	49.03	54.00	-4.97
	7326	PK	H	38.01	8.47	52.24	60.71	74.00	-13.29
	7326	AV	H	38.01	8.47	38.18	46.65	54.00	-7.35
	9768	PK	H	38.36	11.22	54.17	65.39	74.00	-8.61
	9768	AV	H	38.36	11.22	40.25	51.47	54.00	-2.53

Remark: Correction Factor = Antenna Factor + Cable Loss + High Pass Filter Loss - Pre_Amplifier Gain

EUT :HURESAC-3XE-C
Test Voltage : 120Vac

Mode	Frequency (MHz)	Spectrum Analyzer Detector	Ant. Pol. (H/V)	Preamp. Gain (dB)	Correction Factor (dB/m)	Reading (dBμV)	Corrected Reading (dBμV/m)	Limit @ 3 m (dBμV/m)	Margin (dB)
Ch High	3180	PK	V	39.87	-3.75	50.30	46.55	74.00	-27.45
	3990	PK	V	40.38	-1.57	44.33	42.76	74.00	-31.24
	4960	PK	V	39.84	0.41	61.93	62.34	74.00	-11.66
	4960	AV	V	39.84	0.41	49.21	49.62	54.00	-4.38
	7440	PK	V	37.91	8.82	52.19	61.01	74.00	-12.99
	7440	AV	V	37.91	8.82	39.49	48.31	54.00	-5.69
	9920	PK	V	38.57	11.07	51.88	62.95	74.00	-11.05
	9920	AV	V	38.57	11.07	39.79	50.86	54.00	-3.14
	12400	PK	V	38.49	13.18	43.53	56.71	74.00	-17.29
	12400	AV	V	38.49	13.18	37.31	50.49	54.00	-3.51
	3150	PK	H	39.85	-3.73	45.85	42.12	74.00	-31.88
	3690	PK	H	40.17	-3.06	46.16	43.10	74.00	-30.90
	4960	PK	H	39.84	0.41	62.03	62.44	74.00	-11.56
	4960	AV	H	39.84	0.41	48.83	49.24	54.00	-4.76
	7440	PK	H	37.91	8.82	53.45	62.27	74.00	-11.73
	7440	AV	H	37.91	8.82	39.99	48.81	54.00	-5.19
	9920	PK	H	38.57	11.07	53.73	64.80	74.00	-9.20
	9920	AV	H	38.57	11.07	40.47	51.54	54.00	-2.46

Remark: Correction Factor = Antenna Factor + Cable Loss + High Pass Filter Loss - Pre_Amplifier Gain

8. Emission On Band Edge

8.1 Operating environment

Temperature:	25	°C
Relative Humidity:	50	%
Atmospheric Pressure	1008	hPa
Requirement	15.247(d), 15.205,	

8.2 Measuring instrument setting

Spectrum analyzer settings	
Spectrum Analyzer function	Setting
Detector	Peak
RBW	1MHz
VBW	3MHz for Peak; 10Hz for Average
Sweep	Auto couple
Restrict bands	2310~2390MHz
	2483.5 ~2500MHz
Attenuation	Auto

8.3 Test procedure

The test procedure is the same as clause 7.4

8.4 Test results

Mode	Frequency (MHz)	Spectrum Analyzer Detector	Ant. Pol. (H/V)	Correction Factor (dB/m)	Reading (dBμV)	Corrected Reading (dBμV/m)	Limit @ 3 m (dBμV/m)	Margin (dB)	Restricted band (MHz)
BT4.0	2375.77	PK	V	33.78	20.04	53.82	74	-20.18	2310~2390
	2372.88	AV	V	33.77	7.88	41.65	54	-12.35	
	2483.86	PK	V	34.30	21.44	55.74	74	-18.26	2483.5~2500
	2487.45	AV	V	34.32	7.78	42.10	54	-11.90	

Remark: Correction Factor = Antenna Factor + Cable Loss

Chain0 : 20dBc @ Ch Low

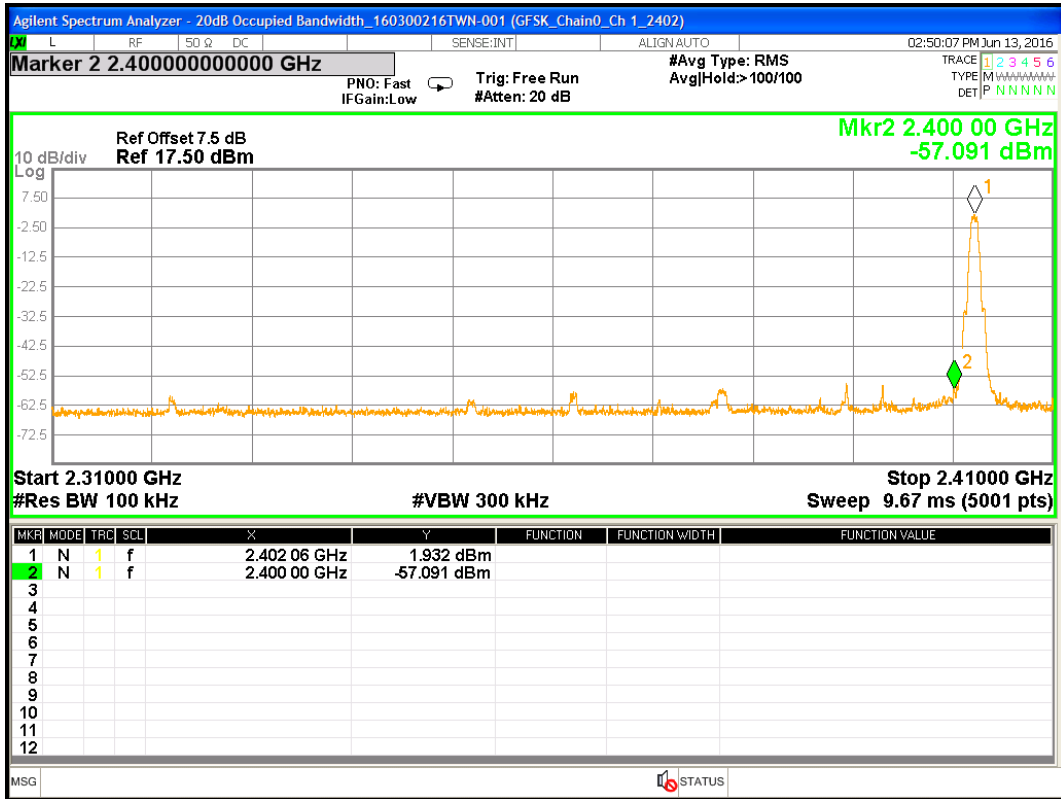

Chain0 : 20dBc @ Ch High

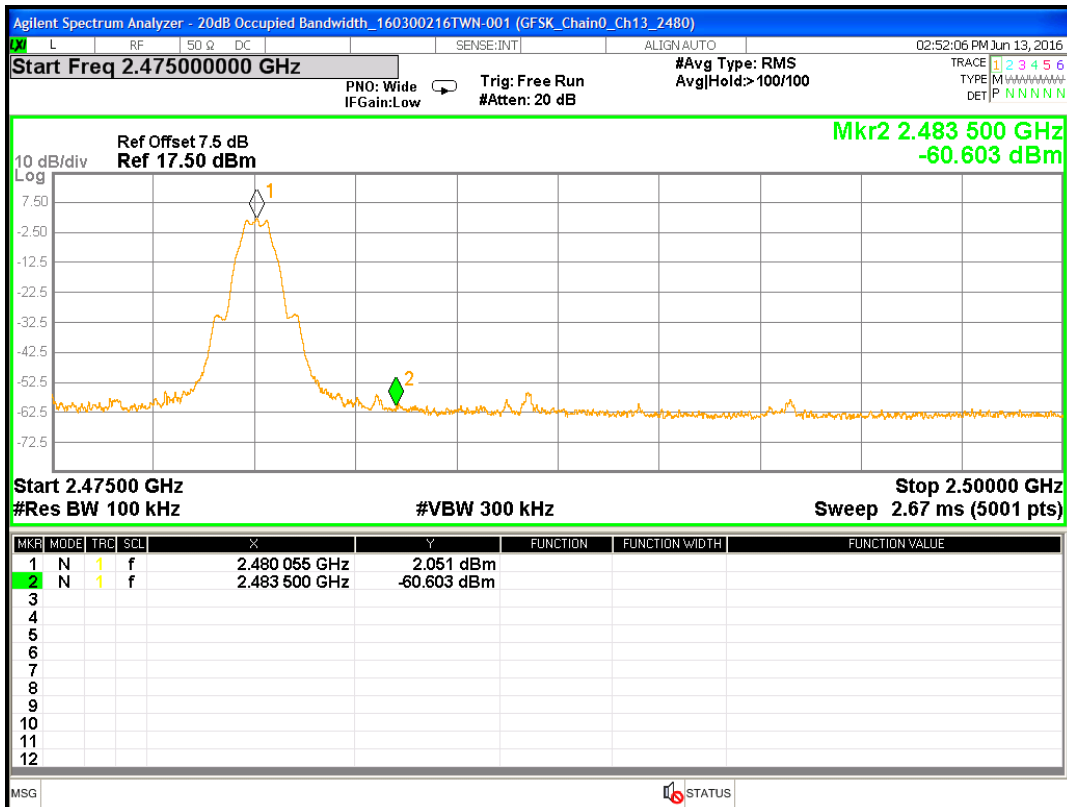

Chain0 : Band Edge @ GFSK mode Low Channel PK

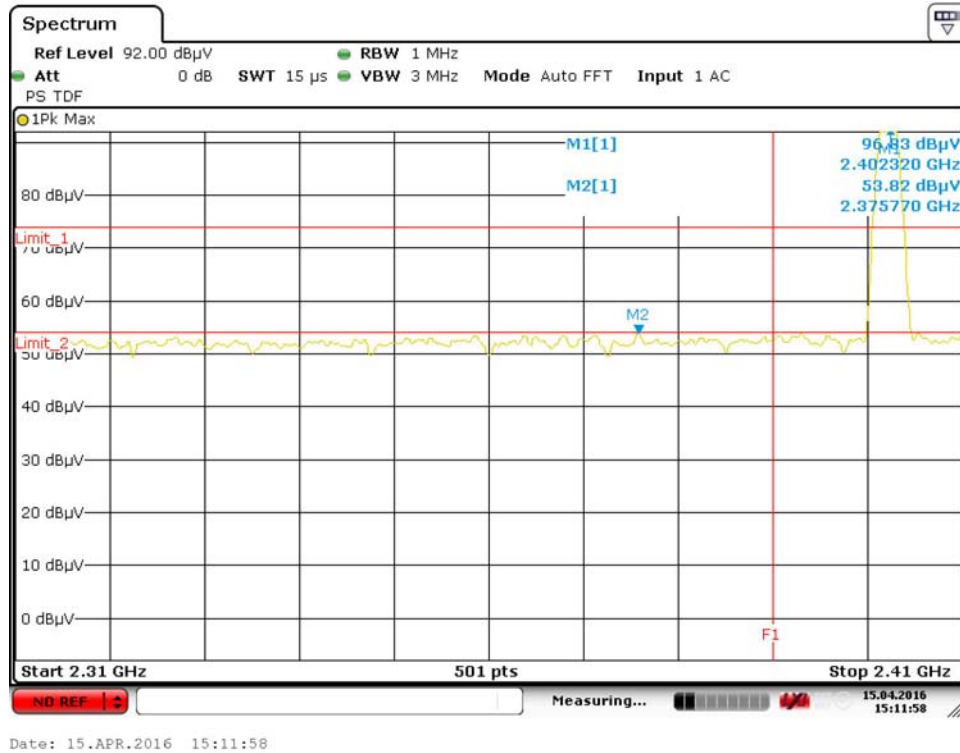

Chain0 : Band Edge @ GFSK mode Low Channel AV

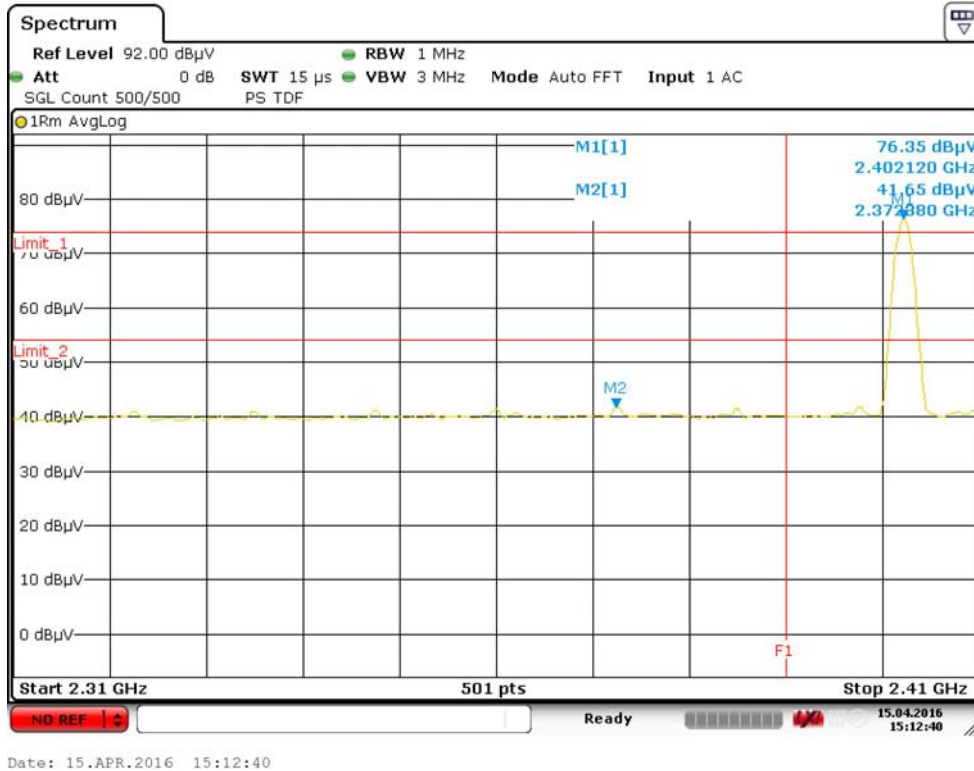

Chain0 : Band Edge @ GFSK mode High Channel PK

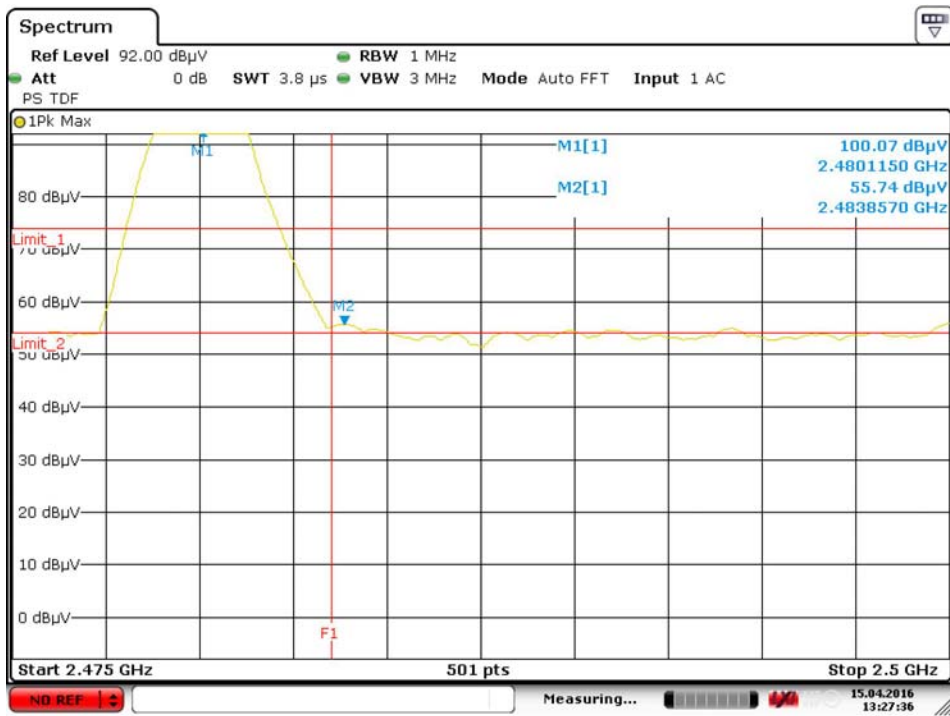

Date: 15.APR.2016 13:27:36

Chain0 : Band Edge @ GFSK mode High Channel AV

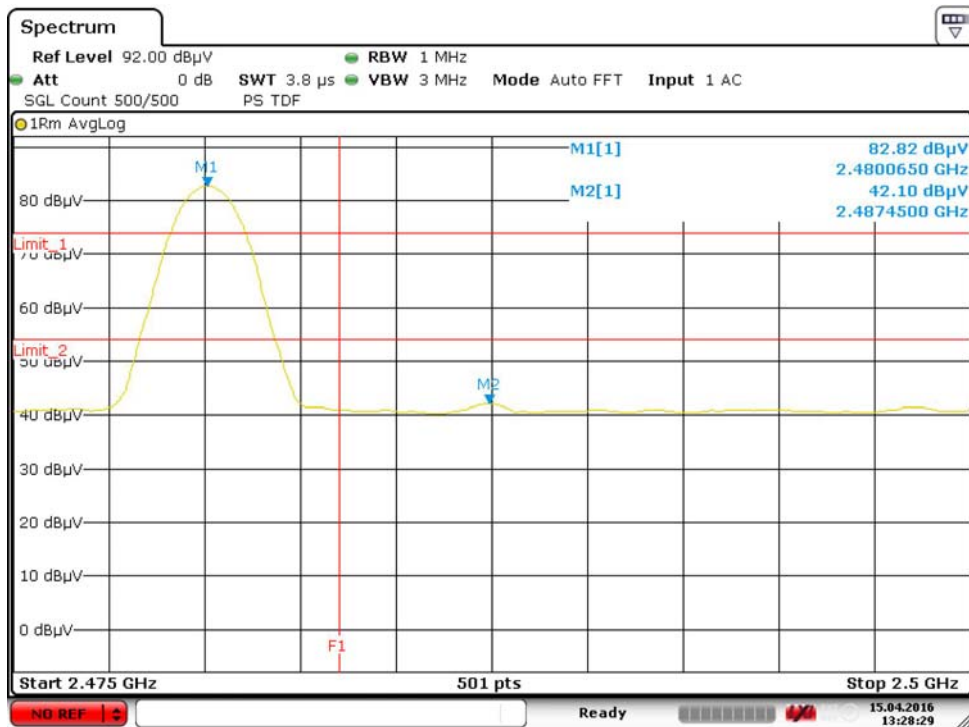

Date: 15.APR.2016 13:28:30

9. AC Power Line Conducted Emission

9.1 Operating environment

Temperature:	26	°C
Relative Humidity:	54	%
Atmospheric Pressure	1008	hPa
Requirement	15.207	

9.2 Limit for AC power line conducted emission

Freq. (MHz)	Conducted Limit (dBuV)	
	Q.P.	Ave.
0.15~0.50	66 – 56*	56 – 46*
0.50~5.00	56	46
5.00~30.0	60	50

9.3 Measuring instrument setting

Receiver settings	
Receiver function	Setting
Detector	QP
Start frequency	0.15MHz
Stop frequency	30MHz
IF bandwidth	9 kHz
Attenuation	10dB

9.4 Test procedure

1. Configure the EUT according to ANSI C63.10:2013. The EUT or host of EHT has to be placed 0.4 meter far from the conducting wall of the shielding room and at least 80 centimeters from any other grounded conducting surface.
2. Connect EUT or host of EUT to the power mains through a line impedance stabilization network.

3. All the companion devices are connected to the other LISN. The LISN should provide 50U_h/50ohms coupling impedance.
4. The frequency range from 150 kHz to 30MHz was searched
5. Set the test-receiver system to peak detector and specified bandwidth with maximum hold mode.
6. The measurement has to be done between each power line and ground at the power terminal.

9.5 Test diagram

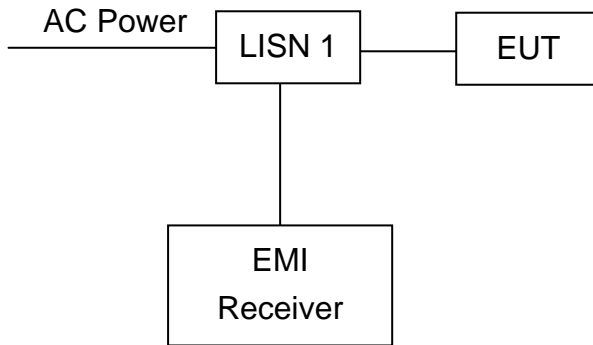

9.6 Test results

Phase : Line
EUT : HURESAC-3XE-C
Test Condition : TX mode

Frequency (MHz)	Corr. Factor (dB)	Level Qp (dBuV)	Limit Qp (dBuV)	Level Av (dBuV)	Limit Av (dBuV)	Margin Qp (dB)	Av
0.152	9.74	51.59	65.91	35.28	55.91	-14.32	-20.63
0.201	9.74	44.60	63.58	30.46	53.58	-18.98	-23.12
0.248	9.74	35.73	61.82	19.11	51.82	-26.09	-32.71
0.305	9.73	30.63	60.10	15.89	50.10	-29.47	-34.21
0.529	9.74	36.29	56.00	33.33	46.00	-19.71	-12.67
3.759	9.86	25.97	56.00	18.48	46.00	-30.03	-27.52

Remark:

1. Corr. Factor (dB) = LISN Factor (dB) + Cable Loss (dB)
2. Margin (dB) = Level (dBuV) – Limit (dBuV)

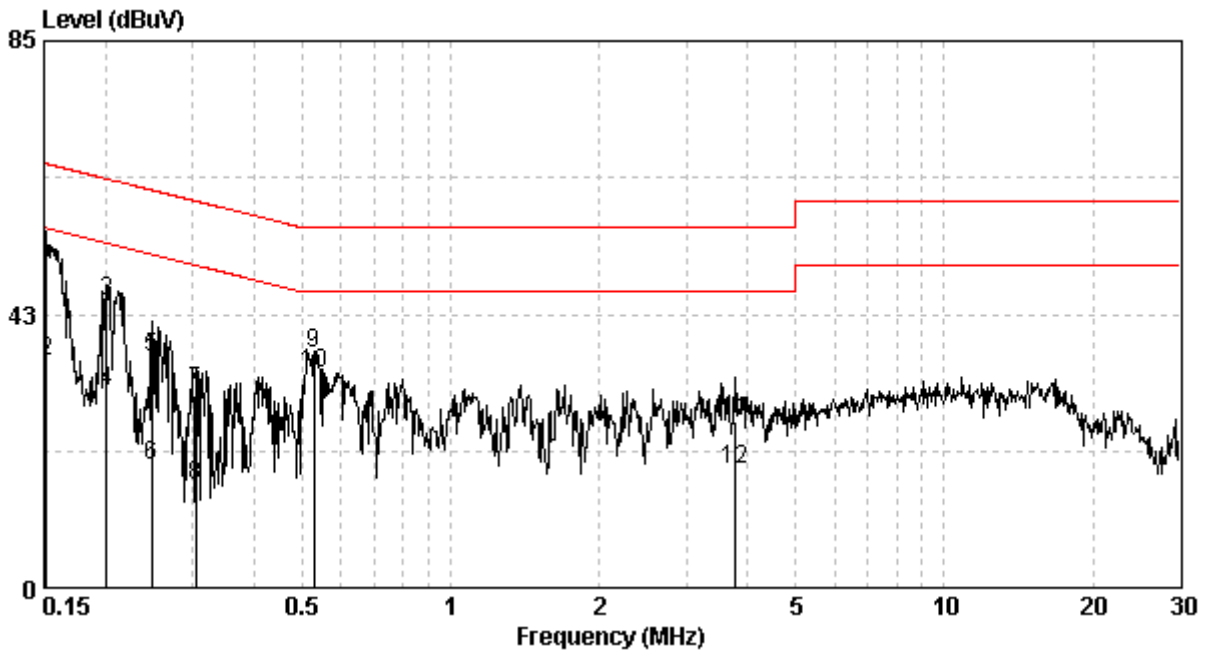

Phase : Neutral
EUT : HURESAC-3XE-C
Test Condition : TX mode

Frequency (MHz)	Corr. Factor (dB)	Level Qp (dBuV)	Limit Qp (dBuV)	Level Av (dBuV)	Limit Av (dBuV)	Margin (dB)	
						Qp	Av
0.152	9.74	51.42	65.87	33.82	55.87	-14.45	-22.04
0.204	9.74	44.60	63.45	30.60	53.45	-18.84	-22.85
0.258	9.74	37.30	61.51	26.47	51.51	-24.22	-25.04
0.307	9.73	32.13	60.06	16.59	50.06	-27.93	-33.47
0.529	9.74	35.74	56.00	30.30	46.00	-20.26	-15.70
3.922	9.86	25.88	56.00	19.23	46.00	-30.12	-26.77

Remark:

1. Corr. Factor (dB) = LISN Factor (dB) + Cable Loss (dB)
2. Margin (dB) = Level (dBuV) – Limit (dBuV)

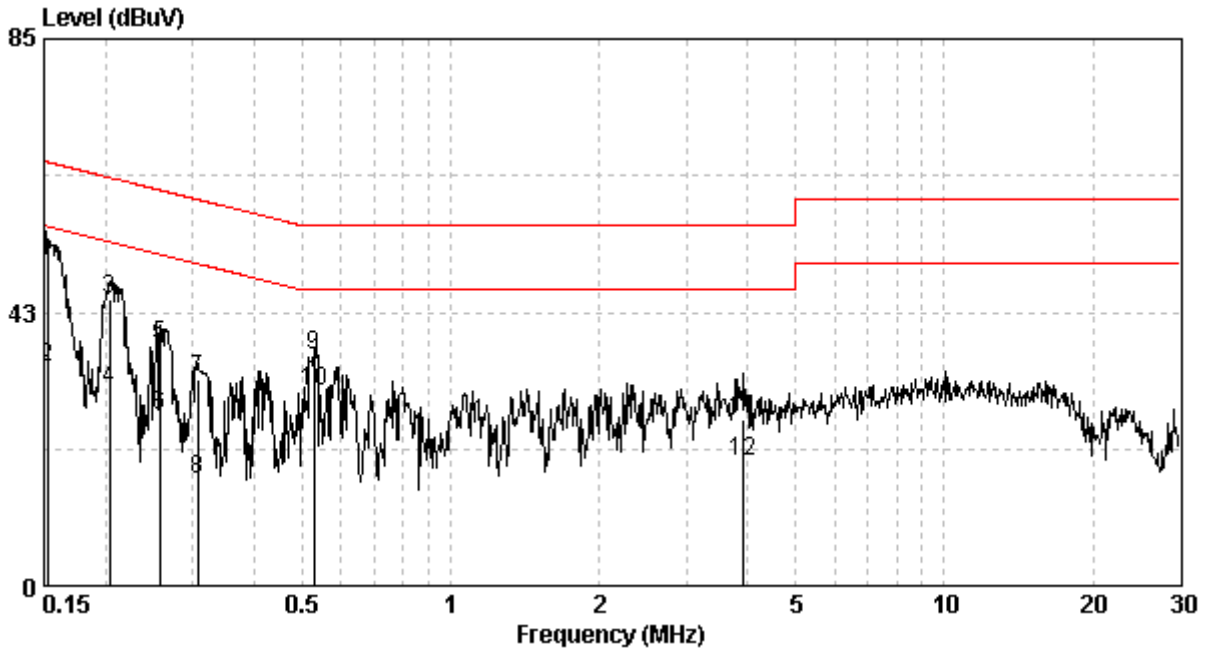

Appendix A: Test equipment list

Equipment	Brand	Model No.	Serial No.	Calibration Date	Next Calibration Date
ESCI EMI Test Receiver	Rohde & Schwarz	ESCI	100018	2015/12/02	2016/11/30
Spectrum Analyzer	Rohde & Schwarz	FSP30	100137	2015/08/18	2016/08/16
Horn Antenna (1-18G)	SHWARZBECK	BBHA 9120 D	9120D-456	2014/08/29	2017/08/27
Horn Antenna (14-42G)	SHWARZBECK	BBHA 9170	BBHA9170159	2014/09/16	2017/09/14
Broadband Antenna	SHWARZBECK	VULB 9168	9168-172	2013/08/08	2016/08/06
Pre-Amplifier	EMC Co.	EMC12635SE	980205	2015/10/7	2016/10/05
Pre-Amplifier	MITEQ	JS4-26004000--27-8A	828825	2015/09/15	2016/09/13
Power Meter	Anritsu	ML2495A	0844001	2015/11/11	2016/11/09
Power Sensor	Anritsu	MA2411B	0738452	2015/11/11	2016/11/09
Two-Line V-Network	Rohde & Schwarz	ENV216	101159	2015/06/08	2016/06/06
Artificial Mains Network (LISN)	Schaffner	MN2050D	1586	2015/05/27	2016/05/25
CON-1 Cable	SUHNER	BNC / RG-58	1521946	2015/05/09	2016/05/07
Test software	Audix	e3	4.2004-1-12k	NCR	NCR
Signal Analyzer	Agilent	N9030A	MY51380492	2015/09/21	2016/09/19
966-2(A) Cable 9kHz~26.5GHz	SUHNER	SMA / EX 100	N/A	2015/05/06	2016/05/05
966-2(B) Cable 9kHz~26.5GHz	SUHNER	SMA / SUCOFLEX 104P	CB0005	2015/05/06	2016/05/04

Equipment	Brand	Model No.	Serial No.	Calibration Date	Next Calibration Date
RF Cable 9kHz~26.5GHz	SUHNER	SUCOFLEX 102	CB0006	2015/05/06	2016/05/05
966-2_3m Semi-Anechoic Chamber	966_2	CEM-966_2	N/A	2016/02/24	2017/02/22
High Pass Filter	Reactel	7HS-3G/18G-S11	N/A	2015/06/06	2016/06/04
Active Loop Antenna	SCHWARZBECK MESS-ELEKTRONIC	FMZB1519	1519-067	2016/03/03	2017/03/02
EMI Test Receiver	Rohde & Schwarz	ESR-7	101232	2015/12/02	2016/11/30
Test software	ADT	Radiated test system	7.5.14	NCR	NCR

Note: No Calibration Required (NCR).

Appendix B: Measurement Uncertainty

This uncertainty represents an expanded uncertainty expressed at approximately the 95 % confidence level using a coverage factor of $k=2$.

Item	Uncertainty
Vertically polarized radiated disturbances from 30MHz~1GHz in a semi-anechoic chamber at a distance of 3m	5.14 dB
Horizontally polarized radiated disturbances from 30MHz~1GHz in a semi-anechoic chamber at a distance of 3m	5.22 dB
Vertically polarized Radiated disturbances from 1GHz~18GHz in a semi-anechoic chamber at a distance of 3m	3.64 dB
Horizontally polarized Radiated disturbances from 1GHz~18GHz in a semi-anechoic chamber at a distance of 3m	3.64 dB
Vertically polarized Radiated disturbances from 18GHz~40GHz in a semi-anechoic chamber at a distance of 3m	2.7 dB
Horizontally polarized Radiated disturbances from 18GHz~40GHz in a semi-anechoic chamber at a distance of 3m	2.7 dB
Radiated disturbances from 9kHz~30MHz in a semi-anechoic chamber at a distance of 3m	3.53 dB
Emission on the Band Edge Test	3.64 dB
Minimum 6 dB Bandwidth	0.85 dB
Maximum Peak Conducted Output Power	0.42 dB
Power Spectral Density	0.85 dB
Emissions In Non-Restricted Frequency Bands	0.85 dB
AC Power Line Conducted Emission	2.47 dB