

EMC

TEST REPORT

Report No. : 150060300210TWN-001
Model No. : HURESAC-3XE-C
Issued Date : Jun. 13, 2016

Applicant: Johnson Health Tech. Co., Ltd.
No. 999, Sec. 2, Dongda Rd., Daya Dist., Taichung City
428, Taiwan

Test Method/ Standard: 47 CFR FCC Part 15.247 & ANSI C63.10 2013
KDB 558074 D01 v03r05

Test Site: 93910
Test By: Intertek Testing Services Taiwan Ltd.
No. 11, Lane 275, Ko-Nan 1 Street, Chia-Tung Li,
Shiang-Shan District, Hsinchu City, Taiwan

It may be duplicated completely for legal use with the allowance of the applicant. It shall not be reproduced except in full, without the written approval of Intertek Laboratory. The test result(s) in this report only applies to the tested sample(s).

The test report was prepared by:



Candy Liu/ Assistant

These measurements were taken by:

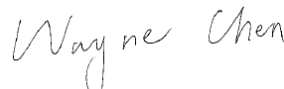

Wayne Chen/ Engineer

The test report was reviewed by:

Name Jimmy Yang

Title Senior Engineer



Revision History

Report No.	Issue Date	Revision Summary
160300210TWN-001	Jun. 13, 2016	Original report

Table of Contents

1. Summary of Test Data.....	4
2. General Information	5
3. Minimum 6 dB Bandwidth	8
4. Maximum Peak Conducted Output Power	12
5. Power Spectral Density	14
6. Emissions In Non-Restricted Frequency Bands.....	18
7. Emissions In Restricted Frequency Bands (Radiated emission measurements) ..	23
8. Emission On Band Edge.....	31
9. AC Power Line Conducted Emission	36
Appendix A: Test equipment list	40
Appendix B: Measurement Uncertainty.....	42

1. Summary of Test Data

Test Requirement	Applicable Rule (Section 15.247)	Result
Minimum 6 dB Bandwidth	15.247(a)(2) KDB 558074 D01 v03r05	Pass
Maximum Peak Conducted Output Power	15.247(b)(3) KDB 558074 D01 v03r05 KDB 662911 D01 v02r01	Pass
Power Spectral Density	15.247(e)	Pass
Emissions In Non-Restricted Frequency Bands	15.247(d)	Pass
Emissions In Restricted Frequency Bands (Radiated emission measurements)	15.247(d), 15.205, 15.209	Pass
Emission On The Band Edge	15.247(d), 15.205	Pass
AC Power Line Conducted Emission	15.207	Pass
Antenna Requirement	15.203	Pass

2. General Information

2.1 Identification of the EUT

Product:	Console for Exercise Machine
Model No:	HURESAC-3XE-C
Radio Module:	MS-57423
Brand Name:	Matrix Fitness
FCC ID:	TN73XEMAXHEADROOM
Operating Frequency:	2402 MHz ~ 2480 MHz
Channel Number:	40 channels
Frequency of Each Channel:	2402+2 k MHz, k=0~39
Access scheme:	GFSK
Rated Power:	DC 12 from adapter
Power Cord:	N/A
Sample Received:	Mar. 08, 2016
Sample condition:	Workable
Test Date(s):	Apr. 21, 2016 ~ Jun. 13, 2016

Note 1: This report is for the exclusive use of Intertek's Client and is provided pursuant to the agreement between Intertek and its Client. Intertek's responsibility and liability are limited to the terms and conditions of the agreement. Intertek assumes no liability to any party, other than to the Client in accordance with the agreement, for any loss, expense or damage occasioned by the use of this report. Only the Client is authorized to permit copying or distribution of this report and then only in its entirety. Any use of the Intertek name or one of its marks for the sale or advertisement of the tested material, product or service must first be approved in writing by Intertek. The observations and test results in this report are relevant only to the sample tested. This report by itself does not imply that the material, product, or service is or has ever been under an Intertek certification program.

Note 2: When determining the test conclusion, the Measurement Uncertainty of test has been considered.

2.2 Description of EUT

Modulation mode	Transmit path
	Chain 0 / Main
BT4.0	V

Product SW version : UI 0.1.7.2, OS 2.0.19, IO 10
 Product HW version : v1.1
 Radio SW version : N/A
 Radio HW version : 0B
 Test SW Version : USI_BCM43XX_Testing_Tool_V1_4_10r8

2.3 Antenna description

The antenna is affixed to the EUT using a unique connector, which allows for replacement of a broken antenna, but DOES NOT use a standard antenna jack or electrical connector.

Antenna Gain : 2.8 dBi
 Antenna Type : PIFA antenna
 Connector Type : I-PEX

2.4 Peripherals equipment

Peripherals	Brand	Model No.	Serial No.	Data cable
Notebook PC	HP	HP Compaq nc2400	CNF6413CGN	Micro USB 0.5 meter × 1
Adapter	N/A	LSE0107A1240	N/A	N/A

2.5 Operation mode

The EUT was supplied with DC 12V from adapter.

TX-MODE is based on a specific test program “USI BCM FCC CE REG Tool”, and the program can select different frequency and modulation.

2.6 Applied test modes and channels

Test items	Mode	Channel	Antenna
Minimum 6 dB Bandwidth	BT 4.0	Low , Middle , High	Chain0
Maximum peak conducted output power	BT 4.0	Low , Middle , High	Chain0
Power Spectral Density	BT 4.0	Low , Middle , High	Chain0
RF Antenna Conducted Spurious	BT 4.0	Low , Middle , High	Chain0
Radiated Spurious Emission 30MHz~1GHz	BT 4.0	Low	Chain0
Radiated Spurious Emission 1GHz~10th Harmonic	BT 4.0	Low , Middle , High	Chain0
Emission on the Band Edge	BT 4.0	Low , High	Chain0
AC Power Line Conducted Emission	BT 4.0	Low	Chain0

3. Minimum 6 dB Bandwidth

3.1 Operating environment

Temperature:	25	°C
Relative Humidity:	50	%
Atmospheric Pressure	1008	hPa
Requirement & Test method	15.247(a)(2) KDB 558074 D01 v03r05	

3.2 Limit for minimum 6dB bandwidth

The minimum 6 dB bandwidth shall be at least 500 kHz.

3.3 Measuring instrument setting

Spectrum analyzer settings	
Spectrum Analyzer function	Setting
Detector	Peak
RBW	100kHz
VBW	$\geq 3 \times \text{RBW}$
Sweep	Auto couple
Trace	Allow the trace to stabilize.
Span	Between two times and five times the occupied bandwidth
Attenuation	Auto

3.4 Test procedure

1. The transmitter output was connected to the spectrum analyzer.
2. Test was performed in accordance with clause 8.1 option1 of KDB 558074 D01
3. Measure the maximum width of the emission that is constrained by the frequencies associated with the two outermost amplitude points (upper and lower frequencies) that are attenuated by 6 dB relative to the maximum level measured in the fundamental

3.5 Test diagram

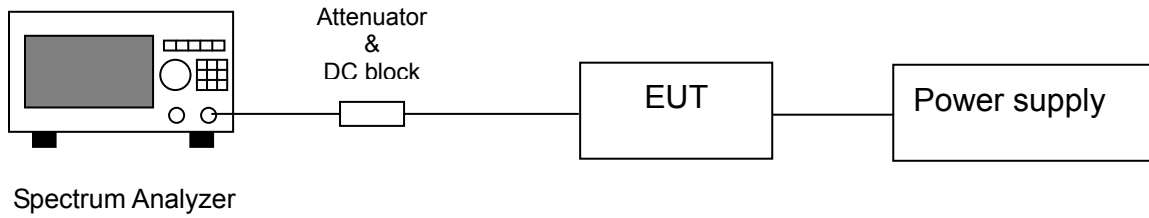

3.6 Test results

Mode	Channel	Frequency (MHz)	6dB Bandwidth (MHz)	Limit (MHz)	Pass/Fail
BT4.0	Low	2402	0.6796	0.5	Pass
	Middle	2442	0.6887	0.5	Pass
	High	2480	0.7026	0.5	Pass

Chain0 : 6dB Bandwidth @ Ch Low

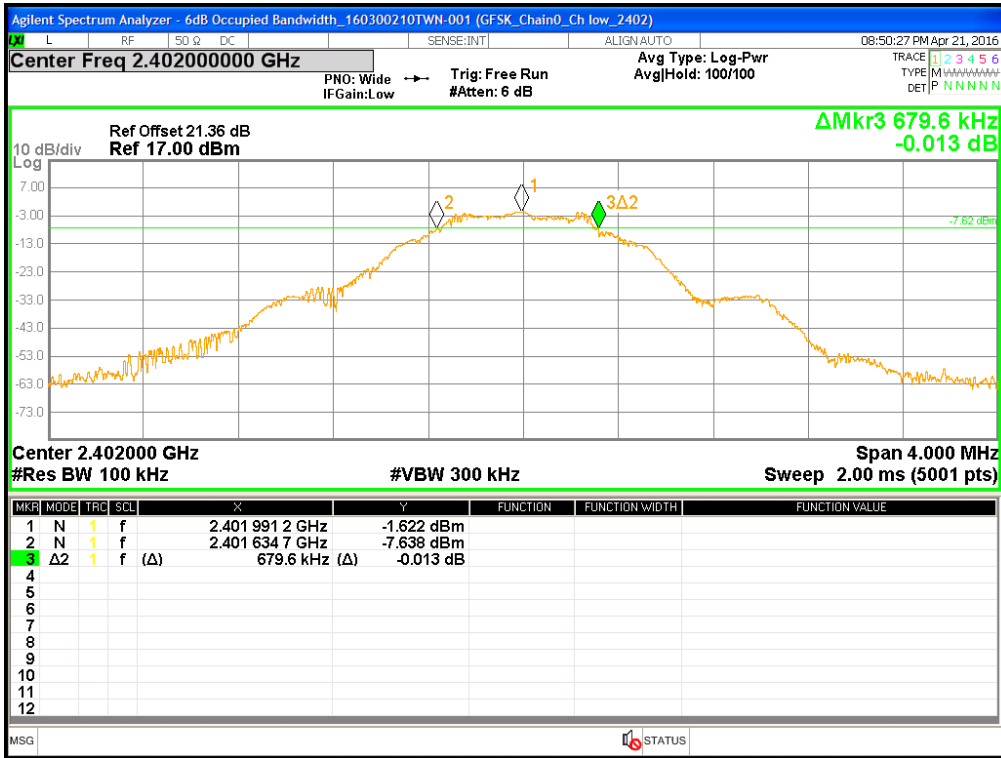

Chain0 : 6dB Bandwidth @ ch Middle

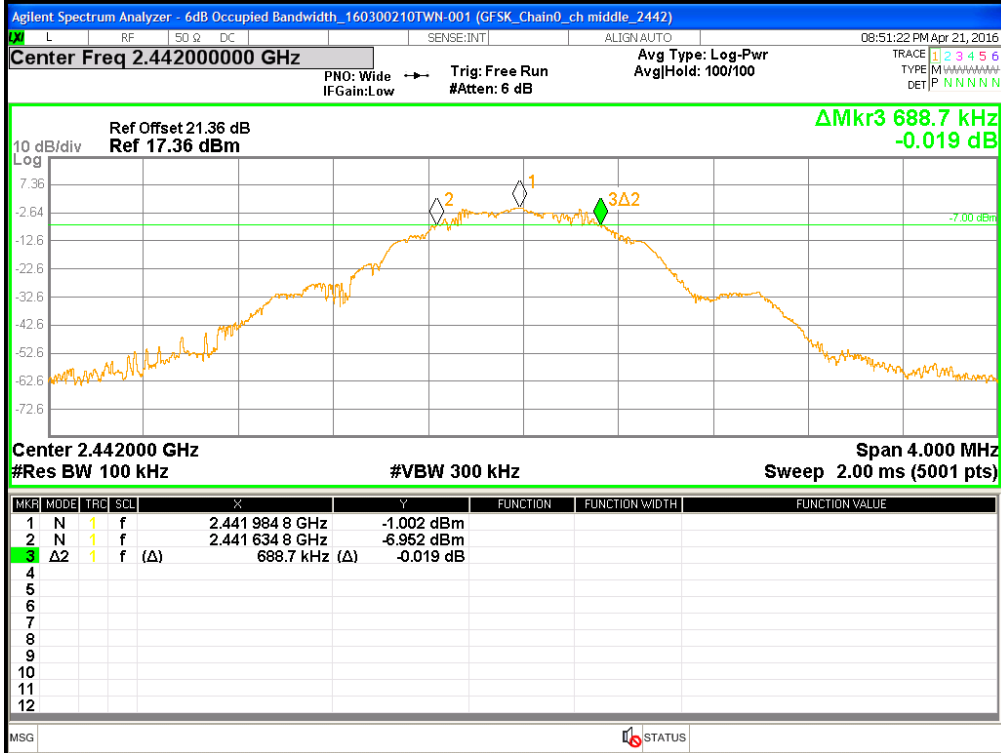

Chain0 : 6dB Bandwidth @ ch High



4. Maximum Peak Conducted Output Power

4.1 Operating environment

Temperature:	25	°C
Relative Humidity:	50	%
Atmospheric Pressure	1008	hPa
Requirement & Test method	15.247(b)(3) KDB 558074 D01 v03r05	

4.2 Limit for maximum peak conducted output power

For systems using digital modulation in the 2400-2483.5 MHz: 1 Watt (30dBm)

4.3 Measuring instrument setting

Power meter	
Power meter	Setting
Bandwidth	65MHz bandwidth is greater than the EUT emission bandwidth
Detector	Peak & Average

4.4 Test procedure

Test procedures refer to clause 9.1.2 peak power meter method and clause 9.2.3.2 measurement using a gated RF average power meter of KDB 558074 D01.

4.5 Test diagram

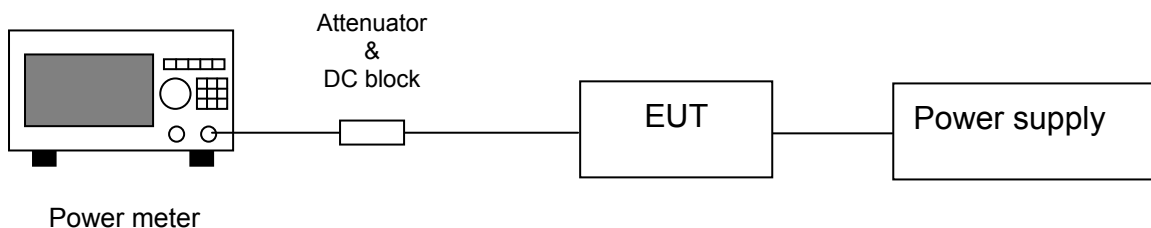

4.6 Test result

Mode	Channel	Frequency (MHz)	Output Power (AV) (dBm)	Total Power (AV) (mW)	Maximun power (PK) (dBm)	Maximun power (PK) (mW)	Limit (dBm)	Margin (dB)
BT 4.0	Low	2402	-2.21	0.60	-2.05	0.6237	30	-32.05
	Middle	2442	-1.84	0.65	-1.69	0.6776	30	-31.69
	High	2480	-1.11	0.77	-0.97	0.7998	30	-30.97

5. Power Spectral Density

5.1 Operating environment

Temperature:	25	°C
Relative Humidity:	50	%
Atmospheric Pressure	1008	hPa
Requirement & Test method	15.247(e) KDB 558074 D01 v03r05	

5.2 Limit for power spectrum density

For digitally modulated systems, the power spectral density conducted from the intentional radiator to the antenna shall not be greater than 8 dBm in any 3 kHz band during any time interval of continuous transmission

5.3 Measuring instrument setting

Spectrum analyzer settings	
Spectrum Analyzer function	Setting
Detector	Peak
RBW	≥ 3 kHz
VBW	$\geq 3 \times$ RBW
Sweep	Auto couple
Trace	Max hold
Span	1.5 times x 6dB bandwidth
Attenuation	Auto

5.4 Test procedure

1. Test procedure refer to clause 10.2 method PKPSD (peak PSD) of KDB 558074 D01 and clause E) 2) b) measure and sum spectral maxima across the outputs of KDB 662911
2. Using the maximum conducted output power in the fundamental emission demonstrates compliance. The EUT must be configured to transmit continuously at full power over the measurement duration.
3. Use the peak marker function to determine the maximum amplitude level within the RBW.

5.5 Test diagram

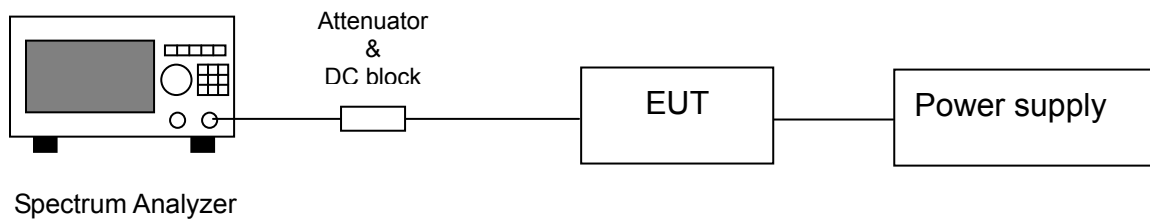

5.6 Test results

Mode	Channel	Frequency (MHz)	Correction Factor	PSD in 10kHz	PSD in 3kHz		Limit (dBm)	Margin (dB)
					(dBm)	(mw)		
BT 4.0	Low	2402	5.229	-9.962	-15.191	0.030	8	-23.19
	Middle	2442	5.229	-9.319	-14.548	0.035	8	-22.55
	High	2480	5.229	-9.488	-14.717	0.034	8	-22.72

Chain0 : Power Spectral Density @ Ch Low



Chain0 : Power Spectral Density @ Ch Middle

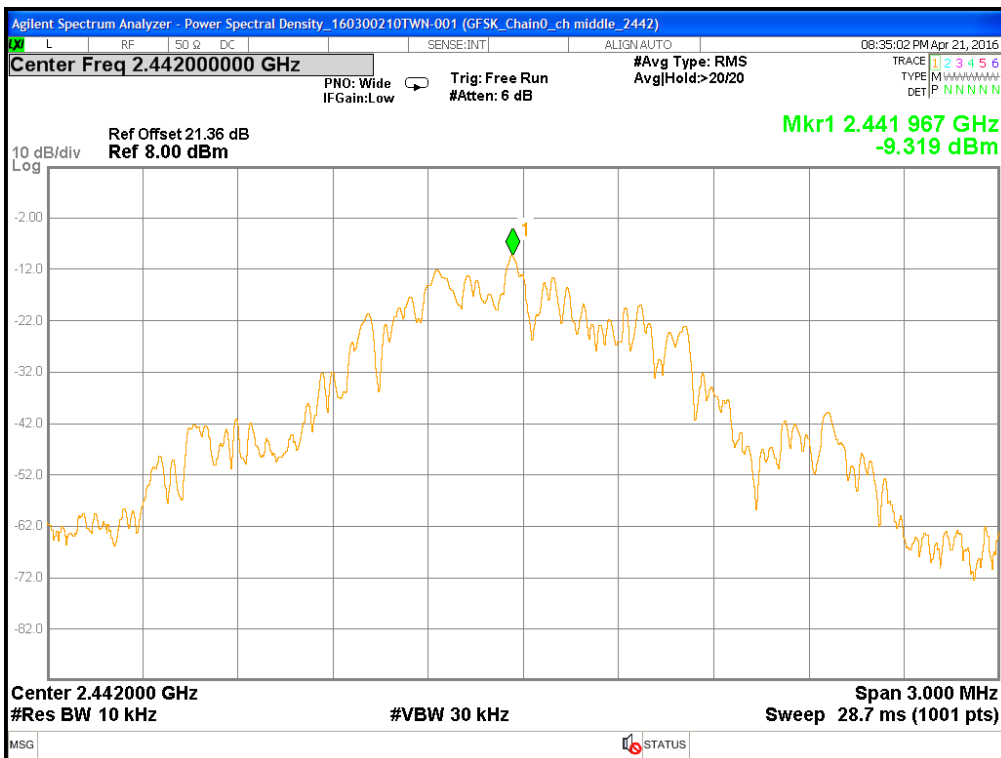

Chain0 : Power Spectral Density @ Ch High



6. Emissions In Non-Restricted Frequency Bands

6.1 Operating environment

Temperature:	20	°C
Relative Humidity:	55	%
Atmospheric Pressure	1008	hPa
Requirement	15.247(d)	

6.2 Limit for emissions in non-restricted frequency bands

The peak output power measured in any 100 kHz bandwidth outside of the authorized frequency band shall be attenuated by at least 20 dB relative to the maximum in-band peak PSD level in 100 kHz

6.3 Measuring instruments setting

Reference level measurement

Spectrum analyzer settings	
Spectrum Analyzer function	Setting
Detector	Peak
RBW	≥ 100 kHz
VBW	$\geq 3 \times$ RBW
Sweep	Auto couple
Trace	Max hold
Span	≥ 1.5 time 6dB bandwidth
Attenuation	Auto

Emission level measurement

Spectrum analyzer settings	
Spectrum Analyzer function	Setting
Detector	Peak
RBW	≥ 100 kHz
VBW	$\geq 3 \times$ RBW
Sweep	Auto couple
Trace	Max hold
Attenuation	Auto

6.4 Test procedure

1. The procedure was used in antenna-port conducted and connected to the spectrum analyzer.
2. Set instrument center frequency to center frequency
3. Use the parameter configured in clause 6.3 to measure
4. Use the peak marker function to determine the maximum amplitude level.

6.5 Test diagram

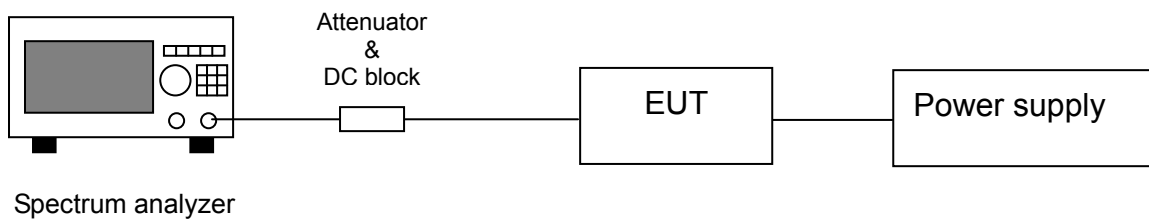

6.6 Test results

Chain0 : Conducted Spurious @ Ch Low

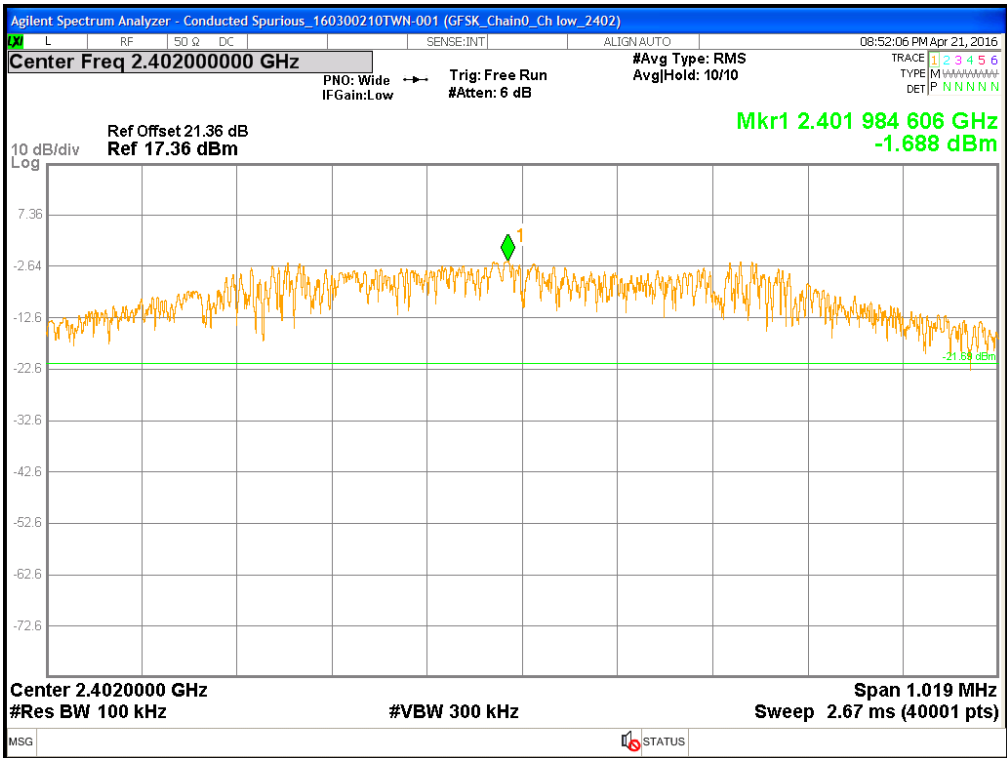

Chain0 : Conducted Spurious @ Ch Low

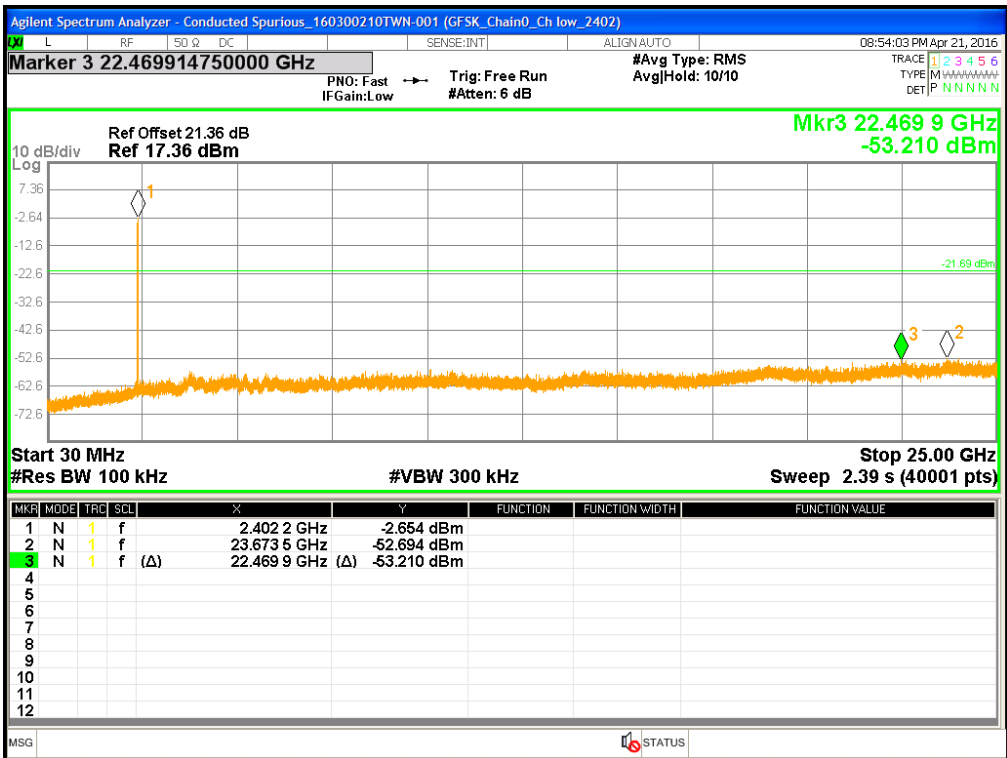

Chain0 : Conducted Spurious @ ch Middle

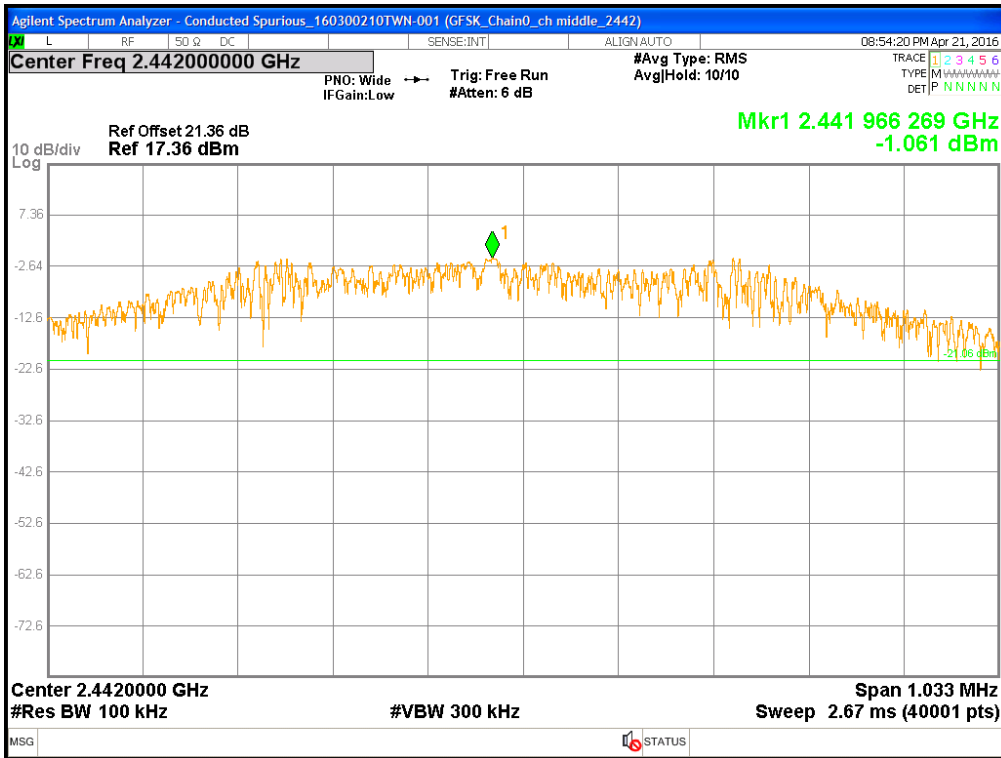

Chain0 : Conducted Spurious @ ch Middle

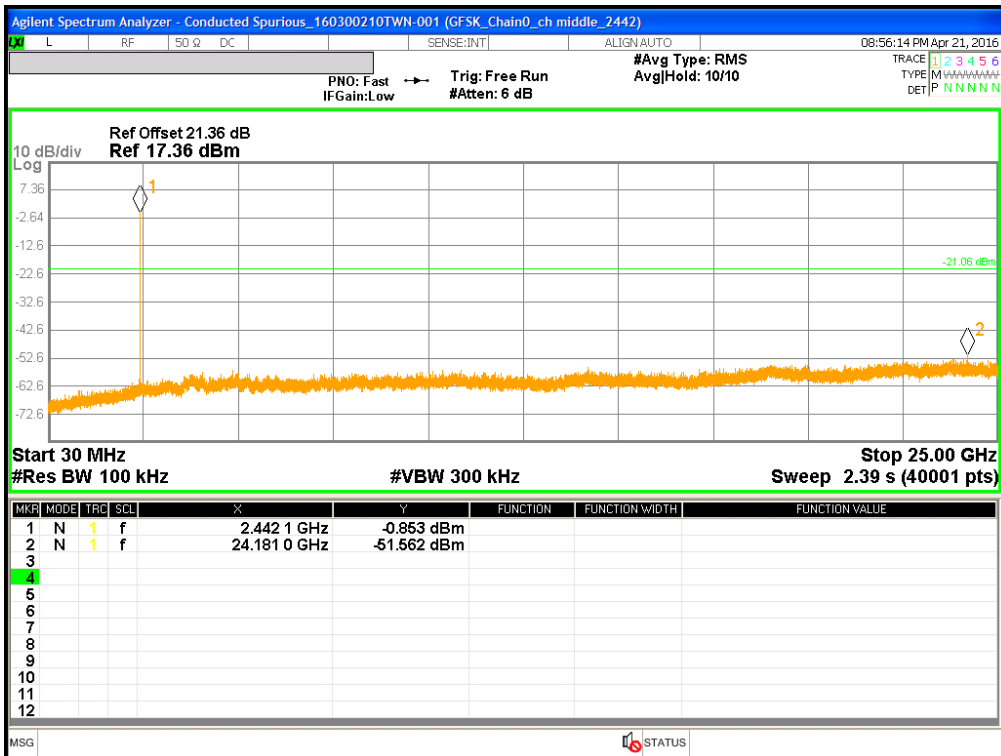

Chain0 : Conducted Spurious @ ch High

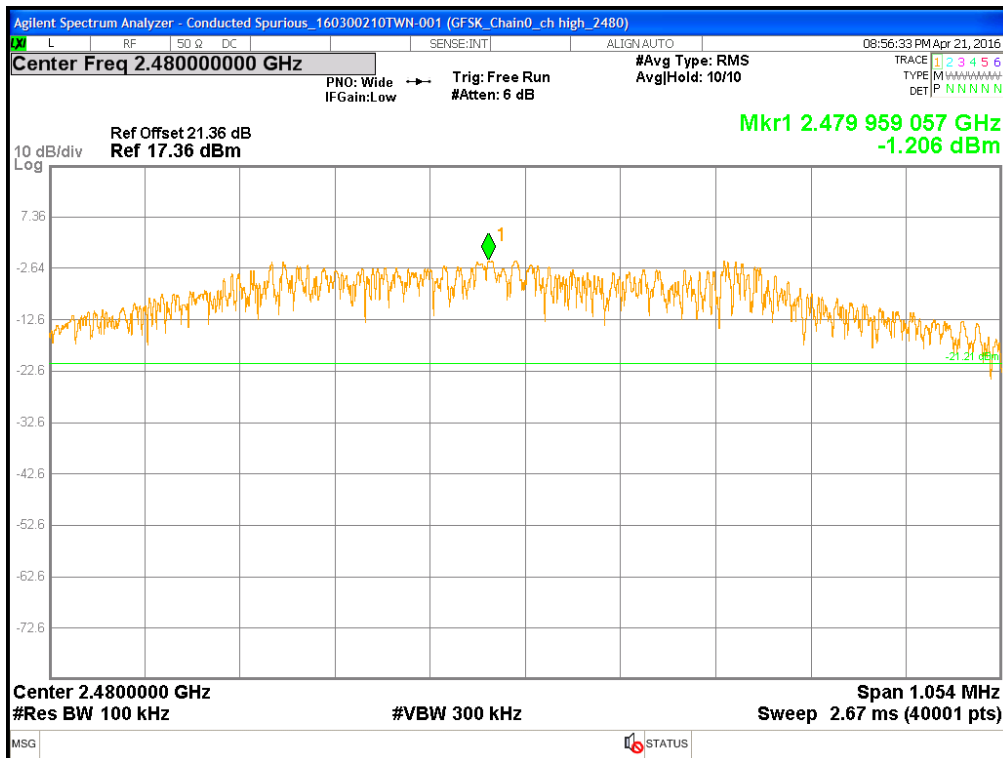

Chain0 : Conducted Spurious @ ch High

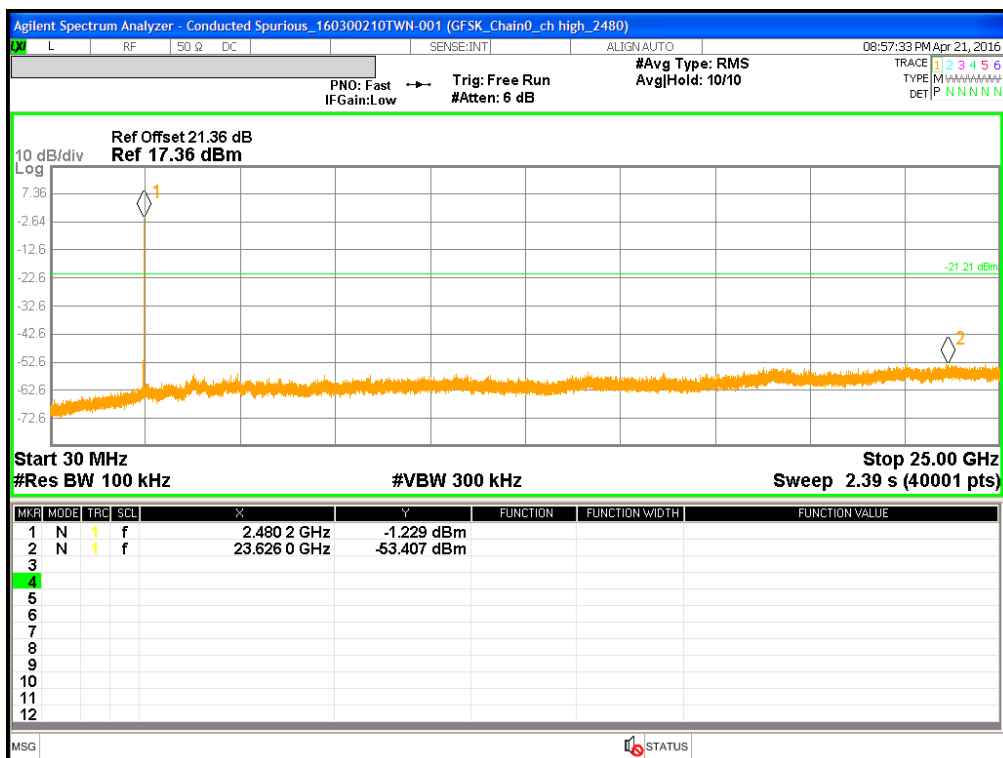

7. Emissions In Restricted Frequency Bands (Radiated emission measurements)

7.1 Operating environment

Temperature:	20	°C
Relative Humidity:	55	%
Atmospheric Pressure	1008	hPa
Requirement	15.247(d), 15.205, 15.209	

7.2 Limit for emission in restricted frequency bands (Radiated emission measurement)

Frequency (MHz)	Field Strength (microvolts/meter)	Measurement distance (meters)
0.009~0.490	2400/F(kHz)	300
0.490~1.705	2400/F(kHz)	30
1.705~30	30	30
30-88	100	3
88-216	150	3
216-960	200	3
Above 960	500	3

Remark:

1. In the above table, the tighter limit applies at the band edges.
2. Distance refers to the distance in meters between the measuring instrument antenna and the closed point of any part of the device or system

7.3 Measuring instrument setting

Below 1GHz measurement

Receiver settings	
Receiver function	Setting
Detector	QP
RBW	9-150 kHz ; 200-300 Hz 0.15-30 MHz; 9-10 kHz 30-1000 MHz; 100-120 kHz
VBW	$\geq 3 \times$ RBW
Sweep	Auto couple
Attenuation	Auto

Above 1GHz measurement

Spectrum analyzer settings	
Spectrum Analyzer function	Setting
Detector	Peak
RBW	1MHz
VBW	3MHz for Peak; 10Hz for Average
Sweep	Auto couple
Start Frequency	1GHz
Stop Frequency	Tenth harmonic
Attenuation	Auto

7.4 Test procedure

1. Configure the EUT according to ANSI C63.10: 2013 The EUT was placed on the top of the turntable 1.5 meter above ground for above 1GHz and placed on the top of the turntable 0.8 meter above ground for below 1GHz. The center of the receiving antenna mounted on the top of a height-variable antenna tower was placed 3 meters far away from the turntable.
2. Power on the EUT and all the companion devices. The turntable was rotated by 360 degree to find the position of the maximum emission level.
3. The height of the receiving antenna was varied between one meter and four meters above ground to find the maximum emission field strength of the both horizontal and vertical polarization
4. If find the frequencies above the limit or below within 3dB, the antenna tower was scan (from 1m to 4m) and then the turntable was rotated to find the maximum reading.
5. Set the test-receiver system to peak or CISPR quasi-peak detector with specified bandwidth under maximum hold mode.
6. For emissions above 1GHz, use 1MHz VBW and 3MHz RBW for peak reading. Then 1MHz RBW and 10Hz VBW for average reading in spectrum analyzer.
7. If the emissions level of the EUT in peak mode was 3dB lower than the average limit specified then testing will be stopped and peak values of the EUT will be reported. Otherwise, the emissions which do not have 3dB margin will be measured using the quasi-peak method for below 1GHz.
8. For testing above 1GHz, The emissions level of the EUT in peak mode was lower than average limit, then testing will be stopped and peak values of the EUT will be reported, otherwise, the emission will be measured in average mode again and reported.
9. In case the emission is lower than 30MHz, loop antenna has to be used for measurement and the recorded data should be quasi-peak measured by receiver.

7.5 Test configuration

7.5.1 Radiated emission from 9kHz to 30MHz uses Loop Antenna:

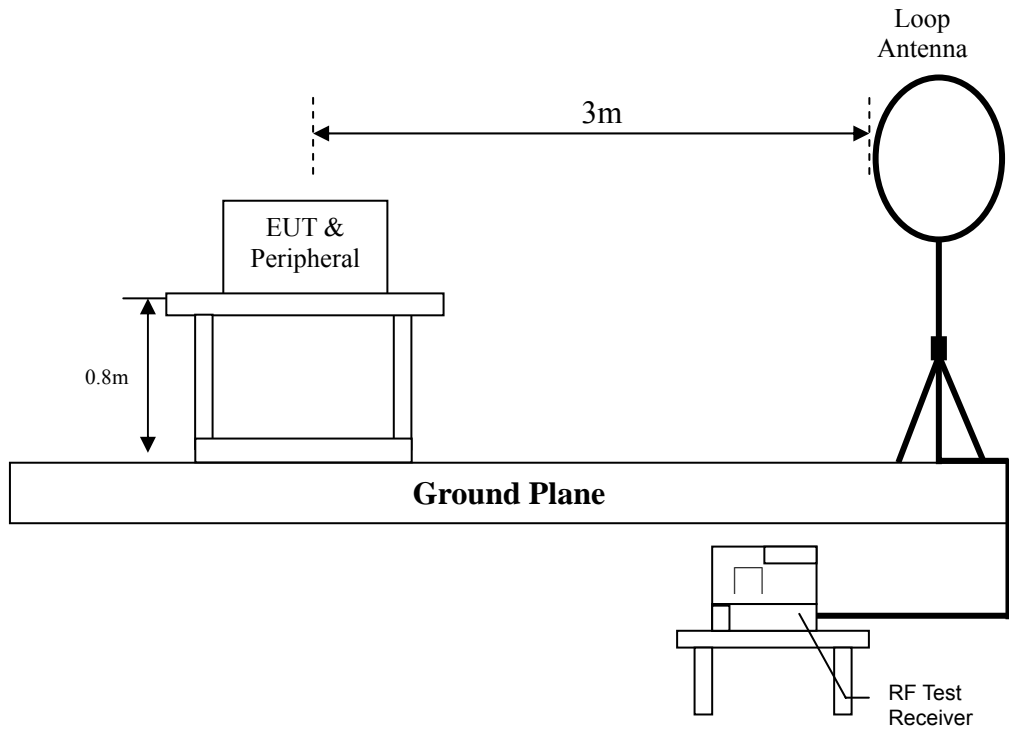

7.5.2 Radiated emission below 1GHz using Bilog Antenna

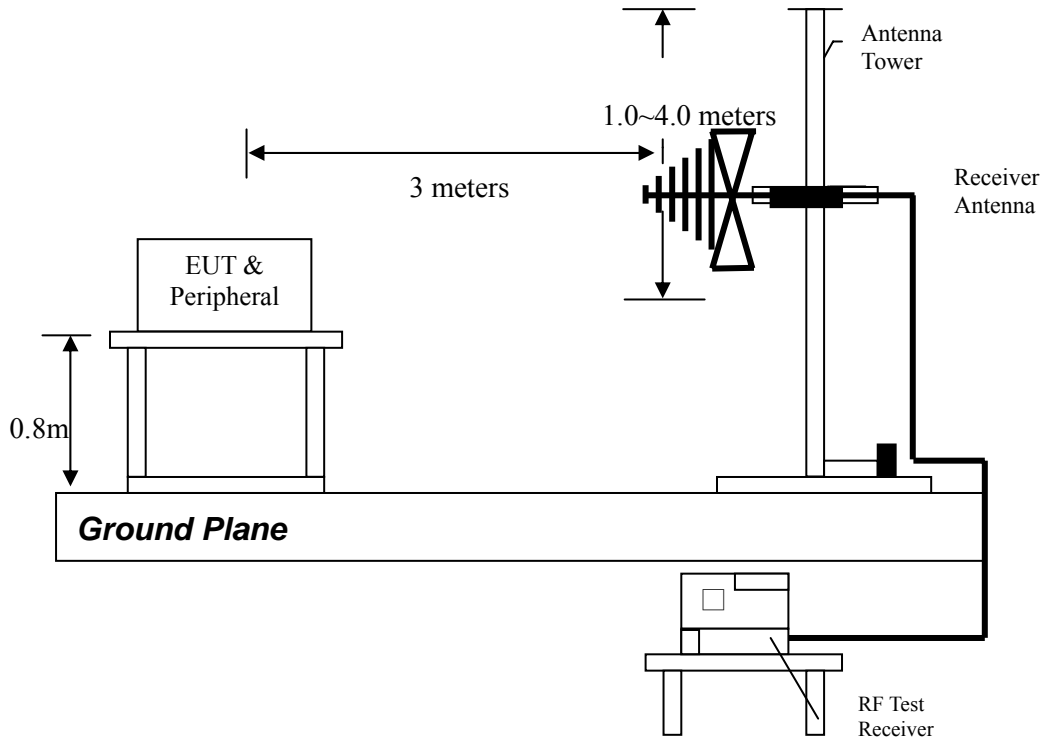

7.5.3 Radiated emission & above 1GHz using Horn Antenna

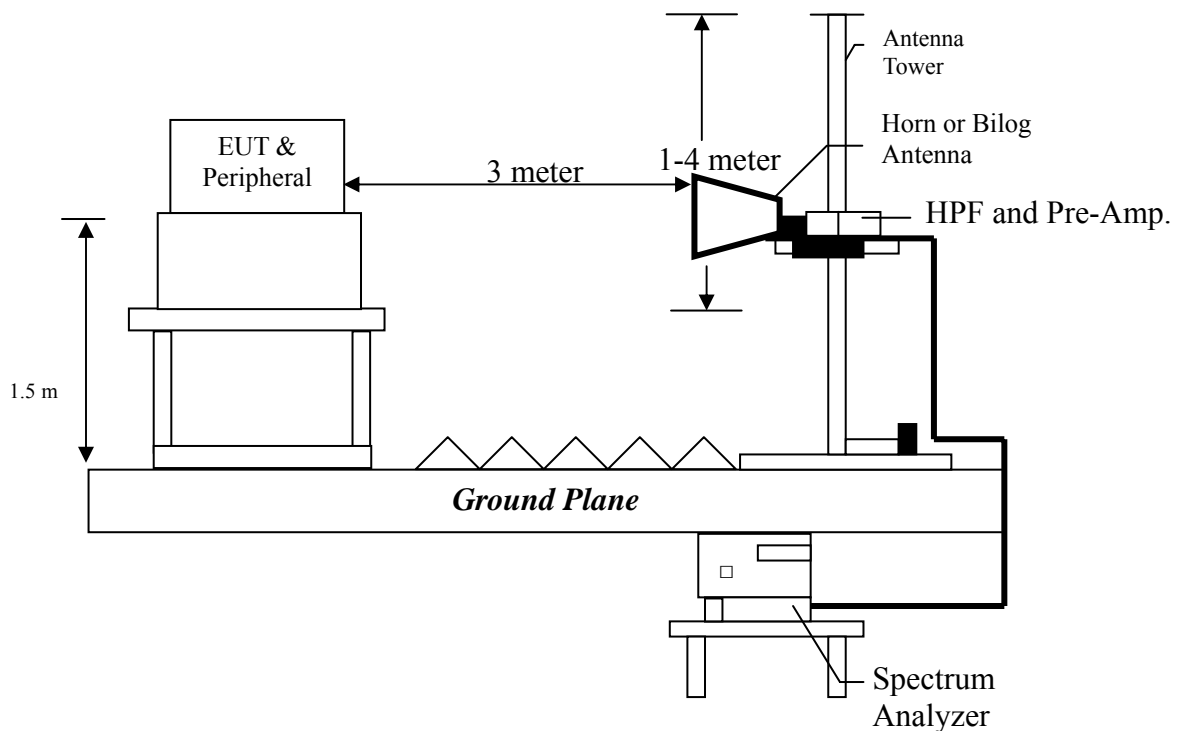

7.6 Test result

7.6.1 Measurement results: frequencies 9kHz to 30MHz

EUT : HURESAC-3XE-C
Test mode : TX mode High channel
Test Voltage : 120 Vac

Frequency (MHz)	Detection value	factor (dB/m)	Reading (dB μ V)	value (dB μ V/m)	Limit @ 3m (dB μ V/m)	Tolerance (dB)
0.02	QP	20.92	15.90	36.82	200.00	-163.19
0.03	QP	20.86	19.08	39.94	160.00	-120.06
0.05	QP	20.83	15.58	36.41	128.00	-91.59
0.07	QP	20.81	15.23	36.04	114.29	-78.25
0.11	QP	20.77	15.55	36.32	101.82	-65.50
0.15	QP	20.77	12.65	33.42	96.00	-62.58

Remark: Corr. Factor = Antenna Factor + Cable Loss

7.6.2 Measurement results: frequencies below 1 GHz

The test was performed on EUT under GFSK continuously transmitting mode. The worst case occurred at Tx Middle channel

EUT :HURESAC-3XE-C
Worst Case : GFSK at Tx Middle channel
Test Voltage : 120 Vac

Antenna Polariz. (V/H)	Freq. (MHz)	Receiver Detector	Corr. Factor (dB/m)	Reading (dBμV)	Corrected Level (dBμV/m)	Limit @ 3 m (dBμV/m)	Margin (dB)
Vertical	47.46	QP	16.97	25.06	29.76	40.00	-10.24
Vertical	142.52	QP	16.16	19.23	29.93	43.50	-13.57
Vertical	192.96	QP	13.94	15.67	32.87	43.50	-10.63
Vertical	288.02	QP	17.06	21.70	35.09	46.00	-10.91
Vertical	336.52	QP	18.38	16.75	32.73	46.00	-13.27
Vertical	528.58	QP	22.60	11.30	37.58	46.00	-8.42
Horizontal	142.52	QP	15.15	14.91	28.70	43.50	-14.80
Horizontal	194.90	QP	16.07	15.83	33.97	43.50	-9.53
Horizontal	216.24	QP	16.44	17.59	32.82	46.00	-13.18
Horizontal	239.52	QP	16.85	18.56	33.56	46.00	-12.44
Horizontal	288.02	QP	17.70	11.82	36.71	46.00	-9.29
Horizontal	334.58	QP	18.52	10.96	33.75	46.00	-12.25

Remark: Corr. Factor = Antenna Factor + Cable Loss

7.6.3 Measurement results: frequency above 1GHz

EUT :HURESAC-3XE-C
Test Voltage : 120Vac

Mode	Frequency	Spectrum	Ant.	Preamp.	Correction	Reading	Corrected	Limit	Margin
		Analyzer	Pol.	Gain	Factor		Reading	@ 3 m	
	(MHz)	Detector	(H/V)	(dB)	(dB/m)	(dBμV)	(dBμV/m)	(dBμV/m)	(dB)
Ch Low	3150	PK	V	39.85	-3.73	48.44	44.71	74.00	-29.29
	4804	PK	V	40.13	-0.10	41.89	41.79	74.00	-32.21
	3150	PK	H	39.85	-3.73	46.50	42.77	74.00	-31.23
	4804	PK	H	40.13	-0.10	41.06	40.96	74.00	-33.04
Ch Middle	3150	PK	V	39.85	-3.73	47.87	44.14	74.00	-29.86
	4884	PK	V	39.99	0.16	41.04	41.20	74.00	-32.80
	3150	PK	H	39.85	-3.73	47.47	43.74	74.00	-30.26
	4884	PK	H	39.99	0.16	41.49	41.65	74.00	-32.35
Ch High	3150	PK	V	39.85	-3.73	47.34	43.61	74.00	-30.39
	4960	PK	V	39.84	0.41	42.02	42.43	74.00	-31.57
	3150	PK	H	39.85	-3.73	45.33	41.60	74.00	-32.40
	4960	PK	H	39.84	0.41	41.16	41.57	74.00	-32.43

Remark: Correction Factor = Antenna Factor + Cable Loss + High Pass Filter Loss - Pre_Amplifier Gain

8. Emission On Band Edge

8.1 Operating environment

Temperature:	25	°C
Relative Humidity:	50	%
Atmospheric Pressure	1008	hPa
Requirement	15.247(d), 15.205,	

8.2 Measuring instrument setting

Spectrum analyzer settings	
Spectrum Analyzer function	Setting
Detector	Peak
RBW	1MHz
VBW	3MHz for Peak; 10Hz for Average
Sweep	Auto couple
Restrict bands	2310~2390MHz
	2483.5 ~2500MHz
Attenuation	Auto

8.3 Test procedure

The test procedure is the same as clause 7.4

8.4 Test results

Mode	Frequency (MHz)	Spectrum Analyzer Detector	Ant. Pol. (H/V)	Correction Factor (dB/m)	Reading (dBμV)	Corrected Reading (dBμV/m)	Limit @ 3 m (dBμV/m)	Margin (dB)	Restricted band (MHz)
BT4.0	2373.43	PK	V	33.77	19.48	53.25	74	-20.75	2310~2390
	2384.95	AV	V	33.83	7.74	41.57	54	-12.43	
	2498.91	PK	V	34.37	20.70	55.07	74	-18.93	2483.5~2500
	2483.50	AV	V	34.30	6.64	40.94	54	-13.06	
Remark: Correction Factor = Antenna Factor + Cable Loss									

Chain0 : 20dBc @ Ch Low

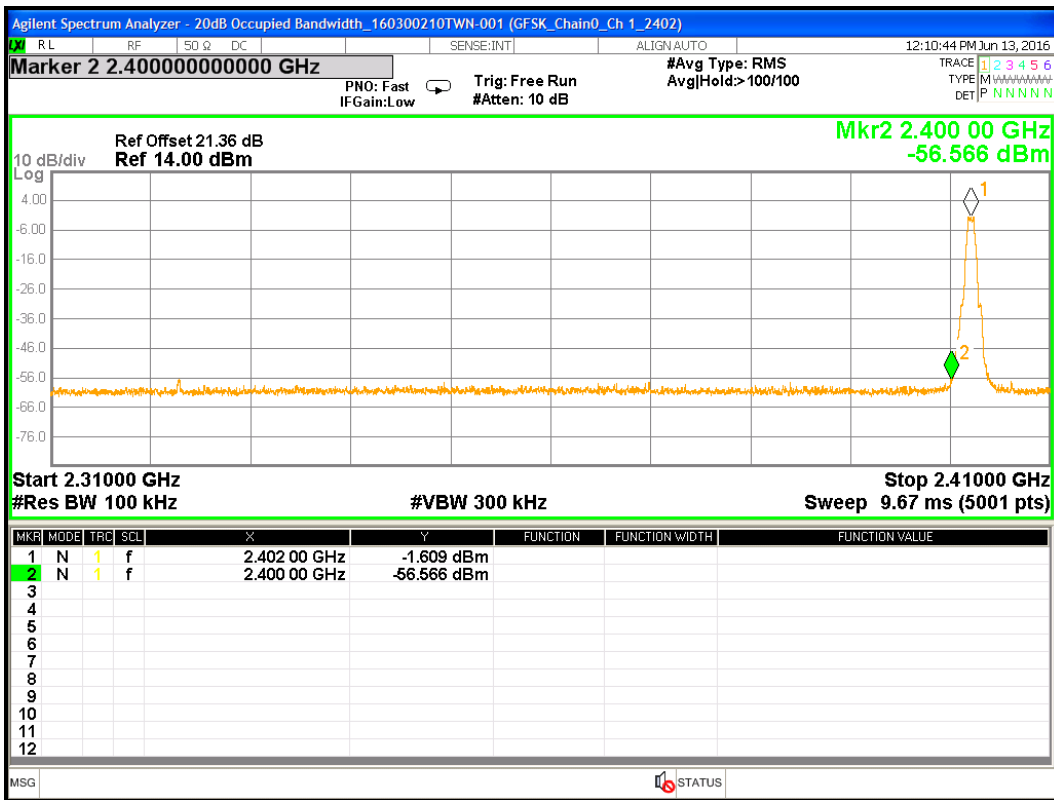

Chain0 : 20dBc @ ch High

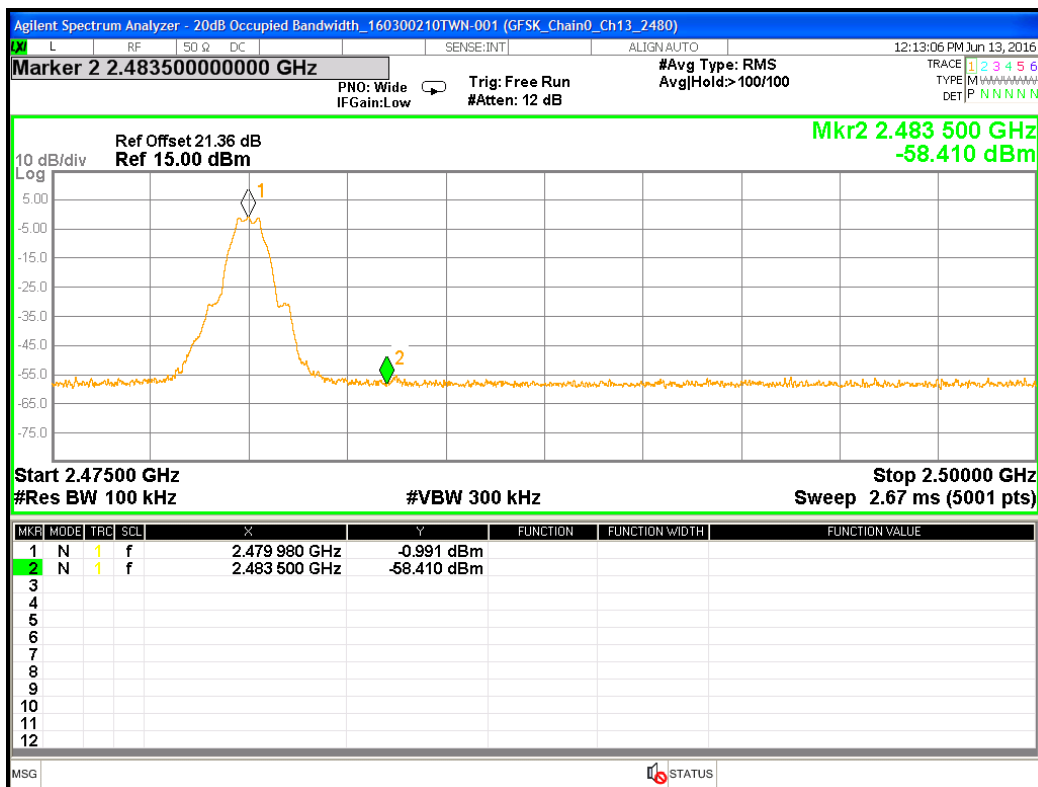

Chain0 : Band Edge @ GFSK mode Low Channel PK

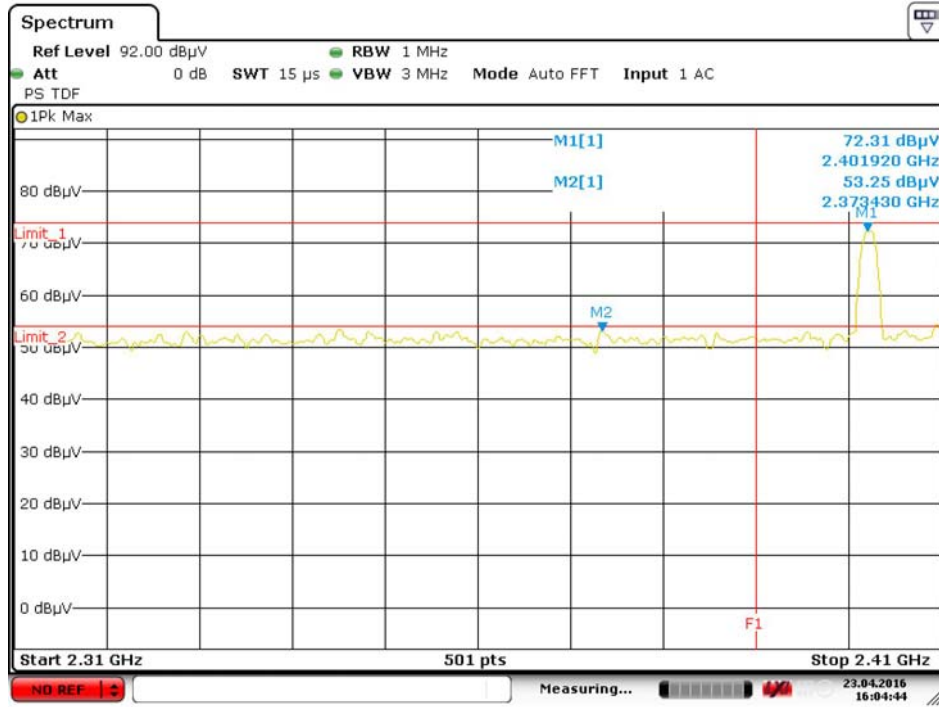

Date: 23.APR.2016 16:04:44

Chain0 : Band Edge @ GFSK mode Low Channel AV

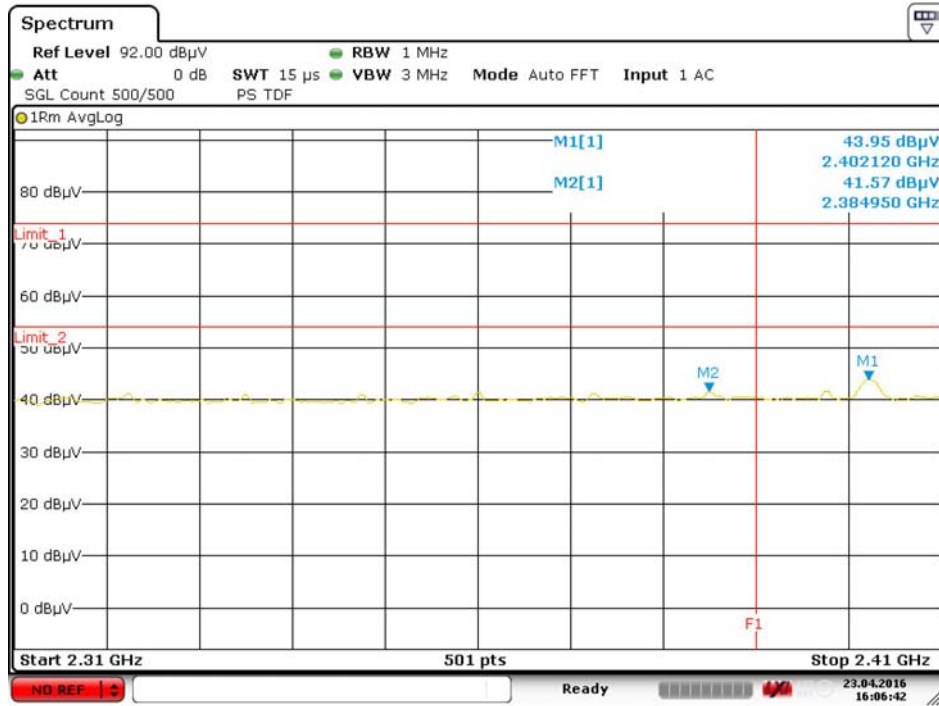

Date: 23.APR.2016 16:06:43

Chain0 : Band Edge @ GFSK mode High Channel PK

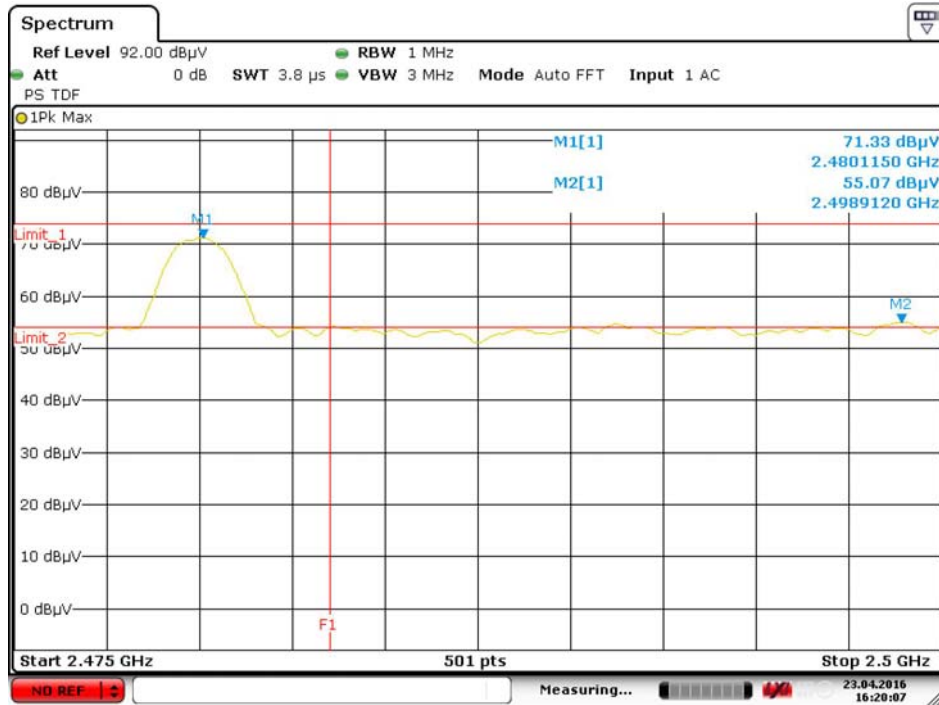

Date: 23.APR.2016 16:20:07

Chain0 : Band Edge @ GFSK mode High Channel AV

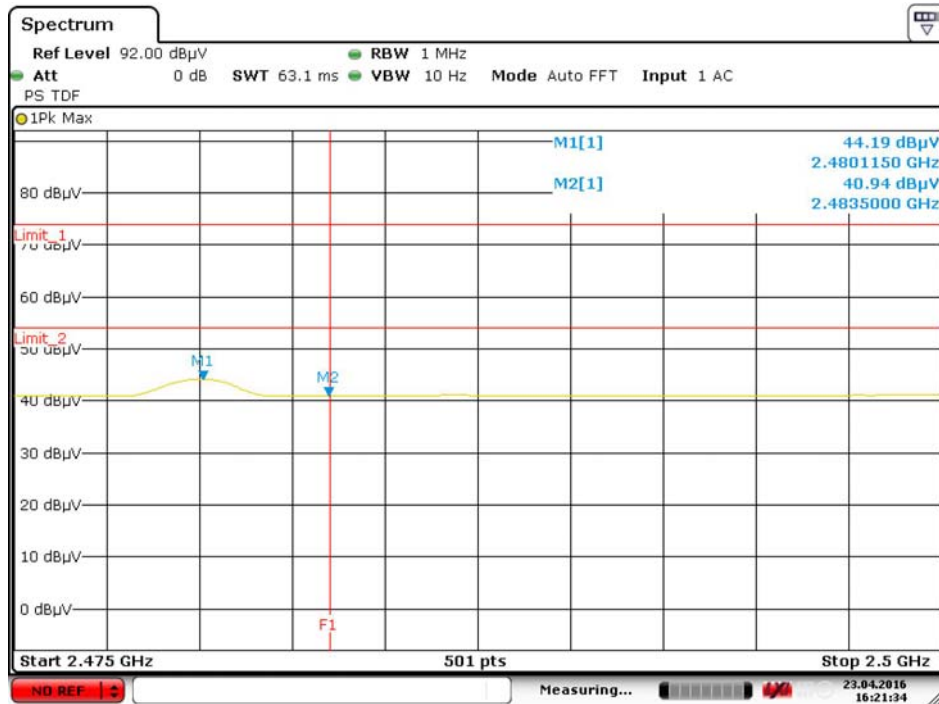

Date: 23.APR.2016 16:21:35

9. AC Power Line Conducted Emission

9.1 Operating environment

Temperature:	20	°C
Relative Humidity:	58	%
Atmospheric Pressure	1009	hPa
Requirement	15.207	

9.2 Limit for AC power line conducted emission

Freq. (MHz)	Conducted Limit (dBuV)	
	Q.P.	Ave.
0.15~0.50	66 – 56*	56 – 46*
0.50~5.00	56	46
5.00~30.0	60	50

9.3 Measuring instrument setting

Receiver settings	
Receiver function	Setting
Detector	QP
Start frequency	0.15MHz
Stop frequency	30MHz
IF bandwidth	9 kHz
Attenuation	10dB

9.4 Test procedure

1. Configure the EUT according to ANSI C63.10: 2013. The EUT or host of EHT has to be placed 0.4 meter far from the conducting wall of the shielding room and at least 80 centimeters from any other grounded conducting surface.
2. Connect EUT or host of EUT to the power mains through a line impedance stabilization network.

3. All the companion devices are connected to the other LISN. The LISN should provide 50U_h/50ohms coupling impedance.
4. The frequency range from 150 kHz to 30MHz was searched
5. Set the test-receiver system to peak detector and specified bandwidth with maximum hold mode.
6. The measurement has to be done between each power line and ground at the power terminal.

9.5 Test diagram

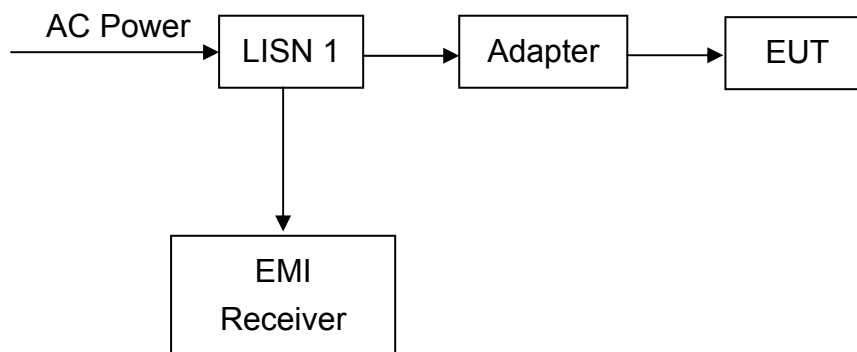

Note: The EUT was tested while in normal communication mode.

9.6 Test results

Phase : Line
EUT : HURESAC-3XE-C
Test Condition : TX mode

Frequency (MHz)	Corr. Factor (dB)	Level Qp (dBuV)	Limit Qp (dBuV)	Level Av (dBuV)	Limit Av (dBuV)	Margin (dB)	
						Qp	Av
0.154	9.74	0.00	0.00	0.00	0.00	0.00	0.00
0.154	9.74	49.55	65.78	39.94	55.78	-16.23	-15.84
0.204	9.74	43.56	63.45	25.27	53.45	-19.88	-28.17
0.256	9.74	36.87	61.56	18.95	51.56	-24.69	-32.60
0.419	9.73	33.90	57.46	30.43	47.46	-23.56	-17.04
0.529	9.74	39.21	56.00	35.12	46.00	-16.79	-10.88
14.288	9.88	34.63	60.00	29.87	50.00	-25.37	-20.13

Remark:

1. Corr. Factor (dB) = LISN Factor (dB) + Cable Loss (dB)
2. Over Limit (dB) = Level (dBuV) – Limit (dBuV)

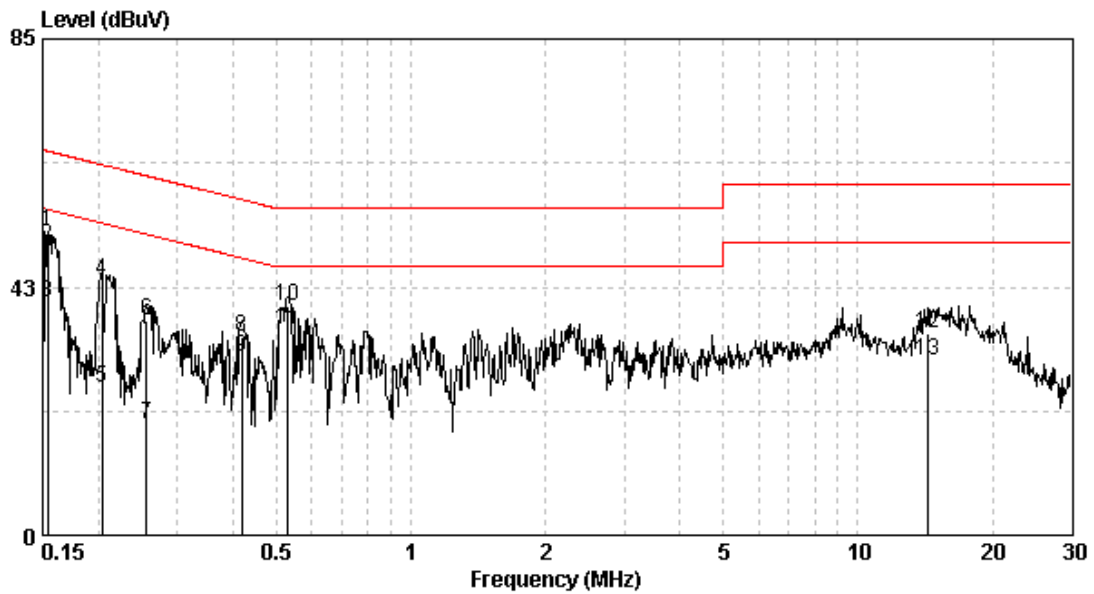

Phase : Neutral
EUT : HURESAC-3XE-C
Test Condition : TX mode

Frequency (MHz)	Corr. Factor (dB)	Level Qp (dBuV)	Limit Qp (dBuV)	Level Av (dBuV)	Limit Av (dBuV)	Over limit (dB) Qp	Over limit (dB) Av
0.155	0.01	20.02	65.74	1.52	55.74	-45.72	-54.22
0.195	0.01	28.25	63.80	21.85	53.80	-35.54	-31.95
0.651	0.01	29.67	56.00	26.94	46.00	-26.33	-19.06
7.407	0.38	38.66	60.00	29.21	50.00	-21.34	-20.79
21.946	0.74	49.01	60.00	42.17	50.00	-10.99	-7.83
22.535	0.76	43.38	60.00	33.40	50.00	-16.62	-16.60

Remark:

1. Corr. Factor (dB) = LISN Factor (dB) + Cable Loss (dB)
2. Over Limit (dB) = Level (dBuV) – Limit (dBuV)

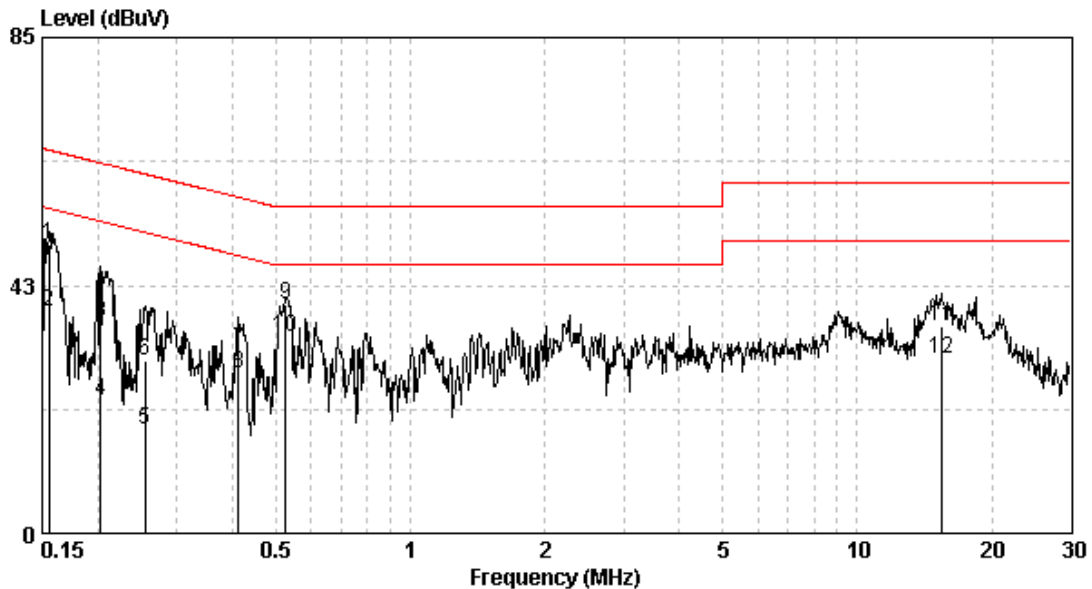

Appendix A: Test equipment list

Equipment	Brand	Model No.	Serial No.	Calibration Date	Next Calibration Date
ESCI EMI Test Receiver	Rohde & Schwarz	ESCI	100018	2015/12/02	2016/11/30
Spectrum Analyzer	Rohde & Schwarz	FSP30	100137	2015/08/18	2016/08/16
Horn Antenna (1-18G)	SHWARZBECK	BBHA 9120 D	9120D-456	2014/08/29	2017/08/27
Horn Antenna (14-42G)	SHWARZBECK	BBHA 9170	BBHA9170159	2014/09/16	2017/09/14
Broadband Antenna	SHWARZBECK	VULB 9168	9168-172	2013/08/08	2016/08/06
Pre-Amplifier	EMC Co.	EMC12635SE	980205	2015/10/7	2016/10/05
Pre-Amplifier	MITEQ	JS4-26004000-- 27-8A	828825	2015/09/15	2016/09/13
Power Meter	Anritsu	ML2495A	0844001	2015/11/11	2016/11/09
Power Sensor	Anritsu	MA2411B	0738452	2015/11/11	2016/11/09
Two-Line V-Network	Rohde & Schwarz	ENV216	101159	2015/06/08	2016/06/06
Artificial Mains Network (LISN)	Schaffner	MN2050D	1586	2015/05/27	2016/05/25
CON-1 Cable	SUHNER	BNC / RG-58	1521946	2015/05/09	2016/05/07
Test software	Audix	e3	4.2004-1-12k	NCR	NCR
Signal Analyzer	Agilent	N9030A	MY51380492	2015/09/21	2016/09/19
966-2(A) Cable 9kHz~26.5GHz	SUHNER	SMA / EX 100	N/A	2015/05/06	2016/05/05
966-2(B) Cable 9kHz~26.5GHz	SUHNER	SMA / SUCOFLEX 104P	CB0005	2015/05/06	2016/05/04

Equipment	Brand	Model No.	Serial No.	Calibration Date	Next Calibration Date
RF Cable 9kHz~26.5GHz	SUHNER	SUCOFLEX 102	CB0006	2015/05/06	2016/05/05
966-2_3m Semi-Anechoic Chamber	966_2	CEM-966_2	N/A	2016/02/24	2017/02/22
High Pass Filter	Reactel	7HS-3G/18G-S 11	N/A	2015/06/06	2016/06/04
Active Loop Antenna	SCHWARZBECK MESS-ELEKTRO NIC	FMZB1519	1519-067	2016/03/03	2017/03/02
EMI Test Receiver	Rohde & Schwarz	ESR-7	101232	2015/12/02	2016/11/30
Test software	ADT	Radiated test system	7.5.14	NCR	NCR

Note: No Calibration Required (NCR).

Appendix B: Measurement Uncertainty

This uncertainty represents an expanded uncertainty expressed at approximately the 95 % confidence level using a coverage factor of $k=2$.

Item	Uncertainty
Vertically polarized radiated disturbances from 30MHz~1GHz in a semi-anechoic chamber at a distance of 3m	5.14 dB
Horizontally polarized radiated disturbances from 30MHz~1GHz in a semi-anechoic chamber at a distance of 3m	5.22 dB
Vertically polarized Radiated disturbances from 1GHz~18GHz in a semi-anechoic chamber at a distance of 3m	3.64 dB
Horizontally polarized Radiated disturbances from 1GHz~18GHz in a semi-anechoic chamber at a distance of 3m	3.64 dB
Vertically polarized Radiated disturbances from 18GHz~40GHz in a semi-anechoic chamber at a distance of 3m	2.7 dB
Horizontally polarized Radiated disturbances from 18GHz~40GHz in a semi-anechoic chamber at a distance of 3m	2.7 dB
Radiated disturbances from 9kHz~30MHz in a semi-anechoic chamber at a distance of 3m	3.53 dB
Emission on the Band Edge Test	3.64 dB
Minimum 6 dB Bandwidth	0.85 dB
Maximum Peak Conducted Output Power	0.42 dB
Power Spectral Density	0.85 dB
Emissions In Non-Restricted Frequency Bands	0.85 dB
AC Power Line Conducted Emission	2.47 dB