

Blackboard VR4101 Vending Reader Description of Circuitry

The VR4101 Vending Reader supports both mag-stripe and contactless cards. Readers currently offered by Blackboard have all been based on the mag-stripe technology only. With the need for additional security, a reader with contactless capabilities was required. The VR4101 uses Near Field Communications (NFC) to read FeliCa™ contactless cards.

The VR4101 contains 4 circuit boards. They consist of the main processor board which uses a Marvell PXA310 microprocessor, a Secure microcontroller board which uses the Dallas Semiconductor DS5250, an I/O board which contains a DC/DC Switcher and connectors which interface to a network and the Vending machine MDB bus, and an LCD board which contains the circuitry for the 802.11 b/g and circuitry for reading the contactless cards.

802.11 b/g Circuitry

The Blackboard Vending Reader, model VR4101 uses an integrated solution System-in-Package (SIP) device for providing 802.11 b/g WLAN capabilities. The W2SW0001C-T is controlled by a PXA310 processor through an industry standard Secure Digital Input Output (SDIO) interface. The company manufacturing the device is Wi2Wi and the part number is W2SW0001C-T.



The device integrates all the circuitry necessary for wireless in a single package with the exception of an external antenna. The W2SW0001C-T is a complete system-in-package which includes the Marvell 88W8686 802.11b/g chip set, crystal, power amplifier and filter components. The internal crystal oscillator operates at 26 MHz frequency (frequency stability +/- 20 ppm) and requires no external clock source. A pin provides the antenna interface with 50 Ohm impedance.

A block diagram is shown below:

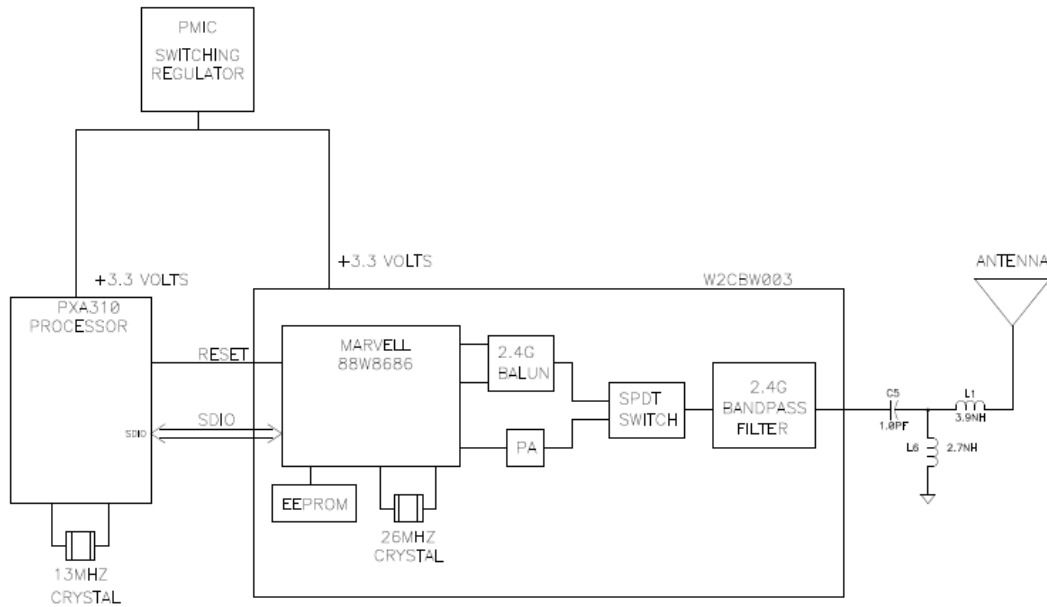

The transceiver uses Orthogonal Frequency Division Multiplexing (OFDM) and Complementary Code Keying (CCK) modulation for the 802.11b/g. The antenna is a surface mount chip antenna manufactured by Fractus, part number FR05-S1-N-0-00.1. The Fractus antenna has a gain of approximately 2.0 dBi.

13.56 MHz Circuitry

The VR4101 Vending Reader supports Near Field Communication (NFC) in the unlicensed radio frequency ISM band of 13.56 MHz. The reader operates in the passive communication mode and supports ISO 14443A/MIFARE® and FeliCa™ contactless cards.

The VR4101 uses the PN532 from NXP. This device has an integrated transceiver module for contactless communication and is controlled by an embedded 80C51 microcontroller core. The PN532 is controlled by software from a MAXIM DS5250 Secure micro-controller. The two devices communicate over a serial UART.

A block diagram of the circuitry is shown below:

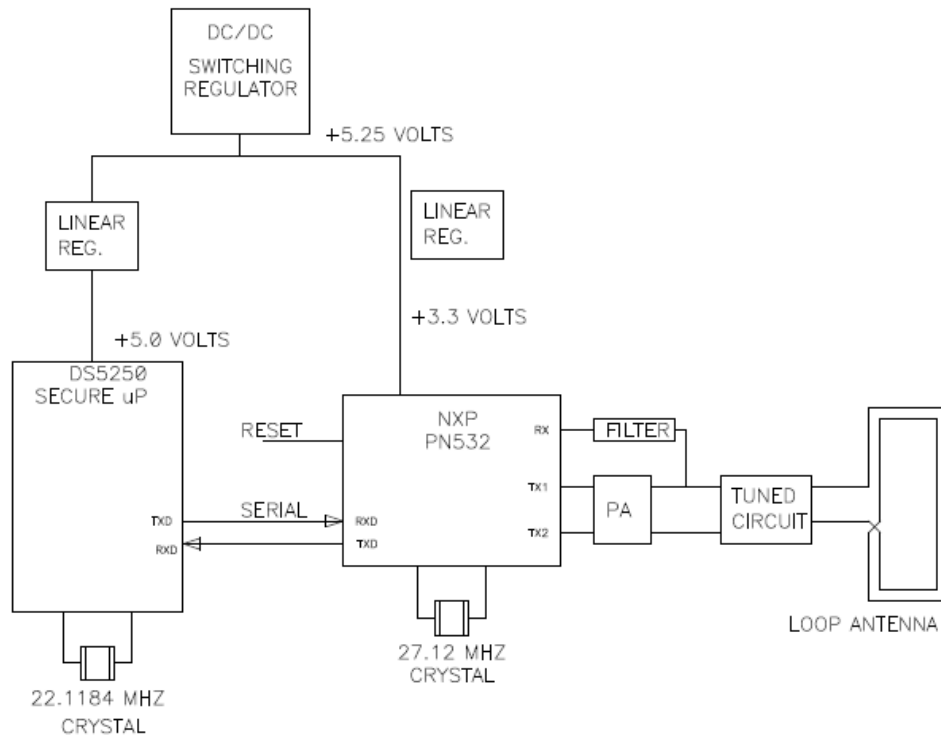

Circuit Operation

The PN532 uses an external crystal for a clock source. The crystal has a resonance frequency of 27.12 MHz. This clock is divided to generate the 13.56MHz carrier frequency.

The signal deliver on pin TX1 and pin TX2 is the 13.56 MHz energy carrier modulated by an envelope signal. The data signal on the 13.56 MHz carrier uses 8% - 14% Amplitude-Shift-Keying (ASK) and is Manchester encoded at a baud rate of 212 Kbits/second.

The power amplifier circuit consists of two symmetric emitter amplifiers. Each transistor is used as a switch. The TX1 and TX2 output pins of the PN532 generate digital signals which drive the base of each transistor through a base resistor. The resistor limits the current into the base. An AC-decoupling inductor is connected to the collector of each transistor and the power supply. The AC-decoupling inductor and the capacitor that shunts the transistor collector to ground interact as a 13.56 MHz oscillator. A resistor and capacitor connect the emitter of the transistor to ground. The resistor value controls the gain and limits the current.

The series inductor connected between the transistor collector and the capacitor to ground, provide an EMC filter. The series resistor connected directly to the loop antenna is used to regulate the quality factor of the antenna. The capacitors and the resistors are used to achieve the required 13.56 MHz resonance frequency to achieve a quality factor for appropriate signal shaping according to ISO/IEC 14443.

The loop antenna is integrated in the PWB and was designed to have maximum area within the mechanical constraints of the reader form factor. The dimensions of the antenna are 2.3" x 1.2". The read range is approximately 2 inches.

The signal to the receiver is AC-coupled and filtered at the RX pin of the PN532.