



M. Flom Associates, Inc.
International Compliance Testing Laboratory
3356 N. San Marcos Place, Suite 107
Chandler, AZ 85225
toll-free: (866) 311-3268
fax: (480) 926-3598
<http://www.mflom.com>
info@mflom.com

Date of Report: August 20, 2005
Date of Submission: September 20, 2005

Federal Communications Commission
Via: Electronic Filing

Attention: Authorization & Evaluation Division

Applicant: Blackboard, Inc.
Equipment: LWI30XX
FCC ID: TMELWI30XX001
FCC Rules: 15.249, Modular

Gentlemen:

On behalf of the Applicant, enclosed please find Application Form 731, Engineering Test Report and all pertinent documentation, the whole for approval of the referenced equipment as shown.

Filing fees are attached.

We trust the same is in order. Should you need any further information, kindly contact the writer who is authorized to act as agent.

Sincerely yours,

David E. Lee, Quality Assurance Manager

enclosure(s)
cc: Applicant
DEL/del

M. Flom Associates, Inc.
3356 N. San Marcos Place, Suite 107
Chandler, Arizona 85225-7176
(480) 926-3100 phone, fax (480) 926-3598

FCC ID: TMELWI30XX001
MFA p0580010, d0580034



M. Flom Associates, Inc.
International Compliance Testing Laboratory
3356 N. San Marcos Place, Suite 107
Chandler, AZ 85225
toll-free: (866) 311-3268
fax: (480) 926-3598
<http://www.mflom.com>
info@mflom.com

Transmitter Certification

of

FCC ID: TMELWI30XX001
Model: LWI30XX

to

Federal Communications Commission

Rule Part 15.249, Modular Approval

Date of report: August 20, 2005

On the Behalf of the Applicant:

Blackboard, Inc.

At the Request of:

P.O. 05-01014

Blackboard, Inc.
22601 North 19th Ave, Suite 200
Phoenix, AZ 85027

Attention of:

Tom Kuestersteffen
623-476-1263
email: tkuestersteffen@blackboard.com
and/or Tim Mattson
623-476-1400

Sincerely yours,

David E. Lee, Quality Assurance Manager



List Of Exhibits
(FCC **Certification** (Transmitters) - Revised 9/28/98)

Applicant: Blackboard, Inc.

FCC ID: TMELWI30XX001

By Applicant:

1. Letter Of Authorization
2. Identification Drawings
 - Label
 - Location of Label
 - Compliance Statement
 - Location of Compliance Statement
3. Documentation: 2.1033(B)
 - (3) User Manual
 - (4) Operational Description
 - (5) Block Diagram
 - (5) Schematic Diagram
 - (7) Photographs
 - Block Diagram
 - Active Devices

By M.F.A. Inc.

- A. Testimonial & Statement of Certification

The Applicant has been cautioned as to the following:

15.21 Information to User.

The users manual or instruction manual for an intentional radiator shall caution the user that changes or modifications not expressly approved by the party responsible for compliance could void the user's authority to operate the equipment.

15.27(a) Special Accessories.

Equipment marketed to a consumer must be capable of complying with the necessary regulations in the configuration in which the equipment is marketed. Where special accessories, such as shielded cables and/or special connectors are required to enable an unintentional or intentional radiator to comply with the emission limits in this part, the equipment must be marketed with, i.e. shipped and sold with, those special accessories. However, in lieu of shipping or packaging the special accessories with the unintentional or intentional radiator, the responsible party may employ other methods of ensuring that the special accessories are provided to the consumer, without additional charge.

Information detailing any alternative method used to supply the special accessories for a grant of equipment authorization or retained in the verification records, as appropriate. The party responsible for the equipment, as detailed in § 2.909 of this chapter, shall ensure that these special accessories are provided with the equipment. The instruction manual for such devices shall include appropriate instructions on the first page of text concerned with the installation of the device that these special accessories must be used with the device. It is the responsibility of the user to use the needed special accessories supplied with the equipment.

Table Of Contents

Rule	Description	Page
	Test Report	1
	Standard Test Conditions and Engineering Practices	3
2.1033(c)	General Information Required	4
2.1046(a)	RF Power Output (Radiated)	6
2.1053(a)	Field Strength of Spurious Radiation	7
2.1049(c)(1)	Emission Masks (Occupied Bandwidth)	15
15.207	A/C Powerline Conducted Emissions	23
2.202(g)	Necessary Bandwidth and Emission Bandwidth	27

Required information per ISO/IEC Guide 25-1990, paragraph 13.2:

a) **Test Report**

b) Laboratory: M. Flom Associates, Inc.
(FCC: 31040/SIT) 3356 N. San Marcos Place, Suite 107
(Canada: IC 2044) Chandler, AZ 85225

c) Report Number: d0580034

d) Client: Blackboard, Inc.
22601 North 19th Ave, Suite 200
Phoenix, AZ 85027

e) Identification: LWI30XX
FCC ID: TMELWI30XX001
Description: 2.4GHz Transceiver

f) EUT Condition: Not required unless specified in individual tests.

g) Report Date: August 20, 2005
EUT Received: August 15, 2005

h, j, k): As indicated in individual tests.

i) Sampling method: No sampling procedure used.

l) Uncertainty: In accordance with MFA internal quality manual.

m) Supervised by:



David E. Lee, Quality Assurance Manager

n) Results: The results presented in this report relate only to the item tested.

o) Reproduction: This report must not be reproduced, except in full, without written permission from this laboratory.

Sub-part
2.1033(b):

Test and Measurement Data

All tests and measurement data shown were performed in accordance with FCC Rules and Regulations, Volume II; Part 2, Sub-part J, Sections 2.1031, 2.1033, 2.1035, 2.1041, 2.1043, 2.1045, and the following individual Parts:

_____	15.209	Radiated emission limits; general requirements
_____	15.211	Tunnel radio systems
_____	15.213	Cable locating equipment
_____	15.214	Cordless telephones
_____	15.217	Operation in the band 160-190 kHz
_____	15.219	Operation in the band 510-1705 kHz
_____	15.221	Operation in the band 525-1705 kHz (leaky coax)
_____	15.223	Operation in the band 1.705-10 MHz
_____	15.225	Operation in the band 13.553-13.567 MHz
_____	15.227	Operation in the band 26-27.28 MHz (remote control)
_____	15.229	Operation in the band 40.66-40.70 MHz
_____	15.231	Periodic operation in the band 40.66-40.70 MHz and above 70 MHz
_____	15.233	Operation within the bands 43.71-44.49, 46.60-46.98 MHz 48.75-49.51 MHz and 49.66-50.0 MHz
_____	15.235	Operation within the band 49.82-49.90 MHz
_____	15.237	Operation within the bands 72.0-73.0 MHz, 74.6-74.8 MHz and 75.2-76.0 MHz (auditory assistance)
_____	15.239	Operation in band 88-108 MHz
_____	15.241	Operation in the band 174-216 MHz (biomedical)
_____	15.243	Operation in the band 890-940 MHz (materials)
_____	15.245	Operation within the bands 902-928 MHz, 2435-2465 MHz, 5785-5815 MHz, 10500-10550 MHz, and 24075-24175 MHz (filed disturbance sensors)
_____	15.247	Operation within bands 902-928 MHz, 2400-2483.5 MHz, and 5725-5850 MHz (spread spectrum)
X _____	15.249	Operation within the bands 902-928 MHz, 2400-2483.5 MHz, 5725-5875 MHz, and 24.0- 24.25 GHz
_____	15.251	Operation within the bands 2.9-3.26 GHz, 3.267-3.332 GHz, 3.339-3.3458 GHz, and 3.358- 3.6 GHz (vehicle identification systems)
_____	15.321	Specific requirements for asynchronous devices operating in the 1910-1920 MHz and 2390- 2400 MHz bands (Unlicensed PCS)
_____	15.323	Specific requirements for isochronous devices operating in the 1920-1930 MHz sub-band (Unlicensed PCS)

Standard Test Conditions and Engineering Practices

Except as noted herein, the following conditions and procedures were observed during the testing:

In accordance with ANSI C63.4-1992/2000, section 6.1.9, and unless otherwise indicated in the specific measurement results, the ambient temperature of the actual EUT was maintained within the range of 10° to 40°C (50° to 104 °F) unless the particular equipment requirements specify testing over a different temperature range. Also, unless otherwise indicated, the humidity levels were in the range of 10% to 90% relative humidity.

Prior to testing, the EUT was tuned up in accordance with the manufacturer's alignment procedures. All external gain controls were maintained at the position of maximum and/or optimum gain throughout the testing.

Measurement results, unless otherwise noted, are worst-case measurements.



A2LA

"A2LA has accredited M. Flom Associates, Inc. Chandler, AZ for technical competence in the field of Electrical Testing. The accreditation covers the specific tests and types of tests listed on the agreed scope of accreditation. This laboratory meets the requirements of ISO/IEC 17025 - 1999 'General Requirements for the Competence of Testing and Calibration Laboratories' and any additional program requirements in the identified field of testing."

Certificate Number: **2152-01**

List Of General Information Required For Certification

In Accordance with FCC Rules and Regulations,
Volume II, Part 2 and to 15.249, Modular

Sub-Part 2.1033

(c)(1): **Name and Address of Applicant:**

Blackboard, Inc.
22601 North 19th Ave, Suite 200
Phoenix, AZ 85027

Manufacturer:

Applicant

(c)(2): **FCC ID:** TMELWI30XX001

Model Number: LWI30XX

(c)(3): **Instruction Manual(s):**

Please See Attached Exhibits

(c)(4): **Type of Emission:** GFSK

(c)(5): **FREQUENCY RANGE, MHz:** 2402 - 2477

(c)(6): **Power Rating:** 45.70 mV/m @ 3m
 Switchable Variable N/A

(c)(7): **Maximum Power Rating:** 50 mV/m @ 3m

15.203: Antenna Requirement:

- The antenna is permanently attached to the EUT
- The antenna uses a unique coupling
- The EUT must be professionally installed
- The antenna requirement does not apply

DUT Results: Passes Fails

Subpart 2.1033 (continued)

(c)(8): Voltages & Currents in All Elements in Final RF Stage, Including Final Transistor or Solid State Device:

Collector Current, A	=	0.07
Collector Voltage, Vdc	=	3.3
Supply Voltage, Vdc	=	5.0

(c)(9): **Tune-Up Procedure:**

Please See Attached Exhibits

(c)(10): **Circuit Diagram/Circuit Description:**

Including description of circuitry & devices provided for determining and stabilizing frequency, for suppression of spurious radiation, for limiting modulation and limiting power.

Please See Attached Exhibits

(c)(11): **Label Information:**

Please See Attached Exhibits

(c)(12): **Photographs:**

Please See Attached Exhibits

(c)(13): **Digital Modulation Description:**

Attached Exhibits
 N/A

(c)(14): **Test and Measurement Data:**

Follows

Name of Test: RF Power Output (Radiated)
Specification: 47 CFR 2.1046(a)
Test Equipment: As per attached page

Measurement Procedure (Radiated)

1. The EUT was placed on an open-field site and its radiated field strength at a known distance was measured by means of a spectrum analyzer. Equivalent loading was calculated from the equation $P_t = ((E \times R)^2 / 49.2)$ watts, where $R = 3m$.
2. Measurement accuracy is ± 1.5 dB.

Measurement Results

g0580056: 2005-Aug-24 Wed 12:53:00
 State: 2:High Power

Ambient Temperature: 35°C \pm 3°C

Frequency Tuned, MHz	Frequency Emission, MHz	dBuV/m	mV/m
2402.000000	2401.683333	93.2	45.70
2435.000000	2435.121944	93.0	44.67
2477.000000	2477.400000	93.1	44.99



Performed by:

Fred Chastain, Test Technician

Name of Test: Field Strength of Spurious Radiation

Specification: 47 CFR 2.1053(a)

Guide: ANSI/TIA/EIA-603-1992/2001, Paragraph 1.2.12 and Table 16, 47 CFR 22.917

Measurement Procedure

1.2.12.1 Definition: Radiated spurious emissions are emissions from the equipment when transmitting into a non-radiating load on a frequency or frequencies which are outside an occupied band sufficient to ensure transmission of information of required quality for the class of communications desired.

1.2.12.2 Method of Measurement

- A) Connect the equipment as illustrated
- B) Adjust the spectrum analyzer for the following settings:
 - 1) Resolution Bandwidth 100 kHz (<1 GHz), 1 MHz (> 1GHz).
 - 2) Video Bandwidth = 3 times Resolution Bandwidth, or 30 kHz (22.917)
 - 3) Sweep Speed ≤ 2000 Hz/second
 - 4) Detector Mode = Mean or Average Power
- C) Place the transmitter to be tested on the turntable in the standard test site. The transmitter is transmitting into a non-radiating load which is placed on the turntable. The RF cable to this load should be of minimum length.

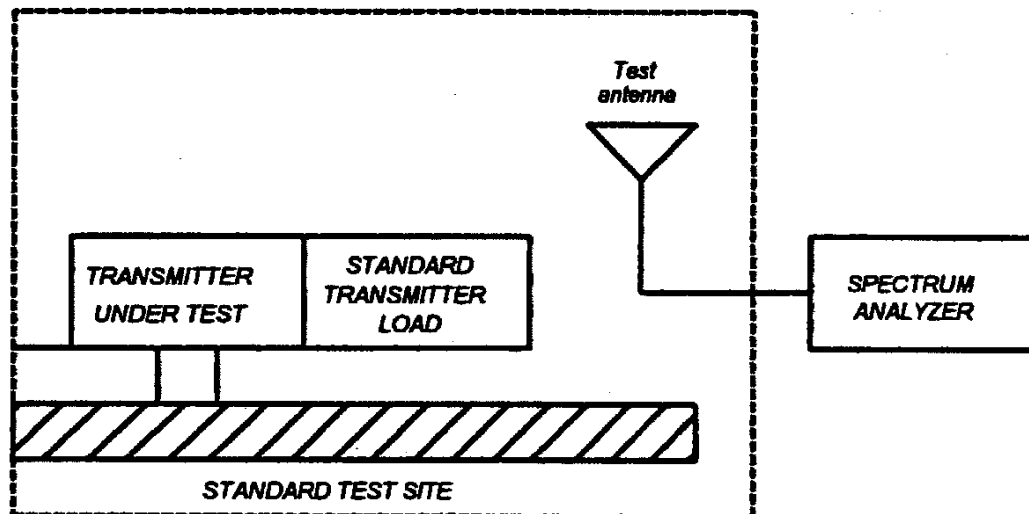

Name of Test: Field Strength of Spurious Radiation (Cont.)

- D) For each spurious measurement the test antenna should be adjusted to the correct length for the frequency involved. This length may be determined from a calibration ruler supplied with the equipment. Measurements shall be made from the lowest radio frequency generated in the equipment to the tenth harmonic of the carrier, except for the region close to the carrier equal to \pm the test bandwidth (see section 1.3.4.4).
- E) For each spurious frequency, raise and lower the test antenna from 1 m to 4 m to obtain a maximum reading on the spectrum analyzer with the test antenna at horizontal polarity. Repeat this procedure to obtain the highest possible reading. Record this maximum reading.
- F) Repeat step E) for each spurious frequency with the test antenna polarized vertically.

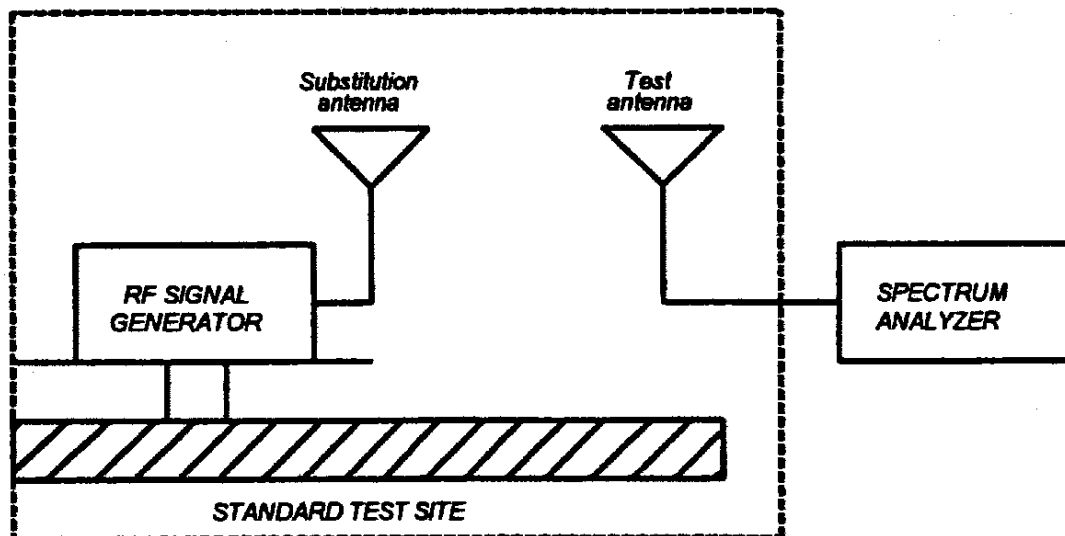

- G) Reconnect the equipment as illustrated.
- H) Keep the spectrum analyzer adjusted as in step B).
- I) Remove the transmitter and replace it with a substitution antenna (the antenna should be half-wavelength for each frequency involved). The center of the substitution antenna should be approximately at the same location as the center of the transmitter. At lower frequencies, where the substitution antenna is very long, this will be impossible to achieve when the antenna is polarized vertically. In such case the lower end of the antenna should be 0.3 m above the ground.

Name of Test: Field Strength of Spurious Radiation (Cont.)

- J) Feed the substitution antenna at the transmitter end with a signal generator connected to the antenna by means of a non-radiating cable. With the antennas at both ends horizontally polarized and with the signal generator tuned to a particular spurious frequency, raise and lower the test antenna to obtain a maximum reading at the spectrum analyzer. Adjust the level of the signal generator output until the previously recorded maximum reading for this set of conditions is obtained. This should be done carefully repeating the adjustment of the test antenna and generator output.
- K) Repeat step J) with both antennas vertically polarized for each spurious frequency.
- L) Calculate power in dBm into a reference ideal half-wave dipole antenna by reducing the readings obtained in steps J) and K) by the power loss in the cable between the generator and the antenna and further corrected for the gain of the substitution antenna used relative to an ideal half-wave dipole antenna.
- M) The levels recorded in step L) are absolute levels of radiated spurious emissions in dBm. The radiated spurious emissions in dB can be calculated by the following:

Radiated spurious emissions dB =
 $10 \log_{10}(\text{TX power in watts}/0.001) - \text{the levels in step l)}$

NOTE: It is permissible that other antennas provided can be referenced to a dipole.

Test Equipment:

Asset (as applicable)	Description	s/n	Cycle	Last Cal
Transducer				
X i00088	EMCO 3109-B 25MHz-300MHz	2336	24 mo.	Sep-03
	i00065 EMCO 3301-B Active Monopole	2635	24 mo.	Sep-03
X i00089	Apriel 2001 200MHz-1GHz	001500	24 mo.	Sep-03
X i00103	EMCO 3115 1GHz-18GHz	9208-3925	24 mo.	Jan-04
Amplifier				
X i00028	HP 8449A	2749A00121	12 mo.	May-05
Spectrum Analyzer				
X i00029	HP 8563E	3213A00104	12 mo.	May-05
X i00033	HP 85462A	3625A00357	12 mo.	Oct-04
	i00048 HP 8566B	2511AD1467	12 mo.	Jun-05

Test Setup:

Radiated Emissions

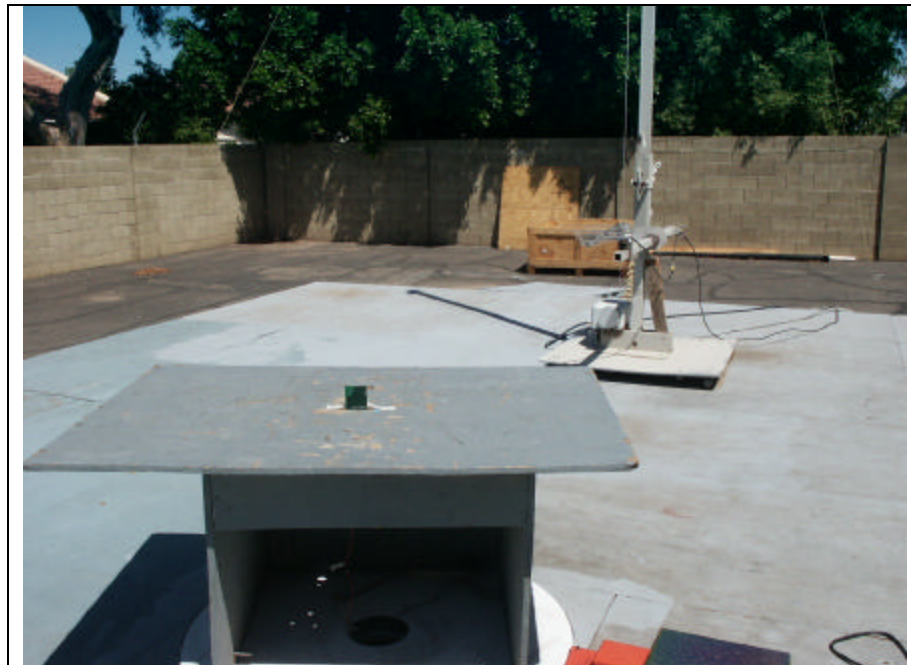

Name of Test: Field Strength of Spurious Radiation
g0580090: 2005-Aug-15 Mon 11:34:00
State: 2:High Power

Frequency Tuned, MHz	Frequency Emission, MHz	Meter, dBuV	CF, dB	uV/m @ 3m	ERP, dBm	Margin, dB
2402.000000	4800.095276	47.83	15.30	1433.84	-34.2	-21.3
2437.500000	4875.033609	49.33	15.27	1698.24	-32.8	-19.8
2477.000000	4955.148277	46.17	15.25	1177.61	-36.0	-23.0
2402.000000	7209.807943	45.67	17.29	1406.05	-34.4	-21.4
2437.500000	7312.702943	46.33	17.78	1605.09	-33.3	-20.3
2477.000000	7434.596943	45.33	18.37	1531.09	-33.7	-20.7
2402.000000	9610.926609	46.33	23.10	2961.42	-27.9	-15.0
2437.500000	9747.131943	46.33	22.91	2897.34	-28.1	-15.2
2477.000000	9904.570610	45.50	22.70	2570.40	-29.2	-16.2
2402.000000	12013.682610	45.83	26.92	4340.10	-24.6	-11.7
2437.500000	12185.851276	44.33	25.31	3033.89	-27.7	-14.8
2477.000000	12380.879277	45.00	23.52	2666.86	-28.9	-15.9
2402.000000	14415.472943	46.33	22.55	2779.71	-28.5	-15.5
2437.500000	14625.539609	44.83	23.50	2609.16	-29.0	-16.1
2477.000000	14858.935609	43.33	26.29	3026.91	-27.8	-14.8
2402.000000	16809.990610	45.50	19.99	1881.48	-31.9	-18.9
2437.500000	17059.158610	45.00	18.34	1468.93	-34.0	-21.1
2477.000000	17338.089610	44.83	21.25	2013.72	-31.3	-18.3
2477.000000	17340.799609	44.50	21.27	1943.12	-31.6	-18.6



Performed By:

Fred Chastain, Test Technician

Name of Test: Radiated Spurious Emissions (Non-Harmonic)

Specification: 47 CFR 15.249(c)

Guide: ANSI/TIA/EIA-603-1992, Paragraph 2.2.1

Test Equipment: As per previous page

15.249(c):

Emissions radiated outside of the specified frequency bands, except for harmonics, shall be attenuated by at least 50 dB below the level of the fundamental or to the general radiated emissions limits in § 15.209, whichever is the lesser attenuation.

General Radiated Emission Limits Per 15.209:

Frequency, MHz	Field Strength, $\mu\text{V}/\text{m}$ @ 3m
30 - 88	100
88 - 216	150
216 - 960	200
Above 960	300

Measurement Results: Attached

Measurement Results: Radiated Spurious Emissions (Non-Harmonic)

Frequency of Carrier, MHz =
 Spectrum Searched = 30MHz to 1GHz
 All Other Emissions = = 20 dB Below Limit
 Limit, $\mu\text{V} / \text{m} @ 3\text{m}$ = 50 dBc or § 15.209

g0580087: 2005-Aug-15 Mon 09:10:00
 State: 0: Horizontal

Frequency Emission, MHz	Level, dBuV @ m		C.F., dB	$\mu\text{V}/\text{m} @ \text{m}$		Margin, dB
39.653333	5.20	3	15.16	10.42	3	-19.6
40.128333	6.37	3	14.92	11.60	3	-18.7
41.290000	16.37	3	14.26	34.00	3	-9.4
46.116667	15.53	3	11.68	22.94	3	-12.8
51.461667	15.03	3	9.31	16.48	3	-15.7
52.230000	16.53	3	9.06	19.03	3	-14.4
56.635000	15.70	3	7.68	14.76	3	-16.6
59.791667	17.37	3	6.76	16.09	3	-15.9
63.131667	16.37	3	7.03	14.79	3	-16.6
65.761667	16.53	3	7.30	15.54	3	-16.2
86.391667	1.03	3	10.68	3.85	3	-28.3
131.758333	16.37	3	12.76	28.61	3	-13.9
181.262500	20.37	3	11.16	37.71	3	-11.5
181.262500	16.53	3	11.16	24.24	3	-15.3
207.845833	17.53	3	10.78	26.03	3	-14.7
225.029167	16.70	3	11.82	26.67	3	-17.5
235.929167	16.37	3	12.50	27.77	3	-17.1
257.470833	17.03	3	13.79	34.75	3	-15.2
304.362500	17.37	3	16.63	50.12	3	-12.0
401.795833	17.53	3	19.34	69.74	3	-9.1
538.787500	17.53	3	21.48	89.23	3	-7.0
673.113333	16.53	3	23.13	96.16	3	-6.3
724.015000	14.37	3	24.05	83.37	3	-7.6
774.193333	17.37	3	24.55	124.74	3	-4.1



Performed By:

Fred Chastain, Test Technician

Measurement Results: Radiated Spurious Emissions (Non-Harmonic) (Continued)

g0580088: 2005-Aug-15 Mon 10:21:00
State: 0: Vertical

Frequency Emission, MHz	Level, dBuV @ m		C.F., dB	μ V/m @ m		Margin, dB
39.653000	17.23	3	12.26	29.82	3	-10.5
40.126000	19.43	3	12.32	38.68	3	-8.3
41.288000	16.86	3	12.33	28.81	3	-10.8
46.112000	16.20	3	12.29	26.58	3	-11.5
51.457000	15.93	3	11.56	23.69	3	-12.5
52.225000	16.33	3	11.43	24.43	3	-12.2
56.630000	17.13	3	10.66	24.52	3	-12.2
59.785000	17.16	3	10.15	23.20	3	-12.7
86.385000	17.48	3	7.82	18.41	3	-14.7
131.753000	11.82	3	11.75	15.08	3	-19.4
207.844500	4.28	3	14.33	8.52	3	-24.4
225.028500	2.47	3	15.35	7.78	3	-28.2
235.928500	3.19	3	15.91	9.02	3	-26.9
257.469500	4.05	3	18.17	12.91	3	-23.8
304.361500	4.63	3	15.38	10.01	3	-26.0
401.999500	6.39	3	17.52	15.69	3	-22.1
538.780000	1.79	3	21.21	14.13	3	-23.0
673.108100	5.59	3	25.95	37.76	3	-14.5
775.185100	5.92	3	25.43	36.94	3	-14.7
840.690000	5.29	3	25.53	34.75	3	-15.2
899.940000	6.53	3	26.12	42.90	3	-13.4

All Spurious Emissions Were 20 Db or More Below Limit

System Sensitivity IS -130 dBm

All Non-Harmonic Spurious Emissions Were, -130 dBm



Performed By:

Fred Chastain, Test Technician

Name of Test: Emission Masks (Occupied Bandwidth)
Specification: 47 CFR 2.1049(c)(1)
Guide: ANSI/TIA/EIA-603-1992, Paragraph 2.2.11
Test Equipment: As per previous page

Measurement Procedure

1. The EUT and test equipment were set up as shown on the following page, with the Spectrum Analyzer connected.
2. For EUTs supporting audio modulation, the audio signal generator was adjusted to the frequency of maximum response and with output level set for ± 2.5 kHz deviation (or 50% modulation). With level constant, the signal level was increased 16 dB.
3. For EUTs supporting digital modulation, the digital modulation mode was operated to its maximum extent.
4. The Occupied Bandwidth was measured with the Spectrum Analyzer controls set as shown on the test results.
5. Measurement Results: Attached

Transmitter Spurious Emission

Test A. Occupied Bandwidth (In-Band Spurious)
Test B. Out-of-Band Spurious

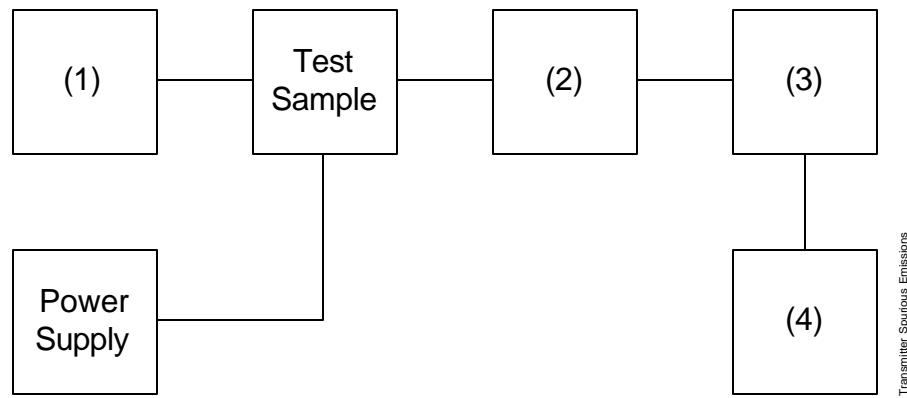

Asset	Description (as applicable)	s/n		
(1) Audio Oscillator/Generator				
X	i00017 HP 8903A Modulation Meter	2216A01753	12 mo.	Apr-05
(2) Coaxial Attenuator				
X	i00231/2 PASTERNAK PE7021-30 (30 dB)	231 or 232	NCR	
	i00123 NARDA 766 (10 dB)	7802A	NCR	
(3) Interface				
X	i00021 HP 8954A Transceiver Interface	2146A00159	NCR	
(4) Spectrum Analyzer				
X	i00048 HP 8566B Spectrum Analyzer	2511A01467	12 mo.	Oct-04
	i00029 HP 8563E Spectrum Analyzer	3213A00104	12 mo.	May-05

Name of Test: Emission Masks (Occupied Bandwidth)
 g0580091: 2005-Aug-15 Mon 13:20:00
 State: 0:General

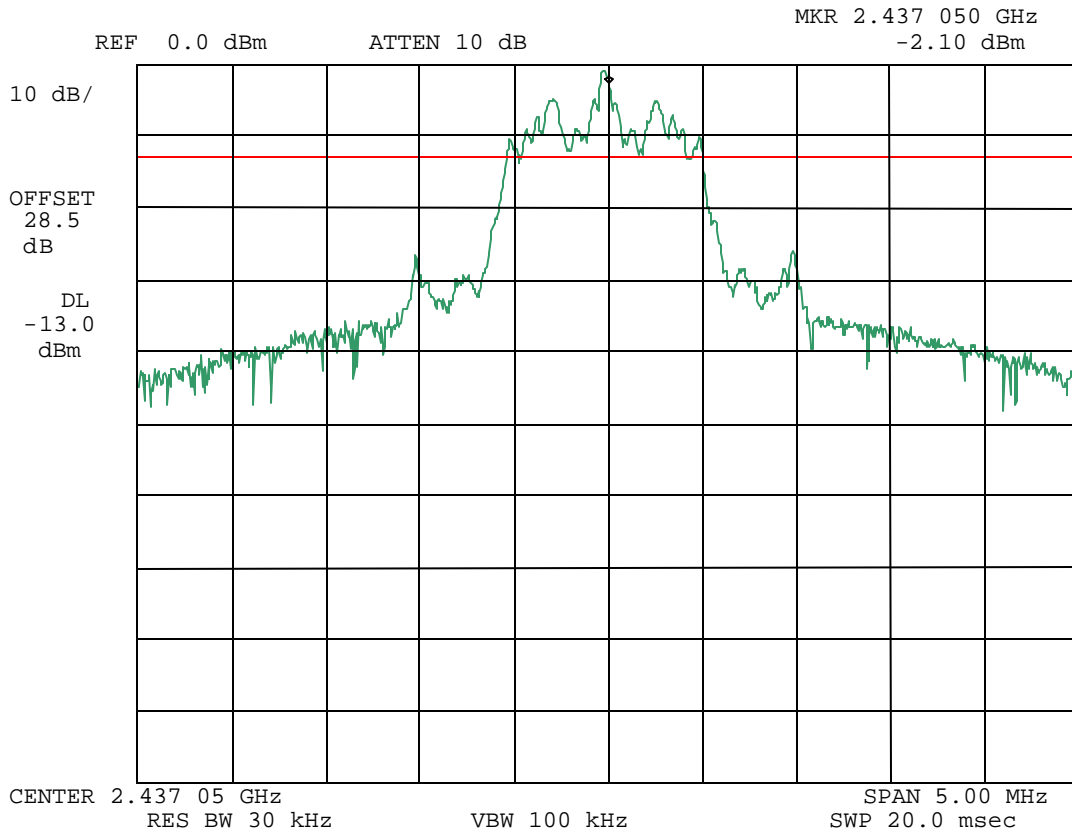

Power:
 Modulation:

HIGH (Loose Coupled)
 CENTER CHANNEL

Performed By:

Fred Chastain, Test Technician

Name of Test: Emission Masks (Occupied Bandwidth)
 g0580092: 2005-Aug-15 Mon 13:21:00
 State: 0:General

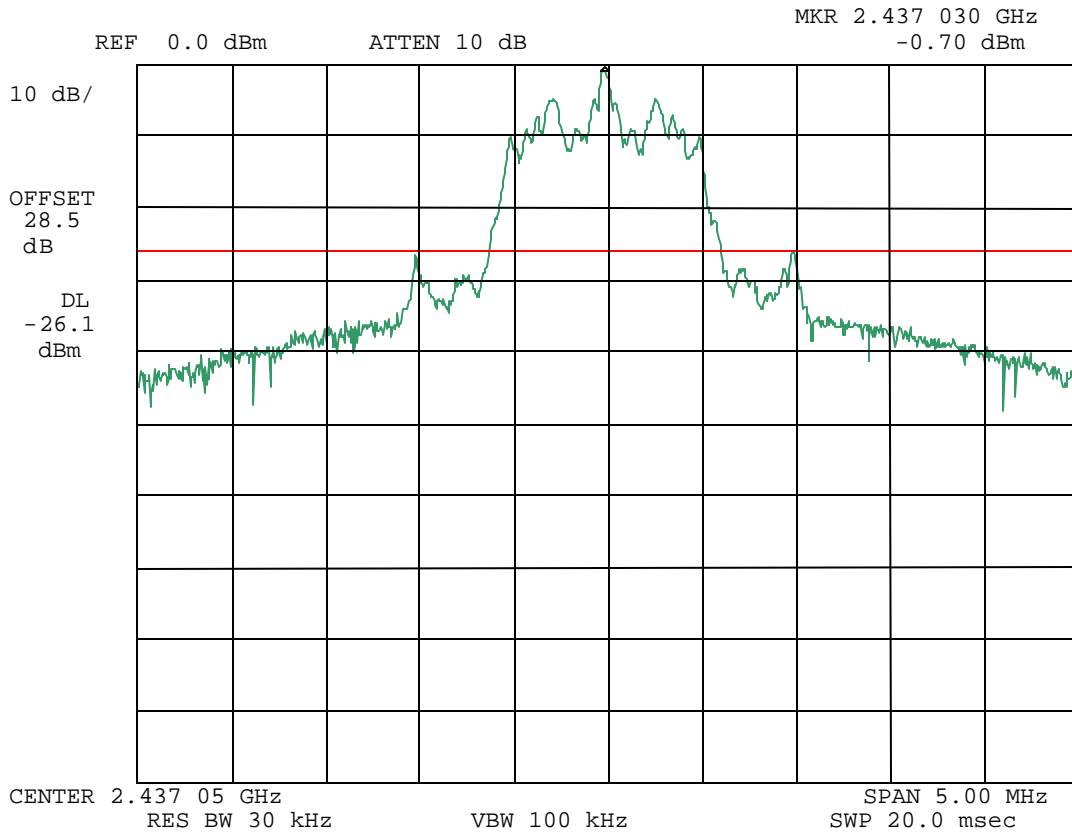

Power:
 Modulation:

HIGH (Loose Coupled)
 CENTER CHANNEL



Performed By:

Fred Chastain, Test Technician

Name of Test: Emission Masks (Occupied Bandwidth)
 g0580095: 2005-Aug-15 Mon 13:33:00
 State: 2:High Power

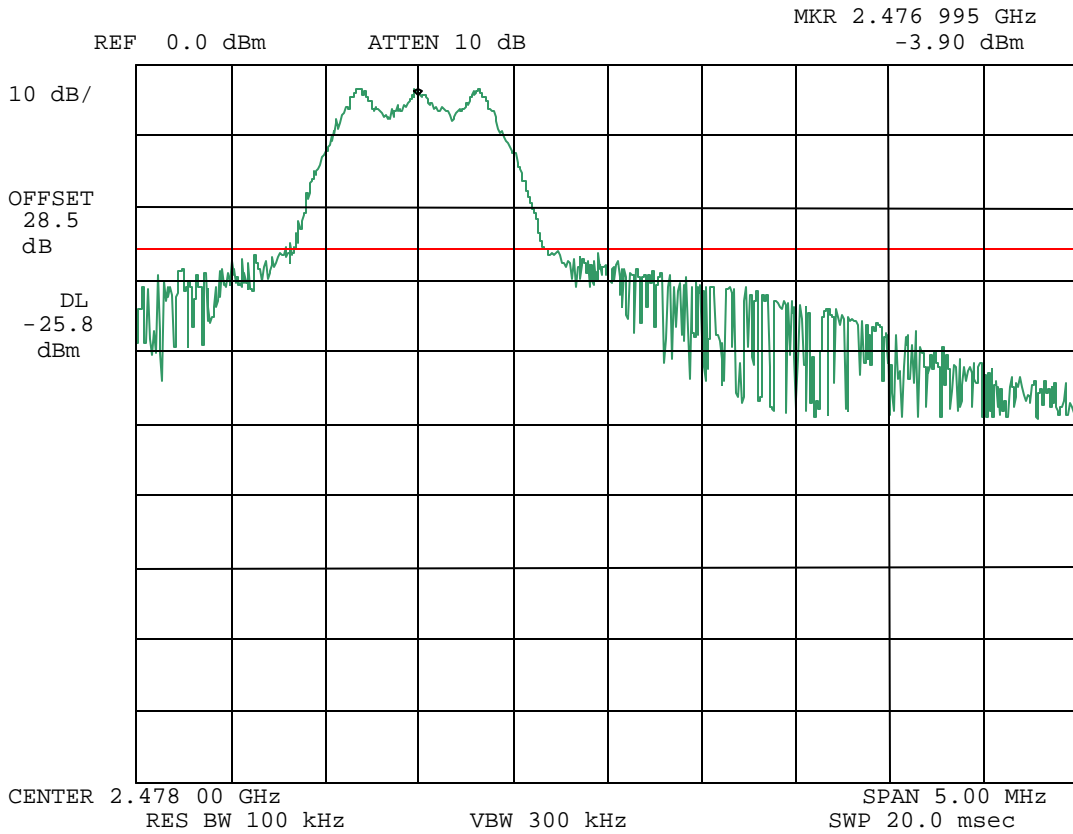

Power:
 Modulation:

HIGH (Loose Coupled)
 HIGH CHANNEL



Performed By:

Fred Chastain, Test Technician

Name of Test: Emission Masks (Occupied Bandwidth)
g0580096: 2005-Aug-15 Mon 13:35:00
State: 2:High Power

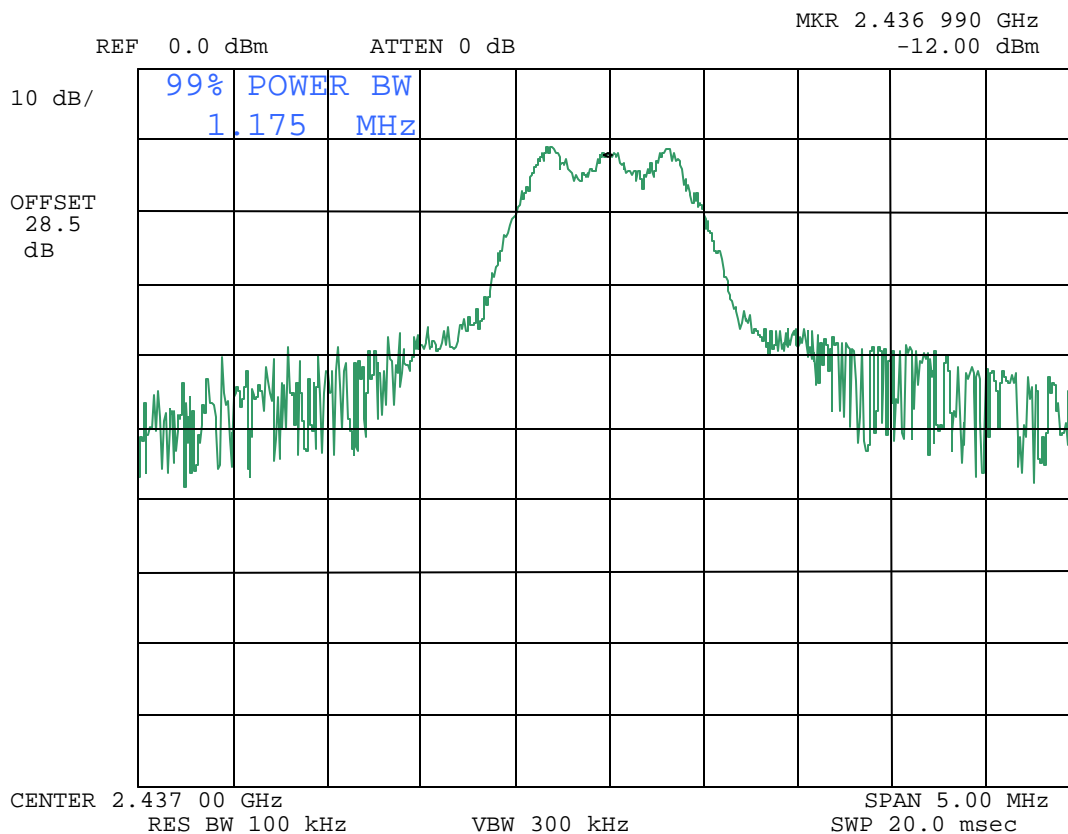

Power:
Modulation:

HIGH (Loose Coupled)
99% BANDWIDTH

Performed By:

Fred Chastain, Test Technician

Name of Test: Emission Masks (Occupied Bandwidth)
 g0580094: 2005-Aug-15 Mon 13:28:00
 State: 2:High Power

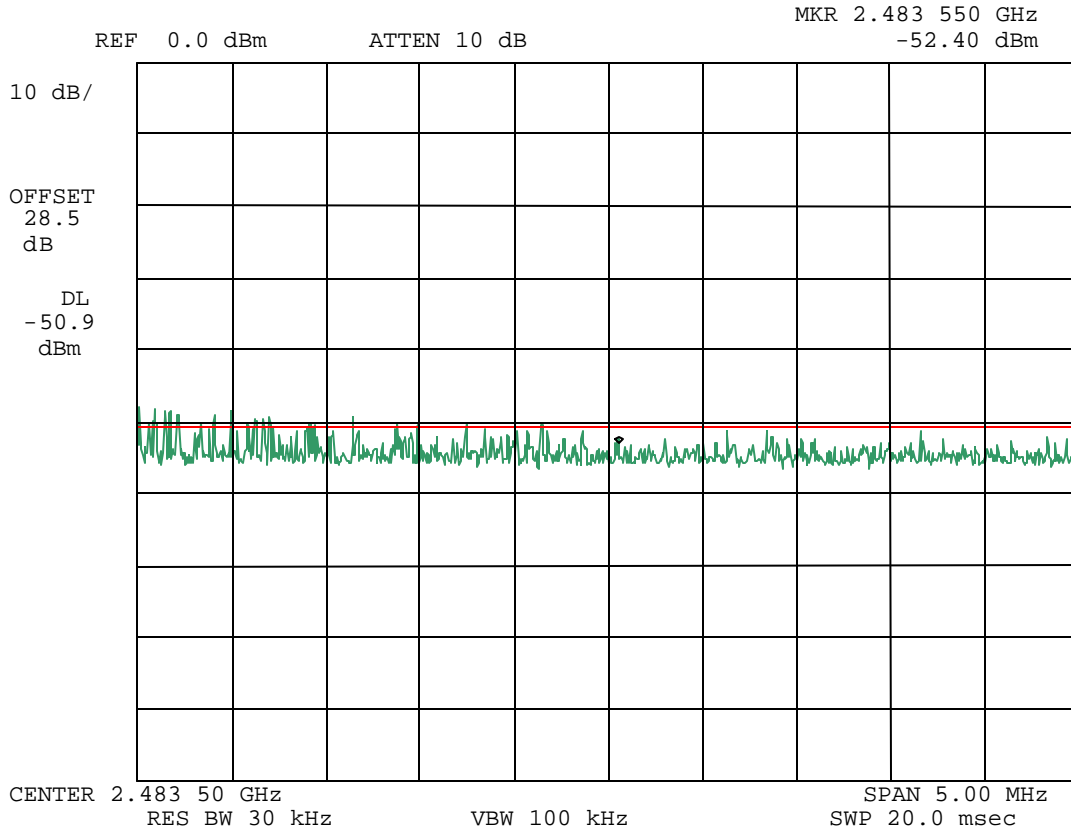

Power:
Modulation:

HIGH (Loose Coupled)
HIGH BAND EDGE



Performed By:

Fred Chastain, Test Technician

Name of Test: A/C Powerline Conducted Emissions
Specification: FCC: 47 CFR 15.27
Guide: IEEE Standard 213
Test Conditions: S. T. & H.
Test Equipment: As per attached page

Measurement Procedure

1. A test sample was connected to the Public Utility lines through a LISN Ailtech Model 94641-1 (50 μ H).
2. A reference level of 250 μ V was set on the Spectrum Analyzer. The spectrum was searched over the range of 450 kHz to 30 MHz.
3. All other emissions were 20 dB or more below limit.
4. The test sample used a charger.
 The test sample does not use a charger.
5. Measurement Results: Attached.

AC Powerline Conducted Measurements

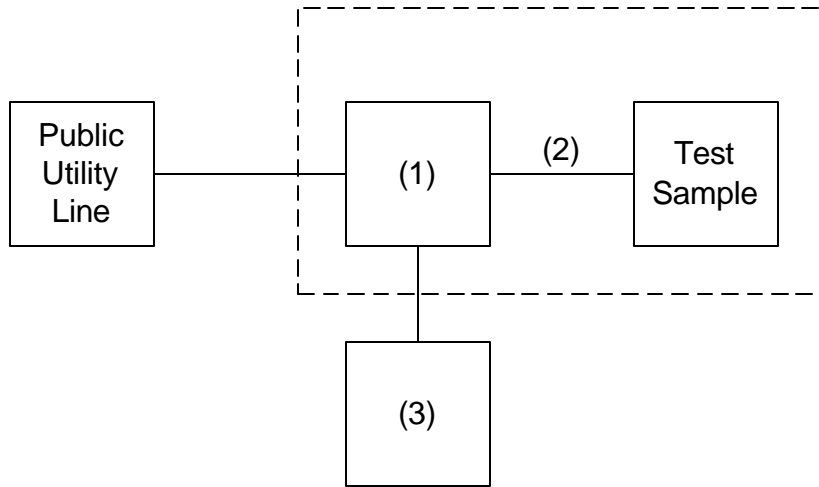

Asset	Description	s/n	Cycle	Last Cal
(1) Line Impedance Stabilization Network				
X	i00244 Fischer 50-20-2-01	2047		
(2) Screen Room				
X	i00170 Lindgren LG170	4999		
(3) Spectrum Analyzer				
X	i00033 HP 85462A	3625A00357	12 mo.	Oct-04
	i00048 HP 8566B	2511AD1467	12 mo.	Jun-05

Test Setup:

A/C Powerline Conducted Emissions

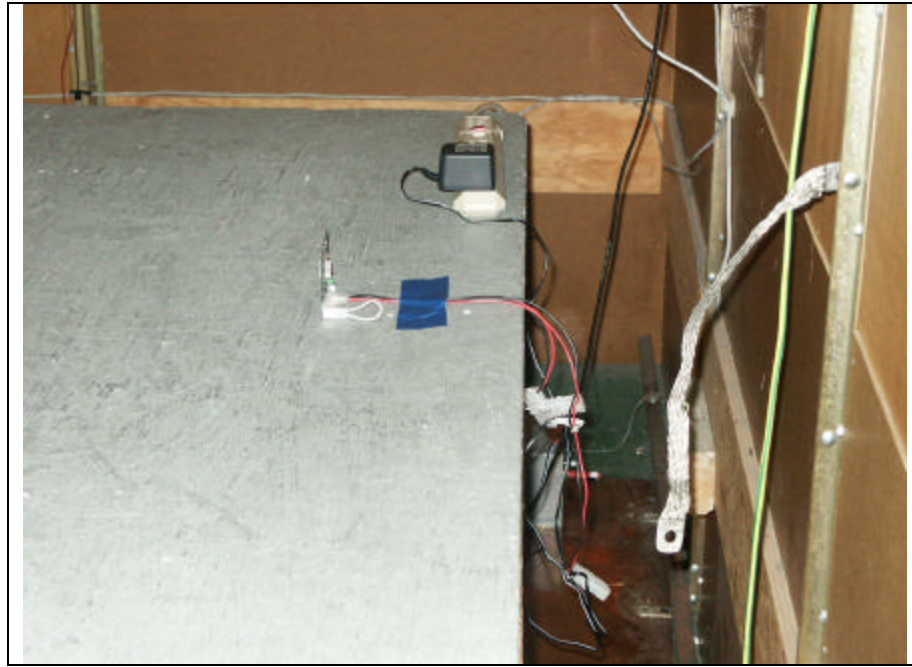

Name of Test: A/C Powerline Conducted Emissions

g0580097: 2005-Aug-15 Mon 13:43:00

State: 0:General

Frequency Tuned, MHz	Frequency Emission, MHz	Level, dBuV	C.F., dB	$\mu\text{V}/\text{m}$
2437.500000	0.150000	42.85	1.35	162.18
2437.500000	0.200000	21.34	0.94	13.00
2437.500000	0.680000	23.18	0.60	15.45
2437.500000	3.930000	9.96	0.64	3.39
2437.500000	14.370000	12.57	1.15	4.85
2437.500000	17.890000	17.52	1.49	8.92
2437.500000	23.350000	18.53	1.64	10.20

g0580098: 2005-Aug-15 Mon 13:49:00

State: 0:General

Frequency Tuned, MHz	Frequency Emission, MHz	Level, dBuV	C.F., dB	$\mu\text{V}/\text{m}$
2437.500000	0.150000	29.22	1.39	33.92
2437.500000	0.500000	32.09	0.59	43.05
2437.500000	5.190000	10.24	0.73	3.54
2437.500000	14.500000	11.64	1.19	4.38
2437.500000	18.010000	16.04	1.60	7.62
2437.500000	23.520000	19.40	1.69	11.34
2437.500000	26.130000	17.74	1.82	9.51



Performed By:

Fred Chastain, Test Technician

Name of Test: Necessary Bandwidth and Emission Bandwidth

Specification: 47 CFR 2.202(g)

Modulation = GFSK

Necessary Bandwidth Calculation:

Measured

= 1.175MHz
(Limit min 500kHz)



Performed By:

Fred Chastain, Test Technician

**Radiated Measurements
For Part 15 Transmitters with Integral Antennas**

Radiated Measurements

Range Of Measurement	Specification	Resolution B/W	Video B/A
30 to 1000 MHz	CISPR	=100 kHz	=100 kHz
>1000 MHz (if averaging)	FCC, 15.37(b) FCC, 15.37(b)	1 MHz 1 MHz	=1 MHz 10 Hz

Measuring Equipment

a. Antennas:

EMCO 3109	20 - 300 MHz
APREL AALP2001	200 - 1000 MHz
APREL AAB20200	20 - 200 MHz
APREL AAH118	1 - 18 GHz

b. Instruments:

HP8566B	Spectrum Analyzer
HP85685A	Preselector, w/ preamp below 2 GHz
HP85650A	Quasi Peak Adapter
HP8449	Preamp, above 2 GHz

All test instrumentation is calibrated every January and every July. In addition, all test instrumentation is calibrated daily, or as required by the manufacturer. A Calibration Agreement is maintained with Hewlett Packard.

Occupied Bandwidth

Occupied Bandwidth is measured as a radiated signal without attenuators and/or filter. RBW, VBW and scan settings as shown were set to produce a meaningful result in accordance with ANSI C63.4, Section 13.1.7.

Part 15.21, Information to User

The users manual or instruction manual for an intentional or unintentional radiator shall caution the user that changes or modifications not expressly avoided by the party responsible for compliance could void the user's authority to operate the equipment.

§ 15.205 Restricted Bands of Operation

(a) Except as shown in paragraph (b) of this section, only spurious emissions are permitted in any of the frequency bands listed below:

MHz	MHz	MHz	GHz
0.090-0.110	16.42-16.423	399.9-410	4.5-5.25
0.495-0.505	16.69475-16.69625	608-614	5.35-5.46
2.1735-2.1905	16.80425-16.80475	960-1240	7.25-7.75
4.125-4.128	25.5-25.67	1300-1427	8.025-8.5
4.17725-4.17775	37.5-38.25	1435-1626.5	9.0-9.2
4.20725-4.20775	73-74.6	1645.5-1646.5	9.3-9.5
6.215-6.218	74.8-75.2	1660-1710	10.6-12.7
6.26775-6.26825	108-121.94	1718.8-1722.2	13.25-13.4
6.31175-6.31225	123-138	2200-2300	14.47-14.5
8.291-8.294	149.9-150.05	2310-2390	15.35-16.2
8.362-8.366	156.52475-156.52525	2483.5-2500	17.7-21.4
8.37625-8.38675	156.7-156.9	2655-2900	22.01-23.12
8.41425-8.41475	162.0125-167.17	3260-3267	23.6-24.0
12.29-12.293	167.72-173.2	3332-3339	31.2-31.8
12.51975-12.52025	240-285	3345.8-3358	36.43-36.5
12.57675-12.57725	322-339.4	3600-4400	
13.36-13.41			

**Testimonial
and
Statement of Certification**

This is to certify that:

1. **That** the application was prepared either by, or under the direct supervision of, the undersigned.
2. **That** the technical data supplied with the application was taken under my direction and supervision.
3. **That** the data was obtained on representative units, randomly selected.
4. **That**, to the best of my knowledge and belief, the facts set forth in the application and accompanying technical data are true and correct.

Certifying Engineer:



David E. Lee, Quality Assurance Manager