

ITEM NO.	PART NUMBER	REV	DESCRIPTION	QTY.
1	100-070-107	D	DR4100 READER ASSEMBLY	1
2	PRODIDLABEL	B	PRODUCT ID LABEL	1
3	DOC1329	A	DR4XXX COMPLIANCE LABEL	1
4	100-070-109	C	DR41XX/DR42XX HARDWARE KIT	1
5	DOC1330	A	DR4000 SERIES READER INSTALLATION GUIDE	1
6	DOC1334	-	FeliCa LABEL	1

△ △

FOR REFERENCE ONLY

REVISIO			
REV.	DESCRIPTION	DATE	APPROVED
A	PROTOTYPE RELEASE	04/15/2010	CNC
B	CO 5939, CO 5940, C05943	11/9/2010	CNC
C	CO59XX, C05946	11/17/2010	CNC

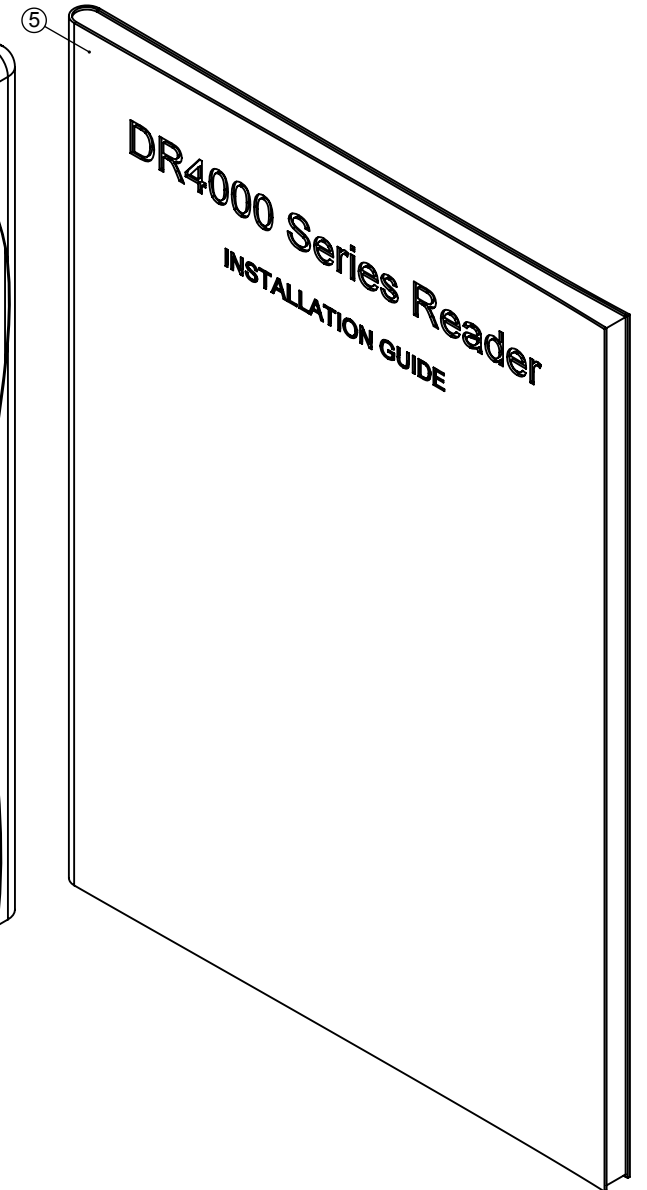
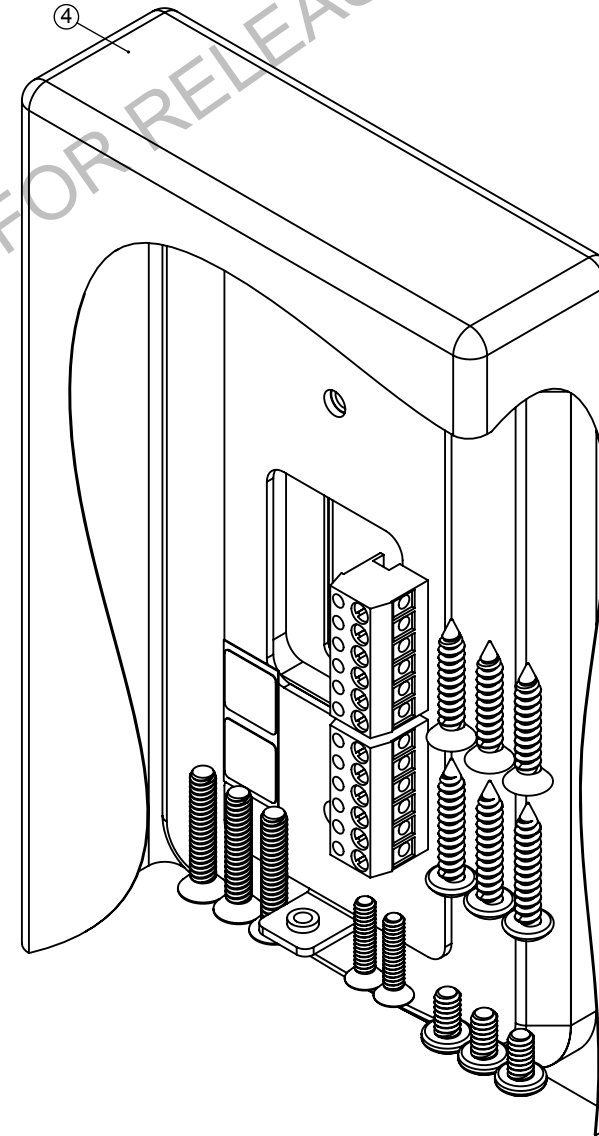
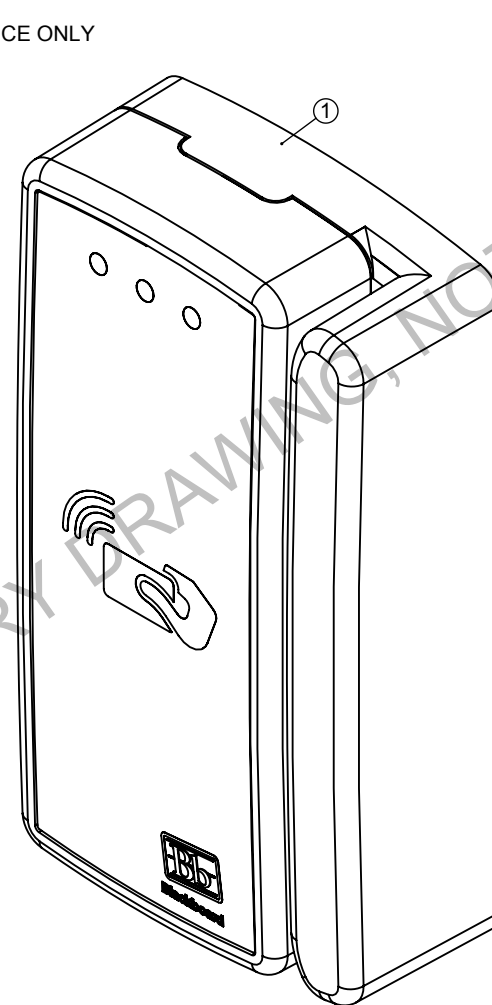
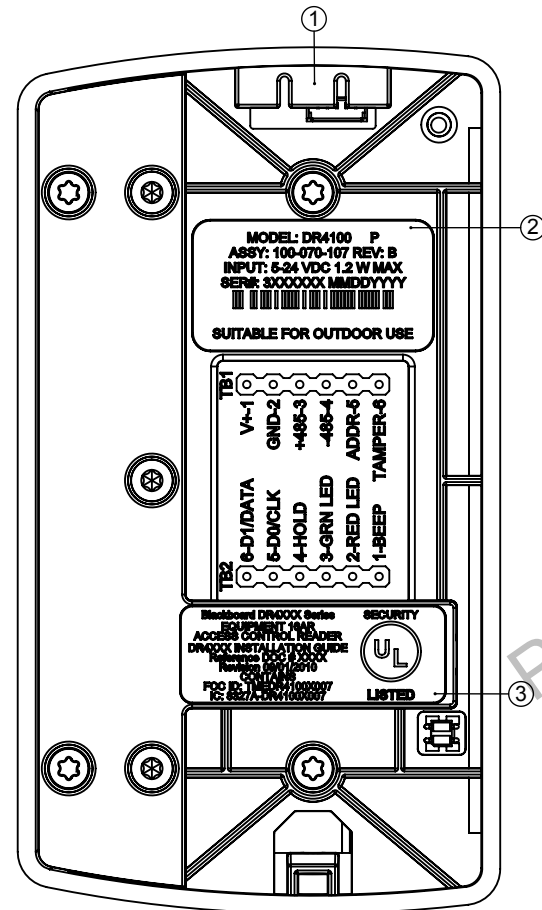

△

NOTES:

- REFER TO THE BLACKBOARD PRODUCT PROGRAMMING AND TEST MANUAL (DOC1306) FOR FINAL UNIT SETUP AND TESTING.
- CREATE PRODUCT IDENTIFICATION LABEL (ITEM 2) WITH SERIAL NUMBER (SEE SHEET 3) AND APPLY IN POSITION SHOWN.
- APPLY DR4100 COMPLIANCE LABEL (ITEM 3) AS SHOWN.

△

DR4100 PACKAGING INSTRUCTIONS

- PACKAGING IS TO BE DETERMINED BY THE CONTRACT MANUFACTURE. PACKAGING DESIGN MUST PROTECT PRODUCT FROM ANY SHIPPING DAMAGE. DETAILED DRAWINGS AND SAMPLES OF THE PACKAGING TO BE SUPPLIED TO BLACKBOARD ENGINEERING FOR APPROVAL PRIOR TO PRODUCTION.
- PACKAGING TO HOLD THE ITEMS SHOWN ABOVE. ITEMS INCLUDE THE DR4100 (ITEM 1), DR41XX/DR42XX HARDWARE KIT (ITEM 4), AND DR4100 INSTALLATION GUIDE (ITEM 5).
- A STOCK TAG THAT IDENTIFIES THE PRODUCT AND PRODUCTS SERIAL NUMBER AND A FeliCa LABEL (DOC1334) IS TO BE APPLIED TO THE PACKAGING.

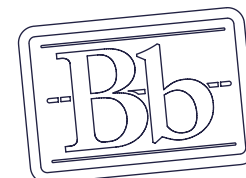

PROPRIETARY AND CONFIDENTIAL
THE INFORMATION CONTAINED IN THIS DRAWING IS THE SOLE PROPERTY OF BLACKBOARD INC. ANY REPRODUCTION IN PART OR AS A WHOLE WITHOUT THE WRITTEN PERMISSION OF BLACKBOARD INC. IS PROHIBITED.

UNLESS OTHERWISE SPECIFIED:		NAME	DATE
DIMENSIONS ARE IN INCHES DEBURR AND BREAK ALL SHARPS		DRAWN	CNC 04/15/2010
TOLERANCES: DECIMALS: X = ± .1 XX = ± .01 XXX = ± .005		CHECKED	
FRACTIONS: ± 1/64		ENG APPR.	
ANGULAR: ± .5°		MFG APPR.	
INTERPRET GEOMETRIC TOLERANCING PER: ANSI Y14.5		Q.A.	
MATERIAL: N/A		COMMENTS:	
FINISH: N/A			
DO NOT SCALE DRAWING			

Blackboard Inc. Phoenix, Arizona			
TITLE: DR4100 FeliCa+Mag STRIPE DOOR READER			
SIZE B	DWG. NO. DR4100	REV C	
SCALE: 1:1		SHEET 1 OF 3	

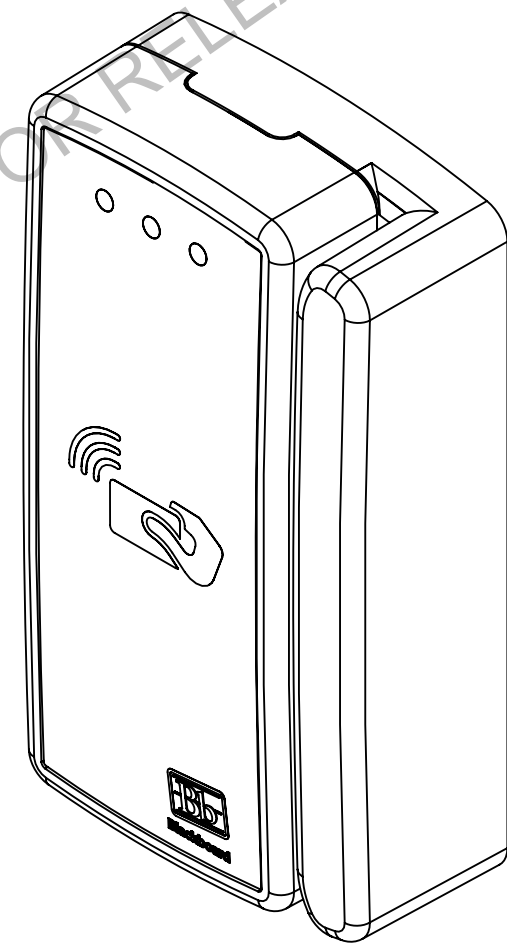
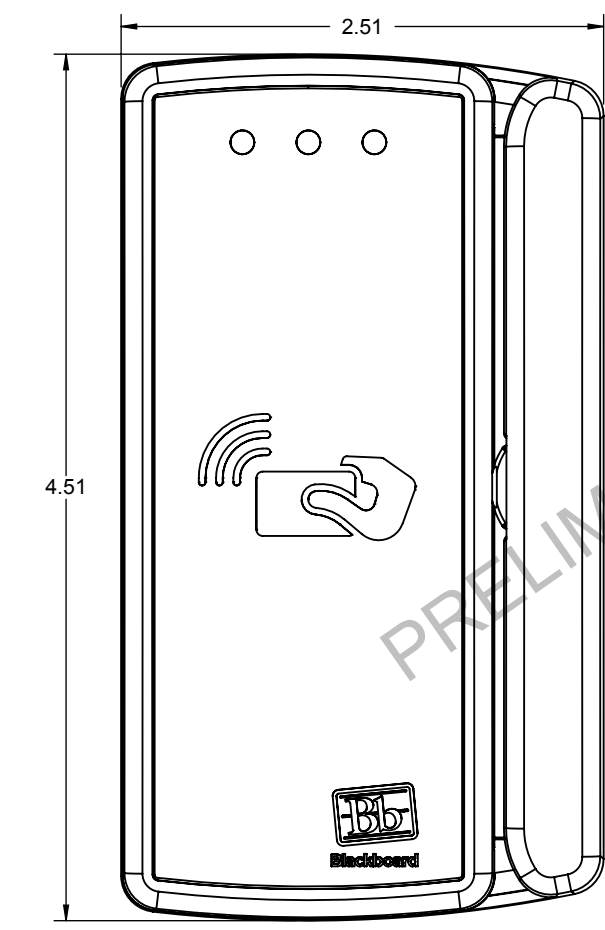
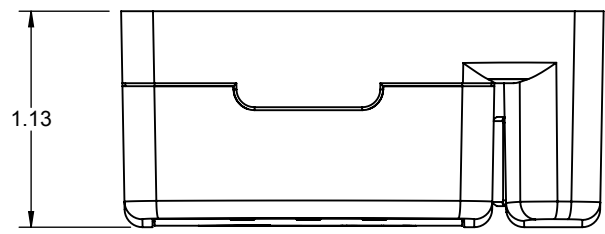

PRELIMINARY DRAWING, NOT FOR RELEASE

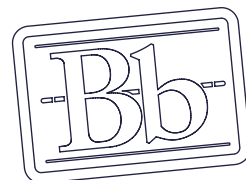

PROPRIETARY AND CONFIDENTIAL
 THE INFORMATION CONTAINED IN THIS DRAWING IS THE SOLE PROPERTY OF BLACKBOARD INC. ANY REPRODUCTION IN PART OR AS A WHOLE WITHOUT THE WRITTEN PERMISSION OF BLACKBOARD INC. IS PROHIBITED.

UNLESS OTHERWISE SPECIFIED:		NAME	DATE
DIMENSIONS ARE IN INCHES DEBURR AND BREAK ALL SHARPS		DRAWN	CNC 04/15/2010
TOLERANCES:		CHECKED	
DECIMALS: X = ± .1 .XX = ± .01 .XXX = ± .005		ENG APPR.	
FRACTIONS: ± 1/64		MFG APPR.	
ANGULAR: ± .5°		Q.A.	
INTERPRET GEOMETRIC TOLERANCING PER: ANSI Y14.5		COMMENTS:	
MATERIAL: N/A			
FINISH: N/A			
DO NOT SCALE DRAWING			

Blackboard Inc. Phoenix, Arizona			
TITLE: DR4100 FeliCa+Mag STRIPE DOOR READER			
SIZE	DWG. NO.	REV	
B	DR4100	C	
SCALE: 1:1		SHEET 2 OF 3	

MODEL: DR4100
 ASSEM: 100-070-107
 INPUT: 5-24 VDC 1.2 W MAX
 SERIAL NUMBER: 3XXXXXX
 BAR CODE: SEE NOTES.

MODEL: DR4100 P
 ASSY: 100-070-107 REV: B
 INPUT: 5-24 VDC 1.2 W MAX
 SER#: 3XXXXXX MMDDYYYY

MANUFACTURE CODE: P
 REVISION: B
 DATE CODE: MMDDYYYY
 ADDITIONAL INFORMATION:
 SUITABLE FOR OUTDOOR USE.

SUITABLE FOR OUTDOOR USE

- LABEL MATERIAL:** DOC1058
- LABEL INFORMATION:**
 MODEL: DR4100
 MANUFACTURE CODE: P
 DITRON = D, PRIDE INDUSTRIES = P
 ASSEMBLY NUMBER: 100-070-107

REVISION: B
 CURRENT REVISION OF THE ASSEMBLY IN LETTER FORMAT.

INPUT: 5-24 VDC 1.2 W MAX

SERIAL NUMBER: 3XXXXXX
 THE 7 DIGIT SERIAL NUMBER IS CREATED FROM THE BELOW RANGE IN SEQUENTIAL ORDER.
 STARTING SERIAL NUMBER: 3000000
 ENDING SERIAL NUMBER: 4999999

DATE CODE: MMDDYYYY
 THE DATE CODE IS THE DATE OF MANUFACTURE IN MMDDYYYY FORMAT, WHERE MM IS THE 2 DIGIT MONTH, DD IS THE 2 DIGIT DAY AND YYYY IS THE 4 DIGIT YEAR.

BARCODE: SYMBOLOGY TYPE, CODE 3 OF 9.
 INFORMATION CONTAINED IN THE BARCODE IS THE SERIAL NUMBER.

ADDITIONAL INFORMATION: SUITABLE FOR OUTDOOR USE

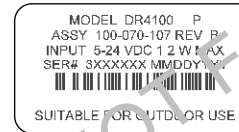

FINISHED LABEL EXAMPLE
 SCALE: 1:1

PRELIMINARY DRAWING, NOT FOR RELEASE



PROPRIETARY AND CONFIDENTIAL
 THE INFORMATION CONTAINED IN THIS DRAWING IS THE SOLE PROPERTY OF BLACKBOARD INC. ANY REPRODUCTION IN PART OR AS A WHOLE WITHOUT THE WRITTEN PERMISSION OF BLACKBOARD INC. IS PROHIBITED.

UNLESS OTHERWISE SPECIFIED:		NAME	DATE	Blackboard Inc. Phoenix, Arizona	
DIMENSIONS ARE IN INCHES DEBURR AND BREAK ALL SHARPS TOLERANCES: DECIMALS: FRACTIONS: ANGULAR:	DRAWN	CNC	04/15/2010	TITLE: DR4100 FeliCa+Mag STRIPE DOOR READER	
	CHECKED			SIZE	DWG. NO.
	ENG APPR.			A	DR4100
INTERPRET GEOMETRIC TOLERANCING PER:	ANSI Y14.5	MFG APPR.			REV C
MATERIAL	N/A	Q.A.			
FINISH	N/A	COMMENTS:			
DO NOT SCALE DRAWING				SCALE: 3:1	SHEET 3 OF 3