

30MHz~3GHz_Band12_3MHz_QPSK_1_0_LowCH23025-700.5

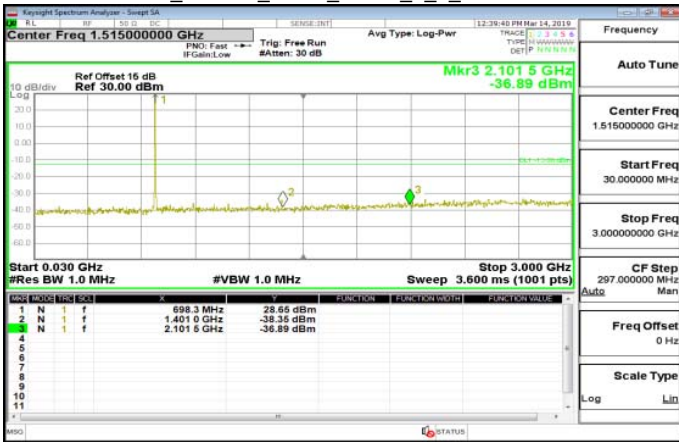

3GHz~10GHz_Band12_3MHz_QPSK_1_0_MidCH23095-707.5

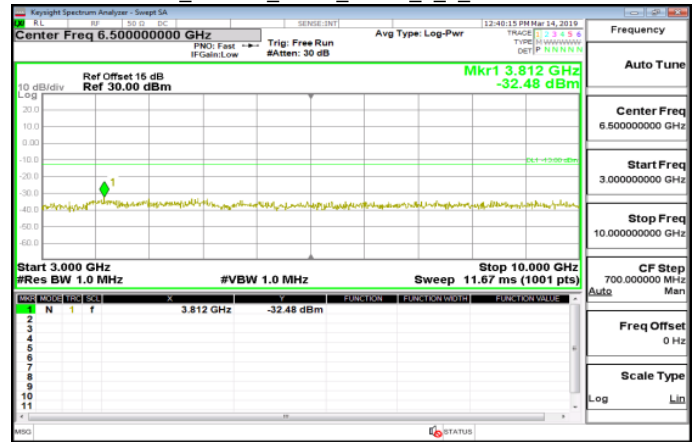

3GHz~10GHz_Band12_3MHz_QPSK_1_0_LowCH23025-700.5

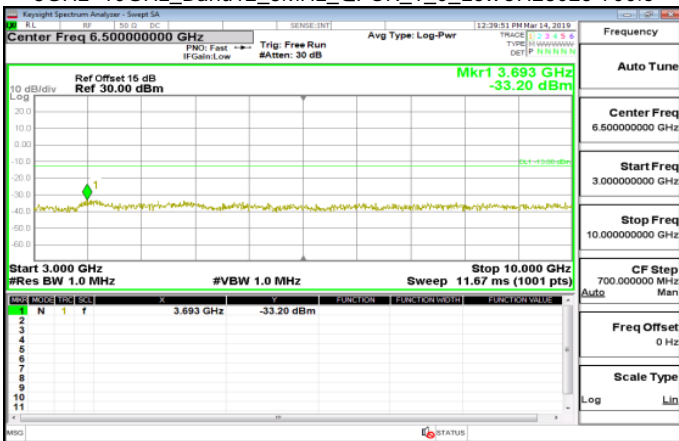

30MHz~3GHz_Band12_3MHz_QPSK_1_0_HighCH23165-714.5

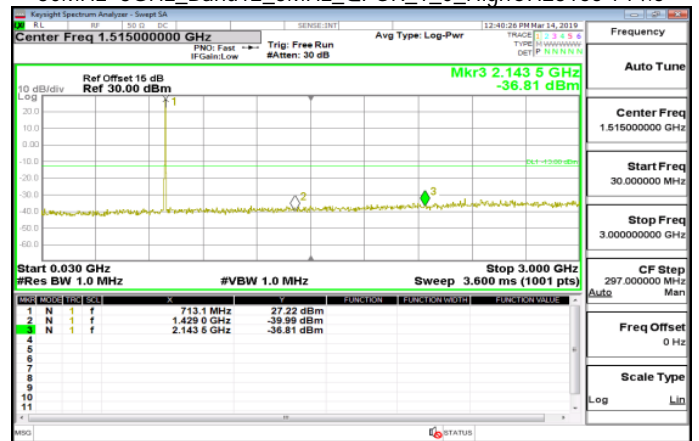

30MHz~3GHz_Band12_3MHz_QPSK_1_0_MidCH23095-707.5

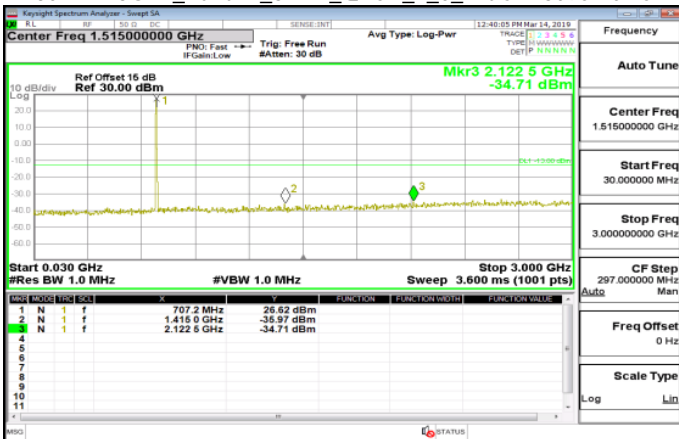

3GHz~10GHz_Band12_3MHz_QPSK_1_0_HighCH23165-714.5

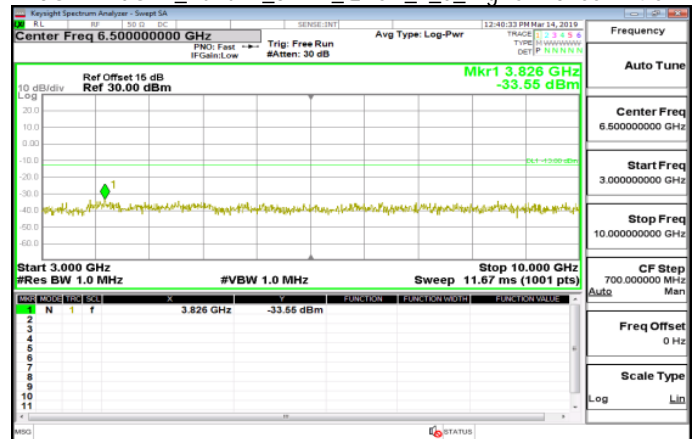

Unless otherwise stated the results shown in this test report refer only to the sample(s) tested and such sample(s) are retained for 90 days only.

除非另有說明，此報告結果僅對測試之樣品負責，同時此樣品僅保留90天。本報告未經本公司書面許可，不可部份複製。

This document is issued by the Company subject to its General Conditions of Service printed overleaf, available on request or accessible at www.sgs.com/terms_and_conditions.htm and for electronic format documents, subject to Terms and Conditions for Electronic Documents at www.sgs.com/terms_e-document.htm. Attention is drawn to the limitation of liability, indemnification and jurisdiction issues defined therein. Any holder of this document is advised that information contained hereon reflects the Company's findings at the time of its intervention only and within the limits of Client's instructions, if any. The Company's sole responsibility is to its Client and this document does not exonerate parties to a transaction from exercising all their rights and obligations under the transaction documents. This document cannot be reproduced except in full, without prior written approval of the Company. Any unauthorized alteration, forgery or falsification of the content or appearance of this document is unlawful and offenders may be prosecuted to the fullest extent of the law.

30MHz~3GHz_Band12_5MHz_QPSK_1_0_LowCH23035-701.5

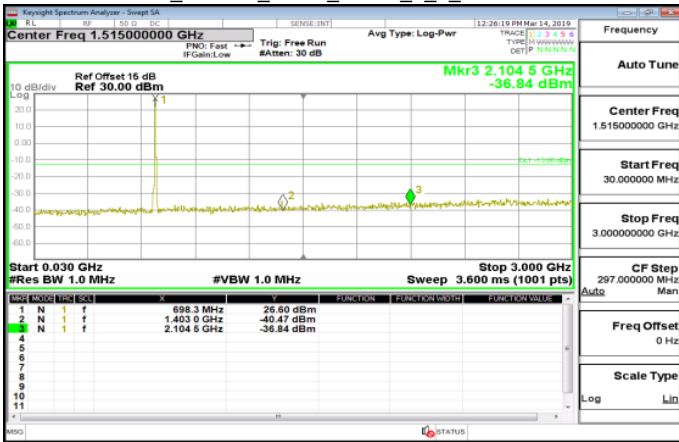

3GHz~10GHz_Band12_5MHz_QPSK_1_0_MidCH23095-707.5

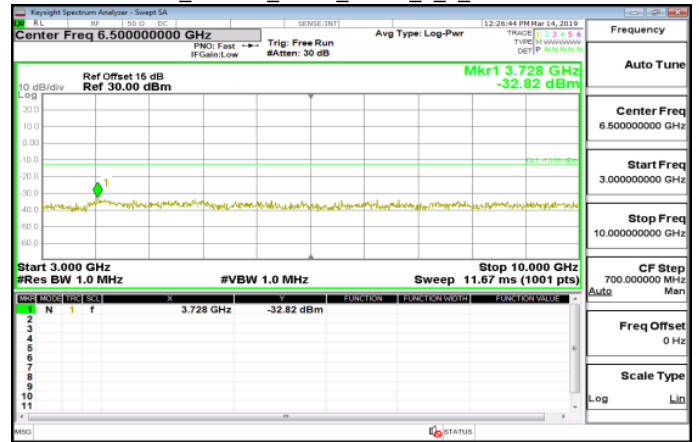

3GHz~10GHz_Band12_5MHz_QPSK_1_0_LowCH23035-701.5

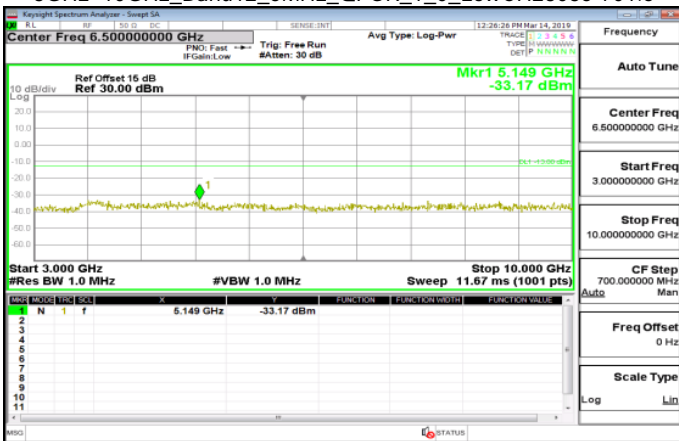

30MHz~3GHz_Band12_5MHz_QPSK_1_0_HighCH23155-713.5

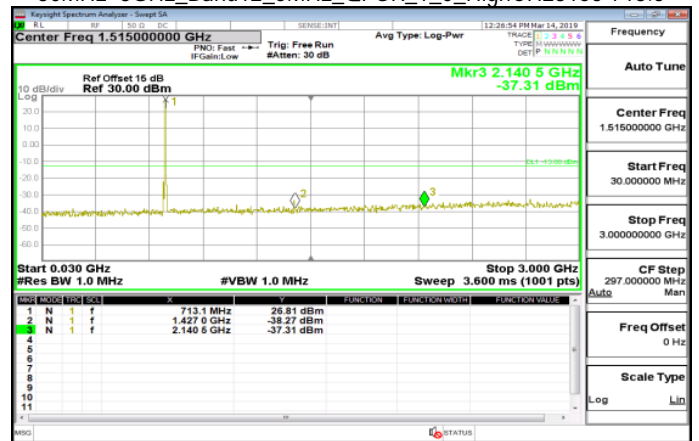

30MHz~3GHz_Band12_5MHz_QPSK_1_0_MidCH23095-707.5

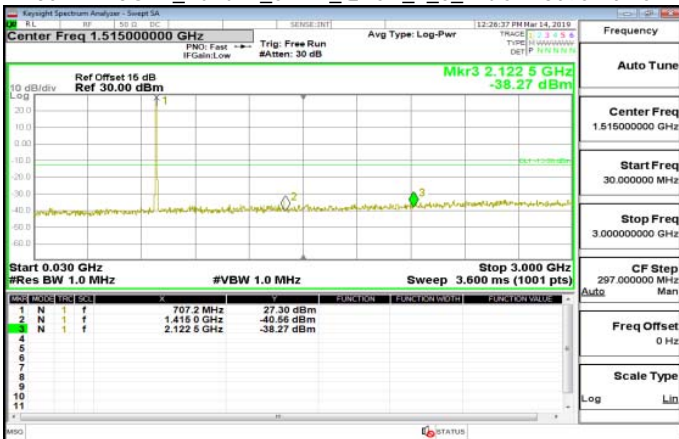

3GHz~10GHz_Band12_5MHz_QPSK_1_0_HighCH23155-713.5

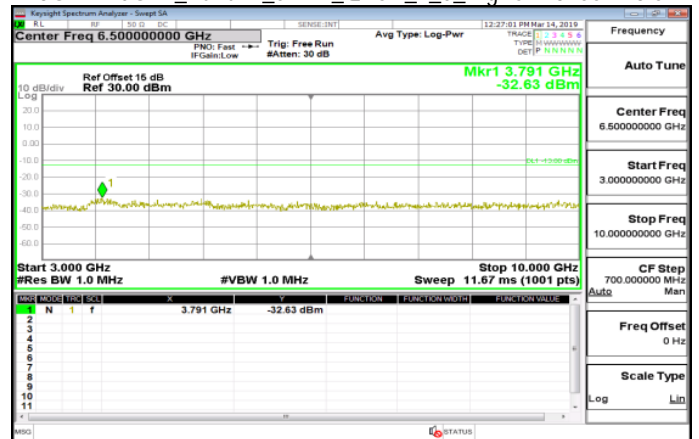

Unless otherwise stated the results shown in this test report refer only to the sample(s) tested and such sample(s) are retained for 90 days only.

除非另有說明，此報告結果僅對測試之樣品負責，同時此樣品僅保留90天。本報告未經本公司書面許可，不可部份複製。

This document is issued by the Company subject to its General Conditions of Service printed overleaf, available on request or accessible at www.sgs.com/terms_and_conditions.htm and for electronic format documents, subject to Terms and Conditions for Electronic Documents at www.sgs.com/terms_e-document.htm. Attention is drawn to the limitation of liability, indemnification and jurisdiction issues defined therein. Any holder of this document is advised that information contained hereon reflects the Company's findings at the time of its intervention only and within the limits of Client's instructions, if any. The Company's sole responsibility is to its Client and this document does not exonerate parties to a transaction from exercising all their rights and obligations under the transaction documents. This document cannot be reproduced except in full, without prior written approval of the Company. Any unauthorized alteration, forgery or falsification of the content or appearance of this document is unlawful and offenders may be prosecuted to the fullest extent of the law.

30MHz-3GHz_Band12_10MHz_QPSK_1_0_LowCH23060-704

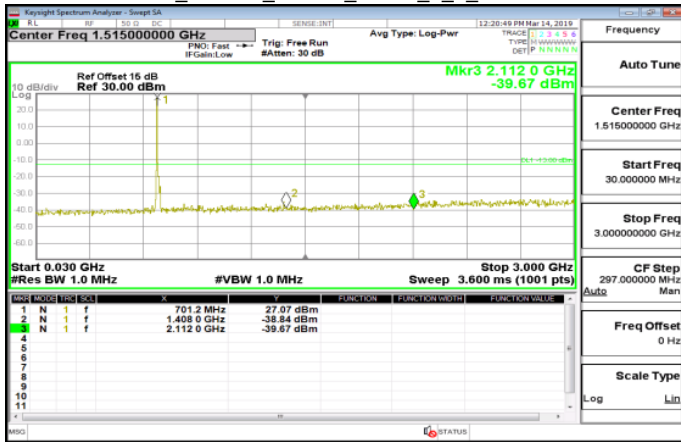

3GHz-10GHz_Band12_10MHz_QPSK_1_0_MidCH23095-707.5

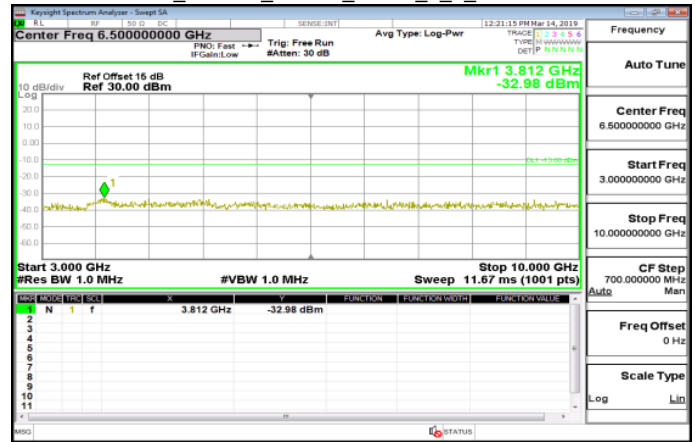

3GHz-10GHz_Band12_10MHz_QPSK_1_0_LowCH23060-704

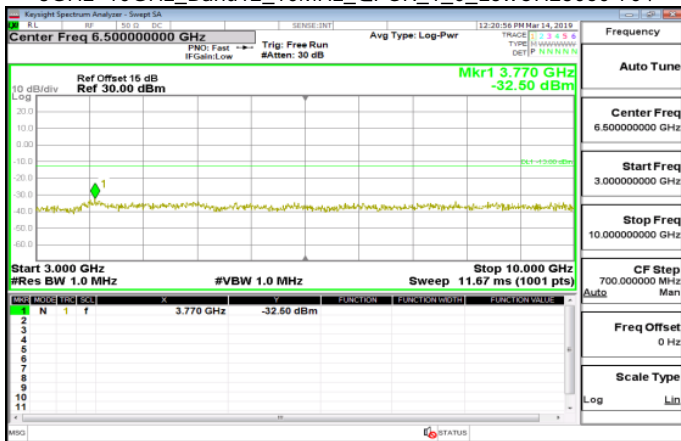

30MHz-3GHz_Band12_10MHz_QPSK_1_0_HighCH23130-711

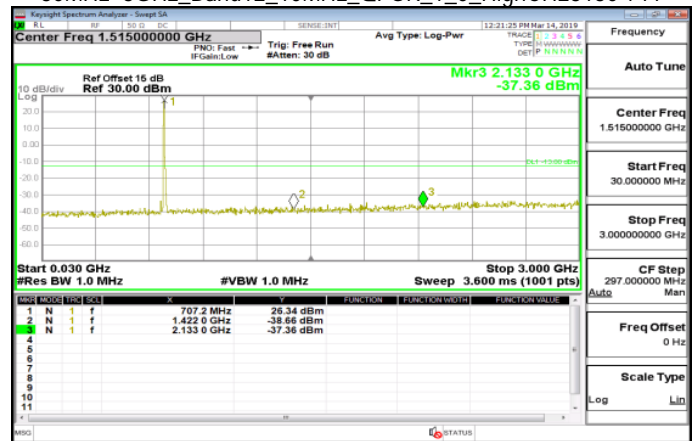

30MHz-3GHz_Band12_10MHz_QPSK_1_0_MidCH23095-707.5

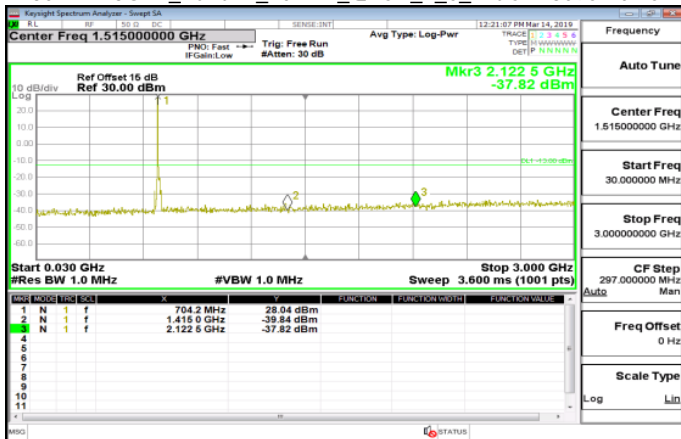

3GHz-10GHz_Band12_10MHz_QPSK_1_0_HighCH23130-711

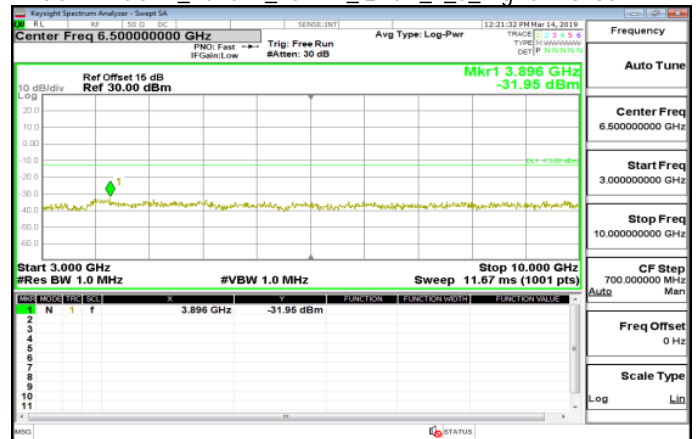

Unless otherwise stated the results shown in this test report refer only to the sample(s) tested and such sample(s) are retained for 90 days only.

除非另有說明，此報告結果僅對測試之樣品負責，同時此樣品僅保留90天。本報告未經本公司書面許可，不可部份複製。

This document is issued by the Company subject to its General Conditions of Service printed overleaf, available on request or accessible at www.sgs.com/terms_and_conditions.htm and for electronic format documents, subject to Terms and Conditions for Electronic Documents at www.sgs.com/terms_e-document.htm. Attention is drawn to the limitation of liability, indemnification and jurisdiction issues defined therein. Any holder of this document is advised that information contained hereon reflects the Company's findings at the time of its intervention only and within the limits of Client's instructions, if any. The Company's sole responsibility is to its Client and this document does not exonerate parties to a transaction from exercising all their rights and obligations under the transaction documents. This document cannot be reproduced except in full, without prior written approval of the Company. Any unauthorized alteration, forgery or falsification of the content or appearance of this document is unlawful and offenders may be prosecuted to the fullest extent of the law.

9. FIELD STRENGTH OF SPURIOUS RADIATION MEASUREMENT

9.1. Standard Applicable

According to FCC §2.1053,

FCC §22.917(a) , §24.238(a) , the magnitude of each spurious and harmonic emission that can be detected when the equipment is operated under the conditions specified in the instruction manual and/ or alignment procedure, shall not be less than $43 + 10 \log$ (mean output power in watts) dBc below the mean power output outside a license's frequency block (-13dBm).

FCC §27.53(g) (h)

Compliance with this provision is based on the use of measurement instrumentation employing a resolution bandwidth of 100 kilohertz or greater. However, in the 100 kilohertz bands immediately outside and adjacent to a licensee's frequency block, a resolution bandwidth of at least 30 kHz may be employed.

The power of any emission outside a licensee's frequency block shall be attenuated below the transmitter power (P) in watts by at least $43 + 10 \log_{10} (P)$ dB.

FCC §27.53(h) (3)

Compliance with this provision is based on the use of measurement instrumentation employing a resolution bandwidth of 1 megahertz or greater. However, in the 1 megahertz bands immediately outside and adjacent to the licensee's frequency block, a resolution bandwidth of at least one percent of the emission bandwidth of the fundamental emission of the transmitter may be employed. The emission bandwidth is defined as the width of the signal between two points, one below the carrier center frequency and one above the carrier center frequency, outside of which all emissions are attenuated at least 26 dB below the transmitter power.

Unless otherwise stated the results shown in this test report refer only to the sample(s) tested and such sample(s) are retained for 90 days only.

除非另有說明，此報告結果僅對測試之樣品負責，同時此樣品僅保留90天。本報告未經本公司書面許可，不可部份複製。

This document is issued by the Company subject to its General Conditions of Service printed overleaf, available on request or accessible at www.sgs.com/terms_and_conditions.htm and for electronic format documents, subject to Terms and Conditions for Electronic Documents at www.sgs.com/terms_e-document.htm. Attention is drawn to the limitation of liability, indemnification and jurisdiction issues defined therein. Any holder of this document is advised that information contained hereon reflects the Company's findings at the time of its intervention only and within the limits of Client's instructions, if any. The Company's sole responsibility is to its Client and this document does not exonerate parties to a transaction from exercising all their rights and obligations under the transaction documents. This document cannot be reproduced except in full, without prior written approval of the Company. Any unauthorized alteration, forgery or falsification of the content or appearance of this document is unlawful and offenders may be prosecuted to the fullest extent of the law.

Table 2 — Unwanted Emissions for Mobile, Portable and Low-Power Fixed Subscriber Equipment

Frequency (MHz)	Attenuation (dB)
<2200	$43 + 10 \log_{10}(p)$
2200 - 2288	$70 + 10 \log_{10}(p)$
2288 - 2292	$67 + 10 \log_{10}(p)$
2292 - 2296	$61 + 10 \log_{10}(p)$
2296 - 2300	$55 + 10 \log_{10}(p)$
2300 - 2305	$43 + 10 \log_{10}(p)$
2305 - 2320	$43 + 10 \log_{10}(p)$ ^{Note}
2320 - 2324	$55 + 10 \log_{10}(p)$
2324 - 2328	$61 + 10 \log_{10}(p)$
2328 - 2337	$67 + 10 \log_{10}(p)$
2337 - 2341	$61 + 10 \log_{10}(p)$
2341 - 2345	$55 + 10 \log_{10}(p)$
2345 - 2360	$43 + 10 \log_{10}(p)$ ^{Note}
2360 - 2365	$43 + 10 \log_{10}(p)$
2365 - 2395	$70 + 10 \log_{10}(p)$
>2395	$43 + 10 \log_{10}(p)$

Note: Measured at the edges of the highest and lowest frequency range(s) in which the equipment is designed to operate. See Section 1.2 for the permitted frequency ranges for various equipment types.

Unless otherwise stated the results shown in this test report refer only to the sample(s) tested and such sample(s) are retained for 90 days only.

除非另有說明，此報告結果僅對測試之樣品負責，同時此樣品僅保留90天。本報告未經本公司書面許可，不可部份複製。

This document is issued by the Company subject to its General Conditions of Service printed overleaf, available on request or accessible at www.sgs.com/terms_and_conditions.htm and for electronic format documents, subject to Terms and Conditions for Electronic Documents at www.sgs.com/terms_e-document.htm. Attention is drawn to the limitation of liability, indemnification and jurisdiction issues defined therein. Any holder of this document is advised that information contained hereon reflects the Company's findings at the time of its intervention only and within the limits of Client's instructions, if any. The Company's sole responsibility is to its Client and this document does not exonerate parties to a transaction from exercising all their rights and obligations under the transaction documents. This document cannot be reproduced except in full, without prior written approval of the Company. Any unauthorized alteration, forgery or falsification of the content or appearance of this document is unlawful and offenders may be prosecuted to the fullest extent of the law.

9.2. EUT Setup

Radiated Emission Test Set-Up, Frequency Below 1000MHz

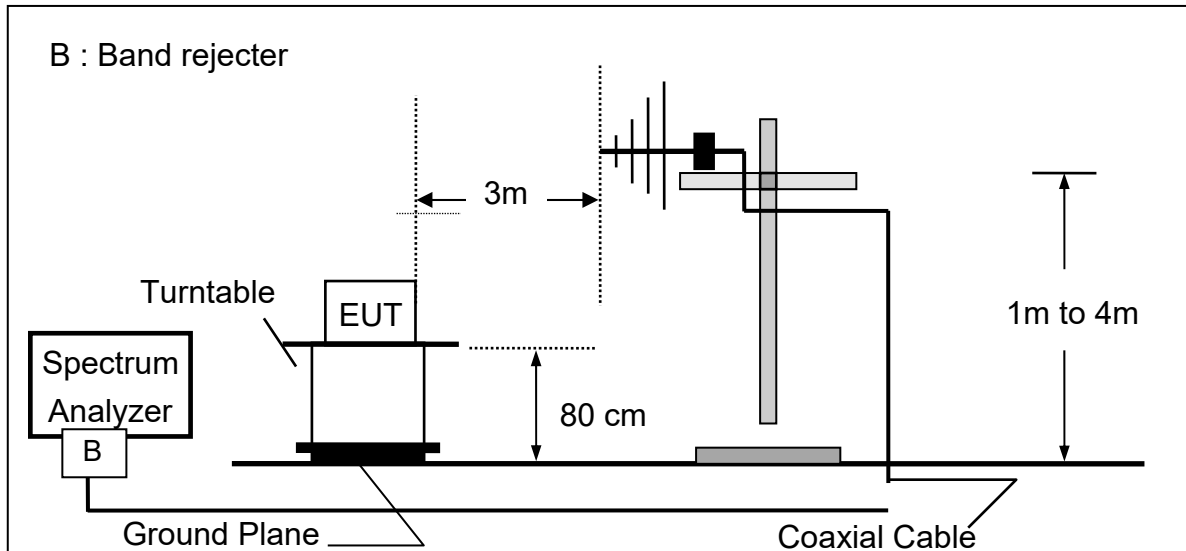

Radiated Emission Test Set-UP Frequency Over 1 GHz

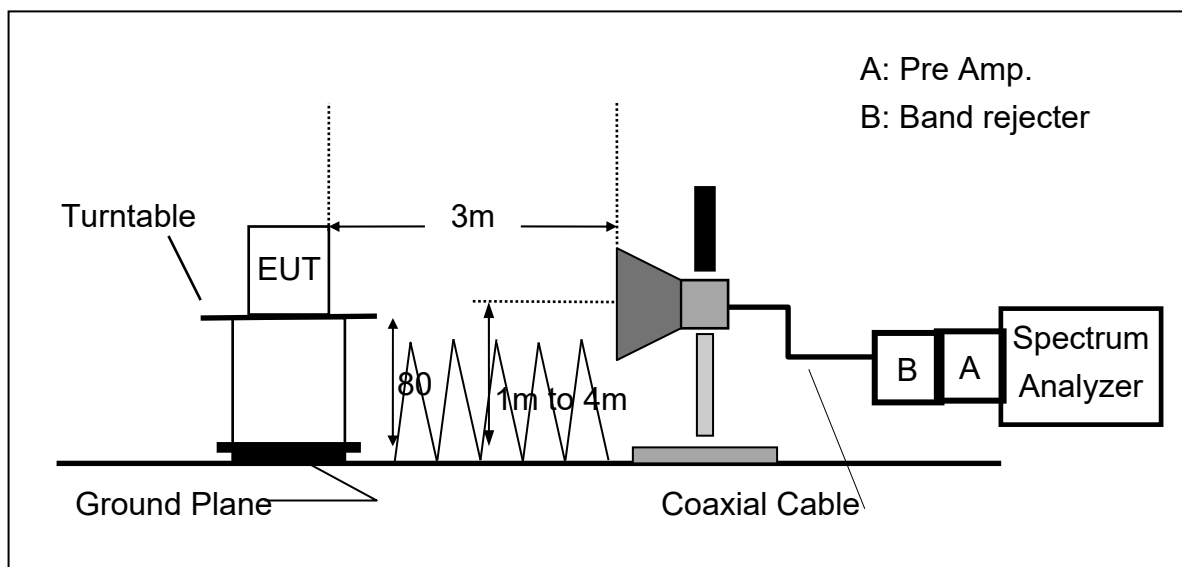

Unless otherwise stated the results shown in this test report refer only to the sample(s) tested and such sample(s) are retained for 90 days only.

除非另有說明，此報告結果僅對測試之樣品負責，同時此樣品僅保留90天。本報告未經本公司書面許可，不可部份複製。

This document is issued by the Company subject to its General Conditions of Service printed overleaf, available on request or accessible at www.sgs.com/terms_and_conditions.htm and for electronic format documents, subject to Terms and Conditions for Electronic Documents at www.sgs.com/terms_e-document.htm. Attention is drawn to the limitation of liability, indemnification and jurisdiction issues defined therein. Any holder of this document is advised that information contained hereon reflects the Company's findings at the time of its intervention only and within the limits of Client's instructions, if any. The Company's sole responsibility is to its Client and this document does not exonerate parties to a transaction from exercising all their rights and obligations under the transaction documents. This document cannot be reproduced except in full, without prior written approval of the Company. Any unauthorized alteration, forgery or falsification of the content or appearance of this document is unlawful and offenders may be prosecuted to the fullest extent of the law.

9.3. Measurement Procedure:

The EUT was placed on a non-conductive; the measurement antenna was placed at a distance of 3 meters from the EUT. During the tests, the antenna height and the EUT azimuth were varied in order to identify the maximum level of emissions from the EUT. This maximization process was repeated with the EUT positioned in each of its three orthogonal orientations.

The frequency range up to tenth harmonic was investigated for each of three fundamental frequencies (low, middle and high channels). Once spurious emission was identified, the power of the emission was determined using the substitution method.

The spurious emissions attenuation was calculated as the difference between radiated power at the fundamental frequency and the spurious emissions frequency.

ERP (dBm) = SG Level(dBm) + Antenna Gain(dBd) + Cable Loss(dB)

EIRP (dBm) = SG Level(dBm) + Antenna Gain(dBi) + Cable Loss(dB)

Unless otherwise stated the results shown in this test report refer only to the sample(s) tested and such sample(s) are retained for 90 days only.

除非另有說明，此報告結果僅對測試之樣品負責，同時此樣品僅保留90天。本報告未經本公司書面許可，不可部份複製。

This document is issued by the Company subject to its General Conditions of Service printed overleaf, available on request or accessible at www.sgs.com/terms_and_conditions.htm and for electronic format documents, subject to Terms and Conditions for Electronic Documents at www.sgs.com/terms_e-document.htm. Attention is drawn to the limitation of liability, indemnification and jurisdiction issues defined therein. Any holder of this document is advised that information contained hereon reflects the Company's findings at the time of its intervention only and within the limits of Client's instructions, if any. The Company's sole responsibility is to its Client and this document does not exonerate parties to a transaction from exercising all their rights and obligations under the transaction documents. This document cannot be reproduced except in full, without prior written approval of the Company. Any unauthorized alteration, forgery or falsification of the content or appearance of this document is unlawful and offenders may be prosecuted to the fullest extent of the law.

9.4. Measurement Equipment Used:

966A Chamber					
EQUIPMENT TYPE	MFR	MODEL NUMBER	SERIAL NUMBER	LAST CAL.	CAL DUE.
DC Power Supply	GWINSTEK	SPS-3610	GPE880163	01/14/2019	01/13/2020
PSA Series Spectrum Analyzer	Agilent	E4446A	MY46180323	05/31/2018	05/30/2019
Digital Thermo-Hygro Meter	WISEWIND	1206	D07	01/30/2019	01/29/2020
Pre-Amplifier	MITEQ	AMF-6F-260400-40-8P	985646	02/26/2019	02/25/2020
Pre-Amplifier	EMEC	EM330	60609	02/26/2019	02/25/2020
Pre-Amplifier	HP	8449B	3008A00965	02/26/2019	02/25/2020
Horn Antenna	Schwarzbeck	BBHA9170	184	12/27/2018	12/26/2019
Horn Antenna	ETS LINDGREN	3116	26370	12/26/2018	12/25/2019
Horn Antenna	SCHWARZBECK	BBHA 9120D	779	03/09/2019	03/08/2020
Bilog Antenna	Sunol Sciences	JB3	A030105	07/13/2018	07/12/2019
Bilog Antenna	Sunol Sciences	JB1	A052609	03/06/2019	03/05/2020
double Ridged Guide Horn Antenna	ETC	MCTD 1209	DRH13M02003	08/20/2018	08/19/2019
Loop Antenna	COM-POWER	AL-130	121051	03/22/2019	03/21/2020
Loop Antenna	ETS.LINDGREN	6502	148045	10/08/2018	10/07/2019
Attenuator	Marvelous	MVE2213-10	RF80	02/26/2019	02/25/2020
Radio Communication Analyer	Anritsu	MT8820C	6201465317	01/16/2019	01/15/2020
Cable	HUBER SUHNER	SUCOFLEX 104PEA	25157	02/26/2019	02/25/2020
Cable	HUBER SUHNER	SUCOFLEX 104PEA	20995	02/26/2019	02/25/2020
Notch Filter	EWT	EWT-54-0037	RF53	02/26/2019	02/25/2020
Notch Filter	EWT	EWT-54-0038	RF55	02/26/2019	02/25/2020
Software	e3 V6.11-20180413				

Unless otherwise stated the results shown in this test report refer only to the sample(s) tested and such sample(s) are retained for 90 days only.

除非另有說明，此報告結果僅對測試之樣品負責，同時此樣品僅保留90天。本報告未經本公司書面許可，不可部份複製。

This document is issued by the Company subject to its General Conditions of Service printed overleaf, available on request or accessible at www.sgs.com/terms_and_conditions.htm and for electronic format documents, subject to Terms and Conditions for Electronic Documents at www.sgs.com/terms_e-document.htm. Attention is drawn to the limitation of liability, indemnification and jurisdiction issues defined therein. Any holder of this document is advised that information contained hereon reflects the Company's findings at the time of its intervention only and within the limits of Client's instructions, if any. The Company's sole responsibility is to its Client and this document does not exonerate parties to a transaction from exercising all their rights and obligations under the transaction documents. This document cannot be reproduced except in full, without prior written approval of the Company. Any unauthorized alteration, forgery or falsification of the content or appearance of this document is unlawful and offenders may be prosecuted to the fullest extent of the law.

9.5. Measurement Result:

Radiated Spurious Emission Measurement Result: LTE-Band 2 (The Worst Case)

Project Number	:T190304W06	Test Date	:2019-05-30
Operation Band	:LTE B2 20 QPSK 1.0	Temp./Humi.	:22.7/56.3
Fundamental Frequency	:1860 MHz	Engineer	:Jerry
Operation Mode	:Tx CH Low	Measurement Antenna Pol.	:VERTICAL
EUT Pol.	:E2 Plan		

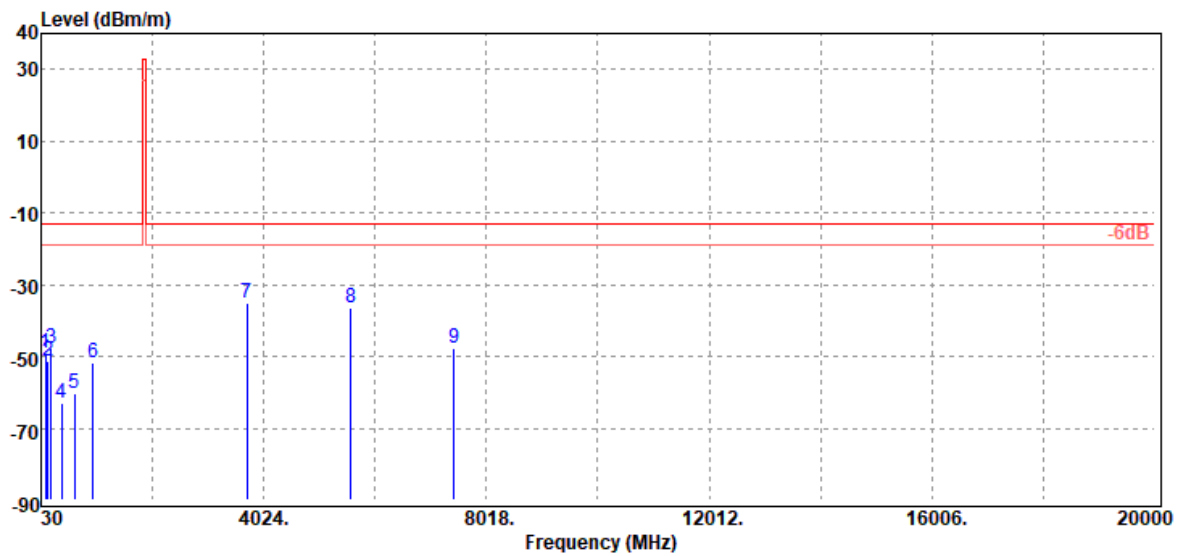

Freq. MHz	ERP/EIRP dBm	SG Output Level dBm	Antenna Gain dBd/dBi	Cable Loss dB	Limit dBm	Margin dB
104.69	-49.11	-39.03	-9.24	-0.84	-13.00	-36.11
149.31	-51.46	-43.29	-7.17	-1.00	-13.00	-38.46
216.24	-47.54	-44.25	-2.08	-1.21	-13.00	-34.54
401.51	-63.21	-59.82	-1.73	-1.66	-13.00	-50.21
624.61	-60.09	-56.58	-1.40	-2.11	-13.00	-47.09
958.29	-51.90	-48.01	-1.27	-2.62	-13.00	-38.90
3720.00	-35.30	-42.03	12.46	-5.73	-13.00	-22.30
5580.00	-36.43	-42.46	13.14	-7.11	-13.00	-23.43
7440.00	-47.52	-49.96	10.52	-8.08	-13.00	-34.52

Unless otherwise stated the results shown in this test report refer only to the sample(s) tested and such sample(s) are retained for 90 days only.

除非另有說明，此報告結果僅對測試之樣品負責，同時此樣品僅保留90天。本報告未經本公司書面許可，不可部份複製。

This document is issued by the Company subject to its General Conditions of Service printed overleaf, available on request or accessible at www.sgs.com/terms_and_conditions.htm and for electronic format documents, subject to Terms and Conditions for Electronic Documents at www.sgs.com/terms_e-document.htm. Attention is drawn to the limitation of liability, indemnification and jurisdiction issues defined therein. Any holder of this document is advised that information contained hereon reflects the Company's findings at the time of its intervention only and within the limits of Client's instructions, if any. The Company's sole responsibility is to its Client and this document does not exonerate parties to a transaction from exercising all their rights and obligations under the transaction documents. This document cannot be reproduced except in full, without prior written approval of the Company. Any unauthorized alteration, forgery or falsification of the content or appearance of this document is unlawful and offenders may be prosecuted to the fullest extent of the law.

Project Number :T190304W06
 Operation Band :LTE B2 20 QPSK 1.0
 Fundamental Frequency :1860 MHz
 Operation Mode :Tx CH Low
 EUT Pol. :E2 Plan

Test Date :2019-05-30
 Temp./Humi. :22.7/56.3
 Engineer :Jerry
 Measurement Antenna Pol. :HORIZONTAL

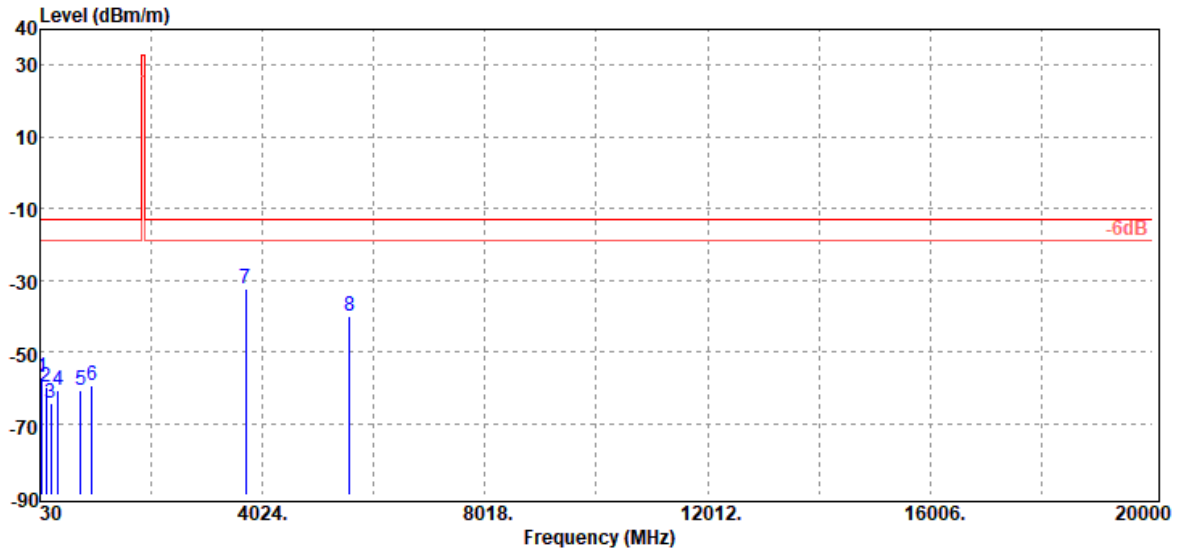

Freq. MHz	ERP/EIRP dBm	SG Output Level dBm	Antenna Gain dBd/dBi	Cable Loss dB	Limit dBm	Margin dB
70.74	-57.20	-46.91	-9.60	-0.69	-13.00	-44.20
136.70	-59.88	-49.86	-9.06	-0.96	-13.00	-46.88
219.15	-64.30	-61.06	-2.02	-1.22	-13.00	-51.30
354.95	-60.60	-57.64	-1.40	-1.56	-13.00	-47.60
760.41	-60.98	-57.26	-1.40	-2.32	-13.00	-47.98
958.29	-59.39	-55.5	-1.27	-2.62	-13.00	-46.39
3720.00	-32.24	-38.97	12.46	-5.73	-13.00	-19.24
5580.00	-40.21	-46.24	13.14	-7.11	-13.00	-27.21

Unless otherwise stated the results shown in this test report refer only to the sample(s) tested and such sample(s) are retained for 90 days only.

除非另有說明，此報告結果僅對測試之樣品負責，同時此樣品僅保留90天。本報告未經本公司書面許可，不可部份複製。

This document is issued by the Company subject to its General Conditions of Service printed overleaf, available on request or accessible at www.sgs.com/terms_and_conditions.htm and for electronic format documents, subject to Terms and Conditions for Electronic Documents at www.sgs.com/terms_e-document.htm. Attention is drawn to the limitation of liability, indemnification and jurisdiction issues defined therein. Any holder of this document is advised that information contained hereon reflects the Company's findings at the time of its intervention only and within the limits of Client's instructions, if any. The Company's sole responsibility is to its Client and this document does not exonerate parties to a transaction from exercising all their rights and obligations under the transaction documents. This document cannot be reproduced except in full, without prior written approval of the Company. Any unauthorized alteration, forgery or falsification of the content or appearance of this document is unlawful and offenders may be prosecuted to the fullest extent of the law.

Project Number :T190304W06
 Operation Band :LTE B2 20 QPSK 1.0
 Fundamental Frequency :1880 MHz
 Operation Mode :Tx CH Mid
 EUT Pol. :E2 Plan

Test Date :2019-05-30
 Temp./Humi. :22.7/56.3
 Engineer :Jerry
 Measurement Antenna Pol. :VERTICAL

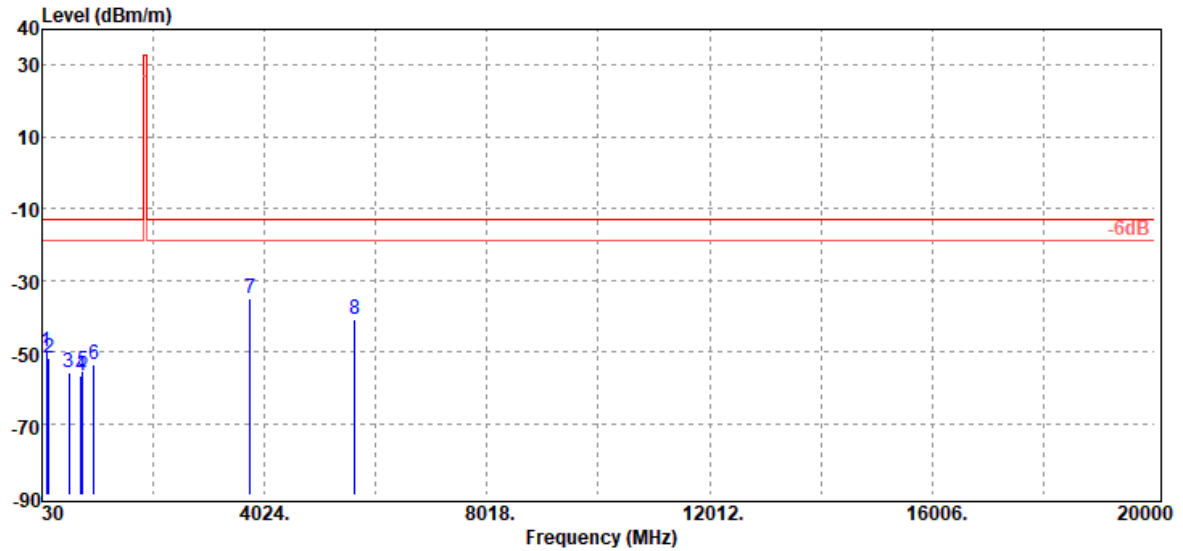

Freq. MHz	ERP/EIRP dBm	SG Output Level dBm	Antenna Gain dBd/dBi	Cable Loss dB	Limit dBm	Margin dB
104.69	-50.04	-39.96	-9.24	-0.84	-13.00	-37.04
149.31	-51.92	-43.75	-7.17	-1.00	-13.00	-38.92
519.85	-55.74	-52.43	-1.40	-1.91	-13.00	-42.74
730.34	-56.64	-52.97	-1.39	-2.28	-13.00	-43.64
760.41	-55.15	-51.43	-1.40	-2.32	-13.00	-42.15
958.29	-53.45	-49.56	-1.27	-2.62	-13.00	-40.45
3760.00	-35.11	-41.77	12.42	-5.76	-13.00	-22.11
5640.00	-41.03	-47.15	13.26	-7.14	-13.00	-28.03

Unless otherwise stated the results shown in this test report refer only to the sample(s) tested and such sample(s) are retained for 90 days only.

除非另有說明，此報告結果僅對測試之樣品負責，同時此樣品僅保留90天。本報告未經本公司書面許可，不可部份複製。

This document is issued by the Company subject to its General Conditions of Service printed overleaf, available on request or accessible at www.sgs.com/terms_and_conditions.htm and for electronic format documents, subject to Terms and Conditions for Electronic Documents at www.sgs.com/terms_e-document.htm. Attention is drawn to the limitation of liability, indemnification and jurisdiction issues defined therein. Any holder of this document is advised that information contained hereon reflects the Company's findings at the time of its intervention only and within the limits of Client's instructions, if any. The Company's sole responsibility is to its Client and this document does not exonerate parties to a transaction from exercising all their rights and obligations under the transaction documents. This document cannot be reproduced except in full, without prior written approval of the Company. Any unauthorized alteration, forgery or falsification of the content or appearance of this document is unlawful and offenders may be prosecuted to the fullest extent of the law.

Project Number :T190304W06
 Operation Band :LTE B2 20 QPSK 1.0
 Fundamental Frequency :1880 MHz
 Operation Mode :Tx CH Mid
 EUT Pol. :E2 Plan

Test Date :2019-05-30
 Temp./Humi. :22.7/56.3
 Engineer :Jerry
 Measurement Antenna Pol. :HORIZONTAL

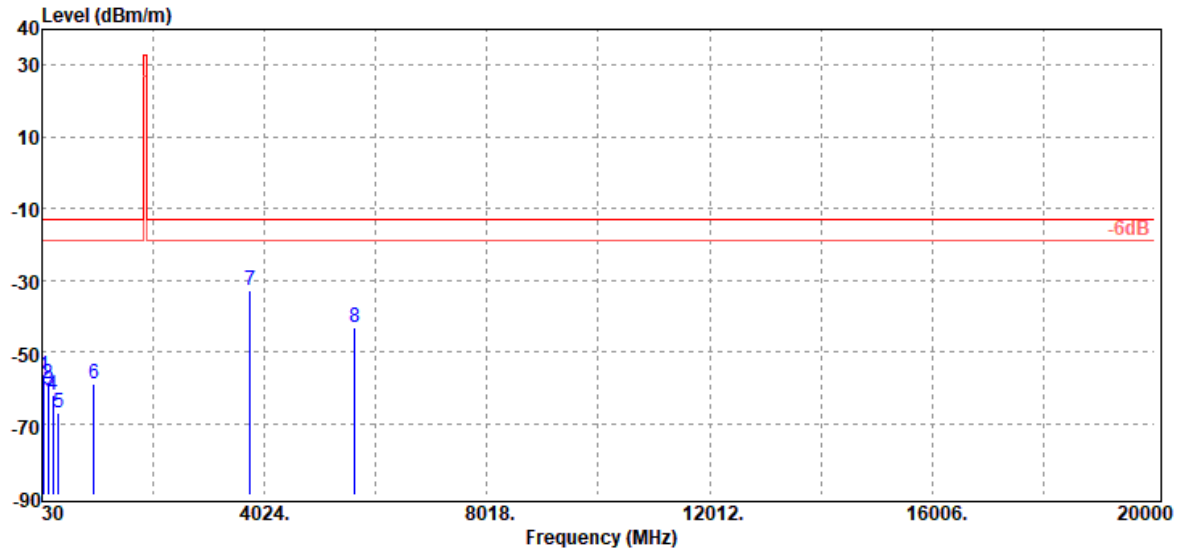

Freq. MHz	ERP/EIRP dBm	SG Output Level dBm	Antenna Gain dBd/dBi	Cable Loss dB	Limit dBm	Margin dB
69.77	-56.78	-46.44	-9.65	-0.69	-13.00	-43.78
137.67	-58.83	-49	-8.87	-0.96	-13.00	-45.83
151.25	-60.67	-52.61	-7.05	-1.01	-13.00	-47.67
225.94	-62.02	-58.85	-1.94	-1.23	-13.00	-49.02
327.79	-66.99	-63.75	-1.74	-1.50	-13.00	-53.99
956.35	-58.82	-54.97	-1.23	-2.62	-13.00	-45.82
3760.00	-32.80	-39.46	12.42	-5.76	-13.00	-19.80
5640.00	-43.21	-49.33	13.26	-7.14	-13.00	-30.21

Unless otherwise stated the results shown in this test report refer only to the sample(s) tested and such sample(s) are retained for 90 days only.

除非另有說明，此報告結果僅對測試之樣品負責，同時此樣品僅保留90天。本報告未經本公司書面許可，不可部份複製。

This document is issued by the Company subject to its General Conditions of Service printed overleaf, available on request or accessible at www.sgs.com/terms_and_conditions.htm and for electronic format documents, subject to Terms and Conditions for Electronic Documents at www.sgs.com/terms_e-document.htm. Attention is drawn to the limitation of liability, indemnification and jurisdiction issues defined therein. Any holder of this document is advised that information contained hereon reflects the Company's findings at the time of its intervention only and within the limits of Client's instructions, if any. The Company's sole responsibility is to its Client and this document does not exonerate parties to a transaction from exercising all their rights and obligations under the transaction documents. This document cannot be reproduced except in full, without prior written approval of the Company. Any unauthorized alteration, forgery or falsification of the content or appearance of this document is unlawful and offenders may be prosecuted to the fullest extent of the law.

Project Number :T190304W06
 Operation Band :LTE B2 20 QPSK 1.0
 Fundamental Frequency :1900 MHz
 Operation Mode :Tx CH High
 EUT Pol. :E2 Plan

Test Date :2019-05-30
 Temp./Humi. :22.7/56.3
 Engineer :Jerry
 Measurement Antenna Pol. :VERTICAL

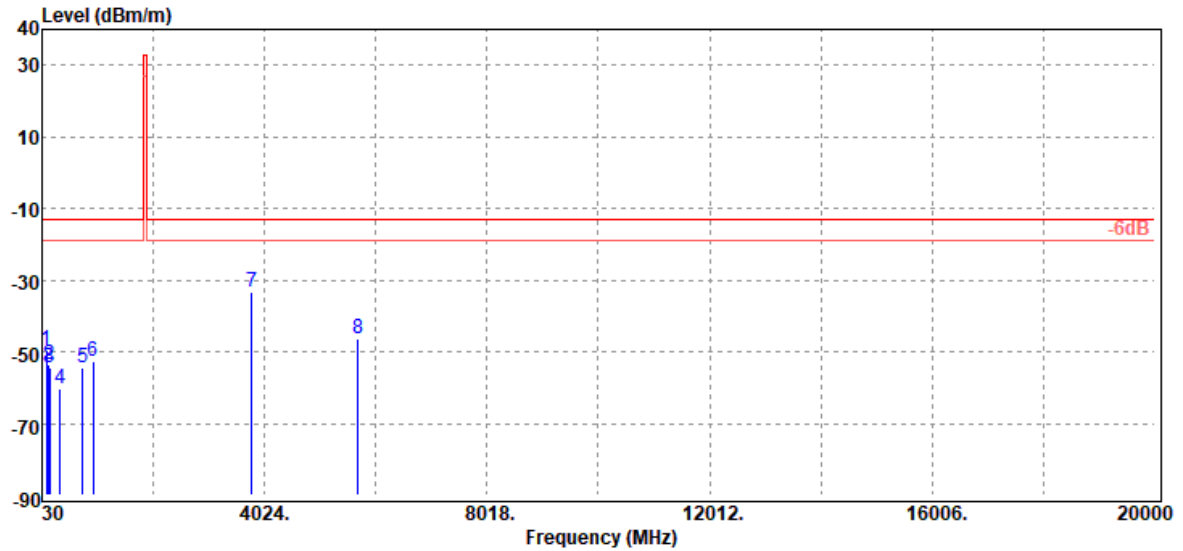

Freq. MHz	ERP/EIRP dBm	SG Output Level dBm	Antenna Gain dBd/dBi	Cable Loss dB	Limit dBm	Margin dB
104.69	-49.57	-39.49	-9.24	-0.84	-13.00	-36.57
151.25	-53.47	-45.41	-7.05	-1.01	-13.00	-40.47
170.65	-54.67	-48.27	-5.33	-1.07	-13.00	-41.67
352.04	-60.49	-57.48	-1.46	-1.55	-13.00	-47.49
760.41	-54.56	-50.84	-1.40	-2.32	-13.00	-41.56
951.50	-52.84	-49.02	-1.20	-2.62	-13.00	-39.84
3800.00	-33.15	-39.86	12.50	-5.79	-13.00	-20.15
5700.00	-46.52	-52.45	13.10	-7.17	-13.00	-33.52

Unless otherwise stated the results shown in this test report refer only to the sample(s) tested and such sample(s) are retained for 90 days only.

除非另有說明，此報告結果僅對測試之樣品負責，同時此樣品僅保留90天。本報告未經本公司書面許可，不可部份複製。

This document is issued by the Company subject to its General Conditions of Service printed overleaf, available on request or accessible at www.sgs.com/terms_and_conditions.htm and for electronic format documents, subject to Terms and Conditions for Electronic Documents at www.sgs.com/terms_e-document.htm. Attention is drawn to the limitation of liability, indemnification and jurisdiction issues defined therein. Any holder of this document is advised that information contained hereon reflects the Company's findings at the time of its intervention only and within the limits of Client's instructions, if any. The Company's sole responsibility is to its Client and this document does not exonerate parties to a transaction from exercising all their rights and obligations under the transaction documents. This document cannot be reproduced except in full, without prior written approval of the Company. Any unauthorized alteration, forgery or falsification of the content or appearance of this document is unlawful and offenders may be prosecuted to the fullest extent of the law.

Project Number :T190304W06
 Operation Band :LTE B2 20 QPSK 1.0
 Fundamental Frequency :1900 MHz
 Operation Mode :Tx CH High
 EUT Pol. :E2 Plan

Test Date :2019-05-30
 Temp./Humi. :22.7/56.3
 Engineer :Jerry
 Measurement Antenna Pol. :HORIZONTAL

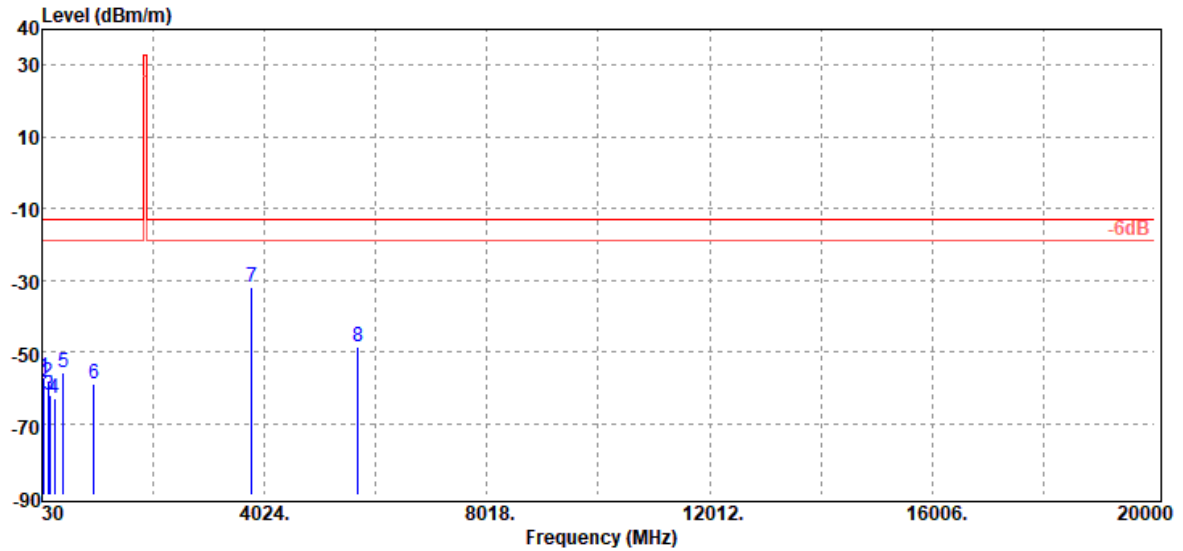

Freq. MHz	ERP/EIRP dBm	SG Output Level dBm	Antenna Gain dBd/dBi	Cable Loss dB	Limit dBm	Margin dB
70.74	-56.99	-46.7	-9.60	-0.69	-13.00	-43.99
133.79	-58.52	-48.05	-9.52	-0.95	-13.00	-45.52
165.80	-62.11	-55.31	-5.74	-1.06	-13.00	-49.11
256.01	-63.11	-60.15	-1.64	-1.32	-13.00	-50.11
416.06	-55.98	-52.39	-1.90	-1.69	-13.00	-42.98
958.29	-58.86	-54.97	-1.27	-2.62	-13.00	-45.86
3800.00	-32.01	-38.72	12.50	-5.79	-13.00	-19.01
5700.00	-48.80	-54.73	13.10	-7.17	-13.00	-35.80

Unless otherwise stated the results shown in this test report refer only to the sample(s) tested and such sample(s) are retained for 90 days only.

除非另有說明，此報告結果僅對測試之樣品負責，同時此樣品僅保留90天。本報告未經本公司書面許可，不可部份複製。

This document is issued by the Company subject to its General Conditions of Service printed overleaf, available on request or accessible at www.sgs.com/terms_and_conditions.htm and for electronic format documents, subject to Terms and Conditions for Electronic Documents at www.sgs.com/terms_e-document.htm. Attention is drawn to the limitation of liability, indemnification and jurisdiction issues defined therein. Any holder of this document is advised that information contained hereon reflects the Company's findings at the time of its intervention only and within the limits of Client's instructions, if any. The Company's sole responsibility is to its Client and this document does not exonerate parties to a transaction from exercising all their rights and obligations under the transaction documents. This document cannot be reproduced except in full, without prior written approval of the Company. Any unauthorized alteration, forgery or falsification of the content or appearance of this document is unlawful and offenders may be prosecuted to the fullest extent of the law.

Radiated Spurious Emission Measurement Result: LTE-Band 4 (The Worst Case)

Project Number	:T190304W06	Test Date	:2019-05-30
Operation Band	:LTE B4 20 QPSK 1.0	Temp./Humi.	:22.7/56.3
Fundamental Frequency	:1720 MHz	Engineer	:Jerry
Operation Mode	:Tx CH Low	Measurement Antenna Pol.	:VERTICAL
EUT Pol.	:E2 Plan		

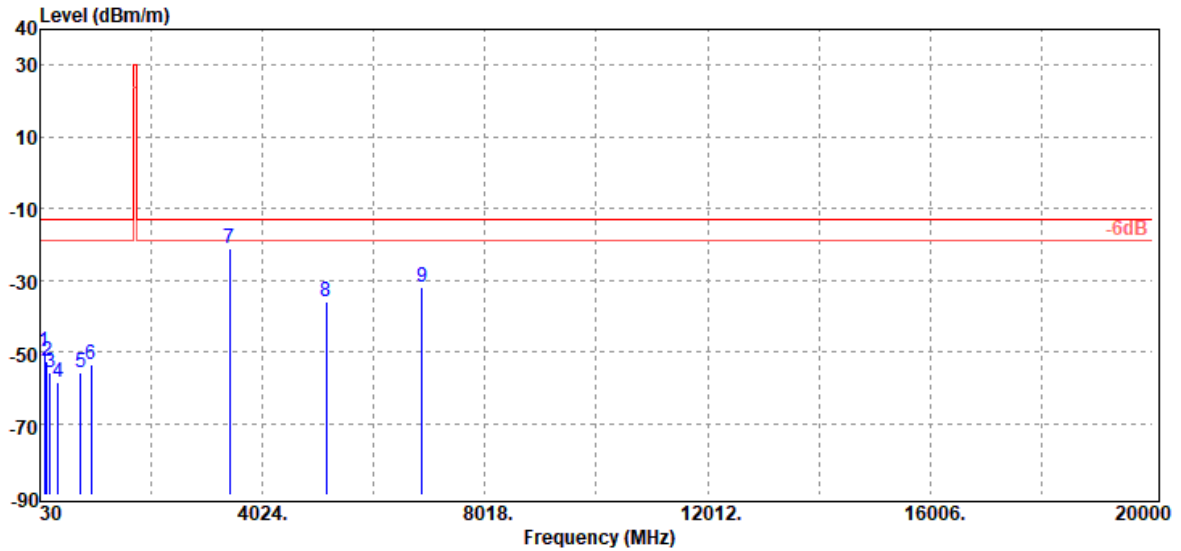

Freq. MHz	ERP/EIRP dBm	SG Output Level dBm	Antenna Gain dBd/dBi	Cable Loss dB	Limit dBm	Margin dB
104.69	-49.85	-39.77	-9.24	-0.84	-13.00	-36.85
150.28	-52.75	-44.64	-7.10	-1.01	-13.00	-39.75
206.54	-55.87	-52.11	-2.58	-1.18	-13.00	-42.87
350.10	-58.69	-55.64	-1.50	-1.55	-13.00	-45.69
760.41	-55.98	-52.26	-1.40	-2.32	-13.00	-42.98
951.50	-53.62	-49.8	-1.20	-2.62	-13.00	-40.62
3440.00	-21.11	-28.32	12.72	-5.51	-13.00	-8.11
5160.00	-36.08	-42.13	12.76	-6.71	-13.00	-23.08
6880.00	-32.11	-35.8	11.56	-7.87	-13.00	-19.11

Unless otherwise stated the results shown in this test report refer only to the sample(s) tested and such sample(s) are retained for 90 days only.

除非另有說明，此報告結果僅對測試之樣品負責，同時此樣品僅保留90天。本報告未經本公司書面許可，不可部份複製。

This document is issued by the Company subject to its General Conditions of Service printed overleaf, available on request or accessible at www.sgs.com/terms_and_conditions.htm and for electronic format documents, subject to Terms and Conditions for Electronic Documents at www.sgs.com/terms_e-document.htm. Attention is drawn to the limitation of liability, indemnification and jurisdiction issues defined therein. Any holder of this document is advised that information contained hereon reflects the Company's findings at the time of its intervention only and within the limits of Client's instructions, if any. The Company's sole responsibility is to its Client and this document does not exonerate parties to a transaction from exercising all their rights and obligations under the transaction documents. This document cannot be reproduced except in full, without prior written approval of the Company. Any unauthorized alteration, forgery or falsification of the content or appearance of this document is unlawful and offenders may be prosecuted to the fullest extent of the law.

Project Number :T190304W06
 Operation Band :LTE B4 20 QPSK 1.0
 Fundamental Frequency :1720 MHz
 Operation Mode :Tx CH Low
 EUT Pol. :E2 Plan

Test Date :2019-05-30
 Temp./Humi. :22.7/56.3
 Engineer :Jerry
 Measurement Antenna Pol. :HORIZONTAL

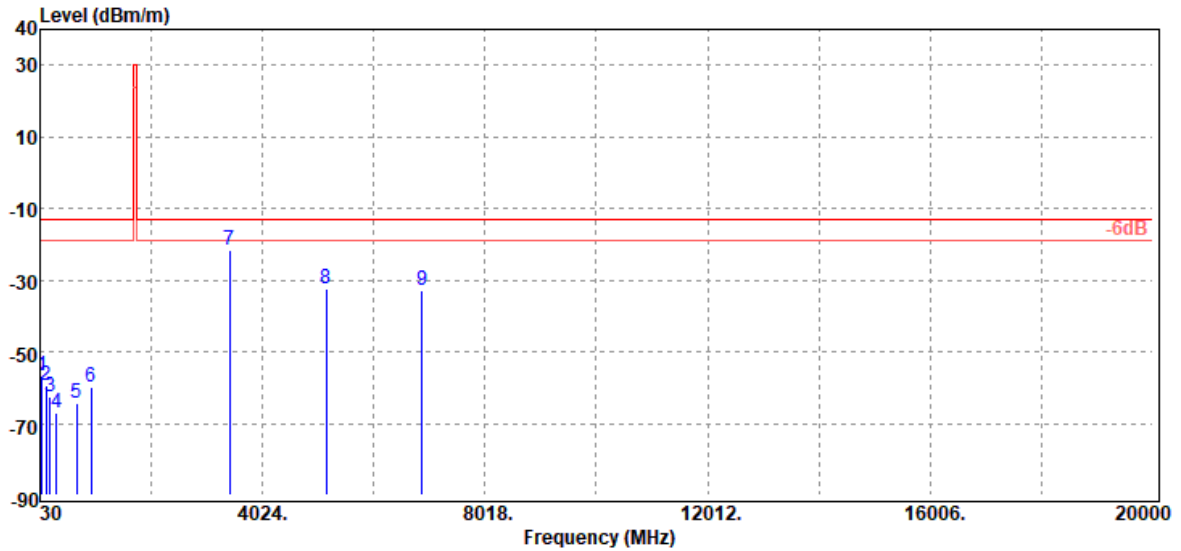

Freq. MHz	ERP/EIRP dBm	SG Output Level dBm	Antenna Gain dBd/dBi	Cable Loss dB	Limit dBm	Margin dB
70.74	-56.74	-46.45	-9.60	-0.69	-13.00	-43.74
134.76	-59.57	-49.27	-9.35	-0.95	-13.00	-46.57
212.36	-62.64	-59.34	-2.10	-1.20	-13.00	-49.64
332.64	-67.06	-63.9	-1.65	-1.51	-13.00	-54.06
686.69	-64.16	-60.62	-1.33	-2.21	-13.00	-51.16
954.41	-59.72	-55.9	-1.20	-2.62	-13.00	-46.72
3440.00	-21.79	-29	12.72	-5.51	-13.00	-8.79
5160.00	-32.64	-38.69	12.76	-6.71	-13.00	-19.64
6880.00	-32.75	-36.44	11.56	-7.87	-13.00	-19.75

Unless otherwise stated the results shown in this test report refer only to the sample(s) tested and such sample(s) are retained for 90 days only.

除非另有說明，此報告結果僅對測試之樣品負責，同時此樣品僅保留90天。本報告未經本公司書面許可，不可部份複製。

This document is issued by the Company subject to its General Conditions of Service printed overleaf, available on request or accessible at www.sgs.com/terms_and_conditions.htm and for electronic format documents, subject to Terms and Conditions for Electronic Documents at www.sgs.com/terms_e-document.htm. Attention is drawn to the limitation of liability, indemnification and jurisdiction issues defined therein. Any holder of this document is advised that information contained hereon reflects the Company's findings at the time of its intervention only and within the limits of Client's instructions, if any. The Company's sole responsibility is to its Client and this document does not exonerate parties to a transaction from exercising all their rights and obligations under the transaction documents. This document cannot be reproduced except in full, without prior written approval of the Company. Any unauthorized alteration, forgery or falsification of the content or appearance of this document is unlawful and offenders may be prosecuted to the fullest extent of the law.

Project Number :T190304W06
 Operation Band :LTE B4 20 QPSK 1.0
 Fundamental Frequency :1732.5 MHz
 Operation Mode :Tx CH Mid
 EUT Pol. :E2 Plan

Test Date :2019-05-30
 Temp./Humi. :22.7/56.3
 Engineer :Jerry
 Measurement Antenna Pol. :VERTICAL

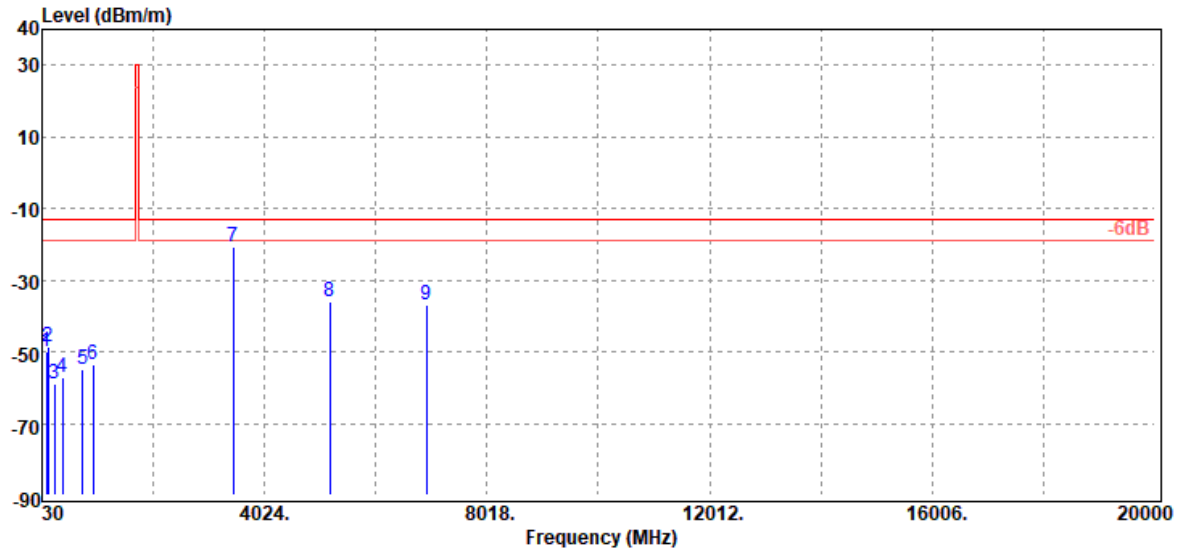

Freq. MHz	ERP/EIRP dBm	SG Output Level dBm	Antenna Gain dBd/dBi	Cable Loss dB	Limit dBm	Margin dB
104.69	-50.04	-39.96	-9.24	-0.84	-13.00	-37.04
141.55	-48.81	-39.53	-8.30	-0.98	-13.00	-35.81
255.04	-58.82	-55.91	-1.60	-1.31	-13.00	-45.82
400.54	-57.04	-53.67	-1.71	-1.66	-13.00	-44.04
760.41	-54.72	-51	-1.40	-2.32	-13.00	-41.72
951.50	-53.62	-49.8	-1.20	-2.62	-13.00	-40.62
3465.00	-20.86	-27.97	12.64	-5.53	-13.00	-7.86
5197.50	-35.99	-42.22	12.98	-6.75	-13.00	-22.99
6930.00	-37.10	-40.54	11.34	-7.90	-13.00	-24.10

Unless otherwise stated the results shown in this test report refer only to the sample(s) tested and such sample(s) are retained for 90 days only.

除非另有說明，此報告結果僅對測試之樣品負責，同時此樣品僅保留90天。本報告未經本公司書面許可，不可部份複製。

This document is issued by the Company subject to its General Conditions of Service printed overleaf, available on request or accessible at www.sgs.com/terms_and_conditions.htm and for electronic format documents, subject to Terms and Conditions for Electronic Documents at www.sgs.com/terms_e-document.htm. Attention is drawn to the limitation of liability, indemnification and jurisdiction issues defined therein. Any holder of this document is advised that information contained hereon reflects the Company's findings at the time of its intervention only and within the limits of Client's instructions, if any. The Company's sole responsibility is to its Client and this document does not exonerate parties to a transaction from exercising all their rights and obligations under the transaction documents. This document cannot be reproduced except in full, without prior written approval of the Company. Any unauthorized alteration, forgery or falsification of the content or appearance of this document is unlawful and offenders may be prosecuted to the fullest extent of the law.

Project Number :T190304W06
 Operation Band :LTE B4 20 QPSK 1.0
 Fundamental Frequency :1745 MHz
 Operation Mode :Tx CH High
 EUT Pol. :E2 Plan

Test Date :2019-05-30
 Temp./Humi. :22.7/56.3
 Engineer :Jerry
 Measurement Antenna Pol. :VERTICAL

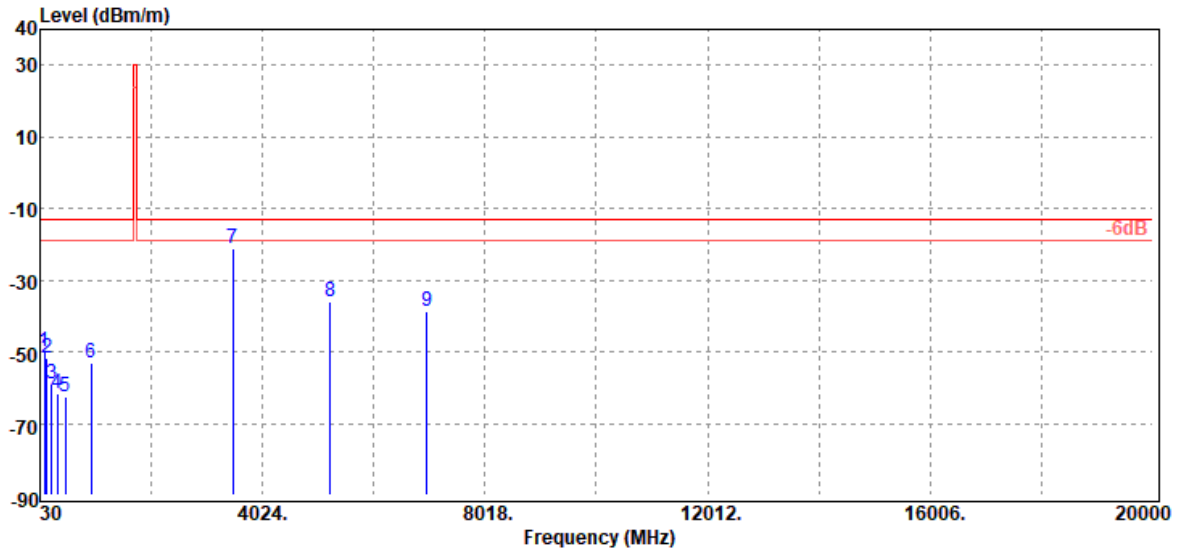

Freq. MHz	ERP/EIRP dBm	SG Output Level dBm	Antenna Gain dBd/dBi	Cable Loss dB	Limit dBm	Margin dB
104.69	-49.87	-39.79	-9.24	-0.84	-13.00	-36.87
151.25	-51.61	-43.55	-7.05	-1.01	-13.00	-38.61
243.40	-59.02	-55.78	-1.96	-1.28	-13.00	-46.02
338.46	-61.74	-58.69	-1.53	-1.52	-13.00	-48.74
479.11	-62.69	-58.47	-2.40	-1.82	-13.00	-49.69
951.50	-53.24	-49.42	-1.20	-2.62	-13.00	-40.24
3490.00	-20.97	-27.96	12.54	-5.55	-13.00	-7.97
5235.00	-35.97	-42.32	13.14	-6.79	-13.00	-22.97
6980.00	-38.86	-42.05	11.12	-7.93	-13.00	-25.86

Unless otherwise stated the results shown in this test report refer only to the sample(s) tested and such sample(s) are retained for 90 days only.

除非另有說明，此報告結果僅對測試之樣品負責，同時此樣品僅保留90天。本報告未經本公司書面許可，不可部份複製。

This document is issued by the Company subject to its General Conditions of Service printed overleaf, available on request or accessible at www.sgs.com/terms_and_conditions.htm and for electronic format documents, subject to Terms and Conditions for Electronic Documents at www.sgs.com/terms_e-document.htm. Attention is drawn to the limitation of liability, indemnification and jurisdiction issues defined therein. Any holder of this document is advised that information contained hereon reflects the Company's findings at the time of its intervention only and within the limits of Client's instructions, if any. The Company's sole responsibility is to its Client and this document does not exonerate parties to a transaction from exercising all their rights and obligations under the transaction documents. This document cannot be reproduced except in full, without prior written approval of the Company. Any unauthorized alteration, forgery or falsification of the content or appearance of this document is unlawful and offenders may be prosecuted to the fullest extent of the law.

Project Number :T190304W06
 Operation Band :LTE B4 20 QPSK 1.0
 Fundamental Frequency :1745 MHz
 Operation Mode :Tx CH High
 EUT Pol. :E2 Plan

Test Date :2019-05-30
 Temp./Humi. :22.7/56.3
 Engineer :Jerry
 Measurement Antenna Pol. :HORIZONTAL

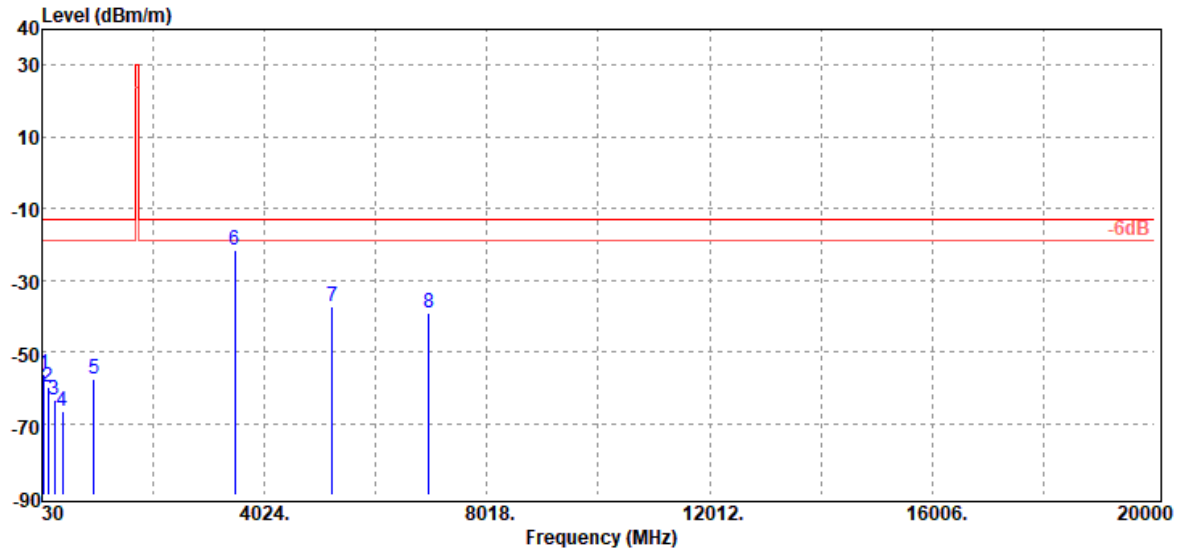

Freq. MHz	ERP/EIRP dBm	SG Output Level dBm	Antenna Gain dBd/dBi	Cable Loss dB	Limit dBm	Margin dB
59.10	-56.08	-45.14	-10.31	-0.63	-13.00	-43.08
133.79	-59.64	-49.17	-9.52	-0.95	-13.00	-46.64
255.04	-63.34	-60.43	-1.60	-1.31	-13.00	-50.34
396.66	-66.61	-63.33	-1.63	-1.65	-13.00	-53.61
958.29	-57.48	-53.59	-1.27	-2.62	-13.00	-44.48
3490.00	-21.83	-28.82	12.54	-5.55	-13.00	-8.83
5235.00	-37.40	-43.75	13.14	-6.79	-13.00	-24.40
6980.00	-39.07	-42.26	11.12	-7.93	-13.00	-26.07

Unless otherwise stated the results shown in this test report refer only to the sample(s) tested and such sample(s) are retained for 90 days only.

除非另有說明，此報告結果僅對測試之樣品負責，同時此樣品僅保留90天。本報告未經本公司書面許可，不可部份複製。

This document is issued by the Company subject to its General Conditions of Service printed overleaf, available on request or accessible at www.sgs.com/terms_and_conditions.htm and for electronic format documents, subject to Terms and Conditions for Electronic Documents at www.sgs.com/terms_e-document.htm. Attention is drawn to the limitation of liability, indemnification and jurisdiction issues defined therein. Any holder of this document is advised that information contained hereon reflects the Company's findings at the time of its intervention only and within the limits of Client's instructions, if any. The Company's sole responsibility is to its Client and this document does not exonerate parties to a transaction from exercising all their rights and obligations under the transaction documents. This document cannot be reproduced except in full, without prior written approval of the Company. Any unauthorized alteration, forgery or falsification of the content or appearance of this document is unlawful and offenders may be prosecuted to the fullest extent of the law.

Radiated Spurious Emission Measurement Result: LTE-Band 5 (The Worst Case)

Project Number	:T190304W06	Test Date	:2019-05-30
Operation Band	:LTE B5 5 QPSK 1.0	Temp./Humi.	:22.7/56.3
Fundamental Frequency	:826.5 MHz	Engineer	:Jerry
Operation Mode	:Tx CH Low	Measurement Antenna Pol.	:VERTICAL
EUT Pol.	:E2 Plan		

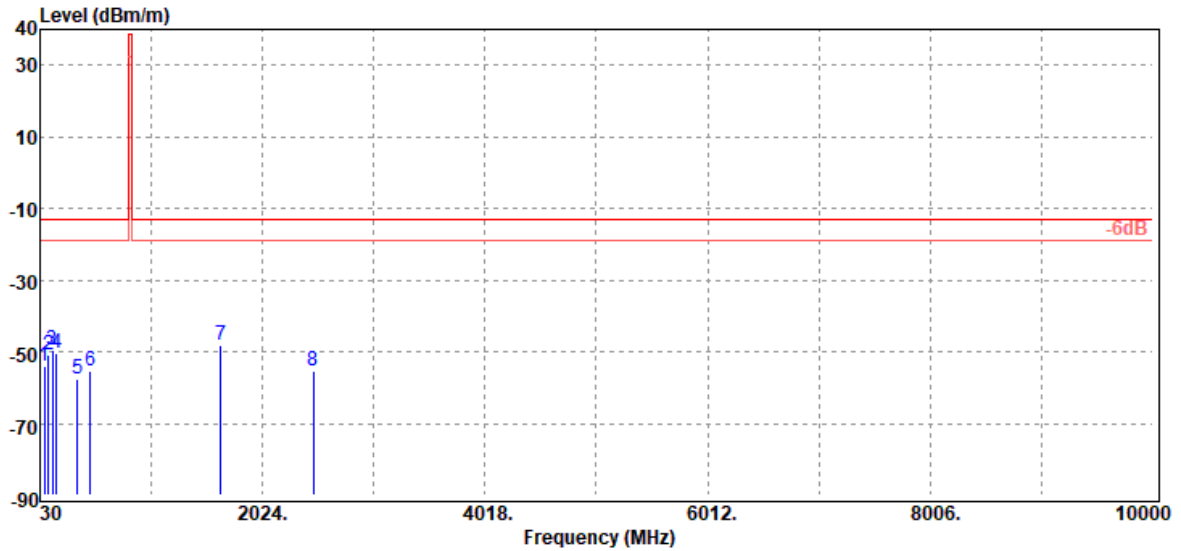

Freq. MHz	ERP/EIRP dBm	SG Output Level dBm	Antenna Gain dBd/dBi	Cable Loss dB	Limit dBm	Margin dB
70.74	-54.05	-43.76	-9.60	-0.69	-13.00	-41.05
104.69	-50.76	-40.68	-9.24	-0.84	-13.00	-37.76
144.46	-49.73	-40.93	-7.81	-0.99	-13.00	-36.73
180.35	-50.41	-44.95	-4.36	-1.10	-13.00	-37.41
366.59	-57.48	-54.1	-1.80	-1.58	-13.00	-44.48
482.99	-55.47	-51.3	-2.34	-1.83	-13.00	-42.47
1653.00	-48.16	-54.33	9.72	-3.55	-13.00	-35.16
2479.50	-55.45	-61.62	10.72	-4.55	-13.00	-42.45

Unless otherwise stated the results shown in this test report refer only to the sample(s) tested and such sample(s) are retained for 90 days only.

除非另有說明，此報告結果僅對測試之樣品負責，同時此樣品僅保留90天。本報告未經本公司書面許可，不可部份複製。

This document is issued by the Company subject to its General Conditions of Service printed overleaf, available on request or accessible at www.sgs.com/terms_and_conditions.htm and for electronic format documents, subject to Terms and Conditions for Electronic Documents at www.sgs.com/terms_e-document.htm. Attention is drawn to the limitation of liability, indemnification and jurisdiction issues defined therein. Any holder of this document is advised that information contained hereon reflects the Company's findings at the time of its intervention only and within the limits of Client's instructions, if any. The Company's sole responsibility is to its Client and this document does not exonerate parties to a transaction from exercising all their rights and obligations under the transaction documents. This document cannot be reproduced except in full, without prior written approval of the Company. Any unauthorized alteration, forgery or falsification of the content or appearance of this document is unlawful and offenders may be prosecuted to the fullest extent of the law.

Project Number :T190304W06
 Operation Band :LTE B5 5 QPSK 1.0
 Fundamental Frequency :826.5 MHz
 Operation Mode :Tx CH Low
 EUT Pol. :E2 Plan

Test Date :2019-05-30
 Temp./Humi. :22.7/56.3
 Engineer :Jerry
 Measurement Antenna Pol. :HORIZONTAL

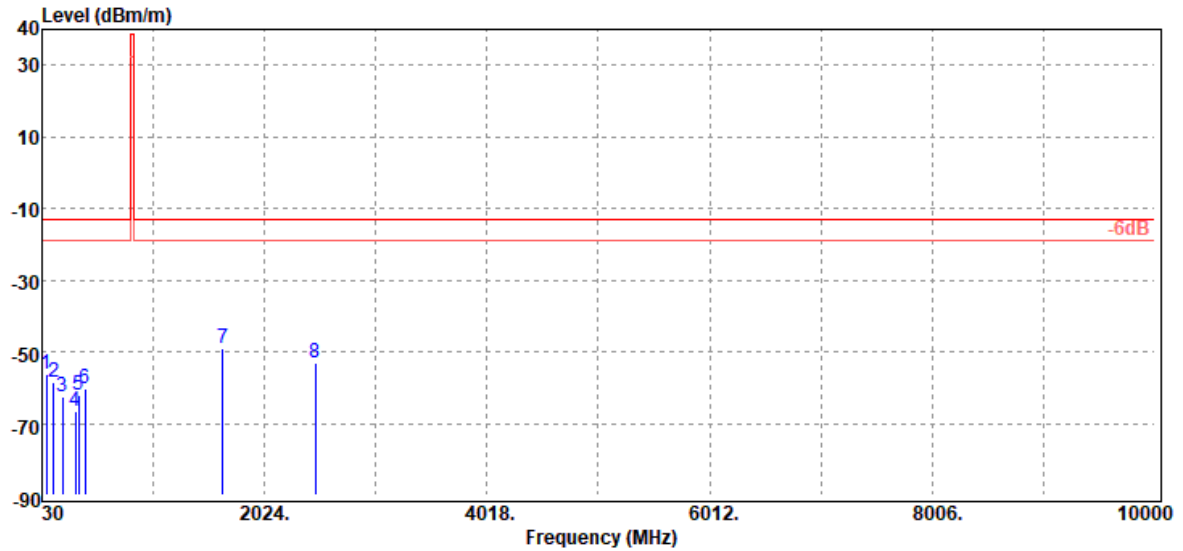

Freq. MHz	ERP/EIRP dBm	SG Output Level dBm	Antenna Gain dBd/dBi	Cable Loss dB	Limit dBm	Margin dB
70.74	-56.39	-46.1	-9.60	-0.69	-13.00	-43.39
136.70	-58.72	-48.7	-9.06	-0.96	-13.00	-45.72
212.36	-62.54	-59.24	-2.10	-1.20	-13.00	-49.54
330.70	-66.75	-63.56	-1.69	-1.50	-13.00	-53.75
356.89	-62.12	-59.01	-1.55	-1.56	-13.00	-49.12
416.06	-60.13	-56.54	-1.90	-1.69	-13.00	-47.13
1653.00	-48.99	-55.16	9.72	-3.55	-13.00	-35.99
2479.50	-53.18	-59.35	10.72	-4.55	-13.00	-40.18

Unless otherwise stated the results shown in this test report refer only to the sample(s) tested and such sample(s) are retained for 90 days only.

除非另有說明，此報告結果僅對測試之樣品負責，同時此樣品僅保留90天。本報告未經本公司書面許可，不可部份複製。

This document is issued by the Company subject to its General Conditions of Service printed overleaf, available on request or accessible at www.sgs.com/terms_and_conditions.htm and for electronic format documents, subject to Terms and Conditions for Electronic Documents at www.sgs.com/terms_e-document.htm. Attention is drawn to the limitation of liability, indemnification and jurisdiction issues defined therein. Any holder of this document is advised that information contained hereon reflects the Company's findings at the time of its intervention only and within the limits of Client's instructions, if any. The Company's sole responsibility is to its Client and this document does not exonerate parties to a transaction from exercising all their rights and obligations under the transaction documents. This document cannot be reproduced except in full, without prior written approval of the Company. Any unauthorized alteration, forgery or falsification of the content or appearance of this document is unlawful and offenders may be prosecuted to the fullest extent of the law.

Project Number :T190304W06
 Operation Band :LTE B5 5 QPSK 1.0
 Fundamental Frequency :836.5 MHz
 Operation Mode :Tx CH Mid
 EUT Pol. :E2 Plan

Test Date :2019-05-30
 Temp./Humi. :22.7/56.3
 Engineer :Jerry
 Measurement Antenna Pol. :VERTICAL

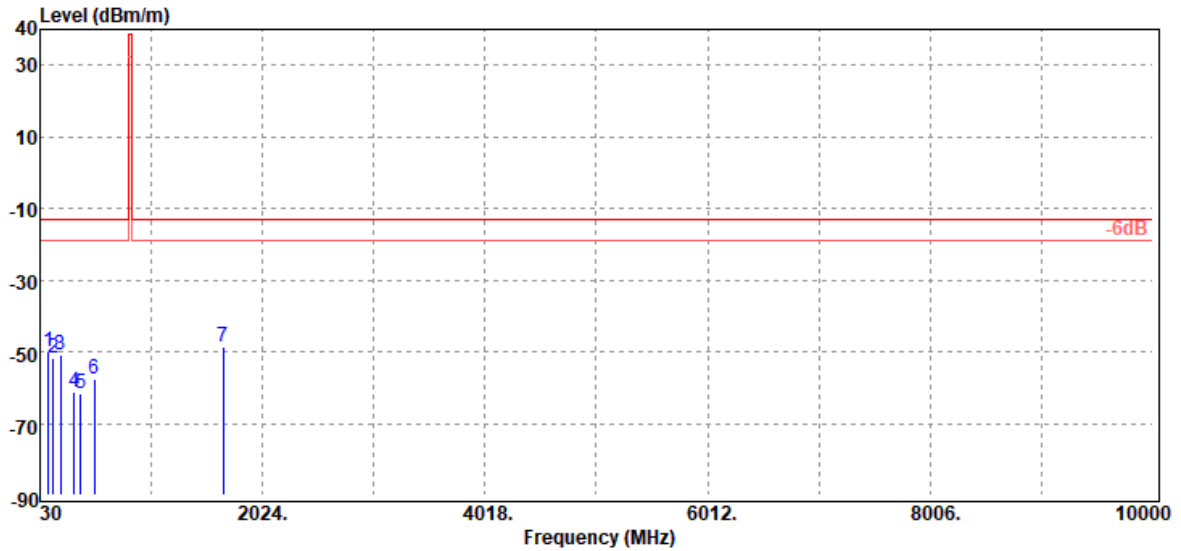

Freq. MHz	ERP/EIRP dBm	SG Output Level dBm	Antenna Gain dBd/dBi	Cable Loss dB	Limit dBm	Margin dB
105.66	-49.94	-39.73	-9.37	-0.84	-13.00	-36.94
146.40	-51.98	-43.45	-7.54	-0.99	-13.00	-38.98
211.39	-51.01	-47.72	-2.10	-1.19	-13.00	-38.01
333.61	-61.38	-58.24	-1.63	-1.51	-13.00	-48.38
390.84	-61.69	-58.62	-1.43	-1.64	-13.00	-48.69
517.91	-57.77	-54.43	-1.44	-1.90	-13.00	-44.77
1673.00	-48.80	-55.06	9.84	-3.58	-13.00	-35.80

Unless otherwise stated the results shown in this test report refer only to the sample(s) tested and such sample(s) are retained for 90 days only.

除非另有說明，此報告結果僅對測試之樣品負責，同時此樣品僅保留90天。本報告未經本公司書面許可，不可部份複製。

This document is issued by the Company subject to its General Conditions of Service printed overleaf, available on request or accessible at www.sgs.com/terms_and_conditions.htm and for electronic format documents, subject to Terms and Conditions for Electronic Documents at www.sgs.com/terms_e-document.htm. Attention is drawn to the limitation of liability, indemnification and jurisdiction issues defined therein. Any holder of this document is advised that information contained hereon reflects the Company's findings at the time of its intervention only and within the limits of Client's instructions, if any. The Company's sole responsibility is to its Client and this document does not exonerate parties to a transaction from exercising all their rights and obligations under the transaction documents. This document cannot be reproduced except in full, without prior written approval of the Company. Any unauthorized alteration, forgery or falsification of the content or appearance of this document is unlawful and offenders may be prosecuted to the fullest extent of the law.

Project Number :T190304W06
 Operation Band :LTE B5 5 QPSK 1.0
 Fundamental Frequency :836.5 MHz
 Operation Mode :Tx CH Mid
 EUT Pol. :E2 Plan

Test Date :2019-05-30
 Temp./Humi. :22.7/56.3
 Engineer :Jerry
 Measurement Antenna Pol. :HORIZONTAL

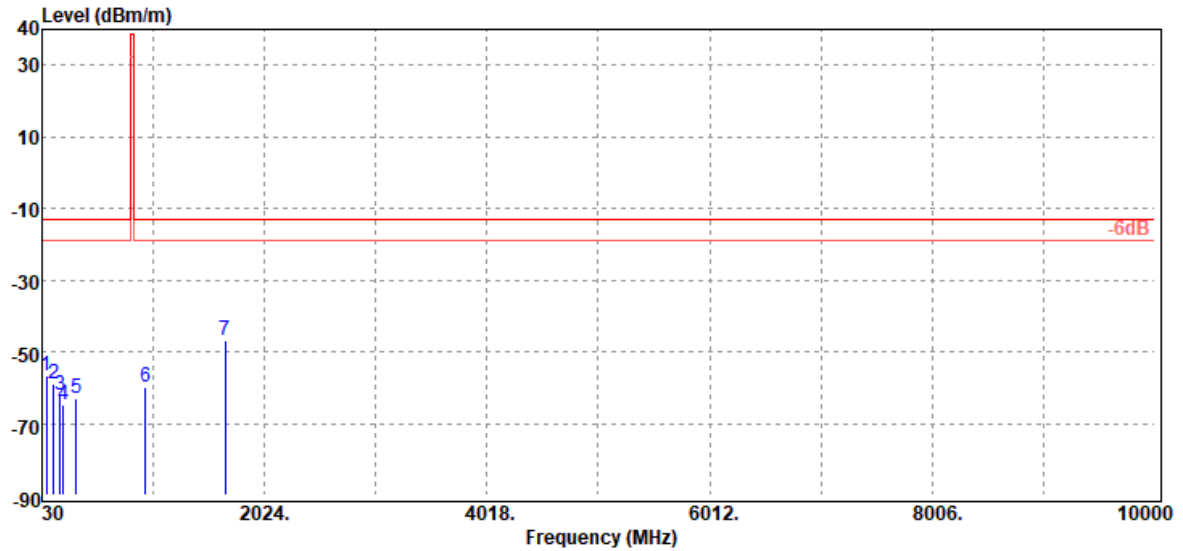

Freq. MHz	ERP/EIRP dBm	SG Output Level dBm	Antenna Gain dBd/dBi	Cable Loss dB	Limit dBm	Margin dB
70.74	-56.58	-46.29	-9.60	-0.69	-13.00	-43.58
136.70	-59.04	-49.02	-9.06	-0.96	-13.00	-46.04
190.05	-61.98	-56.85	-4.00	-1.13	-13.00	-48.98
224.00	-64.89	-61.74	-1.92	-1.23	-13.00	-51.89
335.55	-63.15	-60.05	-1.59	-1.51	-13.00	-50.15
956.35	-59.98	-56.13	-1.23	-2.62	-13.00	-46.98
1673.00	-46.95	-53.21	9.84	-3.58	-13.00	-33.95

Unless otherwise stated the results shown in this test report refer only to the sample(s) tested and such sample(s) are retained for 90 days only.

除非另有說明，此報告結果僅對測試之樣品負責，同時此樣品僅保留90天。本報告未經本公司書面許可，不可部份複製。

This document is issued by the Company subject to its General Conditions of Service printed overleaf, available on request or accessible at www.sgs.com/terms_and_conditions.htm and for electronic format documents, subject to Terms and Conditions for Electronic Documents at www.sgs.com/terms_e-document.htm. Attention is drawn to the limitation of liability, indemnification and jurisdiction issues defined therein. Any holder of this document is advised that information contained hereon reflects the Company's findings at the time of its intervention only and within the limits of Client's instructions, if any. The Company's sole responsibility is to its Client and this document does not exonerate parties to a transaction from exercising all their rights and obligations under the transaction documents. This document cannot be reproduced except in full, without prior written approval of the Company. Any unauthorized alteration, forgery or falsification of the content or appearance of this document is unlawful and offenders may be prosecuted to the fullest extent of the law.

Project Number :T190304W06
 Operation Band :LTE B5 5 QPSK 1.0
 Fundamental Frequency :846.5 MHz
 Operation Mode :Tx CH High
 EUT Pol. :E2 Plan

Test Date :2019-05-30
 Temp./Humi. :22.7/56.3
 Engineer :Jerry
 Measurement Antenna Pol. :VERTICAL

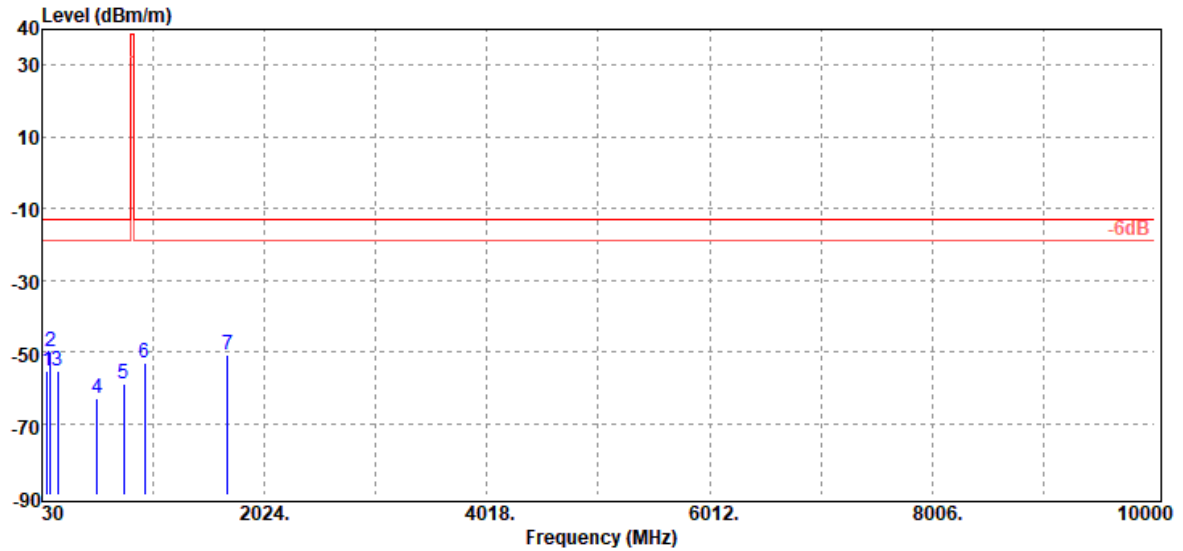

Freq. MHz	ERP/EIRP dBm	SG Output Level dBm	Antenna Gain dBd/dBi	Cable Loss dB	Limit dBm	Margin dB
75.59	-55.20	-45.51	-8.98	-0.71	-13.00	-42.20
104.69	-49.79	-39.71	-9.24	-0.84	-13.00	-36.79
170.65	-55.14	-48.74	-5.33	-1.07	-13.00	-42.14
521.79	-62.99	-59.72	-1.36	-1.91	-13.00	-49.99
760.41	-58.93	-55.21	-1.40	-2.32	-13.00	-45.93
951.50	-52.98	-49.16	-1.20	-2.62	-13.00	-39.98
1693.00	-50.96	-57.32	9.96	-3.60	-13.00	-37.96

Unless otherwise stated the results shown in this test report refer only to the sample(s) tested and such sample(s) are retained for 90 days only.

除非另有說明，此報告結果僅對測試之樣品負責，同時此樣品僅保留90天。本報告未經本公司書面許可，不可部份複製。

This document is issued by the Company subject to its General Conditions of Service printed overleaf, available on request or accessible at www.sgs.com/terms_and_conditions.htm and for electronic format documents, subject to Terms and Conditions for Electronic Documents at www.sgs.com/terms_e-document.htm. Attention is drawn to the limitation of liability, indemnification and jurisdiction issues defined therein. Any holder of this document is advised that information contained hereon reflects the Company's findings at the time of its intervention only and within the limits of Client's instructions, if any. The Company's sole responsibility is to its Client and this document does not exonerate parties to a transaction from exercising all their rights and obligations under the transaction documents. This document cannot be reproduced except in full, without prior written approval of the Company. Any unauthorized alteration, forgery or falsification of the content or appearance of this document is unlawful and offenders may be prosecuted to the fullest extent of the law.

Project Number :T190304W06
 Operation Band :LTE B5 5 QPSK 1.0
 Fundamental Frequency :846.5 MHz
 Operation Mode :Tx CH High
 EUT Pol. :E2 Plan

Test Date :2019-05-30
 Temp./Humi. :22.7/56.3
 Engineer :Jerry
 Measurement Antenna Pol. :HORIZONTAL

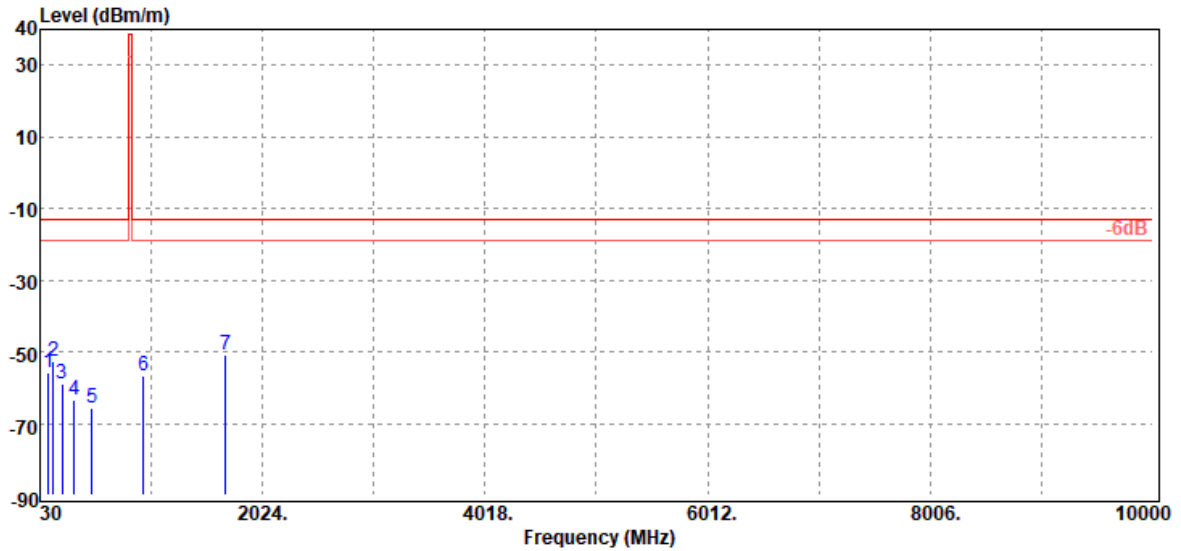

Freq. MHz	ERP/EIRP dBm	SG Output Level dBm	Antenna Gain dBd/dBi	Cable Loss dB	Limit dBm	Margin dB
104.69	-55.89	-45.81	-9.24	-0.84	-13.00	-42.89
151.25	-52.67	-44.61	-7.05	-1.01	-13.00	-39.67
226.91	-59.13	-55.91	-1.98	-1.24	-13.00	-46.13
338.46	-63.46	-60.41	-1.53	-1.52	-13.00	-50.46
493.66	-65.69	-61.79	-2.05	-1.85	-13.00	-52.69
958.29	-56.71	-52.82	-1.27	-2.62	-13.00	-43.71
1693.00	-50.67	-57.03	9.96	-3.60	-13.00	-37.67

Unless otherwise stated the results shown in this test report refer only to the sample(s) tested and such sample(s) are retained for 90 days only.

除非另有說明，此報告結果僅對測試之樣品負責，同時此樣品僅保留90天。本報告未經本公司書面許可，不可部份複製。

This document is issued by the Company subject to its General Conditions of Service printed overleaf, available on request or accessible at www.sgs.com/terms_and_conditions.htm and for electronic format documents, subject to Terms and Conditions for Electronic Documents at www.sgs.com/terms_e-document.htm. Attention is drawn to the limitation of liability, indemnification and jurisdiction issues defined therein. Any holder of this document is advised that information contained hereon reflects the Company's findings at the time of its intervention only and within the limits of Client's instructions, if any. The Company's sole responsibility is to its Client and this document does not exonerate parties to a transaction from exercising all their rights and obligations under the transaction documents. This document cannot be reproduced except in full, without prior written approval of the Company. Any unauthorized alteration, forgery or falsification of the content or appearance of this document is unlawful and offenders may be prosecuted to the fullest extent of the law.

Radiated Spurious Emission Measurement Result: LTE-Band 12 (The Worst Case)

Project Number	:T190304W06	Test Date	:2019-05-30
Operation Band	:LTE B12 10 QPSK 1.0	Temp./Humi.	:22.7/56.3
Fundamental Frequency	:704 MHz	Engineer	:Jerry
Operation Mode	:Tx CH Low	Measurement Antenna Pol.	:VERTICAL
EUT Pol.	:E2 Plan		

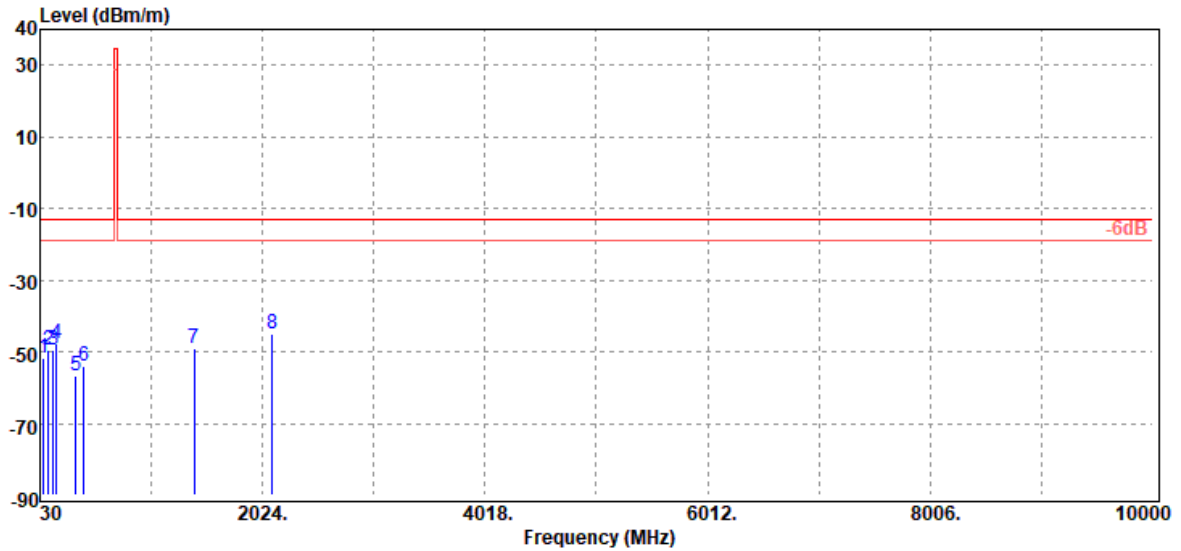

Freq. MHz	ERP/EIRP dBm	SG Output Level dBm	Antenna Gain dBd/dBi	Cable Loss dB	Limit dBm	Margin dB
65.89	-51.82	-41.31	-9.84	-0.67	-13.00	-38.82
104.69	-49.63	-39.55	-9.24	-0.84	-13.00	-36.63
151.25	-49.38	-41.32	-7.05	-1.01	-13.00	-36.38
180.35	-47.89	-42.43	-4.36	-1.10	-13.00	-34.89
348.16	-56.81	-53.77	-1.50	-1.54	-13.00	-43.81
419.94	-53.96	-50.36	-1.90	-1.70	-13.00	-40.96
1408.00	-48.94	-53.74	8.05	-3.25	-13.00	-35.94
2112.00	-44.99	-50.58	9.70	-4.11	-13.00	-31.99

Unless otherwise stated the results shown in this test report refer only to the sample(s) tested and such sample(s) are retained for 90 days only.

除非另有說明，此報告結果僅對測試之樣品負責，同時此樣品僅保留90天。本報告未經本公司書面許可，不可部份複製。

This document is issued by the Company subject to its General Conditions of Service printed overleaf, available on request or accessible at www.sgs.com/terms_and_conditions.htm and for electronic format documents, subject to Terms and Conditions for Electronic Documents at www.sgs.com/terms_e-document.htm. Attention is drawn to the limitation of liability, indemnification and jurisdiction issues defined therein. Any holder of this document is advised that information contained hereon reflects the Company's findings at the time of its intervention only and within the limits of Client's instructions, if any. The Company's sole responsibility is to its Client and this document does not exonerate parties to a transaction from exercising all their rights and obligations under the transaction documents. This document cannot be reproduced except in full, without prior written approval of the Company. Any unauthorized alteration, forgery or falsification of the content or appearance of this document is unlawful and offenders may be prosecuted to the fullest extent of the law.

Project Number :T190304W06
 Operation Band :LTE B12 10 QPSK 1.0
 Fundamental Frequency :704 MHz
 Operation Mode :Tx CH Low
 EUT Pol. :E2 Plan

Test Date :2019-05-30
 Temp./Humi. :22.7/56.3
 Engineer :Jerry
 Measurement Antenna Pol. :HORIZONTAL

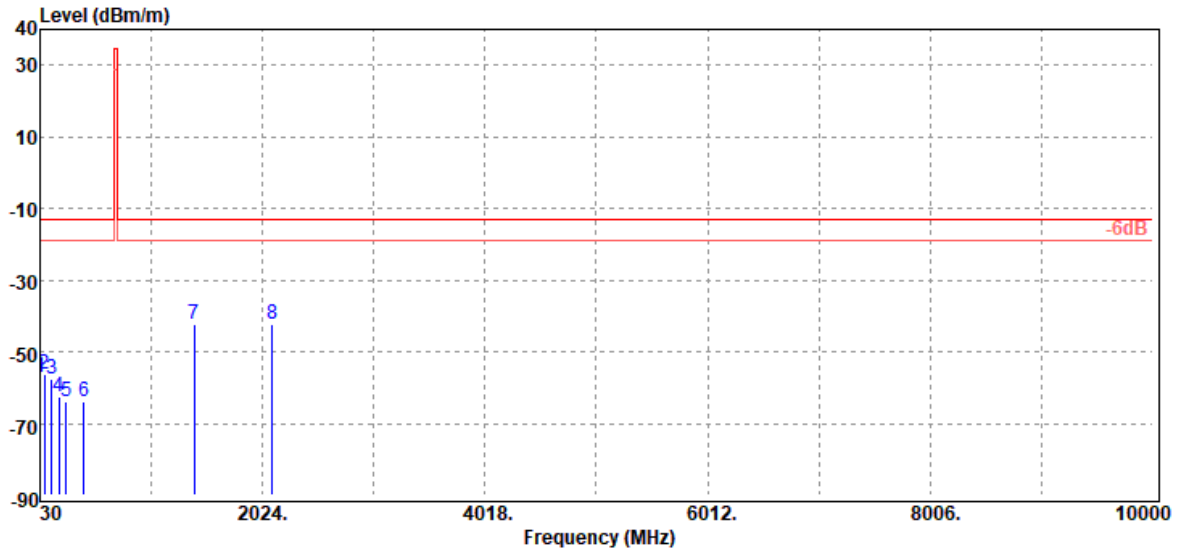

Freq. MHz	ERP/EIRP dBm	SG Output Level dBm	Antenna Gain dBd/dBi	Cable Loss dB	Limit dBm	Margin dB
30.00	-57.29	-26.74	-30.10	-0.45	-13.00	-44.29
70.74	-56.15	-45.86	-9.60	-0.69	-13.00	-43.15
136.70	-57.79	-47.77	-9.06	-0.96	-13.00	-44.79
202.66	-62.37	-57.46	-3.74	-1.17	-13.00	-49.37
262.80	-64.12	-60.64	-2.14	-1.34	-13.00	-51.12
422.85	-63.78	-60.18	-1.90	-1.70	-13.00	-50.78
1408.00	-42.51	-47.31	8.05	-3.25	-13.00	-29.51
2112.00	-42.12	-47.71	9.70	-4.11	-13.00	-29.12

Unless otherwise stated the results shown in this test report refer only to the sample(s) tested and such sample(s) are retained for 90 days only.

除非另有說明，此報告結果僅對測試之樣品負責，同時此樣品僅保留90天。本報告未經本公司書面許可，不可部份複製。

This document is issued by the Company subject to its General Conditions of Service printed overleaf, available on request or accessible at www.sgs.com/terms_and_conditions.htm and for electronic format documents, subject to Terms and Conditions for Electronic Documents at www.sgs.com/terms_e-document.htm. Attention is drawn to the limitation of liability, indemnification and jurisdiction issues defined therein. Any holder of this document is advised that information contained hereon reflects the Company's findings at the time of its intervention only and within the limits of Client's instructions, if any. The Company's sole responsibility is to its Client and this document does not exonerate parties to a transaction from exercising all their rights and obligations under the transaction documents. This document cannot be reproduced except in full, without prior written approval of the Company. Any unauthorized alteration, forgery or falsification of the content or appearance of this document is unlawful and offenders may be prosecuted to the fullest extent of the law.

Project Number :T190304W06
 Operation Band :LTE B12 10 QPSK 1.0
 Fundamental Frequency :707.5 MHz
 Operation Mode :Tx CH Mid
 EUT Pol. :E2 Plan

Test Date :2019-05-30
 Temp./Humi. :22.7/56.3
 Engineer :Jerry
 Measurement Antenna Pol. :VERTICAL

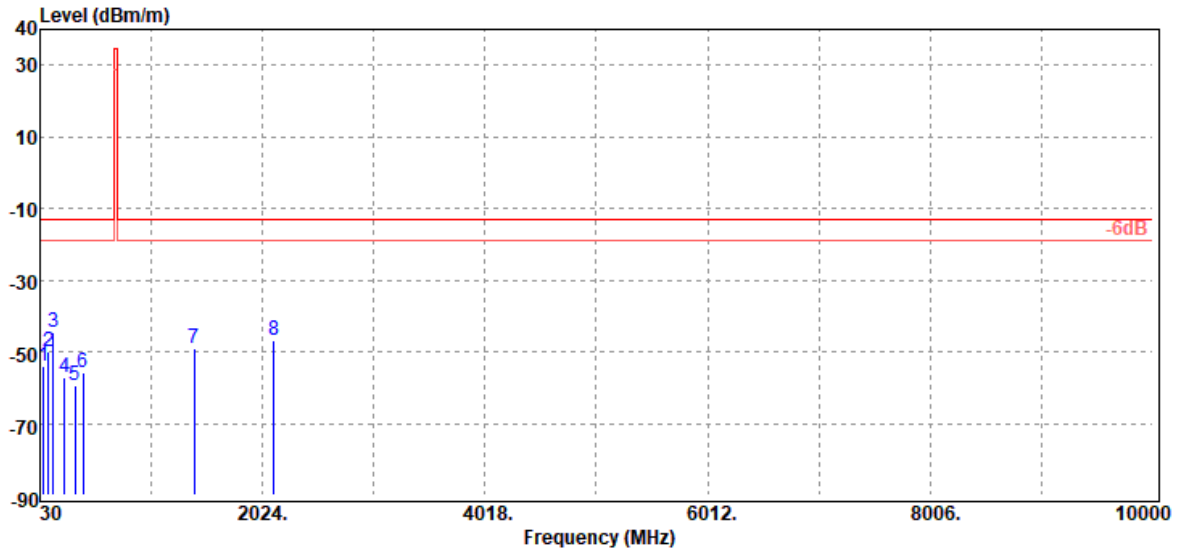

Freq. MHz	ERP/EIRP dBm	SG Output Level dBm	Antenna Gain dBd/dBi	Cable Loss dB	Limit dBm	Margin dB
65.89	-53.93	-43.42	-9.84	-0.67	-13.00	-40.93
104.69	-50.03	-39.95	-9.24	-0.84	-13.00	-37.03
148.34	-44.60	-36.33	-7.27	-1.00	-13.00	-31.60
248.25	-57.38	-54.25	-1.83	-1.30	-13.00	-44.38
342.34	-59.63	-56.6	-1.50	-1.53	-13.00	-46.63
415.09	-55.87	-52.28	-1.90	-1.69	-13.00	-42.87
1415.00	-49.07	-53.91	8.09	-3.25	-13.00	-36.07
2122.50	-46.88	-52.38	9.62	-4.12	-13.00	-33.88

Unless otherwise stated the results shown in this test report refer only to the sample(s) tested and such sample(s) are retained for 90 days only.

除非另有說明，此報告結果僅對測試之樣品負責，同時此樣品僅保留90天。本報告未經本公司書面許可，不可部份複製。

This document is issued by the Company subject to its General Conditions of Service printed overleaf, available on request or accessible at www.sgs.com/terms_and_conditions.htm and for electronic format documents, subject to Terms and Conditions for Electronic Documents at www.sgs.com/terms_e-document.htm. Attention is drawn to the limitation of liability, indemnification and jurisdiction issues defined therein. Any holder of this document is advised that information contained hereon reflects the Company's findings at the time of its intervention only and within the limits of Client's instructions, if any. The Company's sole responsibility is to its Client and this document does not exonerate parties to a transaction from exercising all their rights and obligations under the transaction documents. This document cannot be reproduced except in full, without prior written approval of the Company. Any unauthorized alteration, forgery or falsification of the content or appearance of this document is unlawful and offenders may be prosecuted to the fullest extent of the law.

Project Number :T190304W06
 Operation Band :LTE B12 10 QPSK 1.0
 Fundamental Frequency :707.5 MHz
 Operation Mode :Tx CH Mid
 EUT Pol. :E2 Plan

Test Date :2019-05-30
 Temp./Humi. :22.7/56.3
 Engineer :Jerry
 Measurement Antenna Pol. :HORIZONTAL

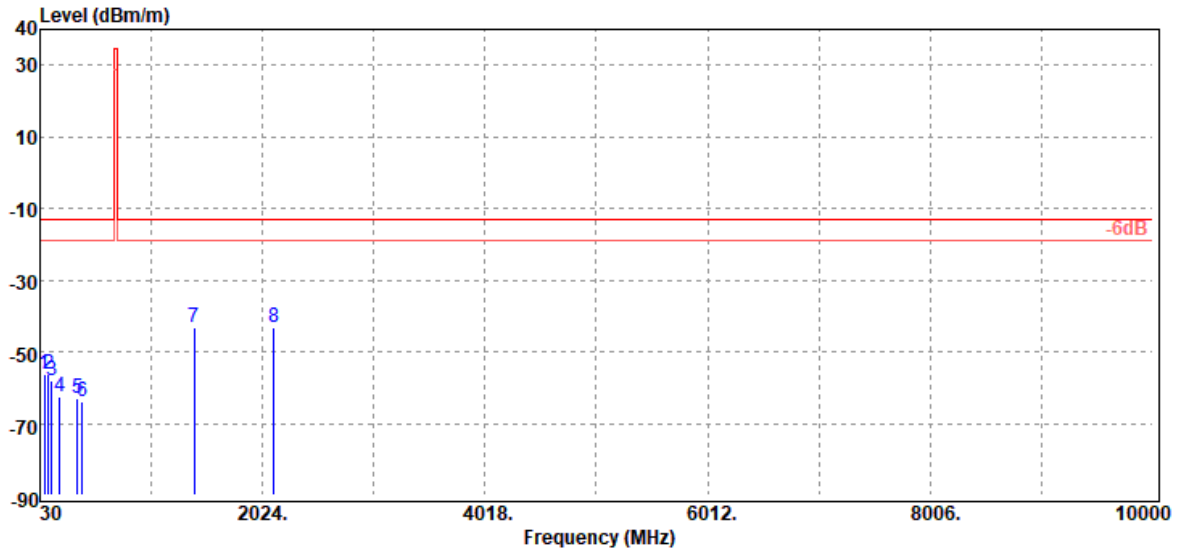

Freq. MHz	ERP/EIRP dBm	SG Output Level dBm	Antenna Gain dBd/dBi	Cable Loss dB	Limit dBm	Margin dB
70.74	-56.21	-45.92	-9.60	-0.69	-13.00	-43.21
104.69	-56.33	-46.25	-9.24	-0.84	-13.00	-43.33
136.70	-58.08	-48.06	-9.06	-0.96	-13.00	-45.08
205.57	-62.46	-58.56	-2.72	-1.18	-13.00	-49.46
362.71	-62.90	-59.52	-1.80	-1.58	-13.00	-49.90
405.39	-63.77	-60.3	-1.80	-1.67	-13.00	-50.77
1415.00	-43.00	-47.84	8.09	-3.25	-13.00	-30.00
2122.50	-43.33	-48.83	9.62	-4.12	-13.00	-30.33

Unless otherwise stated the results shown in this test report refer only to the sample(s) tested and such sample(s) are retained for 90 days only.

除非另有說明，此報告結果僅對測試之樣品負責，同時此樣品僅保留90天。本報告未經本公司書面許可，不可部份複製。

This document is issued by the Company subject to its General Conditions of Service printed overleaf, available on request or accessible at www.sgs.com/terms_and_conditions.htm and for electronic format documents, subject to Terms and Conditions for Electronic Documents at www.sgs.com/terms_e-document.htm. Attention is drawn to the limitation of liability, indemnification and jurisdiction issues defined therein. Any holder of this document is advised that information contained hereon reflects the Company's findings at the time of its intervention only and within the limits of Client's instructions, if any. The Company's sole responsibility is to its Client and this document does not exonerate parties to a transaction from exercising all their rights and obligations under the transaction documents. This document cannot be reproduced except in full, without prior written approval of the Company. Any unauthorized alteration, forgery or falsification of the content or appearance of this document is unlawful and offenders may be prosecuted to the fullest extent of the law.

Project Number :T190304W06
 Operation Band :LTE B12 10 QPSK 1.0
 Fundamental Frequency :711 MHz
 Operation Mode :Tx CH High
 EUT Pol. :E2 Plan

Test Date :2019-05-30
 Temp./Humi. :22.7/56.3
 Engineer :Jerry
 Measurement Antenna Pol. :VERTICAL

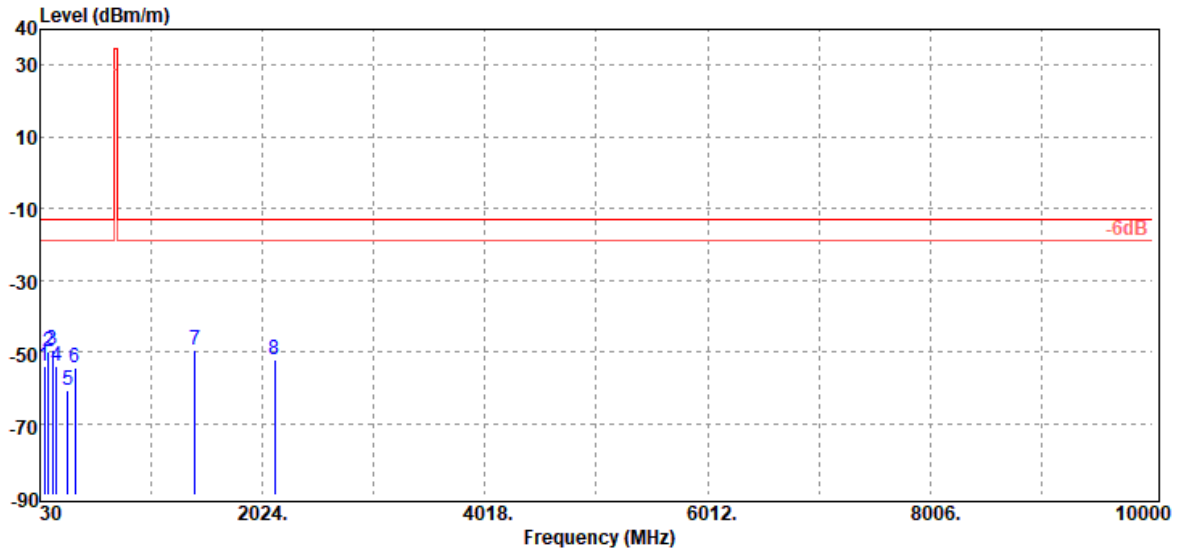

Freq. MHz	ERP/EIRP dBm	SG Output Level dBm	Antenna Gain dBd/dBi	Cable Loss dB	Limit dBm	Margin dB
70.74	-53.90	-43.61	-9.60	-0.69	-13.00	-40.90
104.69	-49.90	-39.82	-9.24	-0.84	-13.00	-36.90
144.46	-49.65	-40.85	-7.81	-0.99	-13.00	-36.65
178.41	-53.80	-48.14	-4.56	-1.10	-13.00	-40.80
279.29	-60.93	-56.95	-2.60	-1.38	-13.00	-47.93
340.40	-54.31	-51.28	-1.50	-1.53	-13.00	-41.31
1422.00	-49.68	-54.55	8.13	-3.26	-13.00	-36.68
2133.00	-52.36	-57.76	9.54	-4.14	-13.00	-39.36

Unless otherwise stated the results shown in this test report refer only to the sample(s) tested and such sample(s) are retained for 90 days only.

除非另有說明，此報告結果僅對測試之樣品負責，同時此樣品僅保留90天。本報告未經本公司書面許可，不可部份複製。

This document is issued by the Company subject to its General Conditions of Service printed overleaf, available on request or accessible at www.sgs.com/terms_and_conditions.htm and for electronic format documents, subject to Terms and Conditions for Electronic Documents at www.sgs.com/terms_e-document.htm. Attention is drawn to the limitation of liability, indemnification and jurisdiction issues defined therein. Any holder of this document is advised that information contained hereon reflects the Company's findings at the time of its intervention only and within the limits of Client's instructions, if any. The Company's sole responsibility is to its Client and this document does not exonerate parties to a transaction from exercising all their rights and obligations under the transaction documents. This document cannot be reproduced except in full, without prior written approval of the Company. Any unauthorized alteration, forgery or falsification of the content or appearance of this document is unlawful and offenders may be prosecuted to the fullest extent of the law.

Project Number :T190304W06
 Operation Band :LTE B12 10 QPSK 1.0
 Fundamental Frequency :711 MHz
 Operation Mode :Tx CH High
 EUT Pol. :E2 Plan

Test Date :2019-05-30
 Temp./Humi. :22.7/56.3
 Engineer :Jerry
 Measurement Antenna Pol. :HORIZONTAL

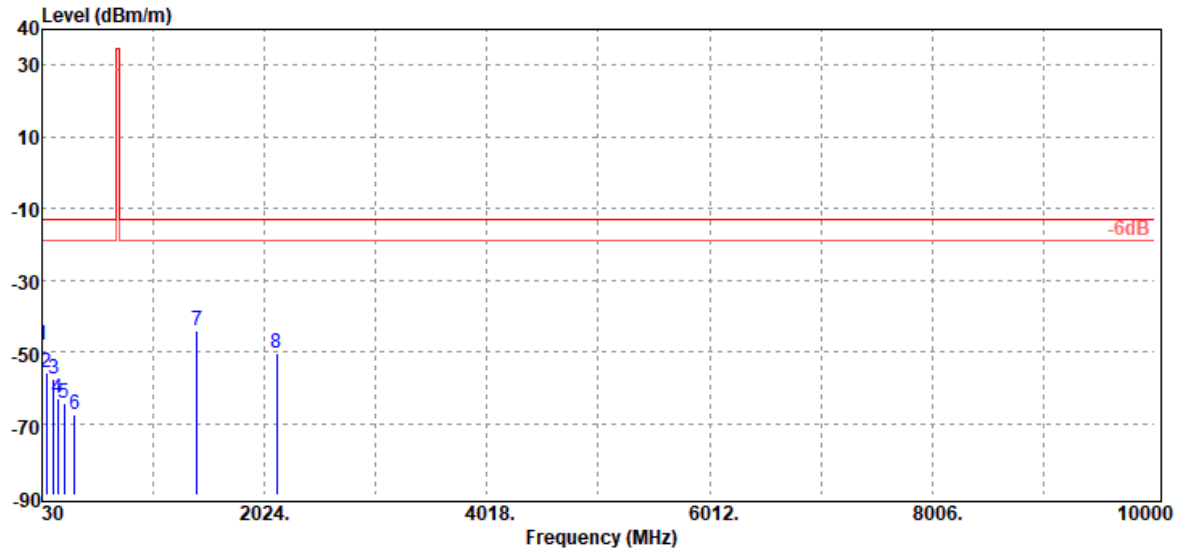

Freq. MHz	ERP/EIRP dBm	SG Output Level dBm	Antenna Gain dBd/dBi	Cable Loss dB	Limit dBm	Margin dB
30.00	-48.09	-17.54	-30.10	-0.45	-13.00	-35.09
70.74	-56.03	-45.74	-9.60	-0.69	-13.00	-43.03
136.70	-57.83	-47.81	-9.06	-0.96	-13.00	-44.83
173.56	-62.91	-56.84	-4.99	-1.08	-13.00	-49.91
226.91	-64.22	-61	-1.98	-1.24	-13.00	-51.22
323.91	-67.50	-64.21	-1.80	-1.49	-13.00	-54.50
1422.00	-43.91	-48.78	8.13	-3.26	-13.00	-30.91
2133.00	-50.46	-55.86	9.54	-4.14	-13.00	-37.46

Unless otherwise stated the results shown in this test report refer only to the sample(s) tested and such sample(s) are retained for 90 days only.

除非另有說明，此報告結果僅對測試之樣品負責，同時此樣品僅保留90天。本報告未經本公司書面許可，不可部份複製。

This document is issued by the Company subject to its General Conditions of Service printed overleaf, available on request or accessible at www.sgs.com/terms_and_conditions.htm and for electronic format documents, subject to Terms and Conditions for Electronic Documents at www.sgs.com/terms_e-document.htm. Attention is drawn to the limitation of liability, indemnification and jurisdiction issues defined therein. Any holder of this document is advised that information contained hereon reflects the Company's findings at the time of its intervention only and within the limits of Client's instructions, if any. The Company's sole responsibility is to its Client and this document does not exonerate parties to a transaction from exercising all their rights and obligations under the transaction documents. This document cannot be reproduced except in full, without prior written approval of the Company. Any unauthorized alteration, forgery or falsification of the content or appearance of this document is unlawful and offenders may be prosecuted to the fullest extent of the law.

10. FREQUENCY STABILITY MEASUREMENT

10.1. Standard Applicable

The frequency stability shall be sufficient to ensure that the fundamental emission stays within the authorized frequency block.

10.2. Test Set-up

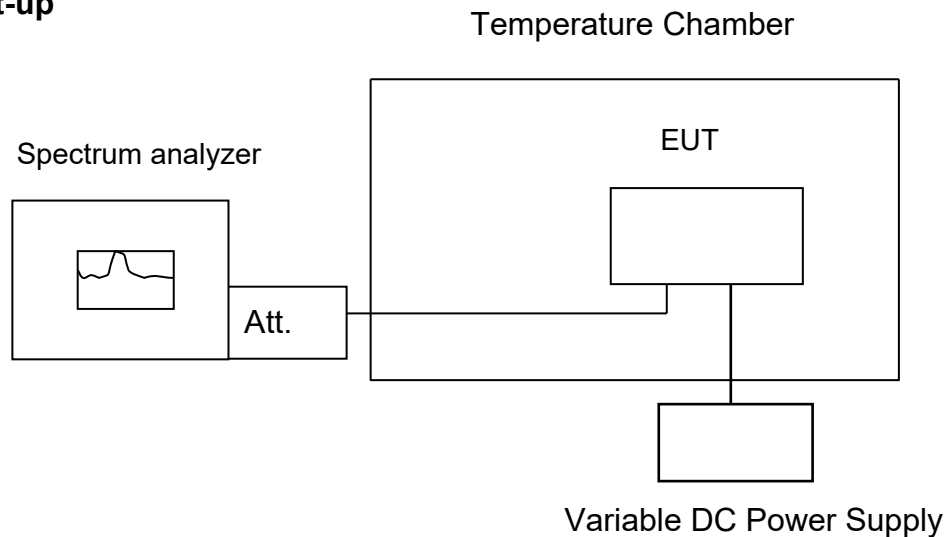

Note: Measurement setup for testing on Antenna connector

10.3. Measurement Procedure

The equipment under test was connected to an external AC or DC power supply and input rated voltage. RF output was connected to a frequency counter or spectrum analyzer via feed through attenuators. The EUT was placed inside the temperature chamber. Set the spectrum analyzer RBW low enough to obtain the desired frequency resolution and measure EUT 25°C operating frequency as reference frequency. Turn EUT off and set the chamber temperature to -30°C. After the temperature stabilized for approximately 30 minutes recorded the frequency. Repeat step measure with 10°C increased per stage until the highest temperature of +50°C reached.

Set chamber temperature to 25°C. Use a variable AC power supply / DC power source to power the EUT and set the voltage to rated voltage. Set the spectrum analyzer RBW low enough to obtain the desired frequency resolution and recorded the frequency.

Reduce the input voltage to specify extreme voltage variation (+/- 15%) and endpoint as declared by the manufacturer, record the maximum frequency change.

Unless otherwise stated the results shown in this test report refer only to the sample(s) tested and such sample(s) are retained for 90 days only.

除非另有說明，此報告結果僅對測試之樣品負責，同時此樣品僅保留90天。本報告未經本公司書面許可，不可部份複製。

This document is issued by the Company subject to its General Conditions of Service printed overleaf, available on request or accessible at www.sgs.com/terms_and_conditions.htm and for electronic format documents, subject to Terms and Conditions for Electronic Documents at www.sgs.com/terms_e-document.htm. Attention is drawn to the limitation of liability, indemnification and jurisdiction issues defined therein. Any holder of this document is advised that information contained hereon reflects the Company's findings at the time of its intervention only and within the limits of Client's instructions, if any. The Company's sole responsibility is to its Client and this document does not exonerate parties to a transaction from exercising all their rights and obligations under the transaction documents. This document cannot be reproduced except in full, without prior written approval of the Company. Any unauthorized alteration, forgery or falsification of the content or appearance of this document is unlawful and offenders may be prosecuted to the fullest extent of the law.

10.4. Measurement Equipment Used

EQUIPMENT TYPE	MFR	MODEL NUMBER	SERIAL NUMBER	LAST CAL.	CAL DUE.
EXA Spectrum Analyzer	Agilent	N9010A	MY57120290	02/13/2019	02/12/2020
Radio Communication Analyer	Anritsu	MT8820C	6201465317	01/16/2019	01/15/2020
DC Power Supply	Agilent	E3640A	MY52410006	12/04/2018	12/03/2019
Attenuator	Mini-Circuit	BW-S10W2+	2	01/02/2019	01/01/2020
DC Block	Mini-Circuits	BLK-18-S+	1	01/02/2019	01/01/2020
Splitter	RF-LAMBAD	RFLT2W1G18G	11-JSPF412-018	01/02/2019	01/01/2020
Coaxial Cables	N/A	WK CE Cable	N/A	01/02/2019	01/01/2020

Unless otherwise stated the results shown in this test report refer only to the sample(s) tested and such sample(s) are retained for 90 days only.

除非另有說明，此報告結果僅對測試之樣品負責，同時此樣品僅保留90天。本報告未經本公司書面許可，不可部份複製。

This document is issued by the Company subject to its General Conditions of Service printed overleaf, available on request or accessible at www.sgs.com/terms_and_conditions.htm and for electronic format documents, subject to Terms and Conditions for Electronic Documents at www.sgs.com/terms_e-document.htm. Attention is drawn to the limitation of liability, indemnification and jurisdiction issues defined therein. Any holder of this document is advised that information contained hereon reflects the Company's findings at the time of its intervention only and within the limits of Client's instructions, if any. The Company's sole responsibility is to its Client and this document does not exonerate parties to a transaction from exercising all their rights and obligations under the transaction documents. This document cannot be reproduced except in full, without prior written approval of the Company. Any unauthorized alteration, forgery or falsification of the content or appearance of this document is unlawful and offenders may be prosecuted to the fullest extent of the law.

10.5. Measurement Result

Reference Freq.:		LTE B2 Mid Channel		1880	MHz 20M QPSK CH 18900
Power Supply Vdc	Temp. (°C)	Freq. (MHz)	Delta (Hz)	Limit = +/- 2.5 ppm (Hz)	
Freq. ERROR vs. VOLTAGE					
4.1	25	1880.000004	4	4700	
3.6	25	1879.999996	-4	4700	
3	25	1879.999993	-7	4700	
2.9 (End Point)	25	1880.000002	2	4700	
Freq. ERROR vs. Temp.					
3.6	-30	1880.000000	0	4700	
3.6	-20	1880.000004	4	4700	
3.6	-10	1880.000009	9.0000001	4700	
3.6	0	1879.999996	-4	4700	
3.6	10	1879.999995	-5	4700	
3.6	20	1879.999998	-2	4700	
3.6	30	1879.999991	-9	4700	
3.6	40	1880.000007	7.0000001	4700	
3.6	50	1880.000004	4	4700	

Reference Freq.:		LTE B4 Mid Channel		1732.5	MHz 20M QPSK CH 20175
Power Supply Vdc	Temp. (°C)	Freq. (MHz)	Delta (Hz)	Limit = +/- 2.5 ppm (Hz)	
Freq. ERROR vs. VOLTAGE					
4.1	25	1732.500004	4	4331	
3.6	25	1732.499993	-7	4331	
3	25	1732.500008	8	4331	
2.9 (End Point)	25	1732.500001	1.0000001	4331	
Freq. ERROR vs. Temp.					
3.6	-30	1732.500003	3.0000001	4331	
3.6	-20	1732.500008	8	4331	
3.6	-10	1732.499994	-6	4331	
3.6	0	1732.499992	-8	4331	
3.6	10	1732.499995	-5	4331	
3.6	20	1732.500002	2	4331	
3.6	30	1732.499998	-2	4331	
3.6	40	1732.500002	2	4331	
3.6	50	1732.500002	2	4331	

Unless otherwise stated the results shown in this test report refer only to the sample(s) tested and such sample(s) are retained for 90 days only.

除非另有說明，此報告結果僅對測試之樣品負責，同時此樣品僅保留90天。本報告未經本公司書面許可，不可部份複製。

This document is issued by the Company subject to its General Conditions of Service printed overleaf, available on request or accessible at www.sgs.com/terms_and_conditions.htm and for electronic format documents, subject to Terms and Conditions for Electronic Documents at www.sgs.com/terms_e-document.htm. Attention is drawn to the limitation of liability, indemnification and jurisdiction issues defined therein. Any holder of this document is advised that information contained hereon reflects the Company's findings at the time of its intervention only and within the limits of Client's instructions, if any. The Company's sole responsibility is to its Client and this document does not exonerate parties to a transaction from exercising all their rights and obligations under the transaction documents. This document cannot be reproduced except in full, without prior written approval of the Company. Any unauthorized alteration, forgery or falsification of the content or appearance of this document is unlawful and offenders may be prosecuted to the fullest extent of the law.

Reference Freq.:		LTE B5 Mid Channel		836.5	MHz 10M QPSK CH 20525
Power Supply Vdc	Temp. (°C)	Freq. (MHz)	Delta (Hz)	Limit = +/- 2.5 ppm (Hz)	
Freq. ERROR vs. VOLTAGE					
4.1	25	836.499992	-8	2091	
3.6	25	836.500007	7	2091	
3	25	836.499998	-2	2091	
2.9 (End Point)	25	836.500003	3	2091	
Freq. ERROR vs. Temp.					
3.6	-30	836.499997	-3	2091	
3.6	-20	836.500001	1	2091	
3.6	-10	836.500007	7	2091	
3.6	0	836.499998	-2	2091	
3.6	10	836.499997	-3	2091	
3.6	20	836.500003	3	2091	
3.6	30	836.500000	0	2091	
3.6	40	836.499992	-8	2091	
3.6	50	836.500006	6	2091	

Reference Freq.:		LTE B12 Mid Channel		707.5	MHz 10M QPSK CH 23095
Power Supply Vdc	Temp. (°C)	Freq. (MHz)	Delta (Hz)	Limit = +/- 2.5 ppm (Hz)	
Freq. ERROR vs. VOLTAGE					
4.1	25	707.500004	4	1769	
3.6	25	707.500005	5	1769	
3	25	707.500004	4	1769	
2.9 (End Point)	25	707.500007	7	1769	
Freq. ERROR vs. Temp.					
3.6	-30	707.499999	-1	1769	
3.6	-20	707.500003	3	1769	
3.6	-10	707.500002	2	1769	
3.6	0	707.500007	7	1769	
3.6	10	707.500003	3	1769	
3.6	20	707.500003	3	1769	
3.6	30	707.500005	5	1769	
3.6	40	707.500002	2	1769	
3.6	50	707.500001	1	1769	

Note: The battery is rated 3.6Vdc.

Unless otherwise stated the results shown in this test report refer only to the sample(s) tested and such sample(s) are retained for 90 days only.

除非另有說明，此報告結果僅對測試之樣品負責，同時此樣品僅保留90天。本報告未經本公司書面許可，不可部份複製。

This document is issued by the Company subject to its General Conditions of Service printed overleaf, available on request or accessible at www.sgs.com/terms_and_conditions.htm and for electronic format documents, subject to Terms and Conditions for Electronic Documents at www.sgs.com/terms_e-document.htm. Attention is drawn to the limitation of liability, indemnification and jurisdiction issues defined therein. Any holder of this document is advised that information contained hereon reflects the Company's findings at the time of its intervention only and within the limits of Client's instructions, if any. The Company's sole responsibility is to its Client and this document does not exonerate parties to a transaction from exercising all their rights and obligations under the transaction documents. This document cannot be reproduced except in full, without prior written approval of the Company. Any unauthorized alteration, forgery or falsification of the content or appearance of this document is unlawful and offenders may be prosecuted to the fullest extent of the law.

11. PEAK TO AVERAGE RATIO

11.1. Standard Applicable

The peak-to-average ratio (PAR) of the transmission may not exceed 13dB.

11.2. Test SET-UP

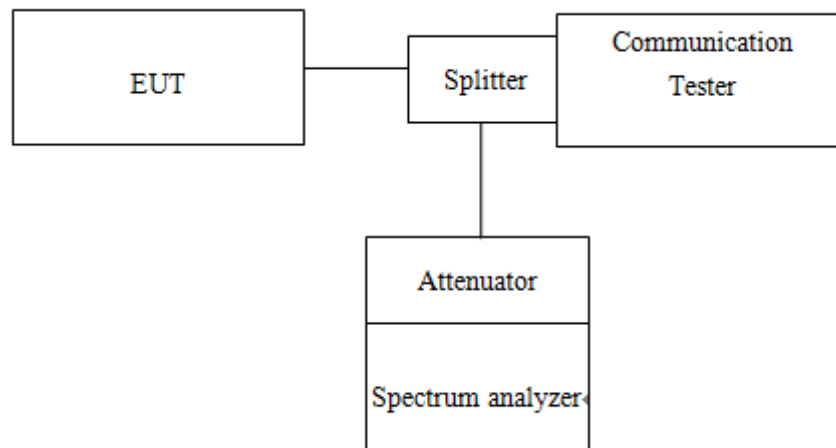

11.3. Measurement Procedure

1. KDB 971168 D01 is employed as the following procedure is proper adjusted accordingly:
2. Set resolution/measurement bandwidth \geq signal's occupied bandwidth; & internal =1ms
3. Set the number of counts to a value that stabilizes the measured CCDF curve.

11.4. Measurement Equipment Used

EQUIPMENT TYPE	MFR	MODEL NUMBER	SERIAL NUMBER	LAST CAL.	CAL DUE.
EXA Spectrum Analyzer	Agilent	N9010A	MY57120290	02/13/2019	02/12/2020
Radio Communication Analyer	Anritsu	MT8820C	6201465317	01/16/2019	01/15/2020
DC Power Supply	Agilent	E3640A	MY52410006	12/04/2018	12/03/2019
Attenuator	Mini-Circuit	BW-S10W2+	2	01/02/2019	01/01/2020
DC Block	Mini-Circuits	BLK-18-S+	1	01/02/2019	01/01/2020
Splitter	RF-LAMBAD	RFLT2W1G18G	11-JSPF412-018	01/02/2019	01/01/2020
Coaxial Cables	N/A	WK CE Cable	N/A	01/02/2019	01/01/2020

Unless otherwise stated the results shown in this test report refer only to the sample(s) tested and such sample(s) are retained for 90 days only.

除非另有說明，此報告結果僅對測試之樣品負責，同時此樣品僅保留90天。本報告未經本公司書面許可，不可部份複製。

This document is issued by the Company subject to its General Conditions of Service printed overleaf, available on request or accessible at www.sgs.com/terms_and_conditions.htm and for electronic format documents, subject to Terms and Conditions for Electronic Documents at www.sgs.com/terms_e-document.htm. Attention is drawn to the limitation of liability, indemnification and jurisdiction issues defined therein. Any holder of this document is advised that information contained hereon reflects the Company's findings at the time of its intervention only and within the limits of Client's instructions, if any. The Company's sole responsibility is to its Client and this document does not exonerate parties to a transaction from exercising all their rights and obligations under the transaction documents. This document cannot be reproduced except in full, without prior written approval of the Company. Any unauthorized alteration, forgery or falsification of the content or appearance of this document is unlawful and offenders may be prosecuted to the fullest extent of the law.

11.5. Measurement Result

Tabular Results:

LTE BAND 2							
Channel bandwidth: 1.4MHz				Channel bandwidth: 3MHz			
Freq. (MHz)	CH	PAPR (dB)		Freq. (MHz)	CH	PAPR (dB)	
		16QAM	Limit			16QAM	Limit
1850.7	18607	6.42	13	1851.5	18615	6.63	13
1880.0	18900	5.72	13	1880.0	18900	6.19	13
1909.3	19193	5.65	13	1908.5	19185	6.09	13

LTE BAND 2							
Channel bandwidth: 5MHz				Channel bandwidth: 10MHz			
Freq. (MHz)	CH	PAPR (dB)		Freq. (MHz)	CH	PAPR (dB)	
		16QAM	Limit			16QAM	Limit
1852.5	18625	6.53	13	1855.0	18650	6.31	13
1880.0	18900	5.93	13	1880.0	18900	6.10	13
1907.5	19175	5.83	13	1905.0	19150	5.99	13

LTE BAND 2							
Channel bandwidth: 15MHz				Channel bandwidth: 20MHz			
Freq. (MHz)	CH	PAPR (dB)		Freq. (MHz)	CH	PAPR (dB)	
		16QAM	Limit			16QAM	Limit
1857.5	18675	6.43	13	1860.0	18700	6.74	13
1880.0	18900	6.21	13	1880.0	18900	6.71	13
1902.5	19125	6.18	13	1900.0	19100	6.61	13

Unless otherwise stated the results shown in this test report refer only to the sample(s) tested and such sample(s) are retained for 90 days only.

除非另有說明，此報告結果僅對測試之樣品負責，同時此樣品僅保留90天。本報告未經本公司書面許可，不可部份複製。

This document is issued by the Company subject to its General Conditions of Service printed overleaf, available on request or accessible at www.sgs.com/terms_and_conditions.htm and for electronic format documents, subject to Terms and Conditions for Electronic Documents at www.sgs.com/terms_e-document.htm. Attention is drawn to the limitation of liability, indemnification and jurisdiction issues defined therein. Any holder of this document is advised that information contained hereon reflects the Company's findings at the time of its intervention only and within the limits of Client's instructions, if any. The Company's sole responsibility is to its Client and this document does not exonerate parties to a transaction from exercising all their rights and obligations under the transaction documents. This document cannot be reproduced except in full, without prior written approval of the Company. Any unauthorized alteration, forgery or falsification of the content or appearance of this document is unlawful and offenders may be prosecuted to the fullest extent of the law.

LTE BAND 4							
Channel bandwidth: 1.4MHz				Channel bandwidth: 3MHz			
Freq. (MHz)	CH	PAPR (dB)		Freq. (MHz)	CH	PAPR (dB)	
		16QAM	Limit			16QAM	Limit
1710.7	19957	6.55	13	1711.5	19965	6.47	13
1732.5	20175	6.82	13	1732.5	20175	6.62	13
1754.3	20393	6.15	13	1753.5	20385	6.23	13

LTE BAND 4							
Channel bandwidth: 5MHz				Channel bandwidth: 10MHz			
Freq. (MHz)	CH	PAPR (dB)		Freq. (MHz)	CH	PAPR (dB)	
		16QAM	Limit			16QAM	Limit
1712.5	19957	6.30	13	1715.0	20000	6.18	13
1732.5	20175	6.55	13	1732.5	20175	6.39	13
1752.5	20375	5.99	13	1750.0	20350	5.79	13

LTE BAND 4							
Channel bandwidth: 15MHz				Channel bandwidth: 20MHz			
Freq. (MHz)	CH	PAPR (dB)		Freq. (MHz)	CH	PAPR (dB)	
		16QAM	Limit			16QAM	Limit
1717.5	20025	6.20	13	1720.0	20050	6.69	13
1732.5	20175	6.28	13	1732.5	20175	6.75	13
1747.5	20325	6.03	13	1745.0	20300	6.69	13

LTE BAND 5							
Channel bandwidth: 1.4MHz				Channel bandwidth: 3MHz			
Freq. (MHz)	CH	PAPR (dB)		Freq. (MHz)	CH	PAPR (dB)	
		16QAM	Limit			16QAM	Limit
824.7	20407	6.30	13	825.5	20415	6.17	13
836.5	20525	5.11	13	836.5	20525	5.90	13
848.3	20643	6.40	13	847.5	20635	6.59	13

LTE BAND 5							
Channel bandwidth: 5MHz				Channel bandwidth: 10MHz			
Freq. (MHz)	CH	PAPR (dB)		Freq. (MHz)	CH	PAPR (dB)	
		16QAM	Limit			16QAM	Limit
826.5	20425	6.11	13	829.0	20450	5.79	13
836.5	20525	5.69	13	836.5	20525	5.81	13
846.5	20625	6.37	13	844.0	20600	6.56	13

Unless otherwise stated the results shown in this test report refer only to the sample(s) tested and such sample(s) are retained for 90 days only.

除非另有說明，此報告結果僅對測試之樣品負責，同時此樣品僅保留90天。本報告未經本公司書面許可，不可部份複製。

This document is issued by the Company subject to its General Conditions of Service printed overleaf, available on request or accessible at www.sgs.com/terms_and_conditions.htm and for electronic format documents, subject to Terms and Conditions for Electronic Documents at www.sgs.com/terms_e-document.htm. Attention is drawn to the limitation of liability, indemnification and jurisdiction issues defined therein. Any holder of this document is advised that information contained hereon reflects the Company's findings at the time of its intervention only and within the limits of Client's instructions, if any. The Company's sole responsibility is to its Client and this document does not exonerate parties to a transaction from exercising all their rights and obligations under the transaction documents. This document cannot be reproduced except in full, without prior written approval of the Company. Any unauthorized alteration, forgery or falsification of the content or appearance of this document is unlawful and offenders may be prosecuted to the fullest extent of the law.

LTE BAND 12							
Channel bandwidth: 1.4MHz				Channel bandwidth: 3MHz			
Freq. (MHz)	CH	PAPR (dB)		Freq. (MHz)	CH	PAPR (dB)	
		16QAM	Limit			16QAM	Limit
699.7	23017	6.42	13	700.5	23025	6.26	13
707.5	23095	6.59	13	707.5	23095	6.66	13
715.3	23173	6.65	13	714.5	23165	6.45	13

LTE BAND 12							
Channel bandwidth: 5MHz				Channel bandwidth: 10MHz			
Freq. (MHz)	CH	PAPR (dB)		Freq. (MHz)	CH	PAPR (dB)	
		16QAM	Limit			16QAM	Limit
701.5	23035	6.17	13	704.0	23060	6.16	13
707.5	23095	6.44	13	707.5	23095	6.30	13
713.5	23155	5.94	13	711.0	23130	6.21	13

Measurement Results:

Please refer to next page.

Unless otherwise stated the results shown in this test report refer only to the sample(s) tested and such sample(s) are retained for 90 days only.

除非另有說明，此報告結果僅對測試之樣品負責，同時此樣品僅保留90天。本報告未經本公司書面許可，不可部份複製。

This document is issued by the Company subject to its General Conditions of Service printed overleaf, available on request or accessible at www.sgs.com/terms_and_conditions.htm and for electronic format documents, subject to Terms and Conditions for Electronic Documents at www.sgs.com/terms_e-document.htm. Attention is drawn to the limitation of liability, indemnification and jurisdiction issues defined therein. Any holder of this document is advised that information contained hereon reflects the Company's findings at the time of its intervention only and within the limits of Client's instructions, if any. The Company's sole responsibility is to its Client and this document does not exonerate parties to a transaction from exercising all their rights and obligations under the transaction documents. This document cannot be reproduced except in full, without prior written approval of the Company. Any unauthorized alteration, forgery or falsification of the content or appearance of this document is unlawful and offenders may be prosecuted to the fullest extent of the law.

LTE_Band2_1_4MHz_16QAM_6_0_LowCH18607-1850.7

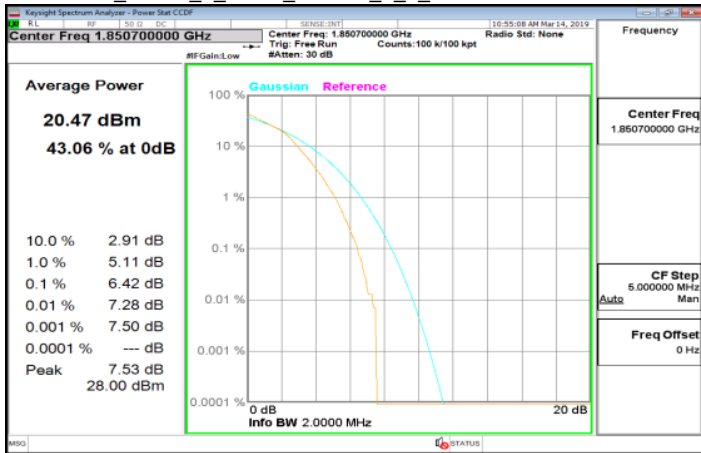

LTE_Band2_3MHz_16QAM_15_0_LowCH18615-1851.5

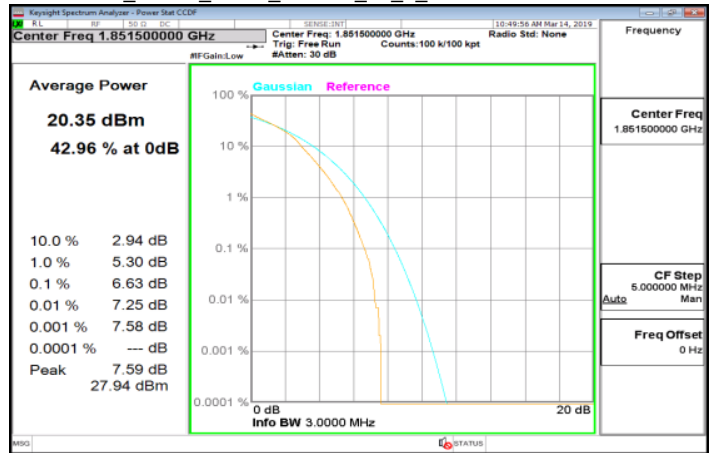

LTE_Band2_1_4MHz_16QAM_6_0_MidCH18900-1880

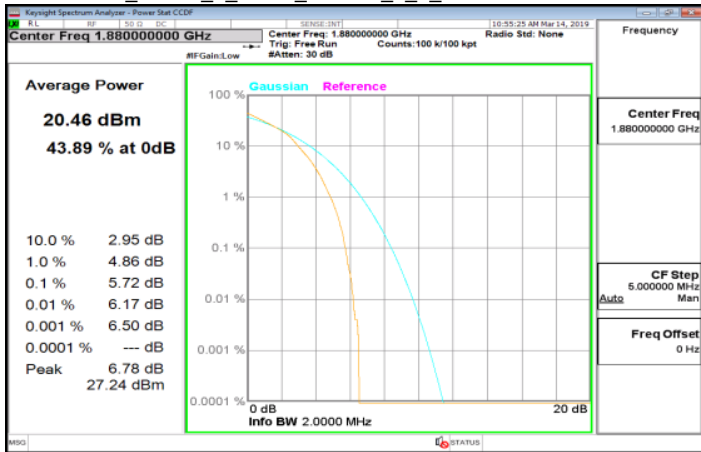

LTE_Band2_3MHz_16QAM_15_0_MidCH18900-1880

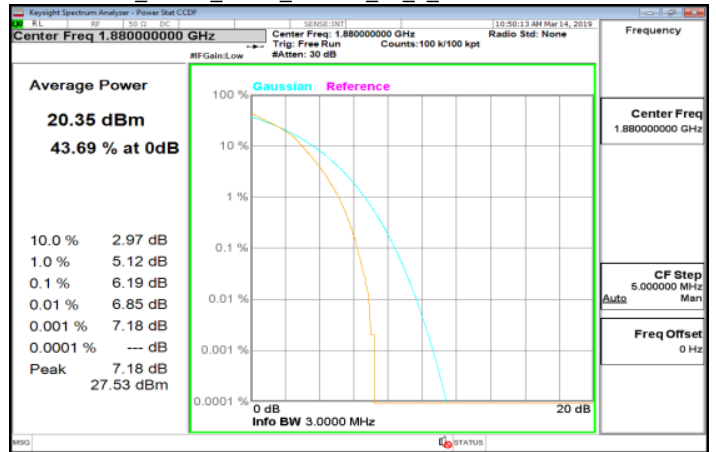

LTE_Band2_1_4MHz_16QAM_6_0_HighCH19193-1909.3

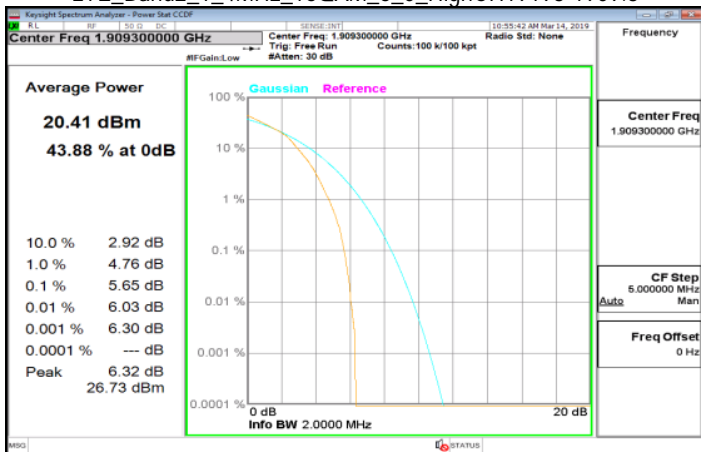

LTE_Band2_3MHz_16QAM_15_0_HighCH19185-1908.5

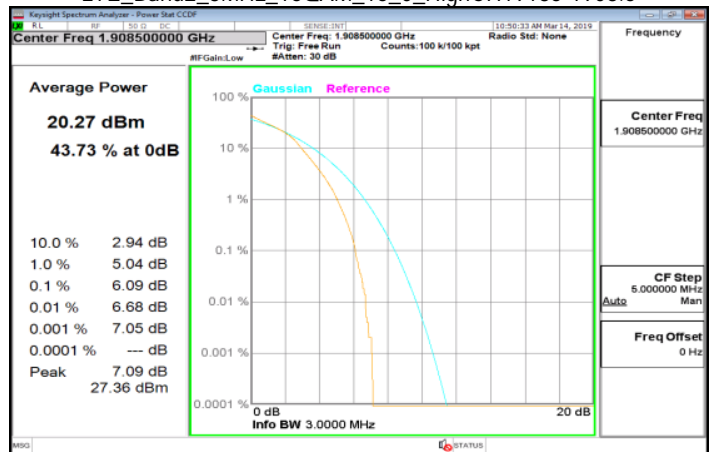

Unless otherwise stated the results shown in this test report refer only to the sample(s) tested and such sample(s) are retained for 90 days only.

除非另有說明，此報告結果僅對測試之樣品負責，同時此樣品僅保留90天。本報告未經本公司書面許可，不可部份複製。

This document is issued by the Company subject to its General Conditions of Service printed overleaf, available on request or accessible at www.sgs.com/terms_and_conditions.htm and for electronic format documents, subject to Terms and Conditions for Electronic Documents at www.sgs.com/terms_e-document.htm. Attention is drawn to the limitation of liability, indemnification and jurisdiction issues defined therein. Any holder of this document is advised that information contained hereon reflects the Company's findings at the time of its intervention only and within the limits of Client's instructions, if any. The Company's sole responsibility is to its Client and this document does not exonerate parties to a transaction from exercising all their rights and obligations under the transaction documents. This document cannot be reproduced except in full, without prior written approval of the Company. Any unauthorized alteration, forgery or falsification of the content or appearance of this document is unlawful and offenders may be prosecuted to the fullest extent of the law.

LTE_Band2_5MHz_16QAM_25_0_LowCH18625-1852.5

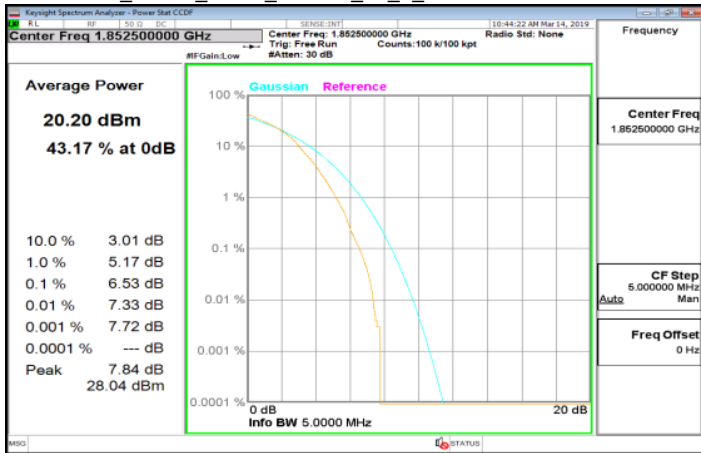

LTE_Band2_10MHz_16QAM_50_0_LowCH18650-1855

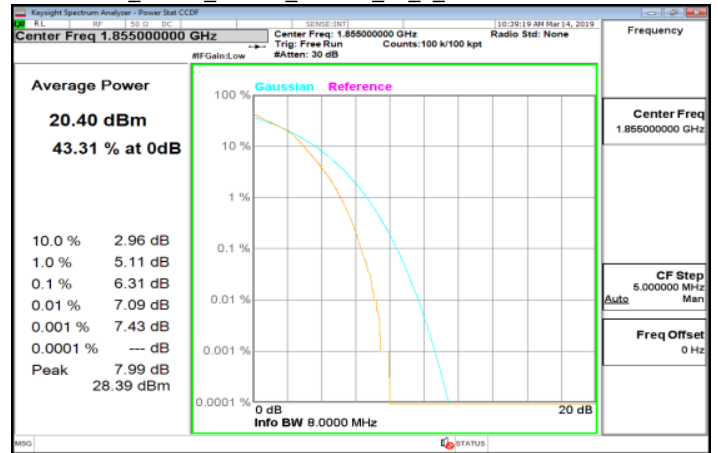

LTE_Band2_5MHz_16QAM_25_0_MidCH18900-1880

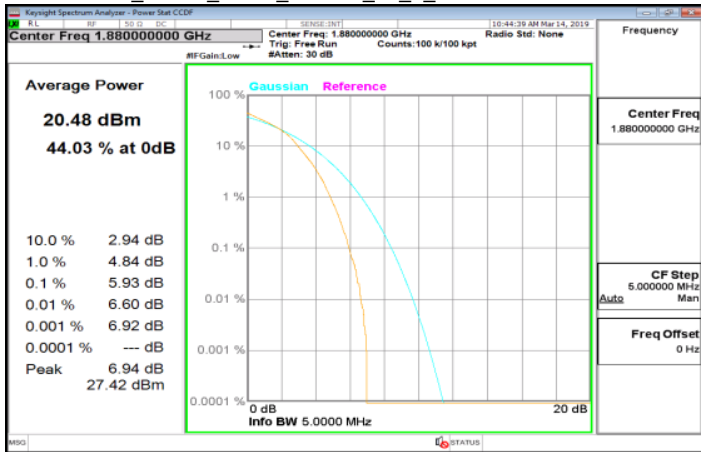

LTE_Band2_10MHz_16QAM_50_0_MidCH18900-1880

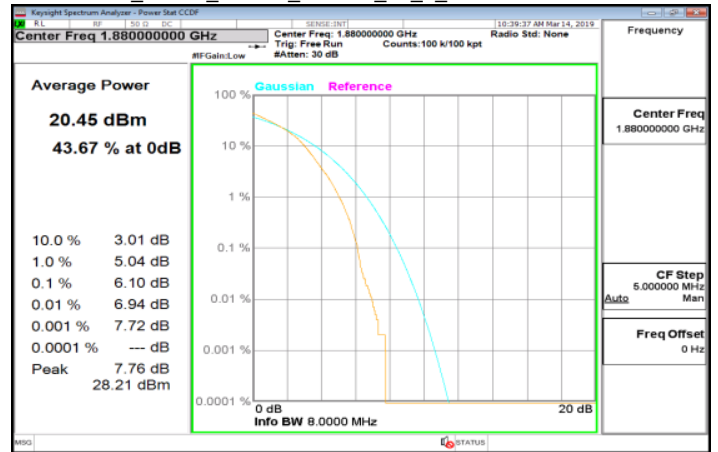

LTE_Band2_5MHz_16QAM_25_0_HighCH19175-1907.5

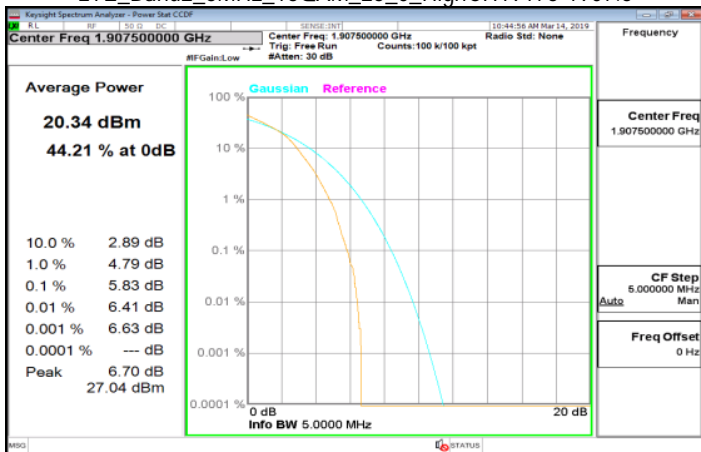

LTE_Band2_10MHz_16QAM_50_0_HighCH19150-1905

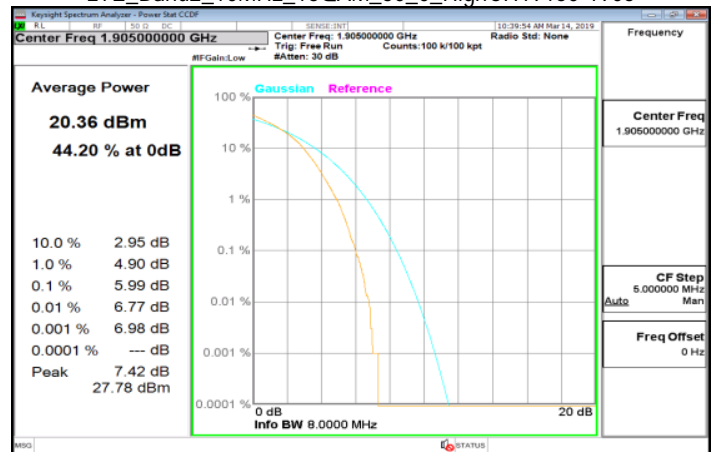

Unless otherwise stated the results shown in this test report refer only to the sample(s) tested and such sample(s) are retained for 90 days only.

除非另有說明，此報告結果僅對測試之樣品負責，同時此樣品僅保留90天。本報告未經本公司書面許可，不可部份複製。

This document is issued by the Company subject to its General Conditions of Service printed overleaf, available on request or accessible at www.sgs.com/terms_and_conditions.htm and for electronic format documents, subject to Terms and Conditions for Electronic Documents at www.sgs.com/terms_e-document.htm. Attention is drawn to the limitation of liability, indemnification and jurisdiction issues defined therein. Any holder of this document is advised that information contained hereon reflects the Company's findings at the time of its intervention only and within the limits of Client's instructions, if any. The Company's sole responsibility is to its Client and this document does not exonerate parties to a transaction from exercising all their rights and obligations under the transaction documents. This document cannot be reproduced except in full, without prior written approval of the Company. Any unauthorized alteration, forgery or falsification of the content or appearance of this document is unlawful and offenders may be prosecuted to the fullest extent of the law.

LTE_Band2_15MHz_16QAM_75_0_LowCH18675-1857.5

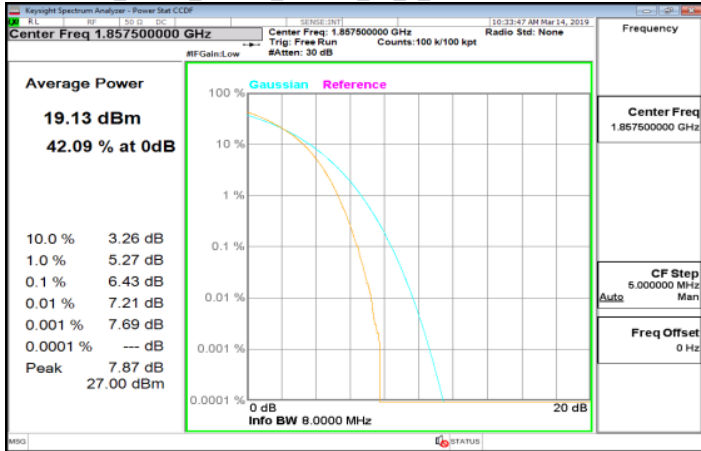

LTE_Band2_20MHz_16QAM_100_0_LowCH18700-1860

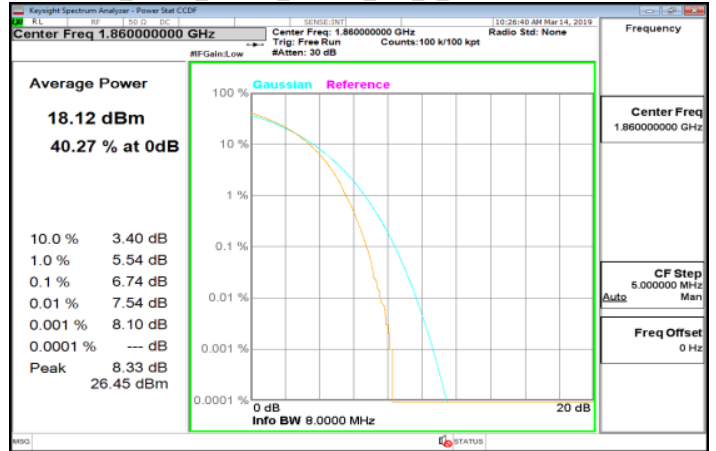

LTE_Band2_15MHz_16QAM_75_0_MidCH18900-1880

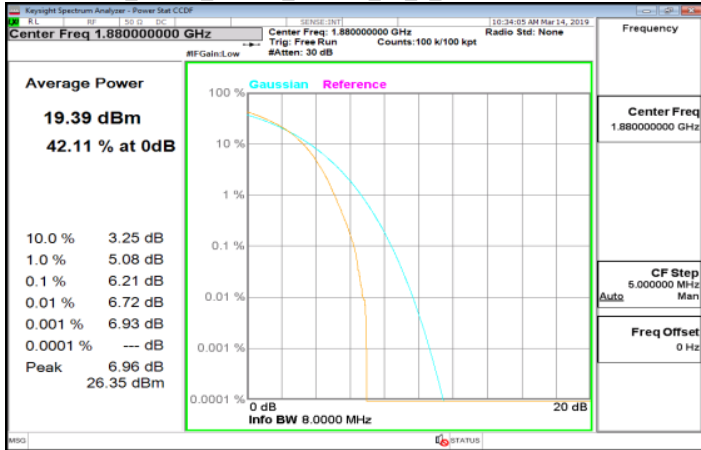

LTE_Band2_20MHz_16QAM_100_0_MidCH18900-1880

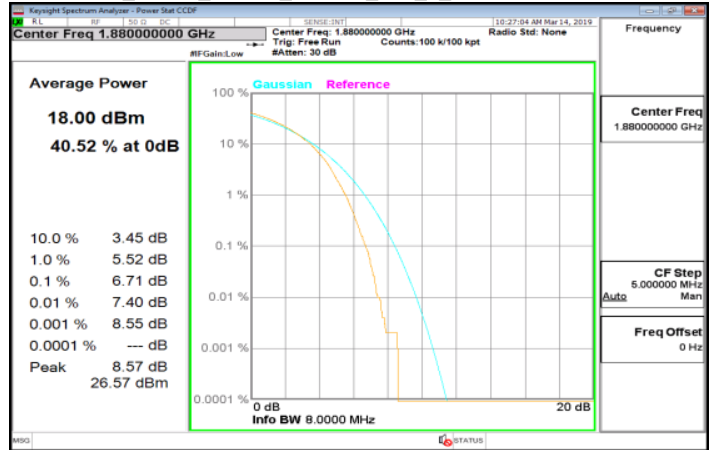

LTE_Band2_15MHz_16QAM_75_0_HighCH19125-1902.5

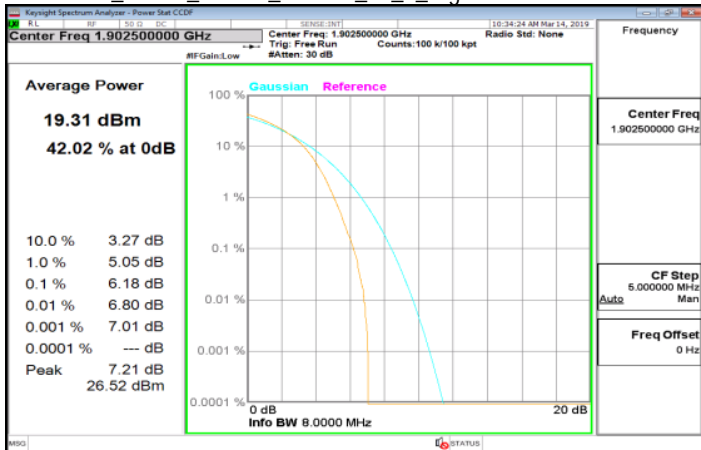

LTE_Band2_20MHz_16QAM_100_0_HighCH19100-1900

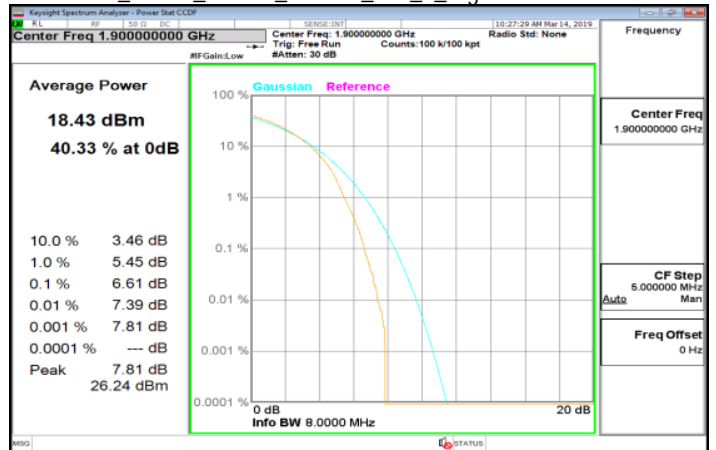

Unless otherwise stated the results shown in this test report refer only to the sample(s) tested and such sample(s) are retained for 90 days only.

除非另有說明，此報告結果僅對測試之樣品負責，同時此樣品僅保留90天。本報告未經本公司書面許可，不可部份複製。

This document is issued by the Company subject to its General Conditions of Service printed overleaf, available on request or accessible at www.sgs.com/terms_and_conditions.htm and for electronic format documents, subject to Terms and Conditions for Electronic Documents at www.sgs.com/terms_e-document.htm. Attention is drawn to the limitation of liability, indemnification and jurisdiction issues defined therein. Any holder of this document is advised that information contained hereon reflects the Company's findings at the time of its intervention only and within the limits of Client's instructions, if any. The Company's sole responsibility is to its Client and this document does not exonerate parties to a transaction from exercising all their rights and obligations under the transaction documents. This document cannot be reproduced except in full, without prior written approval of the Company. Any unauthorized alteration, forgery or falsification of the content or appearance of this document is unlawful and offenders may be prosecuted to the fullest extent of the law.

LTE_Band4_1_4MHz_16QAM_6_0_LowCH19957-1710.7

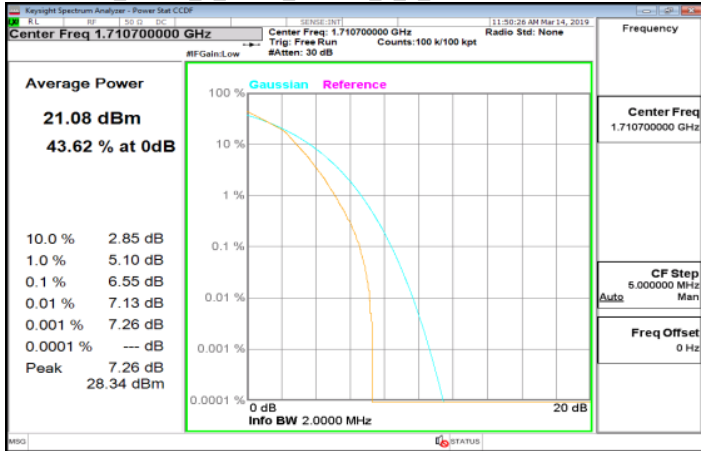

LTE_Band4_3MHz_16QAM_15_0_LowCH19965-1711.5

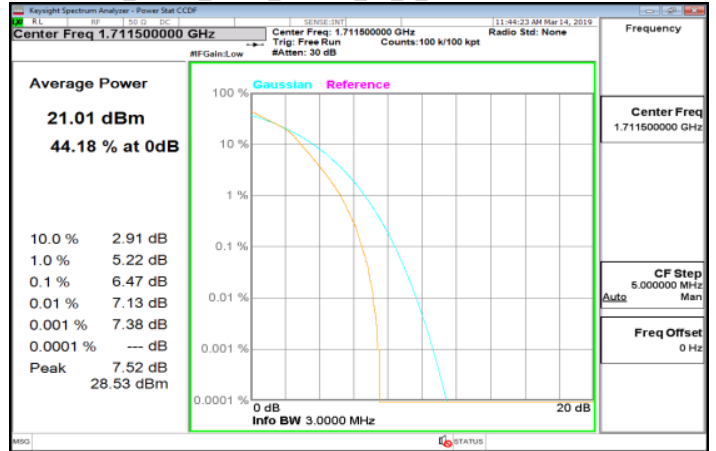

LTE_Band4_1_4MHz_16QAM_6_0_MidCH20175-1732.5

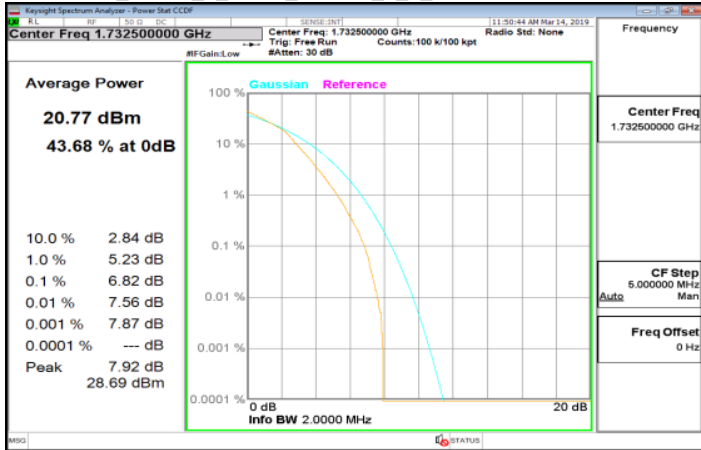

LTE_Band4_3MHz_16QAM_15_0_MidCH20175-1732.5

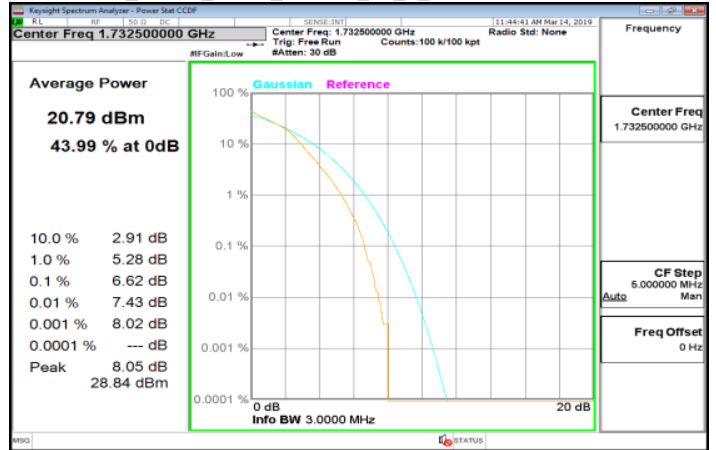

LTE_Band4_1_4MHz_16QAM_6_0_HighCH20393-1754.3

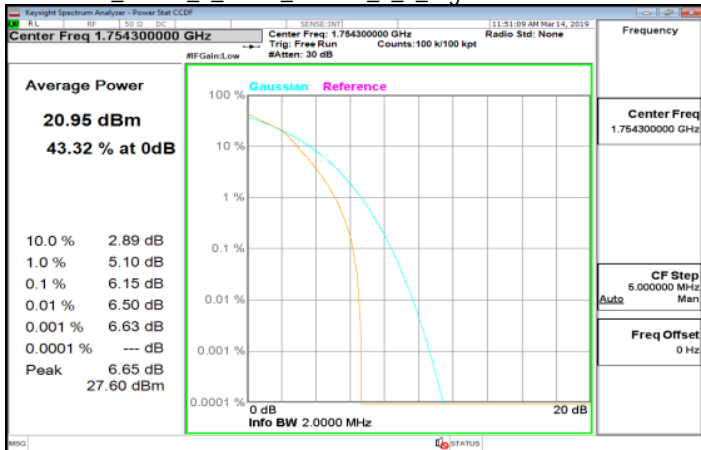

LTE_Band4_3MHz_16QAM_15_0_HighCH20385-1753.5

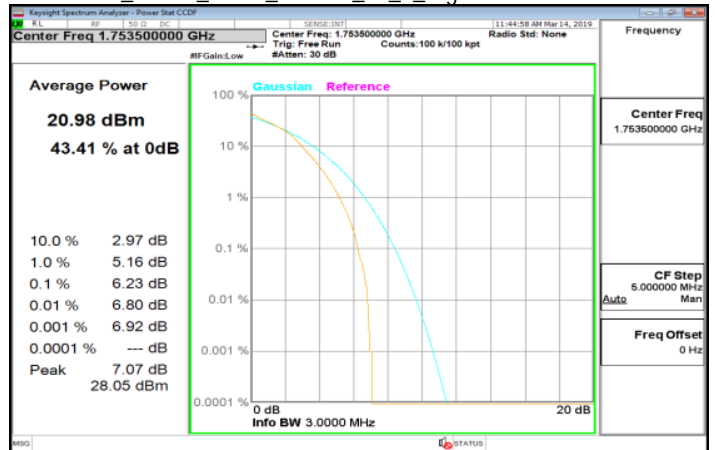

Unless otherwise stated the results shown in this test report refer only to the sample(s) tested and such sample(s) are retained for 90 days only.

除非另有說明，此報告結果僅對測試之樣品負責，同時此樣品僅保留90天。本報告未經本公司書面許可，不可部份複製。

This document is issued by the Company subject to its General Conditions of Service printed overleaf, available on request or accessible at www.sgs.com/terms_and_conditions.htm and for electronic format documents, subject to Terms and Conditions for Electronic Documents at www.sgs.com/terms_e-document.htm. Attention is drawn to the limitation of liability, indemnification and jurisdiction issues defined therein. Any holder of this document is advised that information contained hereon reflects the Company's findings at the time of its intervention only and within the limits of Client's instructions, if any. The Company's sole responsibility is to its Client and this document does not exonerate parties to a transaction from exercising all their rights and obligations under the transaction documents. This document cannot be reproduced except in full, without prior written approval of the Company. Any unauthorized alteration, forgery or falsification of the content or appearance of this document is unlawful and offenders may be prosecuted to the fullest extent of the law.

LTE_Band4_5MHz_16QAM_25_0_LowCH19975-1712.5

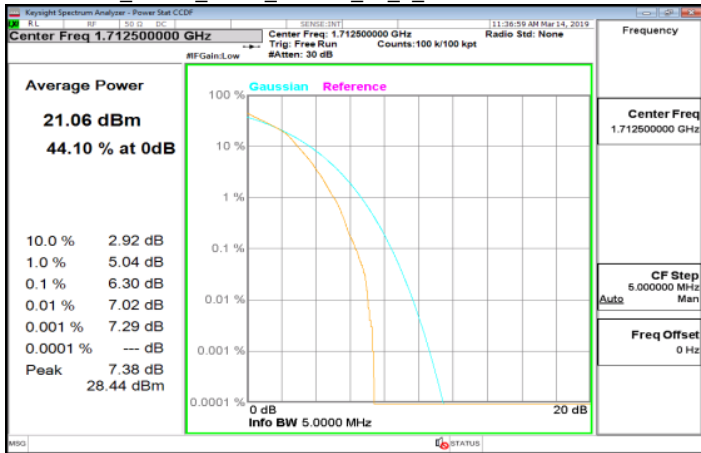

LTE_Band4_10MHz_16QAM_50_0_LowCH20000-1715

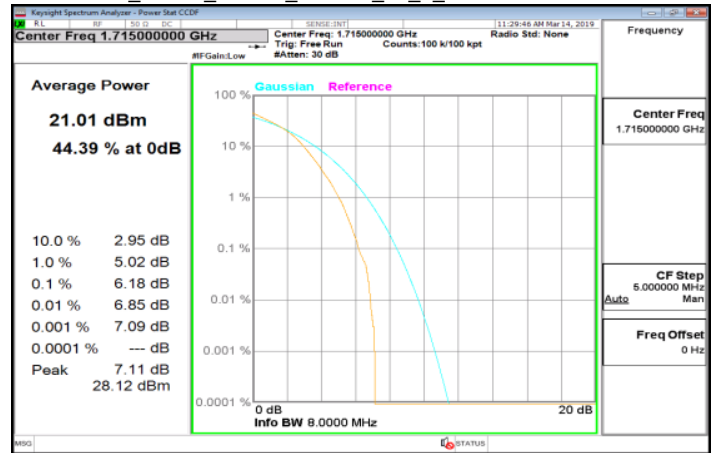

LTE_Band4_5MHz_16QAM_25_0_MidCH20175-1732.5

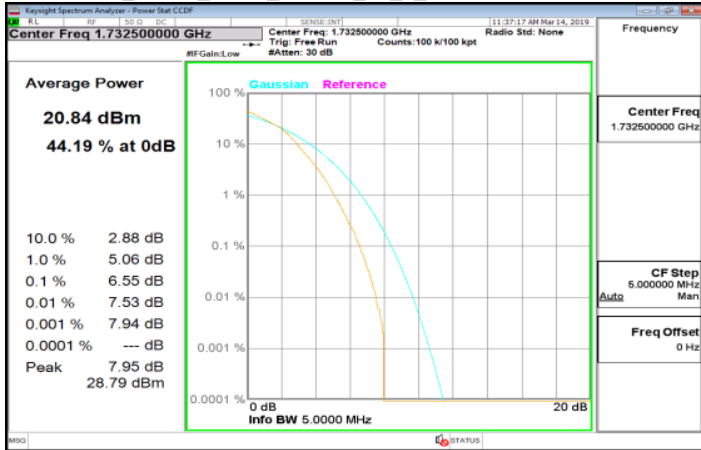

LTE_Band4_10MHz_16QAM_50_0_MidCH20175-1732.5

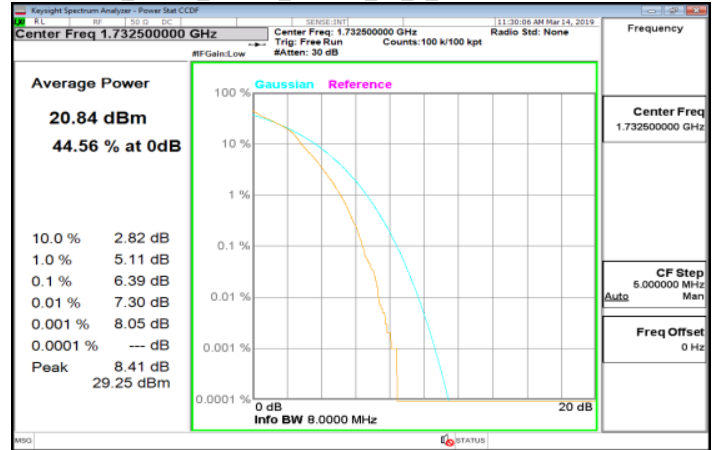

LTE_Band4_5MHz_16QAM_25_0_HighCH20375-1752.5

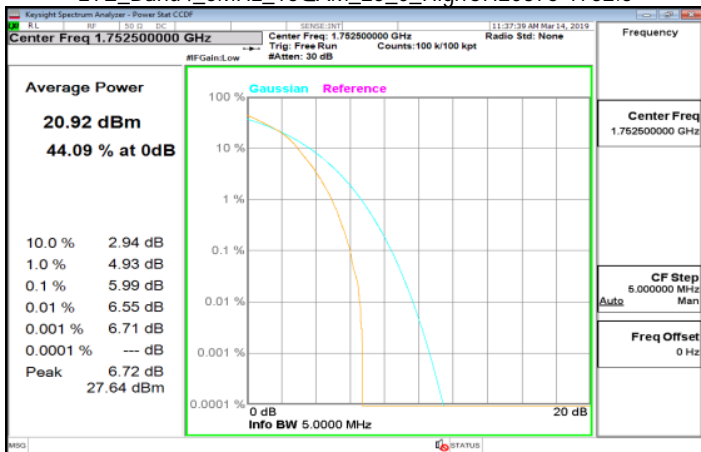

LTE_Band4_10MHz_16QAM_50_0_HighCH20350-1750

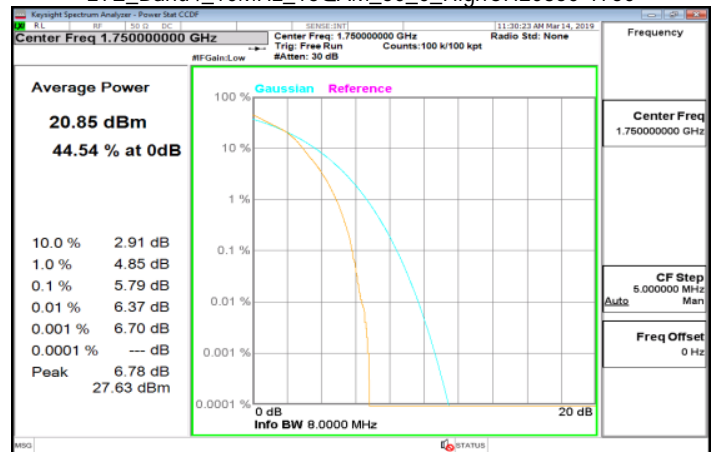

Unless otherwise stated the results shown in this test report refer only to the sample(s) tested and such sample(s) are retained for 90 days only.

除非另有說明，此報告結果僅對測試之樣品負責，同時此樣品僅保留90天。本報告未經本公司書面許可，不可部份複製。

This document is issued by the Company subject to its General Conditions of Service printed overleaf, available on request or accessible at www.sgs.com/terms_and_conditions.htm and for electronic format documents, subject to Terms and Conditions for Electronic Documents at www.sgs.com/terms_e-document.htm. Attention is drawn to the limitation of liability, indemnification and jurisdiction issues defined therein. Any holder of this document is advised that information contained hereon reflects the Company's findings at the time of its intervention only and within the limits of Client's instructions, if any. The Company's sole responsibility is to its Client and this document does not exonerate parties to a transaction from exercising all their rights and obligations under the transaction documents. This document cannot be reproduced except in full, without prior written approval of the Company. Any unauthorized alteration, forgery or falsification of the content or appearance of this document is unlawful and offenders may be prosecuted to the fullest extent of the law.

LTE_Band4_15MHz_16QAM_75_0_LowCH20025-1717.5

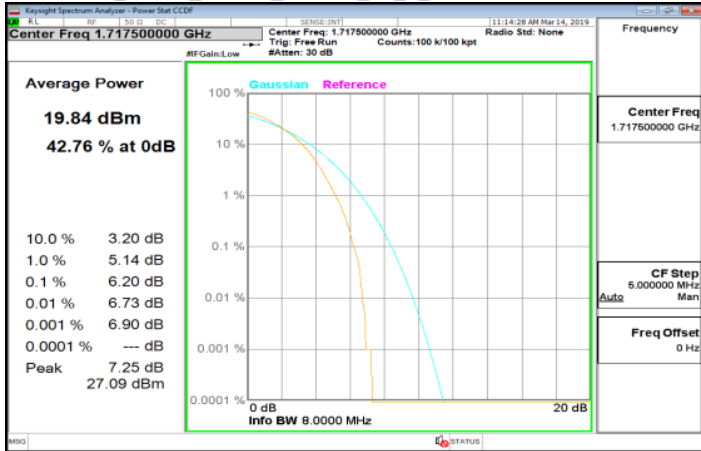

LTE_Band4_20MHz_16QAM_100_0_LowCH20050-1720

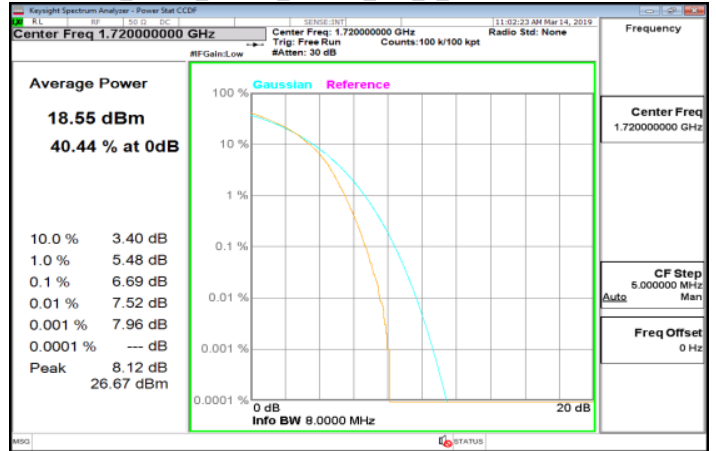

LTE_Band4_15MHz_16QAM_75_0_MidCH20175-1732.5

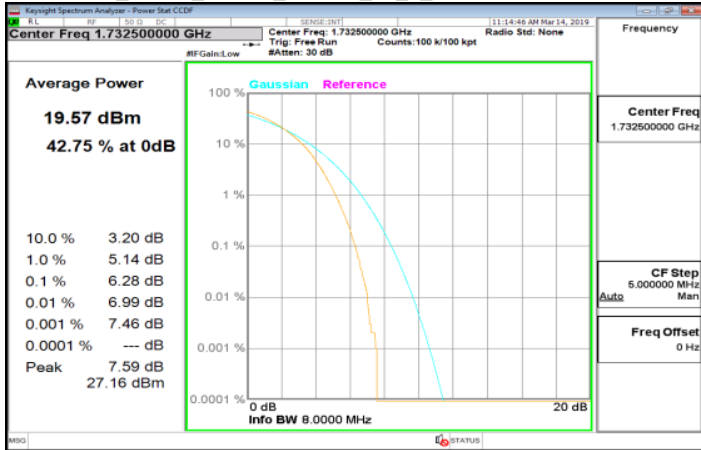

LTE_Band4_20MHz_16QAM_100_0_MidCH20175-1732.5

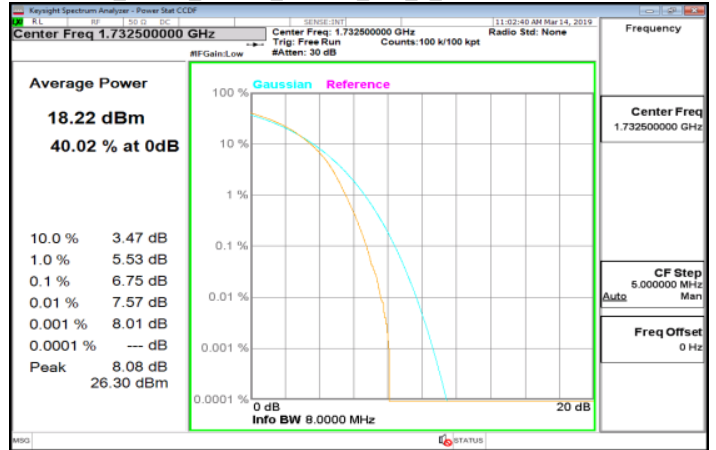

LTE_Band4_15MHz_16QAM_75_0_HighCH20325-1747.5

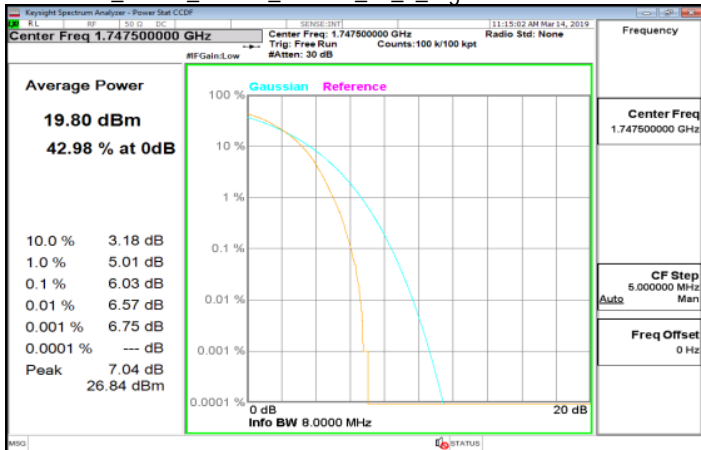

LTE_Band4_20MHz_16QAM_100_0_HighCH20300-1745

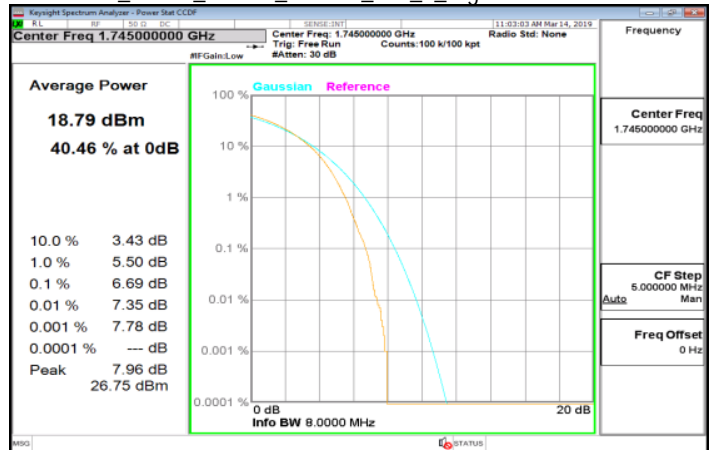

Unless otherwise stated the results shown in this test report refer only to the sample(s) tested and such sample(s) are retained for 90 days only.

除非另有說明，此報告結果僅對測試之樣品負責，同時此樣品僅保留90天。本報告未經本公司書面許可，不可部份複製。

This document is issued by the Company subject to its General Conditions of Service printed overleaf, available on request or accessible at www.sgs.com/terms_and_conditions.htm and for electronic format documents, subject to Terms and Conditions for Electronic Documents at www.sgs.com/terms_e-document.htm. Attention is drawn to the limitation of liability, indemnification and jurisdiction issues defined therein. Any holder of this document is advised that information contained hereon reflects the Company's findings at the time of its intervention only and within the limits of Client's instructions, if any. The Company's sole responsibility is to its Client and this document does not exonerate parties to a transaction from exercising all their rights and obligations under the transaction documents. This document cannot be reproduced except in full, without prior written approval of the Company. Any unauthorized alteration, forgery or falsification of the content or appearance of this document is unlawful and offenders may be prosecuted to the fullest extent of the law.

LTE_Band5_1_4MHz_16QAM_6_0_LowCH20407-824.7

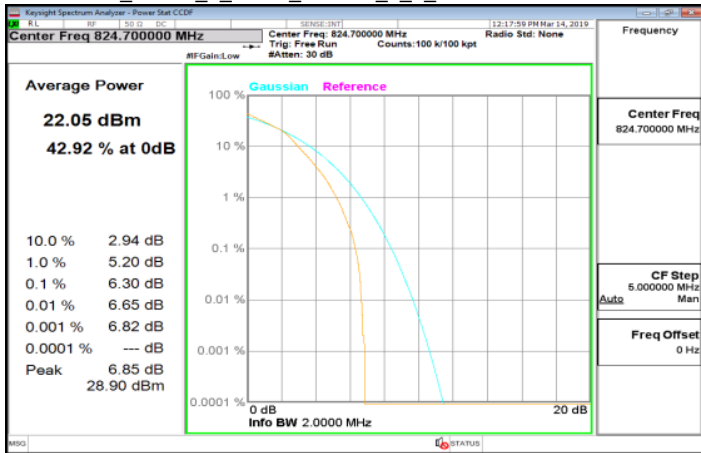

LTE_Band5_3MHz_16QAM_15_0_LowCH20415-825.5

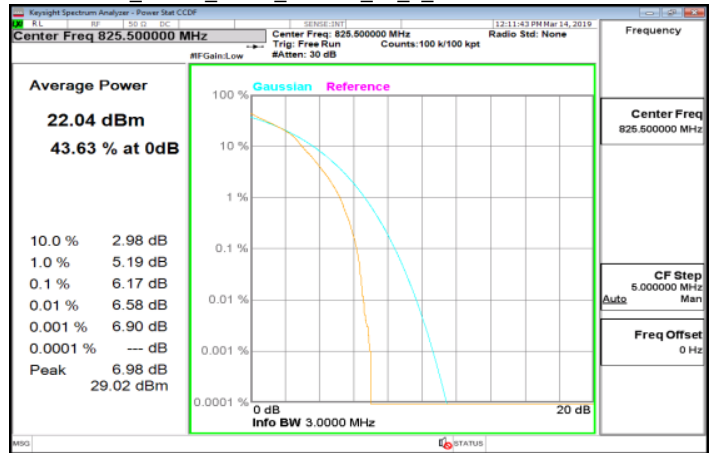

LTE_Band5_1_4MHz_16QAM_6_0_MidCH20525-836.5

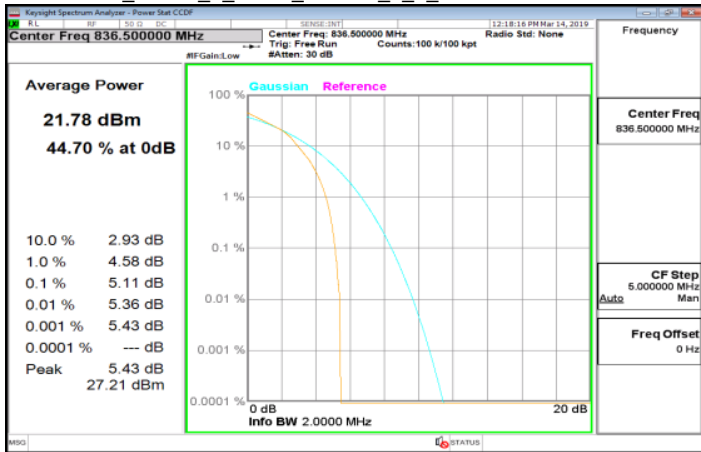

LTE_Band5_3MHz_16QAM_15_0_MidCH20525-836.5

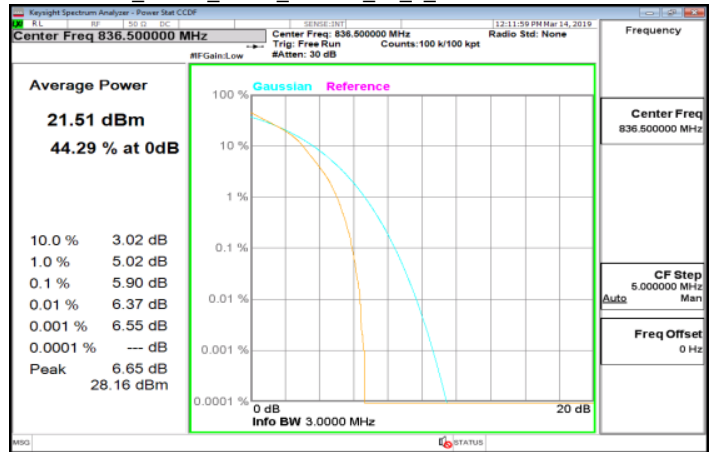

LTE_Band5_1_4MHz_16QAM_6_0_HighCH20643-848.3

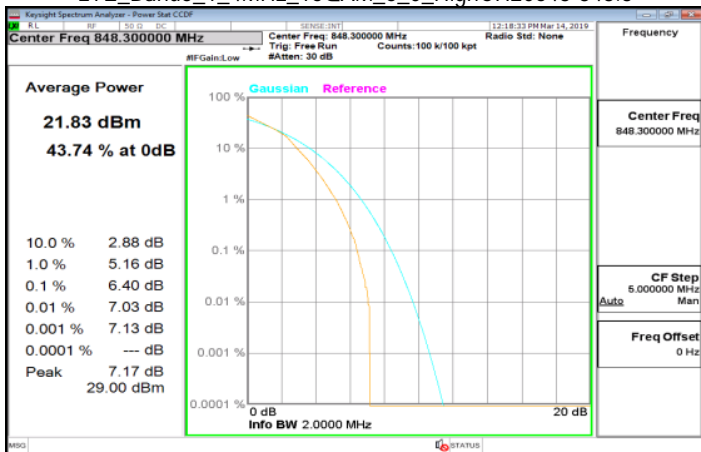

LTE_Band5_3MHz_16QAM_15_0_HighCH20635-847.5

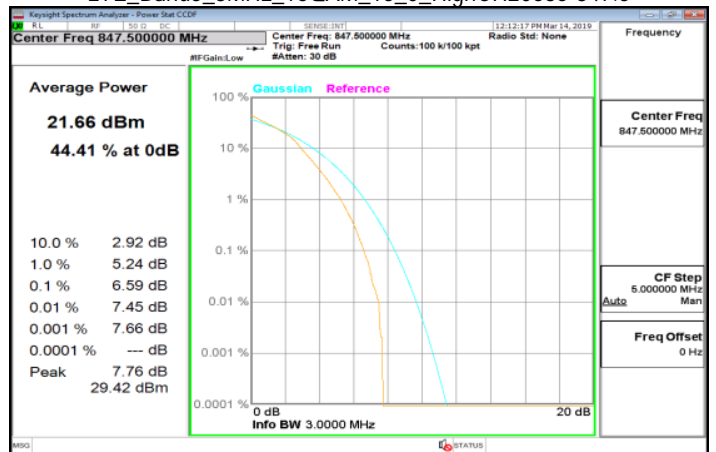

Unless otherwise stated the results shown in this test report refer only to the sample(s) tested and such sample(s) are retained for 90 days only.

除非另有說明，此報告結果僅對測試之樣品負責，同時此樣品僅保留90天。本報告未經本公司書面許可，不可部份複製。

This document is issued by the Company subject to its General Conditions of Service printed overleaf, available on request or accessible at www.sgs.com/terms_and_conditions.htm and for electronic format documents, subject to Terms and Conditions for Electronic Documents at www.sgs.com/terms_e-document.htm. Attention is drawn to the limitation of liability, indemnification and jurisdiction issues defined therein. Any holder of this document is advised that information contained hereon reflects the Company's findings at the time of its intervention only and within the limits of Client's instructions, if any. The Company's sole responsibility is to its Client and this document does not exonerate parties to a transaction from exercising all their rights and obligations under the transaction documents. This document cannot be reproduced except in full, without prior written approval of the Company. Any unauthorized alteration, forgery or falsification of the content or appearance of this document is unlawful and offenders may be prosecuted to the fullest extent of the law.

LTE_Band5_5MHz_16QAM_25_0_LowCH20425-826.5

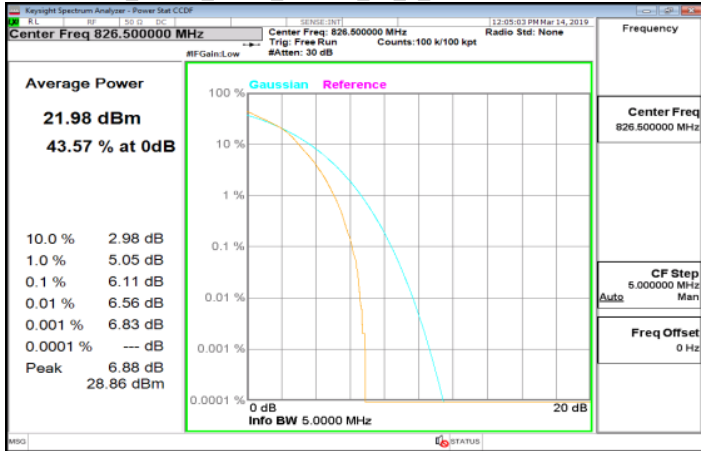

LTE_Band5_10MHz_16QAM_50_0_LowCH20450-829

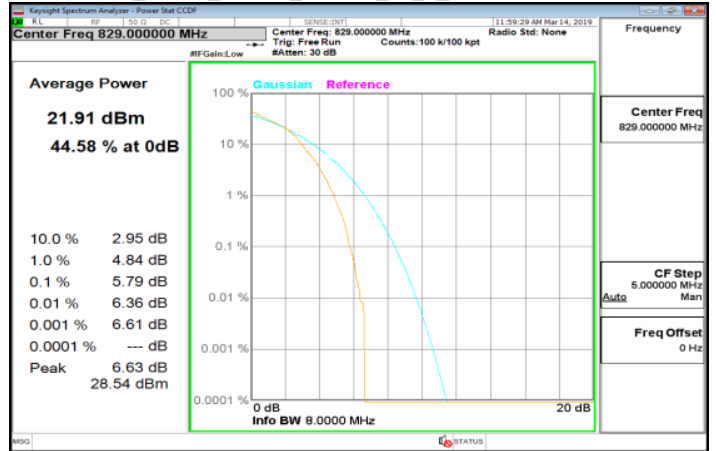

LTE_Band5_5MHz_16QAM_25_0_MidCH20525-836.5

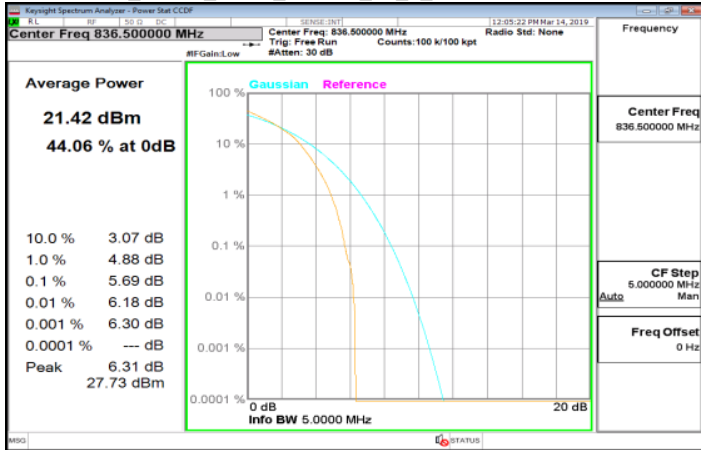

LTE_Band5_10MHz_16QAM_50_0_MidCH20525-836.5

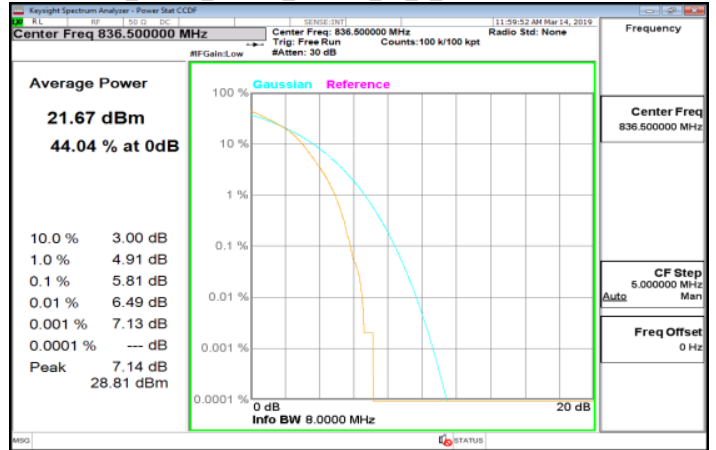

LTE_Band5_5MHz_16QAM_25_0_HighCH20625-846.5

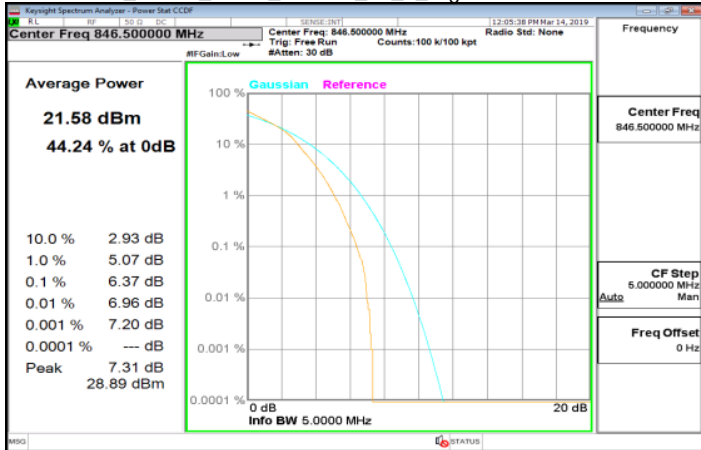

LTE_Band5_10MHz_16QAM_50_0_HighCH20600-844

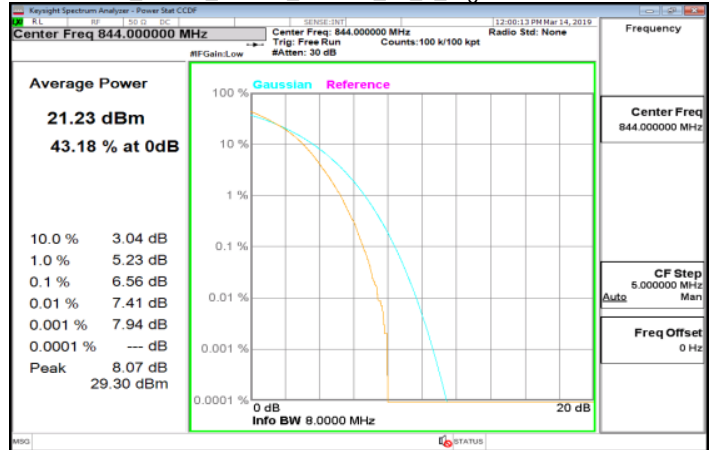

Unless otherwise stated the results shown in this test report refer only to the sample(s) tested and such sample(s) are retained for 90 days only.

除非另有說明，此報告結果僅對測試之樣品負責，同時此樣品僅保留90天。本報告未經本公司書面許可，不可部份複製。

This document is issued by the Company subject to its General Conditions of Service printed overleaf, available on request or accessible at www.sgs.com/terms_and_conditions.htm and for electronic format documents, subject to Terms and Conditions for Electronic Documents at www.sgs.com/terms_e-document.htm. Attention is drawn to the limitation of liability, indemnification and jurisdiction issues defined therein. Any holder of this document is advised that information contained hereon reflects the Company's findings at the time of its intervention only and within the limits of Client's instructions, if any. The Company's sole responsibility is to its Client and this document does not exonerate parties to a transaction from exercising all their rights and obligations under the transaction documents. This document cannot be reproduced except in full, without prior written approval of the Company. Any unauthorized alteration, forgery or falsification of the content or appearance of this document is unlawful and offenders may be prosecuted to the fullest extent of the law.

LTE_Band12_1_4MHz_16QAM_6_0_LowCH23017-699.7

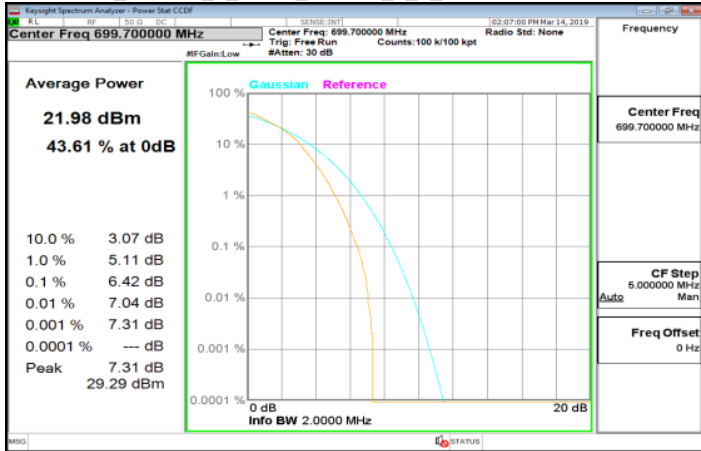

LTE_Band12_3MHz_16QAM_15_0_LowCH23025-700.5

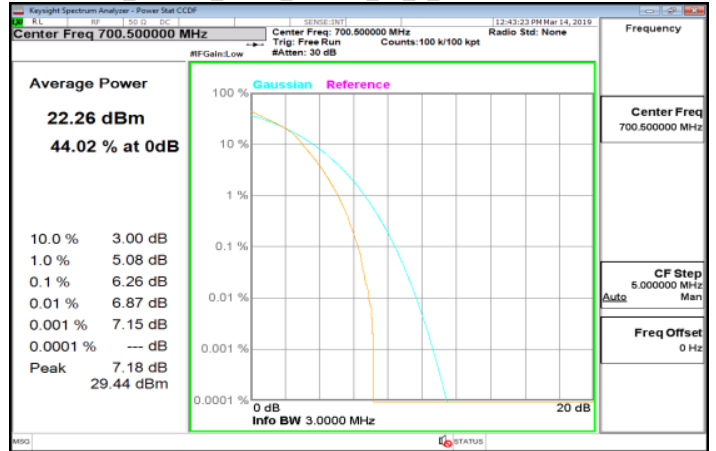

LTE_Band12_1_4MHz_16QAM_6_0_MidCH23095-707.5

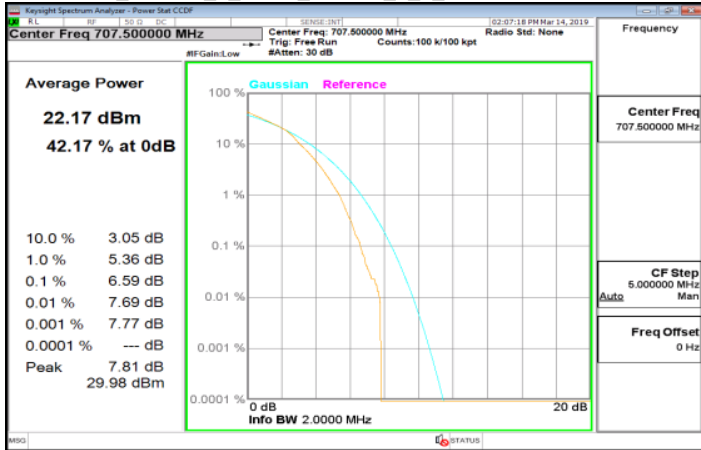

LTE_Band12_3MHz_16QAM_15_0_MidCH23095-707.5

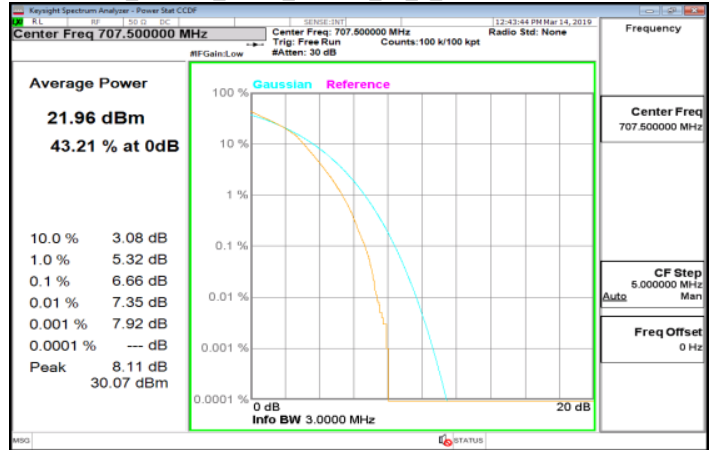

LTE_Band12_1_4MHz_16QAM_6_0_HighCH23173-715.3

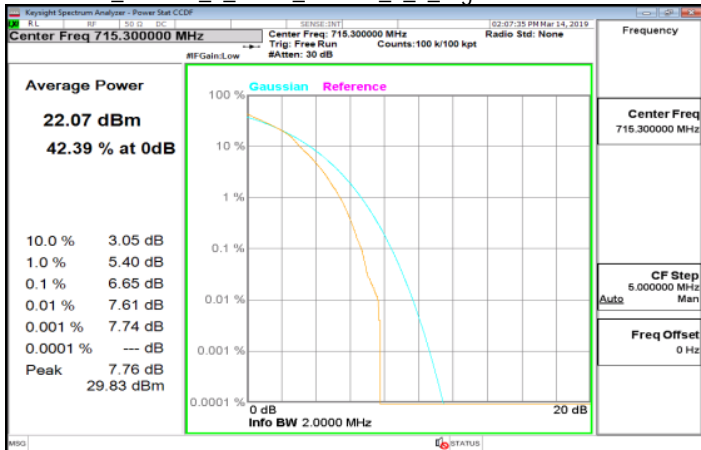

LTE_Band12_3MHz_16QAM_15_0_HighCH23165-714.5

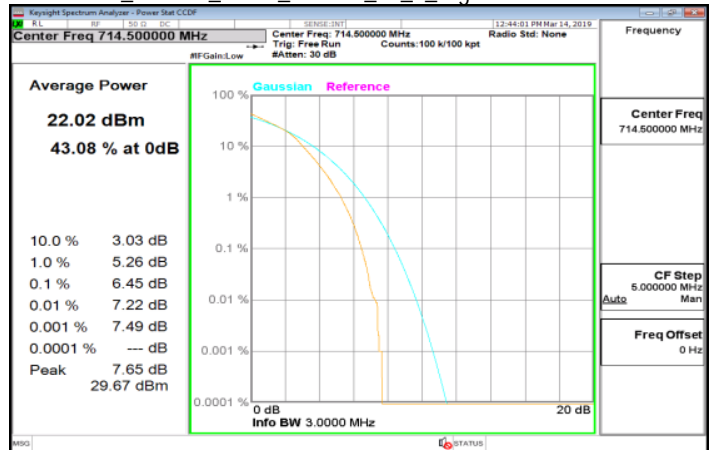

Unless otherwise stated the results shown in this test report refer only to the sample(s) tested and such sample(s) are retained for 90 days only.

除非另有說明，此報告結果僅對測試之樣品負責，同時此樣品僅保留90天。本報告未經本公司書面許可，不可部份複製。

This document is issued by the Company subject to its General Conditions of Service printed overleaf, available on request or accessible at www.sgs.com/terms_and_conditions.htm and for electronic format documents, subject to Terms and Conditions for Electronic Documents at www.sgs.com/terms_e-document.htm. Attention is drawn to the limitation of liability, indemnification and jurisdiction issues defined therein. Any holder of this document is advised that information contained hereon reflects the Company's findings at the time of its intervention only and within the limits of Client's instructions, if any. The Company's sole responsibility is to its Client and this document does not exonerate parties to a transaction from exercising all their rights and obligations under the transaction documents. This document cannot be reproduced except in full, without prior written approval of the Company. Any unauthorized alteration, forgery or falsification of the content or appearance of this document is unlawful and offenders may be prosecuted to the fullest extent of the law.

LTE_Band12_5MHz_16QAM_25_0_LowCH23035-701.5

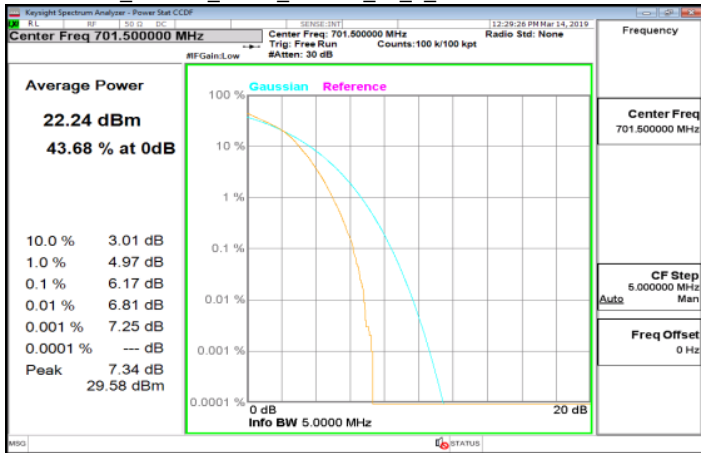

LTE_Band12_10MHz_16QAM_50_0_LowCH23060-704

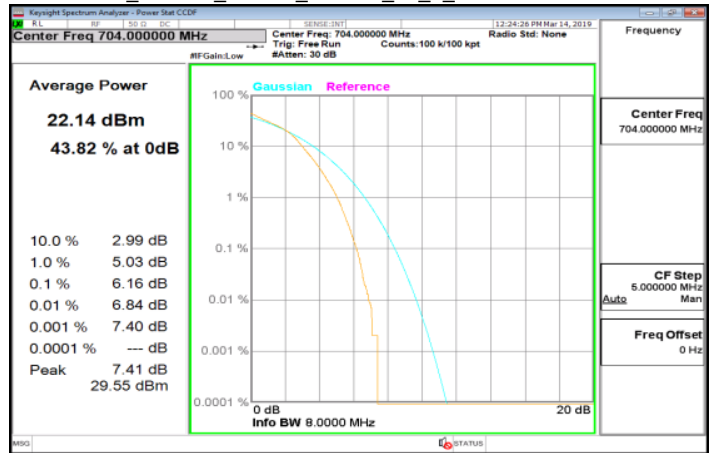

LTE_Band12_5MHz_16QAM_25_0_MidCH23095-707.5

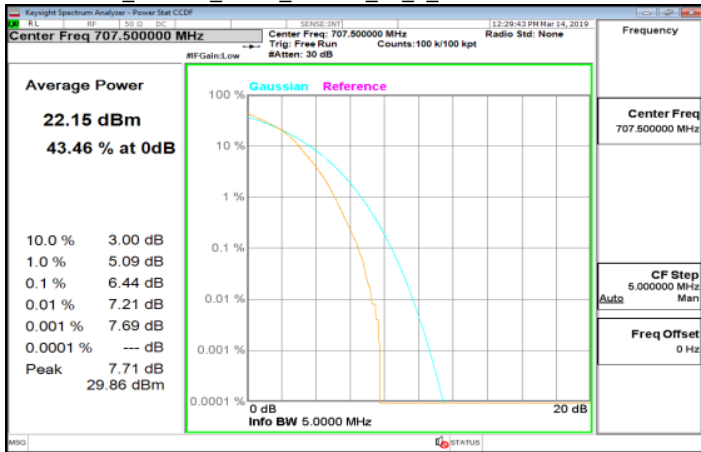

LTE_Band12_10MHz_16QAM_50_0_MidCH23095-707.5

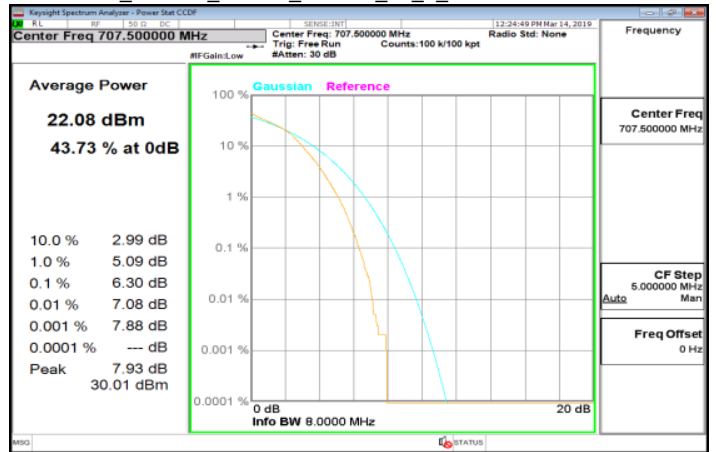

LTE_Band12_5MHz_16QAM_25_0_HighCH23155-713.5

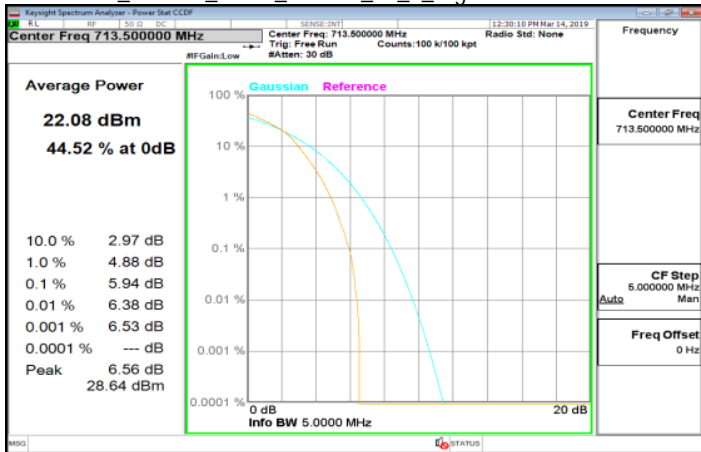

LTE_Band12_10MHz_16QAM_50_0_HighCH23130-711

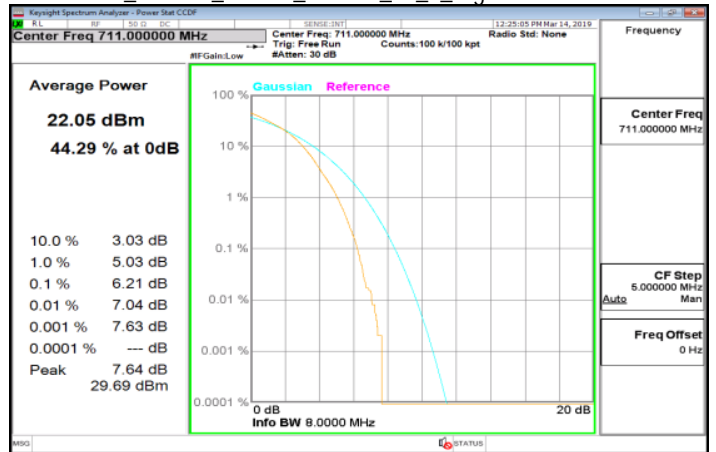

Unless otherwise stated the results shown in this test report refer only to the sample(s) tested and such sample(s) are retained for 90 days only.

除非另有說明，此報告結果僅對測試之樣品負責，同時此樣品僅保留90天。本報告未經本公司書面許可，不可部份複製。

This document is issued by the Company subject to its General Conditions of Service printed overleaf, available on request or accessible at www.sgs.com/terms_and_conditions.htm and for electronic format documents, subject to Terms and Conditions for Electronic Documents at www.sgs.com/terms_e-document.htm. Attention is drawn to the limitation of liability, indemnification and jurisdiction issues defined therein. Any holder of this document is advised that information contained hereon reflects the Company's findings at the time of its intervention only and within the limits of Client's instructions, if any. The Company's sole responsibility is to its Client and this document does not exonerate parties to a transaction from exercising all their rights and obligations under the transaction documents. This document cannot be reproduced except in full, without prior written approval of the Company. Any unauthorized alteration, forgery or falsification of the content or appearance of this document is unlawful and offenders may be prosecuted to the fullest extent of the law.