

AW-NH930

IEEE 802.11 a/b/g/n Wireless LAN, Bluetooth and FM Rx Combo Half Mini Card

Datasheet

Version 0.8

Inspired by wireless

Confidential

- Warning!! This is a message from Azurewave and the information you are viewing now is strictly confidential and is a knowledge property to Azurewave.
- Unauthorized use of this document is prohibited and Azurewave retains the right for legal actions against any loss suffered or expenditure due to the misuse of any information from this document.

Document release	Date	Modification	Initials	Approved
Version 0.1	2009/10/23	Initial Version	N.C. Chen	CE Huang
Version 0.2	2009/10/26	Modify pin definition	N.C. Chen	CE Huang
Version 0.3	2009/11/05	Modify pin definition VDDIO supply pin 24 change to pin 28	N.C. Chen	CE Huang
Version 0.4	2009/11/06	Modify pin definition Swap PCM/UART pins	N.C. Chen	CE Huang
Version 0.5	2010/4/21	Modify block diagram and mechanical information	N.C. Chen	CE Huang
Version 0.6	2010/6/02	Modify pin 44 & 46 description Add page25 Antenna Information Update 1-3 Specifications Table	N.C. Chen	CE Huang
Version 0.7	2010/12/14	Update Operating Temperature Add 2-7. Power-on sequence	N.C. Chen	CE Huang
Version 0.8	2010/12/24	Update 5.Antenna port information Output power 11a : 11 dBm (± 2 dBm)	N.C. Chen	CE Huang

AZUREWAVE CONFIDENTIAL

Inspired by wireless

Confidential

- Warning!! This is a message from Azurewave and the information you are viewing now is strictly confidential and is a knowledge property to Azurewave.
- Unauthorized use of this document is prohibited and Azurewave retains the right for legal actions against any loss suffered or expenditure due to the misuse of any information from this document.

Table of Contents

1. General Description

- 1-1. Product Overview and Functional Description
- 1-2. Key Features
- 1-3. Specifications Table

2. Electrical Characteristic

- 2-1. Absolute Maximum Ratings
- 2-2. Recommended Operating Conditions
- 2-3. DC Characteristics for Host I/O
- 2-4. BT/FM Host Interface
- 2-5. SDIO Timing
- 2-6. LPO Clock (RTC_CLK)
- 2-7. Power-On sequence

3. Pin Definition

- 3-1. Pin Description
- 3-2. Pin Description comparison with PCI-Express specification

4. Mechanical Information

5. Antenna port Information

1. General Description

1-1. Product Overview and Functional Description

AzureWave Technologies, Inc. introduces the first IEEE 802.11a/b/g/n WLAN, Bluetooth and FM combo module - **AW-NH930**. The module is targeted to mobile devices including, Digital Still Cameras (DSCs), Portable Media Players (PMPs), and Gaming Devices, mobile phones which need small footprint package, low power consumption, multiple OS support. By using AW-NH930, the customers can easily enable the Wi-Fi, BT and FM embedded applications with the benefits of **high design flexibility, short development cycle, and quick time-to-market**.

Compliance with the IEEE 802.11a/b/g/n standard, the AW-NH930 uses **DSSS, OFDM, DBPSK, DQPSK, CCK** and **QAM** baseband modulation technologies. A high level of integration and full implementation of the power management functions specified in the IEEE 802.11 standard minimize the system power requirements by using AW-NH930. In addition to the support of **WPA/WPA2 (personal)** and **WEP** encryption, the AW-NH930 also supports the **IEEE 802.11i** security standard through **AES** and **TKIP** acceleration hardware for faster data encryption. The AW-NH930 is also **Cisco Compatible Extension (CCX)** certified. For the video, voice and multimedia applications the AW-NH930 support **802.11e Quality of Service (QoS)**.

For Bluetooth operation, the AW-NH930 is **Bluetooth 2.1+Enhanced Data Rate (EDR)** compliant. The AW-NH930 supports **extended Synchronous Connections (eSCO)**, for enhanced voice quality by allowing for retransmission of dropped packets, and **Adaptive Frequency Hopping (AFH)** for reducing radio frequency interference. It provides easier to connect devices, lower power consumption and improved security.

For FM receiver/transmitter, the AW-NH930 is **76-MHz to 108-MHz** FM bands supported and supports the **European Radio Data Systems (RDS)** and the **North American Radio Broadcast Data System (RBDS)** modulations.

The AW-NH930 supports standard interface **SDIO v1.2 (4-bit and 1-bit)** for WLAN, **High-speed UART** interface for BT/FM host controller interface, and **PCM** for BT audio data. The demodulated FM audio signal is available as line-level analog stereo output. AW-NH930 is suitable for multiple mobile processors for different applications. With the combo functions and the good performance, the AW-NH930 is the best solution for the consumer electronics and the laptops.

1-2. Key Features

General

- ✦ Integrates Broadcom solutions of BCM4329 WiFi/BT/FM SoC
- ✦ SDIO interfaces support for WLAN
- ✦ ECI—enhanced coexistence support, ability to coordinate BT SCO transmissions around WLAN receives
- ✦ High speed UART and PCM for Bluetooth
- ✦ FM subsystem control through Bluetooth HCI interface
- ✦ Flexible Power Supply(2.3V~5.5V)
- ✦ Multiple power saving modes for low power consumption
- ✦ Lead-free /Halogen Free Design

WLAN

- ✦ Dual- band 2.4 GHz/5GHz 802.11 a/b/g/n
- ✦ Supports antenna diversity
- ✦ Supports IEEE 802.11d, e, h,i, j,r,k,w
- ✦ Security—WEP, WPA/WPA2 (personal), AES (HW), TKIP (HW), CKIP (SW).
- ✦ WMM/WMM-PS/WMM-SA
- ✦ Proprietary protocol –CCXv2/CCXv3/CCXv4/CCXv5, WFAEC
- ✦ Integrated CPU with on-chip memory for a complete WLAN subsystem minimizing the need to wake up the applications processor

Bluetooth

- ✦ Fully supports Bluetooth Core Specification version 2.1 + EDR features
- ✦ Support BT3.0+HS
- ✦ Maximum UART baud rates up to 4 Mbps
- ✦ Multipoint operation with up to seven active slaves

FM

- ✚ 76-MHz to 108-MHz FM bands supported (US, Europe, and Japan)
- ✚ RDS and RBDS demodulator and decoder with filter and buffering functions
- ✚ Auto search and tuning modes
- ✚ FM line-level analog stereo output available

Block Diagram

A simplified block diagram of the AW-NH930 module is depicted in the figure below.

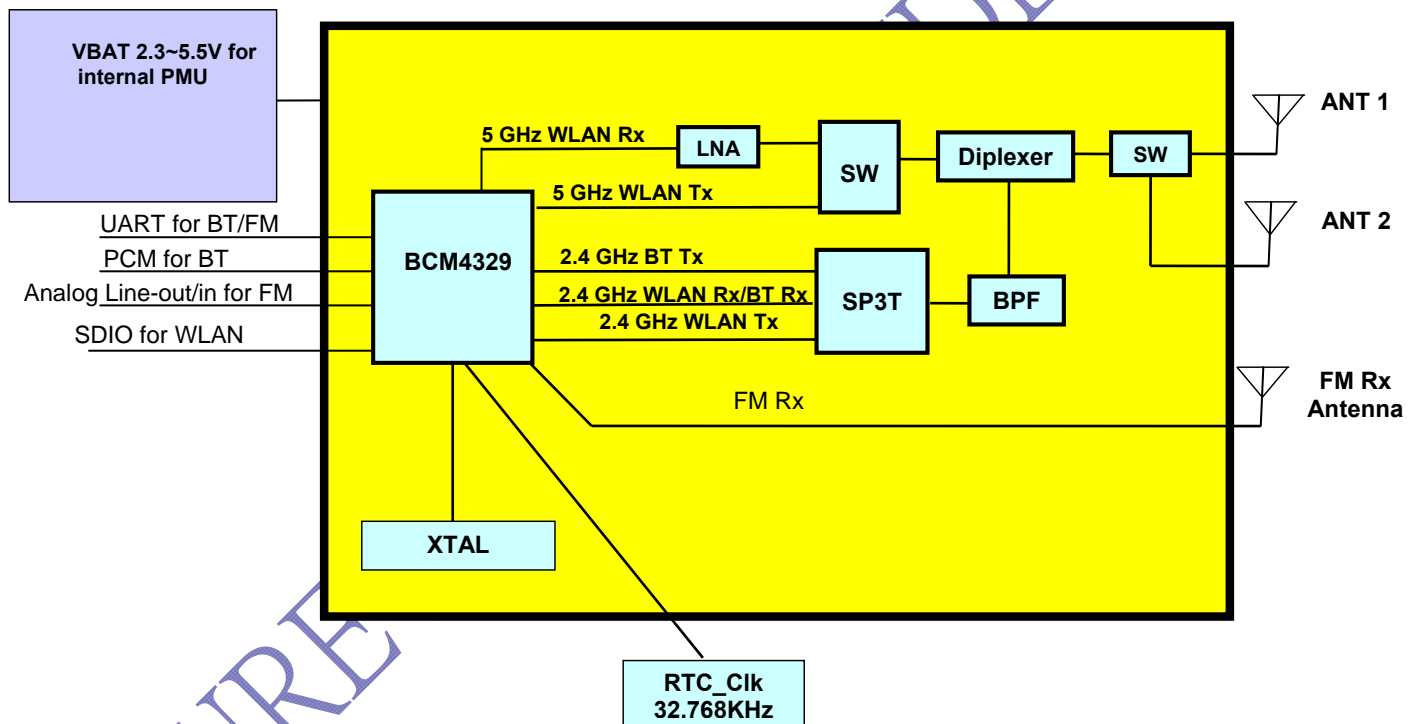

1-3. Specifications Table

*Specifications are subject to change without notice

Model Name	AW-NH930
Product Description	Wireless LAN &Bluetooth & FM
WLAN Standard	IEEE 802.11a/b/g/n, Wi-Fi compliant
Bluetooth Standard	Bluetooth 2.1+Enhanced Data Rate (EDR) / BT3.0+HS
Host Interface	SDIO for WLAN UART for Bluetooth and FM
Audio Interface	Digital PCM for Bluetooth. Analog line level i/o for FM.
Dimension	26.6 mm X 29.8 mm x 3.2 mm
Package	Half mini card package
Operating Conditions	
Voltage	Input supply for internal PMU: 2.3 ~ 5.5V Input supply for host I/O : 1.8 to 3.3V
Temperature	Operating: 0 ~ 70°C ; Storage: -40 ~ 85°C
Relative Humidity	< 60 % (storage) <85% (operation)
Electrical Specifications	
Frequency Range	2.4 GHz / 5GHz Band 76 MHz to 108 MHz FM bands
Number of Channels	802.11b: USA, Canada and Taiwan – 11 Most European Countries – 13 Japan – 14 802.11g: USA and Canada – 11 Most European Countries – 13 802.11a: USA – 19(24 optional) Most European Countries –19 Japan – 4
Modulation	*DSSS, OFDM, DBPSK, DQPSK, CCK, 16-QAM, 64-QAM for WLAN *GFSK (1Mbps), Π/4 DQPSK (2Mbps) and 8DPSK (3Mbps) for Bluetooth

Inspired by wireless

Confidential

- Warning!! This is a message from Azurewave and the information you are viewing now is strictly confidential and is a knowledge property to Azurewave.
- Unauthorized use of this document is prohibited and Azurewave retains the right for legal actions against any loss suffered or expenditure due to the misuse of any information from this document.

Output Power	WLAN: 11b: 16 dBm (\pm 2dBm) 11g: 15 dBm (\pm 2dBm) 11n: 13 dBm (\pm 2dBm) 11a: 11 dBm (\pm 2dBm) Bluetooth: 6.5 dBm (Typ.)
Receive Sensitivity	WLAN: 11b (11Mbps): -84 dBm 11g (54Mbps): -70 dBm 11n (HT20 MCS7): -66 dBm 11a (54Mbps): -70 dBm 11a (HT20 MCS7): -68 dBm Bluetooth: GFSK: -83 dBm $\pi/4$ -DQPSK: -86 dBm 8-DPSK: -81 dBm FM: 0 dBuV (Audio)
Data Rates	WLAN 802.11b: 1, 2, 5.5, 11Mbps 802.11g: 6, 9, 12, 18, 24, 36, 48, 54Mbps 802.11n:MCS 0~7 HT20 Bluetooth Bluetooth 2.1+EDR data rates of 1,2, and 3Mbps
Power Consumption	Not specified.
Operating Range	Open Space: ~300m ; Indoor: ~100m for WLAN Minimum 10 m indoor for Bluetooth (The transmission speed may vary according to the environment)
Security	<ul style="list-style-type: none"> ◆ WPA™- and WPA2™- (Personal) support for powerful encryption and authentication ◆ AES and TKIP acceleration hardware for faster data encryption and 802.11i compatibility ◆ Cisco® Compatible Extension- (CCX, CCX 2.0, CCX 3.0, CCX 4.0,CCX5.0) certified ◆ SecureEasySetup™ for simple Wi-Fi® setup and WPA2/WPA security configuration ◆ Wi-Fi Protected Setup (WPS) ◆ WEP ◆ CKIP(Software)
Operating System Compatibility	TBD

2. Electrical Characteristics

2-1. Absolute Maximum Ratings

Symbol	Parameter	Min	Max	Units
VDD_CORE	Power supply for Core Voltage	-0.5	1.32	V
VDDIO_SD	Host I/O power supply for WL	-0.5	4.1	V
VDDIO	I/O power supply for BT/FM/GPIO	-0.5	4.1	V
VBAT_IN	Power supply for Internal Regulators	-0.5	6.5	V
VDD_RADIO_PLL_IN	Power supply for Noise Sensitive Block (AFE,PLL...)	-0.5	1.32	V

2-2. Recommended Operating Conditions

Symbol	Parameter	Type	Min	Typ	Max	Units
VDD1P4_LDO_IN	Power supply for Internal CLDO/LDO1	Input	1.35	1.4	2	V
VDD_RADIO_PLL_IN	Power supply for Noise Sensitive Block (AFE,PLL...)	Input	1.1	1.225	1.35	V
VDD1P2_LDO1_OUT	Power supply from Internal LDO1	Output	1.1	1.225	1.35	V
VDD1P4_LNLD02_IN	Power supply for Internal LDO2	Input	1.35	1.4	2	V
VDD_BT_PA	Power supply for BT PA	Input		3.3		V
VDD_WL_PA	Power supply for WL PA G Mode	Input		3.3		V
VDD_WL_PA_A_MODE	Power supply for WL PA A Mode	Input		3.3		V
VBAT_IN	Power supply for Internal Regulators	Input	2.3		5.5	V
VDD_CORE	Power supply for Core Voltage	Input	1.1	1.225	1.35	V
VDD1P2_CLDO_OUT	Internal LDO for VDD_CORE	Output	1.1	1.225	1.35	V
VDDIO_SD	Host I/O power supply for WL	Input	1.62	1.8/3.3	3.63	V
VDDIO	I/O power supply for BT/FM/GPIO	Input	1.62	1.8/3.3	3.63	V
VDDIO_RF	I/O power supply for RF front-end	Input		3.3		V
SR_PA_OUT	Power Supply from Internal Buck/Boost Regulator	Output		3.3		V
VDD1P2_LNLD02_OUT	Power supply from Internal	Output	1.1	1.225	1.35	V
VDD_FM	Power Supply for FM	Input	1.1	1.225	1.35	V

2-3. DC Characteristics for Host I/O

Symbol	Parameter	Condition	Min	Typ	Max	Units
V_{IL}	Input low voltage (V_{DDIO} V_{DDIO_SD})	1.8V Logic			0.6	V
V_{IH}	Input high voltage (V_{DDIO} V_{DDIO_SD})	1.8V Logic	1.1			V
$V_{OL(-100\mu A \text{ Load})}$	Output low voltage (V_{DDIO} V_{DDIO_SD})	1.8V Logic			0.2	V
$V_{OH(-100\mu A \text{ Load})}$	Output high voltage (V_{DDIO})	1.8V Logic	$V_{IO} - 0.2V$			V
V_{IL}	Input low voltage (V_{DDIO} V_{DDIO_SD})	3.3V Logic			0.8	V
V_{IH}	Input high voltage (V_{DDIO} V_{DDIO_SD})	3.3V Logic	2.0			V
$V_{OL(-100\mu A \text{ Load})}$	Output low voltage (V_{DDIO} V_{DDIO_SD})	3.3V Logic			0.2	V
$V_{OH(-100\mu A \text{ Load})}$	Output high voltage (V_{DDIO})	3.3V Logic	$V_{IO} - 0.2V$			V

2-4. BT/FM Host Interface

The AW-NH930 is the optimal solution for any voice or data application that requires the Bluetooth SIG standard Host Controller Interface (HCI) using a high-speed UART. The FM subsystem and the Bluetooth subsystem share the same high-speed UART.

2-4-1. UART Interface

The UART physical interface is a standard, 4-wire interface (RX, TX, RTS, CTS) with adjustable baud rates from 9600 bps to 4.0 Mbps. The interface defaults to a baud rate of 115.2 Kbps coming out of reset. The desired high-speed baud rate may be selected via a vendor-specific UART HCI command. The AW-NH930 has a 480-byte receive FIFO and a 480-byte transmits FIFO to support EDR. The interface supports the Bluetooth 2.1 UART HCI (H4) specification. The default baud rate for H4 is 115.2 k baud. In order to support both high and low baud rates efficiently, the UART clock can be selected as either 24 or 48 MHz. Generally, the higher speed clock is needed for baud rates over 3 M baud, however a lower speed clock may be used to achieve a more accurate baud rate under 3 M baud.

The legacy method of programming the high-speed baud rate of the AW-NH930 UART using DHBR and DLBR values is also supported for backward compatibility with previous-generation Bluetooth devices.

Normally, the UART baud rate is set by a configuration record downloaded after reset, or by automatic baud rate detection and the host does not need to adjust the baud rate. Support for changing the baud rate during normal HCI UART operation is included through a vendor-specific command that allows the host to adjust the contents of the baud rate registers.

The AW-NH930 UART operates correctly with the host UART, provided the combined baud rate error of the two devices is within $\pm 5\%$

2-4-1.1. UART Interface Signals

Pin No	Pin Name	Description	Type
10	BT_UART_TXD	Bluetooth UART Serial Output Serial data output for the HCI UART Interface	O
12	BT_UART_RXD	Bluetooth UART Series Input Serial data input for the HCI UART Interface	I
14	BT_UART_RTS_N	Bluetooth UART Request to Send. Active-low request to send signal for the HCI UART interface	O
8	BT_UART_CTS_N	Bluetooth UART Clear to Send Active-low clear to send signal for the HCI UART interface.	I

2-4-1.2. UART Timing

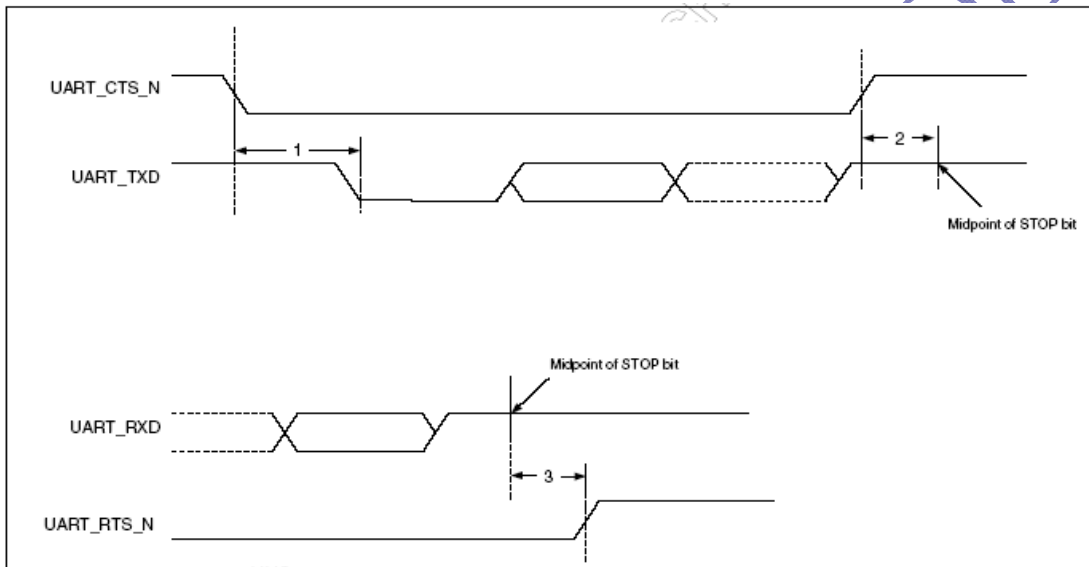

Values are specified in the recommended operating conditions unless otherwise specified.

Symbol	Description	Min	Typ	Max	Units
1	Delay time, BT_UART_CTS_N low to UART_TXD valid			24	Baudout cycles
2	Setup time, BT_UART_CTS_N high before midpoint of stop bit			10	ns
3	Delay time, midpoint of stop bit to BT_UART_RTS_N high			2	Baudout cycles

2-4-2. PCM Interface

The PCM Interface on the AW-NH930 can connect to linear PCM Codec devices in master or slave mode. In master mode, the AW-NH930 generates the BT_PCM_CLK and BT_PCM_SYNC signals, and in slave mode, these signals are provided by another master on the PCM interface and are inputs to the AW-NH930. The AW-NH930 supports up to three SCO or eSCO channels through the PCM Interface and each channel can be independently mapped to any of the available slots in a frame. The configuration of the PCM interface may be adjusted by the host through the use of Vendor Specific HCI Commands.

2-4-2.1. PCM Interface Signals

Pin No	Pin Name	Description	Type
17	BT_PCM_SYNC	PCM sync signal, can be master (output) or slave (input)	I/O
5	BT_PCM_OUT	PCM data output	O
3	BT_PCM_IN	PCM data input	I
19	BT_PCM_CLK	PCM clock, can be master (output) or slave (input)	I/O

2-4-2.2. PCM Interface Timing

Short Frame Sync, Master Mode

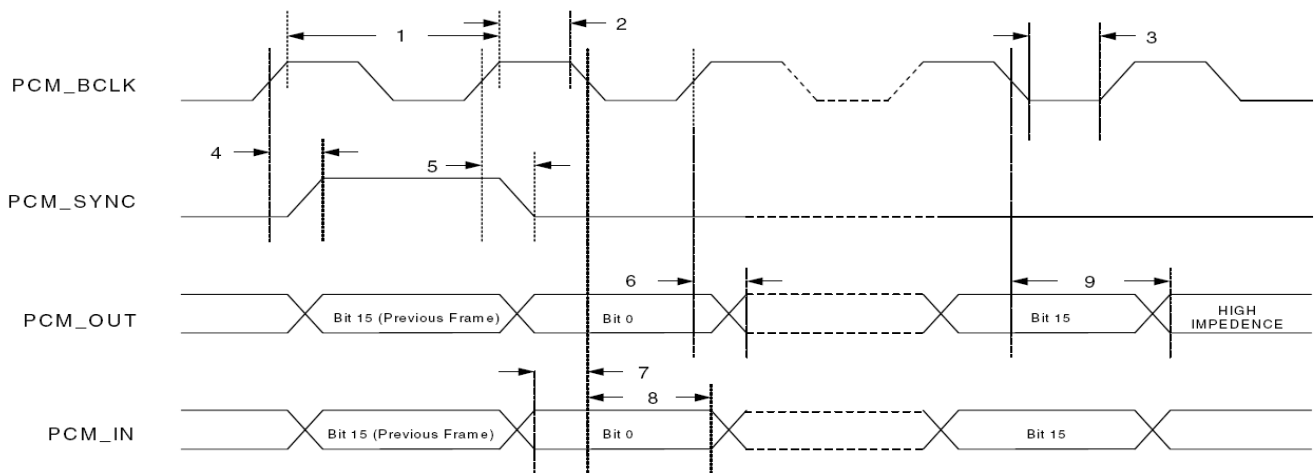

Values are specified in the recommended operating conditions unless otherwise specified.

Symbol	Description	Min	Typ	Max	Units
1	PCM bit clock frequency	128		2048	kHz
2	PCM bit clock high time	128			ns
3	PCM bit clock low time	209			ns
4	Delay from BT_PCM_CLK rising edge to BT_PCM_SYNC high			50	ns
5	Delay from BT_PCM_CLK rising edge to BT_PCM_SYNC low			50	ns
6	Delay from BT_PCM_CLK rising edge to data valid on BT_PCM_OUT			50	ns
7	Setup time for BT_PCM_IN before BT_PCM_CLK falling edge	50			ns
8	Hold time for BT_PCM_IN after BT_PCM_CLK falling edge	10			ns
9	Delay from falling edge of BT_PCM_CLK during last bit period to BT_PCM_OUT becoming high impedance			50	ns

Short Frame Sync, Slave Mode

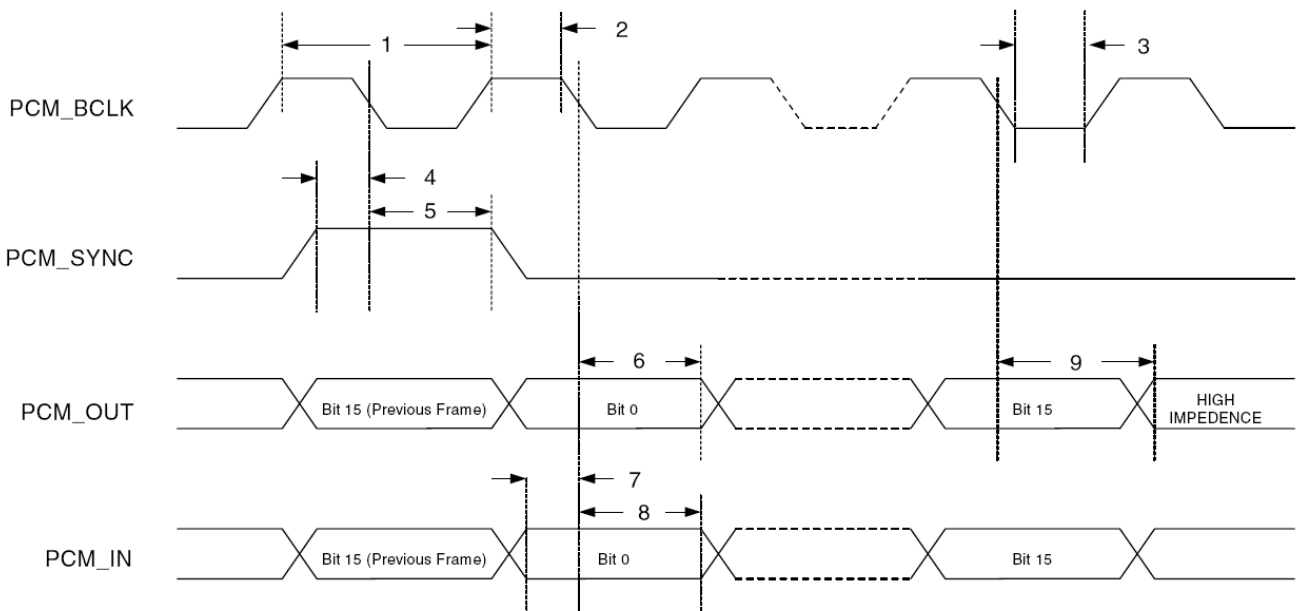

Values are specified in the recommended operating conditions unless otherwise specified.

Symbol	Description	Min	Typ	Max	Units
1	PCM bit clock frequency	128		2048	kHz
2	PCM bit clock high time	209			ns
3	PCM bit clock low time	209			ns
4	Setup time for BT_PCM_SYNC before falling edge of BT_PCM_BCLK	50			ns
5	Hold time for BT_PCM_SYNC after falling edge of BT_PCM_CLK	10			ns
6	Hold time of BT_PCM_OUT after BT_PCM_CLK falling edge			175	ns
7	Setup time for BT_PCM_IN before BT_PCM_CLK falling edge	50			ns
8	Hold time for BT_PCM_IN after BT_PCM_CLK falling edge	10			ns
9	Delay from falling edge of BT_PCM_CLK during last bit period to BT_PCM_OUT becoming high impedance			100	ns

Long Frame Sync, Master Mode

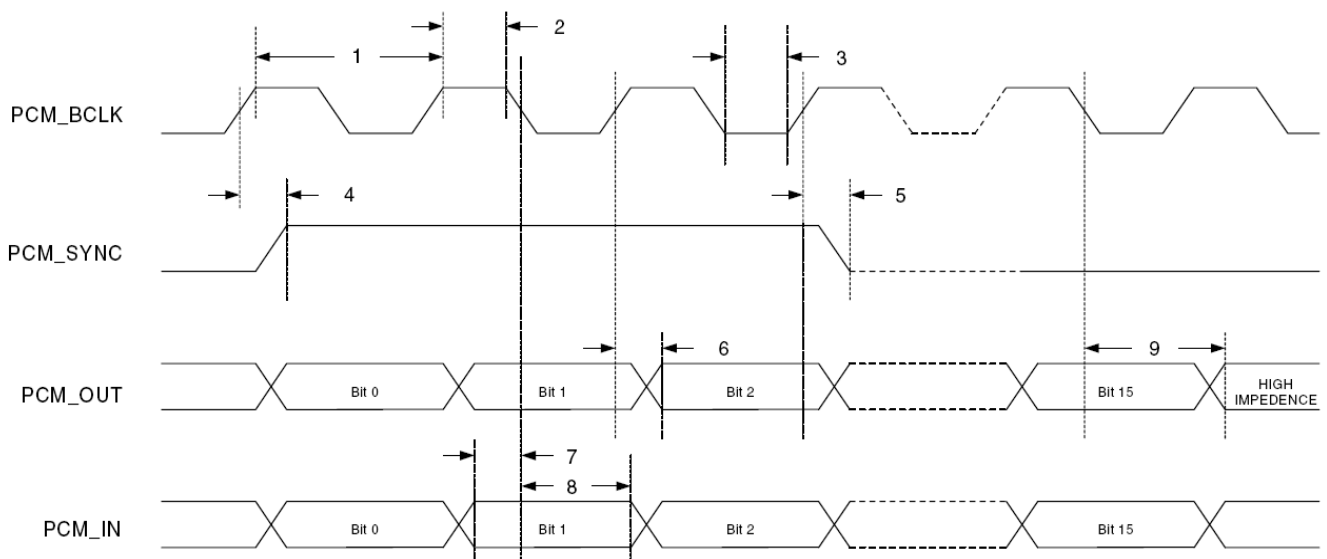

Values are specified in the recommended operating conditions unless otherwise specified.

Symbol	Description	Min	Typ	Max	Units
1	PCM bit clock frequency	128		2048	kHz
2	PCM bit clock high time	209			ns
3	PCM bit clock low time	209			ns
4	Delay from BT_PCM_CLK rising edge to BT_PCM_SYNC high during first bit time			50	ns
5	Delay from BT_PCM_CLK rising edge to BT_PCM_SYNC low during third bit time			50	ns
6	Delay from BT_PCM_CLK rising edge to data valid on BT_PCM_OUT			50	ns
7	Setup time for BT_PCM_IN before BT_PCM_CLK falling edge	50			ns
8	Hold time for BT_PCM_IN after BT_PCM_CLK falling edge	10			ns
9	Delay from falling edge of BT_PCM_CLK during last bit period to BT_PCM_OUT becoming high impedance			50	ns

Long Frame Sync, Slave Mode

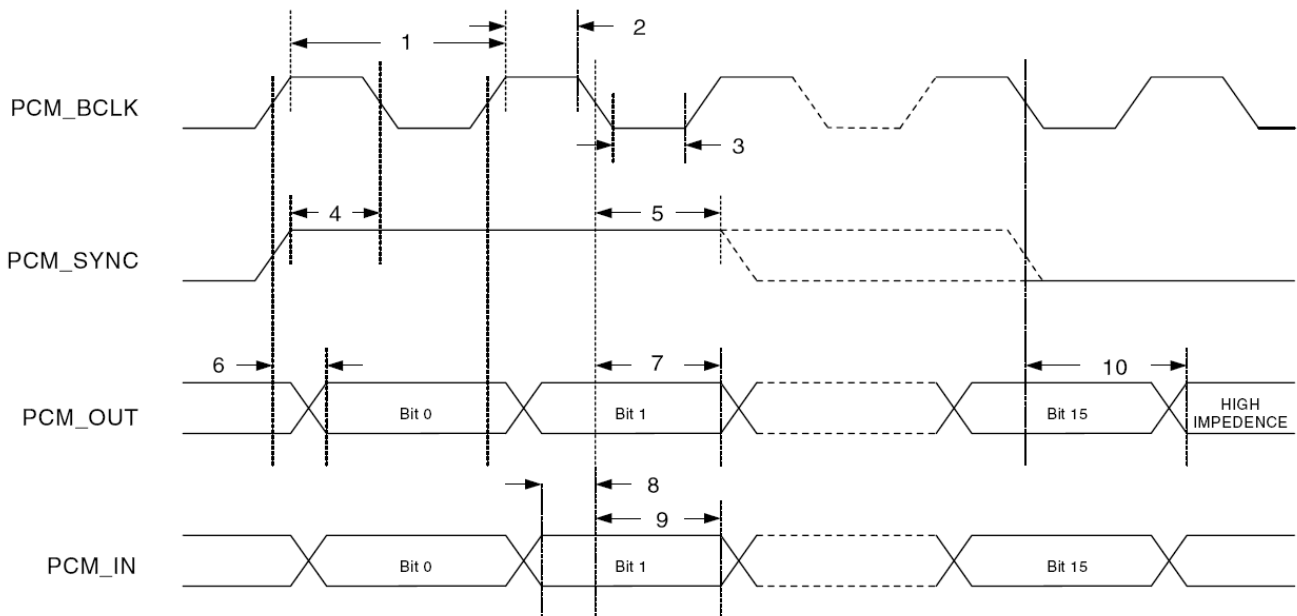

Values are specified in the recommended operating conditions unless otherwise specified.

Symbol	Description	Min	Typ	Max	Units
1	PCM bit clock frequency	128		2048	kHz
2	PCM bit clock high time	209			ns
3	PCM bit clock low time	209			ns
4	Setup time for BT_PCM_SYNC before falling edge of BT_PCM_CLK during first bit time	50			ns
5	Hold time for BT_PCM_SYNC after falling edge of BT_PCM_CLK during second bit period. (BT_PCM_SYNC may go low any time from second bit period to last bit period)	10			ns
6	Delay from rising edge of BT_PCM_CLK or BT_PCM_SYNC (whichever is later) to data valid for first bit on BT_PCM_OUT			50	ns
7	Hold time of BT_PCM_OUT after BT_PCM_CLK falling edge			175	ns
8	Setup time for BT_PCM_IN before BT_PCM_CLK falling edge	50			ns
9	Hold time for BT_PCM_IN after BT_PCM_CLK falling edge	10			
10	Delay from falling edge of BT_PCM_CLK or BT_PCM_SYNC (whichever is later) during last bit in slot to BT_PCM_OUT becoming high impedance			100	ns

2-5. SDIO Timing

The AW-NH930 has an internal power-on reset (POR) circuit. The device will be held in reset for a maximum of 110 ms after VDDC and VDDIO have both passed the 0.6V threshold. Wait at least 110 ms after VDD_CORE and VDDIO are available before initiating SDIO accesses. The external reset signals are logically ORed with this POR. So if either the internal POR or one of the external resets is asserted, the device will be in reset.

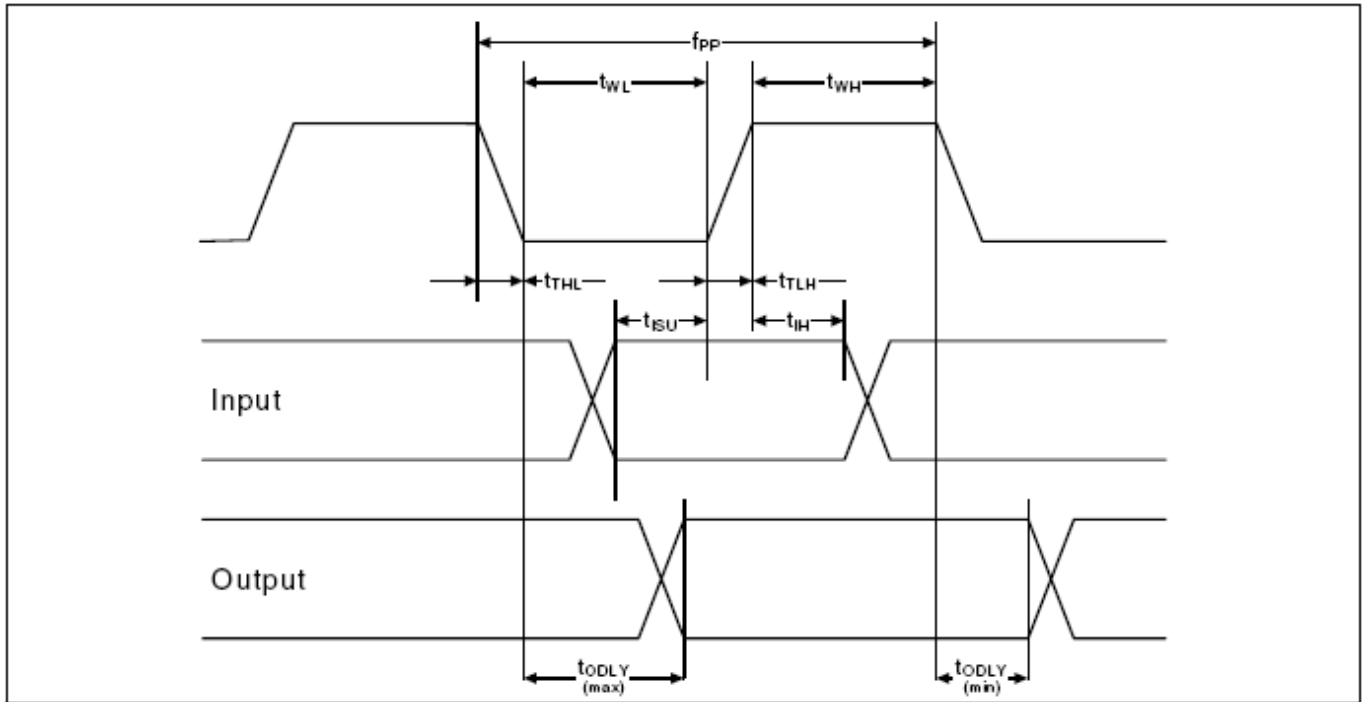
SDIO Bus Timing(1) (Default Mode)

Parameter	Symbol	Min	Typical	Max	Unit
Clock CLK (All values are referred to min. VIH and max. VIL²)					
Frequency—Data Transfer Mode	fPP	0	–	25	MHz
Frequency—Identification Mode	fOD	0	–	400	kHz
Clock Low Time	tWL	10	–	–	ns
Clock High Time	tWH	10	–	–	ns
Clock Rise time	tTLH	–	–	10	ns
Clock Low Time	tTHL	–	–	10	ns
Inputs: CMD, DAT (referenced to CLK)					
Input Setup Time	tISU	5	–	–	ns
Input Hold Time	tIH	5	–	–	ns
Outputs: CMD, DAT (referenced to CLK)					
Output Delay time—Data Transfer Mode	tODLY	0	–	14	ns
Output Delay time—Identification Mode	tODLY	0	–	50	ns

¹Timing is based on CL ≤40pF load on CMD and Data.

²min (Vih) = 0.7*Vdd and max (Vil) = 0.2*Vdd

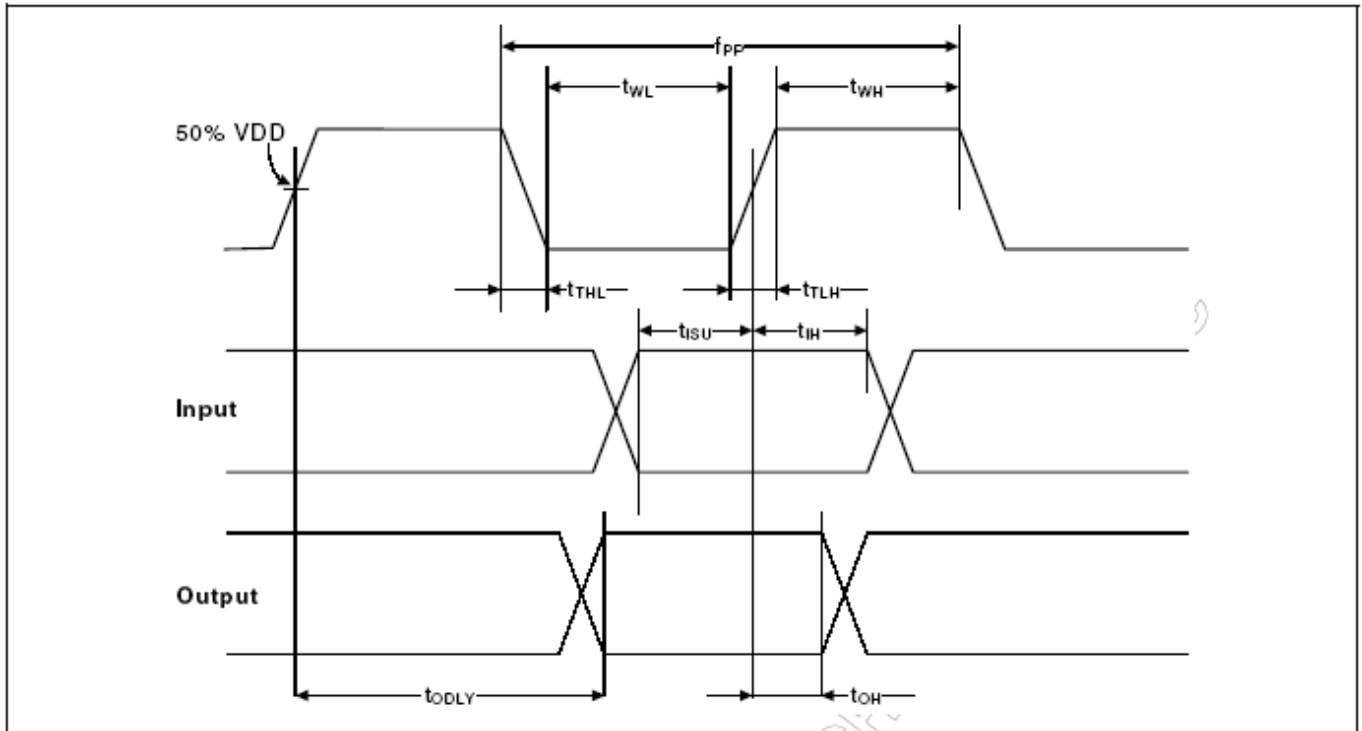
SDIO Bus Timing (High-Speed Mode)

Parameter	Symbol	Min	Typical	Max	Unit
Clock CLK (all values are referred to min. V_{IH} and max. V_{IL}^2)					
Frequency—Data Transfer Mode	f_{PP}	0	–	50	MHz
Frequency—Identification Mode	f_{OD}	0	–	400	kHz
Clock Low Time	t_{WL}	7	–	–	ns
Clock High Time	t_{WH}	7	–	–	ns
Clock Rise time	t_{TLH}	–	–	3	ns
Clock Low Time	t_{THL}	–	–	3	ns
Inputs: CMD, DAT (referenced to CLK)					
Input Setup Time	t_{ISU}	6	–	–	ns
Input Hold Time	t_{IH}	2	–	–	ns
Outputs: CMD, DAT (referenced to CLK)					
Output Delay time—Data Transfer Mode	t_{ODLY}	–	–	14	ns
Output Hold time	t_{OH}	2.5	–	–	ns
Total System Capacitance (each line)	CL	–	–	40	pF

¹Timing is based on $CL \leq 40pF$ load on CMD and Data.

²min (V_{ih}) = $0.7 \cdot V_{dd}$ and max (V_{il}) = $0.2 \cdot V_{dd}$

2-6. LPO Clock (RTC_CLK)

Parameter	LPO Clock	Units
Nominal input frequency	32.768	kHz
Frequency accuracy	±200 ^a	ppm
Duty cycle	30–70	%
Input signal amplitude	200 to 1800 ^b	mV, p-p
Signal type	Square-wave or sine-wave	–
Input impedance ^c	>100k	Ω
	< 5	pF
Clock jitter (integrated over 300 Hz – 15 kHz)	<1	Hz

- a. If FM is used: ±150 ppm maximum with frequency error indication, ± 50ppm without frequency error indication.
 b. 200–1800 mVp-p to avoid additional current consumption and degradation in FM SNR. 3.3 Vp-p maximum.
 c. When power is applied or switched off.

2-7. Power-On Sequence

The AW-NH931 has four signals that allow the host to control power consumption by enabling or disabling the Bluetooth, WLAN and internal regulator blocks. These signals are described below. Additionally, diagrams are provided to indicate proper sequencing of the signals for various operating states. The timing value indicated are minimum required values: longer delays are also acceptable.

Note: The WL_SHUTDOWN_N and BT_SHUTDOWN_N are ORed in the AW-NH931. The diagrams show both signals going high at the same time (as would be the case if both SHUTDOWN signals were controlled by a single host GPIO). If two independent host GPIOs are used (one for WL_SHUTDOWN_N and one for BT_SHUTDOWN_N), then only one of two signals needs to be high to enable the AW-NH931 regulators.

Also note that the reset requirements for the Bluetooth core are also applicable for the FM core. In other words, if FM is to be used, then the Bluetooth core must be enabled.

WL_SHUTDOWN_N: Used by the PMU (along with BT_SHUTDOWN_N) to decide whether to power down the internal AW-NH931 regulators. If both the BT_SHUTDOWN_N and WL_SHUTDOWN_N pins are low, the regulators will be disabled.

BT_SHUTDOWN_N: Used by the PMU (along with WL_SHUTDOWN_N) to decide whether to power down the internal AW-NH931 regulators. If both the BT_SHUTDOWN_N and WL_SHUTDOWN_N pins are low, the regulators will be disabled.

WL_RST_N: Low asserting Reset for WLAN Core. This pin must be driven high or low (not left floating).
BT_RST_N: Low asserting Reset for Bluetooth Core. This pin must be driven high or low (not left floating).

2-7.1 Power on sequence for WLAN=ON and Bluetooth=ON

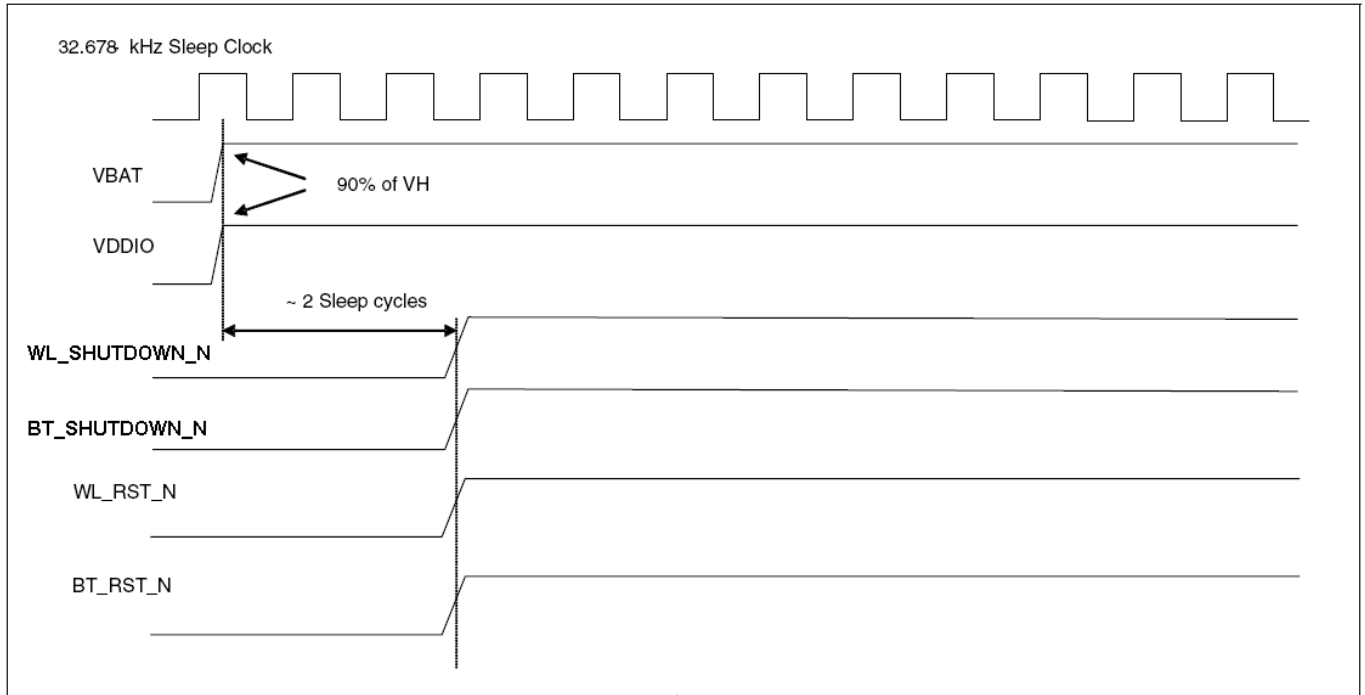

2-7.2 Power on sequence for WLAN=OFF and Bluetooth=OFF

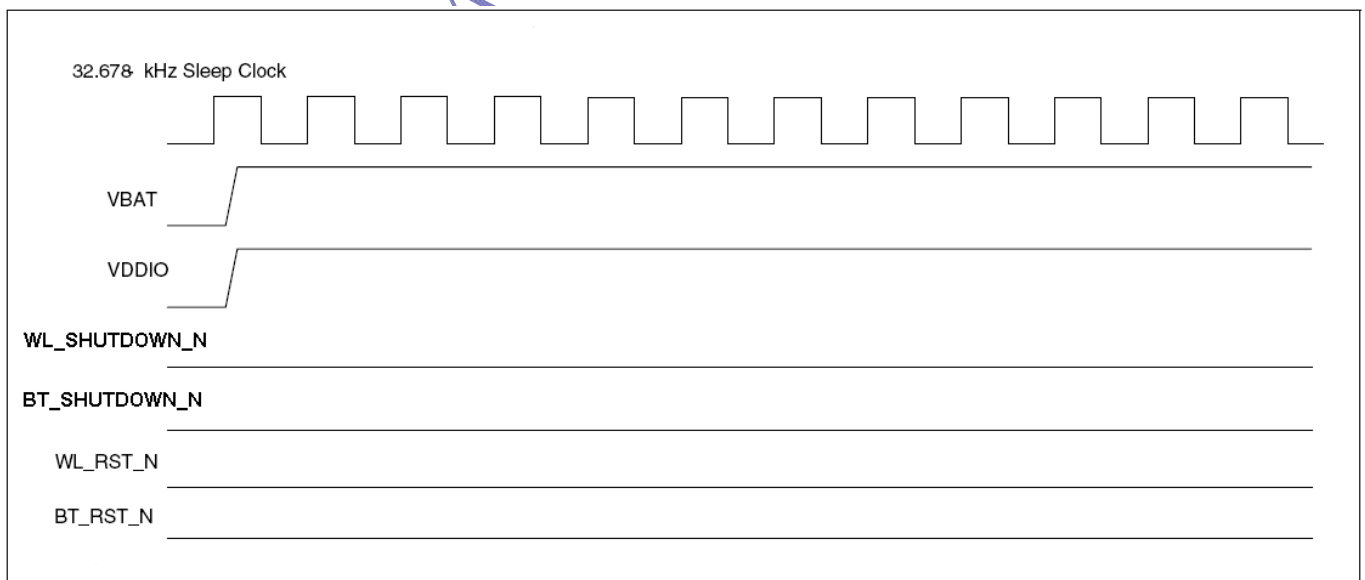

2-7.3 Power on sequence for WLAN=ON and Bluetooth=OFF

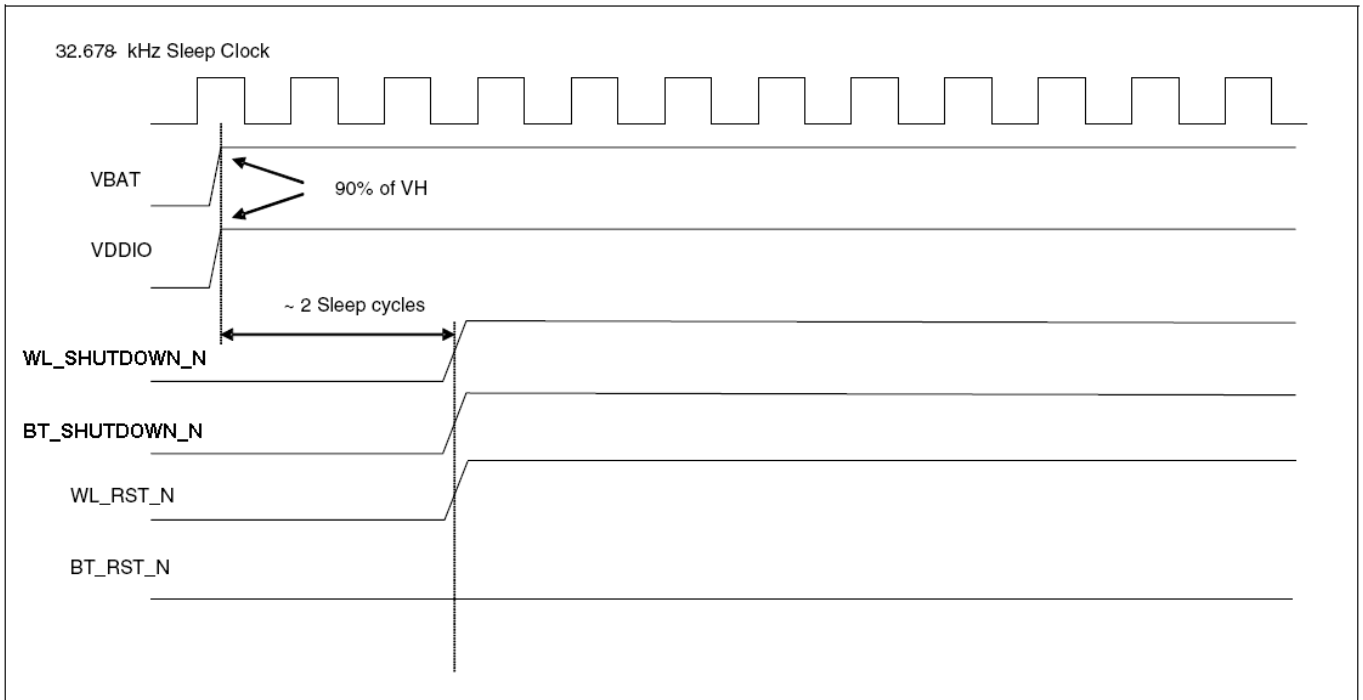

2-7.4 Power on sequence for WLAN=OFF and Bluetooth=ON

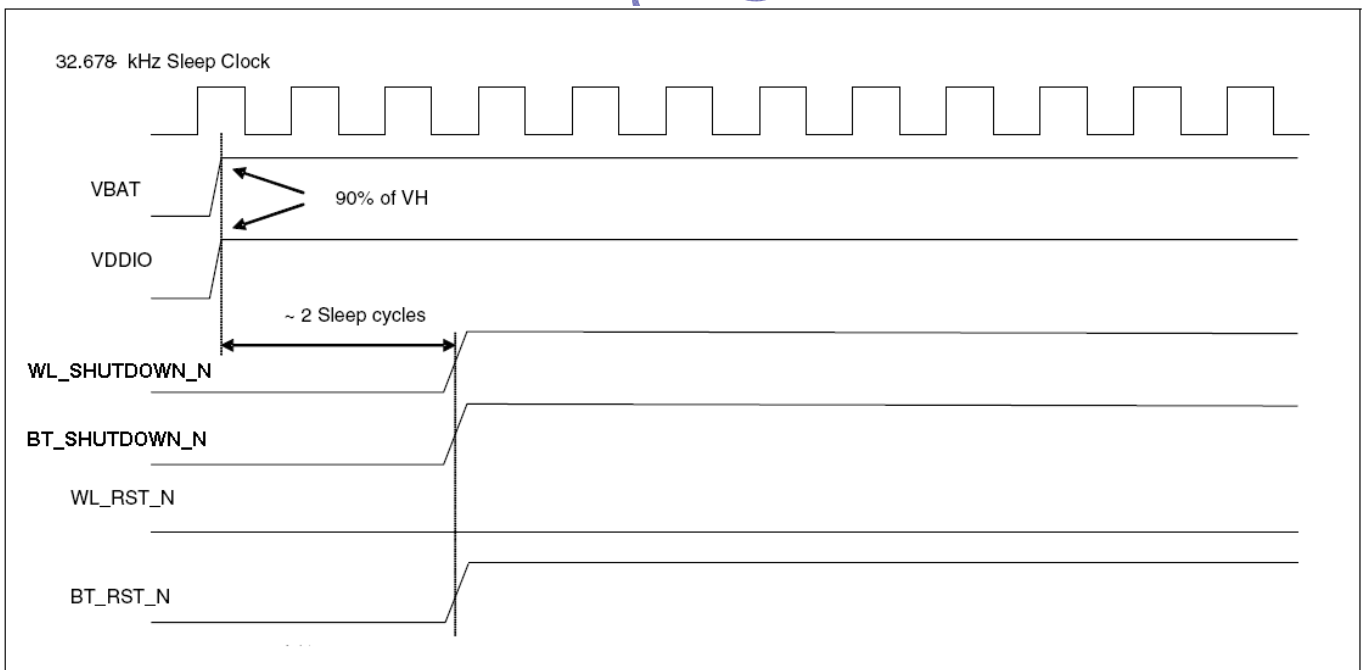

3. Pin Definition

3-1. Pin Description

Pin No	Pin Name	Description	Type
1	WL_HOST_WAKE	Host wake up. Signal from the AW-NH930 to the host indicating that the WLAN device requires attention. <ul style="list-style-type: none"> Asserted: Host device must wake-up or remain awake. Deasserted: Host device may sleep when sleep criteria are met. The polarity of this signal is software configurable and can be asserted high or low.	O
2	VBAT3V3_IN	Power supply for Internal regulators	I
3	BT_PCM_IN	PCM data input (Pin definition for module side)	I
4	GND	Ground	
5	BT_PCM_OUT	PCM data output (Pin definition for module side)	O
6	NC	No Connect	
7	BT_HOST_WAKE	Host wake up. Signal from the AW-NH930 to the host indicating that the Bluetooth device requires attention. <ul style="list-style-type: none"> Asserted: Host device must wake-up or remain awake. Deasserted: Host device may sleep when sleep criteria are met. The polarity of this signal is software configurable and can be asserted high or low.	O
8	BT_UART_CTS_N	Bluetooth UART Clear to Send Active-low clear to send signal for the HCI UART interface. (Pin definition for module side)	I
9	GND	Ground	
10	BT_UART_TXD	Bluetooth UART Serial Output Serial data output for the HCI UART Interface (Pin definition for module side)	O
11	FM_AUDIO_L	FM Rx analog audio output channel Left (DC Block Capacitor Required)	O
12	BT_UART_RXD	Bluetooth UART Series Input Serial data input for the HCI UART Interface (Pin definition for module side)	I
13	FM_AUDIO_R	FM Rx analog audio output channel Reft (DC Block Capacitor Required)	O
14	BT_UART_RTS_N	Bluetooth UART Request to Send. Active-low request to send signal for the HCI UART interface (Pin definition for module side)	O
15	GND	Ground	
16	BT_WAKE	Bluetooth device wake-up: Signal from the host to the AW-NH930 indicating that the host requires attention. <ul style="list-style-type: none"> Asserted: Bluetooth device must wake-up or remain awake. Deasserted: Bluetooth device may sleep when sleep criteria are met. The polarity of this signal is software configurable and can be asserted high or low.	I
17	BT_PCM_SYNC	PCM sync signal, can be master (output) or slave (input) (Pin definition for module side)	
18	GND	Ground	
19	BT_PCM_CLK	PCM clock, can be master (output) or slave (input) (Pin definition for module side)	I/O

Pin No	Pin Name	Description	Type
20	BT_RST_N	Low Asserting Reset for Bluetooth Core.	I
21	GND	Ground	
22	WL_RST_N	Low asserting reset for WLAN.	I
23	NC	No Connect	
24	VBAT3V3_IN	Power supply for Internal regulators	I
25	NC	No Connect	
26	GND	Ground	
27	GND	Ground	
28	VDDIO	Digital I/O power supply for WL/BT/FM (1.8V~3.3V)	I
29	GND	Ground	
30	NC	No Connect	
31	NC	No Connect	
32	NC	No Connect	
33	NC	No Connect	
34	GND	Ground	
35	GND	Ground	
36	NC	No Connect	
37	SDIO_DATA2_SPI_NC	<p>SDIO 4-bit Mode: Data line 2 or Read Wait SDIO 1-bit Mode: Read Wait This pin has an internal weak pull-up resistor. The resistor is enabled by default but can be disabled by software. The value of the pull-up depends on the VDDIO_SD supply voltage. For 1.8V, the resistance range is 30–82 k Ohms. For 2.6V, it ranges from 21–41 k Ohms. For 3.3V, it ranges from 15–35 k Ohms .</p>	I/O
38	NC	No Connect	
39	SDIO_CLK_SPI_CLK	SDIO Clock (Pin definition for module side)	I
40	GND	Ground	
41	SDIO_DATA3_SPI_CS	<p>SDIO 4-bit Mode: Data line 3 SDIO 1-bit Mode: Not used This pin has an internal weak pull-up resistor. The resistor is enabled by default but can be disabled by software. The value of the pull-up depends on the VDDIO_SD supply voltage. For 1.8V, the resistance range is 30–82 k Ohms. For 2.6V, it ranges from 21–41 k Ohms. For 3.3V, it ranges from 15–35 k ohms</p>	I/O
42	WL_SHUTDOWN_N	Low asserting reset for WLAN core.	I
43	SDIO_DATA1_SPI_IRQ	<p>SDIO 4-bit Mode: Data line 1 or Interrupt SDIO 1-bit Mode: Interrupt This pin has an internal weak pull-up resistor. The resistor is enabled by default but can be disabled by software. The value of the pull-up depends on the VDDIO_SD supply voltage. For 1.8V, the resistance range is 30–82 k Ohms. For 2.6V, it ranges from 21–41 k Ohms. For 3.3V, it ranges from 15–35 k ohms.</p>	I/O

Pin No	Pin Name	Description	Type
44	WL_GPIO_1	Reserved pin. WLAN general purpose interface pins. The pin is high-impedance on power up and reset. Subsequently, they become inputs or outputs through software control. The pin has programmable pull-up/down.	
45	SDIO_CMD_SPI_DI	SDIO 4-bit Mode: Command line SDIO 1-bit Mode: Command line This pin has an internal weak pull-up resistor. The resistor is enabled by default but can be disabled by software. The value of the pull-up depends on the VDDIO_SD supply voltage. For 1.8V, the resistance range is 30–82 k Ohms. For 2.6V, it ranges from 21–41 k Ohms. For 3.3V, it ranges from 15–35 k ohms	I/O
46	BT_GPIO_2	Reserved pin. Bluetooth general purpose interface pin. The pin is high-impedance on power up and reset. Subsequently, they become inputs or outputs through software control.	
47	SDIO_DATA0_SPI_DO	SDIO 4-bit Mode: Data line 0 SDIO 1-bit Mode: Data line This pin has an internal weak pull-up resistor. The resistor is enabled by default but can be disabled by software. The value of the pull-up depends on the VDDIO_SD supply voltage. For 1.8V, the resistance range is 30–82 k Ohms. For 2.6V, it ranges from 21–41 k Ohms. For 3.3V, it ranges from 15–35 k ohms	I/O
48	VDDIO_SD	SDIO/SPI I/O supply (1.8V ~ 3.3V)	I
49	BT_SHUTDOWN_N	Used by PMU (along with WL_SHUTDOWN_N_RST_N) to decide whether or not to power down internal BCM4329 regulators. If both BT_SHUTDOWN_N and WL_SHUTDOWN_N_RST_N are low then the regulators will be disabled. This signal has an internal 200 k ohms pull-down resistor. The minimum Vih for this pin is 1.36V; the maximum is 3.3V ± 10%.	I
50	GND	Ground	
51	RTC_CLK	Real Time Clock 32.768KHz input (Auto-detection of frequencies requires that the RTC_CLK frequency drift < 200 ppm.	I
52	NC	No Connect	

※ All of pin definition for module side

AZUREWAVE

Inspired by wireless

Confidential

- Warning!! This is a message from Azurewave and the information you are viewing now is strictly confidential and is a knowledge property to Azurewave.
- Unauthorized use of this document is prohibited and Azurewave retains the right for legal actions against any loss suffered or expenditure due to the misuse of any information form this document.

3-2. Pin Description comparison with PCI-Express specification

※ All of pin definition for module side

	PCI-Express Definition	AW-NH930 Definition		PCI-Express Definition	AW-NH930 Definition
Pin No	Name	Name	Pin No	Name	Name
1	WAKE#	WL_HOST_WAKE	2	3.3Vaux	VBAT3V3_IN
3	Reserved	BT_PCM_IN	4	GND	GND
5	Reserved	BT_PCM_OUT	6	1.5V	N/A
7	CLKREQ#	BT_HOST_WAKE	8	Reserved	BT_UART_CTS_N
9	GND	GND	10	Reserved	BT_UART_TXD
11	RFCLK-	FM_AUDIO_L	12	Reserved	BT_UART_RXD
13	RFCLK+	FM_AUDIO_R	14	Reserved	BT_UART_RTS_N
15	GND	GND	16	Reserved	BT_WAKE
17	Reserved	BT_PCM_SYNC	18	GND	GND
19	Reserved	BT_PCM_CLK	20	Reserved	BT_RST_N
21	GND	GND	22	PERST#	WL_RST_N
23	PERn0	N/A	24	3.3Vaux	VBAT3V3_IN
25	PERp0	N/A	26	GND	GND
27	GND	GND	28	1.5V	VDDIO
29	GND	GND	30	SMB_CLK	N/A
31	PETn0	N/A	32	SMB_DATA	N/A
33	PETp0	N/A	34	GND	GND
35	GND	GND	36	USB_D-	N/A
37	Reserved	SDIO_DATA2_SPI_NC	38	USB_D+	N/A
39	Reserved	SDIO_CLK_SPI_CLK	40	GND	GND
41	Reserved	SDIO_DATA3_SPI_CS	42	LED_WWAN#	WL_SHUTDOWN_N
43	Reserved	SDIO_DATA1_SPI_IRQ	44	LED_WLAN#	WL_GPIO_1
45	Reserved	SDIO_CMD_SPI_DI	46	LED_WPAN#	BT_GPIO_2
47	Reserved	SDIO_DATA0_SPI_DO	48	1.5V	VDDIO_SD
49	Reserved	BT_SHUTDOWN_N	50	GND	GND
51	Reserved	RTC_CLK	52	3.3Vaux	N/A

Federal Communication Commission Interference Statement

This equipment has been tested and found to comply with the limits for a Class B digital device, pursuant to Part 15 of the FCC Rules. These limits are designed to provide reasonable protection against harmful interference in a residential installation. This equipment generates, uses and can radiate radio frequency energy and, if not installed and used in accordance with the instructions, may cause harmful interference to radio communications. However, there is no guarantee that interference will not occur in a particular installation. If this equipment does cause harmful interference to radio or television reception, which can be determined by turning the equipment off and on, the user is encouraged to try to correct the interference by one of the following measures:

- Reorient or relocate the receiving antenna.
- Increase the separation between the equipment and receiver.
- Connect the equipment into an outlet on a circuit different from that to which the receiver is connected.
- Consult the dealer or an experienced radio/TV technician for help.

FCC Caution: Any changes or modifications not expressly approved by the party responsible for compliance could void the user's authority to operate this equipment.

This device complies with Part 15 of the FCC Rules. Operation is subject to the following two conditions: (1) This device may not cause harmful interference, and (2) this device must accept any interference received, including interference that may cause undesired operation.

IMPORTANT NOTE:

FCC Radiation Exposure Statement:

This equipment complies with FCC radiation exposure limits set forth for an uncontrolled environment. This equipment should be installed and operated with minimum distance 20cm between the radiator & your body. This transmitter must not be co-located or operating in conjunction with any other antenna or transmitter.

Operations in the 5.15-5.25GHz band are restricted to indoor usage only.

This device is intended only for OEM integrators under the following conditions:

- 1) The antenna must be installed such that 20 cm is maintained between the antenna and users, and
 - 2) The transmitter module may not be co-located with any other transmitter or antenna,
 - 3) For all products market in US, OEM has to limit the operation channels in CH1 to CH11 for 2.4G band by supplied firmware programming tool. OEM shall not supply any tool or info to the end-user regarding to Regulatory Domain change.
- As long as 3 conditions above are met, further transmitter test will not be required. However, the OEM integrator is still responsible for testing their end-product for any additional compliance requirements required with this module installed

IMPORTANT NOTE: In the event that these conditions can not be met (for example certain laptop configurations or co-location with another transmitter), then the FCC authorization is no longer considered valid and the FCC ID can not be used on the final product. In these circumstances, the OEM integrator will be responsible for re-evaluating the end product (including the transmitter) and obtaining a separate FCC authorization.

End Product Labeling

This transmitter module is authorized only for use in device where the antenna may be installed such that 20 cm may be maintained between the antenna and users. The final end product must be labeled in a visible area with the following: "Contains FCC ID: TLZ-NH930".

Manual Information To the End User

The OEM integrator has to be aware not to provide information to the end user regarding how to install or remove this RF module in the user's manual of the end product which integrates this module. The end user manual shall include all required regulatory information/warning as show in this manual.

5. Antenna port Information

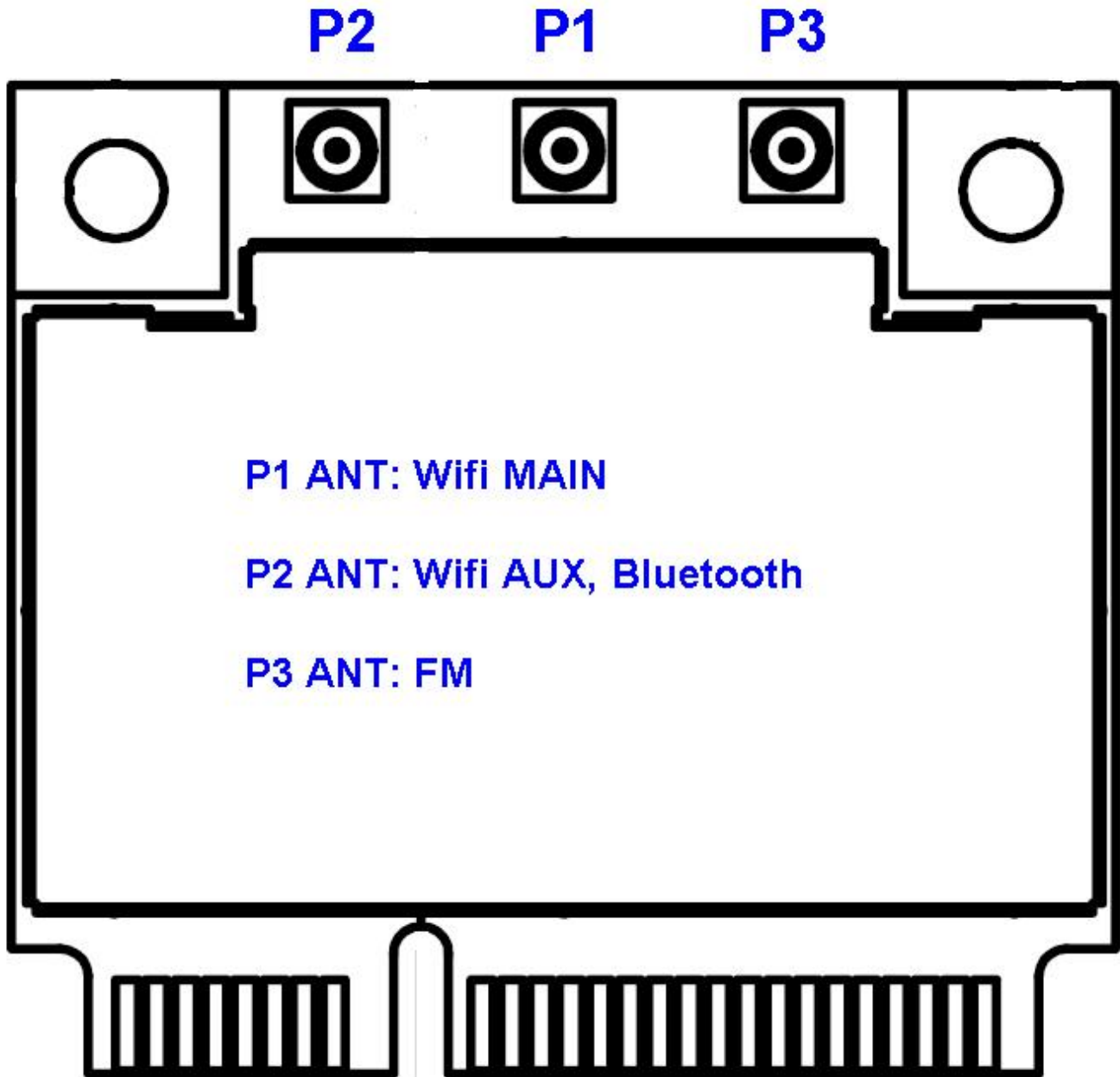

HA