



FCC TEST REPORT (Bluetooth)

REPORT NO.: RF991223E06B-1

MODEL NO.: AW-NH930

FCC ID: TLZ-NH930

RECEIVED: Dec. 23, 2010

TESTED: Jan. 26 to Feb. 08, 2011

ISSUED: Apr. 08, 2011

APPLICANT: AzureWave Technologies, Inc.

ADDRESS: 8 F., No. 94, Baozhong Rd., Xindian, Taipei, Taiwan
231

ISSUED BY: Bureau Veritas Consumer Products Services (H.K.)
Ltd., Taoyuan Branch Hsin Chu Laboratory

LAB ADDRESS: No. 81-1, Lu Liao Keng, 9th Ling, Wu Lung Tsuen,
Chiung Lin Hsiang, Hsin Chu Hsien 307, Taiwan

TEST LOCATION (1): No. 81-1, Lu Liao Keng, 9th Ling, Wu Lung Tsuen,
Chiung Lin Hsiang, Hsin Chu Hsien 307, Taiwan

TEST LOCATION (2): No.49, Ln. 206, Wende Rd., Shangshan Tsuen,
Chiung Lin Hsiang, Hsin Chu Hsien 307, Taiwan

This test report consists of 76 pages in total. It may be duplicated completely for legal use with the approval of the applicant. It should not be reproduced except in full, without the written approval of our laboratory. The client should not use it to claim product certification, approval, or endorsement by TAF or any government agencies. The test results in the report only apply to the tested sample.





TABLE OF CONTENTS

RELEASE CONTROL RECORD	4
1 CERTIFICATION	5
2 SUMMARY OF TEST RESULTS.....	6
2.1 MEASUREMENT UNCERTAINTY	7
3 GENERAL INFORMATION	8
3.1 GENERAL DESCRIPTION OF EUT.....	8
3.2 DESCRIPTION OF TEST MODES.....	10
3.3 TEST MODE APPLICABILITY AND TESTED CHANNEL DETAIL:	11
3.4 GENERAL DESCRIPTION OF APPLIED STANDARDS	12
3.5 DESCRIPTION OF SUPPORT UNITS	13
3.6 CONFIGURATION OF SYSTEM UNDER TEST.....	13
4 TEST PROCEDURES AND RESULTS	14
4.1 CONDUCTED EMISSION MEASUREMENT	14
4.1.1 LIMITS OF CONDUCTED EMISSION MEASUREMENT.....	14
4.1.2 TEST INSTRUMENTS.....	14
4.1.3 TEST PROCEDURES	15
4.1.4 TEST SETUP	15
4.1.5 EUT OPERATING CONDITIONS.....	16
4.1.6 TEST RESULTS	17
4.2 NUMBER OF HOPPING FREQUENCY USED	19
4.2.1 LIMIT OF HOPPING FREQUENCY USED.....	19
4.2.2 TEST INSTRUMENTS.....	19
4.2.3 TEST PROCEDURES	19
4.2.4 DEVIATION FROM TEST STANDARD	19
4.2.5 TEST SETUP	20
4.2.6 TEST RESULTS.....	20
4.3 DWELL TIME ON EACH CHANNEL	24
4.3.1 LIMIT OF DWELL TIME USED	24
4.3.2 TEST INSTRUMENTS.....	24
4.3.3 TEST PROCEDURES	24
4.3.4 DEVIATION FROM TEST STANDARD	25
4.3.5 TEST SETUP	25
4.3.6 TEST RESULTS.....	25
4.4 CHANNEL BANDWIDTH	37
4.4.1 LIMITS OF CHANNEL BANDWIDTH.....	37
4.4.2 TEST INSTRUMENTS.....	37
4.4.3 TEST PROCEDURE.....	37
4.4.4 DEVIATION FROM TEST STANDARD	37
4.4.5 TEST SETUP	38
4.4.6 EUT OPERATING CONDITION	38
4.4.7 TEST RESULTS.....	39
4.5 HOPPING CHANNEL SEPARATION	42
4.5.1 LIMIT OF HOPPING CHANNEL SEPARATION.....	42
4.5.2 TEST INSTRUMENTS.....	42
4.5.3 TEST PROCEDURES	42



A D T

4.5.4	DEVIATION FROM TEST STANDARD	42
4.5.5	TEST SETUP	42
4.5.6	TEST RESULTS	43
4.6	MAXIMUM PEAK OUTPUT POWER	49
4.6.1	LIMITS OF MAXIMUM PEAK OUTPUT POWER MEASUREMENT	49
4.6.2	INSTRUMENTS	49
4.6.3	TEST PROCEDURES	49
4.6.4	DEVIATION FROM TEST STANDARD	49
4.6.5	TEST SETUP	50
4.6.6	EUT OPERATING CONDITION	50
4.6.7	TEST RESULTS	51
4.7	RADIATED EMISSION MEASUREMENT	54
4.7.1	LIMITS OF RADIATED EMISSION MEASUREMENT	54
4.7.2	TEST INSTRUMENTS.....	55
4.7.3	TEST PROCEDURES	57
4.7.4	DEVIATION FROM TEST STANDARD	57
4.7.5	TEST SETUP	58
4.7.6	EUT OPERATING CONDITIONS.....	58
4.7.7	TEST RESULTS	59
4.8	CONDUCTED OUT-BAND EMISSION MEASUREMENT.....	70
4.8.1	LIMITS OF CONDUCTED OUT-BAND EMISSION MEASUREMENT.....	70
4.8.2	TEST INSTRUMENTS.....	70
4.8.3	TEST PROCEDURE.....	70
4.8.4	DEVIATION FROM TEST STANDARD	70
4.8.5	EUT OPERATING CONDITION	70
4.8.6	TEST RESULTS	71
5	INFORMATION ON THE TESTING LABORATORIES	75
6	APPENDIX A - MODIFICATIONS RECORDERS FOR ENGINEERING CHANGES TO THE EUT BY THE LAB.....	76



A D T

RELEASE CONTROL RECORD

ISSUE NO.	REASON FOR CHANGE	DATE ISSUED
Original release	NA	Apr. 08, 2011



1 CERTIFICATION

PRODUCT : IEEE 802.11 a/b/g/n Wireless LAN, Bluetooth and FM Combo Half Mini Card

BRAND NAME : AzureWave

MODEL NO. : AW-NH930

APPLICANT : AzureWave Technologies, Inc.

TESTED DATE : Jan. 26 to Feb. 08, 2011

TEST SAMPLE : ENGINEERING SAMPLE

STANDARDS : FCC Part 15, Subpart C (Section 15.247)
ANSI C63.4-2003
ANSI C63.10-2009

The above equipment (Model: AW-NH930) has been tested by **Bureau Veritas Consumer Products Services (H.K.) Ltd., Taoyuan Branch**, and found compliance with the requirement of the above standards. The test record, data evaluation & Equipment Under Test (EUT) configurations represented herein are true and accurate accounts of the measurements of the sample's EMC characteristics under the conditions specified in this report.

PREPARED BY :  , **DATE:** Apr. 08, 2011
(Claire Kaun, Specialist)

APPROVED BY :  , **DATE:** Apr. 08, 2011
(May Chen, Deputy Manager)



2 SUMMARY OF TEST RESULTS

The EUT has been tested according to the following specifications:

APPLIED STANDARD: FCC Part 15, Subpart C			
Standard Section	Test Type and Limit	Result	REMARK
15.207	AC Power Conducted Emission	PASS	Meet the requirement of limit Minimum passing margin is -25.59dB at 3.391MHz
15.247(a)(1)(I)-(ii)	Number of Hopping Frequency Used Spec.: At least 15 channels	PASS	Meet the requirement of limit
15.247(a)(1)(ii)	Dwell Time on Each Channel Spec.: Max. 0.4 second within 31.6 second	PASS	Meet the requirement of limit
15.247(a)(1)(I)-(ii)	Hopping Channel Separation Spec. : Min. 25 kHz or two-thirds of 20 dB bandwidth, which ever is greater	PASS	Meet the requirement of limit
15.247(a)(2)	Spectrum Bandwidth of a Frequency Hopping Sequence Spread Spectrum System	PASS	Meet the requirement of limit
15.247(b)	Maximum Peak Output Power Spec.: max. 125mW	PASS	Meet the requirement of limit
15.247(c)	Transmitter Radiated Emissions Spec.: Table 15.209	PASS	Meet the requirement of limit Minimum passing margin is -1.0dB at 108.06MHz
15.247(c)	Conducted Out-Band Emissions Measurement	PASS	Meet the requirement of limit
15.203	Antenna Requirement	PASS	Antenna connector is I-PEX connector.

2.1 MEASUREMENT UNCERTAINTY

Where relevant, the following measurement uncertainty levels have been estimated for tests performed on the EUT as specified in CISPR 16-4-2:

This uncertainty represents an expanded uncertainty expressed at approximately the 95% confidence level using a coverage factor of $k=2$.

Measurement	Value
Conducted emissions	2.45 dB
Radiated emissions (30MHz-1GHz) – Chamber H	3.76 dB
Radiated emissions (1GHz -18GHz) –Chamber G	2.19 dB
Radiated emissions (18GHz -40GHz) –Chamber G	2.56 dB



3 GENERAL INFORMATION

3.1 GENERAL DESCRIPTION OF EUT

PRODUCT	IEEE 802.11 a/b/g/n Wireless LAN, Bluetooth and FM Combo Half Mini Card
MODEL NO.	AW-NH930
FCC ID	TLZ-NH930
POWER SUPPLY	DC 1.8-3.3V from host equipment DC 2.3-5.5V from internal PMU
MODULATION TYPE	GFSK, $\pi/4$ -DQPSK, 8DPSK
MODULATION TECHNOLOGY	FHSS
TRANSFER RATE	1M (DH1, DH3, DH5), 2M (2DH1, 2DH3, 2DH5), 3M (3DH1,3DH3, 3DH5)
FREQUENCY RANGE	2402MHz ~ 2480MHz
NUMBER OF CHANNEL	79
CHANNEL SPACING	1 MHz
MAXIMUM OUTPUT POWER	GFSK: 7.4 mW $\pi/4$ – DQPSK: 11.5 mW 8DPSK: 7.6 mW
ANTENNA TYPE	Please see note
DATA CABLE	NA
I/O PORTS	NA
ASSOCIATED DEVICES	NA

NOTE:

1. There are Bluetooth technology (Bluetooth 2.1+Enhanced Data Rate (EDR) / BT3.0+HS), WLAN and FM technology used for the EUT:

Technology	Report No.
WLAN(FCC 15.247)	RF991223E06B
Bluetooth	RF991223E06B-1
WLAN(FCC 15.407)	RF991223E06B-2
DFS	RF991223E06B-3

2. Spurious emission of the simultaneous operation (WLAN & Bluetooth) has been evaluated and no non-compliance found.



3. The below antennas provided to this EUT, please refer to the following table:

No.	Brand	Model No.	Gain (dBi) Include cable loss	Antenna Type	Connector Type	Frequency Range (MHz to MHz)	Cable Loss (dB)	Cable Length (cm)
1	MAGLAYERS	MSA-4008-25GC1-A1	2.98 5.16	PIFA	I-PEX	2400~2483.5 4900~5900	0.6 1	15
2	MAGLAYERS	MSA-3305-2G4C1-A1	2.28	PIFA	I-PEX	2400~2483.5	0.6	4
3	INPAQ	WA-P-LA-02-019	2.3	PIFA	I-PEX	2400~2483.5	0.24	6
4	INPAQ	EAMS13001	1.05	PIFA	I-PEX	2400~2483.5	1.3	31.6
5	WNC	81XCAE15.G07	-2.5	PIFA	I-PEX	2400~2483.5	4	61.5
6	WNC	NA	1.67	PIFA	I-PEX	2400~2483.5	4.5	69.4
7	Etertronics Inc.	6036B0067403	0.26 2.07	PIFA	I-PEX	2400~2483.5 4900~5900	0.81 1.17	36.7
8	Walsin Tech.Corp	RFPCA2207101FABE01	1.39	PIFA	I-PEX	2400~2483.5	0.5	10
9	Anden	150872-30	1.25	PIFA	I-PEX	2400~2483.5	0.4	6.2
10	Whayu	C1335-520058-A	-1.68	PIFA	I-PEX	2400~2483.5	1.29	19.5
11	Whayu	C1335-520059-A	0.65	PIFA	I-PEX	2400~2483.5	1.43	8.0

From the above antennas, **Antenna 1** was selected as representative antenna for the test and its data was recorded in this report.

4. The EUT was pre-tested under the following test modes for three different axes placements:

Test Mode	Description
Mode A	X-Z plane
Mode B	X-Y plane
Mode C	Y-Z plane

From the above modes, the radiated emission worst case was found in Mode B. Therefore only the test data of the modes were recorded in this report.

5. The EUT incorporates a SISO function with 802.11n.
6. The EUT is 1 * 1 spatial SISO without beam forming function.
7. The EUT, operates in the 2.4GHz frequency range, lets you connect IEEE 802.11g or IEEE 802.11b and 802.11n technique devices to the network.
8. The above EUT information was declared by manufacturer and for more detailed features description, please refer to the manufacturer's specifications or user's manual.



3.2 DESCRIPTION OF TEST MODES

Seventy-nine channels are provided to this EUT.

Channel	Freq. (MHz)	Channel	Freq. (MHz)	Channel	Freq. (MHz)	Channel	Freq. (MHz)
0	2402	20	2422	40	2442	60	2462
1	2403	21	2423	41	2443	61	2463
2	2404	22	2424	42	2444	62	2464
3	2405	23	2425	43	2445	63	2465
4	2406	24	2426	44	2446	64	2466
5	2407	25	2427	45	2447	65	2467
6	2408	26	2428	46	2448	66	2468
7	2409	27	2429	47	2449	67	2469
8	2410	28	2430	48	2450	68	2470
9	2411	29	2431	49	2451	69	2471
10	2412	30	2432	50	2452	70	2472
11	2413	31	2433	51	2453	71	2473
12	2414	32	2434	52	2454	72	2474
13	2415	33	2435	53	2455	73	2475
14	2416	34	2436	54	2456	74	2476
15	2417	35	2437	55	2457	75	2477
16	2418	36	2438	56	2458	76	2478
17	2419	37	2439	57	2459	77	2479
18	2420	38	2440	58	2460	78	2480
19	2421	39	2441	59	2461		



3.3 TEST MODE APPLICABILITY AND TESTED CHANNEL DETAIL:

EUT CONFIGURE MODE	APPLICABLE TO				DESCRIPTION
	PLC	RE < 1G	RE ≥ 1G	APCM	
-	√	√	√	√	-

Where **PLC**: Power Line Conducted Emission **RE < 1G**: Radiated Emission below 1GHz
RE ≥ 1G: Radiated Emission above 1GHz **APCM**: Antenna Port Conducted Measurement

ANTENNA COMBINATION MODE:

COMBINATION MODE	OPERATION MODE	TX CHAIN (P1)	TX CHAIN (P2)
A	Bluetooth		√

Note:
1. The above information was declared by manufacturer and for more detailed features description, please refer to the manufacturer's specifications or user's manual.

Power Line Conducted Emission Test:

- Pre-Scan has been conducted to determine the worst-case mode from all possible combinations between available modulations, data rates and antenna ports (if EUT with antenna diversity architecture).
- Following channel(s) was (were) selected for the final test as listed below.

Available Channel	Tested Channel	Modulation Technology	Modulation Type	Packet Type	CONFIGURE MODE
0 to 78	78	FHSS	$\pi/4$ -DQPSK	DH5	-

Radiated Emission Test (Below 1 GHz):

- Pre-Scan has been conducted to determine the worst-case mode from all possible combinations between available modulations, data rates and antenna ports (if EUT with antenna diversity architecture).
- Following channel(s) was (were) selected for the final test as listed below.

Available Channel	Tested Channel	Modulation Technology	Modulation Type	Packet Type	CONFIGURE MODE
0 to 78	78	FHSS	$\pi/4$ -DQPSK	DH5	-

Radiated Emission Test (Above 1 GHz):

- Pre-Scan has been conducted to determine the worst-case mode from all possible combinations between available modulations, data rates and antenna ports (if EUT with antenna diversity architecture).
- Following channel(s) was (were) selected for the final test as listed below.

Available Channel	Tested Channel	Modulation Technology	Modulation Type	Packet Type	CONFIGURE MODE
0 to 78	0, 39, 78	FHSS	GFSK	DH5	-
0 to 78	0, 39, 78	FHSS	8DPSK	DH5	-



A D T

Conducted Out-Band Emission Measurement:

- Pre-Scan has been conducted to determine the worst-case mode from all possible combinations between available modulations, data rates and antenna ports (if EUT with antenna diversity architecture).
- Following channel(s) was (were) selected for the final test as listed below.

Available Channel	Tested Channel	Modulation Technology	Modulation Type	Packet Type	CONFIGURE MODE
0 to 78	0, 78	FHSS	GFSK	DH5	-
0 to 78	0, 78	FHSS	8DPSK	DH5	-

Antenna Port Conducted Measurement:

- Pre-Scan has been conducted to determine the worst-case mode from all possible combinations between available modulations, data rates and antenna ports (if EUT with antenna diversity architecture).
- Following channel(s) was (were) selected for the final test as listed below.

Available Channel	Tested Channel	Modulation Technology	Modulation Type	Packet Type	CONFIGURE MODE
0 to 78	0, 39, 78	FHSS	GFSK	DH5	-
0 to 78	0, 39, 78	FHSS	$\pi/4$ -DQPSK	DH5	-
0 to 78	0, 39, 78	FHSS	8DPSK	DH5	-

TEST CONDITION:

APPLICABLE TO	ENVIRONMENTAL CONDITIONS	INPUT POWER (SYSTEM)	TESTED BY
RE ³ 1G	19deg. C, 68%RH, 1023 hPa	120Vac, 60Hz	Rex Huang
RE<1G	21deg. C, 68%RH, 1023 hPa	120Vac, 60Hz	Rex Huang
PLC	20deg. C, 60%RH, 1023 hPa	120Vac, 60Hz	Timmy Hu
APCM	15deg. C, 60%RH, 1023 hPa	120Vac, 60Hz	Rex Huang

3.4 GENERAL DESCRIPTION OF APPLIED STANDARDS

The EUT is a RF product. According to the specifications of the manufacturer, it must comply with the requirements of the following standards:

FCC Part 15, Subpart C. (15.247)

ANSI C63.4 : 2003

ANSI C63.10-2009

All test items have been performed and recorded as per the above standards.

NOTE: The EUT has been verified to comply with the requirements of FCC Part 15, Subpart B, Class B (DoC). The test report has been issued separately.



3.5 DESCRIPTION OF SUPPORT UNITS

The EUT has been tested as an independent unit together with other necessary accessories or support units. The following support units or accessories were used to form a representative test configuration during the tests.

No.	Product	Brand	Model No.	Serial No.	FCC ID
1	NOTEBOOK COMPUTER	DELL	PP32LA	DSL32S	FCC DoC
2	TEST TOOL	AzureWave	NA	NA	NA

No.	Signal cable description
1	NA
2	1.5m USB cable.

Note: The power cords of the above support units were unshielded (1.8m).

3.6 CONFIGURATION OF SYSTEM UNDER TEST

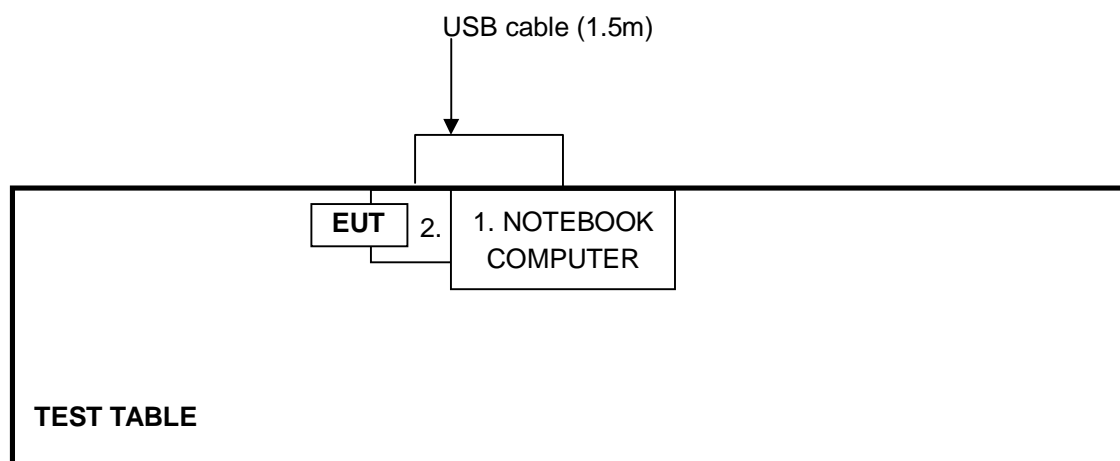

4 TEST PROCEDURES AND RESULTS

4.1 CONDUCTED EMISSION MEASUREMENT

4.1.1 LIMITS OF CONDUCTED EMISSION MEASUREMENT

FREQUENCY OF EMISSION (MHz)	CONDUCTED LIMIT (dB μ V)	
	Quasi-peak	Average
0.15-0.5	66 to 56	56 to 46
0.5-5	56	46
5-30	60	50

NOTE:

1. The lower limit shall apply at the transition frequencies.
2. All emanations from a class B digital device or system, including any network of conductors and apparatus connected thereto, shall not exceed the level of field strengths specified above.

4.1.2 TEST INSTRUMENTS

DESCRIPTION & MANUFACTURER	MODEL NO.	SERIAL NO.	CALIBRATED DATE	CALIBRATED UNTIL
Test Receiver	ESCS 30	100375	Mar. 09, 2010	Mar. 08, 2011
Line-Impedance Stabilization Network (for EUT)	NSLK 8127	8127-522	Sep. 08, 2010	Sep. 07, 2011
Line-Impedance Stabilization Network (for Peripheral)	ESH3-Z5	848773/004	Nov. 03, 2010	Nov. 02, 2011
RF Cable (JYEBAO)	5DFB	COCCAB-002	Aug. 30, 2010	Aug. 29, 2011
50 ohms Terminator	50	3	Nov. 03, 2010	Nov. 02, 2011
Software	BV ADT_Cond_V7.3.7	NA	NA	NA

Note:

1. The calibration interval of the above test instruments is 12 months and the calibrations are traceable to NML/ROC and NIST/USA.
2. The test was performed in Shielded Room No. C.
3. The VCCI Con C Registration No. is C-3611.

4.1.3 TEST PROCEDURES

- a. The EUT/HOST was placed 0.4 meters from the conducting wall of the shielded room with EUT/HOST being connected to the power mains through a line impedance stabilization network (LISN). Other support units were connected to the power mains through another LISN. The two LISNs provide 50 ohm/ 50uH of coupling impedance for the measuring instrument.
- b. Both lines of the power mains connected to the EUT/HOST were checked for maximum conducted interference.
- c. The frequency range from 150 kHz to 30 MHz was searched. Emission levels over 10dB under the prescribed limits could not be reported

4.1.4 TEST SETUP

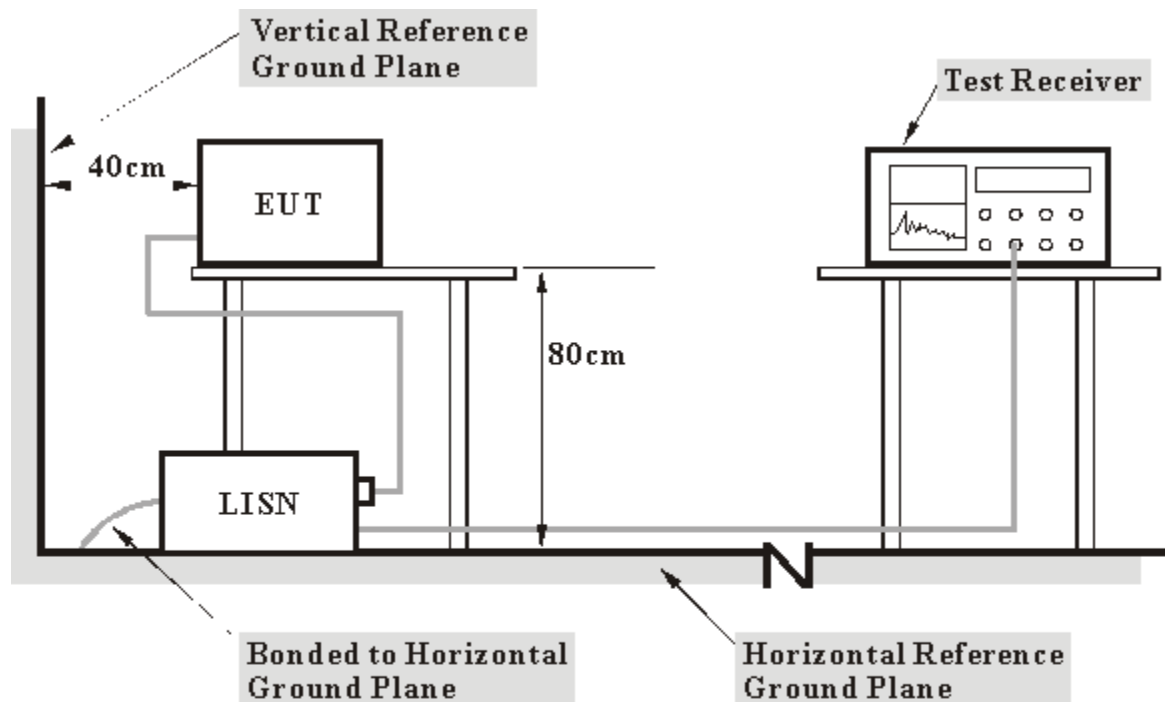

- Note:**
1. Support units were connected to second LISN.
 2. Both of LISNs (AMN) 80 cm from EUT and at the least 80 cm from other units and other metal planes support units.

For the actual test configuration, please refer to the related item – Photographs of the Test Configuration.

4.1.5 EUT OPERATING CONDITIONS

1. Connect the EUT with the support unit 1 (Notebook Computer) which is placed in test table.
2. The support unit 1 (Notebook Computer) runs test program “Broadcom Blue Tool v1.1.9.3” to enable EUT under transmission/receiving condition continuously at specific channel frequency.



A D T

4.1.6 TEST RESULTS

PHASE	Line (L)	6dB BANDWIDTH	9 kHz
-------	----------	---------------	-------

No	Freq. [MHz]	Corr. Factor (dB)	Reading Value		Emission Level		Limit		Margin	
			[dB (uV)]		[dB (uV)]		[dB (uV)]		(dB)	
			Q.P.	AV.	Q.P.	AV.	Q.P.	AV.	Q.P.	AV.
1	0.158	0.11	23.22	-	23.33	-	65.58	55.58	-42.25	-
2	0.927	0.14	24.48	-	24.62	-	56.00	46.00	-31.38	-
3	1.852	0.16	30.12	-	30.28	-	56.00	46.00	-25.72	-
4	3.391	0.19	30.22	-	30.41	-	56.00	46.00	-25.59	-
5	18.602	0.63	27.25	-	27.88	-	60.00	50.00	-32.12	-
6	26.352	0.87	23.46	-	24.33	-	60.00	50.00	-35.67	-

- REMARKS:**
1. Q.P. and AV. are abbreviations of quasi-peak and average individually.
 2. "-": The Quasi-peak reading value also meets average limit and measurement with the average detector is unnecessary.
 3. The emission levels of other frequencies were very low against the limit.
 4. Margin value = Emission level - Limit value
 5. Correction factor = Insertion loss + Cable loss
 6. Emission Level = Correction Factor + Reading Value.

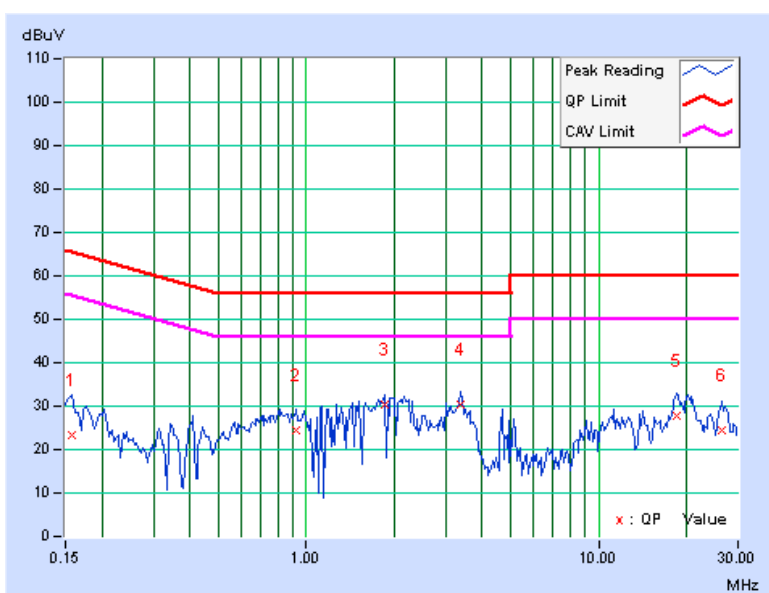



A D T

PHASE	Neutral (N)	6dB BANDWIDTH	9 kHz
--------------	-------------	----------------------	-------

No	Freq.	Corr.	Reading Value		Emission Level		Limit		Margin	
	[MHz]	Factor (dB)	[dB (uV)]		[dB (uV)]		[dB (uV)]		(dB)	
			Q.P.	AV.	Q.P.	AV.	Q.P.	AV.	Q.P.	AV.
1	0.228	0.14	21.98	-	22.12	-	62.52	52.52	-40.40	-
2	0.990	0.16	20.18	-	20.34	-	56.00	46.00	-35.66	-
3	1.785	0.18	27.31	-	27.49	-	56.00	46.00	-28.51	-
4	3.457	0.26	30.05	-	30.31	-	56.00	46.00	-25.69	-
5	18.477	1.33	26.76	-	28.09	-	60.00	50.00	-31.91	-
6	27.871	2.04	21.99	-	24.03	-	60.00	50.00	-35.97	-

- REMARKS:**
1. Q.P. and AV. are abbreviations of quasi-peak and average individually.
 2. "-": The Quasi-peak reading value also meets average limit and measurement with the average detector is unnecessary.
 3. The emission levels of other frequencies were very low against the limit.
 4. Margin value = Emission level - Limit value
 5. Correction factor = Insertion loss + Cable loss
 6. Emission Level = Correction Factor + Reading Value.

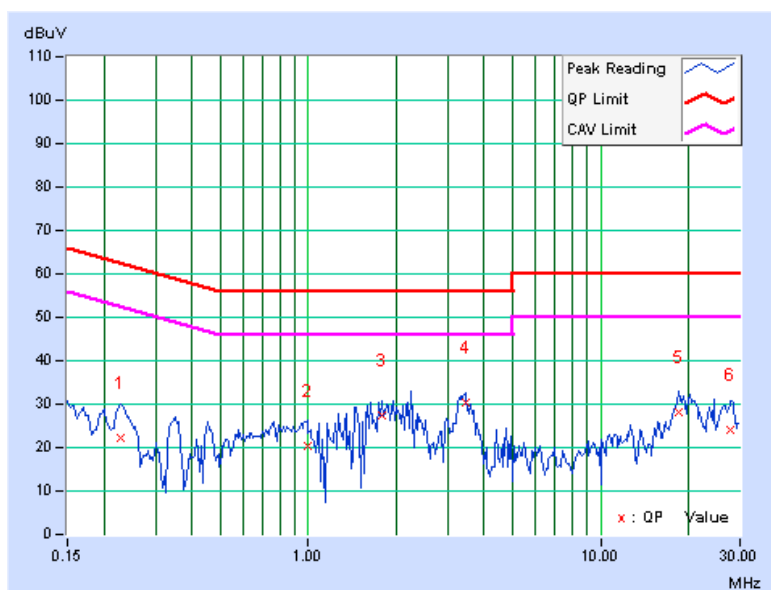

4.2 NUMBER OF HOPPING FREQUENCY USED

4.2.1 LIMIT OF HOPPING FREQUENCY USED

At least 15 hopping frequencies, and should be equally spaced.

4.2.2 TEST INSTRUMENTS

DESCRIPTION & MANUFACTURER	MODEL NO.	SERIAL NO.	CALIBRATED DATE	CALIBRATED UNTIL
PSA Seviess Spectrum Analyzer	FSP40	100036	Dec. 08, 2010	Dec. 07, 2011

NOTE:

1. The calibration interval of the above test instruments is 12 months and the calibrations are traceable to NML/ROC and NIST/USA.

4.2.3 TEST PROCEDURES

1. Check the calibration of the measuring instrument (SA) using either an internal calibrator or a known signal from an external generator.
2. Turn on the EUT and connect its antenna terminal to measurement via a low loss cable. Then set it to any one measured frequency within its operating range and make sure the instrument is operated in its linear range.
3. Set the SA on MaxHold Mode, and then keep the EUT in hopping mode. Record all the signals from each channel until each one has been recorded.
4. Set the SA on View mode and then plot the result on SA screen.
5. Repeat above procedures until all frequencies measured were complete.

4.2.4 DEVIATION FROM TEST STANDARD

No deviation

4.2.5 TEST SETUP

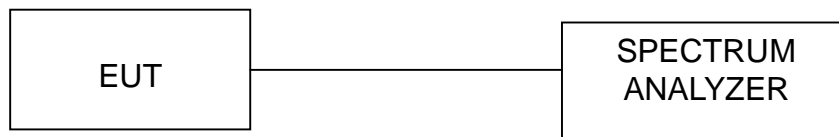

4.2.6 TEST RESULTS

There are 79 hopping frequencies in the hopping mode. Please refer to next pages for the test result. On the plots, it shows that the hopping frequencies are equally spaced.



A D T

For GFSK:

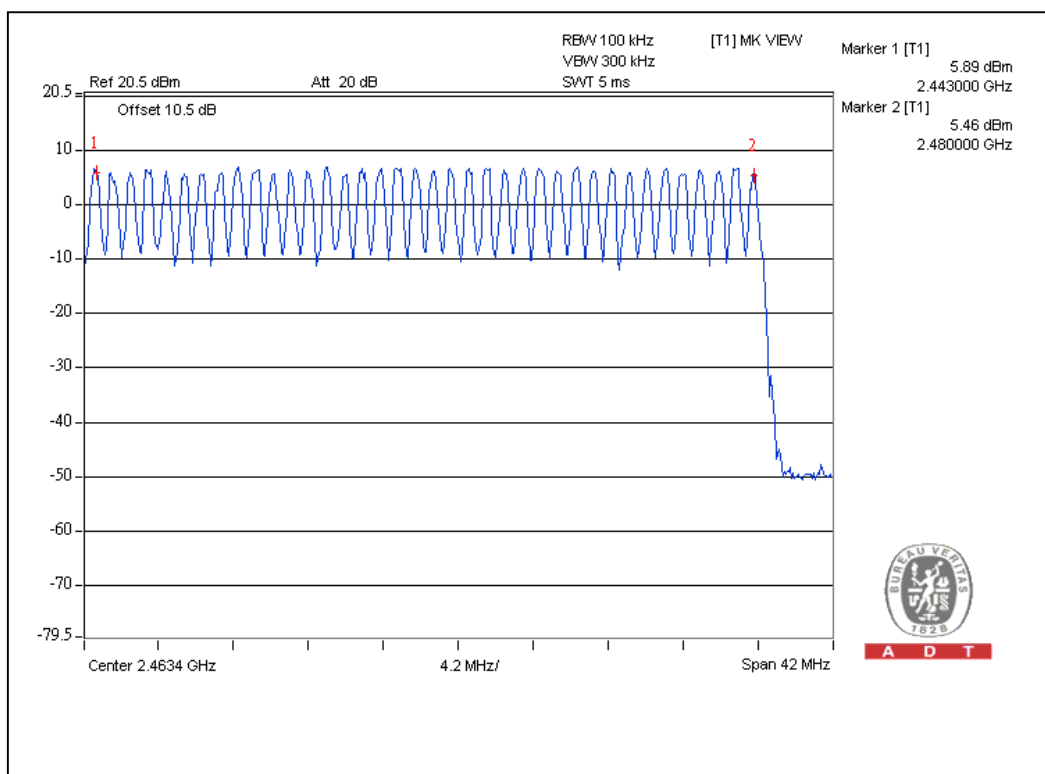
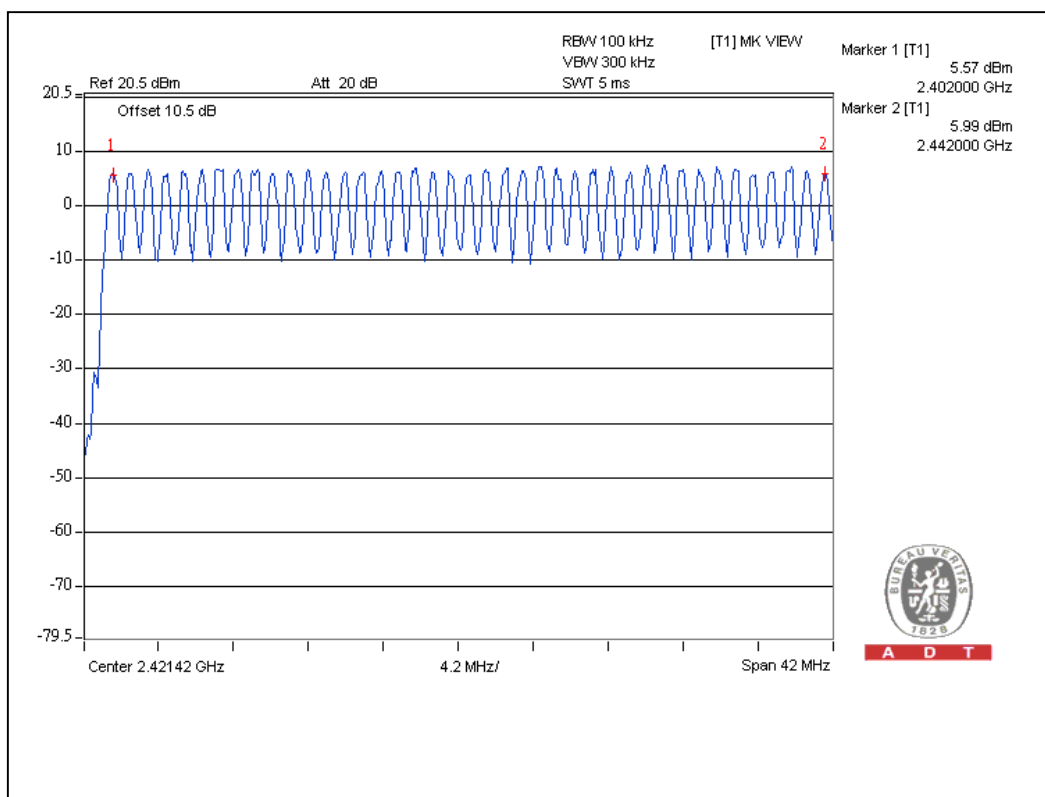



A D T

For $\pi/4$ -DQPSK :

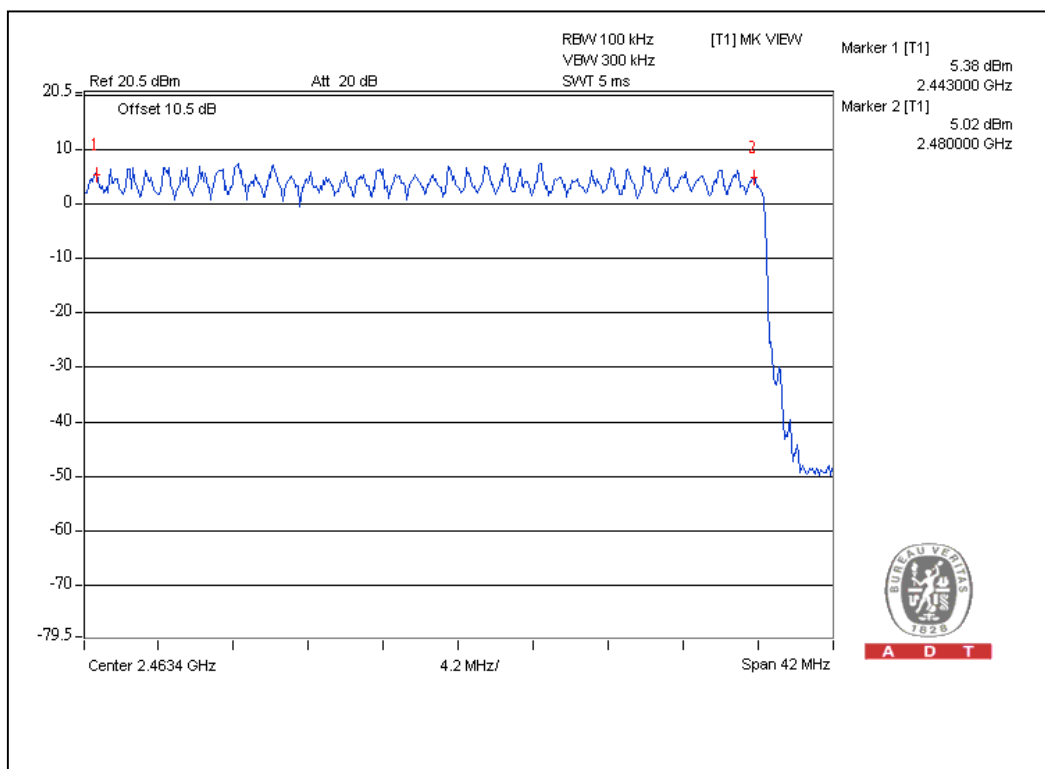
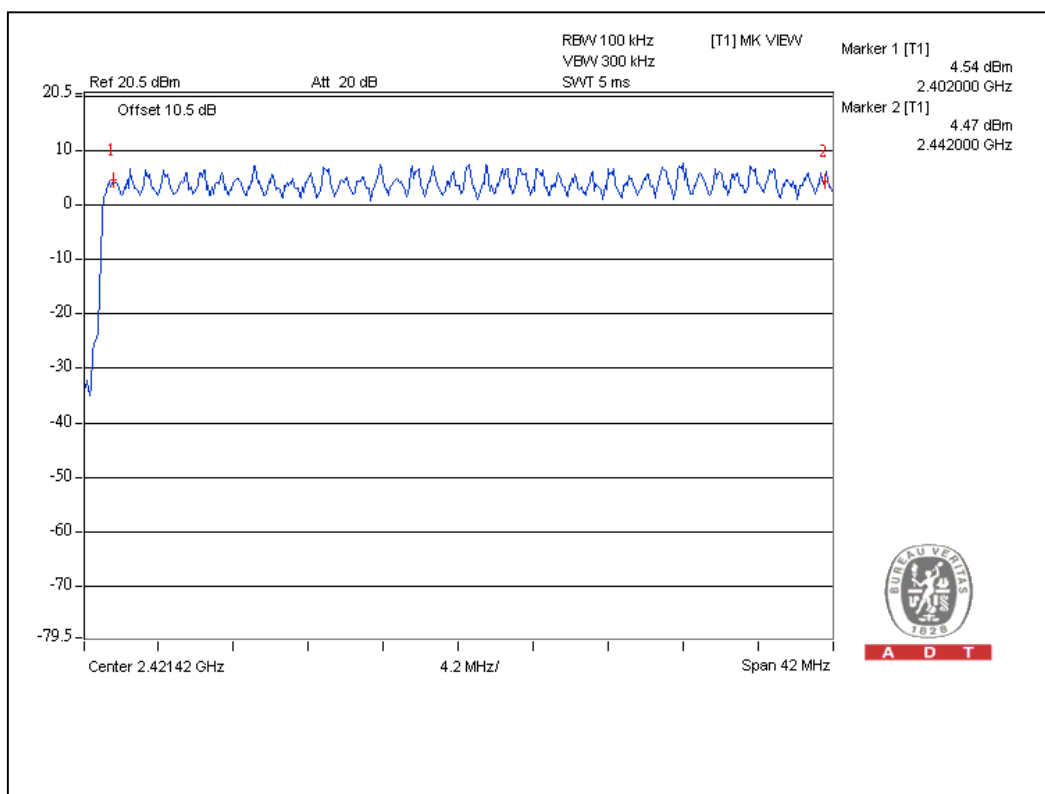



A D T

For 8DPSK:

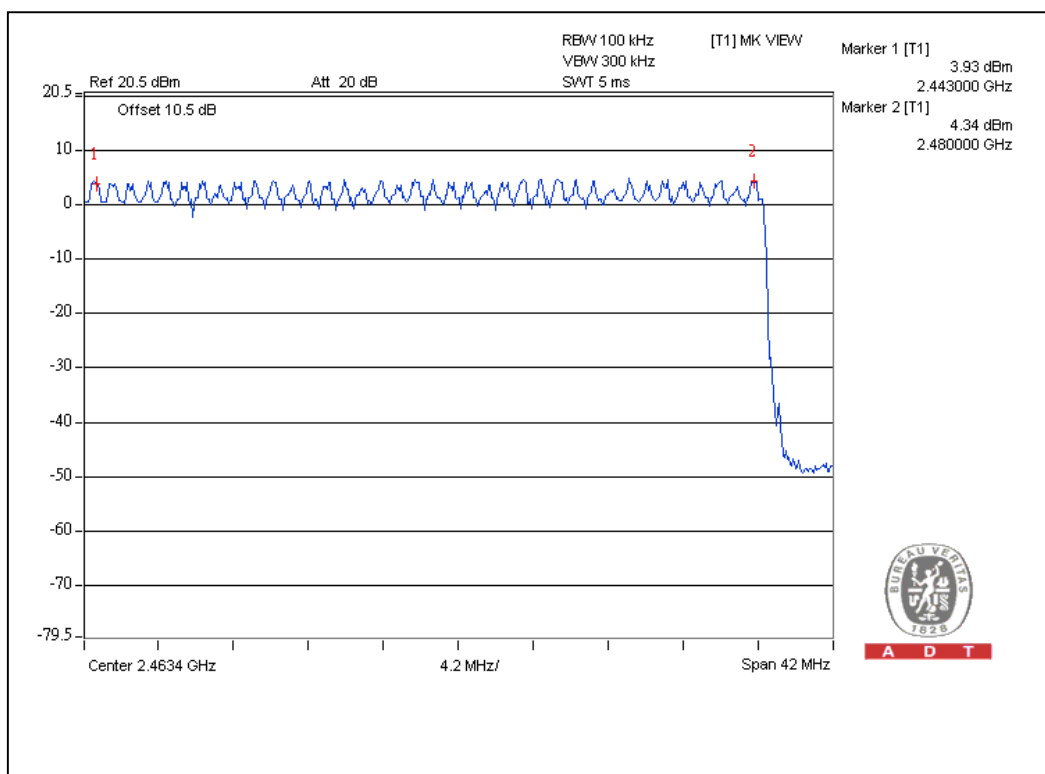
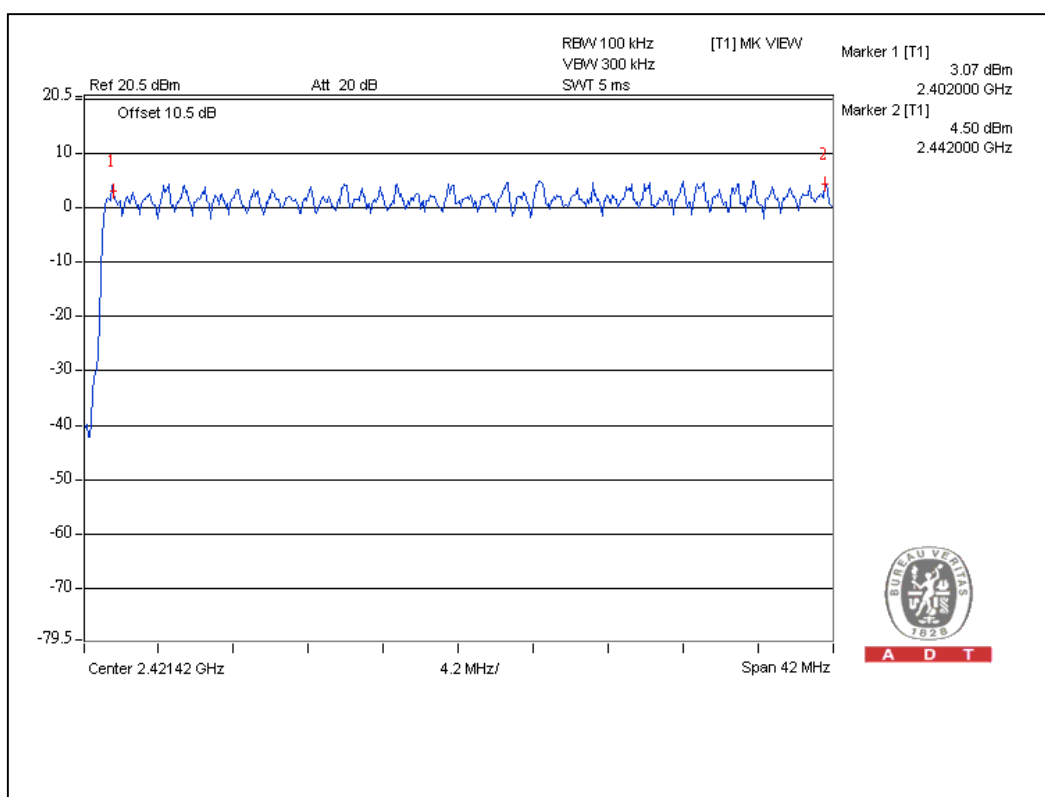

4.3 DWELL TIME ON EACH CHANNEL

4.3.1 LIMIT OF DWELL TIME USED

For FHSS, the average time of occupancy on any frequency shall not be greater than 0.4 seconds within a 31.6 second period. For hybrid systems, the average time of occupancy on any frequency should not exceed 0.4 seconds within a time period in seconds equal to the number of hopping frequencies employed multiplied by 0.4.

4.3.2 TEST INSTRUMENTS

DESCRIPTION & MANUFACTURER	MODEL NO.	SERIAL NO.	CALIBRATED DATE	CALIBRATED UNTIL
PSA Seviess Spectrum Analyzer	FSP40	100036	Dec. 08, 2010	Dec. 07, 2011

NOTE:

1. The calibration interval of the above test instruments is 12 months and the calibrations are traceable to NML/ROC and NIST/USA.

4.3.3 TEST PROCEDURES

1. Check the calibration of the measuring instrument (SA) using either an internal calibrator or a known signal from an external generator.
2. Turn on the EUT and connect its antenna terminal to measurement via a low loss cable. Then set it to any one measured frequency within its operating range and make sure the instrument is operated in its linear range.
3. Adjust the center frequency of SA on any frequency be measured and set SA to zero span mode. And then, set RBW and VBW of spectrum analyzer to proper value.
4. Measure the time duration of one transmission on the measured frequency. And then plot the result with time difference of this time duration.
5. Repeat above procedures until all frequencies measured were complete.

4.3.4 DEVIATION FROM TEST STANDARD

No deviation

4.3.5 TEST SETUP



4.3.6 TEST RESULTS

For GFSK:

Mode	Number of transmission in a 31.6 (79Hopping*0.4)	Length of transmission time (msec)	Result (msec)	Limit (msec)
DH1	47 (times / 5 sec) *6.32=297.04 times	0.534	158.6	400
DH3	26 (times / 5 sec) *6.32=164.32 times	1.776	291.8	400
DH5	18 (times / 5 sec) *6.32=113.76 times	3.03	344.7	400

Test plots of the transmitting time slot are shown on next three pages.



A D T

DH1

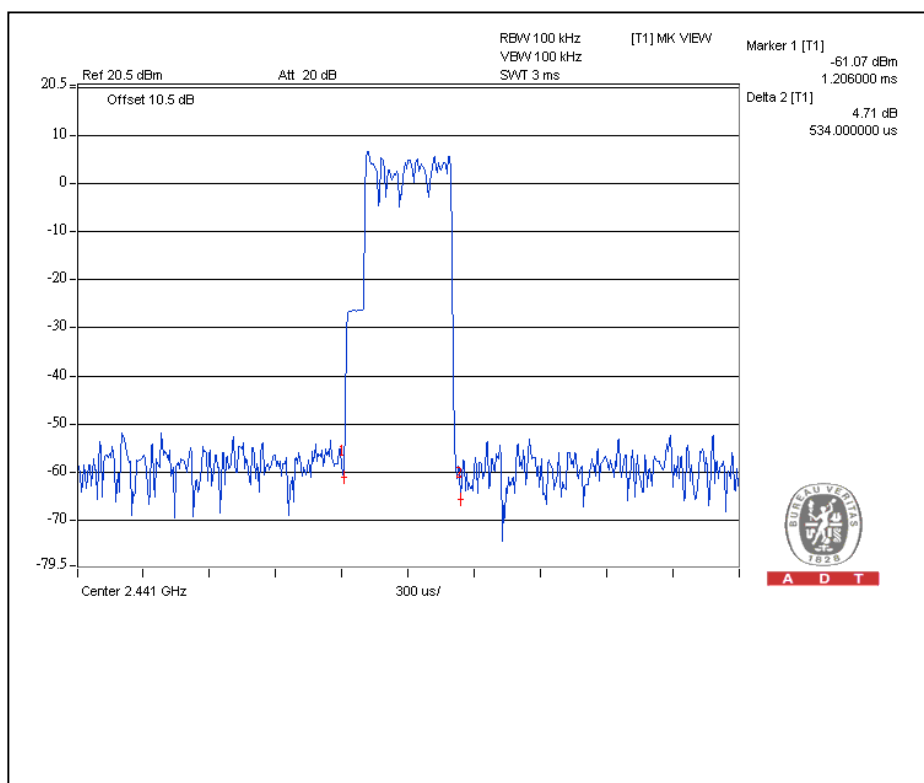
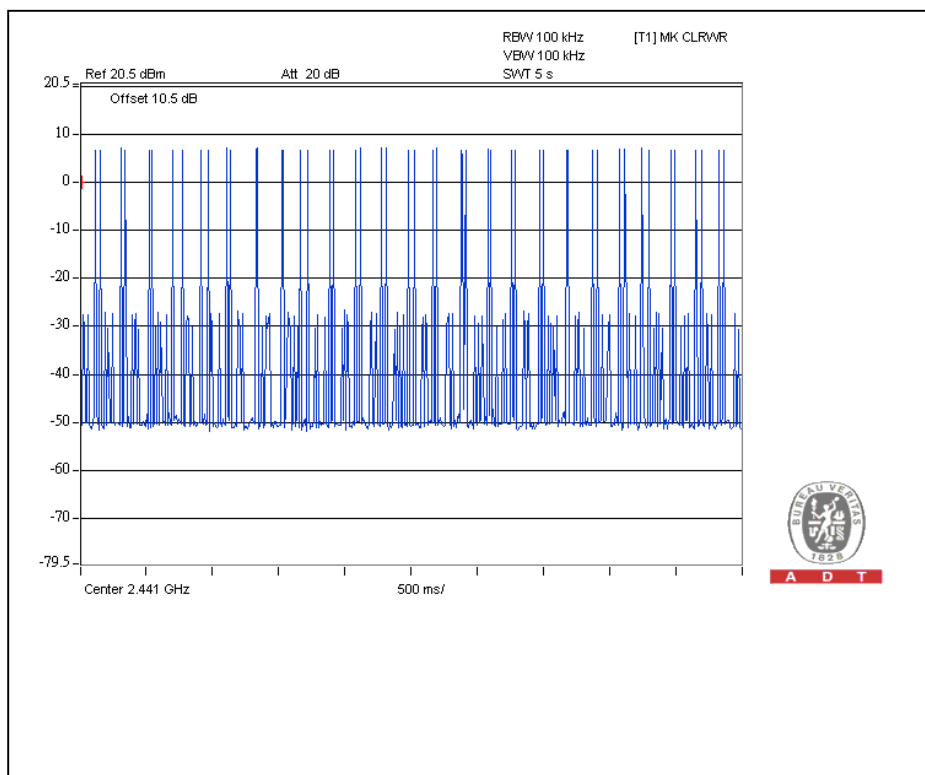



A D T

DH3

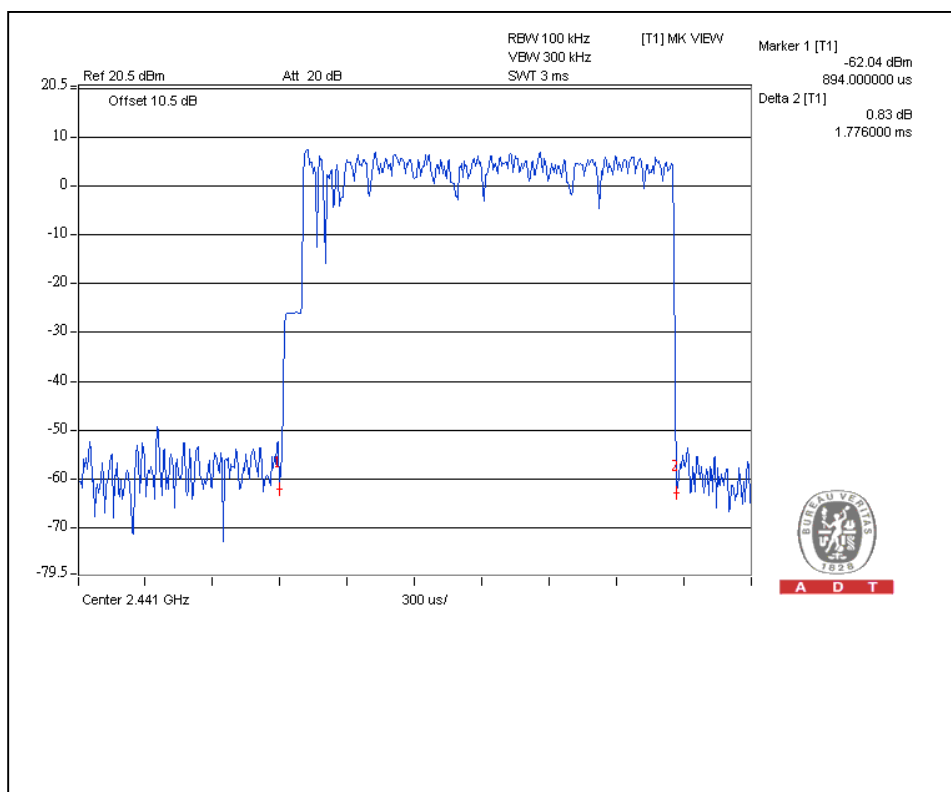
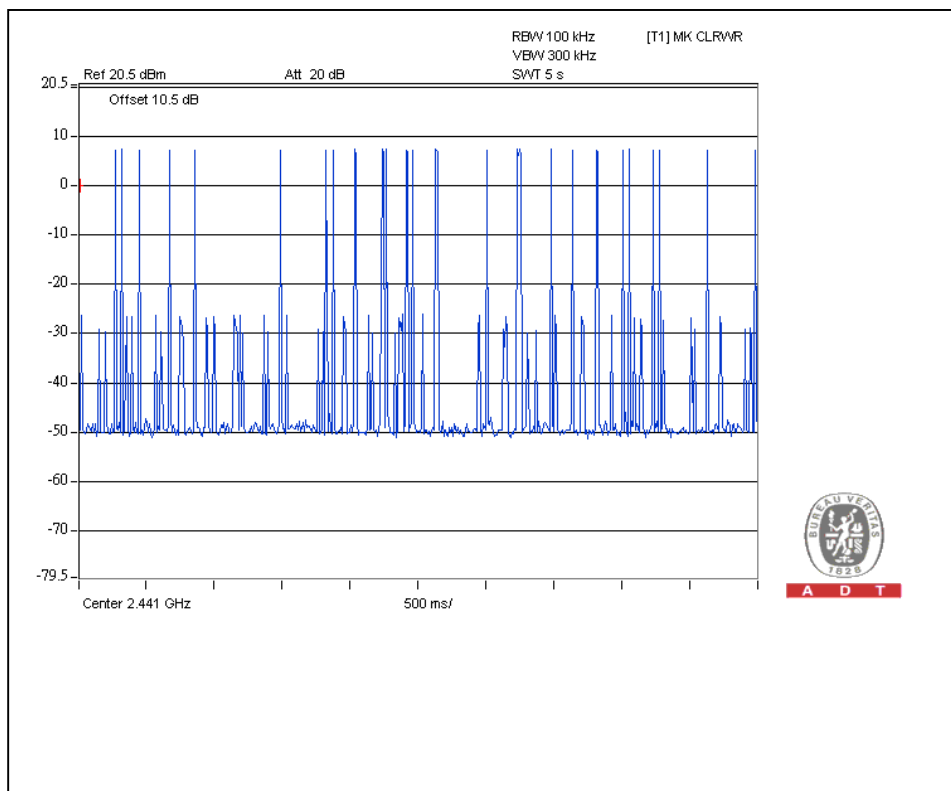



A D T

DH5

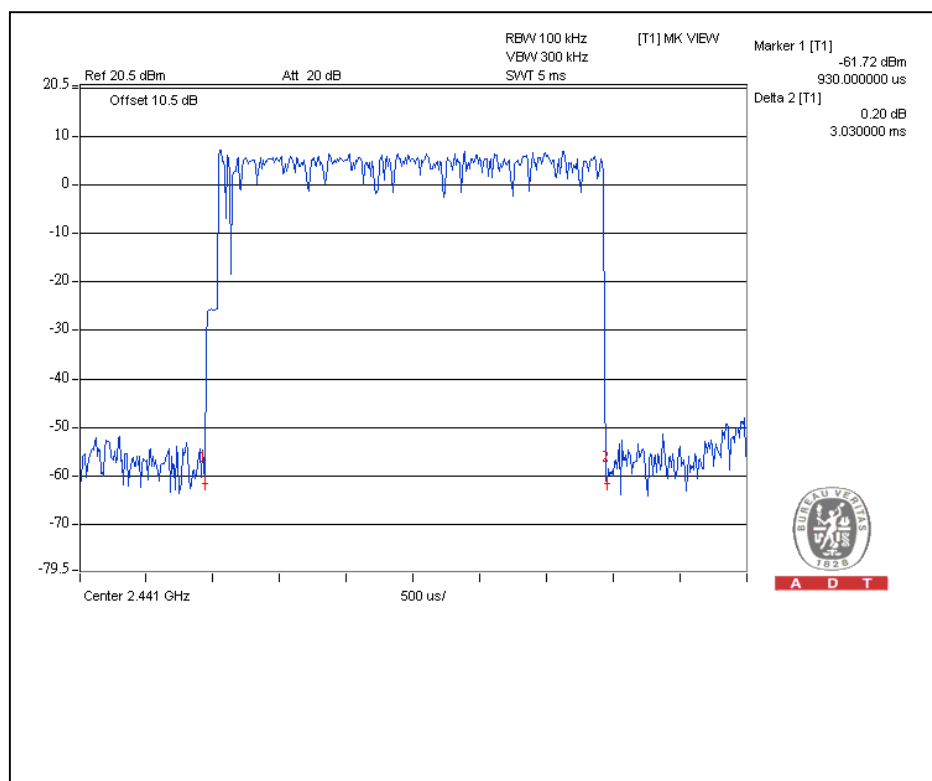
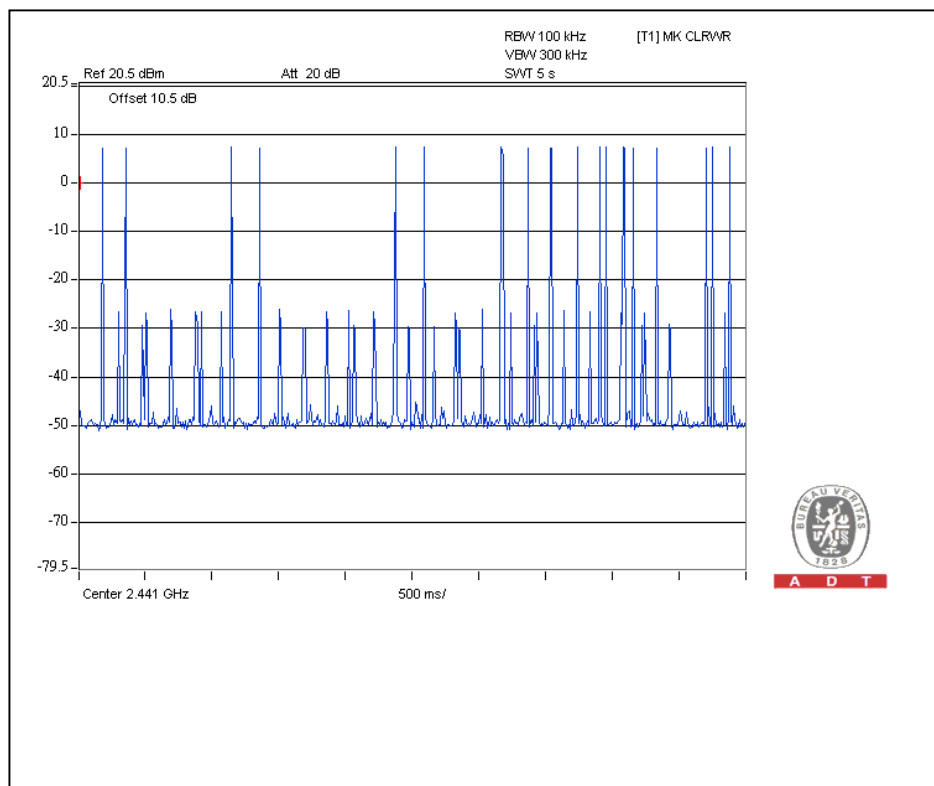



A D T

For $\pi/4$ -DQPSK :

Mode	Number of transmission in a 31.6 (79Hopping*0.4)	Length of transmission time (msec)	Result (msec)	Limit (msec)
DH1	51 (times / 5 sec) *6.32=322.32 times	0.516	166.3	400
DH3	26 (times / 5 sec) *6.32=164.32 times	1.782	292.8	400
DH5	16 (times / 5 sec) *6.32=101.12 times	3.03	306.4	400

Test plots of the transmitting time slot are shown on next three pages.



A D T

DH1

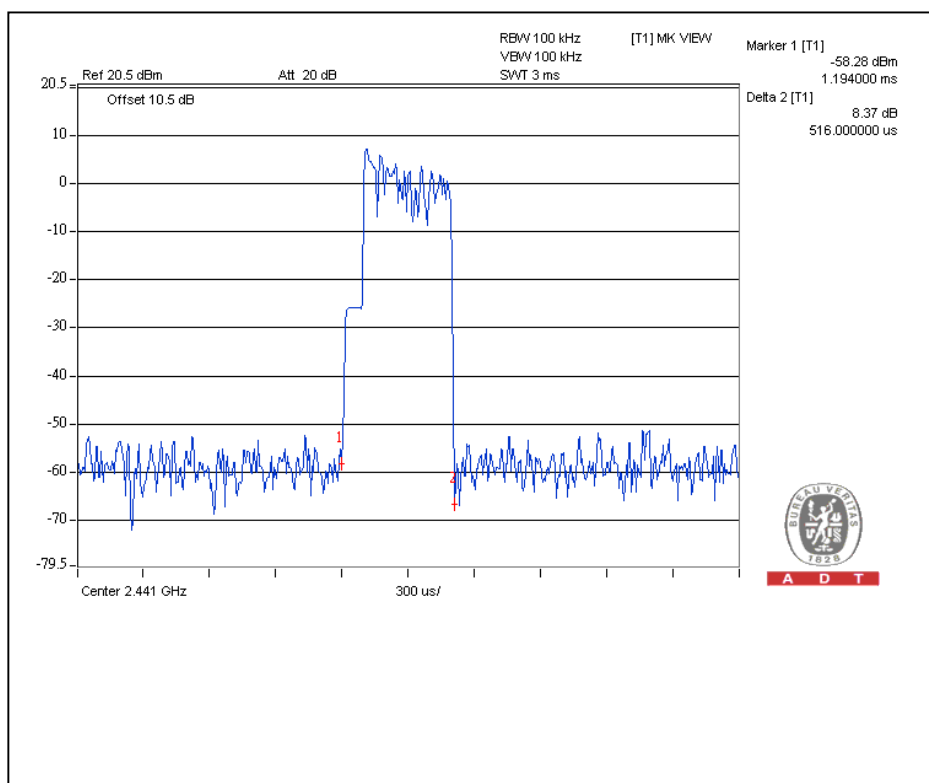
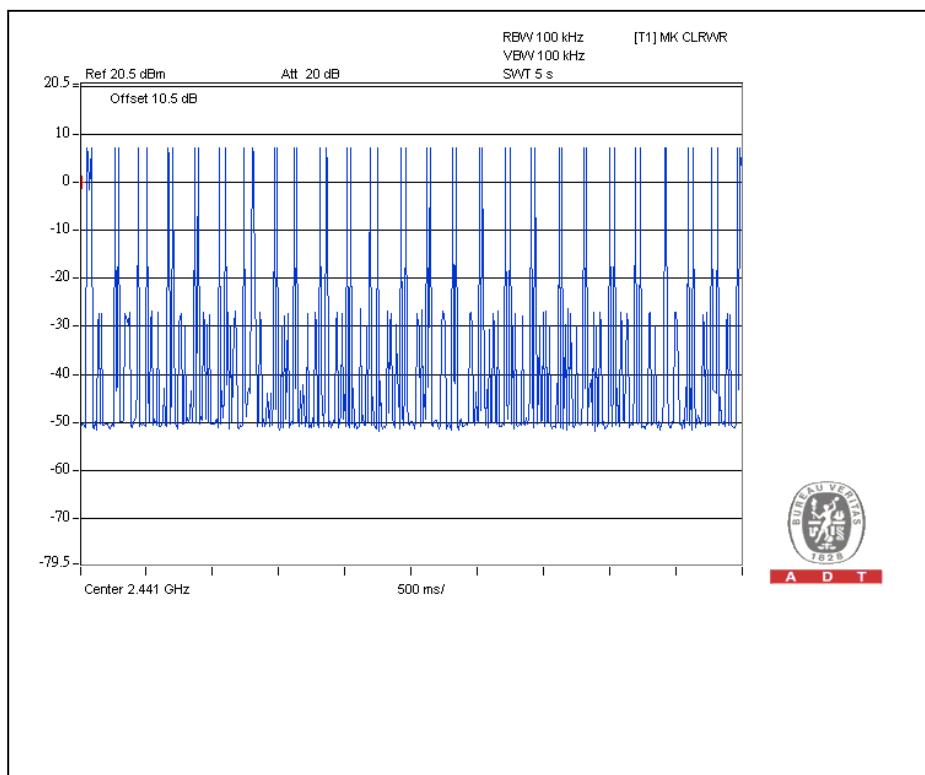



A D T

DH3

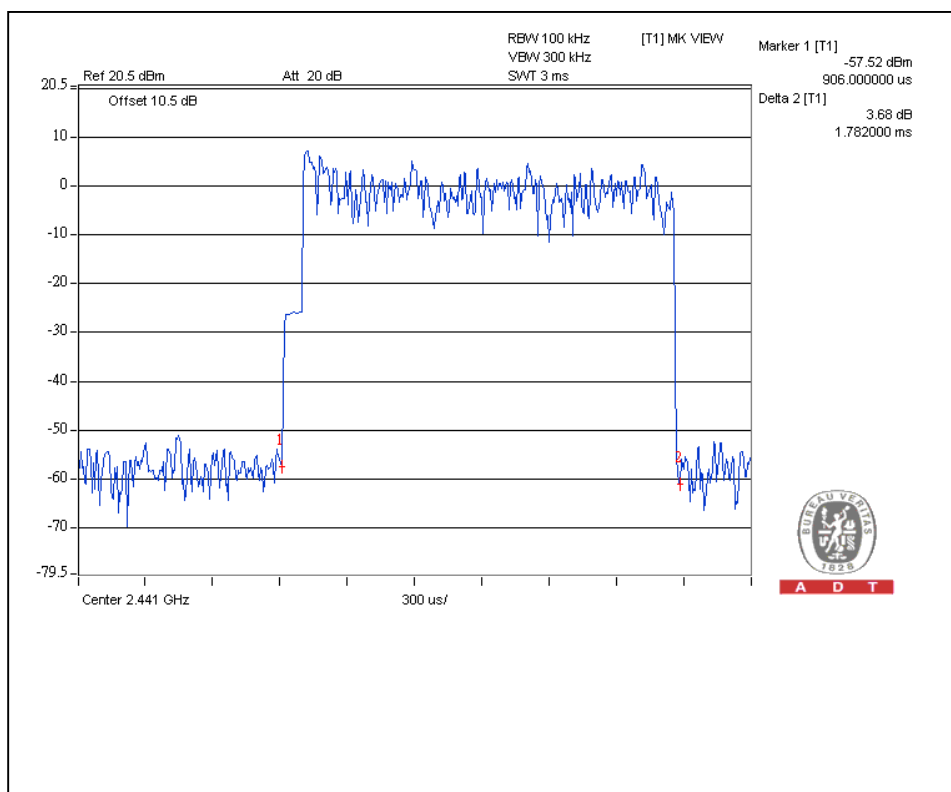
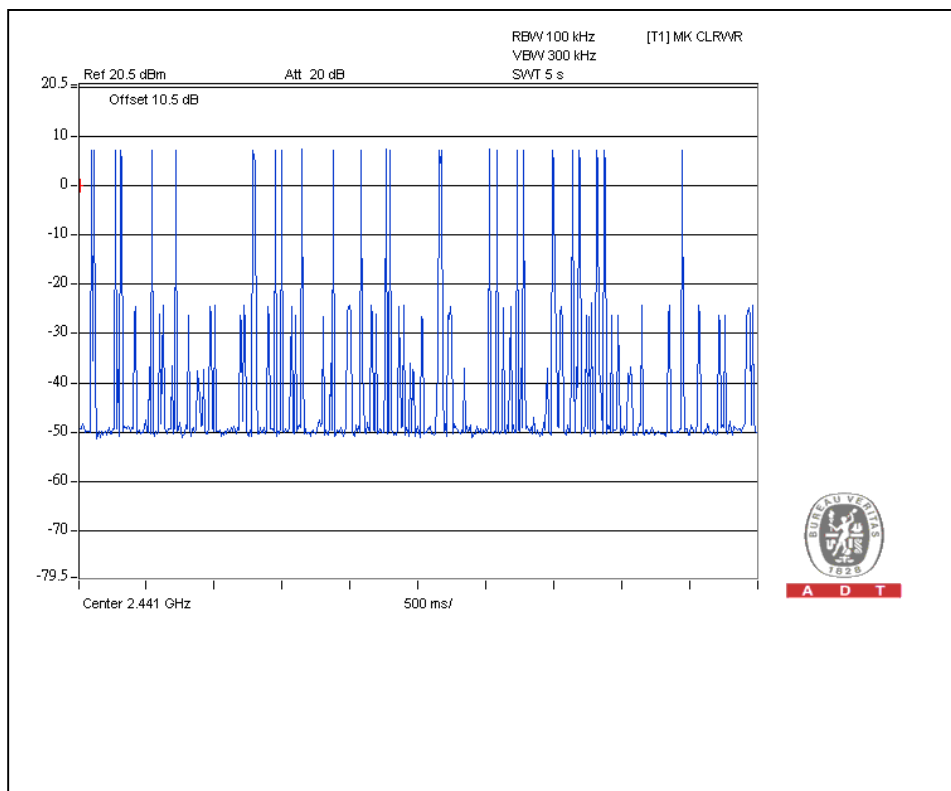



A D T

DH5

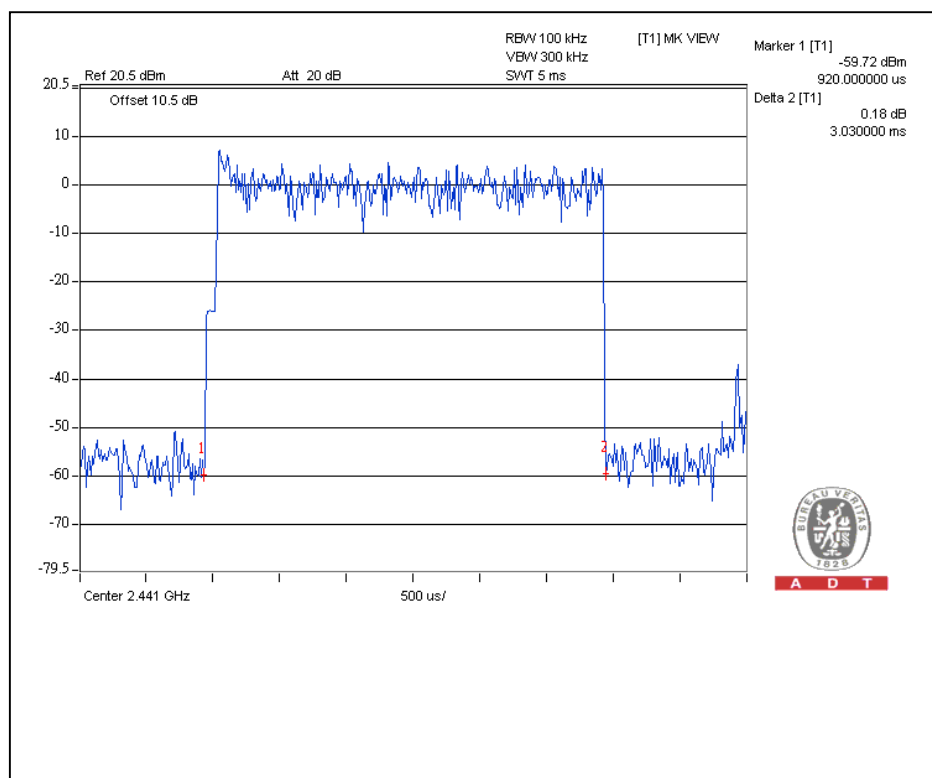
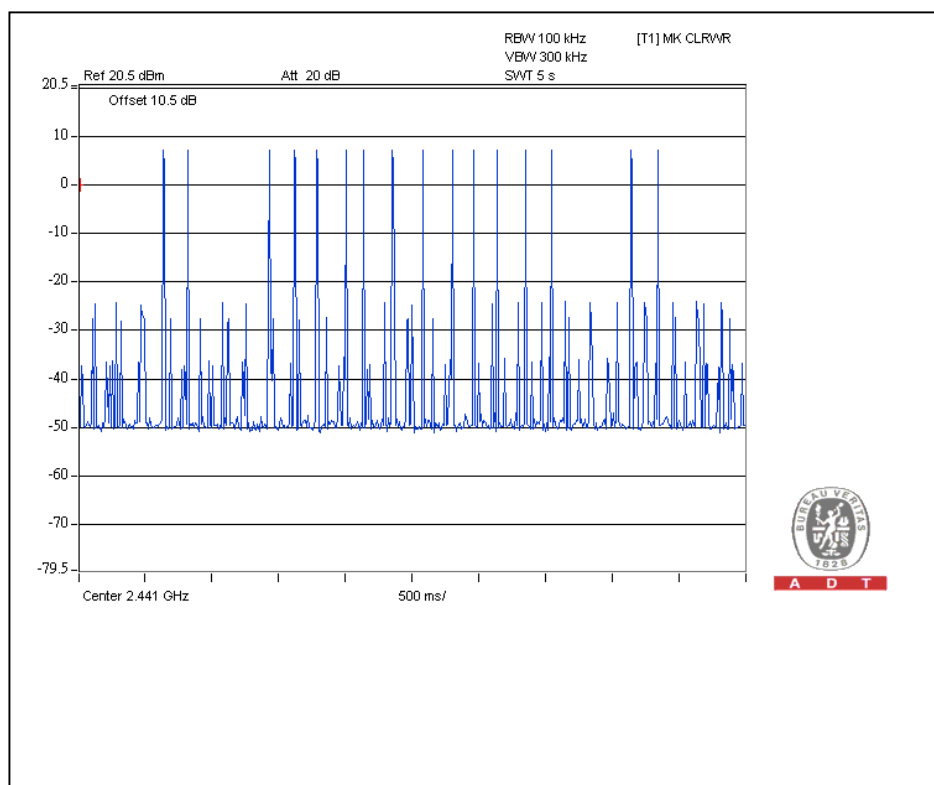



A D T

For 8DPSK:

Mode	Number of transmission in a 31.6 (79Hopping*0.4)	Length of transmission time (msec)	Result (msec)	Limit (msec)
DH1	50 (times / 5 sec) *6.32=316 times	0.534	168.7	400
DH3	27 (times / 5 sec) *6.32=170.64 times	1.77	302	400
DH5	17 (times / 5 sec) *6.32=107.44 times	3.03	325.5	400

Test plots of the transmitting time slot are shown on next three pages.



A D T

DH1

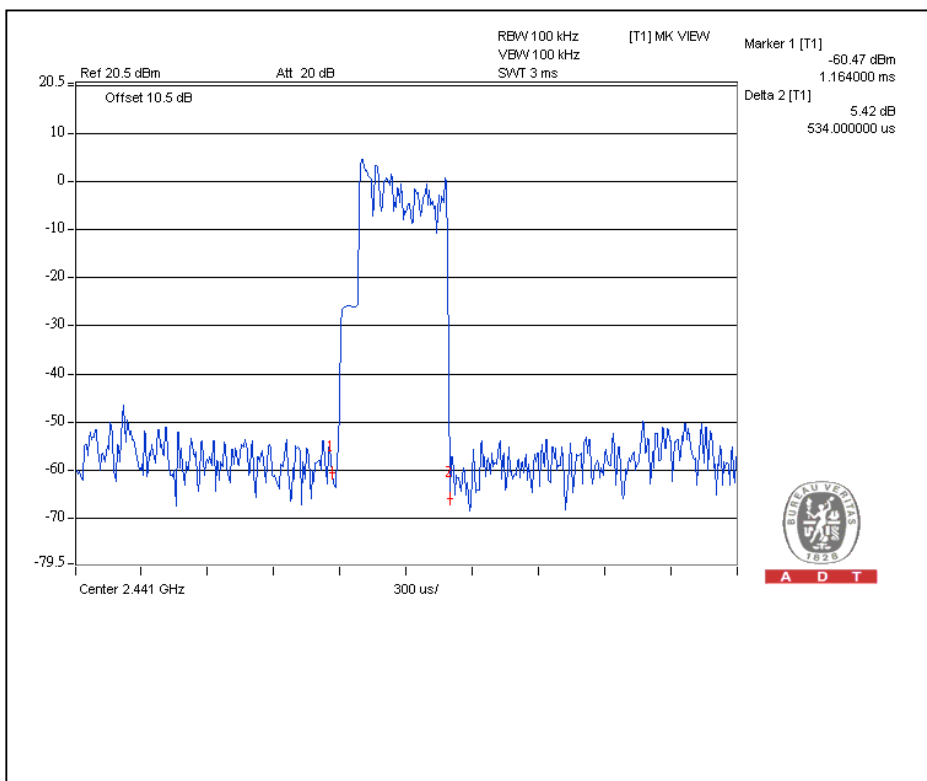



A D T

DH3

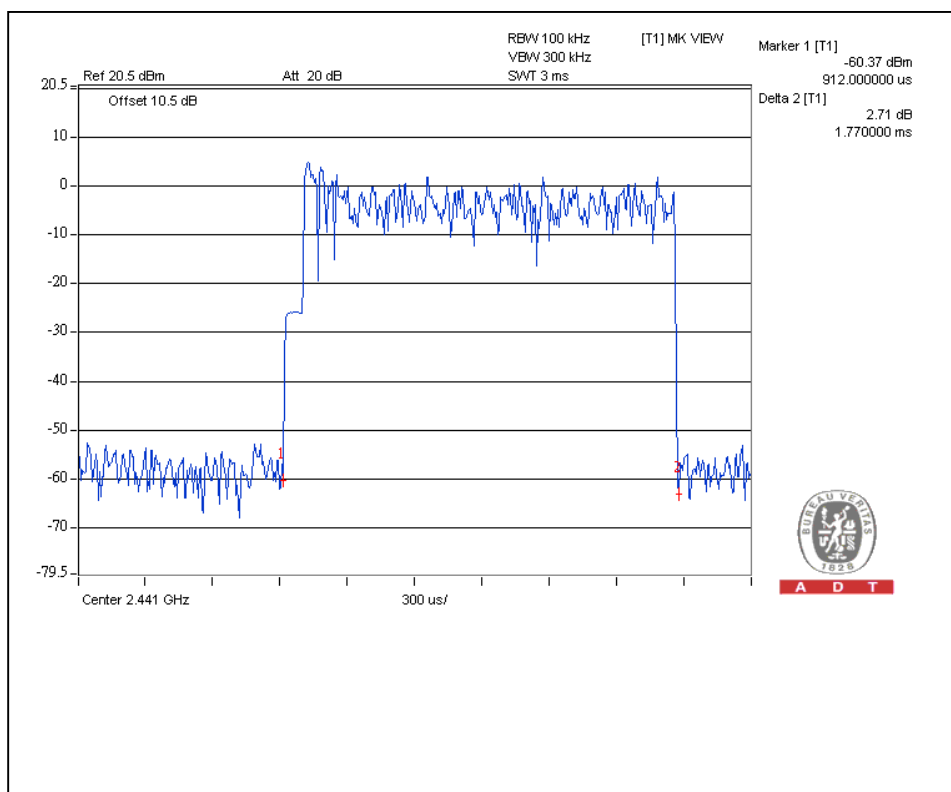
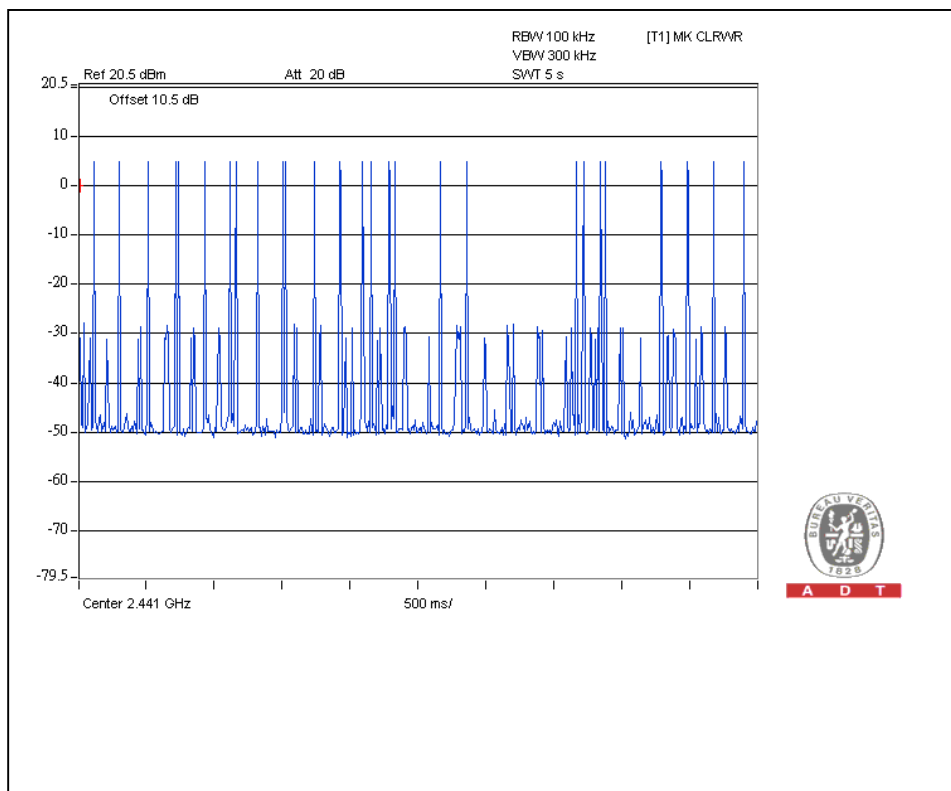



A D T

DH5

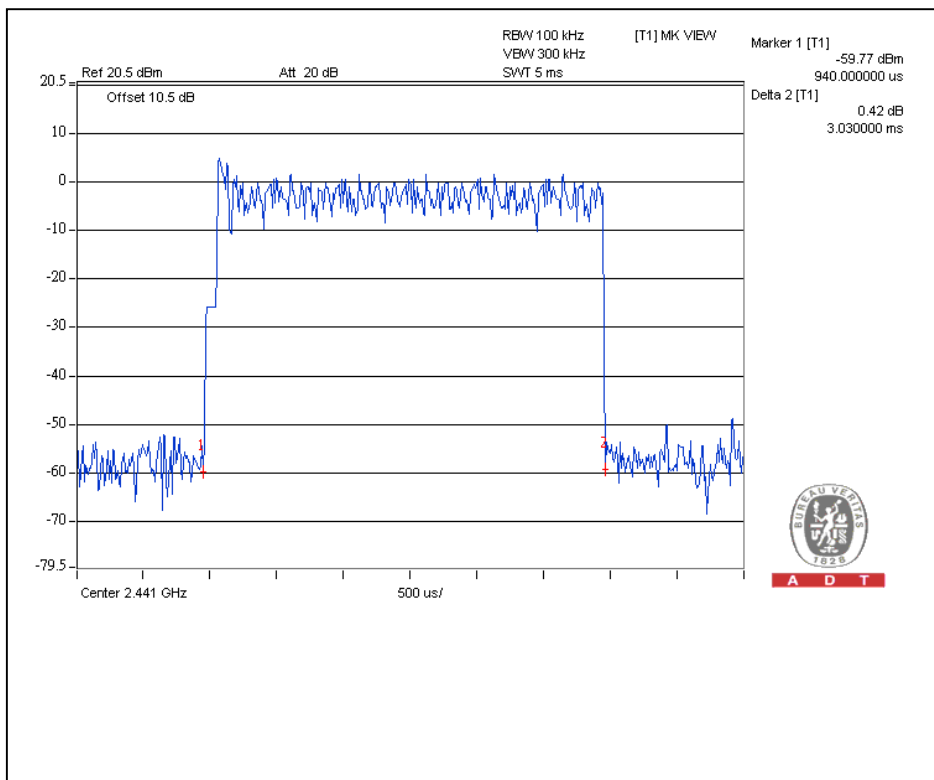
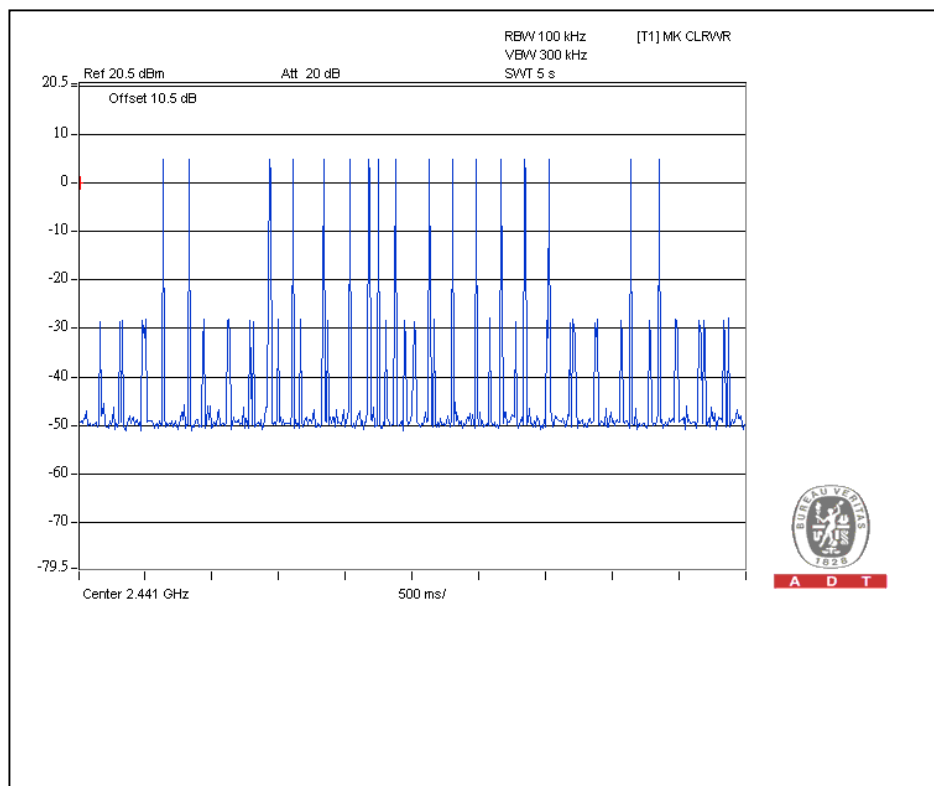

4.4 CHANNEL BANDWIDTH

4.4.1 LIMITS OF CHANNEL BANDWIDTH

For frequency hopping system operating in the 2400-2483.5MHz, If the two-thirds 20dB bandwidth of hopping channel is greater than 25kHz, two-thirds 20dB bandwidth of hopping channel shall be a minimum limit for the hopping channel separation.

4.4.2 TEST INSTRUMENTS

DESCRIPTION & MANUFACTURER	MODEL NO.	SERIAL NO.	CALIBRATED DATE	CALIBRATED UNTIL
PSA Seviess Spectrum Analyzer	FSP40	100036	Dec. 08, 2010	Dec. 07, 2011

NOTE: The calibration interval of the above test instruments is 12 months and the calibrations are traceable to NML/ROC and NIST/USA.

4.4.3 TEST PROCEDURE

1. Check the calibration of the measuring instrument using either an internal calibrator or a known signal from an external generator.
2. Turn on the EUT and connect it to measurement instrument. Then set it to any one convenient frequency within its operating range. Set a reference level on the measuring instrument equal to the highest peak value.
3. Measure the frequency difference of two frequencies that were attenuated 20dB from the reference level. Record the frequency difference as the emission bandwidth.
4. Repeat above procedures until all frequencies measured were complete.

4.4.4 DEVIATION FROM TEST STANDARD

No deviation

4.4.5 TEST SETUP

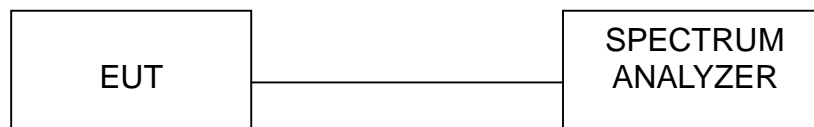

4.4.6 EUT OPERATING CONDITION

The software provided by client enabled the EUT to transmit and receive data at lowest, middle and highest channel frequencies individually.



A D T

4.4.7 TEST RESULTS

For GFSK:

CHANNEL	CHANNEL FREQUENCY (MHz)	20dB BANDWIDTH (MHz)
0	2402	0.94
39	2441	0.94
78	2480	0.94

Channel 0

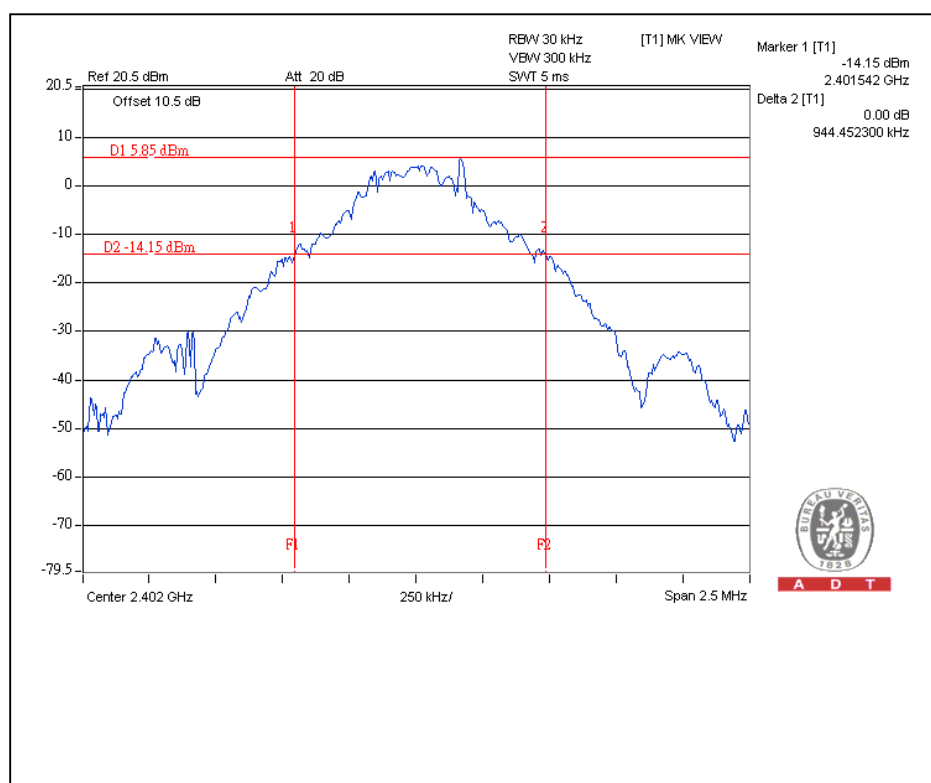



A D T

For $\pi/4$ -DQPSK:

CHANNEL	CHANNEL FREQUENCY (MHz)	20dB BANDWIDTH (MHz)
0	2402	1.31
39	2441	1.32
78	2480	1.32

Channel 39

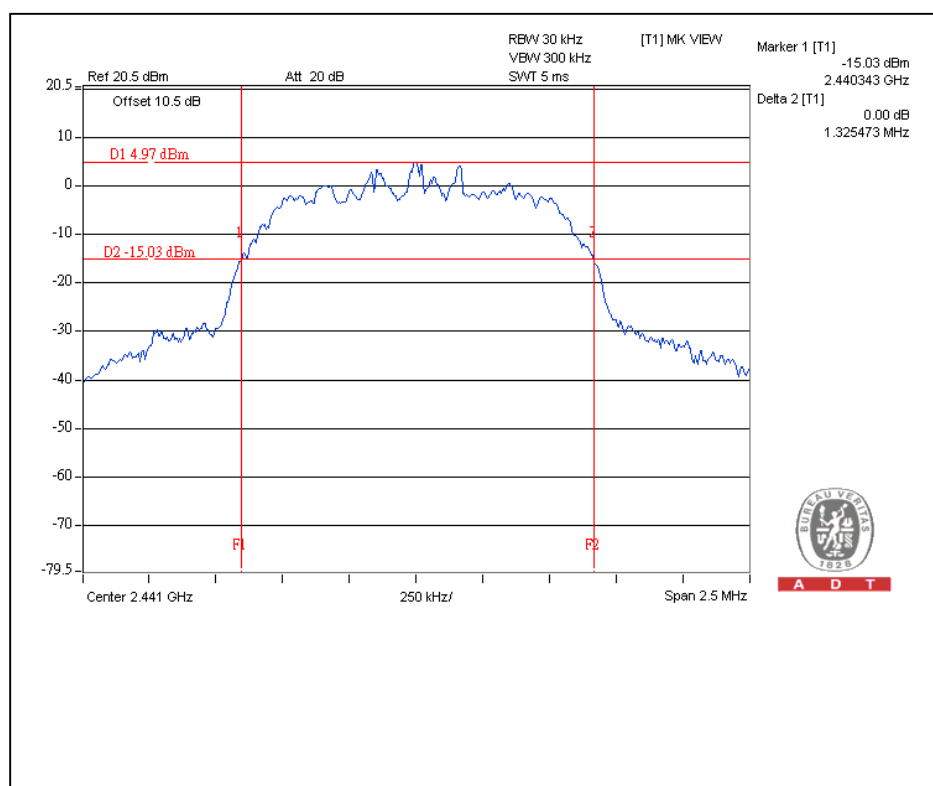



A D T

For 8DPSK:

CHANNEL	CHANNEL FREQUENCY (MHz)	20dB BANDWIDTH (MHz)
0	2402	1.30
39	2441	1.30
78	2480	1.30

Channel 39

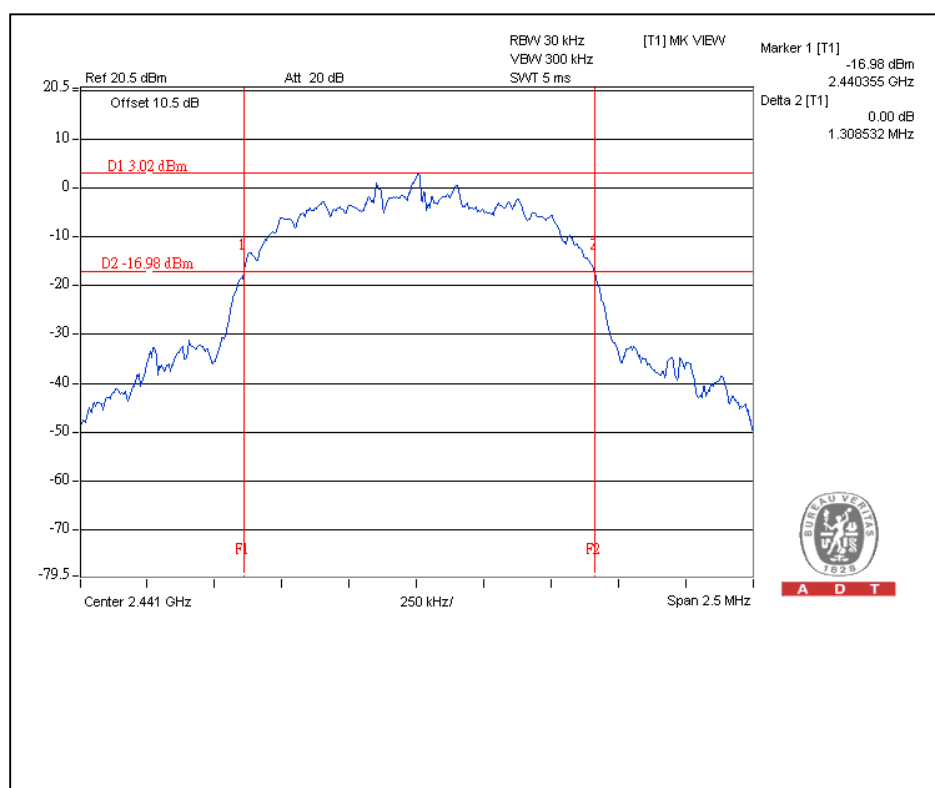

4.5 HOPPING CHANNEL SEPARATION

4.5.1 LIMIT OF HOPPING CHANNEL SEPARATION

At least 25 kHz or two-thirds of 20dB hopping channel bandwidth (whichever is greater).

4.5.2 TEST INSTRUMENTS

DESCRIPTION & MANUFACTURER	MODEL NO.	SERIAL NO.	CALIBRATED DATE	CALIBRATED UNTIL
PSA Sevius Spectrum Analyzer	FSP40	100036	Dec. 08, 2010	Dec. 07, 2011

NOTE: The calibration interval of the above test instruments is 12 months and the calibrations are traceable to NML/ROC and NIST/USA.

4.5.3 TEST PROCEDURES

1. Check the calibration of the measuring instrument using either an internal calibrator or a known signal from an external generator.
2. Turn on the EUT and connect it to measurement instrument. Then set it to any one convenient frequency within its operating range.
3. By using the MaxHold function record the separation of two adjacent channels.
4. Measure the frequency difference of these two adjacent channels by SA MARK function. And then plot the result on SA screen.
5. Repeat above procedures until all frequencies measured were complete.

4.5.4 DEVIATION FROM TEST STANDARD

No deviation

4.5.5 TEST SETUP





A D T

4.5.6 TEST RESULTS

For GFSK

Channel	Frequency (MHz)	Adjacent Channel Separation (MHz)	Minimum Limit (MHz)	Pass / Fail
0	2402	1.001	0.627	PASS
39	2441	1.003	0.627	PASS
78	2480	1.001	0.627	PASS

The minimum limit is two-thirds of 20dB bandwidth. Test results please refer to below pages.

Channel 0

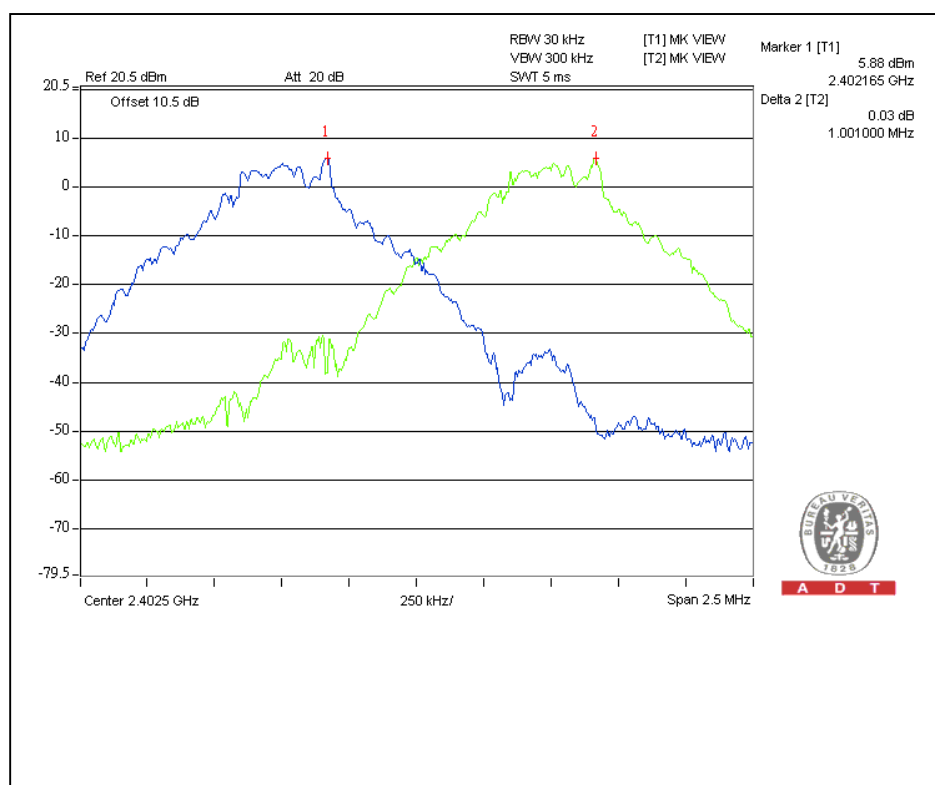



A D T

Channel 39

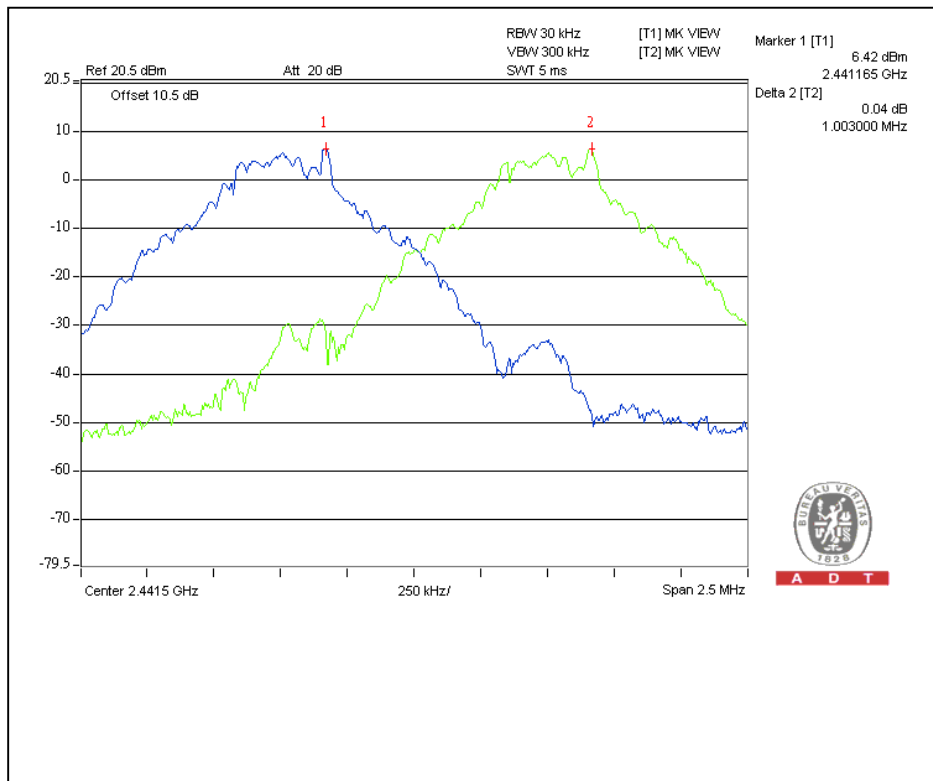

Channel 78

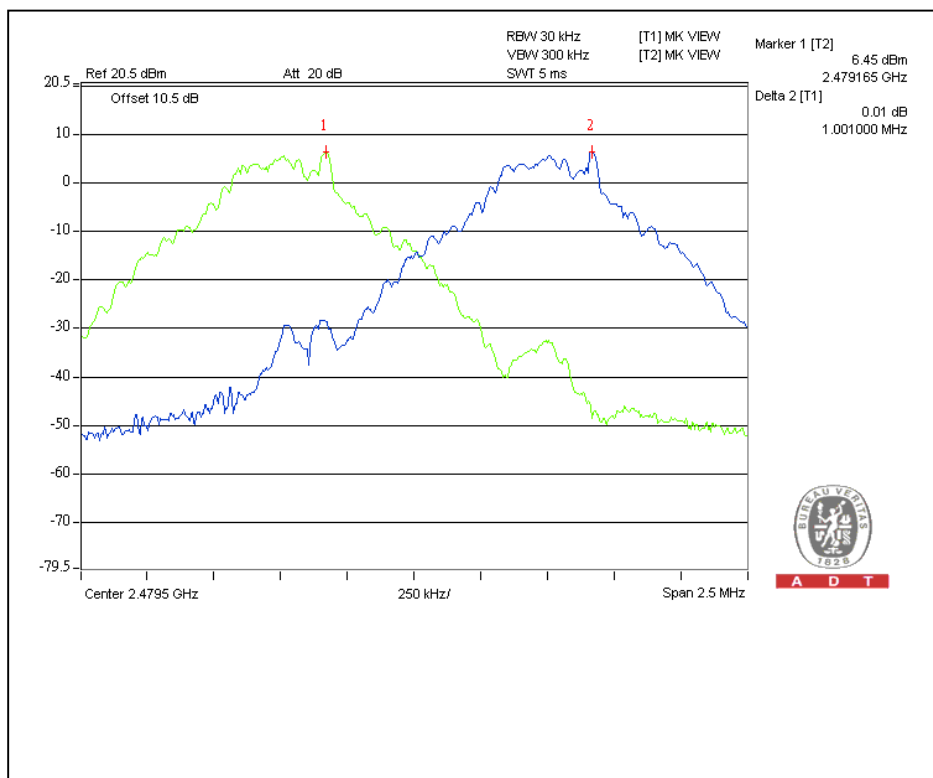



A D T

For $\pi/4$ -DQPSK

Channel	Frequency (MHz)	Adjacent Channel Separation (MHz)	Minimum Limit (MHz)	Pass / Fail
0	2402	1.007	0.873	PASS
39	2441	1.004	0.880	PASS
78	2480	1.003	0.880	PASS

The minimum limit is two-thirds of 20dB bandwidth. Test results please refer to below pages.

Channel 0

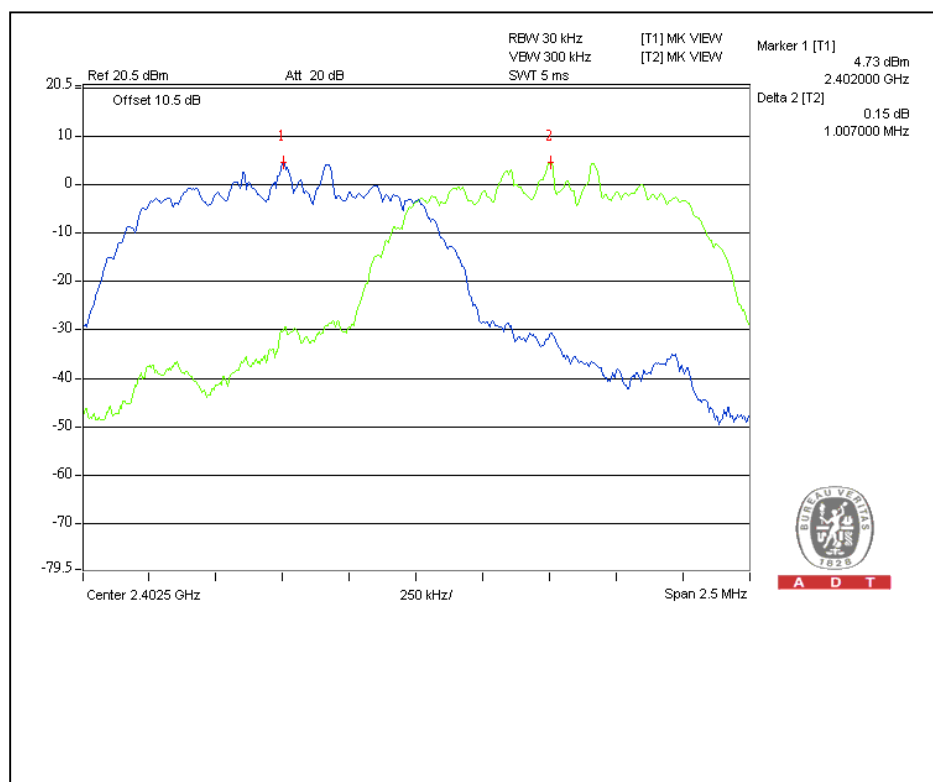



A D T

Channel 39

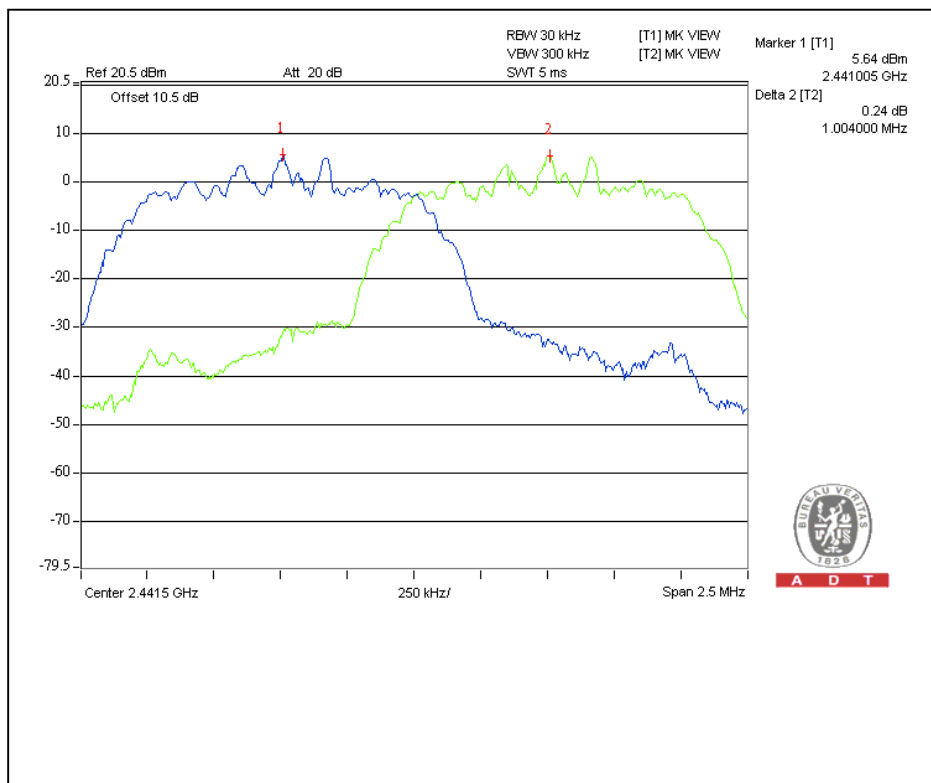

Channel 78





A D T

For 8DPSK

Channel	Frequency (MHz)	Adjacent Channel Separation (MHz)	Minimum Limit (MHz)	Pass / Fail
0	2402	1.008	0.867	PASS
39	2441	1.001	0.867	PASS
78	2480	1.001	0.867	PASS

The minimum limit is two-thirds of 20dB bandwidth. Test results please refer to below pages.

Channel 0

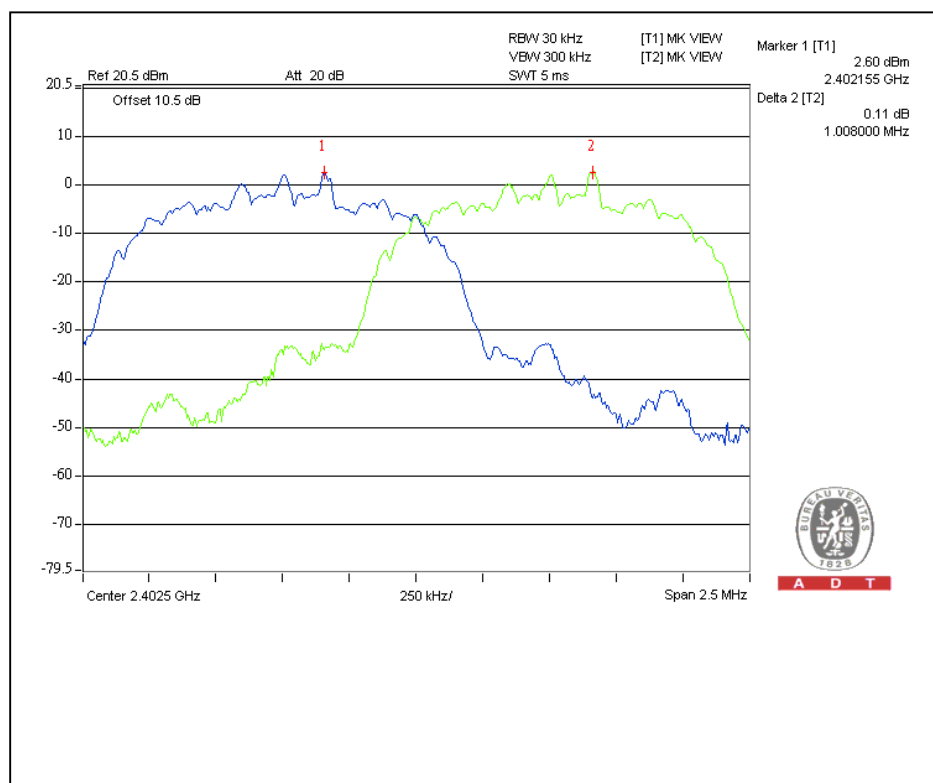

4.6 MAXIMUM PEAK OUTPUT POWER

4.6.1 LIMITS OF MAXIMUM PEAK OUTPUT POWER MEASUREMENT

The Maximum Peak Output Power Limit is 125mW.

4.6.2 INSTRUMENTS

DESCRIPTION & MANUFACTURER	MODEL NO.	SERIAL NO.	CALIBRATED DATE	CALIBRATED UNTIL
PSA Seviés Spectrum Analyzer	FSP40	100036	Dec. 08, 2010	Dec. 07, 2011

NOTE: The calibration interval of the above test instruments is 12 months and the calibrations are traceable to NML/ROC and NIST/USA.

4.6.3 TEST PROCEDURES

1. Check the calibration of the measuring instrument using either an internal calibrator or a known signal from an external generator.
2. Turn on the EUT and connect it to measurement instrument. Then set it to any one convenient frequency within its operating range. Set a reference level on the measuring instrument equal to the highest peak value.
3. The center frequency of the spectrum analyzer is set to the fundamental frequency and using 3 MHz RBW and 10 MHz VBW.
4. Measure the captured power within the band and recording the plot.
5. Repeat above procedures until all frequencies measured were complete.

4.6.4 DEVIATION FROM TEST STANDARD

No deviation

4.6.5 TEST SETUP

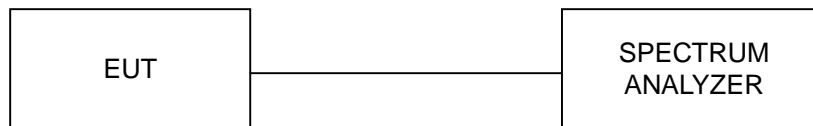

For the actual test configuration, please refer to the related Item – Photographs of the Test Configuration.

4.6.6 EUT OPERATING CONDITION

The software provided by client enabled the EUT to transmit and receive data at lowest, middle and highest channel frequencies individually.



A D T

4.6.7 TEST RESULTS

For GFSK

CHANNEL	CHANNEL FREQUENCY (MHz)	PEAK POWER OUTPUT (dBm)	PEAK POWER OUTPUT (mW)	PEAK POWER LIMIT (mW)	PASS/FAIL
0	2402	8.1	6.5	125	PASS
39	2441	8.7	7.4	125	PASS
78	2480	8.7	7.4	125	PASS

Channel 39

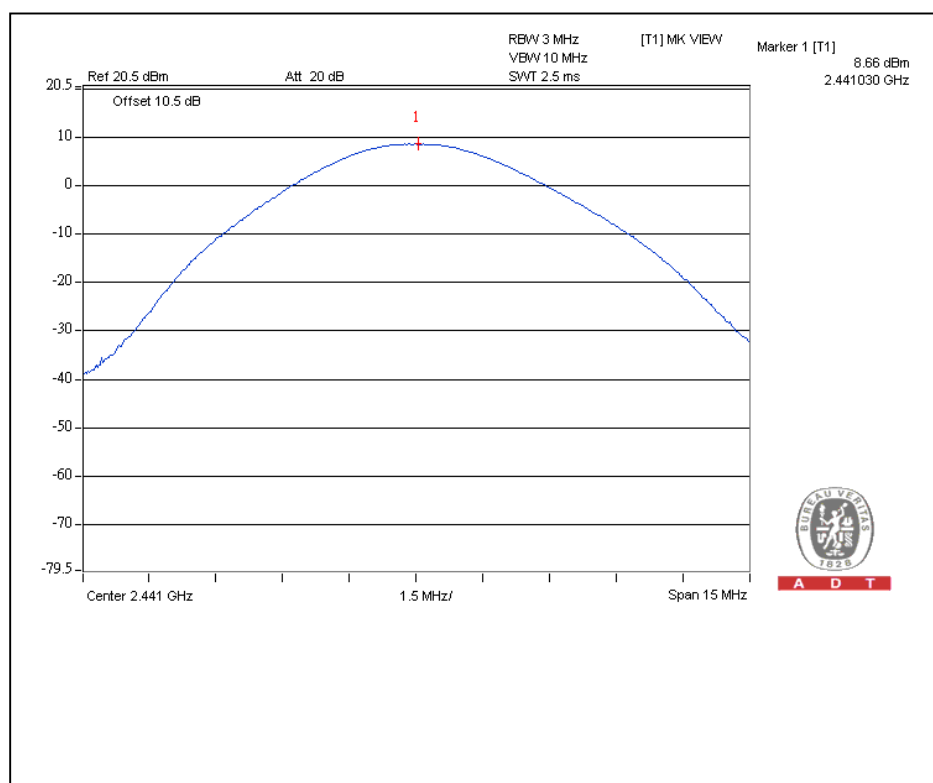



A D T

For $\pi/4$ -DQPSK

CHANNEL	CHANNEL FREQUENCY (MHz)	PEAK POWER OUTPUT (dBm)	PEAK POWER OUTPUT (mW)	PEAK POWER LIMIT (mW)	PASS/FAIL
0	2402	10.1	10.2	125	PASS
39	2441	10.6	11.5	125	PASS
78	2480	10.6	11.5	125	PASS

Channel 39

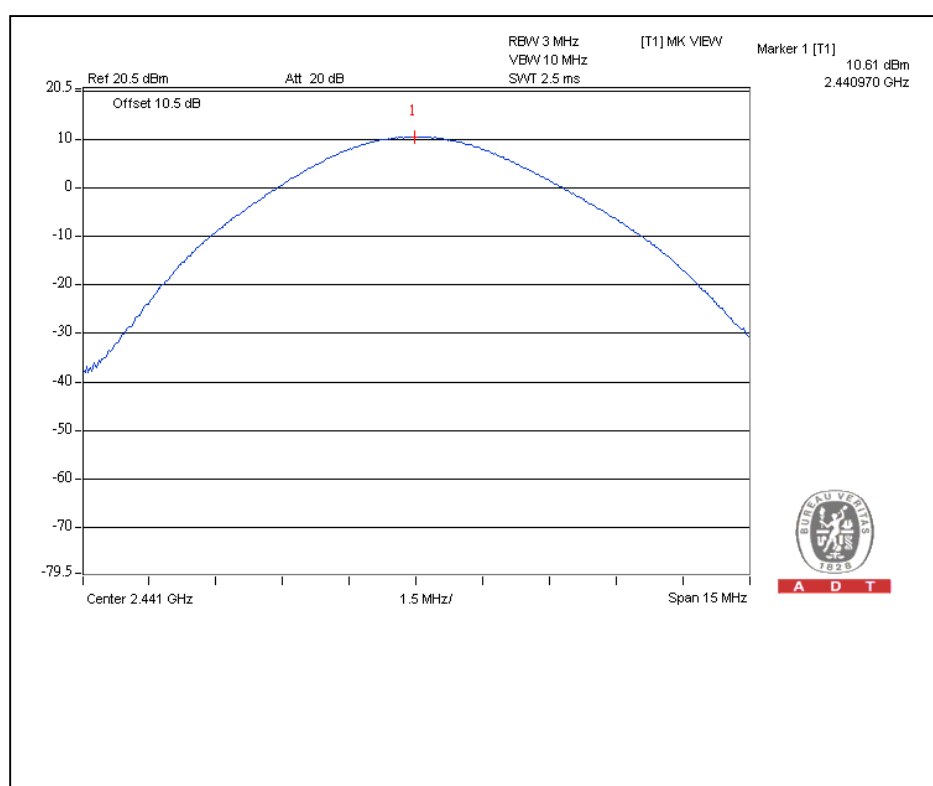



A D T

For 8DPSK

CHANNEL	CHANNEL FREQUENCY (MHz)	PEAK POWER OUTPUT (dBm)	PEAK POWER OUTPUT (mW)	PEAK POWER LIMIT (mW)	PASS/FAIL
0	2402	7.6	5.8	125	PASS
39	2441	8.5	7.1	125	PASS
78	2480	8.8	7.6	125	PASS

Channel 78

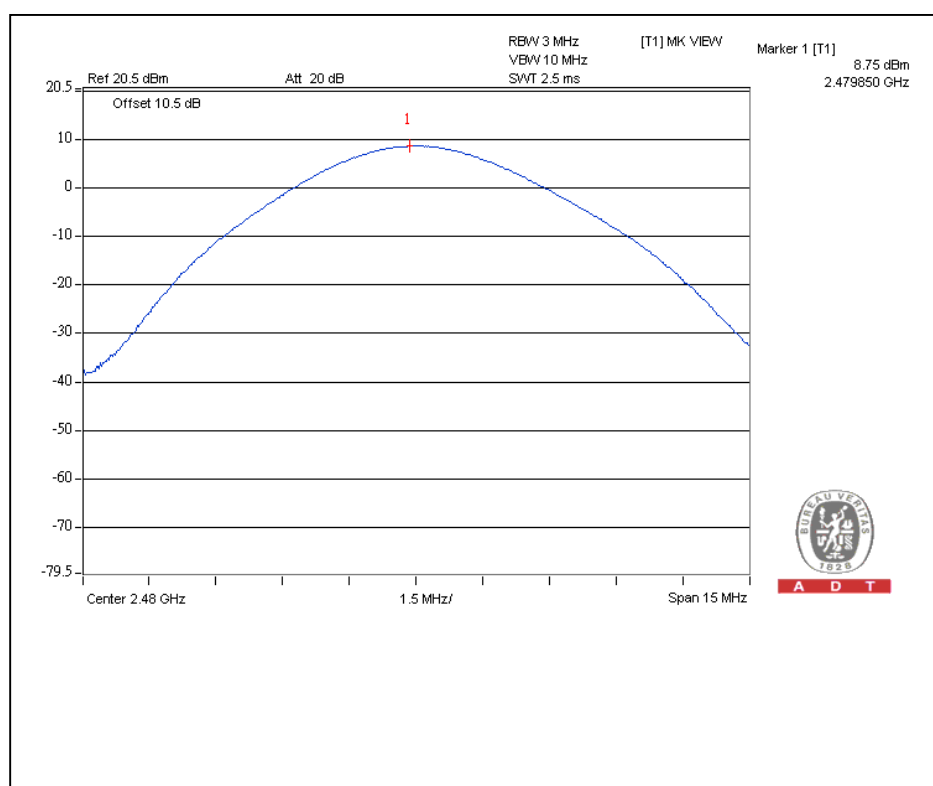

4.7 RADIATED EMISSION MEASUREMENT

4.7.1 LIMITS OF RADIATED EMISSION MEASUREMENT

Emissions radiated outside of the specified bands, shall be according to the general radiated limits in 15.209 as following:

Frequencies (MHz)	Field strength (microvolts/meter)	Measurement distance (meters)
0.009-0.490	2400/F(kHz)	300
0.490-1.705	24000/F(kHz)	30
1.705-30.0	30	30
30-88	100	3
88-216	150	3
216-960	200	3
Above 960	500	3

1. As shown in 15.35(b), for frequencies above 1000MHz, the field strength limits are based on average detector, however, the peak field strength of any emission shall not exceed the maximum permitted average limits, specified above by more than 20dB under any condition of modulation.
2. Section 15.205 restricted bands of operation shall compliance with the limits in Section 15.209.

4.7.2 TEST INSTRUMENTS

Below 1GHz test:

DESCRIPTION & MANUFACTURER	MODEL NO.	SERIAL NO.	CALIBRATED DATE	CALIBRATED UNTIL
Agilent Spectrum Analyzer	E4446A	MY48250253	Aug. 23, 2010	Aug. 22, 2011
Agilent Pre-Selector	N9039A	MY46520310	Aug. 23, 2010	Aug. 22, 2011
Agilent Signal Generator	N5181A	MY49060347	July 30, 2010	July 29, 2011
LIG NEX1 Test Receiver	ER-265	L09068005	Oct. 25, 2010	Oct. 24, 2011
Mini-Circuits Pre-Amplifier	ZFL-1000VH2B	AMP-ZFL-04	Nov. 16, 2010	Nov. 15, 2011
Agilent Pre-Amplifier	8449B	3008A02465	Mar. 01, 2010	Feb. 28, 2011
Miteq Pre-Amplifier	AFS33-1800265 0-30-8P-44	881786	NA	NA
SCHWARZBECK Trilog Broadband Antenna	VULB 9168	9168-361	Apr. 28, 2010	Apr. 27, 2011
AISI Horn_Antenna	AIH.8018	0000220091110	Nov. 22, 2010	Nov. 21, 2011
SCHWARZBECK Horn_Antenna	BBHA 9170	9170-424	Oct. 08, 2010	Oct. 07, 2011
RF CABLE	NA	RF104-205 RF104-207 RF104-202	Dec. 28, 2010	Dec. 27, 2011
RF Cable	NA	CHHCAB_001	NA	NA
Software	ADT_Radiated_V8.7.05	NA	NA	NA
CT Antenna Tower & Turn Table	NA	NA	NA	NA

Note: 1. The calibration interval of the above test instruments is 12 months and the calibrations are traceable to NML/ROC and NIST/USA.

2. The horn antenna, preamplifier (model: 8449B) are used only for the measurement of emission frequency above 1GHz if tested.

3. The test was performed in 966 Chamber No. H.

4. The FCC Site Registration No. is 797305.

5. The CANADA Site Registration No. is IC 7450H-3.



A D T

Above 1GHz test:

DESCRIPTION & MANUFACTURER	MODEL NO.	SERIAL NO.	CALIBRATED DATE	CALIBRATED UNTIL
Agilent Spectrum Analyzer	E4446A	MY48250254	July 14, 2010	July 13, 2011
Agilent Pre-Selector	N9039A	MY46520311	July 14, 2010	July 13, 2011
Agilent Signal Generator	N5181A	MY49060517	July 14, 2010	July 13, 2011
Mini-Circuits Pre-Amplifier	ZFL-1000VH2B	AMP-ZFL-03	Nov. 16, 2010	Nov. 15, 2011
Agilent Pre-Amplifier	8449B	3008A02578	July 05, 2010	July 04, 2011
Miteq Pre-Amplifier	AFS33-1800265 0-30-8P-44	881786	NA	NA
SCHWARZBECK Trilog Broadband Antenna	VULB 9168	9168-360	Apr. 29, 2010	Apr. 28, 2011
AISI Horn_Antenna	AIH.8018	0000320091110	Nov. 12, 2010	Nov. 11, 2011
SCHWARZBECK Horn_Antenna	BBHA 9170	9170-424	Oct. 08, 2010	Oct. 07, 2011
RF CABLE	NA	RF104-201 RF104-203 RF104-204	Dec. 27, 2010	Dec. 26, 2011
RF Cable	NA	CHGCAB_001	NA	NA
Software	ADT_Radiated_V8.7.05	NA	NA	NA
CT Antenna Tower & Turn Table	NA	NA	NA	NA

- Note: 1. The calibration interval of the above test instruments is 12 months and the calibrations are traceable to NML/ROC and NIST/USA.
2. The horn antenna, preamplifier (model: 8449B) are used only for the measurement of emission frequency above 1GHz if tested.
3. The test was performed in 966 Chamber No. G.
4. The FCC Site Registration No. is 966073.
5. The VCCI Site Registration No. is G-137.
6. The CANADA Site Registration No. is IC 7450H-2.

4.7.3 TEST PROCEDURES

- a. The EUT was placed on the top of a rotating table 0.8 meters above the ground at 3 meters chamber room. The table was rotated 360 degrees to determine the position of the highest radiation.
- b. The EUT was set 3 meters away from the interference-receiving antenna, which was mounted on the top of a variable-height antenna tower.
- c. The height of antenna is varied from one meter to four meters above the ground to determine the maximum value of the field strength. Both horizontal and vertical polarizations of the antenna are set to make the measurement.
- d. For each suspected emission, the EUT was arranged to its worst case and then the antenna was tuned to heights from 1 meter to 4 meters and the rotatable table was turned from 0 degrees to 360 degrees to find the maximum reading.
- e. The test-receiver system was set to quasi-peak detect function and specified bandwidth with maximum hold mode when the test frequency is below 1 GHz.
- f. The test-receiver system was set to peak detect function and specified bandwidth with maximum hold mode when the test frequency is above 1 GHz.

NOTE:

1. The resolution bandwidth and video bandwidth of test receiver/spectrum analyzer is 120kHz for Peak detection (PK) and Quasi-peak detection (QP) at frequency below 1GHz.
2. The resolution bandwidth is 1MHz and video bandwidth of test receiver/spectrum analyzer is 3MHz for Peak detection at frequency above 1GHz.

4.7.4 DEVIATION FROM TEST STANDARD

No deviation

4.7.5 TEST SETUP

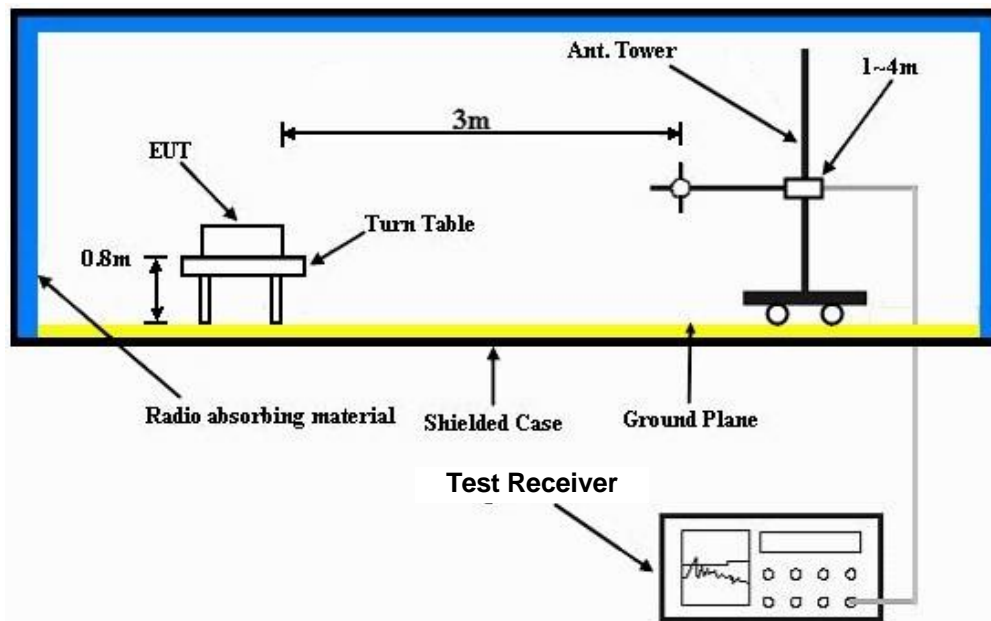

For the actual test configuration, please refer to the related item – Photographs of the Test Configuration.

4.7.6 EUT OPERATING CONDITIONS

Same as 4.1.6



4.7.7 TEST RESULTS

BELOW 1GHz WORST-CASE DATA : $\pi/4$ - DQPSK MODULATION

EUT TEST CONDITION		MEASUREMENT DETAIL	
CHANNEL	Channel 78	FREQUENCY RANGE	Below 1000MHz
INPUT POWER (SYSTEM)	120Vac, 60Hz	DETECTOR FUNCTION	Quasi-Peak
ENVIRONMENTAL CONDITIONS	21deg. C, 68%RH 1023 hPa	TESTED BY	Rex Huang

ANTENNA POLARITY & TEST DISTANCE: HORIZONTAL AT 3 M								
NO.	FREQ. (MHz)	EMISSION LEVEL (dBuV/m)	LIMIT (dBuV/m)	MARGIN (dB)	ANTENNA HEIGHT (m)	TABLE ANGLE (Degree)	RAW VALUE (dBuV)	CORRECTION FACTOR (dB/m)
1	71.92	33.7 QP	40.0	-6.3	2.25 H	350	21.91	11.83
2	108.06	42.5 QP	43.5	-1.0	1.75 H	334	31.44	11.02
3	168.08	38.4 QP	43.5	-5.1	1.75 H	59	24.46	13.92
4	240.08	42.4 QP	46.0	-3.6	1.00 H	0	29.87	12.56
5	264.12	40.6 QP	46.0	-5.4	1.00 H	0	27.15	13.47
6	312.20	44.3 QP	46.0	-1.7	1.00 H	0	28.97	15.29
7	336.36	43.4 QP	46.0	-2.7	1.00 H	360	27.35	16.00
8	408.36	39.8 QP	46.0	-6.3	2.00 H	69	21.71	18.04
9	528.32	37.7 QP	46.0	-8.3	1.50 H	49	17.02	20.67
10	647.93	38.1 QP	46.0	-7.9	1.25 H	42	15.42	22.69

ANTENNA POLARITY & TEST DISTANCE: VERTICAL AT 3 M								
NO.	FREQ. (MHz)	EMISSION LEVEL (dBuV/m)	LIMIT (dBuV/m)	MARGIN (dB)	ANTENNA HEIGHT (m)	TABLE ANGLE (Degree)	RAW VALUE (dBuV)	CORRECTION FACTOR (dB/m)
1	32.61	32.1 QP	40.0	-7.9	1.00 V	183	18.81	13.27
2	72.16	32.4 QP	40.0	-7.6	1.00 V	237	20.65	11.77
3	108.04	40.3 QP	43.5	-3.2	1.25 V	360	29.30	11.01
4	168.08	33.6 QP	43.5	-9.9	2.25 V	291	19.70	13.92
5	312.20	38.3 QP	46.0	-7.7	1.25 V	28	23.00	15.29
6	336.36	38.8 QP	46.0	-7.2	1.25 V	19	22.84	16.00
7	360.28	36.0 QP	46.0	-10.0	1.50 V	360	19.27	16.70
8	647.93	32.2 QP	46.0	-13.9	1.00 V	64	9.46	22.69

- REMARKS:**
1. Emission level (dBuV/m) = Raw Value (dBuV) + Correction Factor (dB/m).
 2. Correction Factor (dB/m) = Antenna Factor (dB/m) + Cable Factor (dB).
 3. The other emission levels were very low against the limit.
 4. Margin value = Emission level – Limit value.



A D T

ABOVE 1GHZ WORST-CASE DATA

GFSK MODULATION

EUT TEST CONDITION		MEASUREMENT DETAIL	
CHANNEL	Channel 0	FREQUENCY RANGE	1 ~ 25GHz
INPUT POWER (SYSTEM)	120Vac, 60Hz	DETECTOR FUNCTION	Peak (PK)
ENVIRONMENTAL CONDITIONS	19deg. C, 68%RH 1023 hPa	TESTED BY	Rex Huang

ANTENNA POLARITY & TEST DISTANCE: HORIZONTAL AT 3 M

NO.	FREQ. (MHz)	EMISSION LEVEL (dBuV/m)	LIMIT (dBuV/m)	MARGIN (dB)	ANTENNA HEIGHT (m)	TABLE ANGLE (Degree)	RAW VALUE (dBuV)	CORRECTION FACTOR (dB/m)
1	2390.00	56.0 PK	74.0	-18.0	1.00 H	250	24.34	31.66
2	2390.00	25.9 AV	54.0	-28.1	1.00 H	250	-5.76	31.66
3	*2402.00	104.5 PK			1.00 H	250	72.80	31.70
4	*2402.00	74.4 AV			1.00 H	250	42.70	31.70
5	4804.00	50.1 PK	74.0	-23.9	1.07 H	120	11.20	38.90
6	4804.00	20.0 AV	54.0	-34.0	1.07 H	120	-18.90	38.90

ANTENNA POLARITY & TEST DISTANCE: VERTICAL AT 3 M

NO.	FREQ. (MHz)	EMISSION LEVEL (dBuV/m)	LIMIT (dBuV/m)	MARGIN (dB)	ANTENNA HEIGHT (m)	TABLE ANGLE (Degree)	RAW VALUE (dBuV)	CORRECTION FACTOR (dB/m)
1	2390.00	57.3 PK	74.0	-16.7	1.00 V	65	25.64	31.66
2	2390.00	27.2 AV	54.0	-26.8	1.00 V	65	-4.46	31.66
3	*2402.00	101.1 PK			1.00 V	65	69.40	31.70
4	*2402.00	71.0 AV			1.00 V	65	39.30	31.70
5	4804.00	51.8 PK	74.0	-22.2	1.05 V	69	12.90	38.90
6	4804.00	21.7 AV	54.0	-32.3	1.05 V	69	-17.20	38.90

- REMARKS:**
1. Emission level (dBuV/m) = Raw Value (dBuV) + Correction Factor (dB/m).
 2. Correction Factor (dB/m) = Antenna Factor (dB/m) + Cable Factor (dB).
 3. The other emission levels were very low against the limit.
 4. Margin value = Emission level – Limit value.
 5. “ * “: Fundamental frequency.
 6. The DH5 packet was the worse case duty cycle for a transmit dwell time on a channel, based upon bluetooth theory the transmitter is on 0.625 * 5 per 296.25 ms per channel. Therefore, the duty cycle correlation factor be equal to: $20\log(3.125 / 100) = -30.1$ dB.
 7. Average value = peak reading + $20\log(\text{duty cycle})$.



A D T

EUT TEST CONDITION		MEASUREMENT DETAIL	
CHANNEL	Channel 39	FREQUENCY RANGE	1 ~ 25GHz
INPUT POWER (SYSTEM)	120Vac, 60Hz	DETECTOR FUNCTION	Peak (PK)
ENVIRONMENTAL CONDITIONS	19deg. C, 68%RH 1023 hPa	TESTED BY	Rex Huang

ANTENNA POLARITY & TEST DISTANCE: HORIZONTAL AT 3 M								
NO.	FREQ. (MHz)	EMISSION LEVEL (dBuV/m)	LIMIT (dBuV/m)	MARGIN (dB)	ANTENNA HEIGHT (m)	TABLE ANGLE (Degree)	RAW VALUE (dBuV)	CORRECTION FACTOR (dB/m)
1	*2441.00	104.6 PK			1.00 H	251	72.77	31.83
2	*2441.00	74.5 AV			1.00 H	251	42.67	31.83
3	4882.00	50.4 PK	74.0	-23.6	1.06 H	125	11.23	39.17
4	4882.00	20.3 AV	54.0	-33.7	1.06 H	125	-18.87	39.17
ANTENNA POLARITY & TEST DISTANCE: VERTICAL AT 3 M								
NO.	FREQ. (MHz)	EMISSION LEVEL (dBuV/m)	LIMIT (dBuV/m)	MARGIN (dB)	ANTENNA HEIGHT (m)	TABLE ANGLE (Degree)	RAW VALUE (dBuV)	CORRECTION FACTOR (dB/m)
1	*2441.00	101.1 PK			1.00 V	66	69.27	31.83
2	*2441.00	71.0 AV			1.00 V	66	39.17	31.83
3	4882.00	52.0 PK	74.0	-22.0	1.04 V	68	12.83	39.17
4	4882.00	21.9 AV	54.0	-32.1	1.04 V	68	-17.27	39.17
5	7323.00	53.1 PK	74.0	-20.9	1.00 V	236	6.47	46.63
6	7323.00	23.0 AV	54.0	-31.0	1.00 V	236	-23.63	46.63

- REMARKS:**
1. Emission level (dBuV/m) = Raw Value (dBuV) + Correction Factor (dB/m).
 2. Correction Factor (dB/m) = Antenna Factor (dB/m) + Cable Factor (dB).
 3. The other emission levels were very low against the limit.
 4. Margin value = Emission level – Limit value.
 5. “ * ”: Fundamental frequency.
 6. The DH5 packet was the worse case duty cycle for a transmit dwell time on a channel, based upon bluetooth theory the transmitter is on 0.625 * 5 per 296.25 ms per channel. Therefore, the duty cycle correlation factor be equal to: $20\log(3.125 / 100) = -30.1$ dB.
 7. Average value = peak reading + 20log(duty cycle).



A D T

EUT TEST CONDITION		MEASUREMENT DETAIL	
CHANNEL	Channel 78	FREQUENCY RANGE	1 ~ 25GHz
INPUT POWER (SYSTEM)	120Vac, 60Hz	DETECTOR FUNCTION	Peak (PK)
ENVIRONMENTAL CONDITIONS	19deg. C, 68%RH 1023 hPa	TESTED BY	Rex Huang

ANTENNA POLARITY & TEST DISTANCE: HORIZONTAL AT 3 M								
NO.	FREQ. (MHz)	EMISSION LEVEL (dBuV/m)	LIMIT (dBuV/m)	MARGIN (dB)	ANTENNA HEIGHT (m)	TABLE ANGLE (Degree)	RAW VALUE (dBuV)	CORRECTION FACTOR (dB/m)
1	*2480.00	104.7 PK			1.00 H	252	72.75	31.95
2	*2480.00	74.6 AV			1.00 H	252	42.65	31.95
3	2483.50	56.0 PK	74.0	-18.0	1.00 H	252	24.03	31.97
4	2483.50	25.9 AV	54.0	-28.1	1.00 H	252	-6.07	31.97
5	4960.00	51.2 PK	74.0	-22.8	1.07 H	121	11.78	39.42
6	4960.00	21.1 AV	54.0	-32.9	1.07 H	121	-18.32	39.42
7	7440.00	54.4 PK	74.0	-19.6	1.45 H	162	7.84	46.56
8	7440.00	24.3 AV	54.0	-29.7	1.45 H	162	-22.26	46.56
ANTENNA POLARITY & TEST DISTANCE: VERTICAL AT 3 M								
NO.	FREQ. (MHz)	EMISSION LEVEL (dBuV/m)	LIMIT (dBuV/m)	MARGIN (dB)	ANTENNA HEIGHT (m)	TABLE ANGLE (Degree)	RAW VALUE (dBuV)	CORRECTION FACTOR (dB/m)
1	*2480.00	100.2 PK			1.00 V	64	68.25	31.95
2	*2480.00	70.1 AV			1.00 V	64	38.15	31.95
3	2483.50	56.6 PK	74.0	-17.4	1.00 V	64	24.63	31.97
4	2483.50	26.5 AV	54.0	-27.5	1.00 V	64	-5.47	31.97
5	4960.00	51.7 PK	74.0	-22.3	1.05 V	72	12.28	39.42
6	4960.00	21.6 AV	54.0	-32.4	1.05 V	72	-17.82	39.42
7	7440.00	53.4 PK	74.0	-20.6	1.00 V	212	6.84	46.56
8	7440.00	23.3 AV	54.0	-30.7	1.00 V	212	-23.26	46.56

- REMARKS:**
- Emission level (dBuV/m) = Raw Value (dBuV) + Correction Factor (dB/m).
 - Correction Factor (dB/m) = Antenna Factor (dB/m) + Cable Factor (dB).
 - The other emission levels were very low against the limit.
 - Margin value = Emission level – Limit value.
 - * * *: Fundamental frequency.
 - The DH5 packet was the worse case duty cycle for a transmit dwell time on a channel, based upon bluetooth theory the transmitter is on 0.625 * 5 per 296.25 ms per channel. Therefore, the duty cycle correlation factor be equal to: $20\log(3.125 / 100) = -30.1$ dB.
 - Average value = peak reading + $20\log(\text{duty cycle})$.

RESTRICTED BANDEDGE (GFSK MODE, CH0, HORIZONTAL)

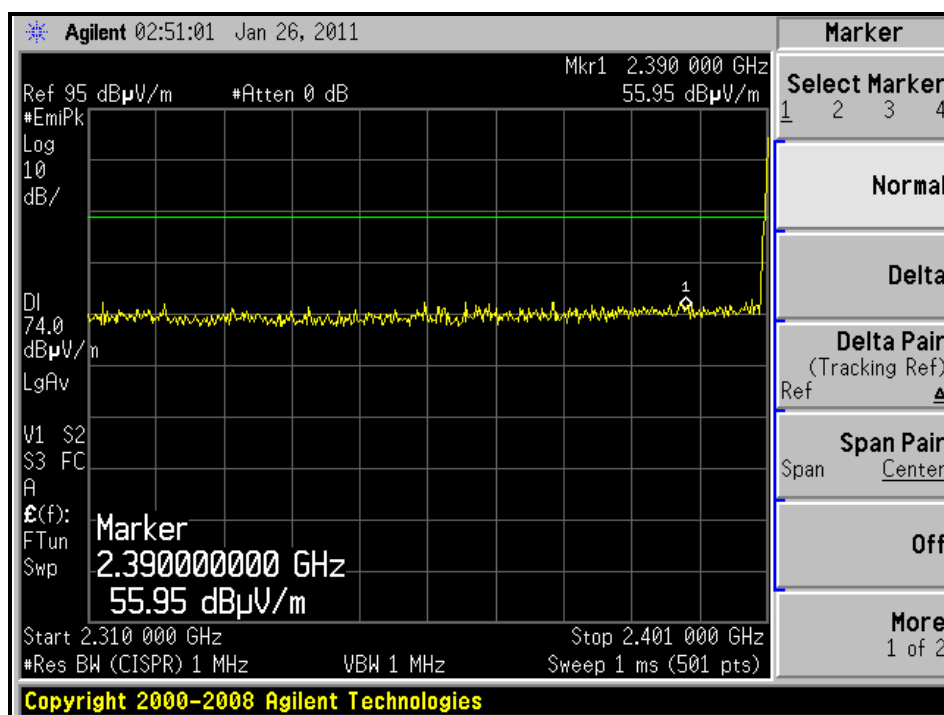

RESTRICTED BANDEDGE (GFSK MODE, CH0, VERTICAL)

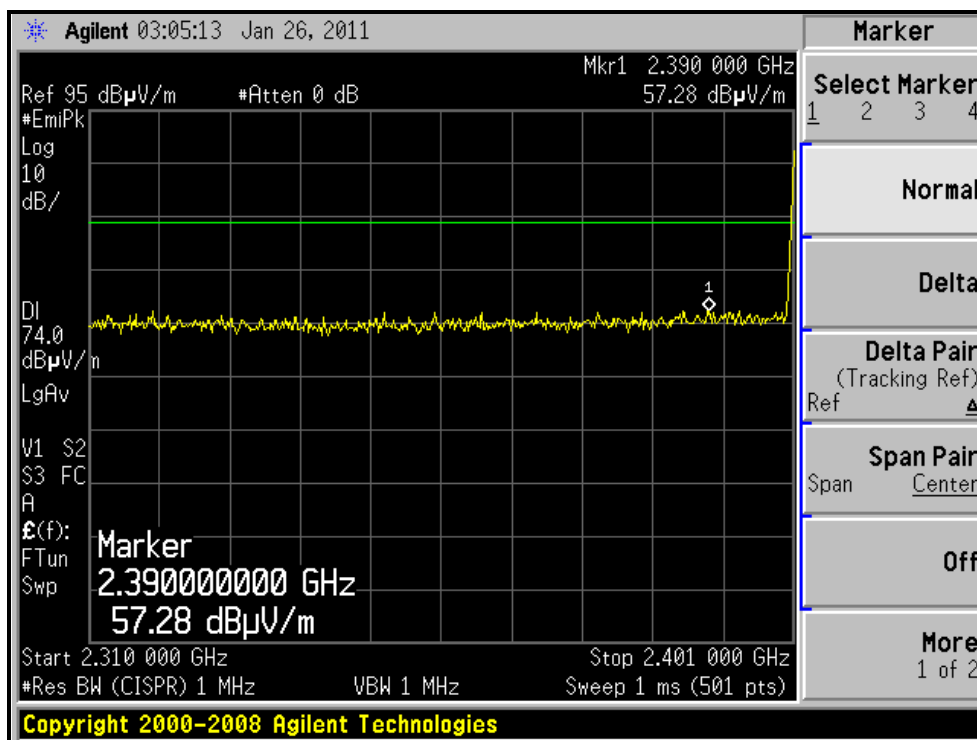

* The average value of fundamental frequency is: Average value = peak reading + 20log(duty cycle). And it meets the requirement of limit.

RESTRICTED BANDEDGE (GFSK MODE, CH78, HORIZONTAL)

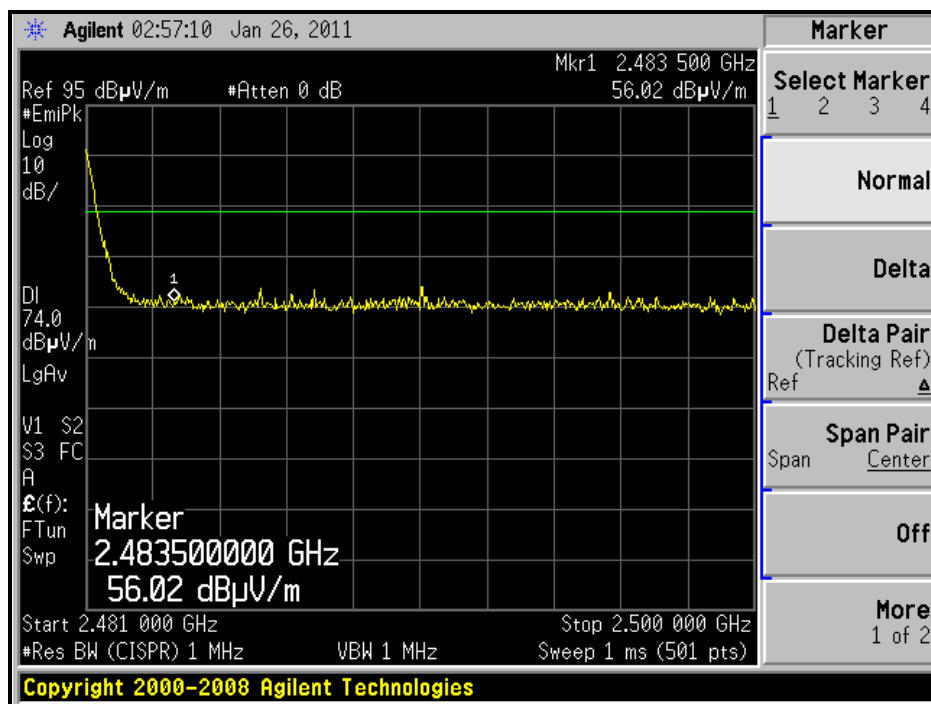

RESTRICTED BANDEDGE (GFSK MODE, CH78, VERTICAL)

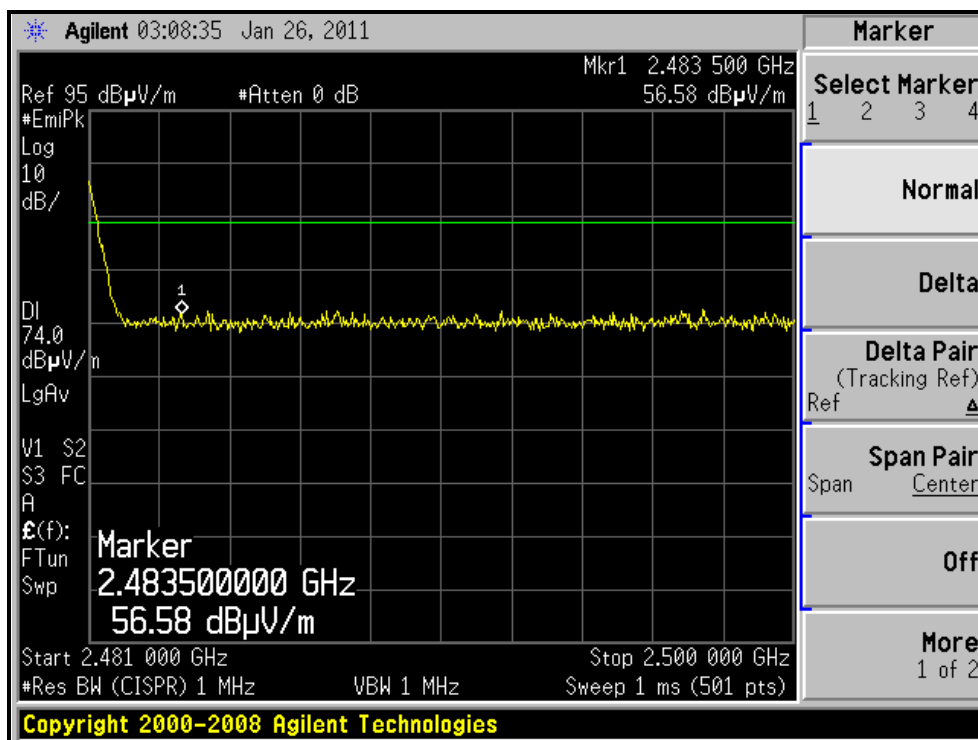

* The average value of fundamental frequency is: Average value = peak reading + 20log(duty cycle). And it meets the requirement of limit.



8DPSK MODULATION

EUT TEST CONDITION		MEASUREMENT DETAIL	
CHANNEL	Channel 0	FREQUENCY RANGE	1 ~ 25GHz
INPUT POWER (SYSTEM)	120Vac, 60Hz	DETECTOR FUNCTION	Peak (PK)
ENVIRONMENTAL CONDITIONS	19deg. C, 68%RH 1023 hPa	TESTED BY	Rex Huang

ANTENNA POLARITY & TEST DISTANCE: HORIZONTAL AT 3 M								
NO.	FREQ. (MHz)	EMISSION LEVEL (dBuV/m)	LIMIT (dBuV/m)	MARGIN (dB)	ANTENNA HEIGHT (m)	TABLE ANGLE (Degree)	RAW VALUE (dBuV)	CORRECTION FACTOR (dB/m)
1	2390.00	57.6 PK	74.0	-16.4	1.00 H	249	25.94	31.66
2	2390.00	27.5 AV	54.0	-26.5	1.00 H	249	-4.16	31.66
3	*2402.00	105.9 PK			1.00 H	249	74.20	31.70
4	*2402.00	75.8 AV			1.00 H	249	44.10	31.70
5	4804.00	50.2 PK	74.0	-23.8	1.05 H	120	11.30	38.90
6	4804.00	20.1 AV	54.0	-33.9	1.05 H	120	-18.80	38.90

ANTENNA POLARITY & TEST DISTANCE: VERTICAL AT 3 M								
NO.	FREQ. (MHz)	EMISSION LEVEL (dBuV/m)	LIMIT (dBuV/m)	MARGIN (dB)	ANTENNA HEIGHT (m)	TABLE ANGLE (Degree)	RAW VALUE (dBuV)	CORRECTION FACTOR (dB/m)
1	2390.00	57.9 PK	74.0	-16.1	1.00 V	65	26.24	31.66
2	2390.00	27.8 AV	54.0	-26.2	1.00 V	65	-3.86	31.66
3	*2402.00	102.2 PK			1.00 V	65	70.50	31.70
4	*2402.00	72.1 AV			1.00 V	65	40.40	31.70
5	4804.00	51.2 PK	74.0	-22.8	1.06 V	67	12.30	38.90
6	4804.00	21.1 AV	54.0	-32.9	1.06 V	67	-17.80	38.90

- REMARKS:**
1. Emission level (dBuV/m) = Raw Value (dBuV) + Correction Factor (dB/m).
 2. Correction Factor (dB/m) = Antenna Factor (dB/m) + Cable Factor (dB).
 3. The other emission levels were very low against the limit.
 4. Margin value = Emission level – Limit value.
 5. “ * ”: Fundamental frequency.
 6. The DH5 packet was the worse case duty cycle for a transmit dwell time on a channel, based upon bluetooth theory the transmitter is on 0.625 * 5 per 296.25 ms per channel. Therefore, the duty cycle correlation factor be equal to: $20\log(3.125 / 100) = -30.1$ dB.
 7. Average value = peak reading + $20\log(\text{duty cycle})$.



A D T

EUT TEST CONDITION		MEASUREMENT DETAIL	
CHANNEL	Channel 39	FREQUENCY RANGE	1 ~ 25GHz
INPUT POWER (SYSTEM)	120Vac, 60Hz	DETECTOR FUNCTION	Peak (PK)
ENVIRONMENTAL CONDITIONS	19deg. C, 68%RH 1023 hPa	TESTED BY	Rex Huang

ANTENNA POLARITY & TEST DISTANCE: HORIZONTAL AT 3 M								
NO.	FREQ. (MHz)	EMISSION LEVEL (dBuV/m)	LIMIT (dBuV/m)	MARGIN (dB)	ANTENNA HEIGHT (m)	TABLE ANGLE (Degree)	RAW VALUE (dBuV)	CORRECTION FACTOR (dB/m)
1	*2441.00	105.4 PK			1.00 H	251	73.57	31.83
2	*2441.00	75.3 AV			1.00 H	251	43.47	31.83
3	4882.00	50.6 PK	74.0	-23.4	1.05 H	126	11.43	39.17
4	4882.00	20.5 AV	54.0	-33.5	1.05 H	126	-18.67	39.17
5	7323.00	54.3 PK	74.0	-19.7	1.43 H	164	7.67	46.63
6	7323.00	24.2 AV	54.0	-29.8	1.43 H	164	-22.43	46.63
ANTENNA POLARITY & TEST DISTANCE: VERTICAL AT 3 M								
NO.	FREQ. (MHz)	EMISSION LEVEL (dBuV/m)	LIMIT (dBuV/m)	MARGIN (dB)	ANTENNA HEIGHT (m)	TABLE ANGLE (Degree)	RAW VALUE (dBuV)	CORRECTION FACTOR (dB/m)
1	*2441.00	101.9 PK			1.00 V	66	70.07	31.83
2	*2441.00	71.8 AV			1.00 V	66	39.97	31.83
3	4882.00	51.3 PK	74.0	-22.7	1.05 V	69	12.13	39.17
4	4882.00	21.2 AV	54.0	-32.8	1.05 V	69	-17.97	39.17
5	7323.00	53.2 PK	74.0	-20.8	1.00 V	204	6.57	46.63
6	7323.00	23.1 AV	54.0	-30.9	1.00 V	204	-23.53	46.63

- REMARKS:**
1. Emission level (dBuV/m) = Raw Value (dBuV) + Correction Factor (dB/m).
 2. Correction Factor (dB/m) = Antenna Factor (dB/m) + Cable Factor (dB).
 3. The other emission levels were very low against the limit.
 4. Margin value = Emission level – Limit value.
 5. “ * “: Fundamental frequency.
 6. The DH5 packet was the worse case duty cycle for a transmit dwell time on a channel, based upon bluetooth theory the transmitter is on 0.625 * 5 per 296.25 ms per channel. Therefore, the duty cycle correlation factor be equal to: $20\log(3.125 / 100) = -30.1$ dB.
 7. Average value = peak reading + $20\log(\text{duty cycle})$.



A D T

EUT TEST CONDITION		MEASUREMENT DETAIL	
CHANNEL	Channel 78	FREQUENCY RANGE	1 ~ 25GHz
INPUT POWER (SYSTEM)	120Vac, 60Hz	DETECTOR FUNCTION	Peak (PK)
ENVIRONMENTAL CONDITIONS	19deg. C, 68%RH 1023 hPa	TESTED BY	Rex Huang

ANTENNA POLARITY & TEST DISTANCE: HORIZONTAL AT 3 M

NO.	FREQ. (MHz)	EMISSION LEVEL (dBuV/m)	LIMIT (dBuV/m)	MARGIN (dB)	ANTENNA HEIGHT (m)	TABLE ANGLE (Degree)	RAW VALUE (dBuV)	CORRECTION FACTOR (dB/m)
1	*2480.00	105.6 PK			1.00 H	251	73.65	31.95
2	*2480.00	75.5 AV			1.00 H	251	43.55	31.95
3	2483.50	56.3 PK	74.0	-17.7	1.00 H	251	24.33	31.97
4	2483.50	26.2 AV	54.0	-27.8	1.00 H	251	-5.77	31.97
5	4960.00	51.4 PK	74.0	-22.6	1.07 H	122	11.98	39.42
6	4960.00	21.3 AV	54.0	-32.7	1.07 H	122	-18.12	39.42
7	7440.00	54.2 PK	74.0	-19.8	1.45 H	173	7.64	46.56
8	7440.00	24.1 AV	54.0	-29.9	1.45 H	173	-22.46	46.56

ANTENNA POLARITY & TEST DISTANCE: VERTICAL AT 3 M

NO.	FREQ. (MHz)	EMISSION LEVEL (dBuV/m)	LIMIT (dBuV/m)	MARGIN (dB)	ANTENNA HEIGHT (m)	TABLE ANGLE (Degree)	RAW VALUE (dBuV)	CORRECTION FACTOR (dB/m)
1	*2480.00	101.0 PK			1.00 V	65	69.05	31.95
2	*2480.00	70.9 AV			1.00 V	65	38.95	31.95
3	2483.50	55.9 PK	74.0	-18.1	1.00 V	65	23.93	31.97
4	2483.50	25.8 AV	54.0	-28.2	1.00 V	65	-6.17	31.97
5	4960.00	51.9 PK	74.0	-22.1	1.05 V	71	12.48	39.42
6	4960.00	21.8 AV	54.0	-32.2	1.05 V	71	-17.62	39.42
7	7440.00	53.6 PK	74.0	-20.4	1.00 V	208	7.04	46.56
8	7440.00	23.5 AV	54.0	-30.5	1.00 V	208	-23.06	46.56

- REMARKS:**
- Emission level (dBuV/m) = Raw Value (dBuV) + Correction Factor (dB/m).
 - Correction Factor (dB/m) = Antenna Factor (dB/m) + Cable Factor (dB).
 - The other emission levels were very low against the limit.
 - Margin value = Emission level – Limit value.
 - * * *: Fundamental frequency.
 - The DH5 packet was the worse case duty cycle for a transmit dwell time on a channel, based upon bluetooth theory the transmitter is on 0.625 * 5 per 296.25 ms per channel. Therefore, the duty cycle correlation factor be equal to: $20\log(3.125 / 100) = -30.1$ dB.
 - Average value = peak reading + $20\log(\text{duty cycle})$.

RESTRICTED BANDEDGE (8DPSK MODE, CH0, HORIZONTAL)

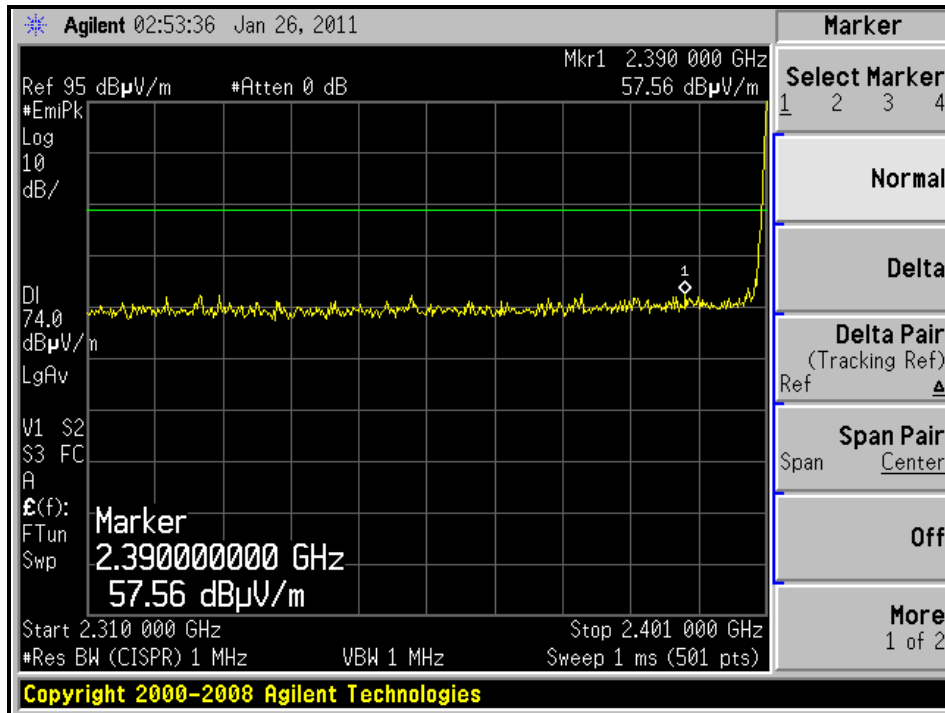

RESTRICTED BANDEDGE (8DPSK MODE, CH0, VERTICAL)

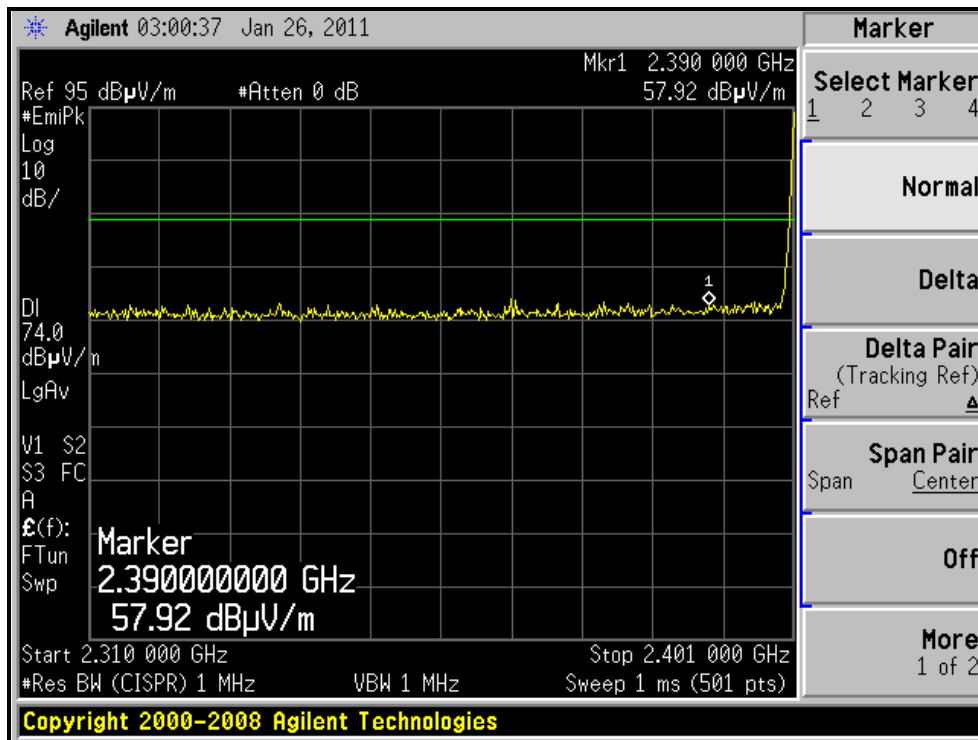

* The average value of fundamental frequency is: Average value = peak reading + 20log(duty cycle). And it meets the requirement of limit.

RESTRICTED BANDEDGE (8DPSK MODE, CH78, HORIZONTAL)

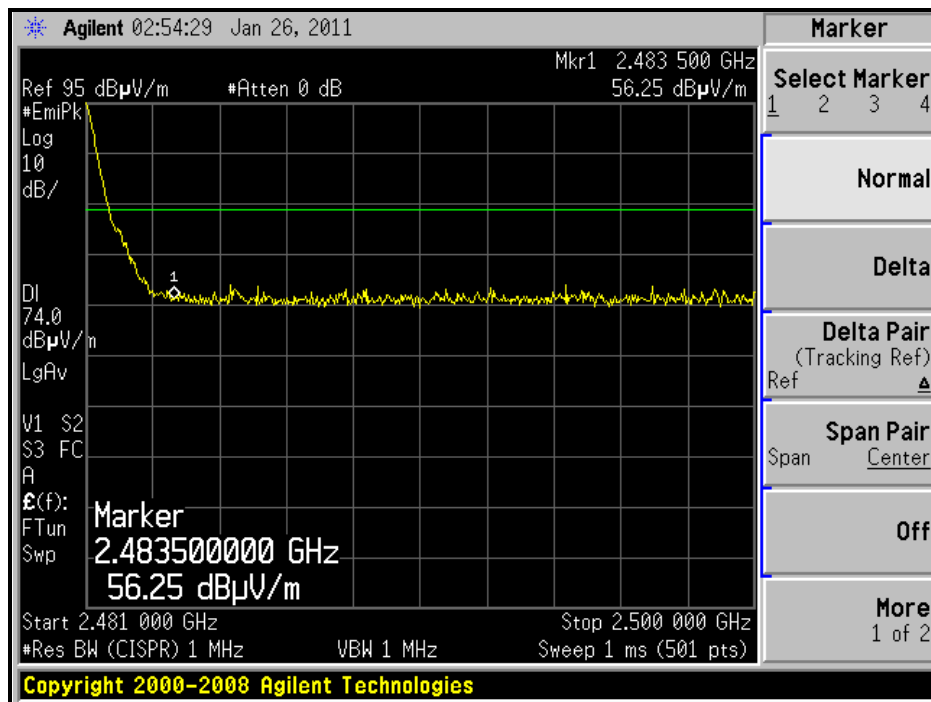

RESTRICTED BANDEDGE (8DPSK MODE, CH78, VERTICAL)

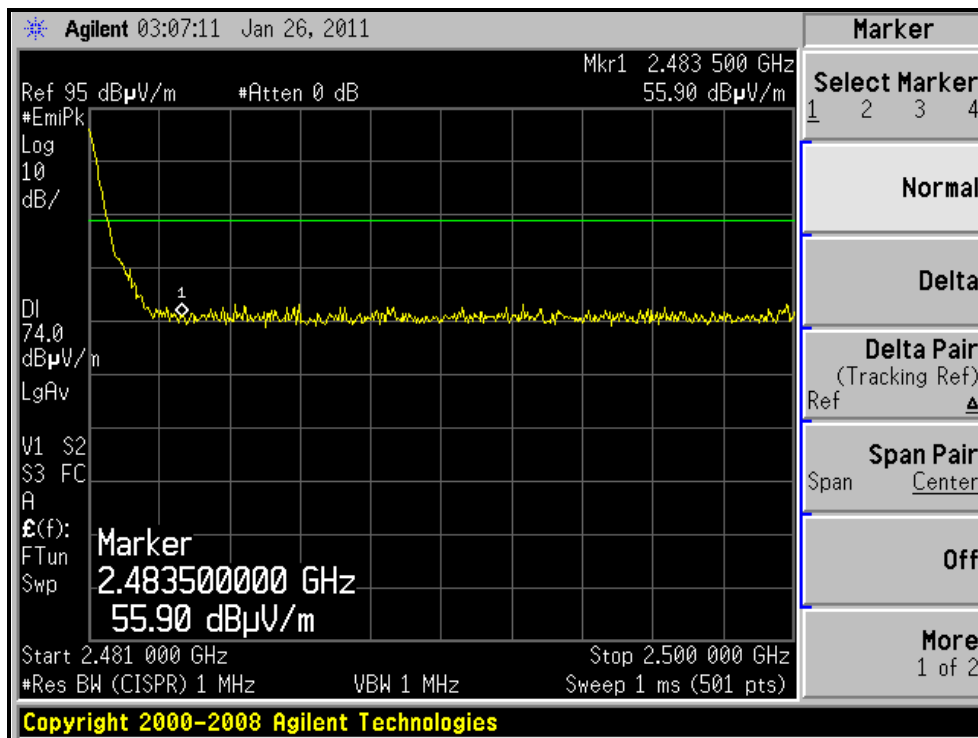

* The average value of fundamental frequency is: Average value = peak reading + 20log(duty cycle). And it meets the requirement of limit.

4.8 CONDUCTED OUT-BAND EMISSION MEASUREMENT

4.8.1 LIMITS OF CONDUCTED OUT-BAND EMISSION MEASUREMENT

Below -20dB of the highest emission level of operating band (in 100kHz RBW).

4.8.2 TEST INSTRUMENTS

DESCRIPTION & MANUFACTURER	MODEL NO.	SERIAL NO.	CALIBRATED DATE	CALIBRATED UNTIL
PSA Seviess Spectrum Analyzer	FSP40	100036	Dec. 08, 2010	Dec. 07, 2011

NOTE: The calibration interval of the above test instruments is 12 months and the calibrations are traceable to NML/ROC and NIST/USA.

4.8.3 TEST PROCEDURE

The transmitter output was connected to the spectrum analyzer via a low lose cable. Set RBW a of spectrum analyzer to 100 kHz and VBW of spectrum analyzer to 300 kHz with suitable frequency span including 100 MHz bandwidth from band edge. The band edges was measured and recorded.

4.8.4 DEVIATION FROM TEST STANDARD

No deviation

4.8.5 EUT OPERATING CONDITION

The software provided by client enabled the EUT to transmit and receive data at lowest, middle and highest channel frequencies individually.

4.8.6 TEST RESULTS

For GFSK Modulation Type:

CH0

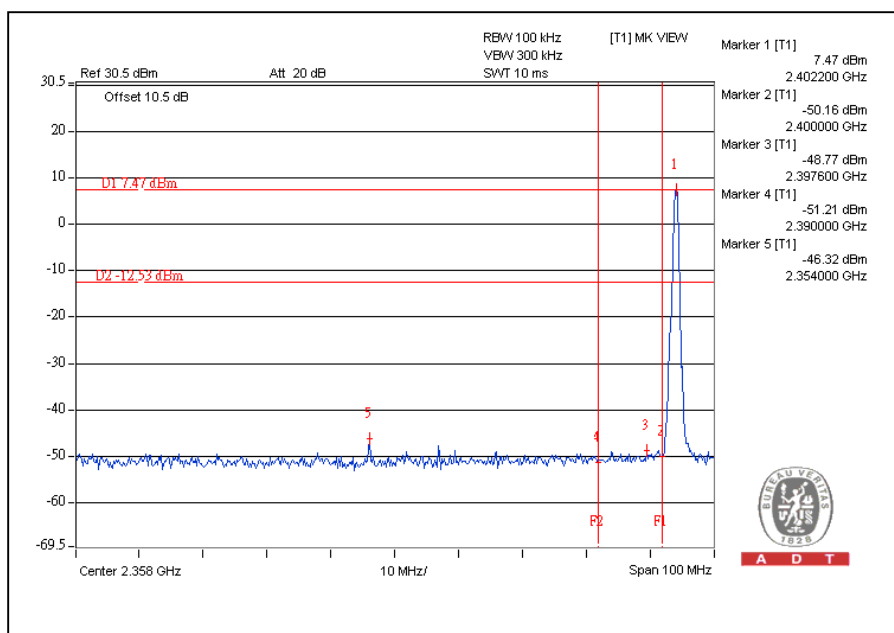

CH78

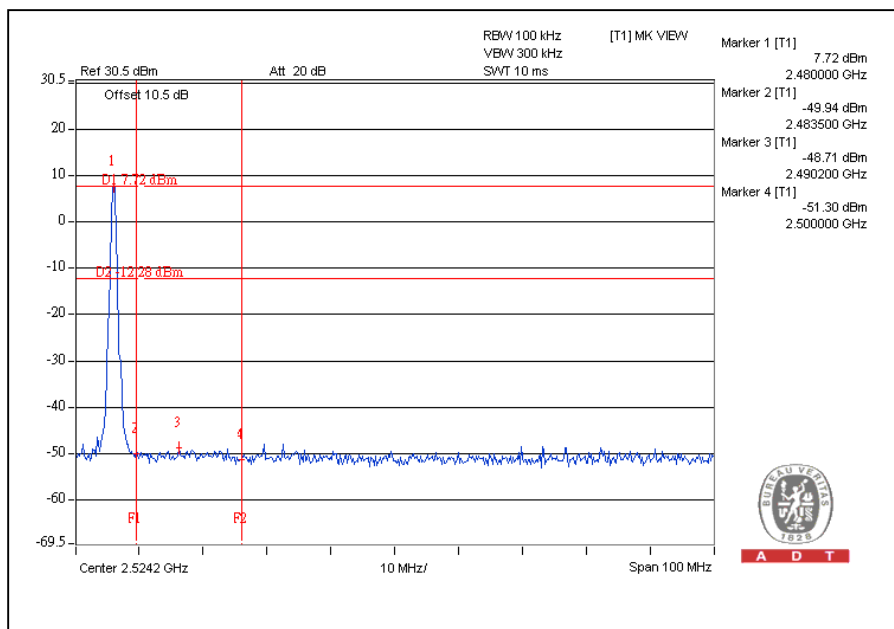



A D T

CH0

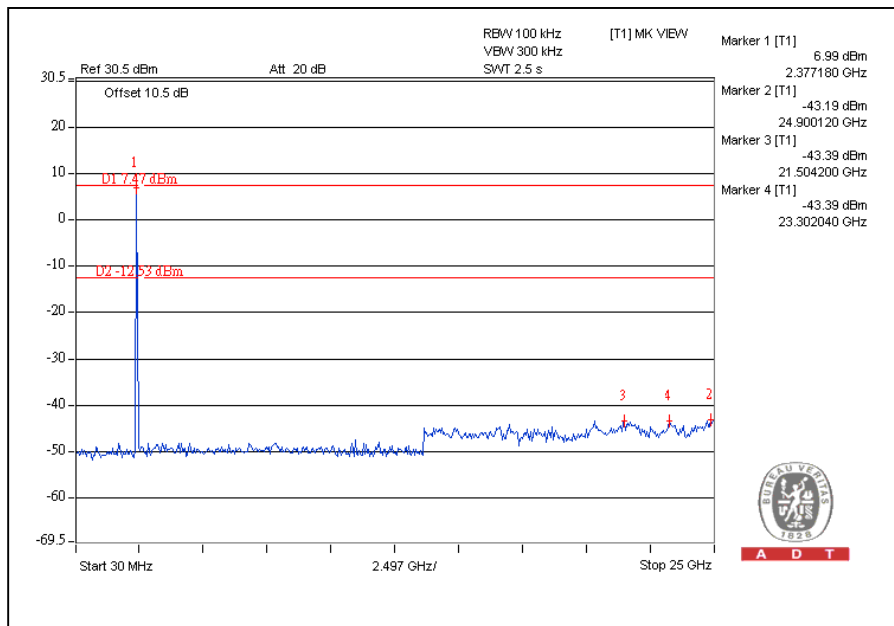

A D T

CH78

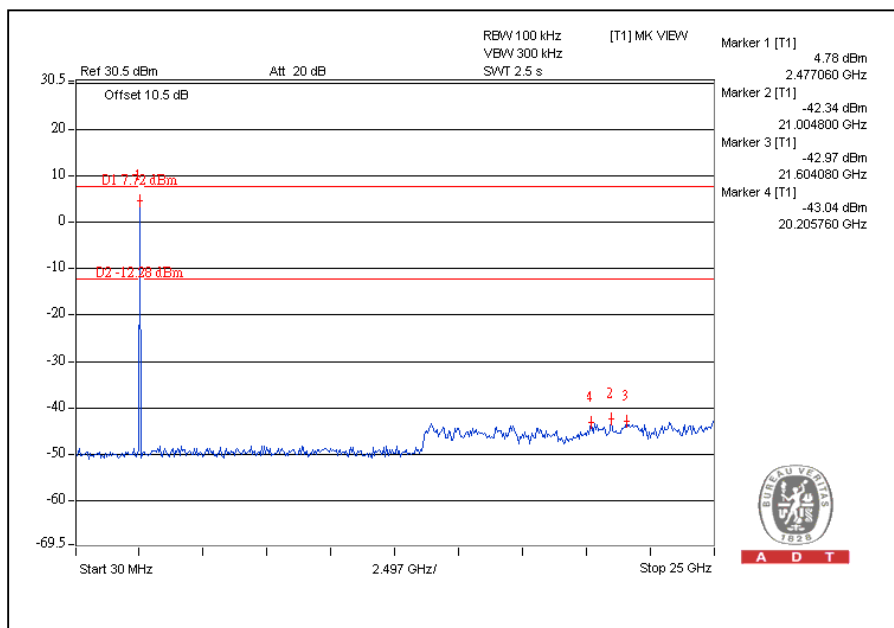

A D T



A D T

For 8DPSK Modulation Type:

CH0

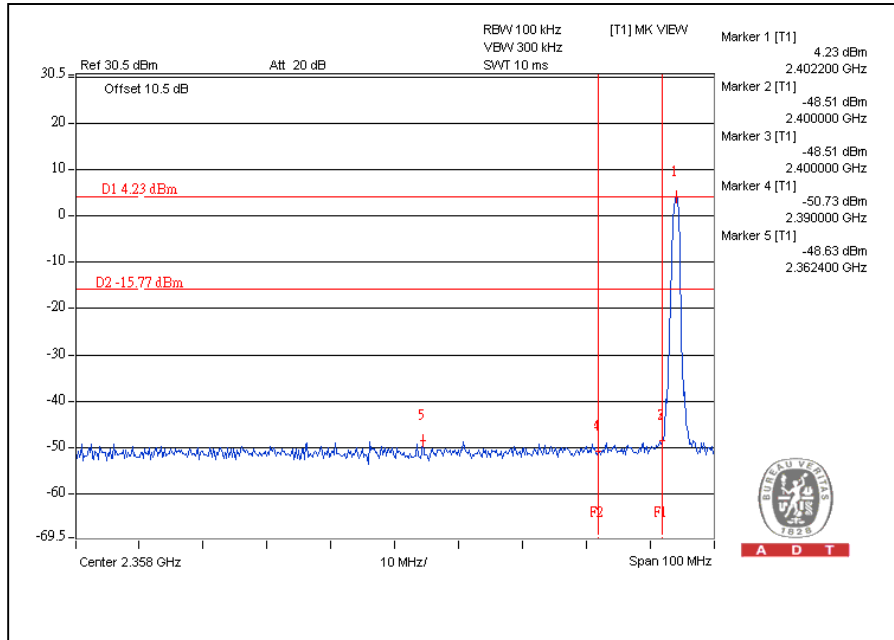

CH78

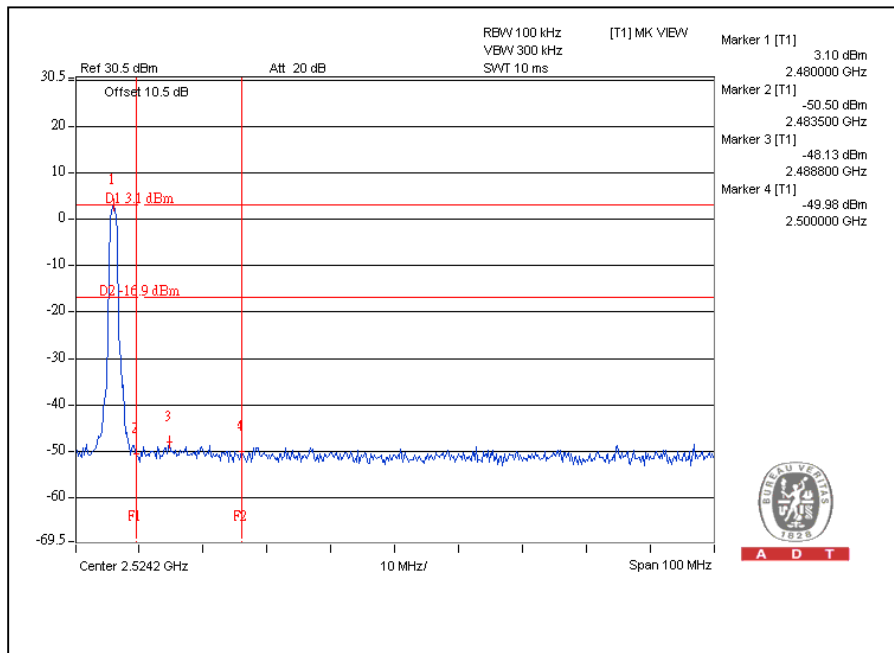



5 INFORMATION ON THE TESTING LABORATORIES

We, Bureau Veritas Consumer Products Services (H.K.) Ltd., Taoyuan Branch, were founded in 1988 to provide our best service in EMC, Radio, Telecom and Safety consultation. Our laboratories are accredited and approved according to ISO/IEC 17025:

Copies of accreditation certificates of our laboratories obtained from approval agencies can be downloaded from our web site: www.adt.com.tw/index.5.phtml.
If you have any comments, please feel free to contact us at the following:

Linko EMC/RF Lab:

Tel: 886-2-26052180

Fax: 886-2-26052943

Hsin Chu EMC/RF Lab:

Tel: 886-3-5935343

Fax: 886-3-5935342

Hwa Ya EMC/RF/Safety/Telecom Lab:

Tel: 886-3-3183232

Fax: 886-3-3185050

Email: service@adt.com.tw

Web Site: www.adt.com.tw

The address and road map of all our labs can be found in our web site also.

6 APPENDIX A - MODIFICATIONS RECORDERS FOR ENGINEERING CHANGES TO THE EUT BY THE LAB

No any modifications are made to the EUT by the lab during the test.

--- END ---