

List of Contents	Page
1. Description of Equipment Under Test	4
1.1 Product Description	4
1.2 Antenna Description	4
2. General Information	5
2.1 Test Methodology	5
2.2 Test Facility	5
2.3 Tractability	5
3. Summary of Test Results	5
4. Test Configuration	6
4.1 Conducted Emission Measurement	6
4.2 Radiated Measurement in 3m Anechoic Chamber	6
4.3 Test Mode	7
5. Measurement Result	8
5.1 15. 207 AC Power Conducted Emission	8
5.1.1 Setting Remarks	8
5.1.2 Minimum Standard	8
5.1.3 Result	8
5.1.4 Measured Data	9
5.2 15. 209 Transmitter Radiated Emissions	11
5.2.1 Setting Remarks	11
5.2.2 Minimum Standard	12
5.2.3 Result	12
5.2.4 Measured Data	13
5.3 Maximum Carrier Output Power	15
5.3.1 Setting Remarks	15
5.3.2 Minimum Standard	15
5.3.3 Result	15
5.3.4 Measured Data	16
5.4 Frequency Tolerance	18
5.4.1 Setting Remarks	18
5.4.2 Minimum Standard	18
5.4.3 Result	18
5.4.4 Measured Data	18
6. Photos	19
6.1 Setup Photo (Conducted Emission)	19
6.2 Setup Photo (Radiated Emission)	20
7. List of Test Measurement Instruments	22

7.1 Conducted Emission Measurement.....22
7.2 Radiated Emission Measurement.....22

2. General Information

2.1 Test Methodology

All measurement subject to the present test report is carried out according to the procedures in ANSI C63.4:2003.

2.2 Test Facility

All measurement was performed in the following facility;

Cosmos Corporation EMC Lab. Ohnogi

(2-3571 Ohaza-iwatachi, Ohnogi, Watarai-cho, Watarai-gun, Mie-ken 516-2102, Japan) This site has been accepted in a letter dated November 2, 2004 from FCC.

2.3 Tractability

The calibration of measurement equipment used in the test subject to the present report is designed and operated to ensure that the measurement is traceable to national standards of measurement or equivalent abroad.

3. Summary of Test Results

Section	Test Item	Limit	Result
15. 207	AC Power Conducted Emission	Limit: min.48dBuV	Pass
15. 209	Field Strength of Spurious Emission	Refer to 15. 209	Pass
15. 225	Maximum Output Power	15,848 uV/m @ 30 m	Pass
15. 225	Frequency Tolerance	± 0.01 %	Pass

4. Test Configuration

4.1 Conducted Emission Measurement

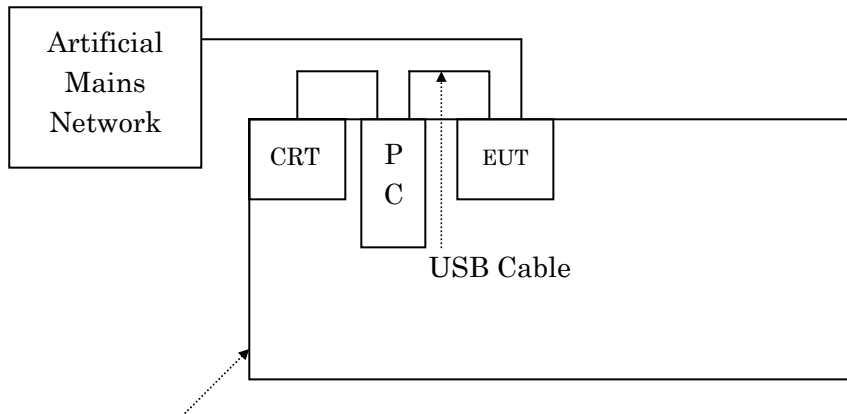

Non-conductive table, 0.8m high
Non-conductive board, 12mm thick

4.2 Radiated Measurement in 3m Anechoic Chamber

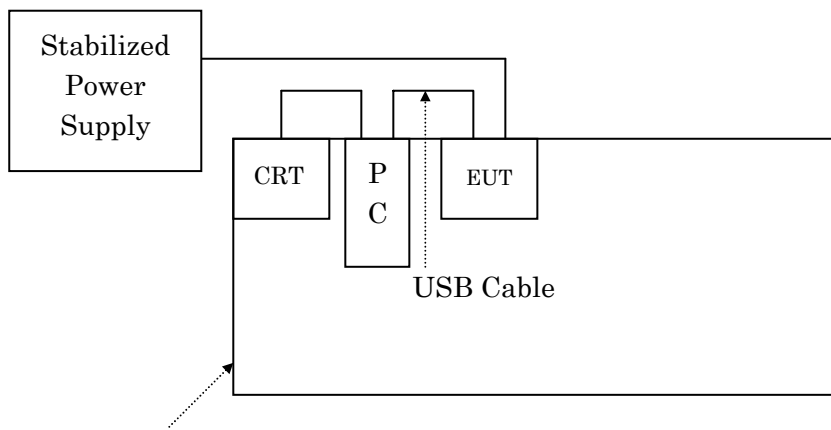

Non-conductive table, 0.8m high
Non-conductive board, 12mm thick

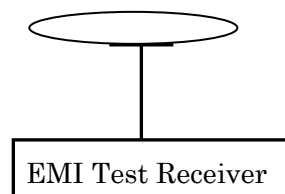

Antenna (Loop, Biconical and Log-periodic)

4.3 Test Mode

In all test configurations above, EUT makes communication link between the integrated RFID module and a RFID tag in a dedicated ink ribbon with the maximum RF power by a special test program.

Maximum Output Power and Frequency Tolerance measurement were performed with an external stabilized AC power supply voltage varied between 85% and 115% of the nominal rated supply voltage 120 VAC.

Frequency Tolerance measurement is performed under the following extreme condition:

Temperature: - 20°C to +50°C (120 VAC)

Voltage: 102 to 138 VAC (Normal temperature)

5. Measurement Result

5.1 15. 207 AC Power Conducted Emission

5.1.1 Setting Remarks

- Configure the EUT System in accordance with ANSI C63.4-2003.
- A wooden test table (1.5m×1.0m, height 0.8m) was used.
- EUT's dedicated AC adapter connected to Artificial Mains Network (AMN).
- Other power cord of support equipment is connected to another AMN to isolate its emission from the measured emission of EUT.
- The measuring port of AMN for support equipment was terminated by the 50Ω
- Activate the EUT System and run the software prepared for the test, if necessary.
- Refer to test configuration figure 4.1.

5.1.2 Minimum Standard

(a) Except as shown in paragraphs (b) and (c) of this section, for an intentional radiator that is designed to be connected to the public utility (AC) power line, the radio frequency voltage that is conducted back onto the AC power line on any frequency or frequencies within the band 150 kHz to 30 MHz shall not exceed the limits in the following table, as measured using a 50 μH/50 ohms line impedance stabilization network (LISN). Compliance with the provisions of this paragraph shall be based on the measurement of the radio frequency voltage between each power line and ground at the power terminal. The lower limit applies at the boundary between the frequency ranges.

Frequency of Emission (MHz)	Conducted Limit (dBuV)	
	Quasi-peak	Average
0.15-0.5	66 to 56 *	56 to 46 *
0.5-5	56	46
5-30	60	50

* Decreases with the logarithm of the frequency.

5.1.3 Result

EUT complies with the requirement.

Uncertainty of measurement : ± 2.26 dB
 Temperature, Humidity : 20 °C, 40 %

5.1.4 Measured Data

Measured Value Table

Model Name : DS80
 Serial No. :
 Operator : T. Tanaka
 Power Supply : AC120V, 60Hz
 Job No : CJ06-056906E
 Temp/Humi : 20°C/44%
 Condition : Operated
 Remark :
 Memo :

LIMIT : FCC Part.15 Class B QP
 FCC Part.15 Class B AV

No	Freq. [MHz]	Reading Level		C. Fac [dB]	Results		Limit		Margin		Phase	Comment
		QP	AV		QP	AV	QP	AV	QP	AV		
		[dBuV]	[dBuV]		[dBuV]	[dBuV]	[dBuV]	[dBuV]	[dB]	[dB]		
1	0.15663	47.5	40.2	10.7	58.2	50.9	65.6	55.6	7.4	4.7	La	
2	0.21035	34.1	28.0	10.4	44.5	38.4	63.2	53.2	18.7	14.8	La	
3	4.83780	23.6	21.7	10.6	34.2	32.3	56.0	46.0	21.8	13.7	La	
4	5.51980	24.3	21.2	10.7	35.0	31.9	60.0	50.0	25.0	18.1	La	
5	6.33412	27.8	25.4	10.6	38.4	36.0	60.0	50.0	21.6	14.0	La	
6	8.12414	23.9	23.9	10.8	34.7	34.7	60.0	50.0	25.3	15.3	La	
7	0.15705	47.5	40.2	10.7	58.2	50.9	65.6	55.6	7.4	4.7	Lb	
8	0.20855	33.7	27.6	10.4	44.1	38.0	63.3	53.3	19.2	15.3	Lb	
9	4.97169	23.5	23.5	10.6	34.1	34.1	56.0	46.0	22.0	11.9	Lb	
10	6.14151	30.7	24.6	10.7	41.4	35.3	60.0	50.0	18.6	14.7	Lb	
11	6.57492	26.8	25.0	10.7	37.5	35.7	60.0	50.0	22.5	14.3	Lb	
12	8.17097	24.8	23.8	10.8	35.6	34.6	60.0	50.0	24.4	15.4	Lb	

Peak Hold Wave Form

Model Name	: DS80	Job No	: CJ06-056906E
Serial No.	:	Temp/Humi	: 20°C/44%
Operator	: T. Tanaka	Condition	: Operated
Power Supply	: AC120V, 60Hz	Remark	:
Memo	:		

LIMIT : FCC Part. 15 Class B QP
FCC Part. 15 Class B AV

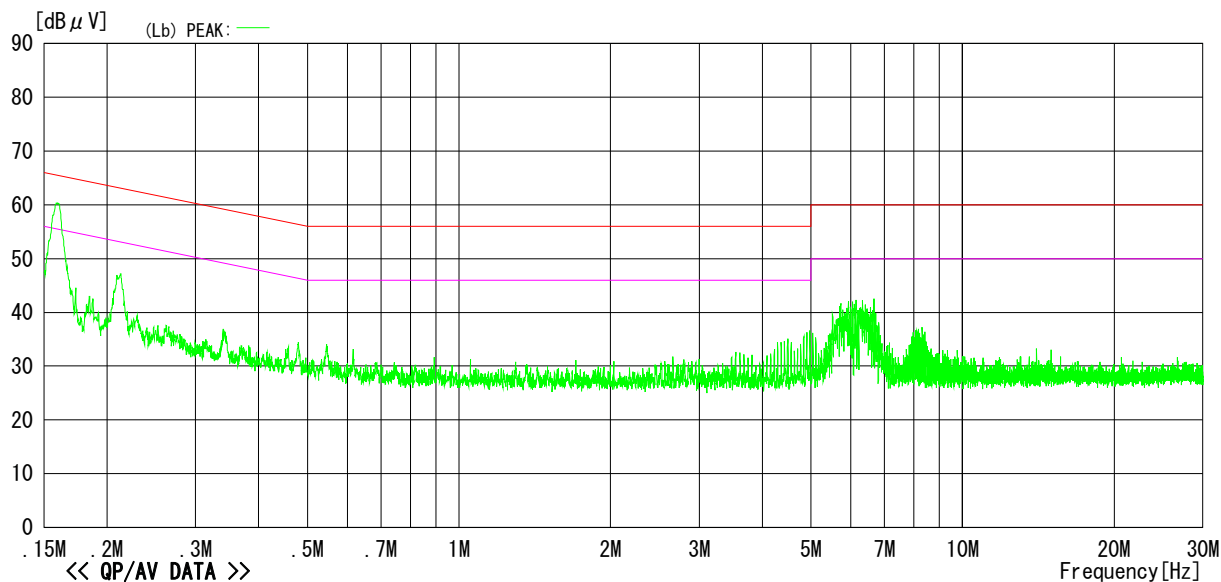
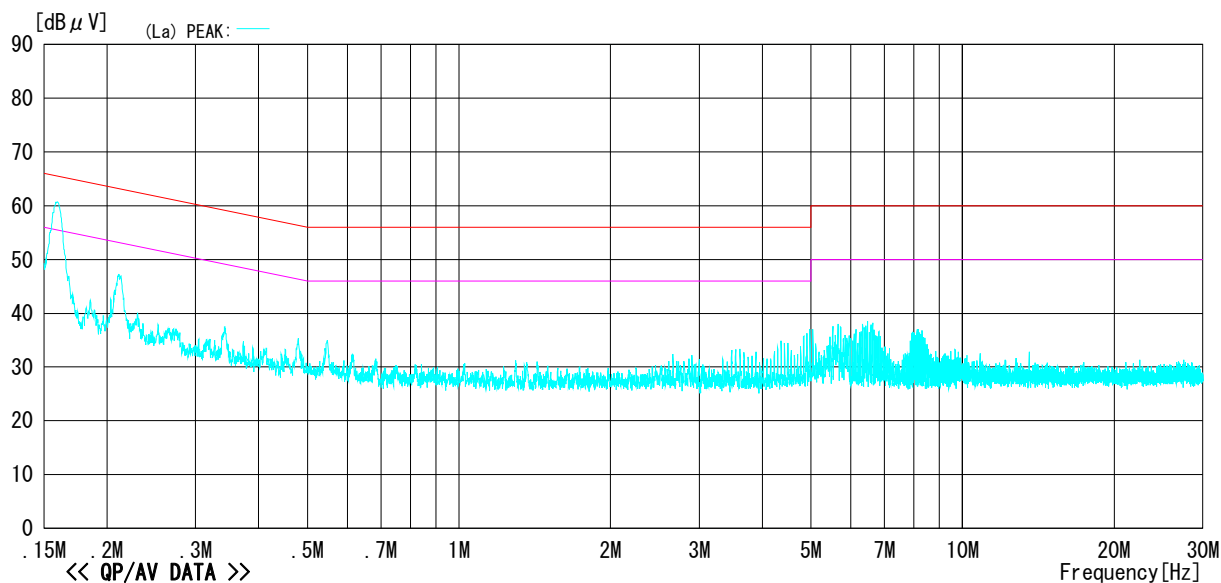

5.2 15. 209 Transmitter Radiated Emissions

5.2.1 Setting Remarks

- The data lists in “5.2.4 Measured Data “ list the significant emission frequencies, measured levels, correction factor (includes cable and antenna corrections), the corrected reading, plus the limit.
- In the frequency range between 9kHz to 1 GHz, the Electric Field Strength was measured in accordance with ANSI C63.4: 2003 and CISPR22: 1997.
- The test setup was made in accordance with ANSI C63.4: 2003.
- The antenna was measured at 1-4m height for 30MHz to 1GHz.
- The EUT was placed on the non-conductive table in the center of turntable. The height of this table was 0.8m.
- The measurement was carried out with both horizontal and vertical antenna polarization.
- The highest radiation from the equipment was recorded.
- Below 30MHz, a loop antenna was used at 1m height.
- By varying the configuration of the test sample and the cable routing, it was attempted to maximize the emission.
- The test receiver with Quasi Peak and Average detector is in compliance with CISPR 16-1:1993.
- 9-90 kHz, 110-490 kHz are based on measurements employing an average detector.
- The spectrum analyzer was set-up as following;

(Frequency range : 9kHz - 30 MHz)

- ✓ Resolution bandwidth : 10 kHz
- ✓ Video bandwidth : 100 kHz
- ✓ Detector function : Peak
- ✓ Trace Mode : Max Hold

(Frequency range : 30 - 1000 MHz)

- ✓ Resolution bandwidth : 100 kHz
- ✓ Video bandwidth : 300 kHz
- ✓ Detector function : Peak
- ✓ Trace Mode : Max Hold

- EMI Test Receiver analyzer was set-up as following (Quasi-Peak Detector);

- ✓ IF bandwidth : 200 Hz (9kHz - 150kHz)
- ✓ IF bandwidth : 9 kHz (150kHz - 30MHz)
- ✓ IF bandwidth : 120 kHz (30MHz - 1GHz)

- Refer to test configuration figure 4.2.

5.2.2 Minimum Standard

(d) The field strength of any emissions appearing outside of the 13.110-14.010 MHz band shall not exceed the general radiated emission limits in § 15.209.

5.2.3 Result

EUT complies with the requirement.

Uncertainty of measurement result: ± 3.64 dB

Temperature, Humidity : Refer to each data table

5.2.4 Measured Data

9kHz to 30MHz

Model Name	: DS80	Job No.	: CJ06-056906E
Serial No.	: CS-869	Temp./Humi.	: 24°C/34%
Operator	: D. Watanuki	Condition	: Operated
Power Supply	: 120VAC / 60Hz	Remark	: 3m distance

Memo : RFID operation mode

LIMIT : FCC Part15 SubpartC 15.209 9KHz-30MHz

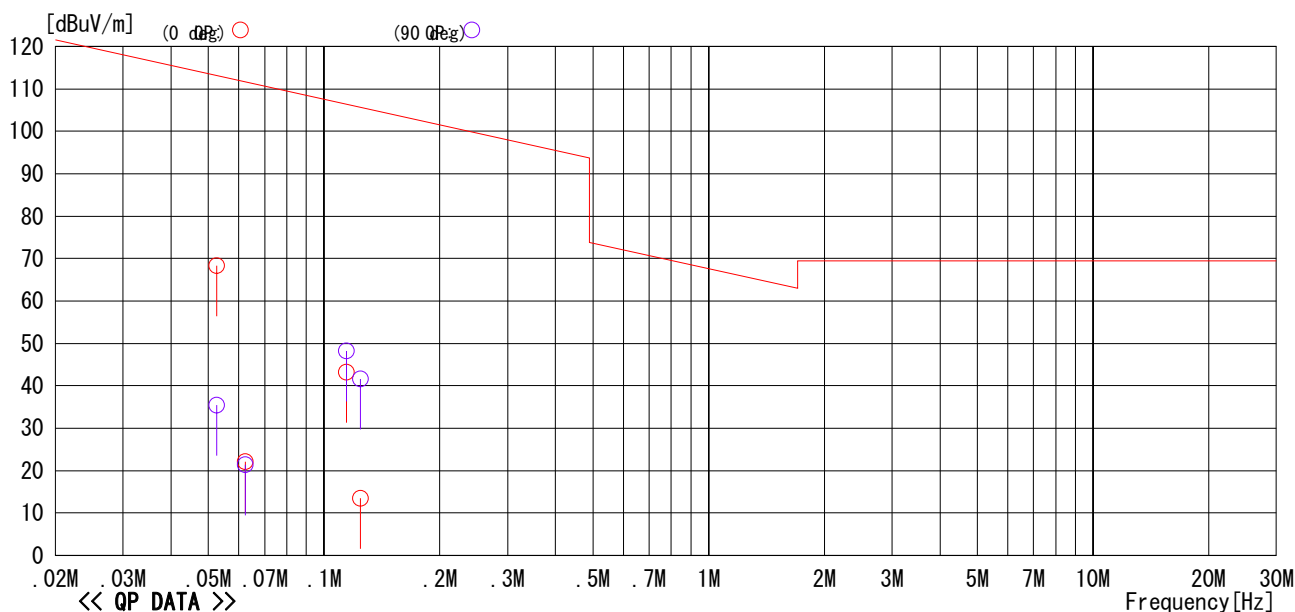

No	Freq.	Reading	Ant. Fac	Loss	Result	Limit	Margin	Antenna	Angle
	[MHz]	[dBuV]	[dB/m]	[dB]	[dBuV/m]	[dBuV/m]	[dB]		[deg]
1	0.05251	49.3	19.0	0.0	68.3	113.2	44.9	0deg	170
2	0.06244	3.1	19.0	0.0	22.1	111.7	89.6	0deg	79
3	0.11439	24.1	19.0	0.1	43.2	106.4	63.2	0deg	107
4	0.12456	-5.6	19.0	0.1	13.5	105.7	92.2	0deg	104
5	0.05261	16.4	19.0	0.0	35.4	113.2	77.8	90deg	115
6	0.06237	2.4	19.0	0.0	21.4	111.7	90.3	90deg	156
7	0.11443	29.1	19.0	0.1	48.2	106.4	58.2	90deg	165
8	0.12435	22.6	19.0	0.1	41.7	105.7	64.0	90deg	183

30MHz to 1GHz

Model Name : DS80
 Serial No. : CS-869
 Operator : D. Watanuki
 Power Supply : AC120VAC / 60Hz

Job No : GJ06-056906E
 Temp./Humi. : 21°C/42%
 Condition : Operated
 Remark :

Memo : RFID operation mode

LIMIT : FCC 15.209 3m

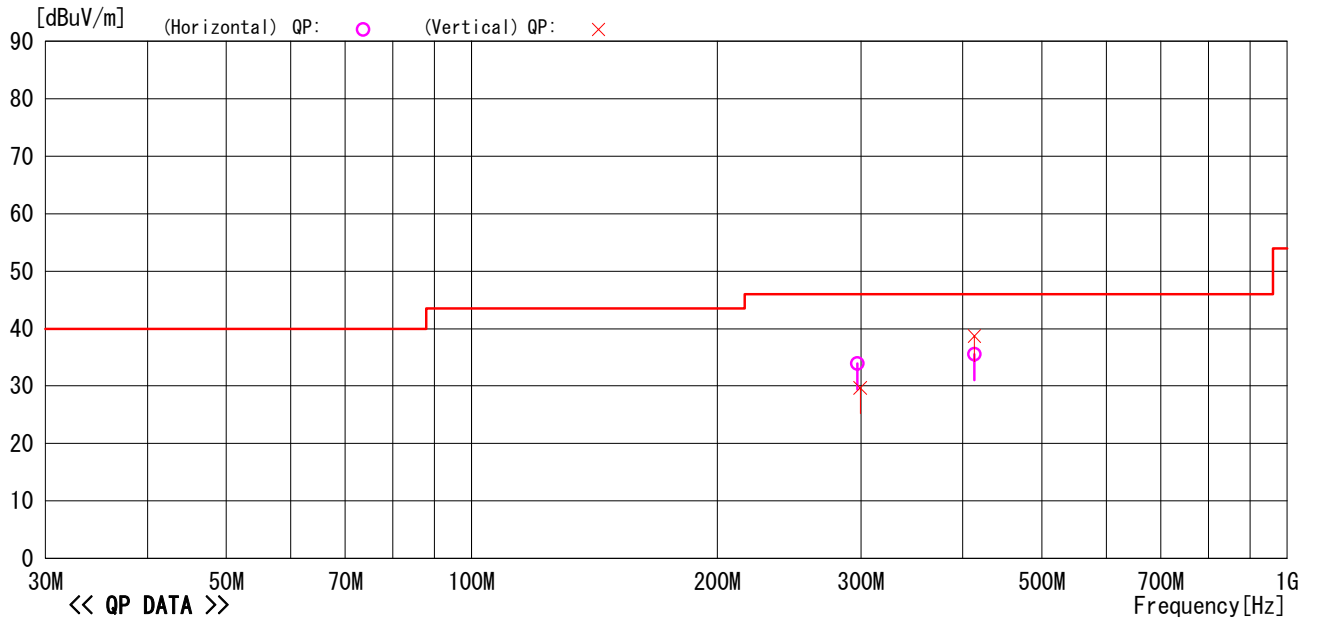

No	Freq.	Reading	C. Fac	Result	Limit	Margin	Pola.	Height	Angle	Ant	Comment
	[MHz]	[dBuV]	[dB/m]	[dBuV/m]	[dBuV/m]	[dB]	[H/V]	[cm]	[deg]	Type	
1	296.914	36.3	-2.4	33.9	46.0	12.1	Hori.	106	256	BC	
2	413.450	40.7	-5.2	35.5	46.0	10.5	Hori.	159	211	LP	
3	299.597	31.8	-2.1	29.7	46.0	16.3	Vert.	286	52	BC	
4	413.452	43.9	-5.2	38.7	46.0	7.3	Vert.	210	194	LP	

5.3 Maximum Carrier Output Power

5.3.1 Setting Remarks

- Refer to 5.2.1
- The EUT was placed on the non-conductive table in the center of turntable. The height of this table was 1m.
- The measurement was carried out with both horizontal and vertical antenna polarization.
- The highest radiation from the equipment was recorded.
- The test receiver with Quasi Peak and Average detector is in compliance with CISPR 16-1:1993.
- The spectrum analyzer was set-up as following;
 - ✓ Frequency Span : Appropriate to determine carrier frequency.
 - ✓ Resolution bandwidth : Appropriate to determine carrier frequency.
 - ✓ Video bandwidth : Appropriate to determine carrier frequency.
 - ✓ Sweep : Auto
 - ✓ Detector function : Peak
 - ✓ Trace Mode : Max Hold
- EMI Test Receiver analyzer was set-up as following (Quasi-Peak Detector);
 - ✓ IF bandwidth : 9 kHz
- Refer to test configuration figure 4.2.

5.3.2 Minimum Standard

- (a) The field strength of any emissions within the band 13.553-13.567 MHz shall not exceed 15,848 microvolts/meter at 30 meters.
- (b) Within the bands 13.410-13.553 MHz and 13.567-13.710 MHz, the field strength of any emissions shall not exceed 334 microvolts/meter at 30 meters.
- (c) Within the bands 13.110-13.410 MHz and 13.710-14.010 MHz the field strength of any emissions shall not exceed 106 microvolts/meter at 30 meters.

5.3.3 Result

EUT complies with the requirement.

Uncertainty of measurement result: ± 3.64 dB
 Temperature, Humidity : 25 °C, 34%

5.3.4 Measured Data (3m distance)

(102 VAC)

Frequency (MHz)	Polarization (°)	Correction Factor (dB)	Reading (dBuV)	Peak Power (dBuV/m)	Limit (dBuV/m)	Margin (dB)
13.11	0	18.5	4.26	22.76	80.5	57.74
13.41	0	18.4	4.26	22.66	80.5	57.84
13.553	0	18.4	4.26	22.66	90.47	67.81
13.560	0	18.4	8.24	26.64	124	97.36
13.567	0	18.4	3.98	22.38	90.47	68.09
13.71	0	18.4	3.98	22.38	80.5	58.12
14.01	0	18.4	3.98	22.38	80.5	58.12

(120 VAC)

Frequency (MHz)	Polarization (°)	Correction Factor (dB)	Reading (dBuV)	Peak Power (dBuV/m)	Limit (dBuV/m)	Margin (dB)
13.11	0	18.5	3.98	22.48	80.5	58.02
13.41	0	18.4	4.26	22.66	80.5	57.84
13.553	0	18.4	4.26	22.66	90.47	67.81
13.560	0	18.4	8.24	26.64	124	97.36
13.567	0	18.4	4.26	22.66	90.47	67.81
13.71	0	18.4	3.98	22.38	80.5	58.12
14.01	0	18.4	3.98	22.38	80.5	58.12

(138 VAC)

Frequency (MHz)	Polarization (°)	Correction Factor (dB)	Reading (dBuV)	Peak Power (dBuV/m)	Limit (dBuV/m)	Margin (dB)
13.11	0	18.5	4.26	22.76	80.5	57.74
13.41	0	18.4	4.26	22.66	80.5	57.84
13.553	0	18.4	4.26	22.66	90.47	67.81
13.560	0	18.4	8.24	26.64	124	97.36
13.567	0	18.4	4.26	22.66	90.47	67.81
13.71	0	18.4	4.26	22.66	80.5	57.84
14.01	0	18.4	4.26	22.66	80.5	57.84

* Correction Factor = Cable Loss (dB) + Antenna Factor (dB)

Carrier Spectrum

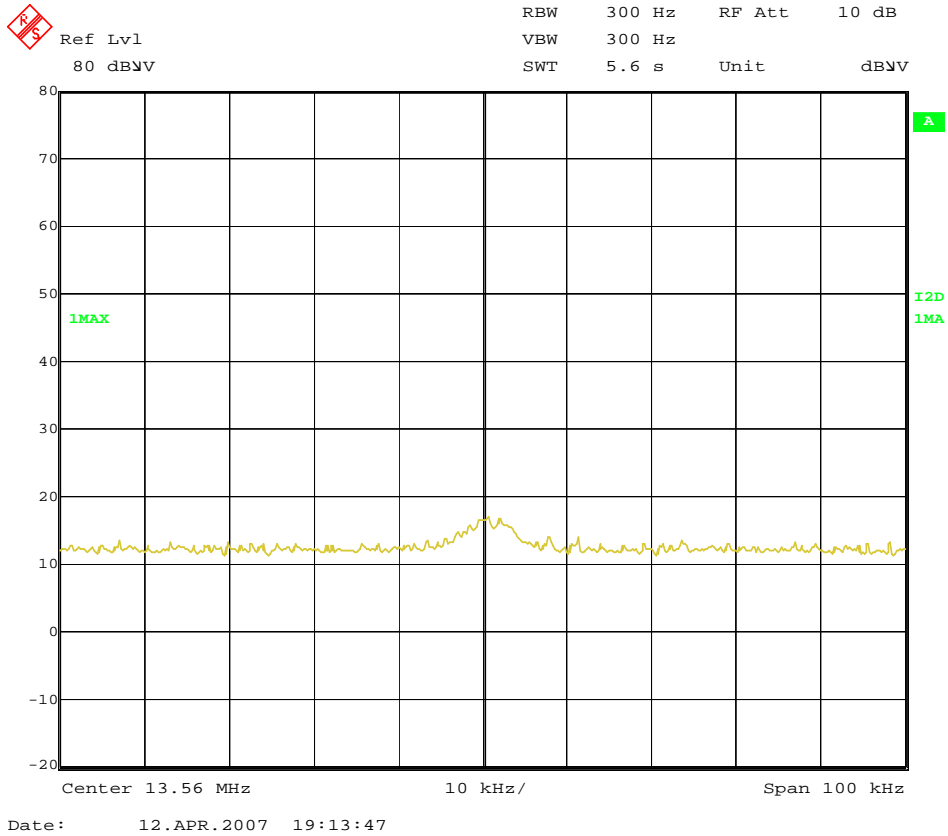

5.4 Frequency Tolerance

5.4.1 Setting Remarks

- Refer to setting remarks 5.3.1.
- Refer to test configuration figure 4.2.
- With an environmental test chamber, EUT is exposed in extreme temperatures until its temperature is stabilized. (Approximately 30 minutes) Then EUT is on with nominal AC voltage, or installed a fully charged battery.

5.4.2 Minimum Standard

(e) The frequency tolerance of the carrier signal shall be maintained within +/- 0.01% of the operating frequency over a temperature variation of -20 degrees to +50 degrees C at normal supply voltage, and for a variation in the primary supply voltage from 85% to 115% of the rated supply voltage at a temperature of 20 degrees C. For battery operated equipment, the equipment tests shall be performed using a new battery.

5.4.3 Result

EUT complies with the requirement.

Uncertainty of measurement result: ± 1 Hz

5.4.4 Measured Data

Temp. (°C)	P/S Voltage (VAC)	Frequency (Hz)	Limit (±Hz)	Offset from the CF (Hz)	Limit (%)	Error (%)
Center Freq.		13,560,000				
26	102.00	13,559,960	1356.00	-40	0.01	0.000
26	120.00	13,559,960	1356.00	-40	0.01	0.000
26	138.00	13,559,960	1356.00	-40	0.01	0.000
-20	102.00	13,559,900	1356.00	-100	0.01	-0.001
-20	120.00	13,560,150	1356.00	150	0.01	0.001
-20	138.00	13,559,980	1356.00	-20	0.01	0.000
50	102.00	13,560,540	1356.00	540	0.01	0.004
50	120.00	13,560,630	1356.00	630	0.01	0.005
50	138.00	13,560,680	1356.00	680	0.01	0.005

6. Photos

6.1 Setup Photo (Conducted Emission)

Front View



Side View



6.2 Setup Photo (Radiated Emission)

Front View (9kHz - 30MHz)

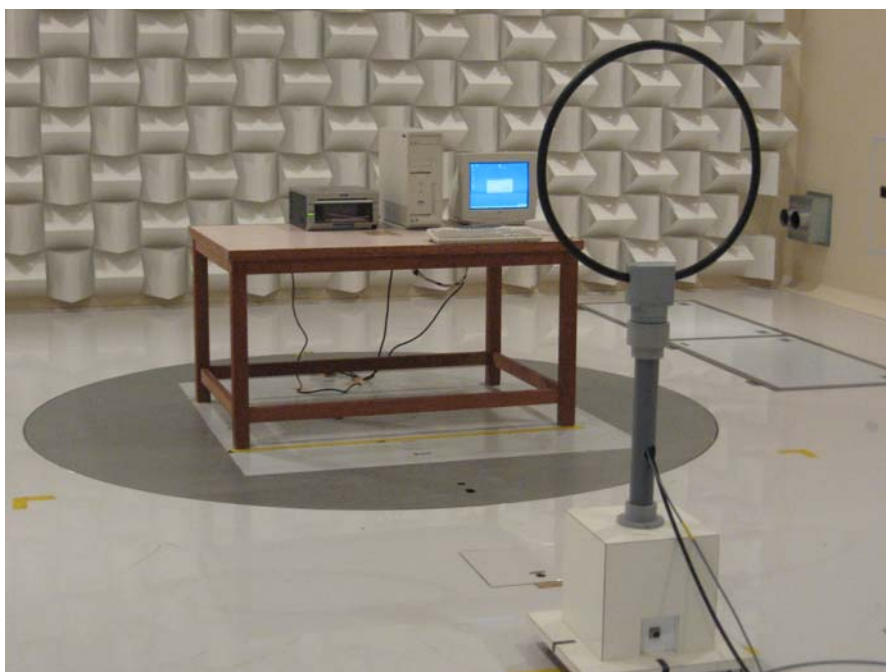

Rear View (9kHz - 30MHz)

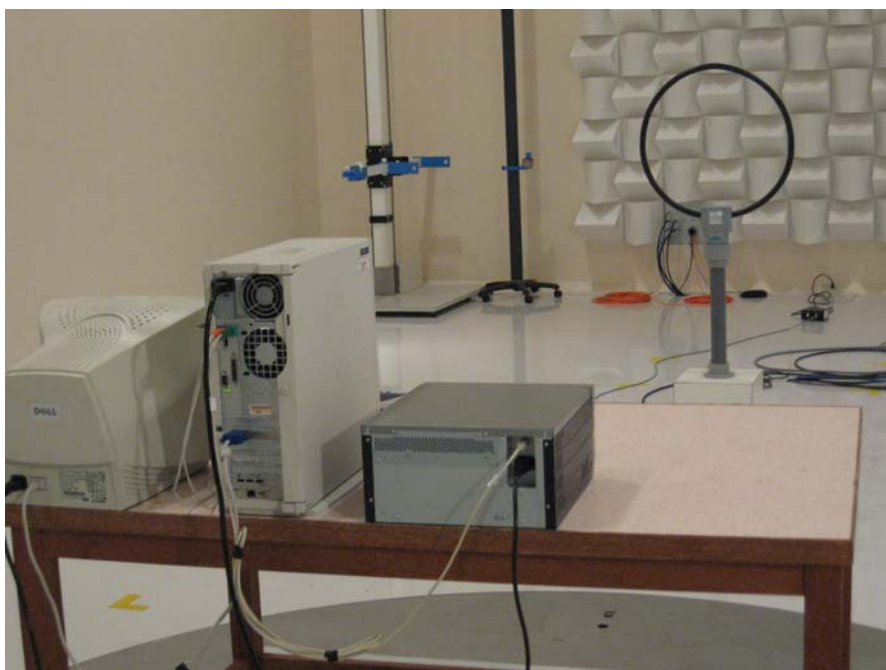

Front View (Above 30MHz)

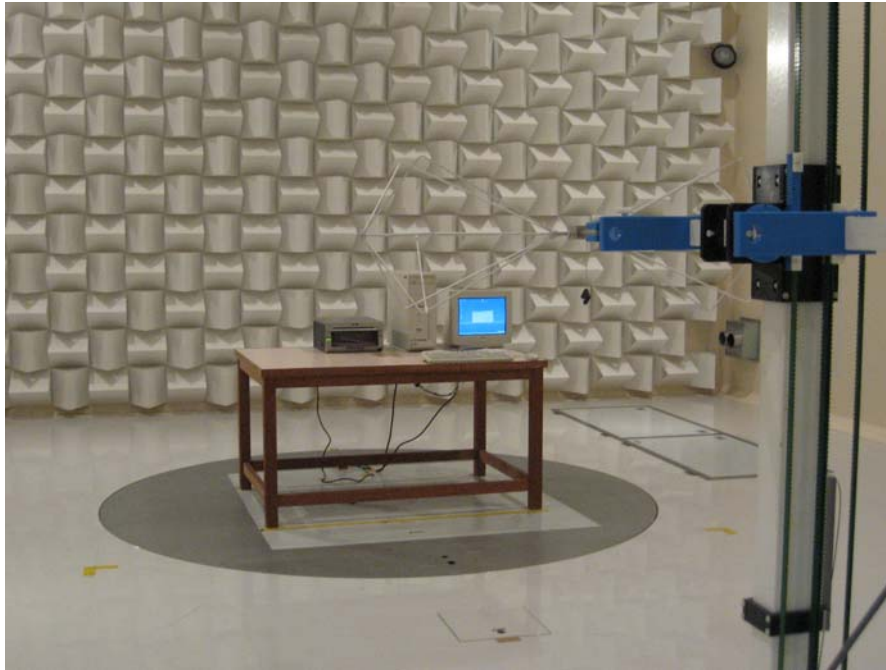

Rear View (Above 30MHz)

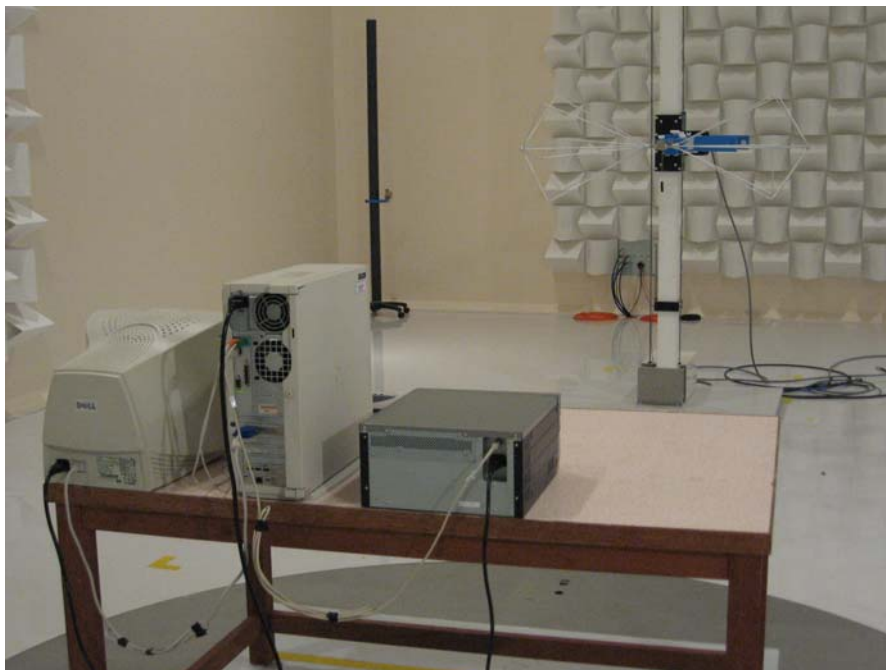

7. List of Test Measurement Instruments

7.1 Conducted Emission Measurement

Instruments	Manufacturer	Model / Type	Serial No.	Calibration Date Next Calibration
Spectrum Analyzer	ROHDE & SCHWARZ	FSA	828100/005 827831/007	July, 2006 July, 2007
EMI Test Receiver	ROHDE & SCHWARZ	ESHS10	842121/012	July, 2006 July, 2007
Artificial-Mains Network	ROHDE & SCHWARZ	ESH2-Z5 (for EUT)	842210/010	May, 2006 May, 2007
Artificial-Mains Network	CHASE Electronics Limited	MN2050B (for peripheral)	1140	June, 2006 June, 2007
RF cable	SCHAFFNER	RG214/U 50Ω	(4m)	May, 2006 May, 2007
RF Selector	TOYO Corporation	NS4906A	9601008	--
Transient Limiter	CHASE Electronics Limited	CFL9206	1426	--

7.2 Radiated Emission Measurement

Instruments	Manufacturer	Model / Type	Serial No.	Calibration Date Next Calibration
Programmable AC/DC Power Source	NF Corporation	ES18000W	425779	---
EMI Test Receiver	ROHDE & SCHWARZ	ESIB40	100211	April, 2006 April, 2007
Biconical Antenna (30 to 300MHz)	SCHWARZBECK	VHBB9124(Balun) BBA9106(Elements)	311	September, 2006 September, 2007
Log.-Periodic Antenna (300 MHz to 1 GHz)	SCHWARZBECK	UHALP 9108 A	645	September, 2006 September, 2007
Loop Antenna (0.15 to 30 MHz)	ROHDE & SCHWARZ	HFH2-Z2	131	August, 2006 August, 2007
Environment Chamber	ISUZU	HPAF-800-20	---	---