

## 802.11n-HT20 Out-of-Band Emissions - Ant 1 / Ant 0 + 1

### Channel 01 (2412MHz)

#### 100kHz PSD Reference Level

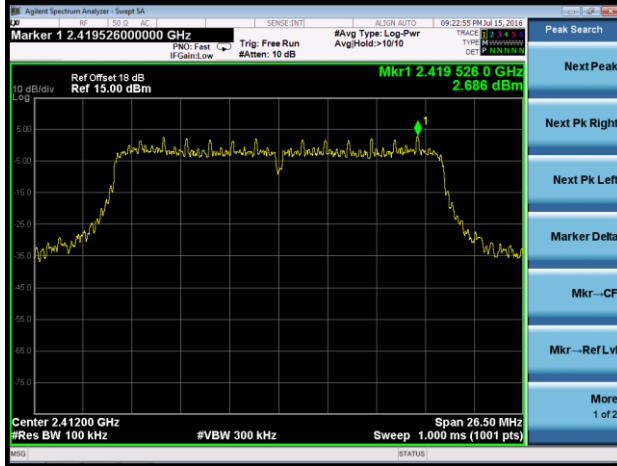

#### Low Band Edge

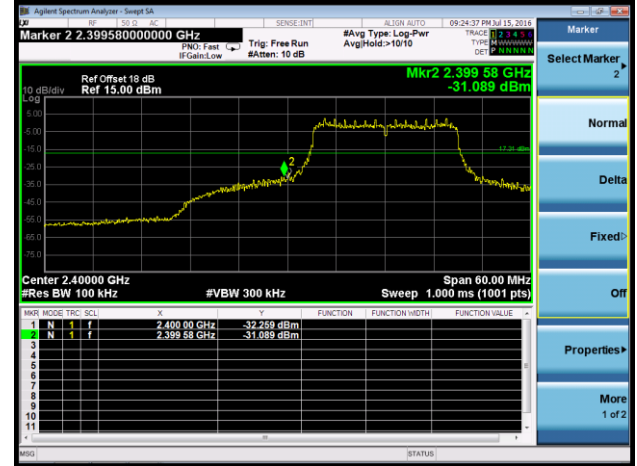

#### Spurious Emission

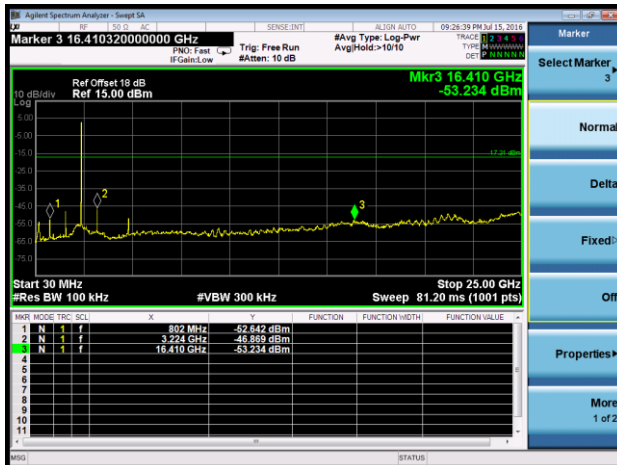

### Channel 06 (2437MHz)

#### 100kHz PSD Reference Level

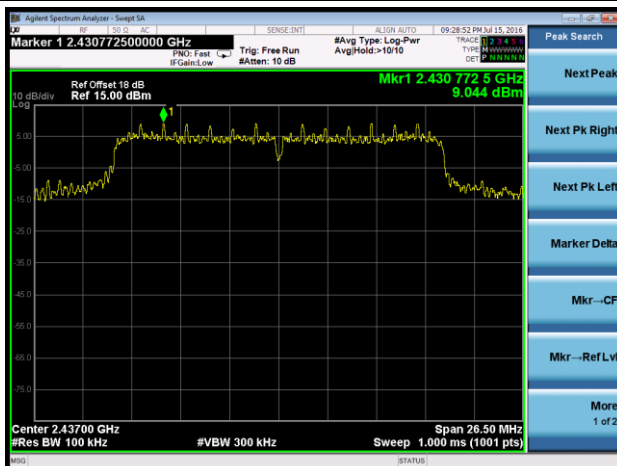

#### Spurious Emission

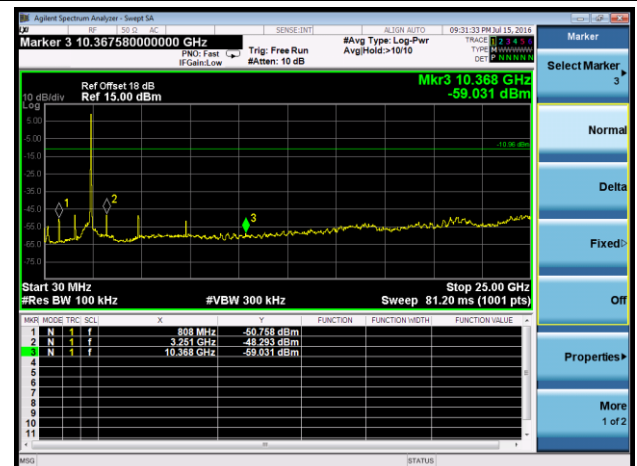

### Channel 11 (2462MHz)

#### 100kHz PSD Reference Level

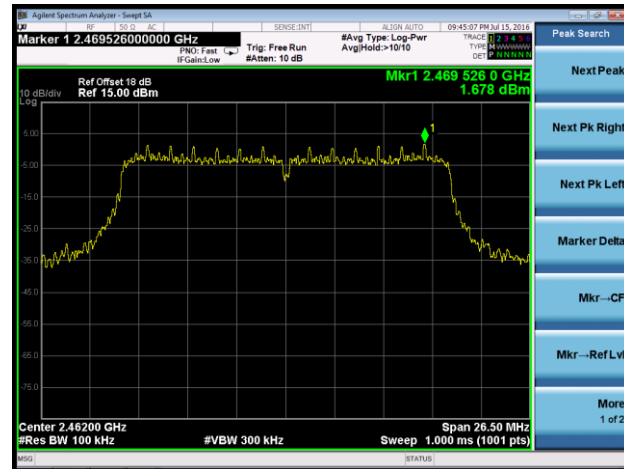

#### High Band Edge



#### Spurious Emission

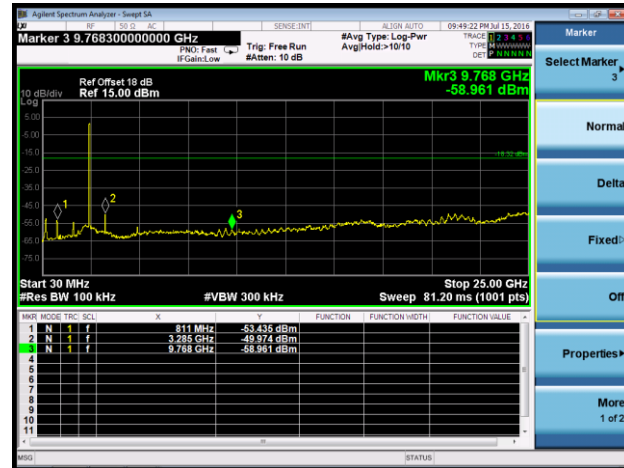

## 802.11n-HT40 Out-of-Band Emissions - Ant 1 / Ant 0 + 1

### Channel 03 (2422MHz)

#### 100kHz PSD Reference Level

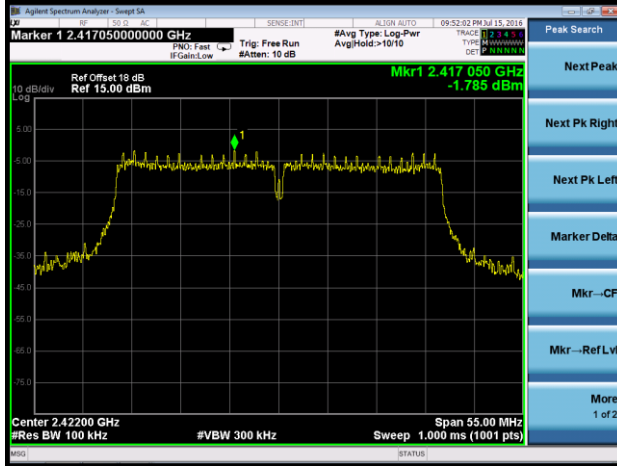

#### Low Band Edge



#### Spurious Emission

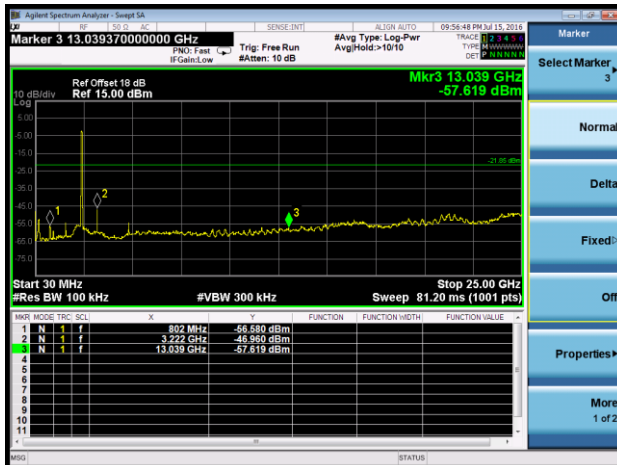

### Channel 06 (2437MHz)

#### 100kHz PSD Reference Level

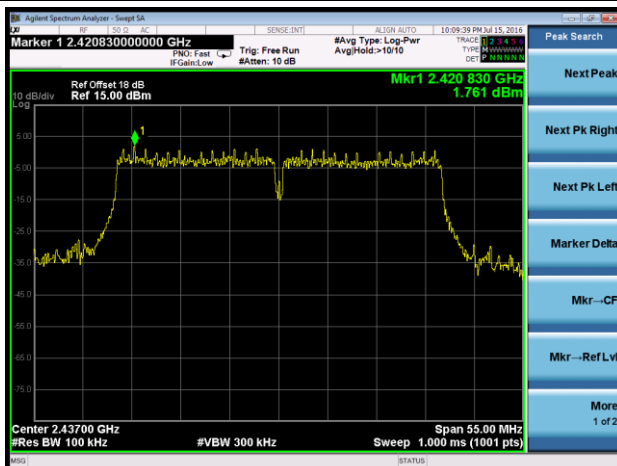

#### Spurious Emission

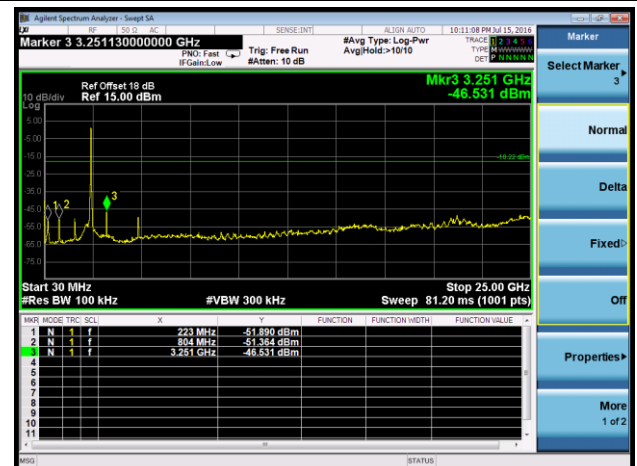

### Channel 09 (2452MHz)

#### 100kHz PSD Reference Level

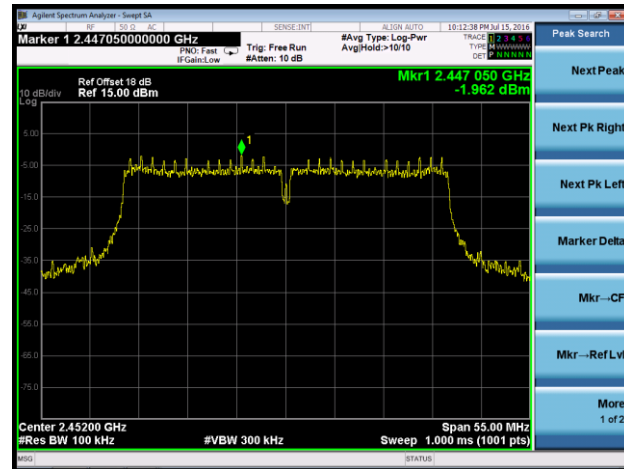

#### High Band Edge



#### Spurious Emission

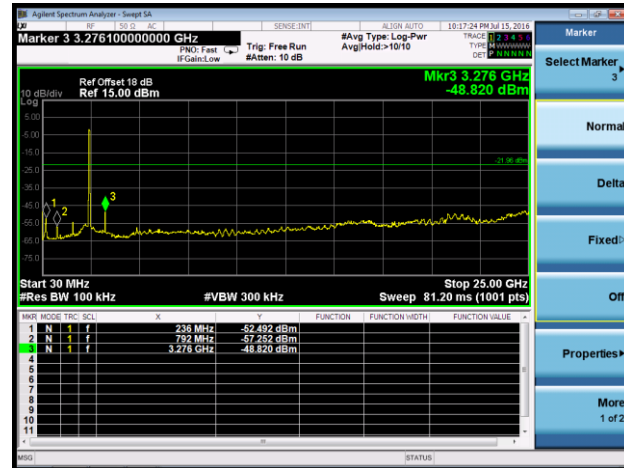

## 7.6. Radiated Spurious Emission Measurement

### 7.6.1. Test Limit

All out of band emissions appearing in a restricted band as specified in Section 15.205 of the Title 47 CFR must not exceed the limits shown in Table per Section 15.209.

FCC Part 15 Subpart C Paragraph 15.209		
Frequency [MHz]	Field Strength [V/m]	Measured Distance [Meters]
0.009 - 0.490	2400/F (kHz)	300
0.490 - 1.705	24000/F (kHz)	30
1.705 - 30	30	30
30 - 88	100	3
88 - 216	150	3
216 - 960	200	3
Above 960	500	3

### 7.6.2. Test Procedure Used

KDB 558074 D01v03r05 - Section 12.2.3 (quasi-peak measurements)

KDB 558074 D01v03r05 - Section 12.2.4 (peak power measurements)

KDB 558074 D01v03r05 - Section 12.2.5 (average power measurements)

### 7.6.3. Test Setting

#### Peak Field Strength Measurements

1. Analyzer center frequency was set to the frequency of the radiated spurious emission of interest
2. RBW = as specified in Table 1
3. VBW = 3MHz
4. Detector = peak
5. Sweep time = auto couple

6.Trace mode = max hold

7.Trace was allowed to stabilize

**Table 1 - RBW as a function of frequency**

Frequency	RBW
9 ~ 150 kHz	200 ~ 300 Hz
0.15 ~ 30 MHz	9 ~ 10 kHz
30 ~ 1000 MHz	100 ~ 120 kHz
> 1000 MHz	1 MHz

### **Average Field Strength Measurements**

1.Analyzer center frequency was set to the frequency of the radiated spurious emission of interest

2.RBW = 1MHz

3.VBW  $\geq$  1/T

4.De As an alternative, the instrument may be set to linear detector mode. Ensure that video filtering is applied in linear voltage domain (rather than in a log or dB domain). Some instruments require linear display mode in order to accomplish this. Others have a setting for Average-VBW Type, which can be set to "Voltage" regardless of the display mode

5.Detector = Peak

6.Sweep time = auto

7.Trace mode = max hold

8.Allow max hold to run for at least 50 times (1/duty cycle) traces

### 7.6.4. Test Setup

#### 9kHz ~ 30MHz Test Setup:

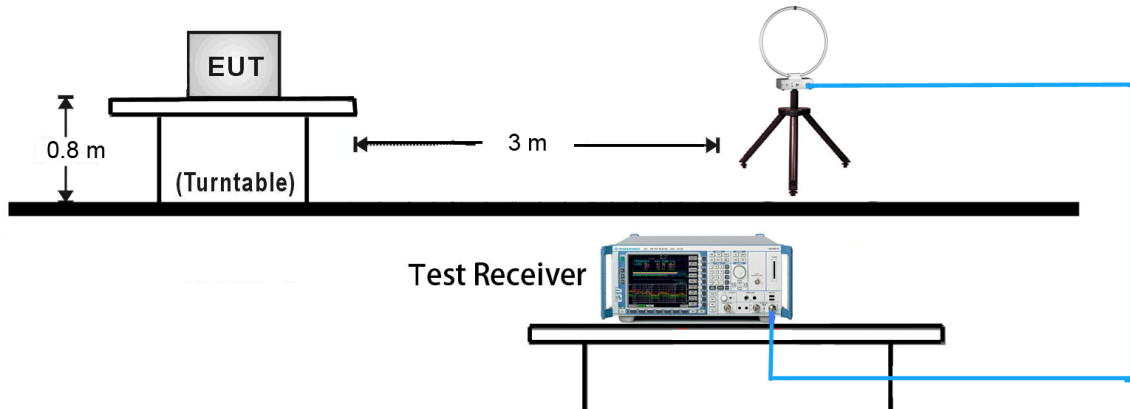

#### 30MHz ~ 1GHz Test Setup:

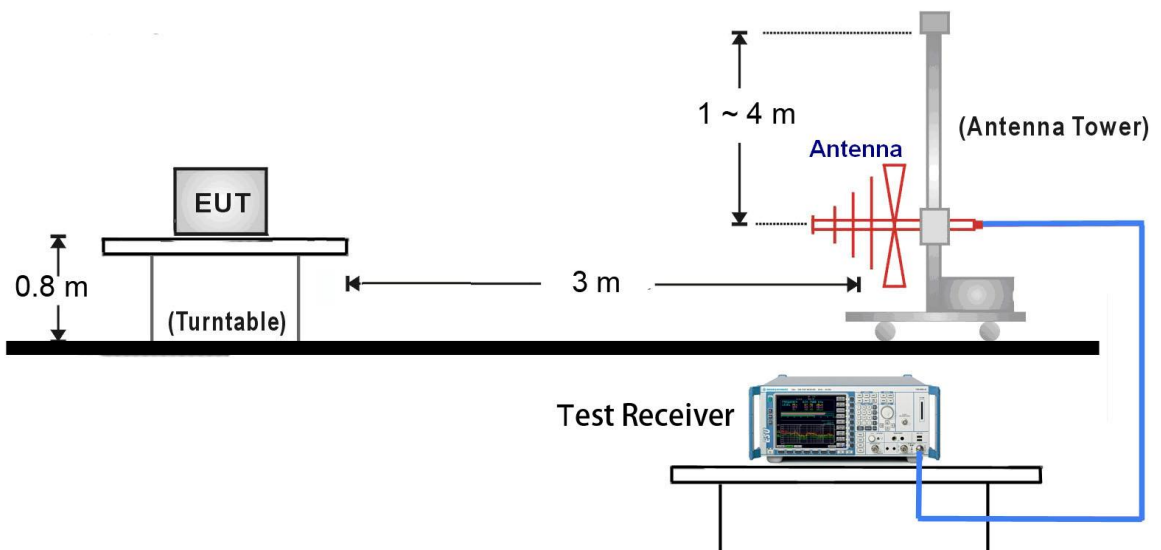

1GHz ~ 18GHz Test Setup:

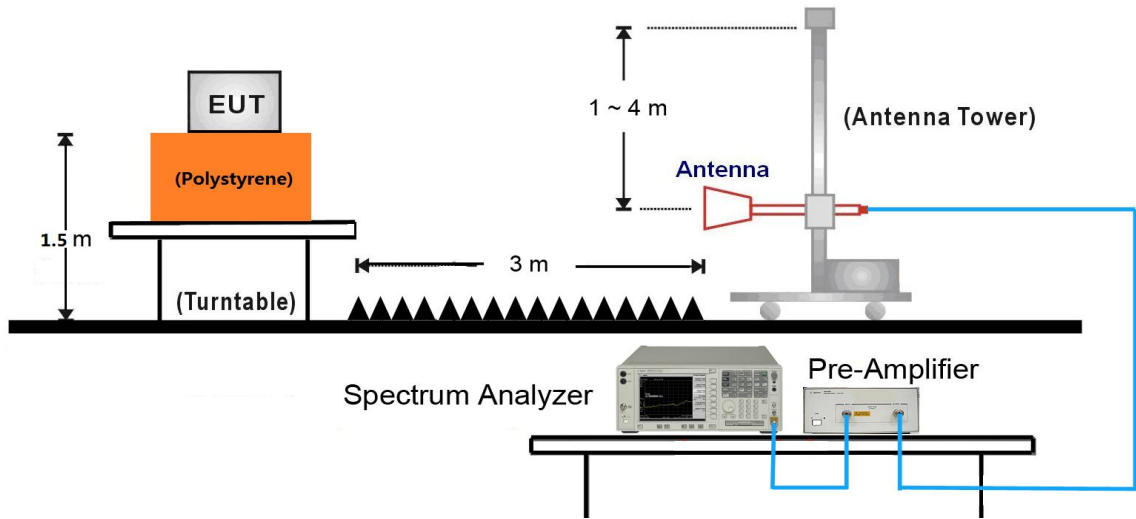

18GHz ~25GHz Test Setup:

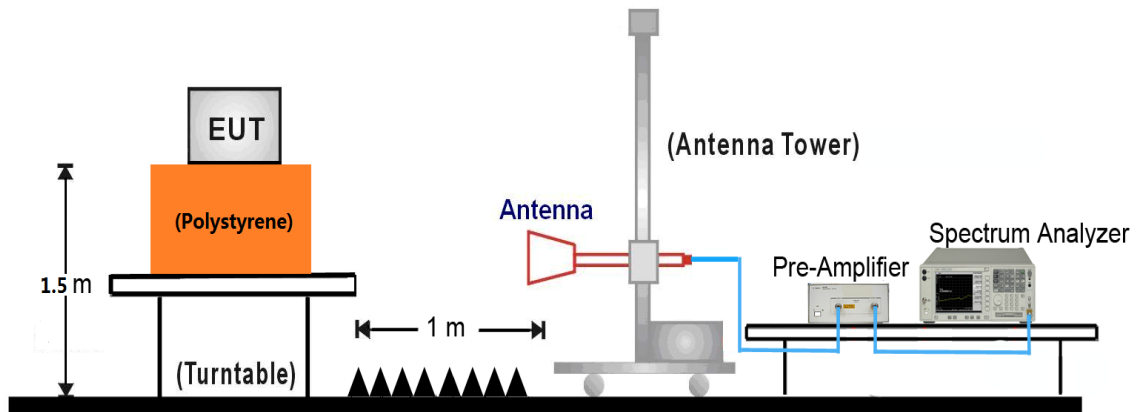



### 7.6.5. Test Result

Test Mode:	802.11b - Ant 0	Test Site:	AC1
Test Channel:	01	Test Engineer:	Roy Cheng
Remark:	1. Average measurement was not performed if peak level lower than average limit. 2. Other frequency was 20dB below limit line within 1-18GHz, there is not show in the report.		

Mark	Frequency (MHz)	Reading Level (dB $\mu$ V)	Factor (dB)	Measure Level (dB $\mu$ V/m)	Limit (dB $\mu$ V/m)	Margin (dB)	Detector	Polarization
	4825.0	45.0	2.7	47.7	74.0	-26.3	Peak	Horizontal
	5368.2	37.2	2.9	40.1	74.0	-33.9	Peak	Horizontal
*	7239.0	47.6	7.8	55.4	91.2	-35.8	Peak	Horizontal
*	9644.5	38.2	11.0	49.2	91.2	-42.0	Peak	Horizontal
	4825.0	48.1	2.7	50.8	74.0	-23.2	Peak	Vertical
	6491.0	34.6	5.9	40.5	74.0	-33.5	Peak	Vertical
*	7239.0	48.0	7.8	55.8	91.2	-35.4	Peak	Vertical
*	9644.5	36.1	11.0	47.1	91.2	-44.1	Peak	Vertical

Note 1: "\*" is not in restricted band, its limit is 20dBc of the fundamental emission level (111.2dB $\mu$ V/m) or FCC 15.209 which is higher.

Note 2: Measure Level (dB $\mu$ V/m) = Reading Level (dB $\mu$ V) + Factor (dB)

Factor (dB) = Cable Loss (dB) + Antenna Factor (dB/m) - Pre\_Amplifier Gain (dB)

Test Mode:	802.11b - Ant 0	Test Site:	AC1
Test Channel:	06	Test Engineer:	Roy Cheng
Remark:	1. Average measurement was not performed if peak level lower than average limit. 2. Other frequency was 20dB below limit line within 1-18GHz, there is not show in the report.		

Mark	Frequency (MHz)	Reading Level (dB $\mu$ V)	Factor (dB)	Measure Level (dB $\mu$ V/m)	Limit (dB $\mu$ V/m)	Margin (dB)	Detector	Polarization
	4876.0	45.1	2.7	47.8	74.0	-26.2	Peak	Horizontal
	7307.0	43.2	8.0	51.2	74.0	-22.8	Peak	Horizontal
*	9610.5	34.6	10.9	45.5	91.3	-45.8	Peak	Horizontal
*	13554.5	34.9	13.9	48.8	91.3	-42.5	Peak	Horizontal
	4876.0	42.1	2.7	44.8	74.0	-29.2	Peak	Vertical
	7310.3	48.9	8.0	56.9	74.0	-17.1	Peak	Vertical
	7310.3	44.5	8.0	52.5	54.0	-1.5	Average	Vertical
*	9746.5	35.8	11.3	47.1	91.3	-44.2	Peak	Vertical
*	13095.5	34.5	12.5	47.0	91.3	-44.3	Peak	Vertical

Note 1: "\*" is not in restricted band, its limit is 20dBc of the fundamental emission level (111.3dB $\mu$ V/m) or FCC 15.209 which is higher.

Note 2: Measure Level (dB $\mu$ V/m) = Reading Level (dB $\mu$ V) + Factor (dB)

Factor (dB) = Cable Loss (dB) + Antenna Factor (dB/m) - Pre\_Amplifier Gain (dB)

Test Mode:	802.11b - Ant 0	Test Site:	AC1
Test Channel:	11	Test Engineer:	Roy Cheng
Remark:	1. Average measurement was not performed if peak level lower than average limit. 2. Other frequency was 20dB below limit line within 1-18GHz, there is not show in the report.		

Mark	Frequency (MHz)	Reading Level (dB $\mu$ V)	Factor (dB)	Measure Level (dB $\mu$ V/m)	Limit (dB $\mu$ V/m)	Margin (dB)	Detector	Polarization
	4927.0	40.7	2.8	43.5	74.0	-30.5	Peak	Horizontal
	7383.5	41.5	7.9	49.4	74.0	-24.6	Peak	Horizontal
*	8888.0	35.5	9.2	44.7	91.4	-46.7	Peak	Horizontal
*	12840.5	35.4	11.9	47.3	91.4	-44.1	Peak	Horizontal
	4927.0	49.6	2.8	52.4	74.0	-21.6	Peak	Vertical
	7385.2	46.5	7.9	54.4	74.0	-19.6	Peak	Vertical
	7385.2	42.0	7.9	49.9	54.0	-4.1	Average	Vertical
*	9755.0	34.1	11.4	45.5	91.4	-45.9	Peak	Vertical
*	12968.0	34.0	12.2	46.2	91.4	-45.2	Peak	Vertical

Note 1: "\*" is not in restricted band, its limit is 20dBc of the fundamental emission level (111.4dB $\mu$ V/m) or FCC 15.209 which is higher.

Note 2: Measure Level (dB $\mu$ V/m) = Reading Level (dB $\mu$ V) + Factor (dB)

Factor (dB) = Cable Loss (dB) + Antenna Factor (dB/m) - Pre\_Amplifier Gain (dB)

Test Mode:	802.11g - Ant 0	Test Site:	AC1
Test Channel:	01	Test Engineer:	Roy Cheng
Remark:	1. Average measurement was not performed if peak level lower than average limit. 2. Other frequency was 20dB below limit line within 1-18GHz, there is not show in the report.		

Mark	Frequency (MHz)	Reading Level (dB $\mu$ V)	Factor (dB)	Measure Level (dB $\mu$ V/m)	Limit (dB $\mu$ V/m)	Margin (dB)	Detector	Polarization
	4816.5	36.6	2.7	39.3	74.0	-34.7	Peak	Horizontal
	5369.0	36.2	3.0	39.2	74.0	-34.8	Peak	Horizontal
*	7230.5	44.2	7.8	52.0	91.5	-39.5	Peak	Horizontal
*	10409.5	35.2	12.3	47.5	91.5	-44.0	Peak	Horizontal
	3839.0	37.2	0.0	37.2	74.0	-36.8	Peak	Vertical
	4833.5	40.4	2.7	43.1	74.0	-30.9	Peak	Vertical
*	7239.0	44.3	7.8	52.1	91.5	-39.4	Peak	Vertical
*	10392.5	34.9	12.3	47.2	91.5	-44.3	Peak	Vertical

Note 1: "\*" is not in restricted band, its limit is 20dBc of the fundamental emission level (111.5dB $\mu$ V/m) or FCC 15.209 which is higher.

Note 2: Measure Level (dB $\mu$ V/m) = Reading Level (dB $\mu$ V) + Factor (dB)

Factor (dB) = Cable Loss (dB) + Antenna Factor (dB/m) - Pre\_Amplifier Gain (dB)

Test Mode:	802.11g - Ant 0	Test Site:	AC1
Test Channel:	06	Test Engineer:	Roy Cheng
Remark:	1. Average measurement was not performed if peak level lower than average limit. 2. Other frequency was 20dB below limit line within 1-18GHz, there is not show in the report.		

Mark	Frequency (MHz)	Reading Level (dB $\mu$ V)	Factor (dB)	Measure Level (dB $\mu$ V/m)	Limit (dB $\mu$ V/m)	Margin (dB)	Detector	Polarization
	4876.0	41.8	2.7	44.5	74.0	-29.5	Peak	Horizontal
	7310.4	46.6	8.0	54.6	74.0	-19.4	Peak	Horizontal
	7310.4	33.4	8.0	41.4	54.0	-12.6	Average	Horizontal
*	8624.5	35.4	8.8	44.2	104.7	-60.5	Peak	Horizontal
*	10528.5	34.6	12.5	47.1	104.7	-57.6	Peak	Horizontal
	4876.0	43.2	2.7	45.9	74.0	-28.1	Peak	Vertical
	7310.7	52.7	8.0	60.7	74.0	-13.3	Peak	Vertical
	7310.7	37.9	8.0	45.9	54.0	-8.1	Average	Vertical
*	9746.5	35.0	11.3	46.3	104.7	-58.4	Peak	Vertical
*	13444.0	34.6	13.7	48.3	104.7	-56.4	Peak	Vertical

Note 1: "\*" is not in restricted band, its limit is 20dBc of the fundamental emission level (124.7dB $\mu$ V/m) or FCC 15.209 which is higher.

Note 2: Measure Level (dB $\mu$ V/m) = Reading Level (dB $\mu$ V) + Factor (dB)

Factor (dB) = Cable Loss (dB) + Antenna Factor (dB/m) - Pre\_Amplifier Gain (dB)

Test Mode:	802.11g - Ant 0	Test Site:	AC1
Test Channel:	11	Test Engineer:	Roy Cheng
Remark:	1. Average measurement was not performed if peak level lower than average limit. 2. Other frequency was 20dB below limit line within 1-18GHz, there is not show in the report.		

Mark	Frequency (MHz)	Reading Level (dB $\mu$ V)	Factor (dB)	Measure Level (dB $\mu$ V/m)	Limit (dB $\mu$ V/m)	Margin (dB)	Detector	Polarization
	4927.0	38.4	2.8	41.2	74.0	-32.8	Peak	Horizontal
	7383.5	36.1	7.9	44.0	74.0	-30.0	Peak	Horizontal
*	9610.5	34.6	10.9	45.5	89.0	-43.5	Peak	Horizontal
*	13435.5	34.0	13.6	47.6	89.0	-41.4	Peak	Horizontal
	4927.0	40.2	2.8	43.0	74.0	-31.0	Peak	Vertical
	7383.5	40.1	7.9	48.0	74.0	-26.0	Peak	Vertical
*	9627.5	34.7	11.0	45.7	89.0	-43.3	Peak	Vertical
*	13180.5	34.5	12.6	47.1	89.0	-41.9	Peak	Vertical

Note 1: "\*" is not in restricted band, its limit is 20dBc of the fundamental emission level (109.0dB $\mu$ V/m) or FCC 15.209 which is higher.

Note 2: Measure Level (dB $\mu$ V/m) = Reading Level (dB $\mu$ V) + Factor (dB)

Factor (dB) = Cable Loss (dB) + Antenna Factor (dB/m) - Pre\_Amplifier Gain (dB)

Test Mode:	802.11b - Ant 1	Test Site:	AC1
Test Channel:	01	Test Engineer:	Roy Cheng
Remark:	1. Average measurement was not performed if peak level lower than average limit. 2. Other frequency was 20dB below limit line within 1-18GHz, there is not show in the report.		

Mark	Frequency (MHz)	Reading Level (dBμV)	Factor (dB)	Measure Level (dBμV/m)	Limit (dBμV/m)	Margin (dB)	Detector	Polarization
	3992.0	37.3	0.4	37.7	74.0	-36.3	Peak	Horizontal
	4825.0	39.5	2.7	42.2	74.0	-31.8	Peak	Horizontal
*	7239.0	35.6	7.8	43.4	91.3	-47.9	Peak	Horizontal
*	10384.0	33.6	12.3	45.9	91.3	-45.4	Peak	Horizontal
	4145.0	36.7	0.7	37.4	74.0	-36.6	Peak	Vertical
	4824.0	51.5	2.7	54.2	74.0	-19.8	Peak	Vertical
	4824.0	50.0	2.7	52.7	54.0	-1.3	Average	Vertical
*	7230.5	35.8	7.8	43.6	91.3	-47.7	Peak	Vertical
*	9755.0	33.8	11.4	45.2	91.3	-46.1	Peak	Vertical

Note 1: "\*" is not in restricted band, its limit is 20dBc of the fundamental emission level (111.3dBμV/m) or FCC 15.209 which is higher.

Note 2: Measure Level (dBμV/m) = Reading Level (dBμV) + Factor (dB)

Factor (dB) = Cable Loss (dB) + Antenna Factor (dB/m) - Pre\_Amplifier Gain (dB)

Test Mode:	802.11b - Ant 1	Test Site:	AC1
Test Channel:	06	Test Engineer:	Roy Cheng
Remark:	1. Average measurement was not performed if peak level lower than average limit. 2. Other frequency was 20dB below limit line within 1-18GHz, there is not show in the report.		

Mark	Frequency (MHz)	Reading Level (dBμV)	Factor (dB)	Measure Level (dBμV/m)	Limit (dBμV/m)	Margin (dB)	Detector	Polarization
	4876.0	44.8	2.7	47.5	74.0	-26.5	Peak	Horizontal
	7315.5	35.6	8.0	43.6	74.0	-30.4	Peak	Horizontal
*	9746.5	34.1	11.3	45.4	91.8	-46.4	Peak	Horizontal
*	13019.0	34.6	12.2	46.8	91.8	-45.0	Peak	Horizontal
	4876.0	51.8	2.7	54.5	74.0	-19.5	Peak	Vertical
	4874.0	50.2	2.7	52.9	54.0	-1.1	Average	Vertical
	7307.0	37.8	8.0	45.8	74.0	-28.2	Peak	Vertical
*	10137.5	34.3	11.6	45.9	91.8	-45.9	Peak	Vertical
*	13801.0	34.0	14.4	48.4	91.8	-43.4	Peak	Vertical

Note 1: "\*" is not in restricted band, its limit is 20dBc of the fundamental emission level (111.8dBμV/m) or FCC 15.209 which is higher.

Note 2: Measure Level (dBμV/m) = Reading Level (dBμV) + Factor (dB)

Factor (dB) = Cable Loss (dB) + Antenna Factor (dB/m) - Pre\_Amplifier Gain (dB)



Test Mode:	802.11b - Ant 1	Test Site:	AC1
Test Channel:	11	Test Engineer:	Roy Cheng
Remark:	1. Average measurement was not performed if peak level lower than average limit. 2. Other frequency was 20dB below limit line within 1-18GHz, there is not show in the report.		

Mark	Frequency (MHz)	Reading Level (dB $\mu$ V)	Factor (dB)	Measure Level (dB $\mu$ V/m)	Limit (dB $\mu$ V/m)	Margin (dB)	Detector	Polarization
	4927.0	43.5	2.8	46.3	74.0	-27.7	Peak	Horizontal
	7290.0	34.7	8.0	42.7	74.0	-31.3	Peak	Horizontal
*	9602.0	33.6	10.9	44.5	90.3	-45.8	Peak	Horizontal
*	12840.5	34.9	11.9	46.8	90.3	-43.5	Peak	Horizontal
	4924.0	51.5	2.8	54.3	74.0	-19.7	Peak	Vertical
	4924.0	50.0	2.8	52.8	54.0	-1.2	Average	Vertical
	7383.5	37.1	7.9	45.0	74.0	-29.0	Peak	Vertical
*	9848.5	34.2	11.6	45.8	90.3	-44.5	Peak	Vertical
*	13537.5	35.2	13.8	49.0	90.3	-41.3	Peak	Vertical

Note 1: "\*" is not in restricted band, its limit is 20dBc of the fundamental emission level (110.3dB $\mu$ V/m) or FCC 15.209 which is higher.

Note 2: Measure Level (dB $\mu$ V/m) = Reading Level (dB $\mu$ V) + Factor (dB)

Factor (dB) = Cable Loss (dB) + Antenna Factor (dB/m) - Pre\_Amplifier Gain (dB)

Test Mode:	802.11g - Ant 1	Test Site:	AC1
Test Channel:	01	Test Engineer:	Roy Cheng
Remark:	1. Average measurement was not performed if peak level lower than average limit. 2. Other frequency was 20dB below limit line within 1-18GHz, there is not show in the report.		

Mark	Frequency (MHz)	Reading Level (dBμV)	Factor (dB)	Measure Level (dBμV/m)	Limit (dBμV/m)	Margin (dB)	Detector	Polarization
	4825.0	35.6	2.7	38.3	74.0	-35.7	Peak	Horizontal
	7392.0	35.5	7.9	43.4	74.0	-30.6	Peak	Horizontal
*	10690.0	34.7	12.4	47.1	89.8	-42.7	Peak	Horizontal
*	13614.0	34.5	13.9	48.4	89.8	-41.4	Peak	Horizontal
	3915.5	36.9	0.2	37.1	74.0	-36.9	Peak	Vertical
	4816.5	46.9	2.7	49.6	74.0	-24.4	Peak	Vertical
*	7239.0	36.3	7.8	44.1	89.8	-45.7	Peak	Vertical
*	10052.5	34.1	11.5	45.6	89.8	-44.2	Peak	Vertical

Note 1: "\*" is not in restricted band, its limit is 20dBc of the fundamental emission level (109.8dBμV/m) or FCC 15.209 which is higher.

Note 2: Measure Level (dBμV/m) = Reading Level (dBμV) + Factor (dB)

Factor (dB) = Cable Loss (dB) + Antenna Factor (dB/m) - Pre\_Amplifier Gain (dB)

Test Mode:	802.11g - Ant 1	Test Site:	AC1
Test Channel:	06	Test Engineer:	Roy Cheng
Remark:	1. Average measurement was not performed if peak level lower than average limit. 2. Other frequency was 20dB below limit line within 1-18GHz, there is not show in the report.		

Mark	Frequency (MHz)	Reading Level (dB $\mu$ V)	Factor (dB)	Measure Level (dB $\mu$ V/m)	Limit (dB $\mu$ V/m)	Margin (dB)	Detector	Polarization
	4876.0	42.3	2.7	45.0	74.0	-29.0	Peak	Horizontal
	7307.0	39.8	8.0	47.8	74.0	-26.2	Peak	Horizontal
*	9746.5	35.7	11.3	47.0	103.2	-56.2	Peak	Horizontal
*	13724.5	35.1	14.1	49.2	103.2	-54.0	Peak	Horizontal
	4867.5	49.4	2.7	52.1	74.0	-21.9	Peak	Vertical
	7298.5	44.1	8.0	52.1	74.0	-21.9	Peak	Vertical
*	9755.0	36.1	11.4	47.5	103.2	-55.7	Peak	Vertical
*	14727.5	34.0	15.6	49.6	103.2	-53.6	Peak	Vertical

Note 1: "\*" is not in restricted band, its limit is 20dBc of the fundamental emission level (123.2dB $\mu$ V/m) or FCC 15.209 which is higher.

Note 2: Measure Level (dB $\mu$ V/m) = Reading Level (dB $\mu$ V) + Factor (dB)

Factor (dB) = Cable Loss (dB) + Antenna Factor (dB/m) - Pre\_Amplifier Gain (dB)

Test Mode:	802.11g - Ant 1	Test Site:	AC1
Test Channel:	11	Test Engineer:	Roy Cheng
Remark:	1. Average measurement was not performed if peak level lower than average limit. 2. Other frequency was 20dB below limit line within 1-18GHz, there is not show in the report.		

Mark	Frequency (MHz)	Reading Level (dB $\mu$ V)	Factor (dB)	Measure Level (dB $\mu$ V/m)	Limit (dB $\mu$ V/m)	Margin (dB)	Detector	Polarization
	4927.0	36.1	2.8	38.9	74.0	-35.1	Peak	Horizontal
	7417.5	35.0	8.0	43.0	74.0	-31.0	Peak	Horizontal
*	10554.0	34.0	12.5	46.5	87.9	-41.4	Peak	Horizontal
*	13784.0	35.2	14.3	49.5	87.9	-38.4	Peak	Horizontal
	4927.0	42.9	2.8	45.7	74.0	-28.3	Peak	Vertical
	7392.0	35.9	7.9	43.8	74.0	-30.2	Peak	Vertical
*	9695.5	34.9	10.9	45.8	87.9	-42.1	Peak	Vertical
*	13784.0	32.9	14.3	47.2	87.9	-40.7	Peak	Vertical

Note 1: "\*" is not in restricted band, its limit is 20dBc of the fundamental emission level (107.9dB $\mu$ V/m) or FCC 15.209 which is higher.

Note 2: Measure Level (dB $\mu$ V/m) = Reading Level (dB $\mu$ V) + Factor (dB)

Factor (dB) = Cable Loss (dB) + Antenna Factor (dB/m) - Pre\_Amplifier Gain (dB)

Test Mode:	802.11n-HT20 - Ant 0 + 1	Test Site:	AC1
Test Channel:	01	Test Engineer:	Roy Cheng
Remark:	1. Average measurement was not performed if peak level lower than average limit. 2. Other frequency was 20dB below limit line within 1-18GHz, there is not show in the report.		

Mark	Frequency (MHz)	Reading Level (dB $\mu$ V)	Factor (dB)	Measure Level (dB $\mu$ V/m)	Limit (dB $\mu$ V/m)	Margin (dB)	Detector	Polarization
	4119.5	36.5	0.7	37.2	74.0	-36.8	Peak	Horizontal
	4825.0	37.4	2.7	40.1	74.0	-33.9	Peak	Horizontal
*	7239.0	37.9	7.8	45.7	91.8	-46.1	Peak	Horizontal
*	9636.0	34.4	11.0	45.4	91.8	-46.4	Peak	Horizontal
	3915.5	36.5	0.2	36.7	74.0	-37.3	Peak	Vertical
	4825.0	47.5	2.7	50.2	74.0	-23.8	Peak	Vertical
*	7230.5	40.8	7.8	48.6	91.8	-43.2	Peak	Vertical
*	10197.0	34.3	11.8	46.1	91.8	-45.7	Peak	Vertical

Note 1: "\*" is not in restricted band, its limit is 20dBc of the fundamental emission level (111.8dB $\mu$ V/m) or FCC 15.209 which is higher.

Note 2: Measure Level (dB $\mu$ V/m) = Reading Level (dB $\mu$ V) + Factor (dB)

Factor (dB) = Cable Loss (dB) + Antenna Factor (dB/m) - Pre\_Amplifier Gain (dB)

Test Mode:	802.11n-HT20 - Ant 0 + 1	Test Site:	AC1
Test Channel:	06	Test Engineer:	Roy Cheng
Remark:	1. Average measurement was not performed if peak level lower than average limit. 2. Other frequency was 20dB below limit line within 1-18GHz, there is not show in the report.		

Mark	Frequency (MHz)	Reading Level (dB $\mu$ V)	Factor (dB)	Measure Level (dB $\mu$ V/m)	Limit (dB $\mu$ V/m)	Margin (dB)	Detector	Polarization
	4867.5	43.5	2.7	46.2	74.0	-27.8	Peak	Horizontal
	7315.5	45.0	8.0	53.0	74.0	-21.0	Peak	Horizontal
*	9738.0	35.1	11.2	46.3	108.5	-62.2	Peak	Horizontal
*	12840.5	33.9	11.9	45.8	108.5	-62.7	Peak	Horizontal
	4876.0	48.4	2.7	51.1	74.0	-22.9	Peak	Vertical
	7311.6	50.5	8.0	58.5	74.0	-15.5	Peak	Vertical
	7311.6	33.9	8.0	41.9	54.0	-12.1	Average	Vertical
*	9755.0	35.0	11.4	46.4	108.5	-62.1	Peak	Vertical
*	13478.0	34.0	13.7	47.7	108.5	-60.8	Peak	Vertical

Note 1: "\*" is not in restricted band, its limit is 20dBc of the fundamental emission level (128.5dB $\mu$ V/m) or FCC 15.209 which is higher.

Note 2: Measure Level (dB $\mu$ V/m) = Reading Level (dB $\mu$ V) + Factor (dB)

Factor (dB) = Cable Loss (dB) + Antenna Factor (dB/m) - Pre\_Amplifier Gain (dB)

Test Mode:	802.11n-HT20 - Ant 0 + 1	Test Site:	AC1
Test Channel:	11	Test Engineer:	Roy Cheng
Remark:	1. Average measurement was not performed if peak level lower than average limit. 2. Other frequency was 20dB below limit line within 1-18GHz, there is not show in the report.		

Mark	Frequency (MHz)	Reading Level (dBμV)	Factor (dB)	Measure Level (dBμV/m)	Limit (dBμV/m)	Margin (dB)	Detector	Polarization
	4927.0	38.0	2.8	40.8	74.0	-33.2	Peak	Horizontal
	7273.0	35.4	8.0	43.4	74.0	-30.6	Peak	Horizontal
*	9755.0	33.9	11.4	45.3	91.0	-45.7	Peak	Horizontal
*	13588.5	34.5	13.9	48.4	91.0	-42.6	Peak	Horizontal
	4918.5	43.1	2.8	45.9	74.0	-28.1	Peak	Vertical
	7375.0	37.1	7.9	45.0	74.0	-29.0	Peak	Vertical
*	9916.5	34.3	11.5	45.8	91.0	-45.2	Peak	Vertical
*	13401.5	35.2	13.7	48.9	91.0	-42.1	Peak	Vertical

Note 1: "\*" is not in restricted band, its limit is 20dBc of the fundamental emission level (111.0dBμV/m) or FCC 15.209 which is higher.

Note 2: Measure Level (dBμV/m) = Reading Level (dBμV) + Factor (dB)

Factor (dB) = Cable Loss (dB) + Antenna Factor (dB/m) - Pre\_Amplifier Gain (dB)

Test Mode:	802.11n-HT40 - Ant 0 + 1	Test Site:	AC1
Test Channel:	03	Test Engineer:	Roy Cheng
Remark:	1. Average measurement was not performed if peak level lower than average limit. 2. Other frequency was 20dB below limit line within 1-18GHz, there is not show in the report.		

Mark	Frequency (MHz)	Reading Level (dB $\mu$ V)	Factor (dB)	Measure Level (dB $\mu$ V/m)	Limit (dB $\mu$ V/m)	Margin (dB)	Detector	Polarization
	3881.5	36.9	0.1	37.0	74.0	-37.0	Peak	Horizontal
	4850.5	34.8	2.7	37.5	74.0	-36.5	Peak	Horizontal
*	6372.0	34.7	5.3	40.0	89.4	-49.4	Peak	Horizontal
*	9636.0	34.6	11.0	45.6	89.4	-43.8	Peak	Horizontal
	4842.0	42.8	2.7	45.5	74.0	-28.5	Peak	Vertical
	7273.0	35.5	8.0	43.5	74.0	-30.5	Peak	Vertical
*	9653.0	34.1	11.0	45.1	89.4	-44.3	Peak	Vertical
*	12917.0	34.4	12.1	46.5	89.4	-42.9	Peak	Vertical

Note 1: "\*" is not in restricted band, its limit is 20dBc of the fundamental emission level (109.4dB $\mu$ V/m) or FCC 15.209 which is higher.

Note 2: Measure Level (dB $\mu$ V/m) = Reading Level (dB $\mu$ V) + Factor (dB)

Factor (dB) = Cable Loss (dB) + Antenna Factor (dB/m) - Pre\_Amplifier Gain (dB)



Test Mode:	802.11n-HT40 - Ant 0 + 1	Test Site:	AC1
Test Channel:	06	Test Engineer:	Roy Cheng
Remark:	1. Average measurement was not performed if peak level lower than average limit. 2. Other frequency was 20dB below limit line within 1-18GHz, there is not show in the report.		

Mark	Frequency (MHz)	Reading Level (dB $\mu$ V)	Factor (dB)	Measure Level (dB $\mu$ V/m)	Limit (dB $\mu$ V/m)	Margin (dB)	Detector	Polarization
	4867.5	43.4	2.7	46.1	74.0	-27.9	Peak	Horizontal
	7281.5	44.8	8.0	52.8	74.0	-21.2	Peak	Horizontal
*	9712.5	35.0	11.0	46.0	102.7	-56.7	Peak	Horizontal
*	13180.5	34.8	12.6	47.4	102.7	-55.3	Peak	Horizontal
	4867.5	46.5	2.7	49.2	74.0	-24.8	Peak	Vertical
	7308.8	46.8	8.0	54.8	74.0	-19.2	Peak	Vertical
	7308.8	30.9	8.0	38.9	54.0	-15.1	Average	Vertical
*	9661.5	34.5	11.0	45.5	102.7	-57.2	Peak	Vertical
*	13138.0	34.6	12.5	47.1	102.7	-55.6	Peak	Vertical

Note 1: "\*" is not in restricted band, its limit is 20dBc of the fundamental emission level (122.7dB $\mu$ V/m) or FCC 15.209 which is higher.

Note 2: Measure Level (dB $\mu$ V/m) = Reading Level (dB $\mu$ V) + Factor (dB)

Factor (dB) = Cable Loss (dB) + Antenna Factor (dB/m) - Pre\_Amplifier Gain (dB)

Test Mode:	802.11n-HT40 - Ant 0 + 1	Test Site:	AC1
Test Channel:	09	Test Engineer:	Roy Cheng
Remark:	1. Average measurement was not performed if peak level lower than average limit. 2. Other frequency was 20dB below limit line within 1-18GHz, there is not show in the report.		

Mark	Frequency (MHz)	Reading Level (dB $\mu$ V)	Factor (dB)	Measure Level (dB $\mu$ V/m)	Limit (dB $\mu$ V/m)	Margin (dB)	Detector	Polarization
	3890.0	36.8	0.2	37.0	74.0	-37.0	Peak	Horizontal
	4901.5	36.2	2.7	38.9	74.0	-35.1	Peak	Horizontal
*	6457.0	33.6	5.8	39.4	88.3	-48.9	Peak	Horizontal
*	9891.0	33.3	11.6	44.9	88.3	-43.4	Peak	Horizontal
	4136.5	36.8	0.7	37.5	74.0	-36.5	Peak	Vertical
	4901.5	40.2	2.7	42.9	74.0	-31.1	Peak	Vertical
*	7791.5	35.3	8.3	43.6	88.3	-44.7	Peak	Vertical
*	10188.5	33.7	11.8	45.5	88.3	-42.8	Peak	Vertical

Note 1: "\*" is not in restricted band, its limit is 20dBc of the fundamental emission level (108.3dB $\mu$ V/m) or FCC 15.209 which is higher.

Note 2: Measure Level (dB $\mu$ V/m) = Reading Level (dB $\mu$ V) + Factor (dB)

Factor (dB) = Cable Loss (dB) + Antenna Factor (dB/m) - Pre\_Amplifier Gain (dB)

**The worst case of Radiated Emission below 1GHz:**

Site: AC1	Time: 2016/07/15 - 14:28
Limit: FCC_Part15.209_RE(3m)	Engineer: Milo Li
Probe: VULB9162_0.03-8GHz	Polarity: Horizontal
EUT: Wireless VOIP Router	Power: AC 120V/60Hz
<b>Note: There is the worst case within frequency range 30MHz~1GHz.</b>	

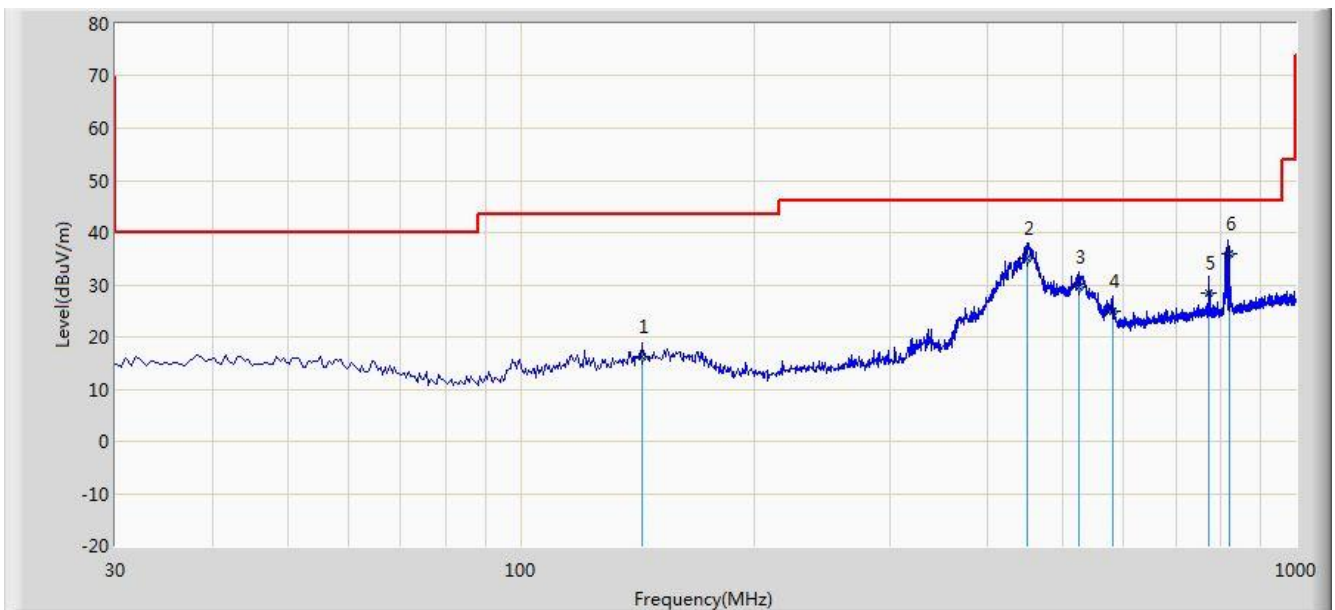

No	Flag	Mark	Frequency (MHz)	Measure Level (dBuV/m)	Reading Level (dBuV)	Over Limit (dB)	Limit (dBuV/m)	Factor (dB)	Type
1			143.500	16.195	1.466	-27.305	43.500	14.729	QP
2			450.146	35.077	17.254	-10.923	46.000	17.824	QP
3			525.145	29.639	10.651	-16.361	46.000	18.988	QP
4			579.654	24.881	4.847	-21.119	46.000	20.033	QP
5			773.451	28.530	5.515	-17.470	46.000	23.015	QP
6		*	819.451	35.962	12.564	-10.038	46.000	23.398	QP

Note: Measure Level (dBuV/m) = Reading Level (dBuV) + Factor (dB)

Factor (dB) = Cable Loss (dB) + Antenna Factor (dB/m)

Site: AC1	Time: 2016/07/15 - 14:36
Limit: FCC_Part15.209_RE(3m)	Engineer: Milo Li
Probe: VULB9162_0.03-8GHz	Polarity: Vertical
EUT: Wireless VOIP Router	Power: AC 120V/60Hz
<b>Note: There is the worst case within frequency range 30MHz~1GHz.</b>	

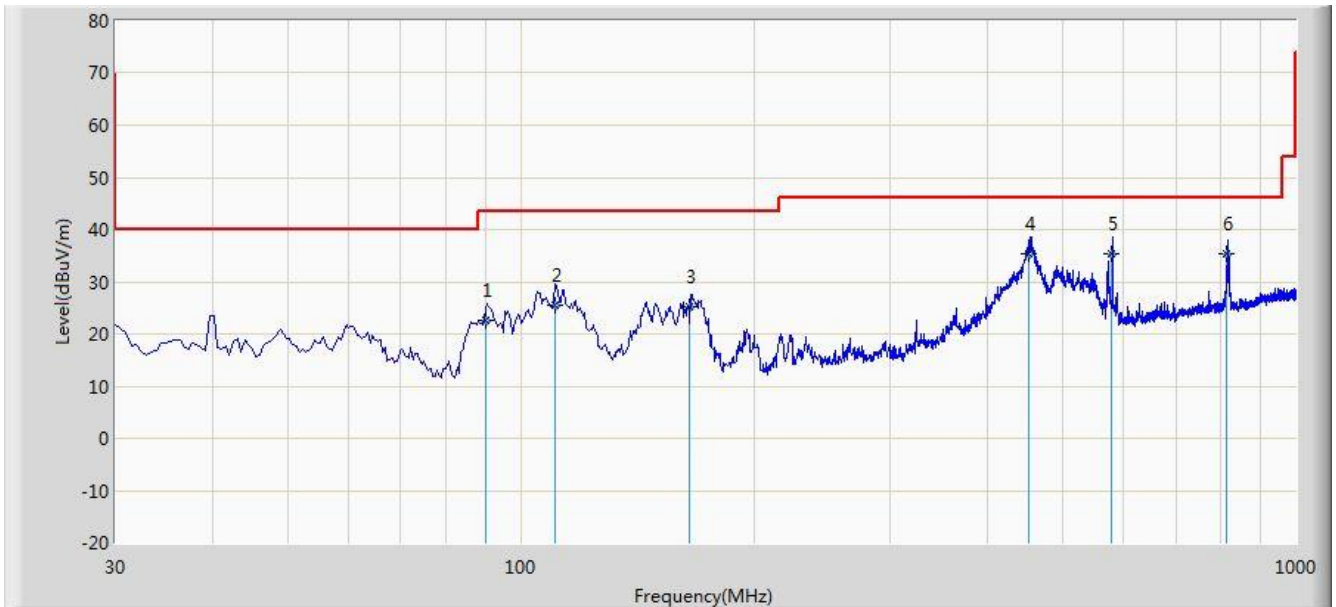

No	Flag	Mark	Frequency (MHz)	Measure Level (dBuV/m)	Reading Level (dBuV)	Over Limit (dB)	Limit (dBuV/m)	Factor (dB)	Type
1			90.156	22.691	12.456	-20.809	43.500	10.235	QP
2			110.564	25.529	13.464	-17.971	43.500	12.065	QP
3			165.165	25.178	10.456	-18.322	43.500	14.722	QP
4		*	453.145	35.425	17.564	-10.575	46.000	17.862	QP
5			579.356	35.260	15.236	-10.740	46.000	20.024	QP
6			815.490	35.264	11.898	-10.736	46.000	23.366	QP

Note: Measure Level (dBuV/m) = Reading Level (dBuV) + Factor (dB)

Factor (dB) = Cable Loss (dB) + Antenna Factor (dB/m)

Site: AC1	Time: 2016/07/15 - 09:44
Limit: FCC_Part15.209_RE(3m)	Engineer: Roy Cheng
Probe: FMZB1519_0.009-30MHz	Polarity: Face on
EUT: Wireless VOIP Router	Power: AC 12V/60Hz
<b>Note: There is the ambient noise within frequency range 9kHz~30MHz.</b>	

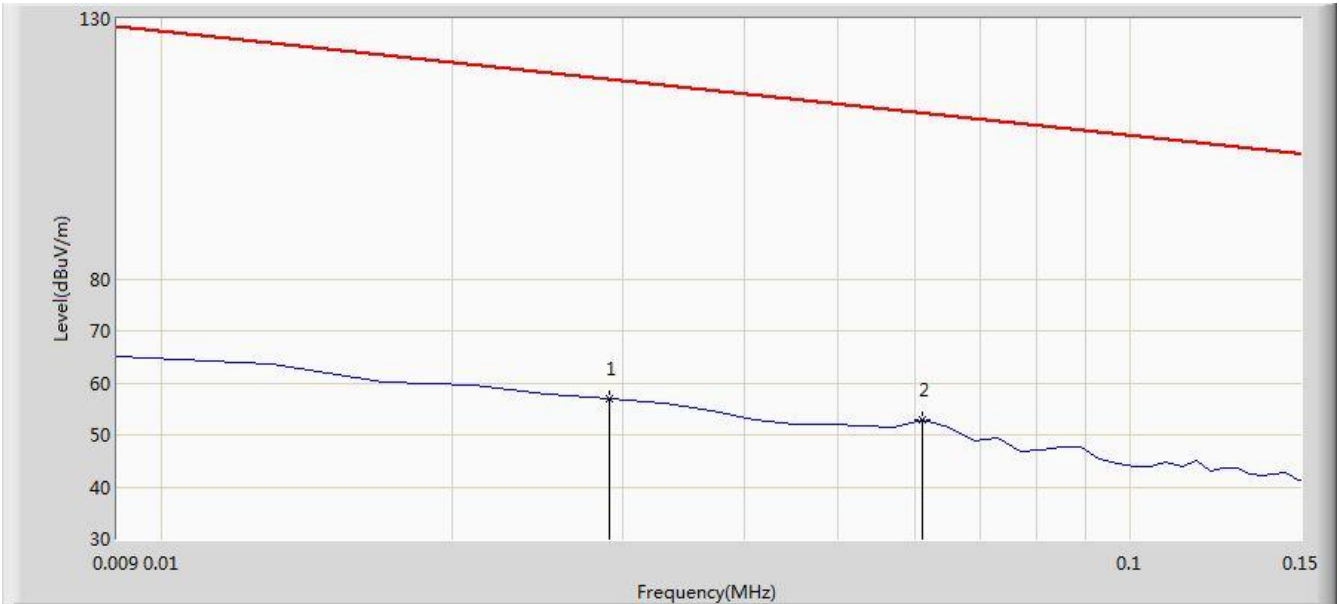

No	Flag	Mark	Frequency (MHz)	Measure Level (dBuV/m)	Reading Level (dBuV)	Over Limit (dB)	Limit (dBuV/m)	Factor (dB)	Type
1			0.029	56.893	35.844	-61.463	118.356	21.049	QP
2		*	0.061	52.853	32.542	-59.045	111.898	20.311	QP

Note: Measure Level (dBμV/m) = Reading Level (dBμV) + Factor (dB)

Factor (dB) = Cable Loss (dB) + Antenna Factor (dB/m)

Site: AC1	Time: 2016/07/15 - 09:44
Limit: FCC_Part15.209_RE(3m)	Engineer: Roy Cheng
Probe: FMZB1519_0.009-30MHz	Polarity: Face on
EUT: Wireless VOIP Router	Power: AC 12V/60Hz
<b>Note: There is the ambient noise within frequency range 9kHz~30MHz.</b>	

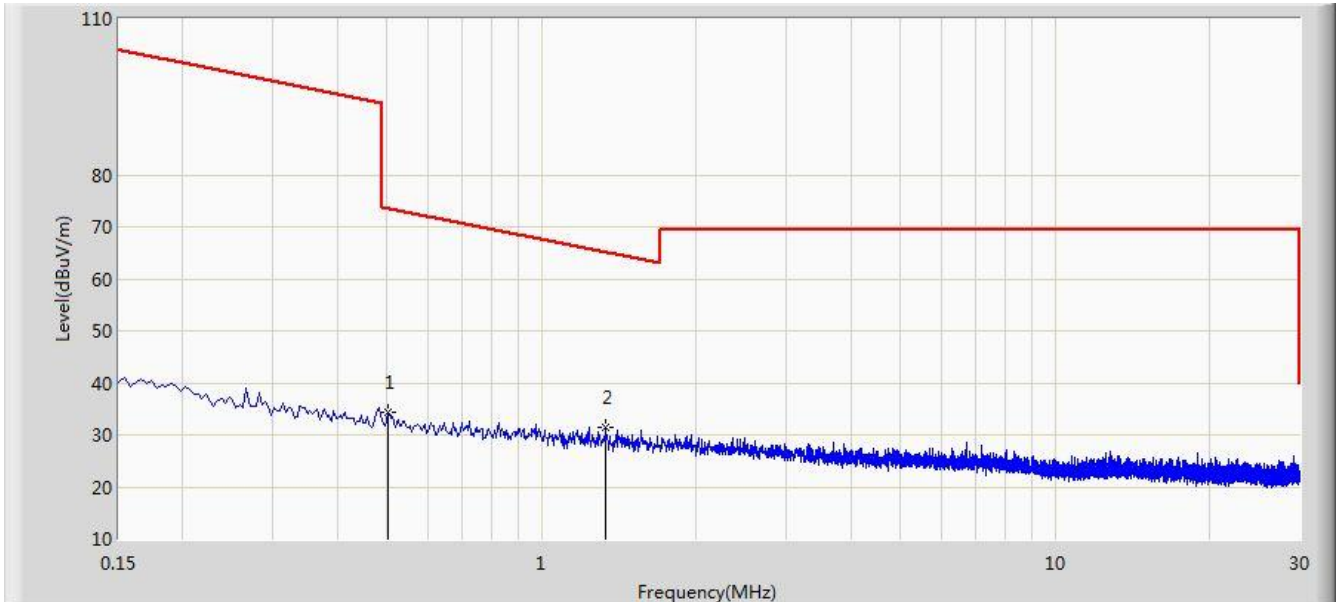

No	Flag	Mark	Frequency (MHz)	Measure Level (dBuV/m)	Reading Level (dBuV)	Over Limit (dB)	Limit (dBuV/m)	Factor (dB)	Type
1			0.502	34.370	13.947	-39.220	73.590	20.423	QP
2		*	1.334	31.595	11.104	-33.530	65.125	20.491	QP

Note: Measure Level (dBμV/m) = Reading Level (dBμV) + Factor (dB)

Factor (dB) = Cable Loss (dB) + Antenna Factor (dB/m)

Site: AC1	Time: 2016/07/15 - 10:21
Limit: FCC_Part15.209_RE(1m)	Engineer: Roy Cheng
Probe: BBHA9170_18-40GHz	Polarity: Horizontal
EUT: Wireless VOIP Router	Power: AC 120V/60Hz
<b>Note: There is the ambient noise within frequency range 18GHz~25GHz.</b>	

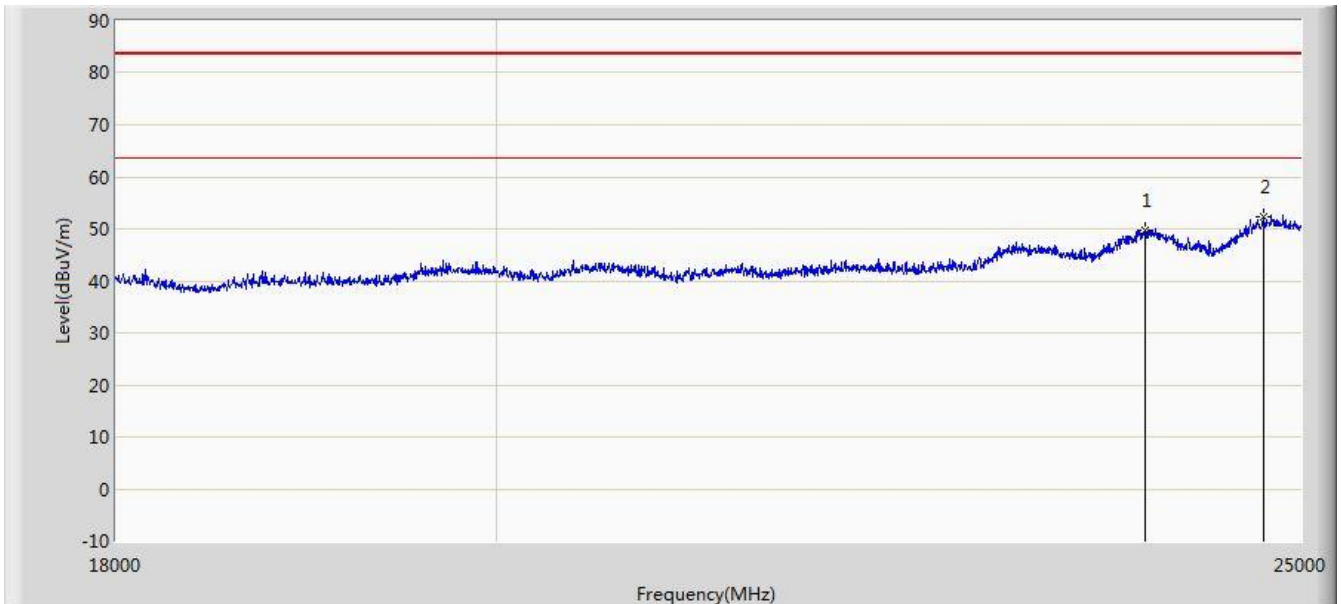

No	Flag	Mark	Frequency (MHz)	Measure Level (dBuV/m)	Reading Level (dBuV)	Over Limit (dB)	Limit (dBuV/m)	Factor (dB)	Type
1			23943.000	49.776	35.866	-33.724	83.500	13.910	PK
2		*	24741.000	52.375	37.681	-31.125	83.500	14.694	PK

Note: Measure Level (dB $\mu$ V/m) = Reading Level (dB $\mu$ V) + Factor (dB)

Factor (dB) = Cable Loss (dB) + Antenna Factor (dB/m) - Pre\_Amplifier Gain (dB)

Site: AC1	Time: 2016/07/15 - 10:21
Limit: FCC_Part15.209_RE(1m)	Engineer: Roy Cheng
Probe: BBHA9170_18-40GHz	Polarity: Vertical
EUT: Wireless VOIP Router	Power: AC 120V/60Hz
<b>Note: There is the ambient noise within frequency range 18GHz~25GHz.</b>	

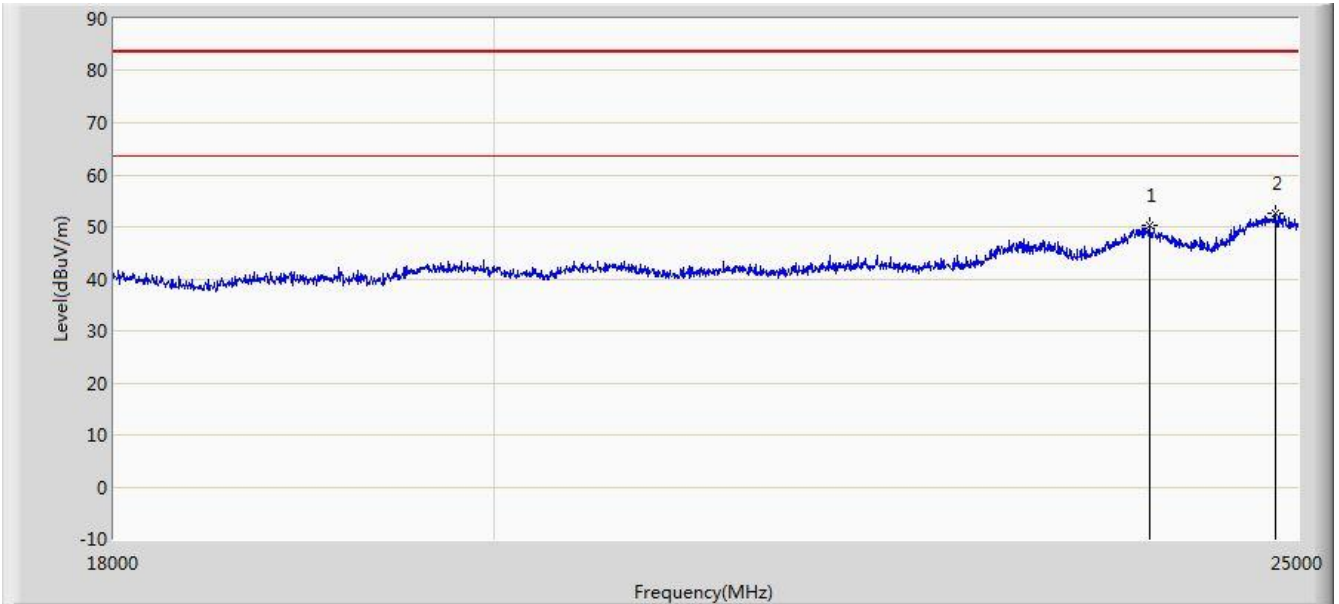

No	Flag	Mark	Frequency (MHz)	Measure Level (dBuV/m)	Reading Level (dBuV)	Over Limit (dB)	Limit (dBuV/m)	Factor (dB)	Type
1			23999.000	50.379	36.435	-33.121	83.500	13.944	PK
2		*	24846.000	52.503	37.735	-30.997	83.500	14.768	PK

Note: Measure Level (dB $\mu$ V/m) = Reading Level (dB $\mu$ V) + Factor (dB)

Factor (dB) = Cable Loss (dB) + Antenna Factor (dB/m) - Pre\_Amplifier Gain (dB)

Limit@1m = 20\*Log(500uV/m) + 20\*Log(3m/1m) = 63.5dB $\mu$ v/m (Average detector), and 83.5dB $\mu$ v/m (Peak detector).



## 7.7. Radiated Restricted Band Edge Measurement

### 7.7.1. Test Result

Site: AC1	Time: 2016/07/07 - 10:43
Limit: FCC_Part15.209_RE(3m)	Engineer: Vince Yu
Probe: BBHA9120D_1-18GHz	Polarity: Horizontal
EUT: Wireless VOIP Router	Power: AC 120V/60Hz
Test Mode: Transmit by 802.11b at Channel 2412MHz Ant 0	

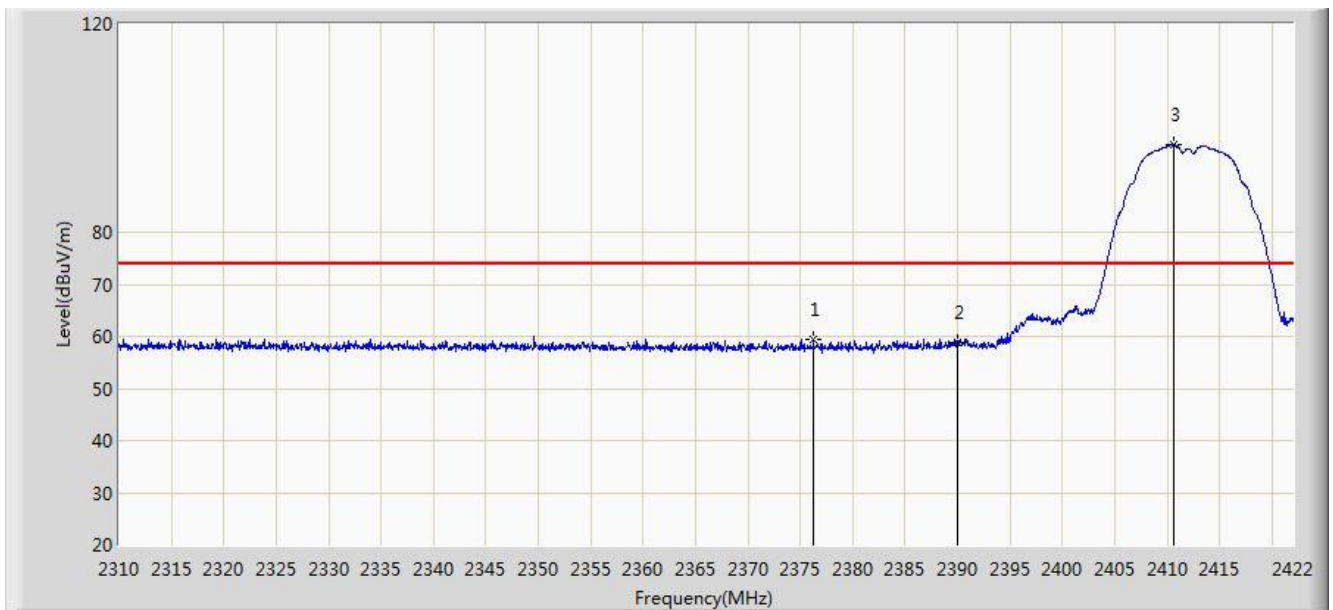

No	Flag	Mark	Frequency (MHz)	Measure Level (dBuV/m)	Reading Level (dBuV)	Over Limit (dB)	Limit (dBuV/m)	Factor (dB)	Type
1			2376.248	59.545	28.317	-14.455	74.000	31.228	PK
2			2390.000	58.861	27.658	-15.139	74.000	31.203	PK
3		*	2410.632	96.716	65.544	N/A	N/A	31.172	PK

Note: Measure Level (dB $\mu$ V/m) = Reading Level (dB $\mu$ V) + Factor (dB)

Factor (dB) = Cable Loss (dB) + Antenna Factor (dB/m)

Site: AC1	Time: 2016/07/07 - 10:45
Limit: FCC_Part15.209_RE(3m)	Engineer: Vince Yu
Probe: BBHA9120D_1-18GHz	Polarity: Horizontal
EUT: Wireless VOIP Router	Power: AC 120V/60Hz
Test Mode: Transmit by 802.11b at Channel 2412MHz Ant 0	

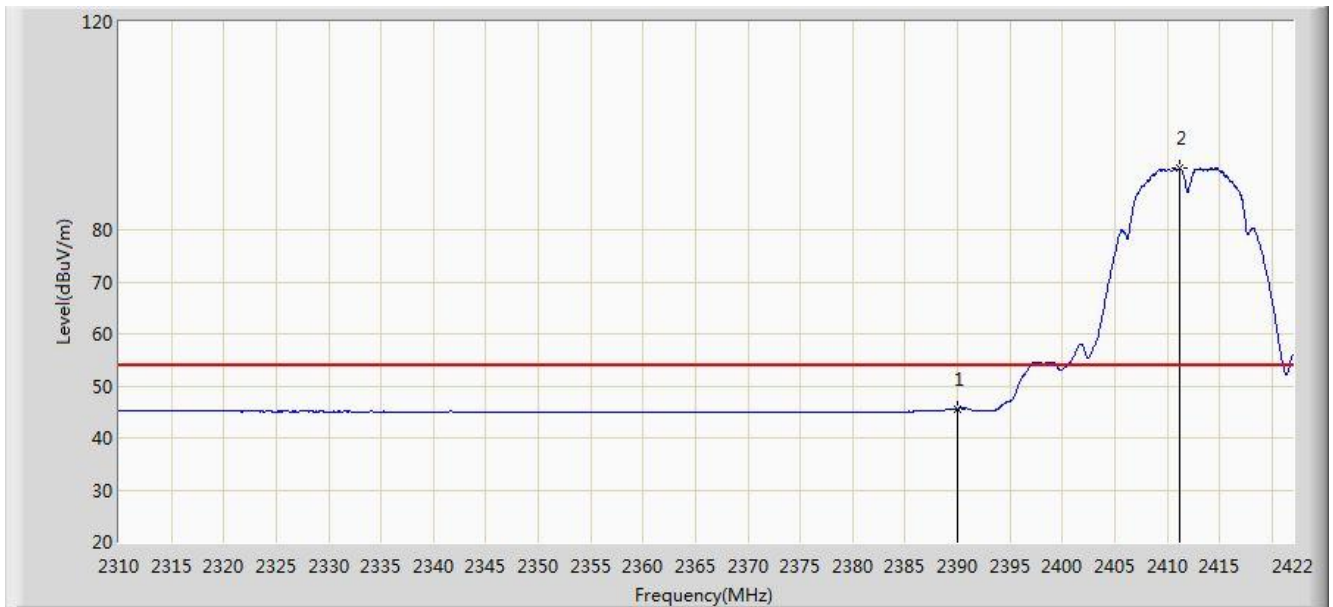

No	Flag	Mark	Frequency (MHz)	Measure Level (dBuV/m)	Reading Level (dBuV)	Over Limit (dB)	Limit (dBuV/m)	Factor (dB)	Type
1			2390.000	45.592	14.389	-8.408	54.000	31.203	AV
2		*	2411.248	91.859	60.688	N/A	N/A	31.171	AV

Note: Measure Level (dB $\mu$ V/m) = Reading Level (dB $\mu$ V) + Factor (dB)

Factor (dB) = Cable Loss (dB) + Antenna Factor (dB/m)

Site: AC1	Time: 2016/07/07 - 10:38
Limit: FCC_Part15.209_RE(3m)	Engineer: Vince Yu
Probe: BBHA9120D_1-18GHz	Polarity: Vertical
EUT: Wireless VOIP Router	Power: AC 120V/60Hz
Test Mode: Transmit by 802.11b at Channel 2412MHz Ant 0	

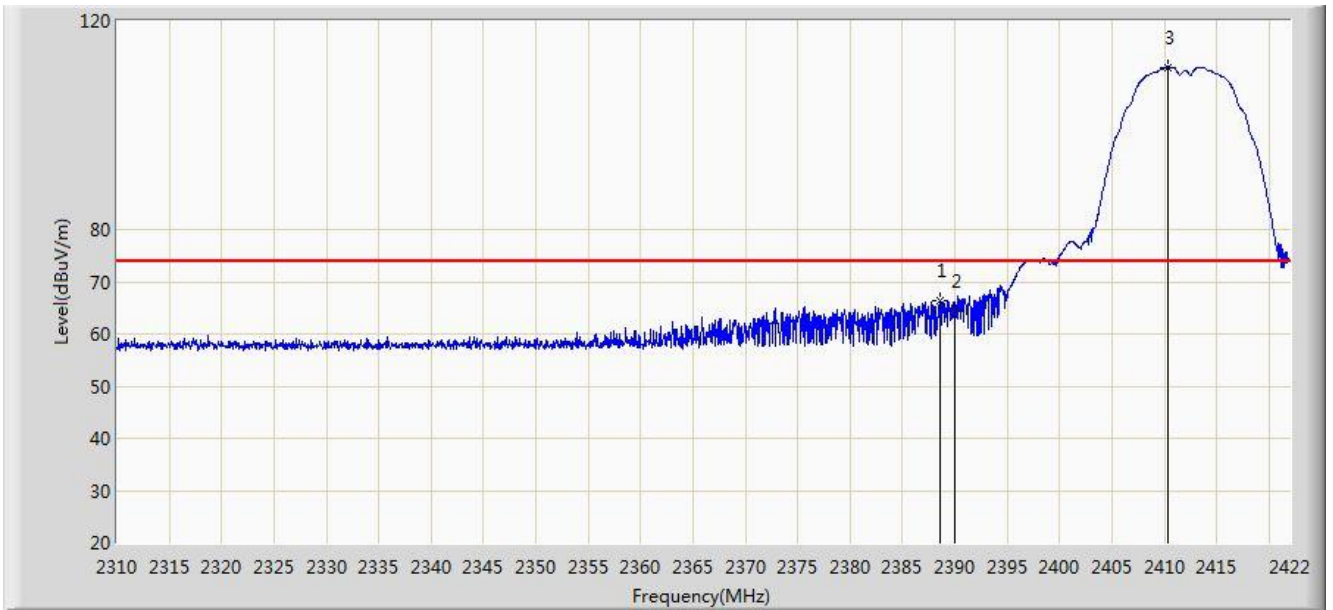

No	Flag	Mark	Frequency (MHz)	Measure Level (dBuV/m)	Reading Level (dBuV)	Over Limit (dB)	Limit (dBuV/m)	Factor (dB)	Type
1			2388.624	66.338	35.133	-7.662	74.000	31.205	PK
2			2390.000	64.279	33.076	-9.721	74.000	31.203	PK
3		*	2410.352	111.155	79.983	N/A	N/A	31.172	PK

Note: Measure Level (dB $\mu$ V/m) = Reading Level (dB $\mu$ V) + Factor (dB)

Factor (dB) = Cable Loss (dB) + Antenna Factor (dB/m)

Site: AC1	Time: 2016/07/07 - 10:38
Limit: FCC_Part15.209_RE(3m)	Engineer: Vince Yu
Probe: BBHA9120D_1-18GHz	Polarity: Vertical
EUT: Wireless VOIP Router	Power: AC 120V/60Hz
Test Mode: Transmit by 802.11b at Channel 2412MHz Ant 0	

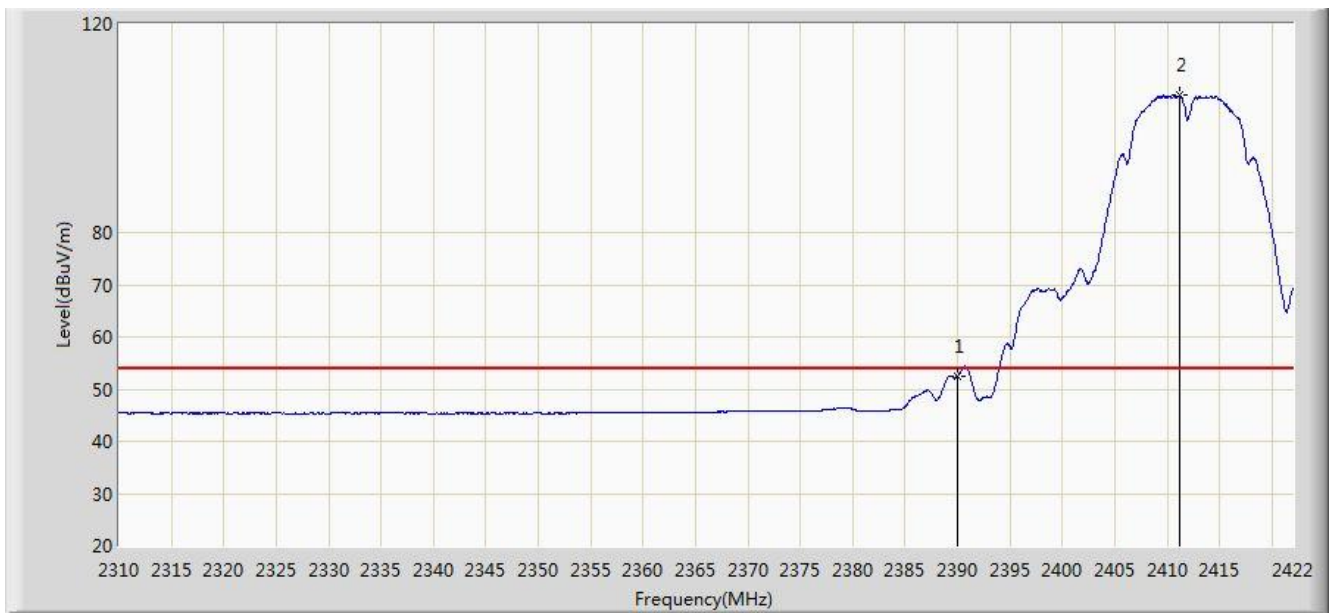

No	Flag	Mark	Frequency (MHz)	Measure Level (dBuV/m)	Reading Level (dBuV)	Over Limit (dB)	Limit (dBuV/m)	Factor (dB)	Type
1			2390.000	52.521	21.318	-1.479	54.000	31.203	AV
2		*	2411.192	106.267	75.096	N/A	N/A	31.171	AV

Note: Measure Level (dB $\mu$ V/m) = Reading Level (dB $\mu$ V) + Factor (dB)

Factor (dB) = Cable Loss (dB) + Antenna Factor (dB/m)

Site: AC1	Time: 2016/07/07 - 11:20
Limit: FCC_Part15.209_RE(3m)	Engineer: Vince Yu
Probe: BBHA9120D_1-18GHz	Polarity: Horizontal
EUT: Wireless VOIP Router	Power: AC 120V/60Hz
Test Mode: Transmit by 802.11b at Channel 2462MHz Ant 0	

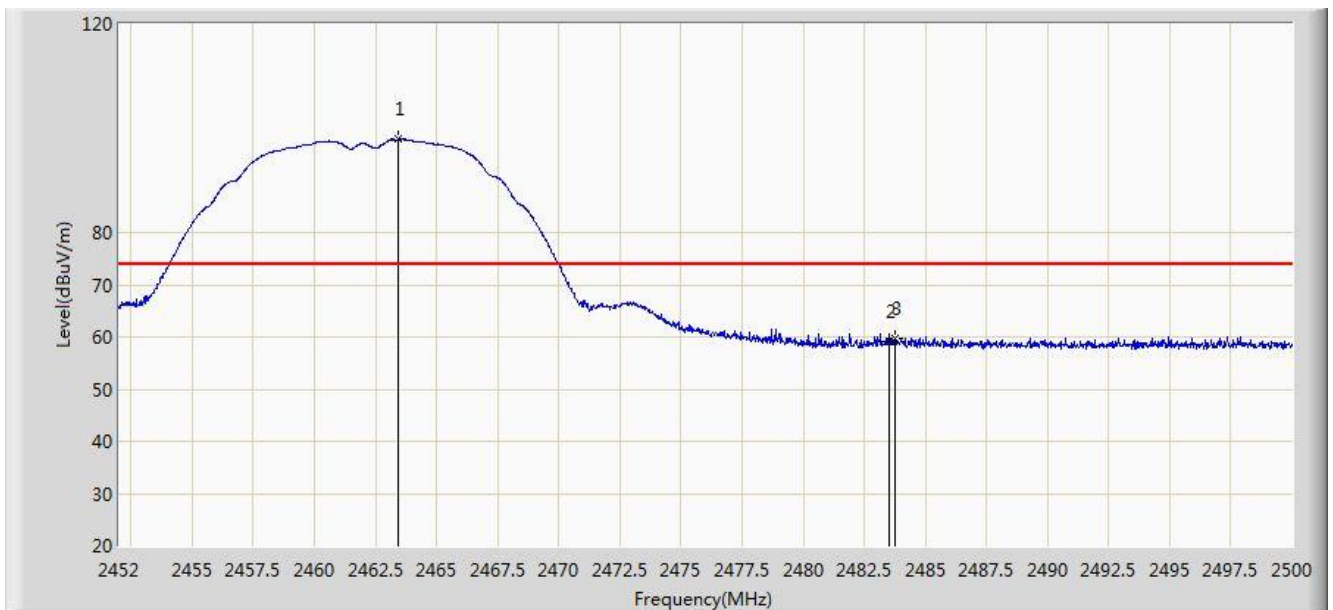

No	Flag	Mark	Frequency (MHz)	Measure Level (dBuV/m)	Reading Level (dBuV)	Over Limit (dB)	Limit (dBuV/m)	Factor (dB)	Type
1		*	2463.424	97.902	66.764	N/A	N/A	31.138	PK
2			2483.500	59.260	28.067	-14.740	74.000	31.194	PK
3			2483.776	59.735	28.541	-14.265	74.000	31.194	PK

Note: Measure Level (dB $\mu$ V/m) = Reading Level (dB $\mu$ V) + Factor (dB)

Factor (dB) = Cable Loss (dB) + Antenna Factor (dB/m)

Site: AC1	Time: 2016/07/07 - 11:27
Limit: FCC_Part15.209_RE(3m)	Engineer: Vince Yu
Probe: BBHA9120D_1-18GHz	Polarity: Horizontal
EUT: Wireless VOIP Router	Power: AC 120V/60Hz
Test Mode: Transmit by 802.11b at Channel 2462MHz Ant 0	

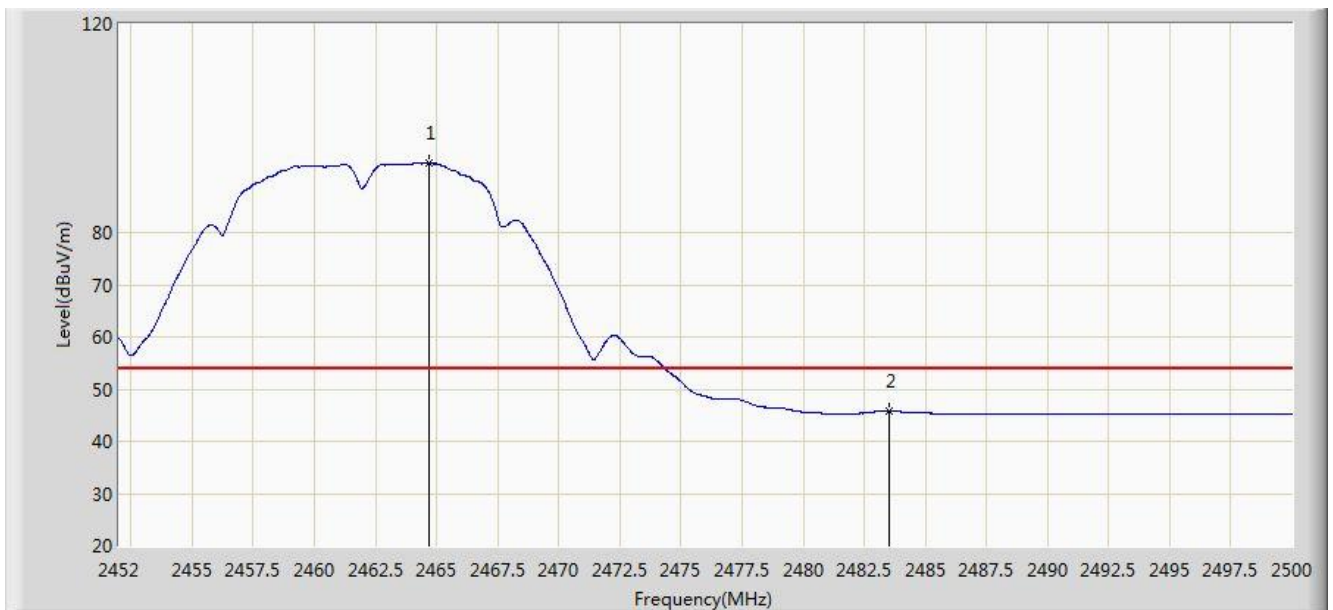

No	Flag	Mark	Frequency (MHz)	Measure Level (dBuV/m)	Reading Level (dBuV)	Over Limit (dB)	Limit (dBuV/m)	Factor (dB)	Type
1		*	2464.720	93.429	62.288	N/A	N/A	31.142	AV
2			2483.500	45.779	14.586	-8.221	54.000	31.194	AV

Note: Measure Level (dBuV/m) = Reading Level (dBuV) + Factor (dB)

Factor (dB) = Cable Loss (dB) + Antenna Factor (dB/m)

Site: AC1	Time: 2016/07/07 - 11:18
Limit: FCC_Part15.209_RE(3m)	Engineer: Vince Yu
Probe: BBHA9120D_1-18GHz	Polarity: Vertical
EUT: Wireless VOIP Router	Power: AC 120V/60Hz
Test Mode: Transmit by 802.11b at Channel 2462MHz Ant 0	

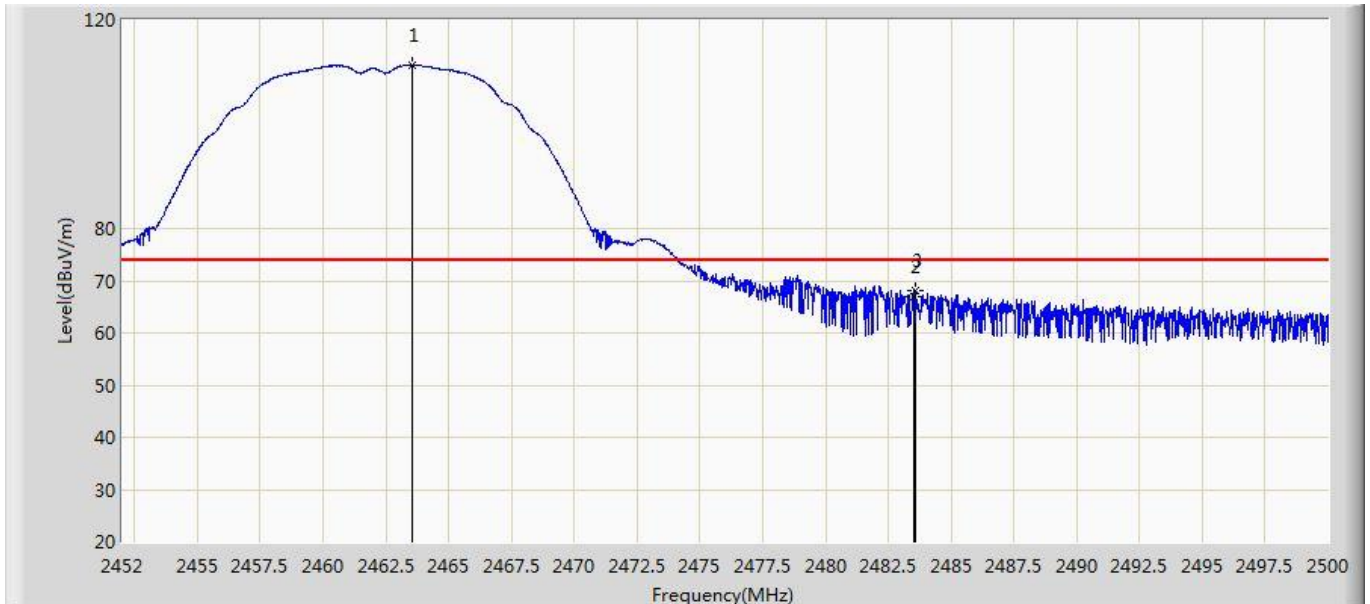

No	Flag	Mark	Frequency (MHz)	Measure Level (dBuV/m)	Reading Level (dBuV)	Over Limit (dB)	Limit (dBuV/m)	Factor (dB)	Type
1		*	2463.544	111.408	80.270	N/A	N/A	31.139	PK
2			2483.500	66.964	35.771	-7.036	74.000	31.194	PK
3			2483.608	68.082	36.888	-5.918	74.000	31.194	PK

Note: Measure Level (dB $\mu$ V/m) = Reading Level (dB $\mu$ V) + Factor (dB)

Factor (dB) = Cable Loss (dB) + Antenna Factor (dB/m)

Site: AC1	Time: 2016/07/07 - 11:14
Limit: FCC_Part15.209_RE(3m)	Engineer: Vince Yu
Probe: BBHA9120D_1-18GHz	Polarity: Vertical
EUT: Wireless VOIP Router	Power: AC 120V/60Hz
Test Mode: Transmit by 802.11b at Channel 2462MHz Ant 0	



No	Flag	Mark	Frequency (MHz)	Measure Level (dBuV/m)	Reading Level (dBuV)	Over Limit (dB)	Limit (dBuV/m)	Factor (dB)	Type
1		*	2464.672	106.586	75.445	N/A	N/A	31.142	AV
2			2483.500	52.684	21.491	-1.316	54.000	31.194	AV

Note: Measure Level (dBuV/m) = Reading Level (dBuV) + Factor (dB)

Factor (dB) = Cable Loss (dB) + Antenna Factor (dB/m)



Site: AC1	Time: 2016/07/07 - 11:48
Limit: FCC_Part15.209_RE(3m)	Engineer: Vince Yu
Probe: BBHA9120D_1-18GHz	Polarity: Horizontal
EUT: Wireless VOIP Router	Power: AC 120V/60Hz
Test Mode: Transmit by 802.11g at Channel 2412MHz Ant 0	

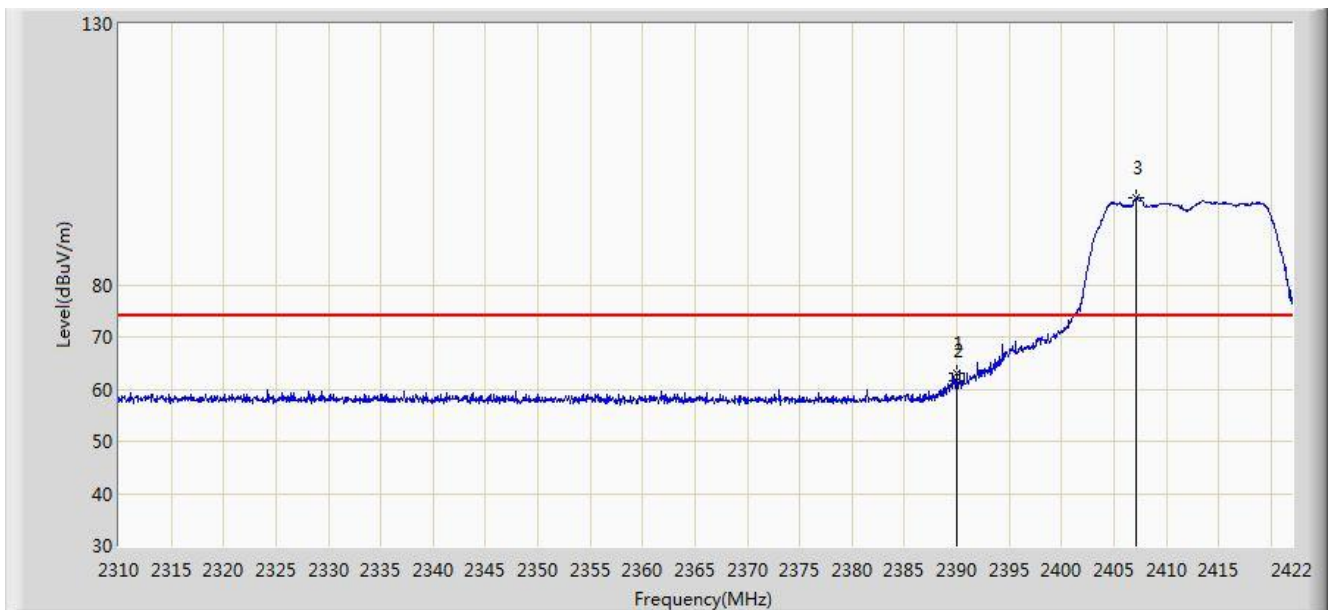

No	Flag	Mark	Frequency (MHz)	Measure Level (dBuV/m)	Reading Level (dBuV)	Over Limit (dB)	Limit (dBuV/m)	Factor (dB)	Type
1			2389.968	63.121	31.918	-10.879	74.000	31.203	PK
2			2390.000	61.594	30.391	-12.406	74.000	31.203	PK
3		*	2407.160	96.622	65.445	N/A	N/A	31.177	PK

Note: Measure Level (dB $\mu$ V/m) = Reading Level (dB $\mu$ V) + Factor (dB)

Factor (dB) = Cable Loss (dB) + Antenna Factor (dB/m)

Site: AC1	Time: 2016/07/07 - 11:52
Limit: FCC_Part15.209_RE(3m)	Engineer: Vince Yu
Probe: BBHA9120D_1-18GHz	Polarity: Horizontal
EUT: Wireless VOIP Router	Power: AC 120V/60Hz
Test Mode: Transmit by 802.11g at Channel 2412MHz Ant 0	

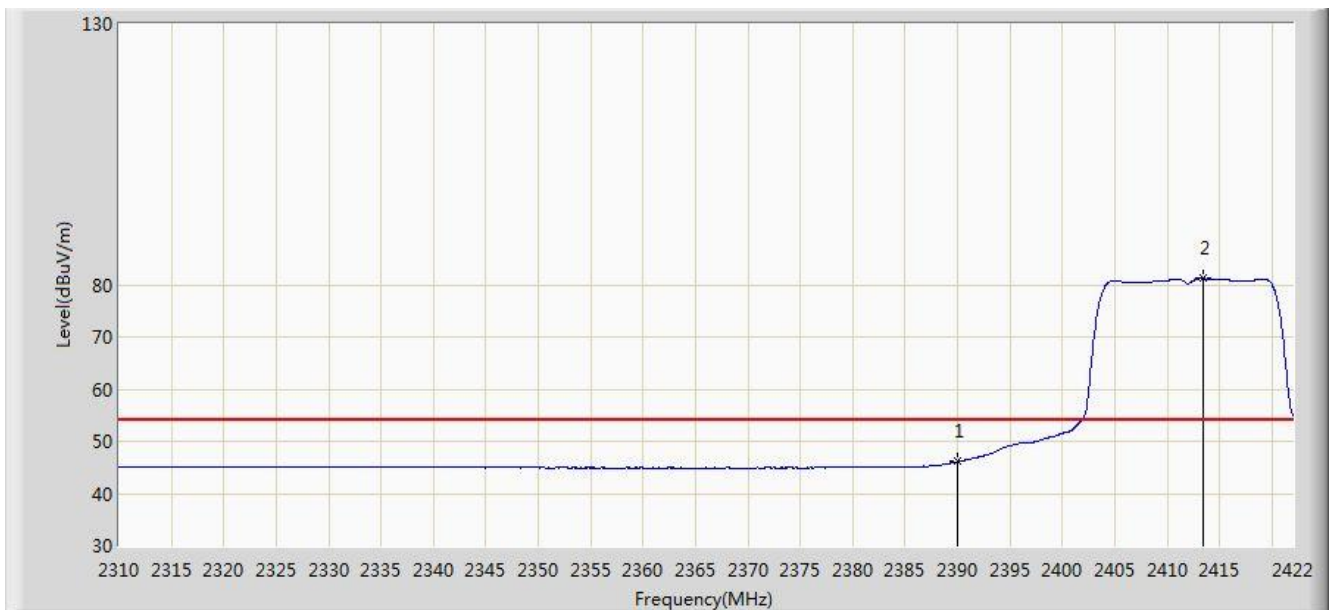

No	Flag	Mark	Frequency (MHz)	Measure Level (dBuV/m)	Reading Level (dBuV)	Over Limit (dB)	Limit (dBuV/m)	Factor (dB)	Type
1			2390.000	46.130	14.927	-7.870	54.000	31.203	AV
2		*	2413.376	81.241	50.074	N/A	N/A	31.168	AV

Note: Measure Level (dBuV/m) = Reading Level (dBuV) + Factor (dB)

Factor (dB) = Cable Loss (dB) + Antenna Factor (dB/m)

Site: AC1	Time: 2016/07/07 - 11:47
Limit: FCC_Part15.209_RE(3m)	Engineer: Vince Yu
Probe: BBHA9120D_1-18GHz	Polarity: Vertical
EUT: Wireless VOIP Router	Power: AC 120V/60Hz
Test Mode: Transmit by 802.11g at Channel 2412MHz Ant 0	

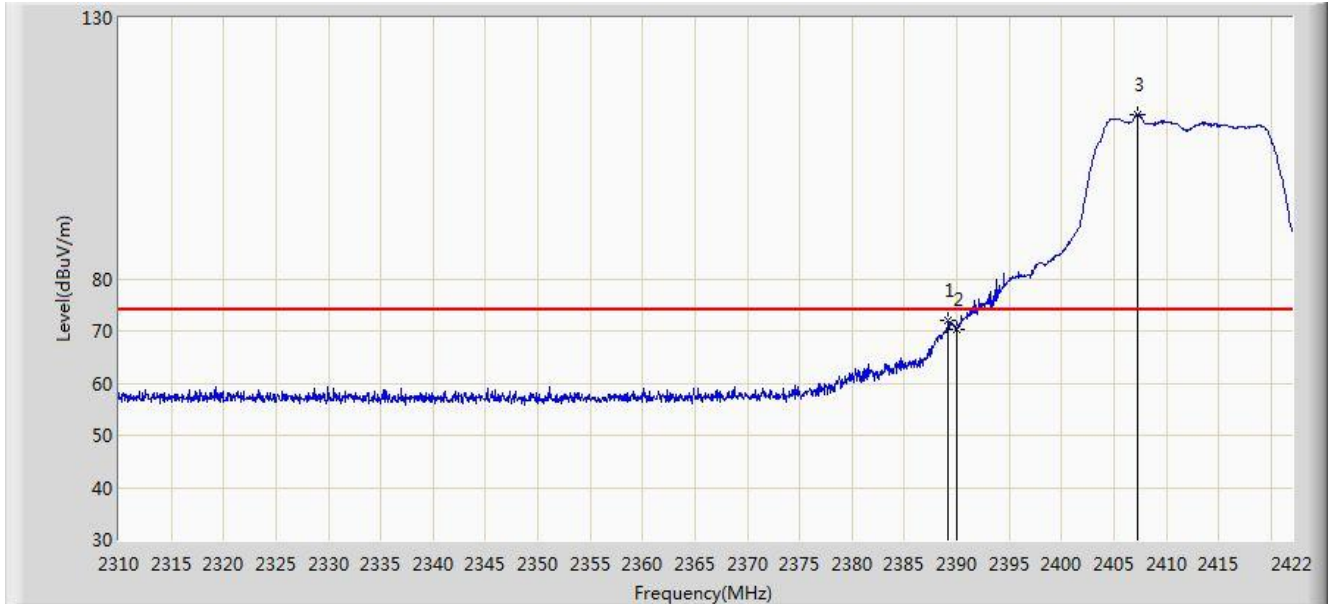

No	Flag	Mark	Frequency (MHz)	Measure Level (dBuV/m)	Reading Level (dBuV)	Over Limit (dB)	Limit (dBuV/m)	Factor (dB)	Type
1			2389.184	72.072	40.868	-1.928	74.000	31.204	PK
2			2390.000	70.310	39.107	-3.690	74.000	31.203	PK
3		*	2407.328	111.455	80.279	N/A	N/A	31.176	PK

Note: Measure Level (dB $\mu$ V/m) = Reading Level (dB $\mu$ V) + Factor (dB)

Factor (dB) = Cable Loss (dB) + Antenna Factor (dB/m)

Site: AC1	Time: 2016/07/07 - 11:46
Limit: FCC_Part15.209_RE(3m)	Engineer: Vince Yu
Probe: BBHA9120D_1-18GHz	Polarity: Vertical
EUT: Wireless VOIP Router	Power: AC 120V/60Hz
Test Mode: Transmit by 802.11g at Channel 2412MHz Ant 0	

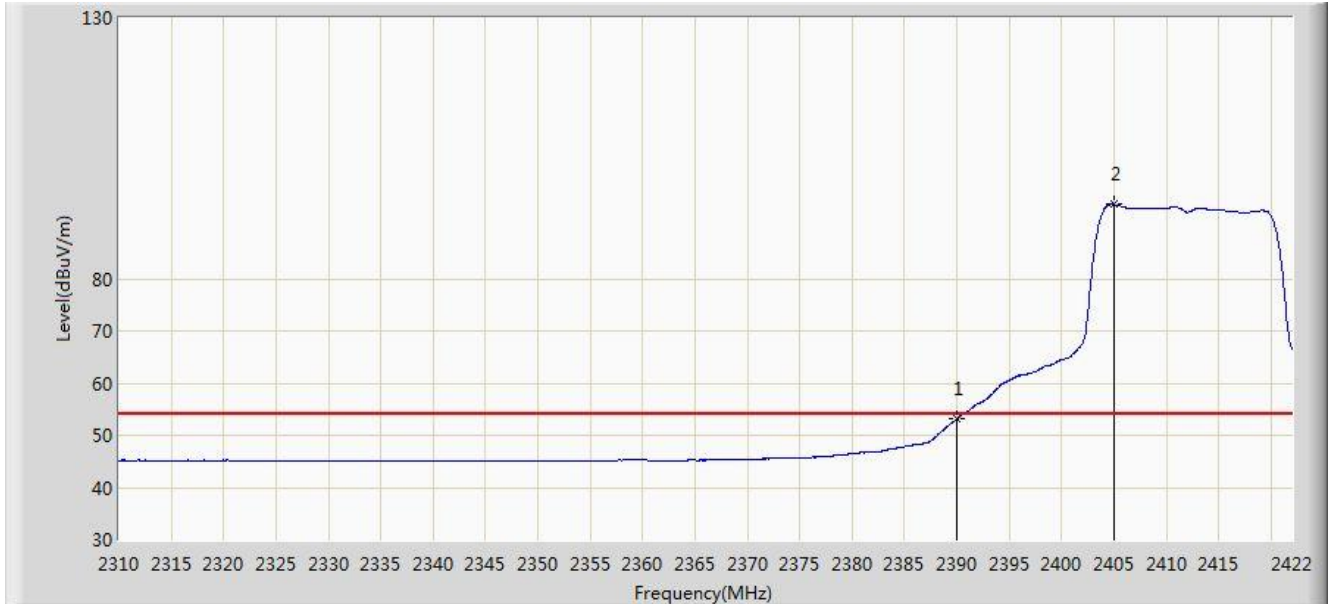

No	Flag	Mark	Frequency (MHz)	Measure Level (dBuV/m)	Reading Level (dBuV)	Over Limit (dB)	Limit (dBuV/m)	Factor (dB)	Type
1			2390.000	53.115	21.912	-0.885	54.000	31.203	AV
2		*	2405.032	94.212	63.032	N/A	N/A	31.180	AV

Note: Measure Level (dB $\mu$ V/m) = Reading Level (dB $\mu$ V) + Factor (dB)

Factor (dB) = Cable Loss (dB) + Antenna Factor (dB/m)

Site: AC1	Time: 2016/07/11 - 09:59
Limit: FCC_Part15.209_RE(3m)	Engineer: Vince Yu
Probe: BBHA9120D_1-18GHz	Polarity: Horizontal
EUT: Wireless VOIP Router	Power: AC 120V/60Hz
Test Mode: Transmit by 802.11g at Channel 2462MHz Ant 0	



No	Flag	Mark	Frequency (MHz)	Measure Level (dBuV/m)	Reading Level (dBuV)	Over Limit (dB)	Limit (dBuV/m)	Factor (dB)	Type
1		*	2457.520	95.483	64.356	N/A	N/A	31.127	PK
2			2483.500	60.834	29.641	-13.166	74.000	31.194	PK

Note: Measure Level (dB $\mu$ V/m) = Reading Level (dB $\mu$ V) + Factor (dB)

Factor (dB) = Cable Loss (dB) + Antenna Factor (dB/m)

Site: AC1	Time: 2016/07/11 - 10:02
Limit: FCC_Part15.209_RE(3m)	Engineer: Vince Yu
Probe: BBHA9120D_1-18GHz	Polarity: Horizontal
EUT: Wireless VOIP Router	Power: AC 120V/60Hz
Test Mode: Transmit by 802.11g at Channel 2462MHz Ant 0	

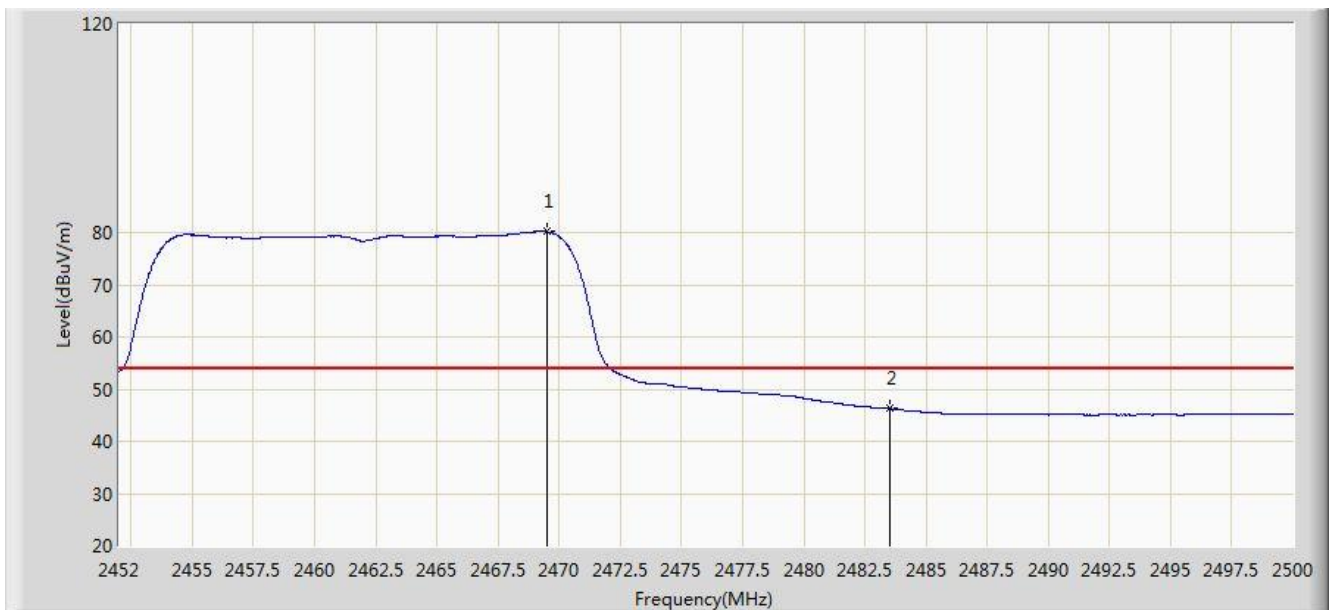

No	Flag	Mark	Frequency (MHz)	Measure Level (dBuV/m)	Reading Level (dBuV)	Over Limit (dB)	Limit (dBuV/m)	Factor (dB)	Type
1		*	2469.520	80.162	49.007	N/A	N/A	31.155	AV
2			2483.500	46.259	15.066	-7.741	54.000	31.194	AV

Note: Measure Level (dB $\mu$ V/m) = Reading Level (dB $\mu$ V) + Factor (dB)

Factor (dB) = Cable Loss (dB) + Antenna Factor (dB/m)

Site: AC1	Time: 2016/07/07 - 12:05
Limit: FCC_Part15.209_RE(3m)	Engineer: Vince Yu
Probe: BBHA9120D_1-18GHz	Polarity: Vertical
EUT: Wireless VOIP Router	Power: AC 120V/60Hz
Test Mode: Transmit by 802.11g at Channel 2462MHz Ant 0	



No	Flag	Mark	Frequency (MHz)	Measure Level (dBuV/m)	Reading Level (dBuV)	Over Limit (dB)	Limit (dBuV/m)	Factor (dB)	Type
1		*	2457.448	108.981	77.854	N/A	N/A	31.127	PK
2			2483.500	69.330	38.137	-4.670	74.000	31.194	PK
3			2484.304	70.713	39.518	-3.287	74.000	31.195	PK

Note: Measure Level (dB $\mu$ V/m) = Reading Level (dB $\mu$ V) + Factor (dB)

Factor (dB) = Cable Loss (dB) + Antenna Factor (dB/m)

Site: AC1	Time: 2016/07/07 - 12:06
Limit: FCC_Part15.209_RE(3m)	Engineer: Vince Yu
Probe: BBHA9120D_1-18GHz	Polarity: Vertical
EUT: Wireless VOIP Router	Power: AC 120V/60Hz
Test Mode: Transmit by 802.11g at Channel 2462MHz Ant 0	

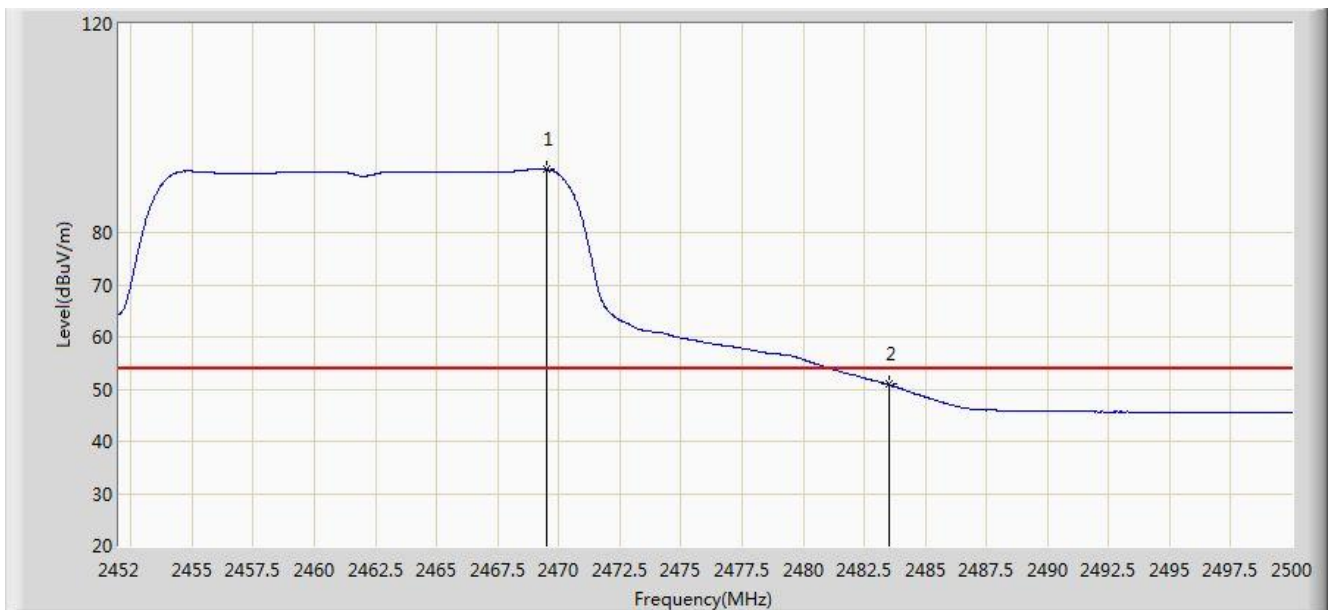

No	Flag	Mark	Frequency (MHz)	Measure Level (dBuV/m)	Reading Level (dBuV)	Over Limit (dB)	Limit (dBuV/m)	Factor (dB)	Type
1		*	2469.520	92.078	60.923	N/A	N/A	31.155	AV
2			2483.500	50.950	19.757	-3.050	54.000	31.194	AV

Note: Measure Level (dB $\mu$ V/m) = Reading Level (dB $\mu$ V) + Factor (dB)

Factor (dB) = Cable Loss (dB) + Antenna Factor (dB/m)



Site: AC1	Time: 2016/07/11 - 19:45
Limit: FCC_Part15.209_RE(3m)	Engineer: Vince Yu
Probe: BBHA9120D_1-18GHz	Polarity: Horizontal
EUT: Wireless VOIP Router	Power: AC 120V/60Hz
Test Mode: Transmit by 802.11b at Channel 2412MHz Ant 1	

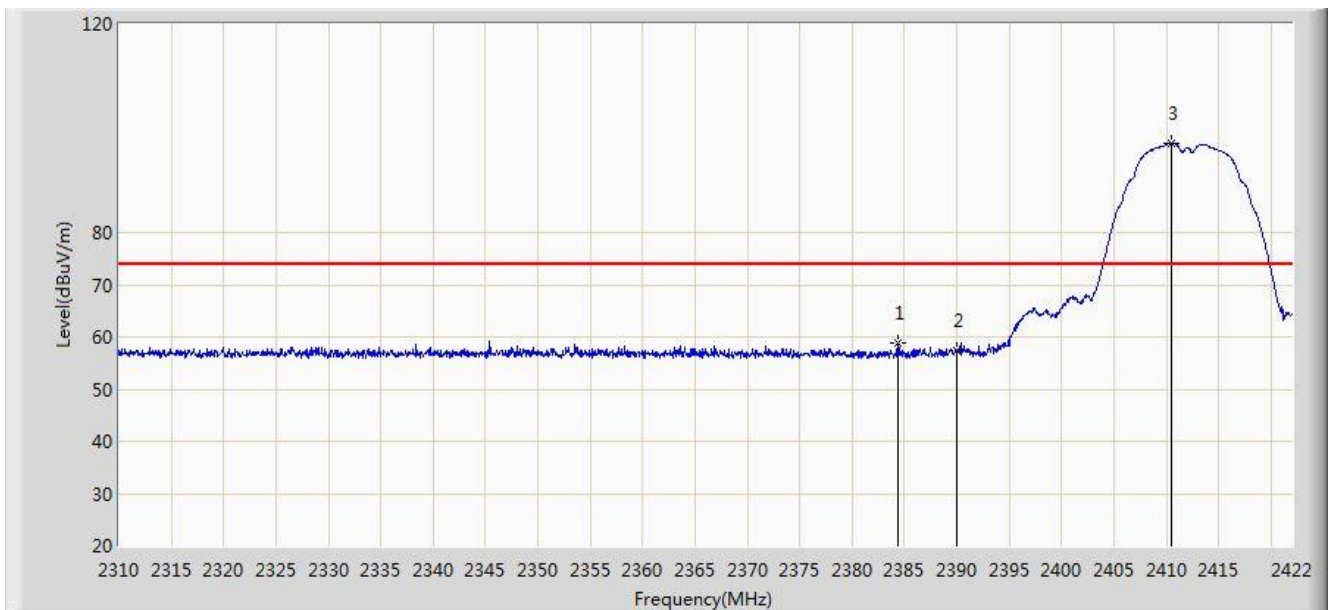

No	Flag	Mark	Frequency (MHz)	Measure Level (dBuV/m)	Reading Level (dBuV)	Over Limit (dB)	Limit (dBuV/m)	Factor (dB)	Type
1			2384.368	58.760	27.547	-15.240	74.000	31.213	PK
2			2390.000	57.306	26.103	-16.694	74.000	31.203	PK
3		*	2410.464	97.070	65.898	N/A	N/A	31.172	PK

Note: Measure Level (dB $\mu$ V/m) = Reading Level (dB $\mu$ V) + Factor (dB)

Factor (dB) = Cable Loss (dB) + Antenna Factor (dB/m)

Site: AC1	Time: 2016/07/11 - 19:46
Limit: FCC_Part15.209_RE(3m)	Engineer: Vince Yu
Probe: BBHA9120D_1-18GHz	Polarity: Horizontal
EUT: Wireless VOIP Router	Power: AC 120V/60Hz
Test Mode: Transmit by 802.11b at Channel 2412MHz Ant 1	

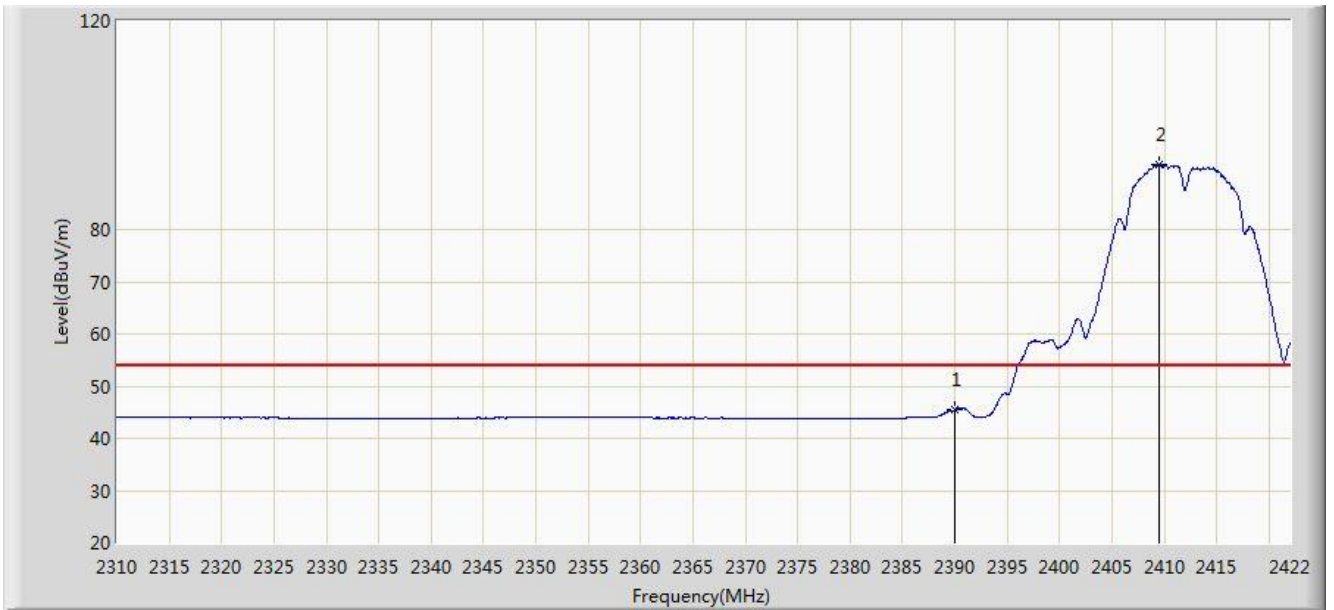

No	Flag	Mark	Frequency (MHz)	Measure Level (dBuV/m)	Reading Level (dBuV)	Over Limit (dB)	Limit (dBuV/m)	Factor (dB)	Type
1			2390.000	45.368	14.165	-8.632	54.000	31.203	AV
2		*	2409.456	92.319	61.146	N/A	N/A	31.173	AV

Note: Measure Level (dB $\mu$ V/m) = Reading Level (dB $\mu$ V) + Factor (dB)

Factor (dB) = Cable Loss (dB) + Antenna Factor (dB/m)

Site: AC1	Time: 2016/07/11 - 19:42
Limit: FCC_Part15.209_RE(3m)	Engineer: Vince Yu
Probe: BBHA9120D_1-18GHz	Polarity: Vertical
EUT: Wireless VOIP Router	Power: AC 120V/60Hz
Test Mode: Transmit by 802.11b at Channel 2412MHz Ant 1	

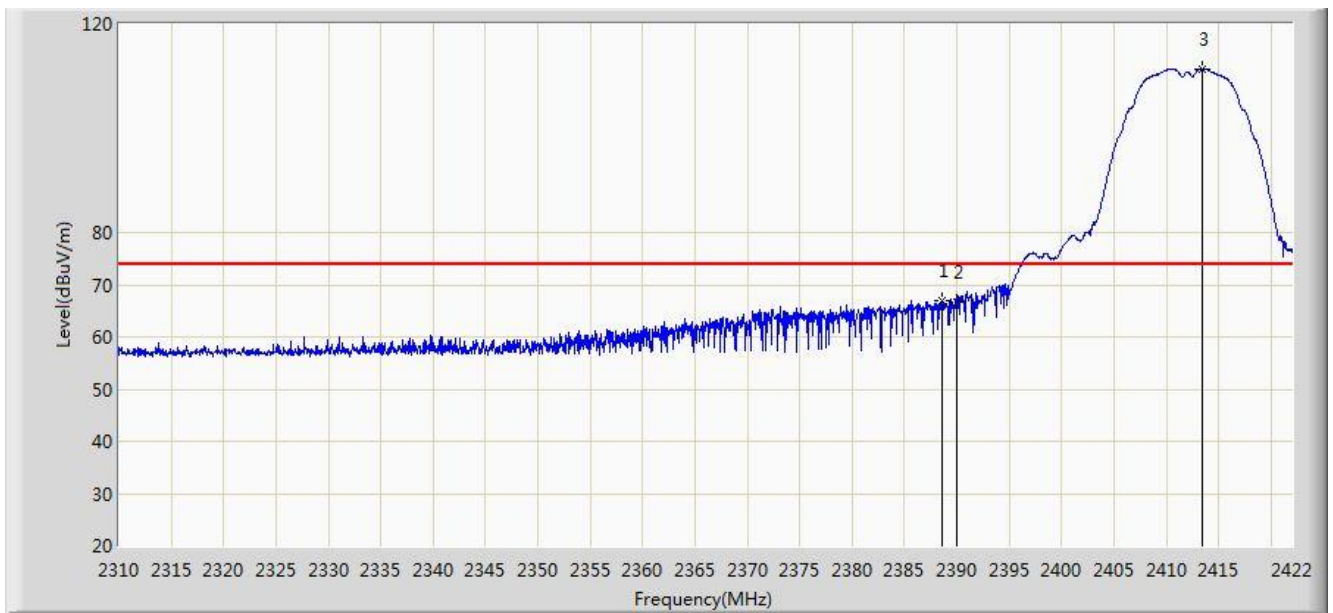

No	Flag	Mark	Frequency (MHz)	Measure Level (dBuV/m)	Reading Level (dBuV)	Over Limit (dB)	Limit (dBuV/m)	Factor (dB)	Type
1			2388.568	66.952	35.747	-7.048	74.000	31.206	PK
2			2390.000	66.790	35.587	-7.210	74.000	31.203	PK
3		*	2413.432	111.323	80.156	N/A	N/A	31.168	PK

Note: Measure Level (dB $\mu$ V/m) = Reading Level (dB $\mu$ V) + Factor (dB)

Factor (dB) = Cable Loss (dB) + Antenna Factor (dB/m)

Site: AC1	Time: 2016/07/11 - 19:44
Limit: FCC_Part15.209_RE(3m)	Engineer: Vince Yu
Probe: BBHA9120D_1-18GHz	Polarity: Vertical
EUT: Wireless VOIP Router	Power: AC 120V/60Hz
Test Mode: Transmit by 802.11b at Channel 2412MHz Ant 1	

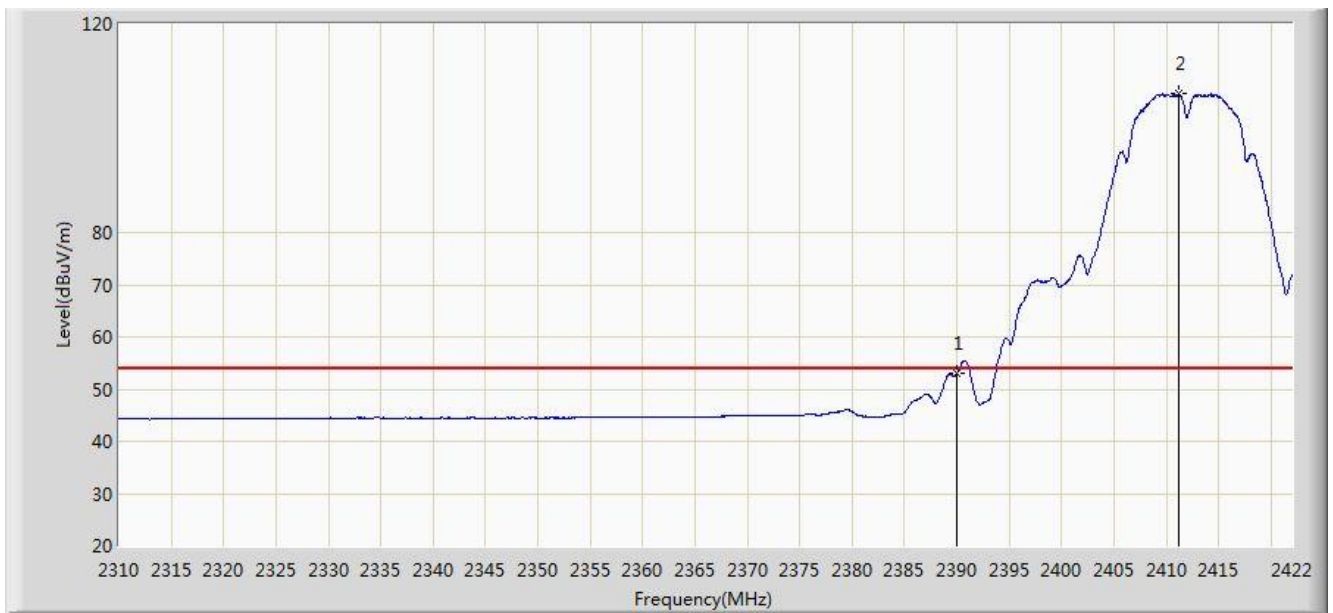

No	Flag	Mark	Frequency (MHz)	Measure Level (dBuV/m)	Reading Level (dBuV)	Over Limit (dB)	Limit (dBuV/m)	Factor (dB)	Type
1			2390.000	53.045	21.842	-0.955	54.000	31.203	AV
2		*	2411.136	106.564	75.393	N/A	N/A	31.171	AV

Note: Measure Level (dB $\mu$ V/m) = Reading Level (dB $\mu$ V) + Factor (dB)

Factor (dB) = Cable Loss (dB) + Antenna Factor (dB/m)

Site: AC1	Time: 2016/07/11 - 19:49
Limit: FCC_Part15.209_RE(3m)	Engineer: Vince Yu
Probe: BBHA9120D_1-18GHz	Polarity: Horizontal
EUT: Wireless VOIP Router	Power: AC 120V/60Hz
Test Mode: Transmit by 802.11b at Channel 2462MHz Ant 1	

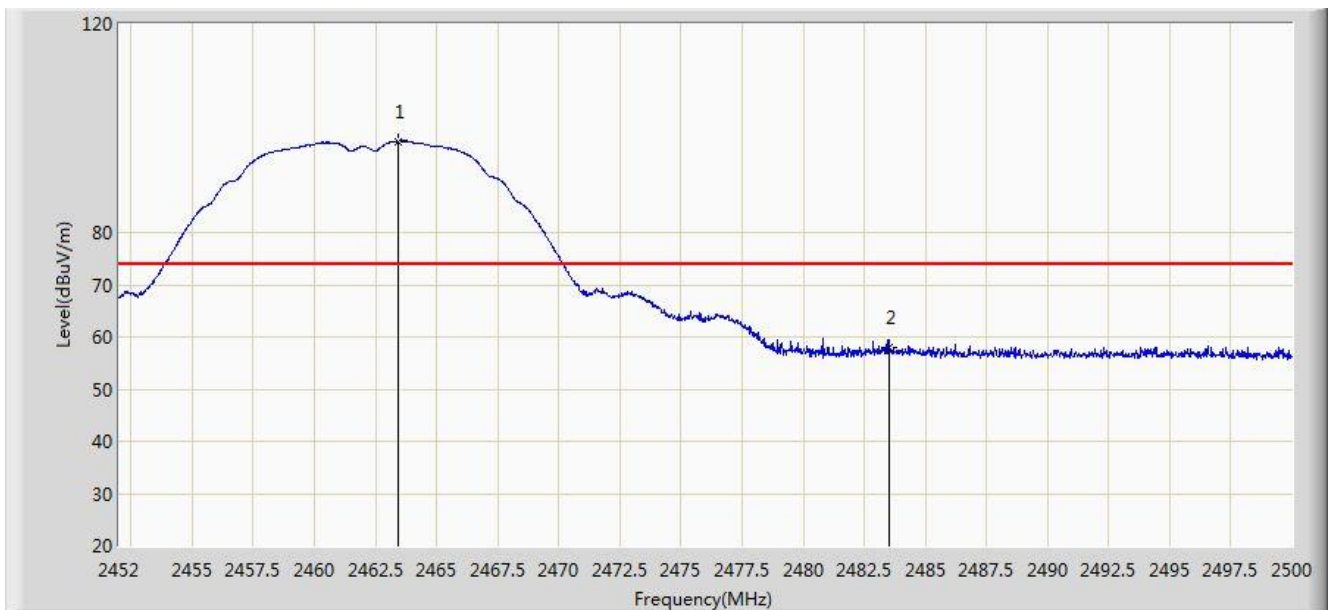

No	Flag	Mark	Frequency (MHz)	Measure Level (dBuV/m)	Reading Level (dBuV)	Over Limit (dB)	Limit (dBuV/m)	Factor (dB)	Type
1		*	2463.400	97.497	66.359	N/A	N/A	31.138	PK
2			2483.500	58.098	26.905	-15.902	74.000	31.194	PK

Note: Measure Level (dBuV/m) = Reading Level (dBuV) + Factor (dB)

Factor (dB) = Cable Loss (dB) + Antenna Factor (dB/m)

Site: AC1	Time: 2016/07/11 - 19:51
Limit: FCC_Part15.209_RE(3m)	Engineer: Vince Yu
Probe: BBHA9120D_1-18GHz	Polarity: Horizontal
EUT: Wireless VOIP Router	Power: AC 120V/60Hz
Test Mode: Transmit by 802.11b at Channel 2462MHz Ant 1	

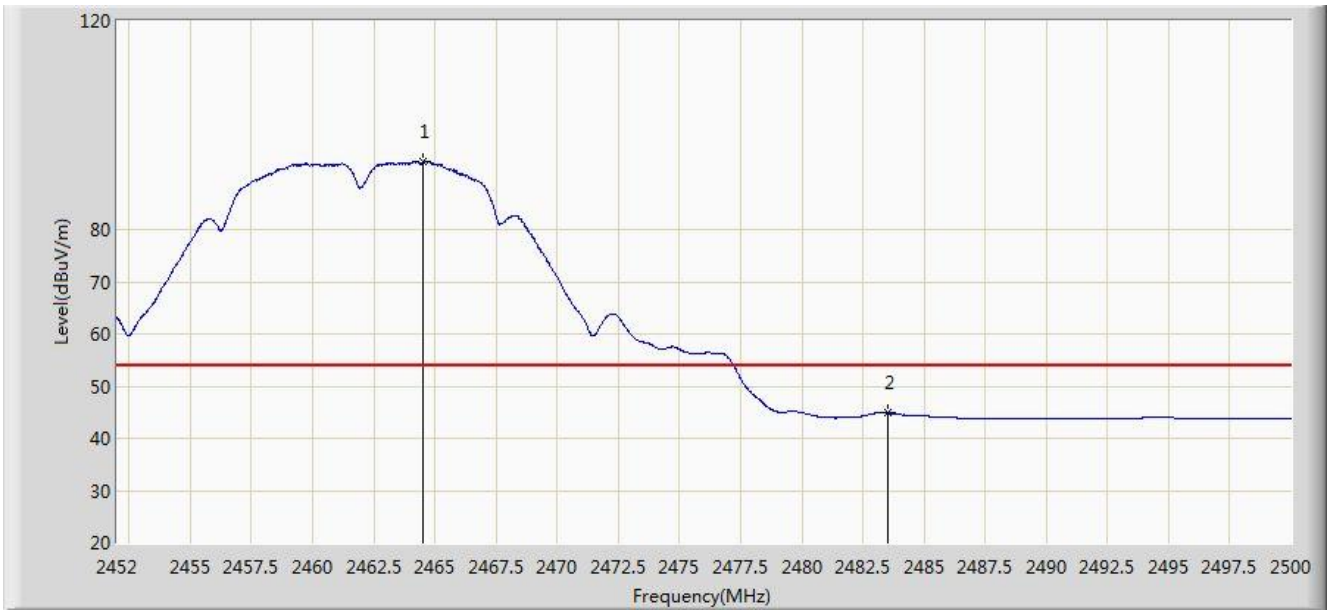

No	Flag	Mark	Frequency (MHz)	Measure Level (dBuV/m)	Reading Level (dBuV)	Over Limit (dB)	Limit (dBuV/m)	Factor (dB)	Type
1		*	2464.504	92.909	61.768	N/A	N/A	31.141	AV
2			2483.500	44.902	13.709	-9.098	54.000	31.194	AV

Note: Measure Level (dBuV/m) = Reading Level (dBuV) + Factor (dB)

Factor (dB) = Cable Loss (dB) + Antenna Factor (dB/m)

Site: AC1	Time: 2016/07/11 - 19:47
Limit: FCC_Part15.209_RE(3m)	Engineer: Vince Yu
Probe: BBHA9120D_1-18GHz	Polarity: Vertical
EUT: Wireless VOIP Router	Power: AC 120V/60Hz
Test Mode: Transmit by 802.11b at Channel 2462MHz Ant 1	

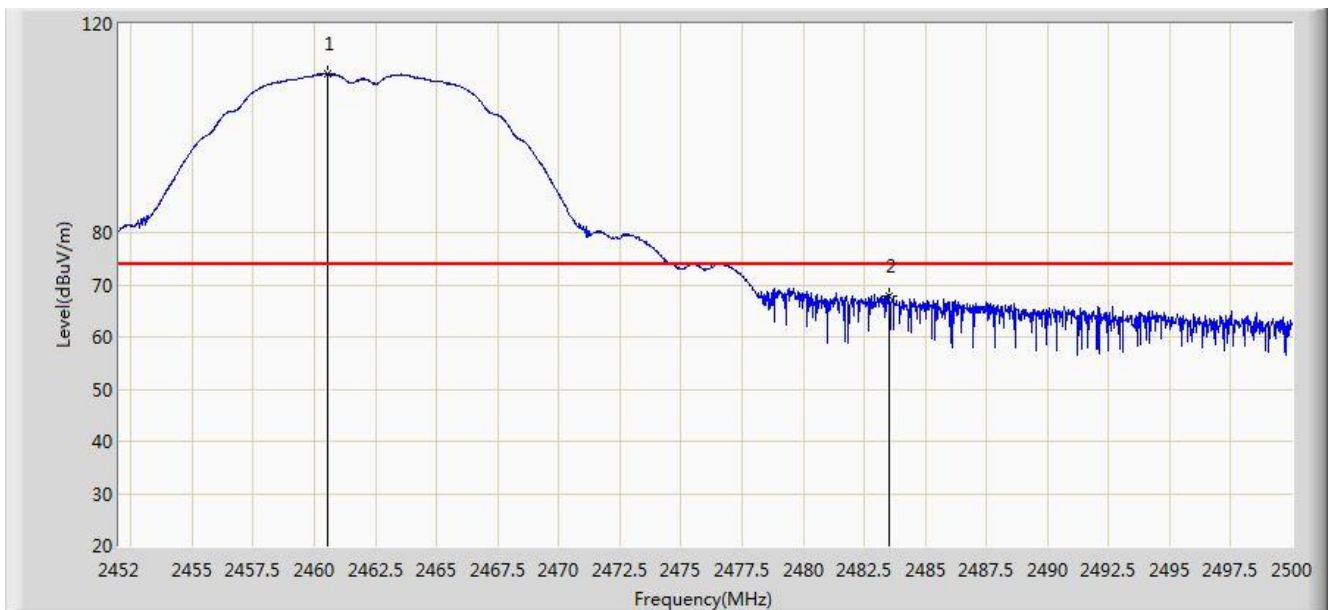

No	Flag	Mark	Frequency (MHz)	Measure Level (dBuV/m)	Reading Level (dBuV)	Over Limit (dB)	Limit (dBuV/m)	Factor (dB)	Type
1		*	2460.568	110.331	79.198	N/A	N/A	31.133	PK
2			2483.500	67.735	36.542	-6.265	74.000	31.194	PK

Note: Measure Level (dB $\mu$ V/m) = Reading Level (dB $\mu$ V) + Factor (dB)

Factor (dB) = Cable Loss (dB) + Antenna Factor (dB/m)

Site: AC1	Time: 2016/07/11 - 19:49
Limit: FCC_Part15.209_RE(3m)	Engineer: Vince Yu
Probe: BBHA9120D_1-18GHz	Polarity: Vertical
EUT: Wireless VOIP Router	Power: AC 120V/60Hz
Test Mode: Transmit by 802.11b at Channel 2462MHz Ant 1	



No	Flag	Mark	Frequency (MHz)	Measure Level (dBuV/m)	Reading Level (dBuV)	Over Limit (dB)	Limit (dBuV/m)	Factor (dB)	Type
1		*	2461.168	105.415	74.281	N/A	N/A	31.134	AV
2			2483.500	52.068	20.875	-1.932	54.000	31.194	AV

Note: Measure Level (dB $\mu$ V/m) = Reading Level (dB $\mu$ V) + Factor (dB)

Factor (dB) = Cable Loss (dB) + Antenna Factor (dB/m)



Site: AC1	Time: 2016/07/11 - 20:00
Limit: FCC_Part15.209_RE(3m)	Engineer: Vince Yu
Probe: BBHA9120D_1-18GHz	Polarity: Horizontal
EUT: Wireless VOIP Router	Power: AC 120V/60Hz
Test Mode: Transmit by 802.11g at Channel 2412MHz Ant 1	

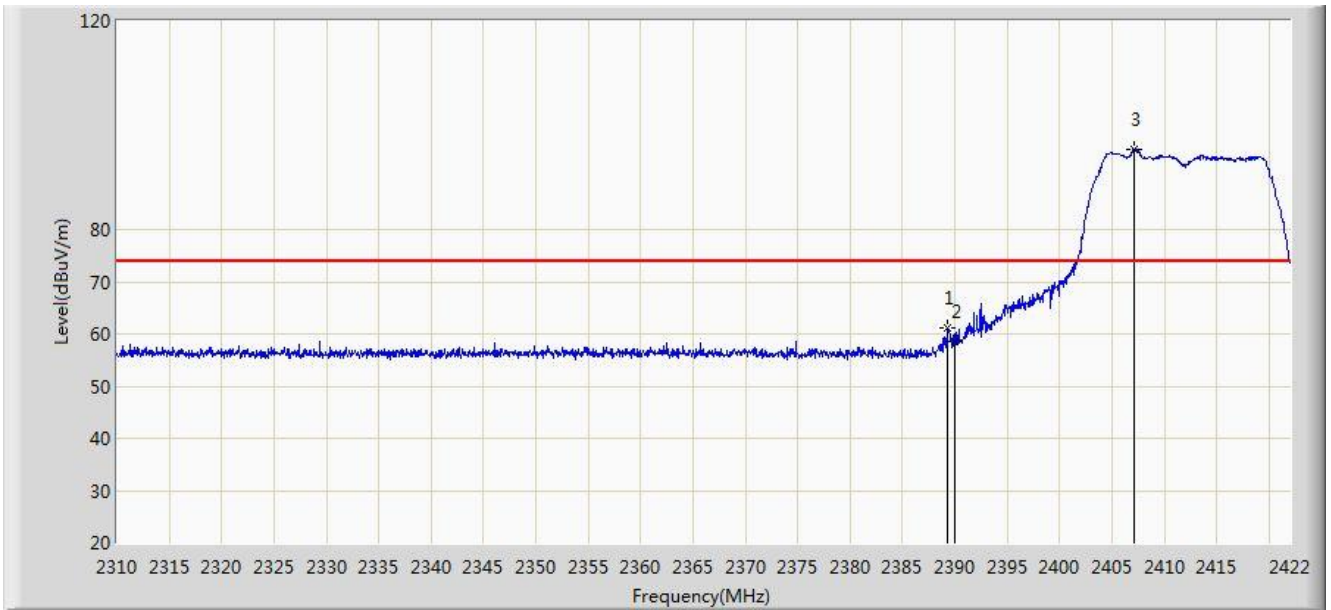

No	Flag	Mark	Frequency (MHz)	Measure Level (dBuV/m)	Reading Level (dBuV)	Over Limit (dB)	Limit (dBuV/m)	Factor (dB)	Type
1			2389.352	61.058	29.854	-12.942	74.000	31.203	PK
2			2390.000	58.678	27.475	-15.322	74.000	31.203	PK
3		*	2407.104	95.333	64.156	N/A	N/A	31.177	PK

Note: Measure Level (dB $\mu$ V/m) = Reading Level (dB $\mu$ V) + Factor (dB)

Factor (dB) = Cable Loss (dB) + Antenna Factor (dB/m)

Site: AC1	Time: 2016/07/11 - 20:01
Limit: FCC_Part15.209_RE(3m)	Engineer: Vince Yu
Probe: BBHA9120D_1-18GHz	Polarity: Horizontal
EUT: Wireless VOIP Router	Power: AC 120V/60Hz
Test Mode: Transmit by 802.11g at Channel 2412MHz Ant 1	

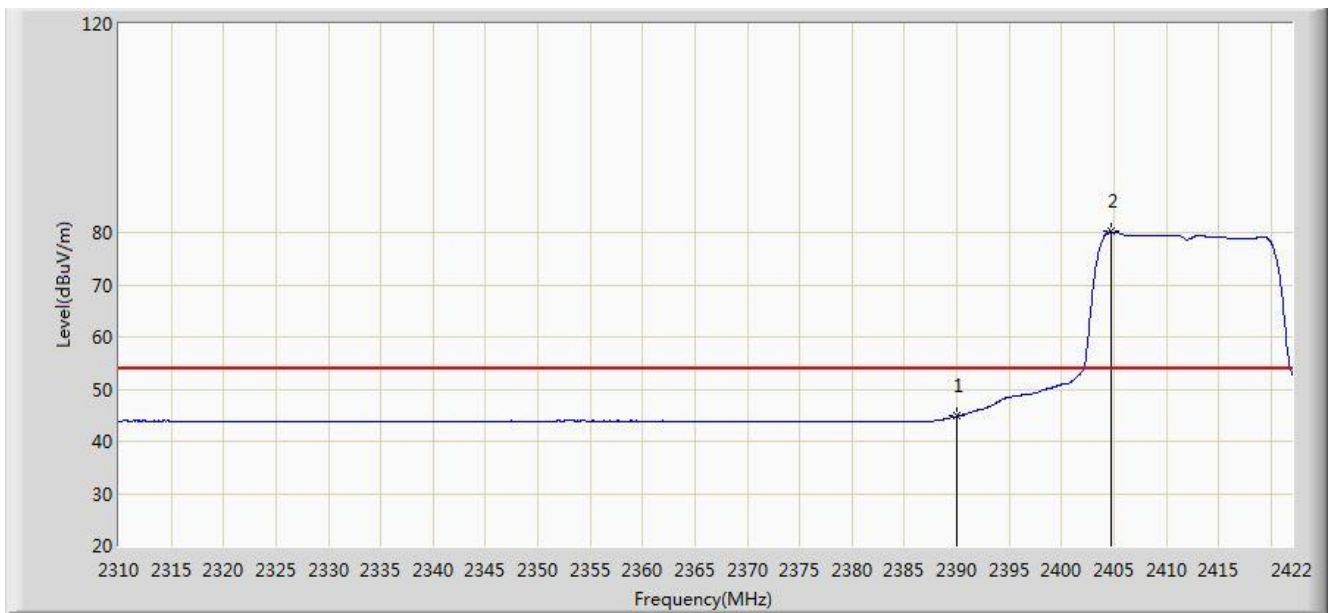

No	Flag	Mark	Frequency (MHz)	Measure Level (dBuV/m)	Reading Level (dBuV)	Over Limit (dB)	Limit (dBuV/m)	Factor (dB)	Type
1			2390.000	44.820	13.617	-9.180	54.000	31.203	AV
2		*	2404.696	80.153	48.973	N/A	N/A	31.180	AV

Note: Measure Level (dBuV/m) = Reading Level (dBuV) + Factor (dB)

Factor (dB) = Cable Loss (dB) + Antenna Factor (dB/m)

Site: AC1	Time: 2016/07/11 - 19:56
Limit: FCC_Part15.209_RE(3m)	Engineer: Vince Yu
Probe: BBHA9120D_1-18GHz	Polarity: Vertical
EUT: Wireless VOIP Router	Power: AC 120V/60Hz
Test Mode: Transmit by 802.11g at Channel 2412MHz Ant 1	



No	Flag	Mark	Frequency (MHz)	Measure Level (dBuV/m)	Reading Level (dBuV)	Over Limit (dB)	Limit (dBuV/m)	Factor (dB)	Type
1			2389.520	72.169	40.965	-1.831	74.000	31.204	PK
2			2390.000	69.215	38.012	-4.785	74.000	31.203	PK
3		*	2407.328	109.792	78.616	N/A	N/A	31.176	PK

Note: Measure Level (dB $\mu$ V/m) = Reading Level (dB $\mu$ V) + Factor (dB)

Factor (dB) = Cable Loss (dB) + Antenna Factor (dB/m)

Site: AC1	Time: 2016/07/11 - 20:00
Limit: FCC_Part15.209_RE(3m)	Engineer: Vince Yu
Probe: BBHA9120D_1-18GHz	Polarity: Vertical
EUT: Wireless VOIP Router	Power: AC 120V/60Hz
Test Mode: Transmit by 802.11g at Channel 2412MHz Ant 1	

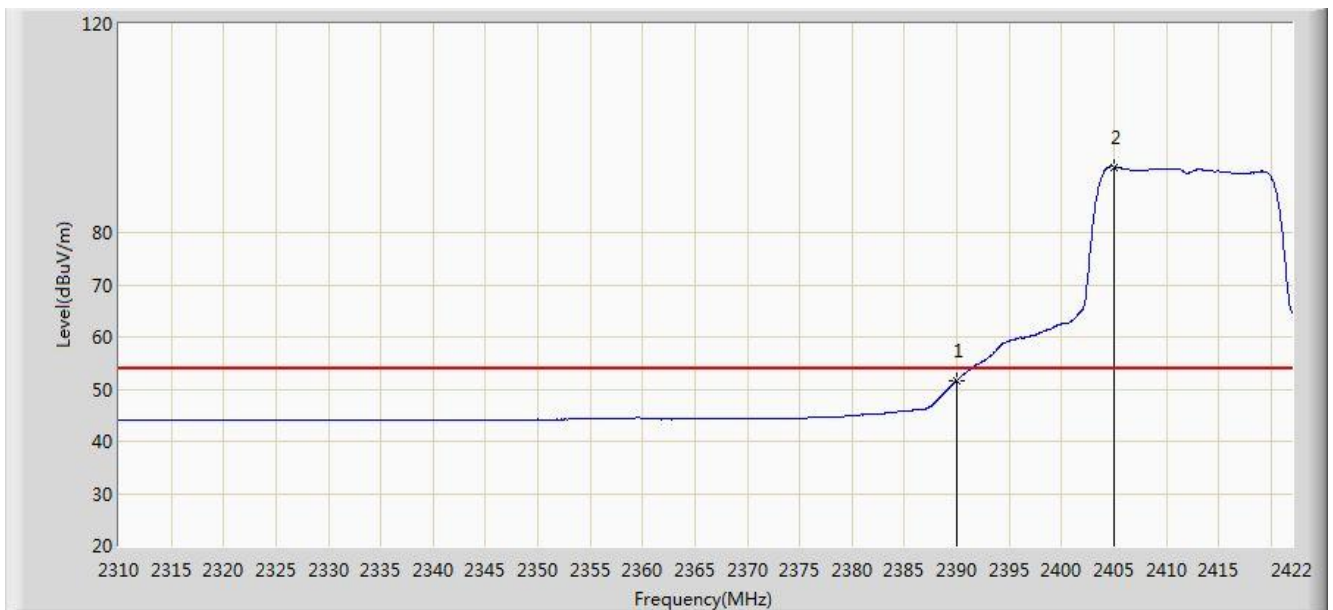

No	Flag	Mark	Frequency (MHz)	Measure Level (dBuV/m)	Reading Level (dBuV)	Over Limit (dB)	Limit (dBuV/m)	Factor (dB)	Type
1			2390.000	51.674	20.471	-2.326	54.000	31.203	AV
2		*	2405.032	92.606	61.426	N/A	N/A	31.180	AV

Note: Measure Level (dB $\mu$ V/m) = Reading Level (dB $\mu$ V) + Factor (dB)

Factor (dB) = Cable Loss (dB) + Antenna Factor (dB/m)

Site: AC1	Time: 2016/07/11 - 20:06
Limit: FCC_Part15.209_RE(3m)	Engineer: Vince Yu
Probe: BBHA9120D_1-18GHz	Polarity: Horizontal
EUT: Wireless VOIP Router	Power: AC 120V/60Hz
Test Mode: Transmit by 802.11g at Channel 2462MHz Ant 1	

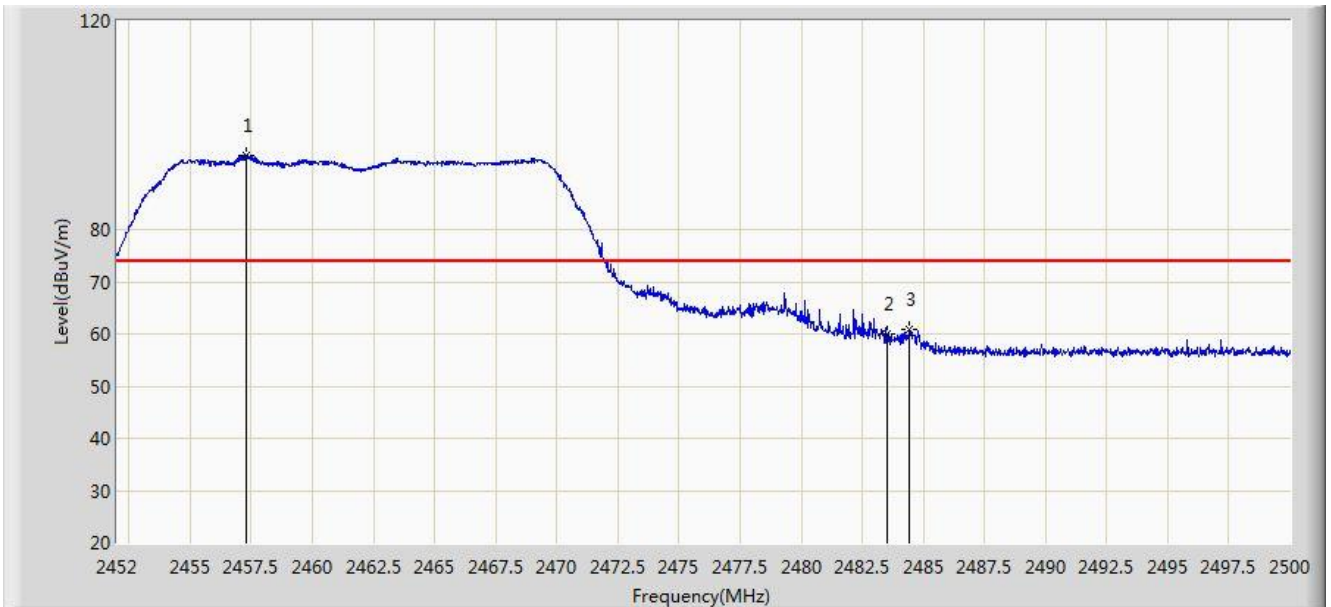

No	Flag	Mark	Frequency (MHz)	Measure Level (dBuV/m)	Reading Level (dBuV)	Over Limit (dB)	Limit (dBuV/m)	Factor (dB)	Type
1		*	2457.304	94.182	63.055	N/A	N/A	31.127	PK
2			2483.500	59.859	28.666	-14.141	74.000	31.194	PK
3			2484.448	60.843	29.647	-13.157	74.000	31.195	PK

Note: Measure Level (dB $\mu$ V/m) = Reading Level (dB $\mu$ V) + Factor (dB)

Factor (dB) = Cable Loss (dB) + Antenna Factor (dB/m)

Site: AC1	Time: 2016/07/11 - 20:07
Limit: FCC_Part15.209_RE(3m)	Engineer: Vince Yu
Probe: BBHA9120D_1-18GHz	Polarity: Horizontal
EUT: Wireless VOIP Router	Power: AC 120V/60Hz
Test Mode: Transmit by 802.11g at Channel 2462MHz Ant 1	

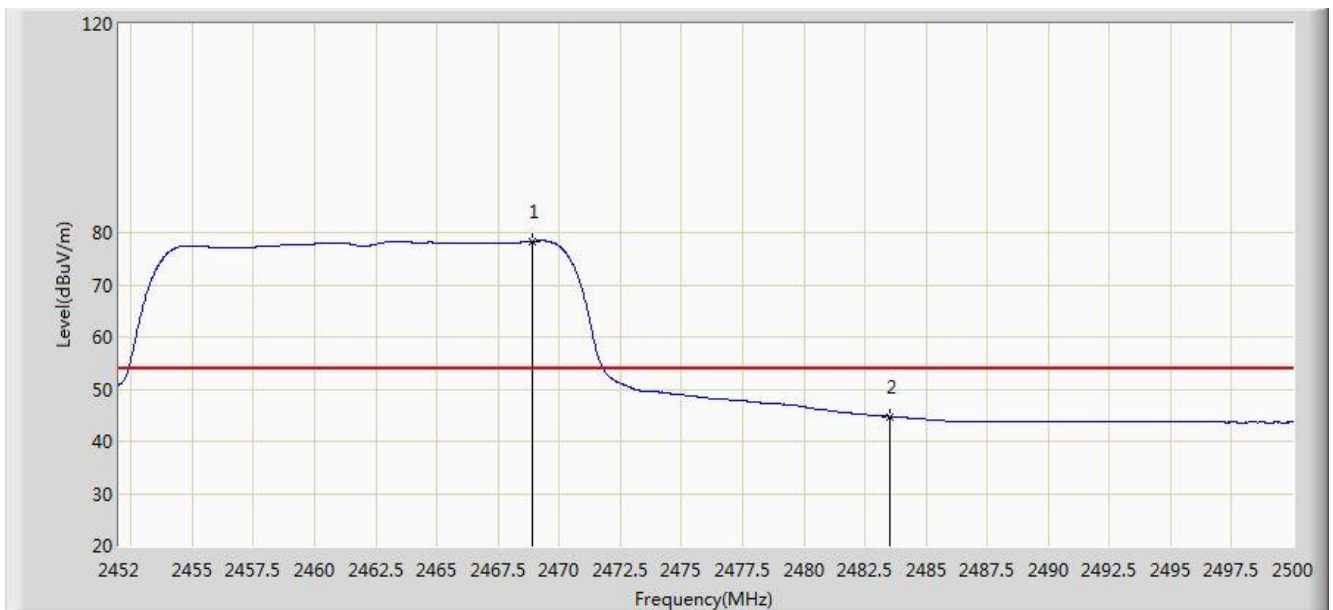

No	Flag	Mark	Frequency (MHz)	Measure Level (dBuV/m)	Reading Level (dBuV)	Over Limit (dB)	Limit (dBuV/m)	Factor (dB)	Type
1		*	2468.920	78.342	47.189	N/A	N/A	31.153	AV
2			2483.500	44.768	13.575	-9.232	54.000	31.194	AV

Note: Measure Level (dBuV/m) = Reading Level (dBuV) + Factor (dB)

Factor (dB) = Cable Loss (dB) + Antenna Factor (dB/m)

Site: AC1	Time: 2016/07/11 - 20:05
Limit: FCC_Part15.209_RE(3m)	Engineer: Vince Yu
Probe: BBHA9120D_1-18GHz	Polarity: Vertical
EUT: Wireless VOIP Router	Power: AC 120V/60Hz
Test Mode: Transmit by 802.11g at Channel 2462MHz Ant 1	

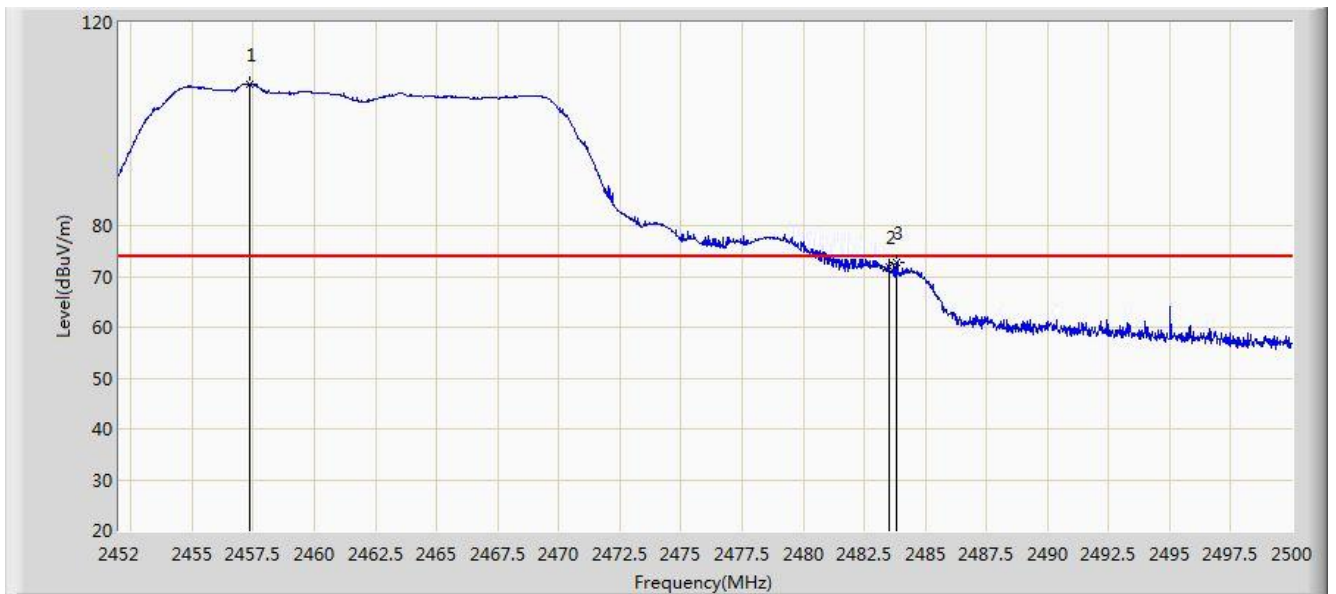

No	Flag	Mark	Frequency (MHz)	Measure Level (dBuV/m)	Reading Level (dBuV)	Over Limit (dB)	Limit (dBuV/m)	Factor (dB)	Type
1		*	2457.352	107.915	76.788	N/A	N/A	31.127	PK
2			2483.500	71.827	40.634	-2.173	74.000	31.194	PK
3			2483.848	72.771	41.577	-1.229	74.000	31.194	PK

Note: Measure Level (dB $\mu$ V/m) = Reading Level (dB $\mu$ V) + Factor (dB)

Factor (dB) = Cable Loss (dB) + Antenna Factor (dB/m)

Site: AC1	Time: 2016/07/11 - 20:05
Limit: FCC_Part15.209_RE(3m)	Engineer: Vince Yu
Probe: BBHA9120D_1-18GHz	Polarity: Vertical
EUT: Wireless VOIP Router	Power: AC 120V/60Hz
Test Mode: Transmit by 802.11g at Channel 2462MHz Ant 1	

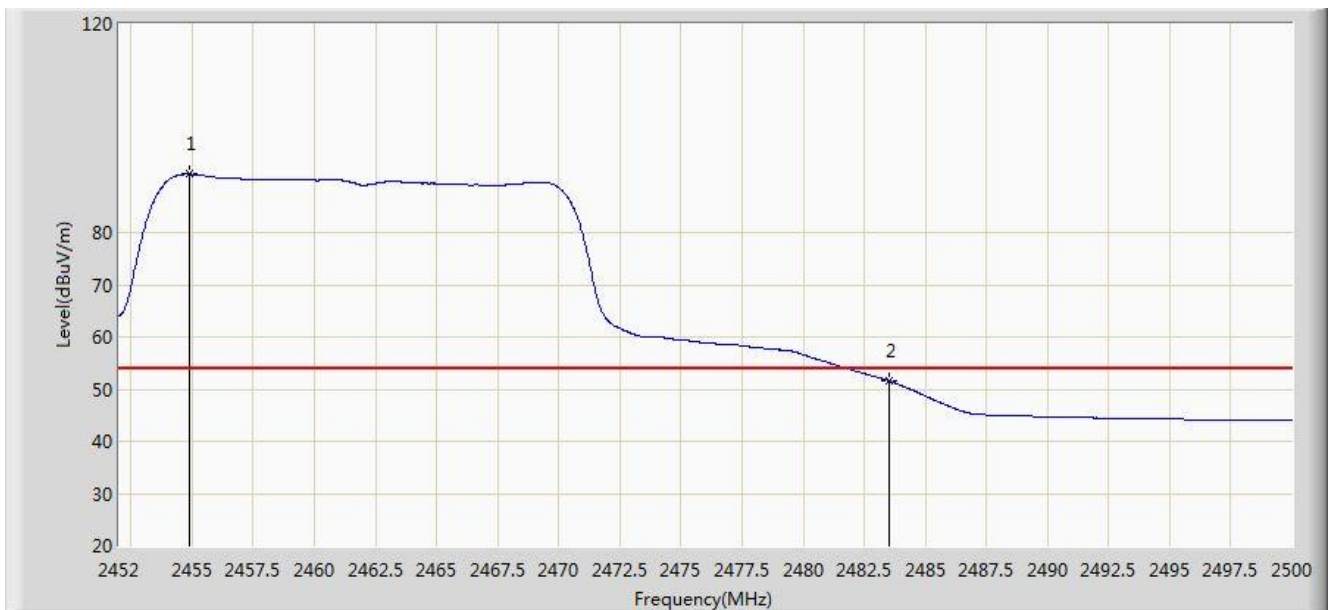

No	Flag	Mark	Frequency (MHz)	Measure Level (dBuV/m)	Reading Level (dBuV)	Over Limit (dB)	Limit (dBuV/m)	Factor (dB)	Type
1		*	2454.880	91.160	60.037	N/A	N/A	31.123	AV
2			2483.500	51.611	20.418	-2.389	54.000	31.194	AV

Note: Measure Level (dBuV/m) = Reading Level (dBuV) + Factor (dB)

Factor (dB) = Cable Loss (dB) + Antenna Factor (dB/m)



Site: AC1	Time: 2016/07/11 - 20:19
Limit: FCC_Part15.209_RE(3m)	Engineer: Vince Yu
Probe: BBHA9120D_1-18GHz	Polarity: Horizontal
EUT: Wireless VOIP Router	Power: AC 120V/60Hz
Test Mode: Transmit by 802.11n-HT20 at Channel 2412MHz Ant 0 + 1	

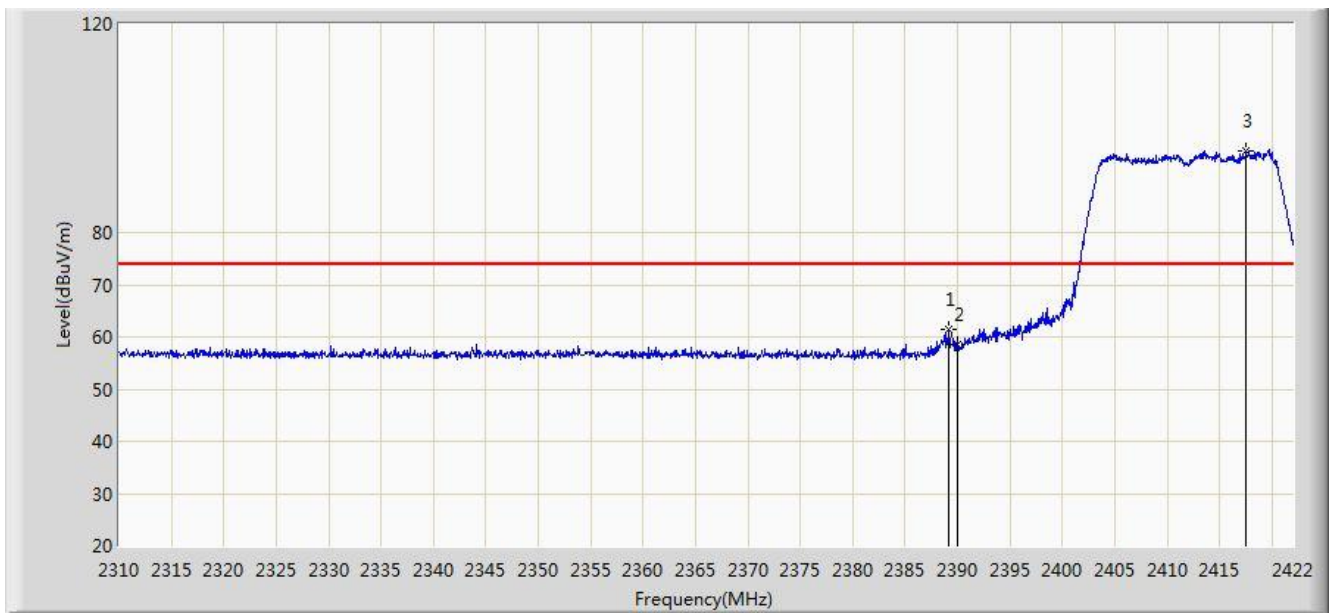

No	Flag	Mark	Frequency (MHz)	Measure Level (dBuV/m)	Reading Level (dBuV)	Over Limit (dB)	Limit (dBuV/m)	Factor (dB)	Type
1			2389.184	61.306	30.102	-12.694	74.000	31.204	PK
2			2390.000	58.540	27.337	-15.460	74.000	31.203	PK
3		*	2417.576	95.716	64.556	N/A	N/A	31.160	PK

Note: Measure Level (dB $\mu$ V/m) = Reading Level (dB $\mu$ V) + Factor (dB)

Factor (dB) = Cable Loss (dB) + Antenna Factor (dB/m)

Site: AC1	Time: 2016/07/11 - 20:20
Limit: FCC_Part15.209_RE(3m)	Engineer: Vince Yu
Probe: BBHA9120D_1-18GHz	Polarity: Horizontal
EUT: Wireless VOIP Router	Power: AC 120V/60Hz
Test Mode: Transmit by 802.11n-HT20 at Channel 2412MHz Ant 0 + 1	

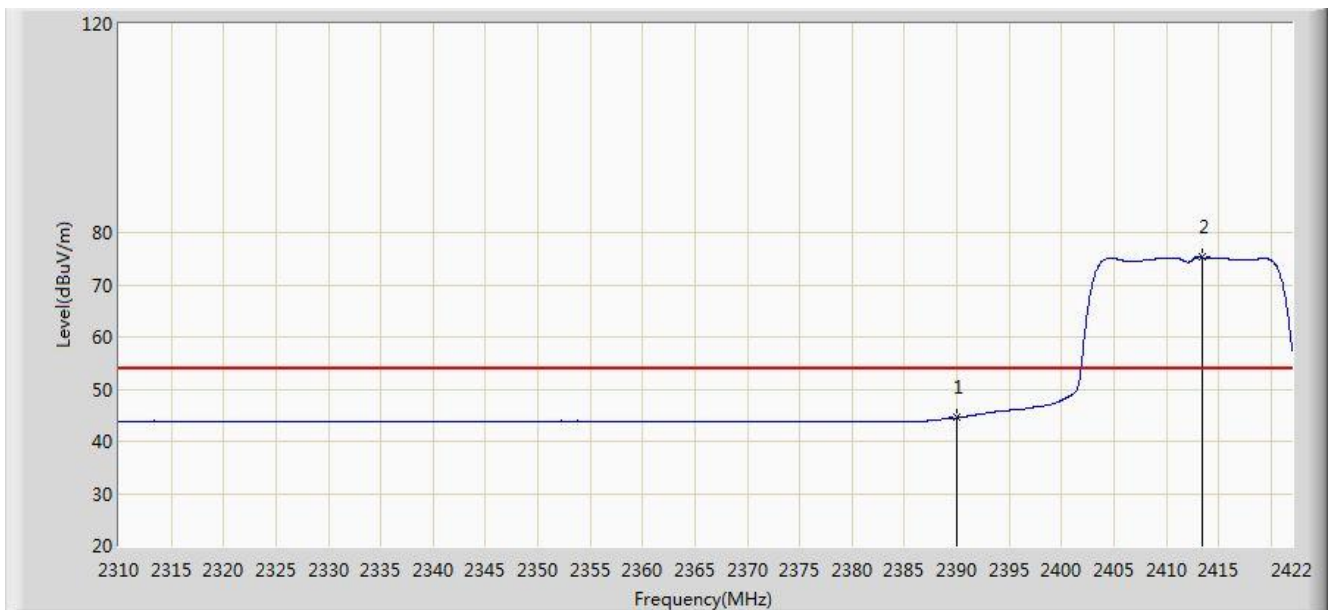

No	Flag	Mark	Frequency (MHz)	Measure Level (dBuV/m)	Reading Level (dBuV)	Over Limit (dB)	Limit (dBuV/m)	Factor (dB)	Type
1			2390.000	44.494	13.291	-9.506	54.000	31.203	AV
2		*	2413.432	75.223	44.056	N/A	N/A	31.168	AV

Note: Measure Level (dB $\mu$ V/m) = Reading Level (dB $\mu$ V) + Factor (dB)

Factor (dB) = Cable Loss (dB) + Antenna Factor (dB/m)

Site: AC1	Time: 2016/07/11 - 20:17
Limit: FCC_Part15.209_RE(3m)	Engineer: Vince Yu
Probe: BBHA9120D_1-18GHz	Polarity: Vertical
EUT: Wireless VOIP Router	Power: AC 120V/60Hz
Test Mode: Transmit by 802.11n-HT20 at Channel 2412MHz Ant 0 + 1	

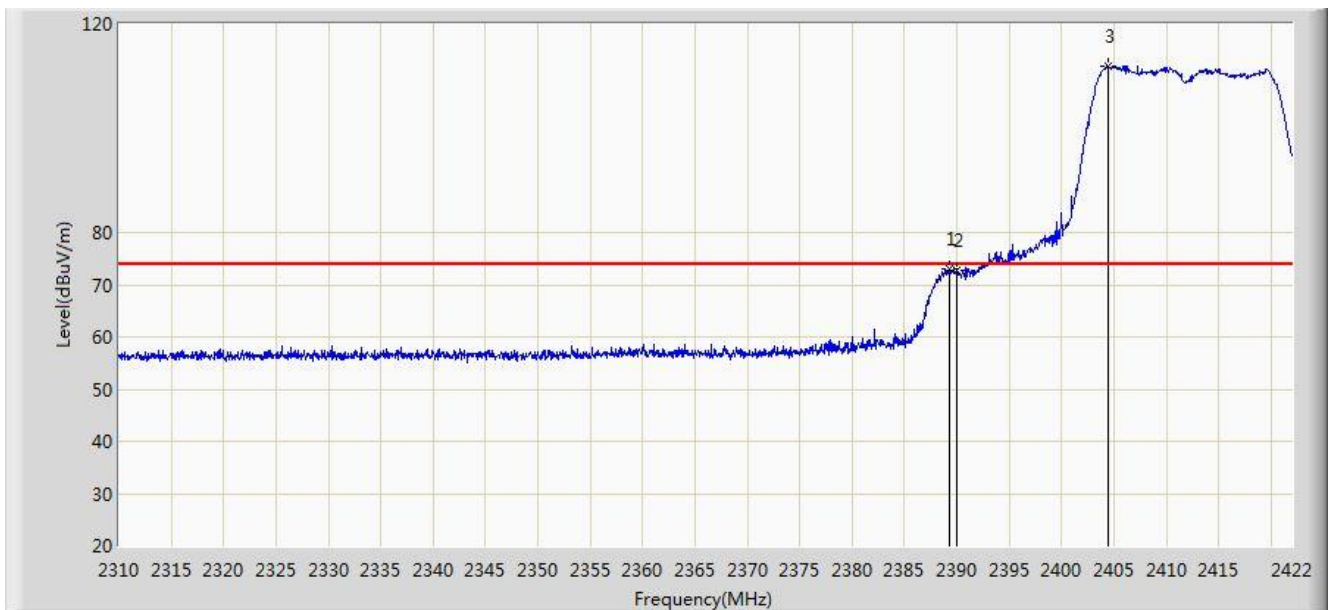

No	Flag	Mark	Frequency (MHz)	Measure Level (dBuV/m)	Reading Level (dBuV)	Over Limit (dB)	Limit (dBuV/m)	Factor (dB)	Type
1			2389.296	72.981	41.777	-1.019	74.000	31.204	PK
2			2390.000	72.835	41.632	-1.165	74.000	31.203	PK
3		*	2404.416	111.789	80.608	N/A	N/A	31.181	PK

Note: Measure Level (dB $\mu$ V/m) = Reading Level (dB $\mu$ V) + Factor (dB)

Factor (dB) = Cable Loss (dB) + Antenna Factor (dB/m)

Site: AC1	Time: 2016/07/11 - 20:18
Limit: FCC_Part15.209_RE(3m)	Engineer: Vince Yu
Probe: BBHA9120D_1-18GHz	Polarity: Vertical
EUT: Wireless VOIP Router	Power: AC 120V/60Hz
Test Mode: Transmit by 802.11n-HT20 at Channel 2412MHz Ant 0 + 1	

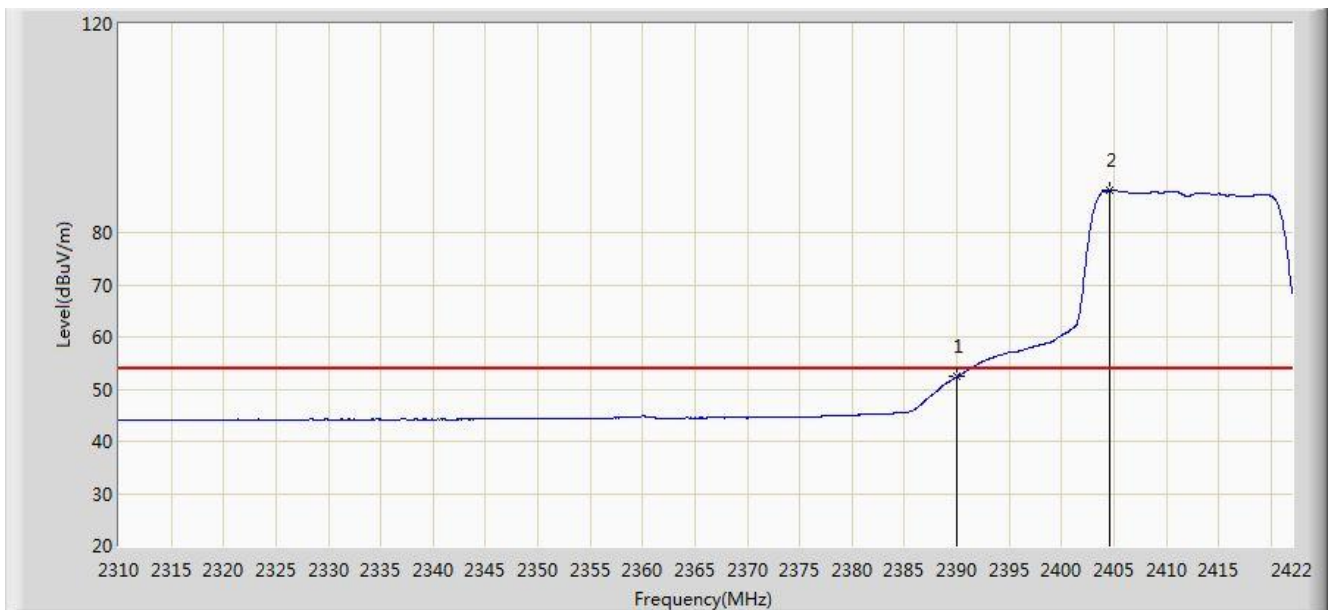

No	Flag	Mark	Frequency (MHz)	Measure Level (dBuV/m)	Reading Level (dBuV)	Over Limit (dB)	Limit (dBuV/m)	Factor (dB)	Type
1			2390.000	52.346	21.143	-1.654	54.000	31.203	AV
2		*	2404.640	88.168	56.988	N/A	N/A	31.180	AV

Note: Measure Level (dBuV/m) = Reading Level (dBuV) + Factor (dB)

Factor (dB) = Cable Loss (dB) + Antenna Factor (dB/m)

Site: AC1	Time: 2016/07/12 - 09:40
Limit: FCC_Part15.209_RE(3m)	Engineer: Vince Yu
Probe: BBHA9120D_1-18GHz	Polarity: Horizontal
EUT: Wireless VOIP Router	Power: AC 120V/60Hz
Test Mode: Transmit by 802.11n-HT20 at Channel 2462MHz Ant 0 + 1	

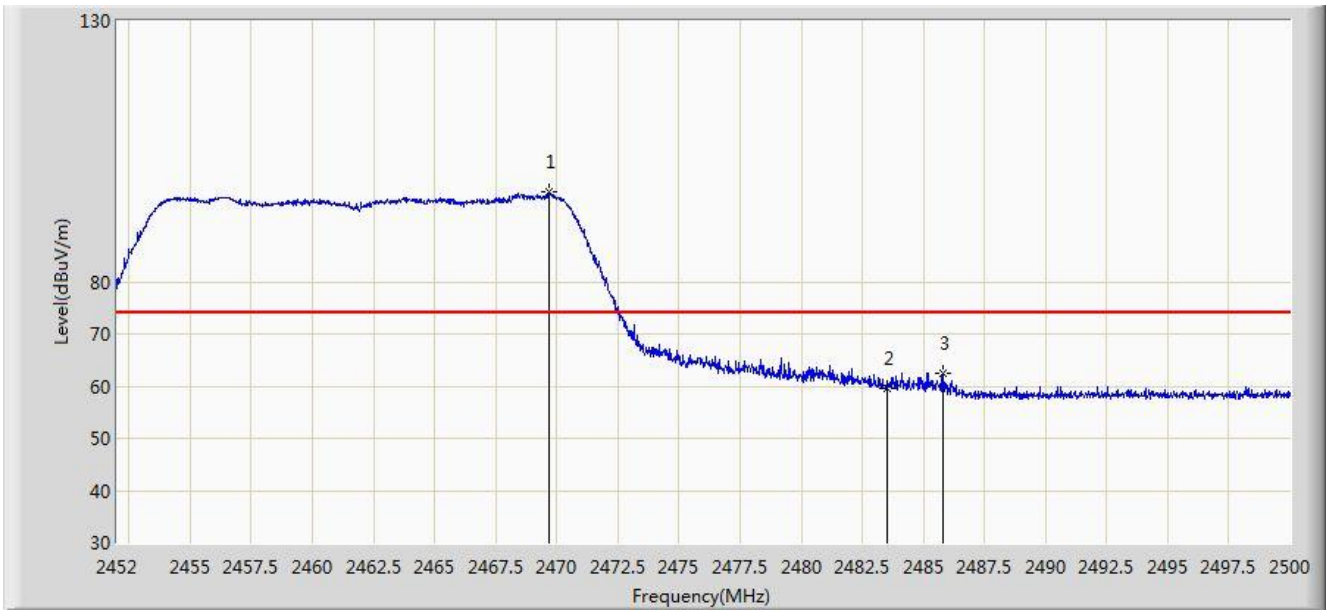

No	Flag	Mark	Frequency (MHz)	Measure Level (dBuV/m)	Reading Level (dBuV)	Over Limit (dB)	Limit (dBuV/m)	Factor (dB)	Type
1		*	2469.688	97.304	66.149	N/A	N/A	31.156	PK
2			2483.500	59.488	28.295	-14.512	74.000	31.194	PK
3			2485.792	62.410	31.211	-11.590	74.000	31.200	PK

Note: Measure Level (dB $\mu$ V/m) = Reading Level (dB $\mu$ V) + Factor (dB)

Factor (dB) = Cable Loss (dB) + Antenna Factor (dB/m)

Site: AC1	Time: 2016/07/12 - 09:44
Limit: FCC_Part15.209_RE(3m)	Engineer: Vince Yu
Probe: BBHA9120D_1-18GHz	Polarity: Horizontal
EUT: Wireless VOIP Router	Power: AC 120V/60Hz
Test Mode: Transmit by 802.11n-HT20 at Channel 2462MHz Ant 0 + 1	

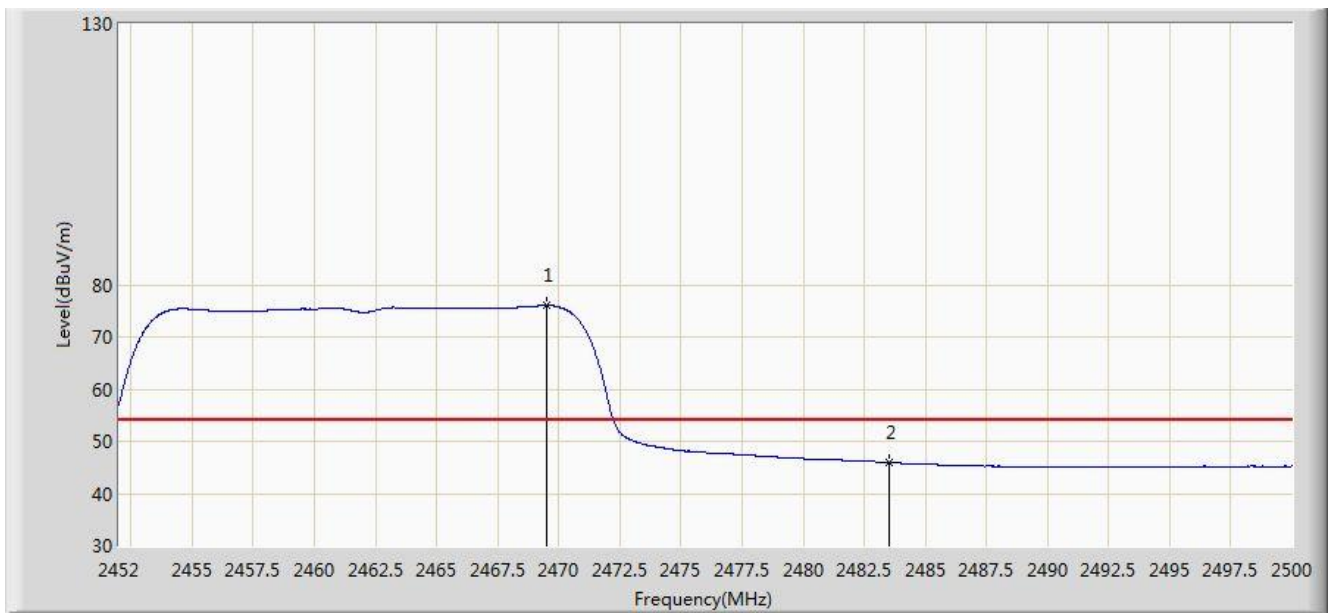

No	Flag	Mark	Frequency (MHz)	Measure Level (dBuV/m)	Reading Level (dBuV)	Over Limit (dB)	Limit (dBuV/m)	Factor (dB)	Type
1		*	2469.520	76.035	44.880	N/A	N/A	31.155	AV
2			2483.500	45.955	14.762	-8.045	54.000	31.194	AV

Note: Measure Level (dB $\mu$ V/m) = Reading Level (dB $\mu$ V) + Factor (dB)

Factor (dB) = Cable Loss (dB) + Antenna Factor (dB/m)

Site: AC1	Time: 2016/07/12 - 09:38
Limit: FCC_Part15.209_RE(3m)	Engineer: Vince Yu
Probe: BBHA9120D_1-18GHz	Polarity: Vertical
EUT: Wireless VOIP Router	Power: AC 120V/60Hz
Test Mode: Transmit by 802.11n-HT20 at Channel 2462MHz Ant 0 + 1	



No	Flag	Mark	Frequency (MHz)	Measure Level (dBuV/m)	Reading Level (dBuV)	Over Limit (dB)	Limit (dBuV/m)	Factor (dB)	Type
1		*	2469.832	110.951	79.795	N/A	N/A	31.156	PK
2			2483.500	70.312	39.119	-3.688	74.000	31.194	PK
3			2483.632	72.645	41.451	-1.355	74.000	31.194	PK

Note: Measure Level (dB $\mu$ V/m) = Reading Level (dB $\mu$ V) + Factor (dB)

Factor (dB) = Cable Loss (dB) + Antenna Factor (dB/m)

Site: AC1	Time: 2016/07/12 - 09:37
Limit: FCC_Part15.209_RE(3m)	Engineer: Vince Yu
Probe: BBHA9120D_1-18GHz	Polarity: Vertical
EUT: Wireless VOIP Router	Power: AC 120V/60Hz
Test Mode: Transmit by 802.11n-HT20 at Channel 2462MHz Ant 0 + 1	

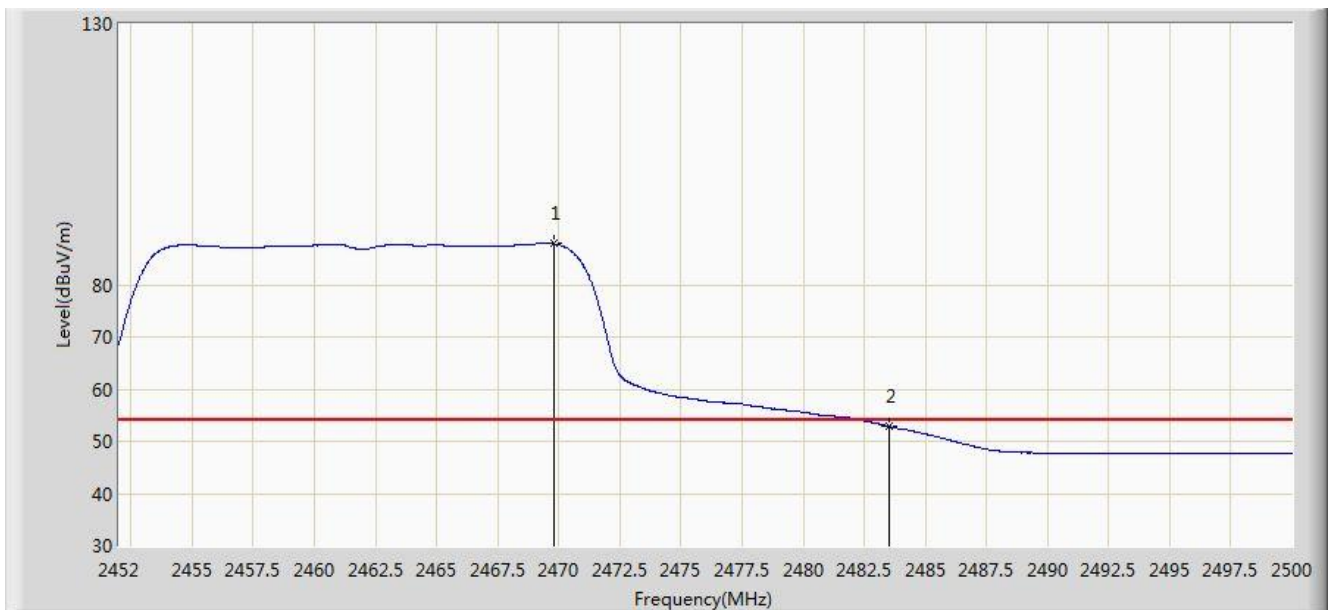

No	Flag	Mark	Frequency (MHz)	Measure Level (dBuV/m)	Reading Level (dBuV)	Over Limit (dB)	Limit (dBuV/m)	Factor (dB)	Type
1		*	2469.808	87.830	56.674	N/A	N/A	31.156	AV
2			2483.500	52.870	21.677	-1.130	54.000	31.194	AV

Note: Measure Level (dB $\mu$ V/m) = Reading Level (dB $\mu$ V) + Factor (dB)

Factor (dB) = Cable Loss (dB) + Antenna Factor (dB/m)



Site: AC1	Time: 2016/07/12 - 18:46
Limit: FCC_Part15.209_RE(3m)	Engineer: Vince Yu
Probe: BBHA9120D_1-18GHz	Polarity: Horizontal
EUT: Wireless VOIP Router	Power: AC 120V/60Hz
Test Mode: Transmit by 802.11n-HT40 at Channel 2422MHz Ant 0 + 1	

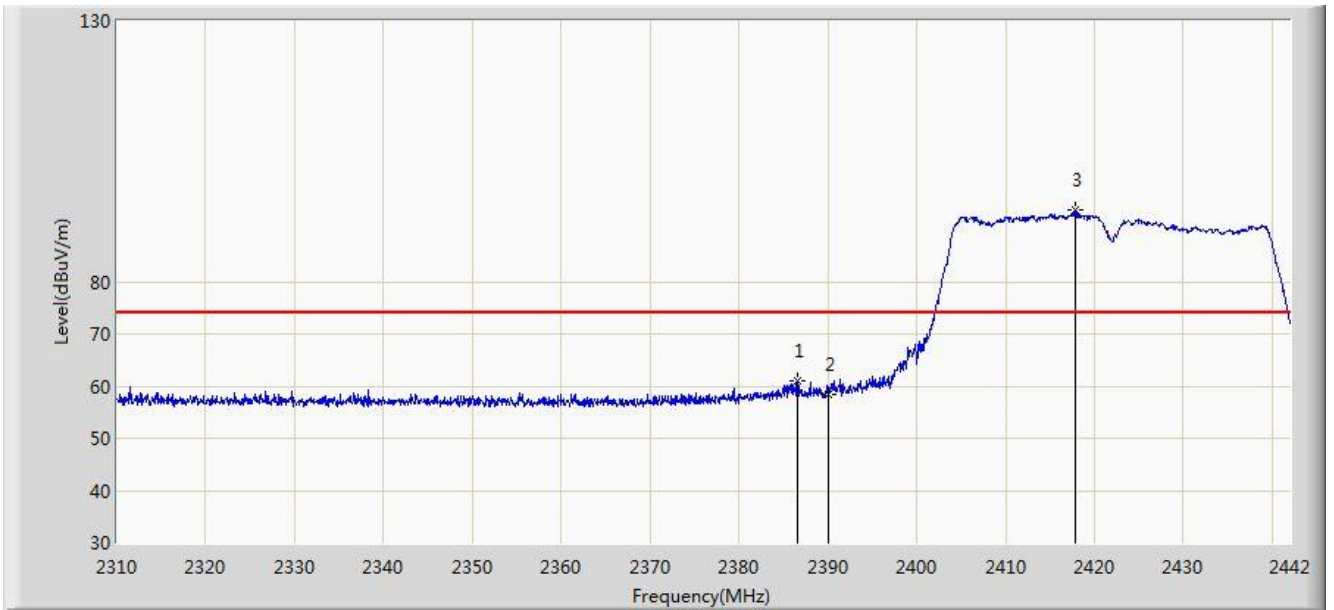

No	Flag	Mark	Frequency (MHz)	Measure Level (dBuV/m)	Reading Level (dBuV)	Over Limit (dB)	Limit (dBuV/m)	Factor (dB)	Type
1			2386.560	60.961	29.752	-13.039	74.000	31.209	PK
2			2390.000	58.367	27.164	-15.633	74.000	31.203	PK
3		*	2417.844	93.735	62.576	N/A	N/A	31.159	PK

Note: Measure Level (dB $\mu$ V/m) = Reading Level (dB $\mu$ V) + Factor (dB)

Factor (dB) = Cable Loss (dB) + Antenna Factor (dB/m)

Site: AC1	Time: 2016/07/12 - 18:49
Limit: FCC_Part15.209_RE(3m)	Engineer: Vince Yu
Probe: BBHA9120D_1-18GHz	Polarity: Horizontal
EUT: Wireless VOIP Router	Power: AC 120V/60Hz
Test Mode: Transmit by 802.11n-HT40 at Channel 2422MHz Ant 0 + 1	

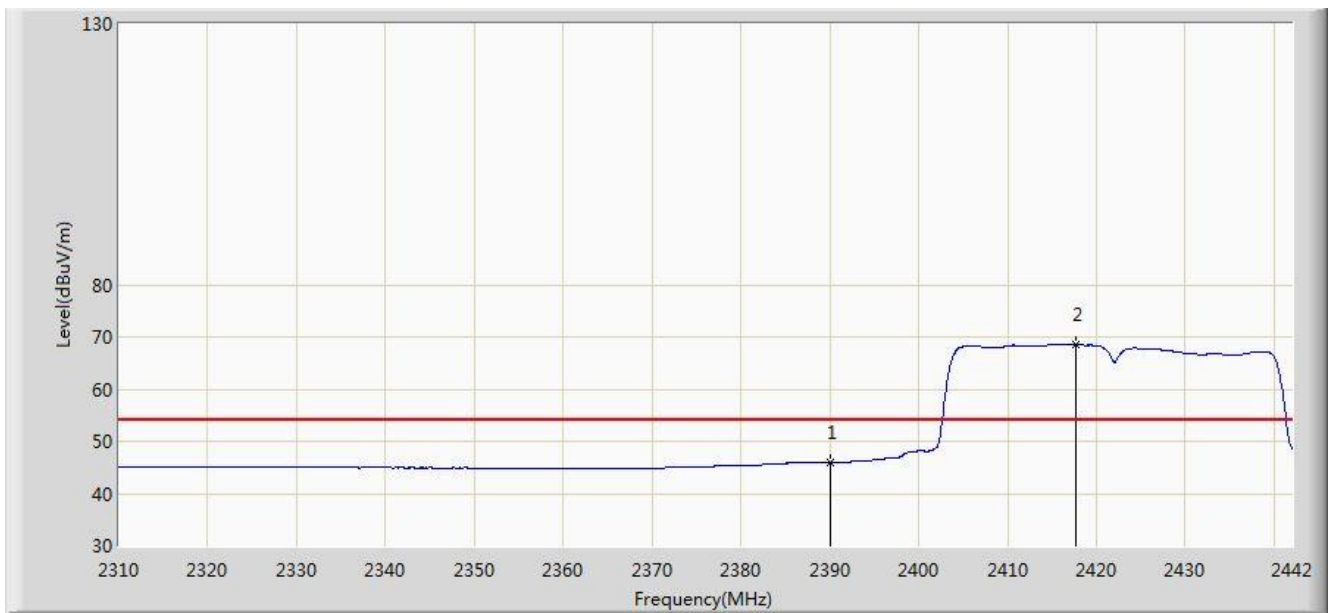

No	Flag	Mark	Frequency (MHz)	Measure Level (dBuV/m)	Reading Level (dBuV)	Over Limit (dB)	Limit (dBuV/m)	Factor (dB)	Type
1			2390.000	45.921	14.718	-8.079	54.000	31.203	AV
2		*	2417.712	68.446	37.286	N/A	N/A	31.159	AV

Note: Measure Level (dB $\mu$ V/m) = Reading Level (dB $\mu$ V) + Factor (dB)

Factor (dB) = Cable Loss (dB) + Antenna Factor (dB/m)

Site: AC1	Time: 2016/07/12 - 10:05
Limit: FCC_Part15.209_RE(3m)	Engineer: Vince Yu
Probe: BBHA9120D_1-18GHz	Polarity: Vertical
EUT: Wireless VOIP Router	Power: AC 120V/60Hz
Test Mode: Transmit by 802.11n-HT40 at Channel 2422MHz Ant 0 + 1	

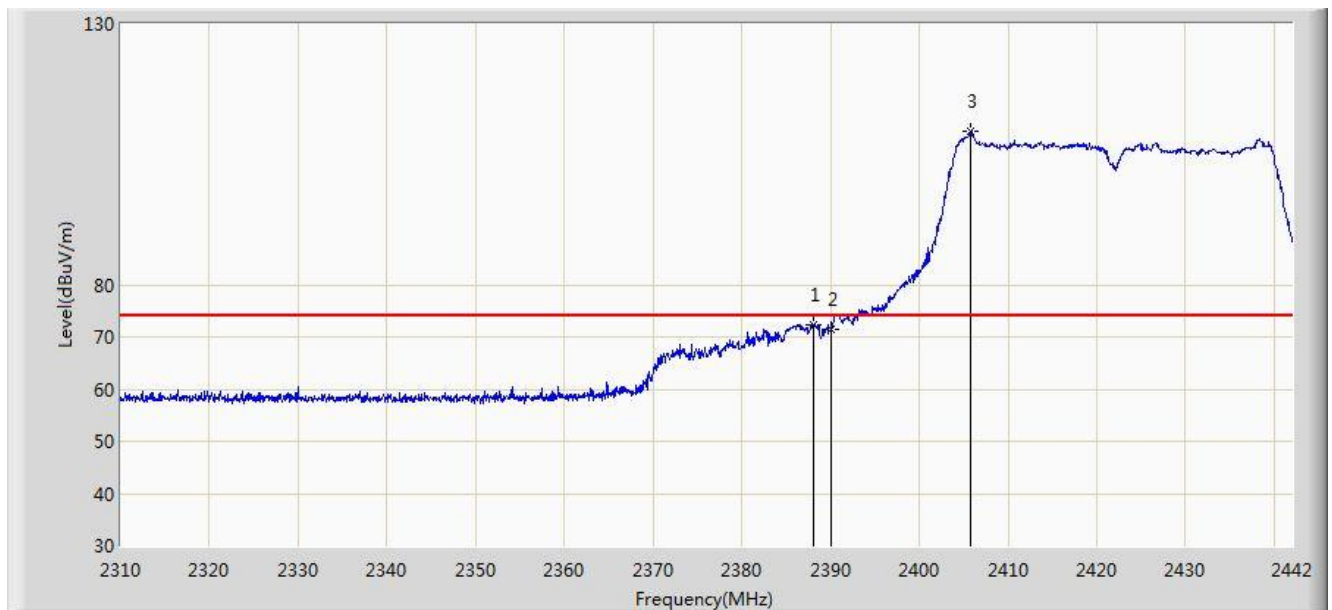

No	Flag	Mark	Frequency (MHz)	Measure Level (dBuV/m)	Reading Level (dBuV)	Over Limit (dB)	Limit (dBuV/m)	Factor (dB)	Type
1			2388.012	72.415	41.209	-1.585	74.000	31.206	PK
2			2390.000	71.471	40.268	-2.529	74.000	31.203	PK
3		*	2405.832	109.436	78.257	N/A	N/A	31.179	PK

Note: Measure Level (dB $\mu$ V/m) = Reading Level (dB $\mu$ V) + Factor (dB)

Factor (dB) = Cable Loss (dB) + Antenna Factor (dB/m)

Site: AC1	Time: 2016/07/12 - 10:06
Limit: FCC_Part15.209_RE(3m)	Engineer: Vince Yu
Probe: BBHA9120D_1-18GHz	Polarity: Vertical
EUT: Wireless VOIP Router	Power: AC 120V/60Hz
Test Mode: Transmit by 802.11n-HT40 at Channel 2422MHz Ant 0 + 1	

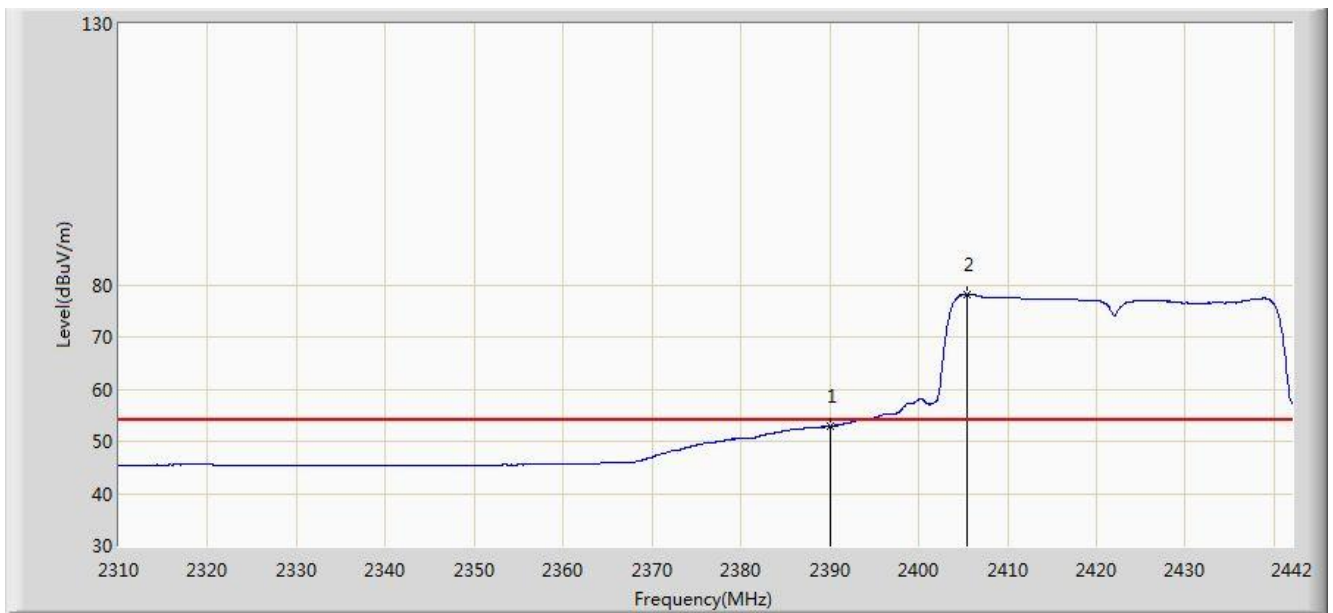

No	Flag	Mark	Frequency (MHz)	Measure Level (dBuV/m)	Reading Level (dBuV)	Over Limit (dB)	Limit (dBuV/m)	Factor (dB)	Type
1			2390.000	52.884	21.681	-1.116	54.000	31.203	AV
2		*	2405.370	78.145	46.966	N/A	N/A	31.179	AV

Note: Measure Level (dBuV/m) = Reading Level (dBuV) + Factor (dB)

Factor (dB) = Cable Loss (dB) + Antenna Factor (dB/m)

Site: AC1	Time: 2016/07/12 - 18:50
Limit: FCC_Part15.209_RE(3m)	Engineer: Vince Yu
Probe: BBHA9120D_1-18GHz	Polarity: Horizontal
EUT: Wireless VOIP Router	Power: AC 120V/60Hz
Test Mode: Transmit by 802.11n-HT40 at Channel 2452MHz Ant 0 + 1	

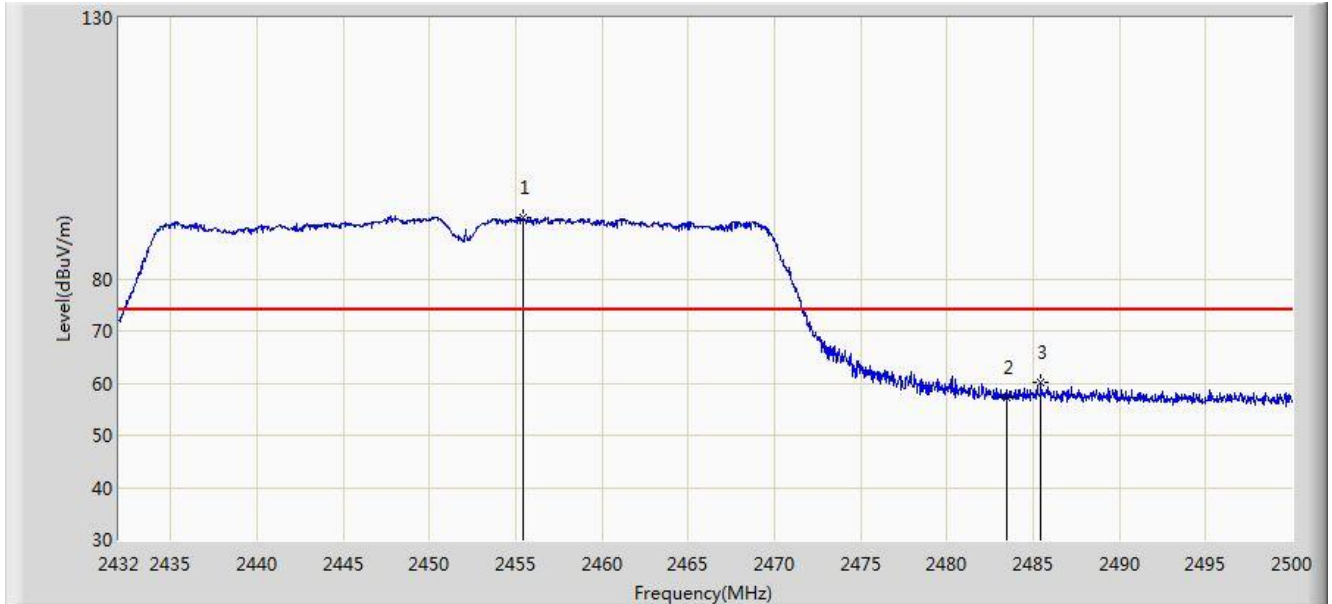

No	Flag	Mark	Frequency (MHz)	Measure Level (dBuV/m)	Reading Level (dBuV)	Over Limit (dB)	Limit (dBuV/m)	Factor (dB)	Type
1		*	2455.392	91.682	60.558	N/A	N/A	31.123	PK
2			2483.500	57.303	26.110	-16.697	74.000	31.194	PK
3			2485.448	60.044	28.846	-13.956	74.000	31.198	PK

Note: Measure Level (dBuV/m) = Reading Level (dBuV) + Factor (dB)

Factor (dB) = Cable Loss (dB) + Antenna Factor (dB/m)

Site: AC1	Time: 2016/07/12 - 18:51
Limit: FCC_Part15.209_RE(3m)	Engineer: Vince Yu
Probe: BBHA9120D_1-18GHz	Polarity: Horizontal
EUT: Wireless VOIP Router	Power: AC 120V/60Hz
Test Mode: Transmit by 802.11n-HT40 at Channel 2452MHz Ant 0 + 1	

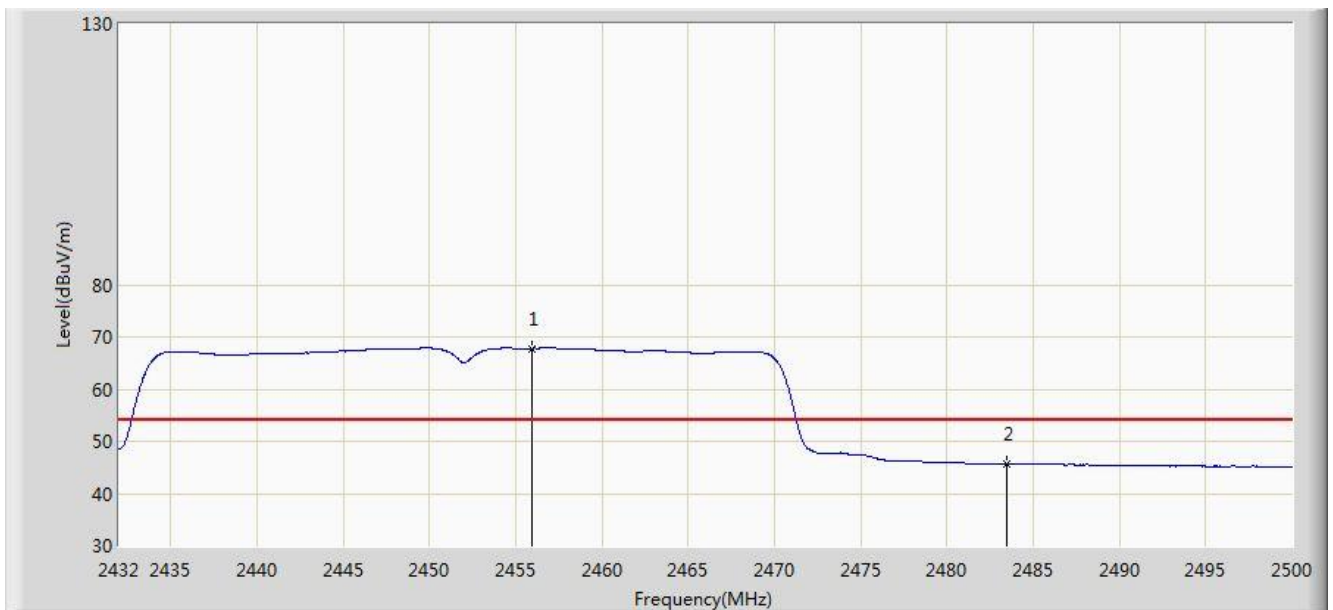

No	Flag	Mark	Frequency (MHz)	Measure Level (dBuV/m)	Reading Level (dBuV)	Over Limit (dB)	Limit (dBuV/m)	Factor (dB)	Type
1		*	2455.970	67.822	36.697	N/A	N/A	31.125	AV
2			2483.500	45.681	14.488	-8.319	54.000	31.194	AV

Note: Measure Level (dB $\mu$ V/m) = Reading Level (dB $\mu$ V) + Factor (dB)

Factor (dB) = Cable Loss (dB) + Antenna Factor (dB/m)

Site: AC1	Time: 2016/07/12 - 09:59
Limit: FCC_Part15.209_RE(3m)	Engineer: Vince Yu
Probe: BBHA9120D_1-18GHz	Polarity: Vertical
EUT: Wireless VOIP Router	Power: AC 120V/60Hz
Test Mode: Transmit by 802.11n-HT40 at Channel 2452MHz Ant 0 + 1	



No	Flag	Mark	Frequency (MHz)	Measure Level (dBuV/m)	Reading Level (dBuV)	Over Limit (dB)	Limit (dBuV/m)	Factor (dB)	Type
1		*	2435.842	108.336	77.209	N/A	N/A	31.127	PK
2			2483.500	70.409	39.216	-3.591	74.000	31.194	PK
3			2485.788	73.059	41.860	-0.941	74.000	31.200	PK

Note: Measure Level (dB $\mu$ V/m) = Reading Level (dB $\mu$ V) + Factor (dB)

Factor (dB) = Cable Loss (dB) + Antenna Factor (dB/m)

Site: AC1	Time: 2016/07/12 - 10:02
Limit: FCC_Part15.209_RE(3m)	Engineer: Vince Yu
Probe: BBHA9120D_1-18GHz	Polarity: Vertical
EUT: Wireless VOIP Router	Power: AC 120V/60Hz
Test Mode: Transmit by 802.11n-HT40 at Channel 2452MHz Ant 0 + 1	

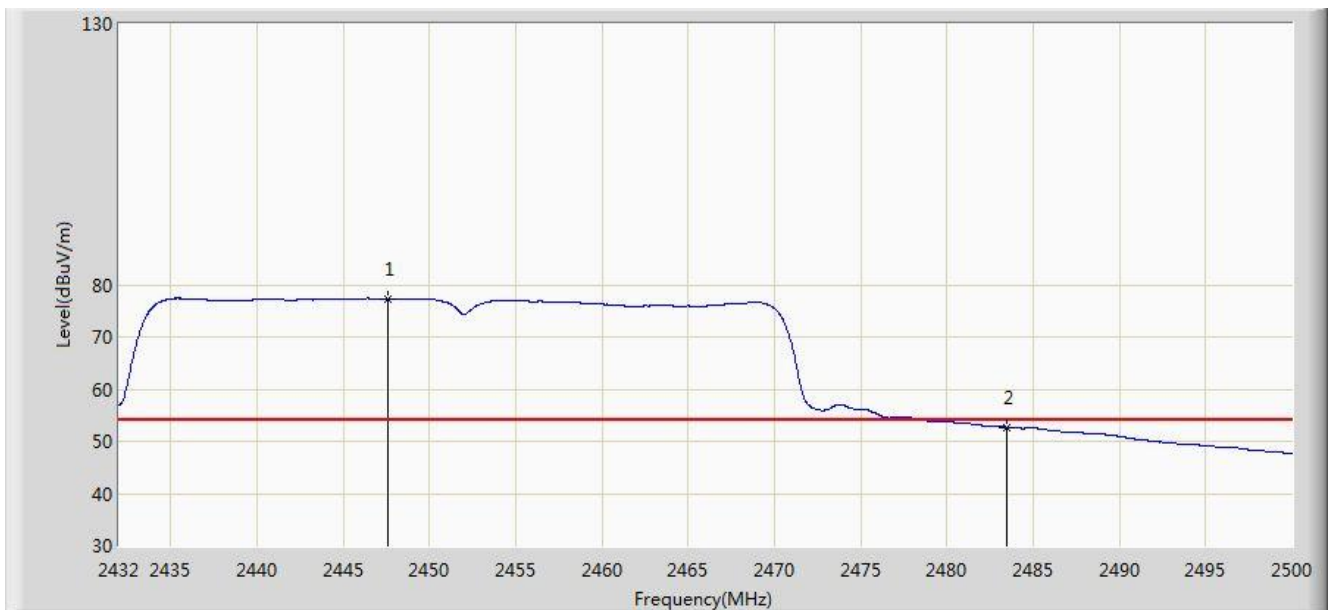

No	Flag	Mark	Frequency (MHz)	Measure Level (dBuV/m)	Reading Level (dBuV)	Over Limit (dB)	Limit (dBuV/m)	Factor (dB)	Type
1		*	2447.606	77.362	46.252	N/A	N/A	31.109	AV
2			2483.500	52.691	21.498	-1.309	54.000	31.194	AV

Note: Measure Level (dB $\mu$ V/m) = Reading Level (dB $\mu$ V) + Factor (dB)

Factor (dB) = Cable Loss (dB) + Antenna Factor (dB/m)



## 7.8. AC Conducted Emissions Measurement

### 7.8.1. Test Limit

FCC Part 15 Subpart C Paragraph 15.207 Limits		
Frequency (MHz)	QP (dBuV)	AV (dBuV)
0.15 - 0.50	66 - 56	56 - 46
0.50 - 5.0	56	46
5.0 - 30	60	50

Note 1: The lower limit shall apply at the transition frequencies.

Note 2: The limit decreases linearly with the logarithm of the frequency in the range 0.15MHz to 0.5MHz.

### 7.8.2. Test Setup

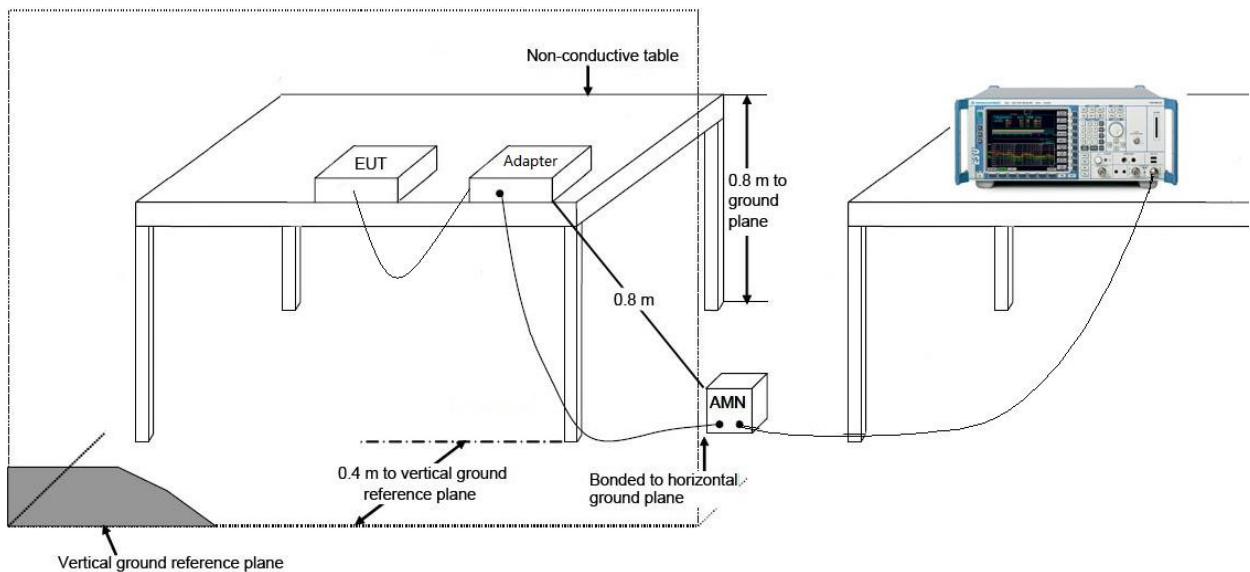

### 7.8.3. Test Result

Site: SR2	Time: 2016/07/16 - 16:26
Limit: FCC_Part15.207_CE	Engineer: Roy Cheng
Probe: ENV216_101683_Filter On	Polarity: Line
EUT: Wireless VOIP Router	Power: AC 120V/60Hz
Note: Mode 1	

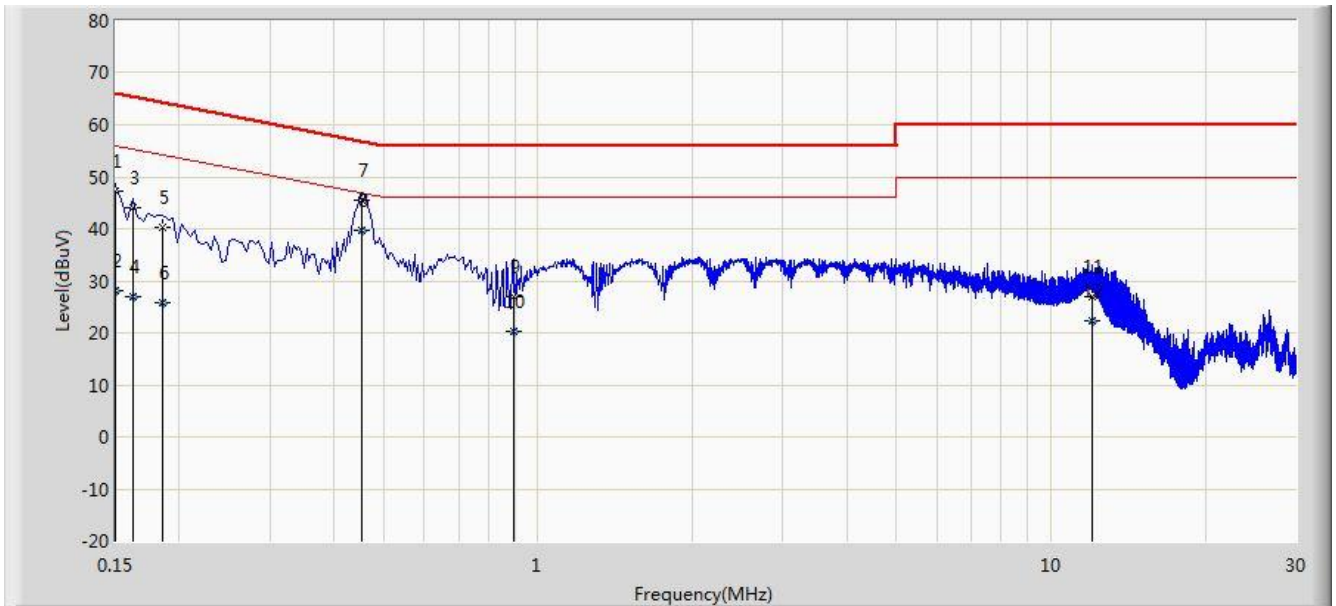

No	Flag	Mark	Frequency (MHz)	Measure Level (dBuV)	Reading Level (dBuV)	Over Limit (dB)	Limit (dBuV)	Factor (dB)	Type
1			0.150	47.348	36.180	-18.652	66.000	11.168	QP
2			0.150	28.258	17.089	-27.742	56.000	11.168	AV
3			0.162	43.964	33.867	-21.397	65.361	10.097	QP
4			0.162	26.816	16.719	-28.544	55.361	10.097	AV
5			0.186	40.322	30.283	-23.892	64.213	10.039	QP
6			0.186	25.714	15.676	-28.499	54.213	10.039	AV
7			0.454	45.382	35.253	-11.420	56.802	10.129	QP
8		*	0.454	39.787	29.657	-7.015	46.802	10.129	AV
9			0.894	27.038	17.074	-28.962	56.000	9.963	QP
10			0.894	20.194	10.230	-25.806	46.000	9.963	AV
11			12.062	26.825	16.740	-33.175	60.000	10.085	QP
12			12.062	22.220	12.136	-27.780	50.000	10.085	AV

Note: Measure Level (dB $\mu$ V) = Reading Level (dB $\mu$ V) + Factor (dB)

Factor (dB) = Cable Loss (dB) + LISN Factor (dB)

Site: SR2	Time: 2016/07/18 - 16:33
Limit: FCC_Part15.207_CE	Engineer: Roy Cheng
Probe: ENV216_101683_Filter On	Polarity: Neutral
EUT: Wireless VOIP Router	Power: AC 120V/60Hz
Note: Mode 1	

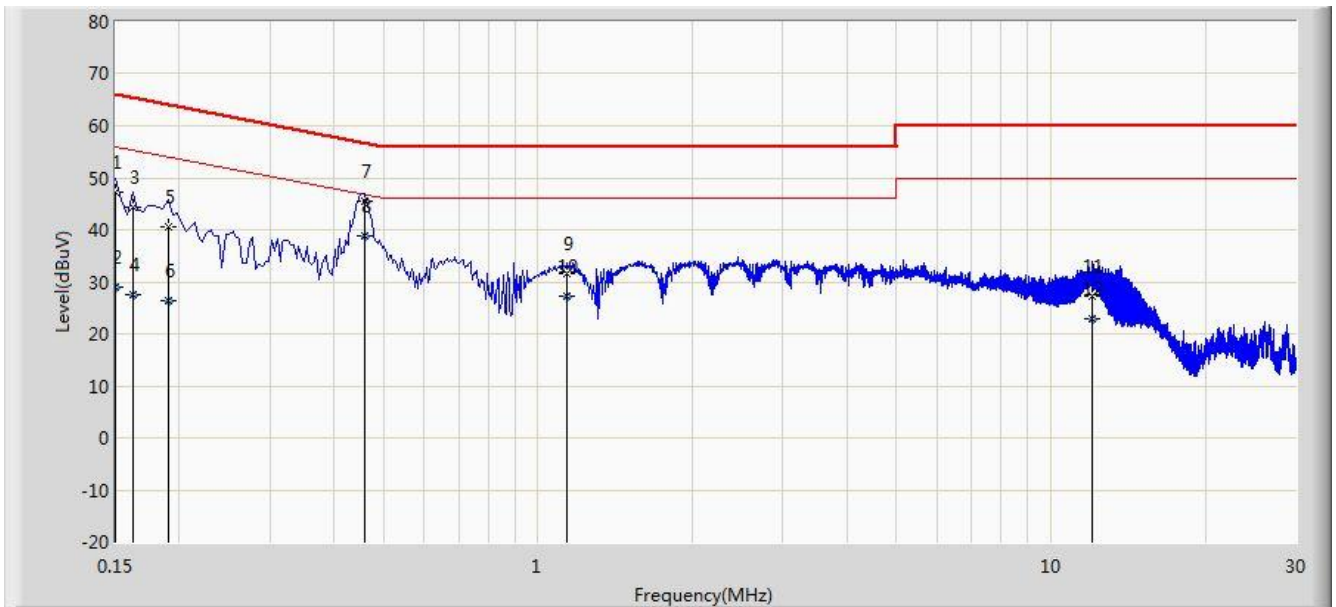

No	Flag	Mark	Frequency (MHz)	Measure Level (dBuV)	Reading Level (dBuV)	Over Limit (dB)	Limit (dBuV)	Factor (dB)	Type
1			0.150	47.250	36.108	-18.750	66.000	11.142	QP
2			0.150	28.994	17.852	-27.006	56.000	11.142	AV
3			0.162	44.350	34.272	-21.011	65.361	10.078	QP
4			0.162	27.578	17.499	-27.783	55.361	10.078	AV
5			0.190	40.523	30.495	-23.513	64.037	10.028	QP
6			0.190	26.499	16.471	-27.537	54.037	10.028	AV
7			0.458	45.607	35.452	-11.121	56.729	10.156	QP
8		*	0.458	38.763	28.607	-7.966	46.729	10.156	AV
9			1.142	31.734	21.830	-24.266	56.000	9.904	QP
10			1.142	27.251	17.347	-18.749	46.000	9.904	AV
11			11.998	27.361	17.249	-32.639	60.000	10.112	QP
12			11.998	22.905	12.794	-27.095	50.000	10.112	AV

Note: Measure Level (dBμV) = Reading Level (dBμV) + Factor (dB)

Factor (dB) = Cable Loss (dB) + LISN Factor (dB)

## 8. CONCLUSION

The data collected relate only the item(s) tested and show that the **Wireless VOIP Router FCC ID: TKZAWV03S** is in compliance with Part 15C of the FCC Rules.

---

The End