



MEASUREMENT REPORT

FCC PART 15 Subpart E- WLAN 802.11a/n/ac

FCC ID: TKZAW2405AC1
APPLICANT: AsiaRF Co., Ltd
Application Type: Certification
Product: WIFI USB DONGLE
Model No.: AW2405-AC1
FCC Classification: Unlicensed National Information Infrastructure (UNII)
FCC Rule Part(s): Part 15 Subpart E (Section 15.407)
Test Procedure(s): ANSI C63.10-2013, KDB 789033 D02v02r01,
KDB 662911 D01v02r01, KDB 644545 D03v01
Test Date: December 18 ~ 26, 2017

Tested By : *Peter Syu*
(Peter Syu)
Reviewed By : *Paddy Chen*
(Paddy Chen)
Approved By : *Chenz Ker*
(Chenz Ker)



The test results relate only to the samples tested.

This equipment has been shown to be capable of compliance with the applicable technical standards as indicated in the measurement report and was tested in accordance with the measurement procedures specified in KDB 789033 D02v02r01. Test results reported herein relate only to the item(s) tested.

The test report shall not be reproduced except in full without the written approval of MRT Technology (Taiwan) Co., Ltd.

Revision History

Report No.	Version	Description	Issue Date	Note
1712TW0106-U3	1.0	Original Report	2017-12-29	

CONTENTS

Description	Page
§2.1033 General Information	5
1. INTRODUCTION	6
1.1. Scope	6
1.2. MRT Test Location	6
2. PRODUCT INFORMATION	7
2.1. Equipment Description.....	7
2.2. Operation Frequencies and Channel List.....	8
2.3. Test Mode	9
2.4. Test Software.....	9
2.5. Device Capabilities	10
2.6. Test Configuration	10
2.7. EMI Suppression Device(s)/Modifications.....	10
2.8. Labeling Requirements.....	10
3. DESCRIPTION OF TEST	11
3.1. Evaluation Procedure	11
3.2. AC Line Conducted Emissions	11
3.3. Radiated Emissions.....	12
4. ANTENNA REQUIREMENTS.....	13
5. TEST EQUIPMENT CALIBRATION DATE.....	14
6. MEASUREMENT UNCERTAINTY.....	15
7. TEST RESULT	16
7.1. Summary.....	16
7.2. 26dB Bandwidth Measurement.....	17
7.2.1. Test Limit	17
7.2.2. Test Procedure used.....	17
7.2.3. Test Setting.....	17
7.2.4. Test Setup	17
7.2.5. Test Result.....	18
7.3. 6dB Bandwidth Measurement.....	22
7.3.1. Test Limit	22
7.3.2. Test Procedure used.....	22
7.3.3. Test Setting.....	22

7.3.4.	Test Setup	22
7.3.5.	Test Result.....	23
7.4.	Output Power Measurement	28
7.4.1.	Test Limit	28
7.4.2.	Test Procedure Used	29
7.4.3.	Test Setting.....	30
7.4.4.	Test Setup	30
7.4.5.	Test Result.....	31
7.5.	Transmit Power Control	33
7.5.1.	Test Limit	33
7.5.2.	Test Procedure Used	33
7.5.3.	Test Setting.....	33
7.5.4.	Test Setup	33
7.5.5.	Test Result.....	34
7.6.	Power Spectral Density Measurement	35
7.6.1.	Test Limit	35
7.6.2.	Test Procedure Used	35
7.6.3.	Test Setting.....	36
7.6.4.	Test Setup	36
7.6.5.	Test Result.....	37
7.7.	Radiated Spurious Emission Measurement	43
7.7.1.	Test Limit	43
7.7.2.	Test Procedure Used	43
7.7.3.	Test Setting.....	43
7.7.4.	Test Setup	45
7.7.5.	Test Result.....	47
7.8.	Radiated Restricted Band Edge Measurement	85
7.8.1.	Test Limit	85
7.8.2.	Test Result.....	88
7.9.	AC Conducted Emissions Measurement	117
7.9.1.	Test Limit	117
7.9.2.	Test Procedure	117
7.9.3.	Test Setup	118
7.9.4.	Test Result.....	119
8.	CONCLUSION	121

§2.1033 General Information

Applicant	AsiaRF Co., Ltd
Applicant Address	3F, 215, Dehe Road, Yonghe Dist. New Taipei City 234, Taiwan
Manufacturer	AsiaRF Co., Ltd
Manufacturer Address	3F, 215, Dehe Road, Yonghe Dist. New Taipei City 234, Taiwan
Test Site	MRT Technology (Taiwan) Co., Ltd
Test Site Address	No. 38, Fuxing Second Rd., Guishan Dist., Taoyuan City 333, Taiwan (R.O.C)
MRT FCC Registration No.	291082
FCC Rule Part(s)	Part 15 Subpart E (Section 15.407)
Test Device Serial No.	N/A <input type="checkbox"/> Production <input checked="" type="checkbox"/> Pre-Production <input type="checkbox"/> Engineering

Test Facility / Accreditations

Measurements were performed at MRT Laboratory located in Fuxing Rd., Taoyuan, Taiwan (R.O.C)

- MRT facility is a FCC registered (Reg. No. 291082) test facility with the site description report on file and is designated by the FCC as an Accredited Test Film.
- MRT facility is an IC registered (MRT Reg. No. 21723-1) test laboratory with the site description on file at Industry Canada.
- MRT Lab is accredited to ISO 17025 by the Taiwan Accreditation Foundation (TAF Cert. No. 3261) in EMC, Telecommunications and Radio testing for FCC, Industry Taiwan, EU and TELEC Rules.

1. INTRODUCTION

1.1. Scope

Measurement and determination of electromagnetic emissions (EMC) of radio frequency devices including intentional and/or unintentional radiators for compliance with the technical rules and regulations of the Federal Communications Commission and the Industry Canada Certification and Engineering Bureau.

1.2. MRT Test Location

The map below shows the location of the MRT LABORATORY, its proximity to the Taoyuan City. These measurement tests were conducted at the MRT Technology (Taiwan) Co., Ltd. Facility located at No.38, Fuxing 2nd Rd., Guishan Dist., Taoyuan City 33377, Taiwan (R.O.C).

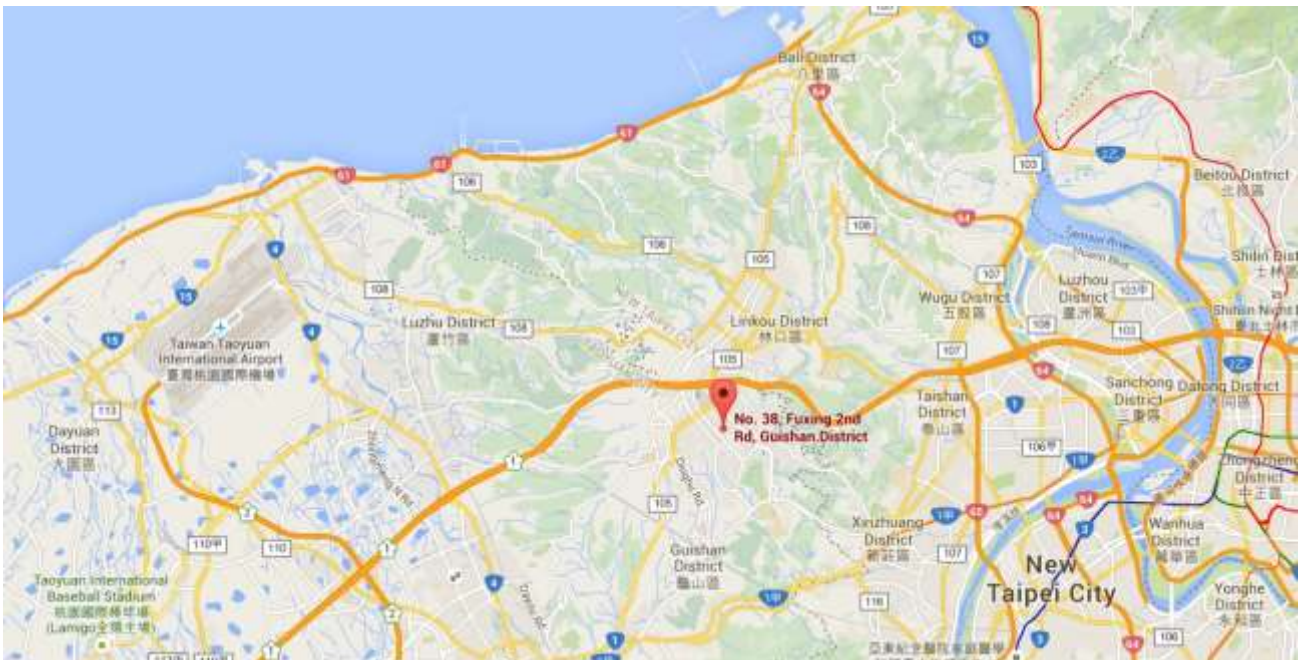

2. PRODUCT INFORMATION

2.1. Equipment Description

Product Name	WIFI USB DONGLE
Model No.	AW2405-AC1
Supports Radios Spec.	WLAN : 2.4G : 802.11b/g/n-20/n-40; 5G : 802.11a/n-20/ac-20/n-40/ac-40/ac-80
Wi-Fi Specification	802.11a/b/g/n/ac
Frequency Range	<p><u>2.4GHz:</u> For 802.11b/g/n-HT20: 2412 ~ 2462 MHz For 802.11n-HT40: 2422 ~ 2452 MHz</p> <p><u>5GHz:</u> For 802.11a/n-HT20/ac-VHT-20: 5180~5240MHz, 5745~5825MHz For 802.11n-HT40/ ac-VHT40: 5190~5230MHz, 5755~5795MHz For 802.11ac-VHT80: 5210MHz, 5775MHz</p>
Maximum Output Power	802.11a: 19.58dBm 802.11n-HT20: 19.33dBm, 802.11n-HT40: 18.99dBm, 802.11ac-VHT80: 20.7dBm
Modulation Type	802.11a/n-20/ac-20/n-40/ac-40/ac-80: OFDM (BPSK, QPSK, 16QAM, 64QAM,256QAM)

2.2. Operation Frequencies and Channel List

802.11 n-HT20/ ac-VHT20

Channel	Frequency	Channel	Frequency	Channel	Frequency
36	5180 MHz	40	5200 MHz	44	5220 MHz
48	5240 MHz	149	5745 MHz	153	5765 MHz
157	5785 MHz	161	5805 MHz	165	5825 MHz

802.11 n-HT40/ ac-VHT40

Channel	Frequency	Channel	Frequency	Channel	Frequency
38	5190 MHz	46	5230 MHz	151	5755 MHz
159	5795 MHz	--	--	--	--

802.11ac-VHT80

Channel	Frequency	Channel	Frequency	Channel	Frequency
42	5210 MHz	155	5775 MHz	--	--

2.3. Test Mode

Test Mode	Mode 1: Transmit by 802.11a
	Mode 2: Transmit by 802.11n-HT20
	Mode 3: Transmit by 802.11n-HT40
	Mode 4: Transmit by 802.11ac-VHT80

2.4. Test Software

The test utility software used during testing was "MT7662UQA".

2.5. Device Capabilities

This device contains the following capabilities:

2.4GHz WLAN (DTS) and 5GHz WLAN (NII).

Note: 5GHz (NII) operation is possible in 20MHz, 40MHz and 80MHz channel bandwidths. The maximum achievable duty cycles for all modes were determined based on measurements performed on a spectrum analyzer in zero-span mode with RBW = 8MHz, VBW = 50MHz, and detector = average per the guidance of Section B)2)b) of KDB 789033 D02v02r01. The RBW and VBW were both greater than $50/T$, where T is the minimum transmission duration, and the number of sweep points across T was greater than 100. The duty cycles are as follows:

Test Mode	Duty Cycle
802.11a	100%
802.11n-HT20	100%
802.11n-HT40	100%
802.11ac-VHT80	100%

2.6. Test Configuration

This device was tested per the guidance of KDB 789033 D02v02r01. ANSI C63.10-2013 was used to reference the appropriate EUT setup for radiated spurious emissions testing and AC line conducted testing.

2.7. EMI Suppression Device(s)/Modifications

No EMI suppression device(s) were added and/or no modifications were made during testing.

2.8. Labeling Requirements

Per 2.1074 & 15.19; Docket 95-19

The label shall be permanently affixed at a conspicuous location on the device; instruction manual or pamphlet supplied to the user and be readily visible to the purchaser at the time of purchase.

However, when the device is so small wherein placement of the label with specified statement is not practical, only the FCC ID must be displayed on the device per Section 15.19(a)(5). Please see attachment for FCC ID label and label location.

3. DESCRIPTION OF TEST

3.1. Evaluation Procedure

The measurement procedures described in the American National Standard for Testing Unlicensed Wireless Devices (ANSI C63.10-2013), and the guidance provided in KDB 789033 were used in the measurement of the device.

Deviation from measurement procedure.....None

3.2. AC Line Conducted Emissions

The line-conducted facility is located inside an 9'x4'x3' shielded enclosure. A 1m x 2m wooden table 80cm high is placed 40cm away from the vertical wall and 80cm away from the sidewall of the shielded room. Two 10kHz-30MHz, 50Ω/50uH Line-Impedance Stabilization Networks (LISNs) are bonded to the shielded room floor. Power to the LISNs is filtered by external high-current high-insertion loss power line filters. These filters attenuate ambient signal noise from entering the measurement lines. These filters are also bonded to the shielded enclosure.

The EUT is powered from one LISN and the support equipment is powered from the second LISN. All interconnecting cables more than 1 meter were shortened to a 1 meter length by non-inductive bundling (serpentine fashion) and draped over the back edge of the test table. All cables were at least 40cm above the horizontal reference ground-plane. Power cables for support equipment were routed down to the second LISN while ensuring that that cables were not draped over the second LISN.

Sufficient time for the EUT, support equipment, and test equipment was allowed in order for them to warm up to their normal operating condition. The RF output of the LISN was connected to the receiver and exploratory measurements were made to determine the frequencies producing the maximum emission from the EUT. The receiver was scanned from 150kHz to 30MHz. The detector function was set to peak mode for exploratory measurements while the bandwidth of the analyzer was set to 9kHz. The EUT, support equipment, and interconnecting cables were arranged and manipulated to maximize each emission. Each emission was also maximized by varying: power lines, the mode of operation or data exchange speed, or support equipment whichever determined the worst-case emission. Once the worst case emissions have been identified, the one EUT cable configuration/arrangement and mode of operation that produced these emissions are used for final measurements on the same test site. The analyzer is set to CISPR quasi-peak and average detectors with a 9kHz resolution bandwidth for final measurements.

An extension cord was used to connect to a single LISN which powered by EUT. The extension cord was calibrated with LISN, the impedance and insertion loss are compliance with the requirements as stated in ANSI C63.10-2013.

Line conducted emissions test results are shown in Section 7.10.

3.3. Radiated Emissions

The radiated test facilities consisted of an indoor 3 meter semi-anechoic chamber used for final measurements and exploratory measurements, when necessary. The measurement area is contained within the semi-anechoic chamber which is shielded from any ambient interference. For measurements above 1GHz absorbers are arranged on the floor between the turn table and the antenna mast in such a way so as to maximize the reduction of reflections. For measurements below 1GHz, the absorbers are removed. A turntable is used for radiated measurement. It is a continuously rotatable, remote controlled, metallic turntable and 2 meters (6.56 ft.) in diameter. The turn table is flush with the raised floor of the chamber in order to maintain its function as a ground plane. An 80cm high PVC support structure is placed on top of the turntable.

For all measurements, the spectrum was scanned through all EUT azimuths and from 1 to 4 meter receive antenna height using a broadband antenna from 30MHz up to the upper frequency shown in 15.33(b)(1) depending on the highest frequency generated or used in the device or on which the device operates or tunes. For frequencies above 1GHz, linearly polarized double ridge horn antennas were used. For frequencies below 30MHz, a calibrated loop antenna was used. When exploratory measurements were necessary, they were performed at 1 meter test distance inside the semi-anechoic chamber using broadband antennas, broadband amplifiers, and spectrum analyzers to determine the frequencies and modes producing the maximum emissions. Sufficient time for the EUT, support equipment, and test equipment was allowed in order for them to warm up to their normal operating condition. The test set-up for frequencies below 1GHz was placed on top of the 0.8 meter high, 1 x 1.5 meter table; and test set-up for frequencies 1-40GHz was placed on top of the 1.5 meter high, 1 x 1.5 meter table. The EUT, support equipment, and interconnecting cables were arranged and manipulated to maximize each emission. Appropriate precaution was taken to ensure that all emissions from the EUT were maximized and investigated. The system configuration, clock speed, mode of operation or video resolution, if applicable, turntable azimuth, and receive antenna height was noted for each frequency found.

Final measurements were made in the semi-anechoic chamber using calibrated, linearly polarized broadband and horn antennas. The test setup was configured to the setup that produced the worst case emissions. The spectrum analyzer was set to investigate all frequencies required for testing to compare the highest radiated disturbances with respect to the specified limits. The turntable containing the EUT was rotated through 360 degrees and the height of the receive antenna was varied 1 to 4 meters and stopped at the azimuth and height producing the maximum emission. Each emission was maximized by changing the orientation of the EUT through three orthogonal planes and changing the polarity of the receive antenna, whichever produced the worst-case emissions. According to 3dB Beam-Width of horn antenna, the horn antenna should be always directed to the EUT when rising height.

4. ANTENNA REQUIREMENTS

Excerpt from §15.203 of the FCC Rules/Regulations:

“An intentional radiator antenna shall be designed to ensure that no antenna other than that furnished by the responsible party can be used with the device. The use of a permanently attached antenna or of an antenna that uses a unique coupling to the intentional radiator shall be considered sufficient to comply with the provisions of this section.”

- The antenna of the **WIFI USB DONGLE**, is permanently attached.
- There are no provisions for connection to an external antenna.

Conclusion:

The EUT unit complies with the requirement of §15.203.

Antenna List

No.	Manufacturer	Part No.	Antenna Type	Peak Gain
1	AsiaRF	AW2405-AC1	PCB	6dBi

5. TEST EQUIPMENT CALIBRATION DATE

Conducted Emissions – SR2

Instrument	Manufacturer	Type No.	Asset No.	Cali. Interval	Cali. Due Date
Two-Line V-Network	R&S	ENV216	MRTTWA00019	1 year	2018.03.15
Cable	Rosnol	N1C50-RG400-B 1C50-500CM	MRTTWE00013	1 year	2018.05.19
EMI Test Receiver	R&S	ESR3	MRTTWA00009	1 year	2018.03.16

Radiated Emissions – AC1

Instrument	Manufacturer	Type No.	Asset No.	Cali. Interval	Cali. Due Date
Broadband TRILOG Antenna	SCHWARZBECK	VULB 9162	MRTTWA00001	1 year	2018.05.14
EMI Test Receiver	R&S	ESR3	MRTTWA00009	1 year	2018.03.16
Active Loop Antenna	Schwarzbeck	FMZB 1519B	MRTTWA00002	1 year	2018.04.13
Broadband Horn antenna	SCHWARZBECK	BBHA 9120D	MRTTWA00003	1 year	2018.04.17
Breitband Hornantenna	Schwarzbeck	BBHA 9170	MRTTWA00004	1 year	2018.04.24
Broadband Amplifier	Schwarzbeck	BBV 9721	MRTTWA00006	1 year	2018.04.24
Broadband Preampfier	SCHWARZBECK	BBV 9718	MRTTWA00005	1 year	2018.04.19
Cable	HUBERSUHNER	SF106	MRTTWA00010	1 year	2018.05.19
Cable	Rosnol	K1K50-UP0264- K1K50-4M	MRTTWA00012	1 year	2018.05.19

Conducted Test Equipment – SR2

Instrument	Manufacturer	Type No.	Asset No.	Cali. Interval	Cali. Due Date
Spectrum Analyzer	KEYSIGHT	N9010A	MRTTWA00012	1 year	2018.07.24
USB Wideband Power Sensor	KEYSIGHT	U2021XA	MRTTWA00015	1 year	2018.03.19

Test Software

Software	Version	Function
e3	9.160520a	EMI Test Software
EMI	V3	EMI Test Software

6. MEASUREMENT UNCERTAINTY

Where relevant, the following test uncertainty levels have been estimated for tests performed on the EUT as specified in CISPR 16-4-2. This uncertainty represents an expanded uncertainty expressed at approximately the 95% confidence level using a coverage factor of $k = 2$.

AC Conducted Emission Measurement – SR2
Measuring Uncertainty for a Level of Confidence of 95% ($U=2Uc(y)$): 150kHz~30MHz: 2.42dB
Conducted Measurement– SR1
Measuring Uncertainty for a Level of Confidence of 95% ($U=2Uc(y)$): 1.3dB
Radiated Emission Measurement – AC1
Measuring Uncertainty for a Level of Confidence of 95% ($U=2Uc(y)$): Horizontal: 9K~30MHz: 4.14dB 30MHz~1GHz: 4.22dB 1GHz~40GHz: 4.05dB Vertical: 9K~30MHz: 4.14dB 30MHz~1GHz: 3.37dB 1GHz~40GHz: 4.08dB

7. TEST RESULT

7.1. Summary

Company Name: WIFI USB DONGLE

Model No.: AW2405-AC1

FCC Section(s)	Test Description	Test Limit	Test Condition	Test Result	Reference
15.407(a)	26dB Bandwidth	N/A	Conducted	Pass	Section 7.2
15.407(e)	6dB Bandwidth	$\geq 500\text{kHz}$		Pass	Section 7.3
RSS-247	Unwanted emission limits(5150-5250 MHz)	$\geq 26\text{dBc}$		N/A	Section 7.4
15.407(a)(1)(i), (2), (3)	Maximum Conducted Output Power	Refer to Section 7.5		Pass	Section 7.5
15.407(h)(1)	Transmit Power Control	$\leq 24\text{ dBm}$		N/A	Section 7.6
15.407(a)(1)(i), (2), (3), (5)	Power Spectral Density	Refer to Section 7.7		Pass	Section 7.7
15.407(b)(1), (4)	Undesirable Emissions	$\leq -27\text{dBm/MHz EIRP}$ $\leq -17\text{dBm/MHz EIRP}$	Radiated	Pass	Section 7.8 & 7.9
15.205, 15.209 15.407(b)(5), (6), (7)	General Field Strength Limits (Restricted Bands and Radiated Emission Limits)	Emissions in restricted bands must meet the radiated limits detailed in 15.209		Pass	
15.207	AC Conducted Emissions 150kHz - 30MHz	< FCC 15.207 limits	Line Conducted	Pass	Section 7.10

Notes:

- 1) All channels, modes, and modulations/data rates were investigated among all UNII bands. The test results shown in the following sections represent the worst case emissions.
- 2) The analyzer plots shown in this section were all taken with a correction table loaded into the analyzer. The correction table was used to account for the losses of the cables and attenuators used as part of the system to connect the EUT to the analyzer at all frequencies of interest.

7.2. 26dB Bandwidth Measurement

7.2.1. Test Limit

N/A

7.2.2. Test Procedure used

KDB 789033 D02v02r01 - Section C.1

7.2.3. Test Setting

1. The analyzers' automatic bandwidth measurement capability was used to perform the 26dB bandwidth measurement. The "X" dB bandwidth parameter was set to $X = 26$. The automatic bandwidth measurement function also has the capability of simultaneously measuring the 99% occupied bandwidth. The bandwidth measurement was not influenced by any intermediated power nulls in the fundamental emission.
2. RBW = approximately 1% of the emission bandwidth.
3. VBW $\geq 3 \times$ RBW.
4. Detector = Peak.
5. Trace mode = max hold.

7.2.4. Test Setup

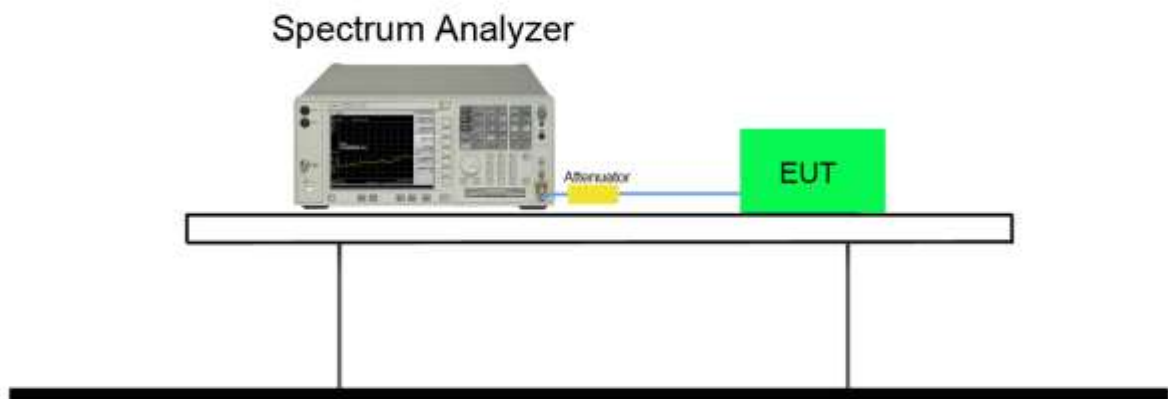

7.2.5. Test Result

Product	WIFI USB DONGLE	Test Engineer	Peter
Test Site	SR2	Test Date	2017/12/26
Test Item	26dB Bandwidth		

Test Mode	Channel No.	Frequency (MHz)	26dB Bandwidth (MHz)	99% Bandwidth (MHz)
802.11a	36	5180	20.07	16.60
802.11a	44	5220	19.71	16.63
802.11a	48	5240	19.79	16.49
802.11a	149	5745	26.88	16.65
802.11a	157	5785	28.50	16.91
802.11a	165	5825	29.62	16.84
802.11n-HT20	36	5180	19.99	17.67
802.11n-HT20	44	5220	20.28	17.66
802.11n-HT20	48	5240	19.97	17.65
802.11n-HT20	149	5745	29.83	17.81
802.11n-HT20	157	5785	28.97	17.80
802.11n-HT20	165	5825	30.56	17.85
802.11n-HT40	38	5190	39.62	35.82
802.11n-HT40	46	5230	39.83	36.08
802.11n-HT40	151	5755	66.73	36.34
802.11n-HT40	159	5795	65.12	36.24
802.11ac-VHT80	42	5210	79.89	74.79
802.11ac-VHT80	155	5775	80.43	74.99

802.11a 26dB Bandwidth & 99% Bandwidth
Channel 36 (5180MHz)

Channel 44 (5220MHz)

Channel 48 (5240MHz)

Channel 149 (5745MHz)

Channel 157 (5785MHz)

Channel 165 (5825MHz)

802.11n-HT20 26dB Bandwidth & 99% Bandwidth
Channel 36 (5180MHz)

Channel 44 (5220MHz)

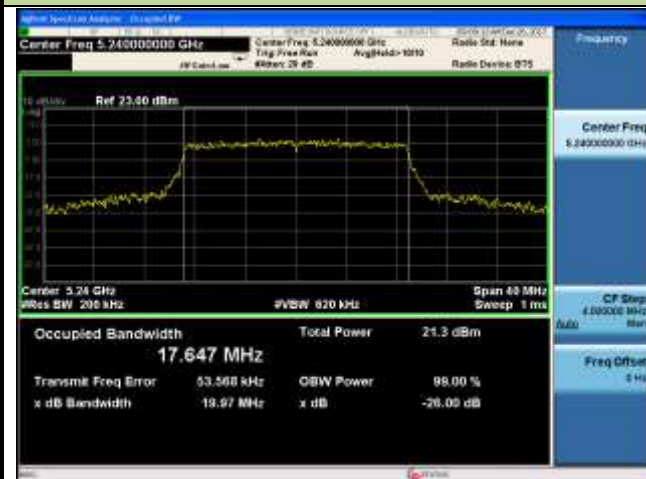
Channel 48 (5240MHz)

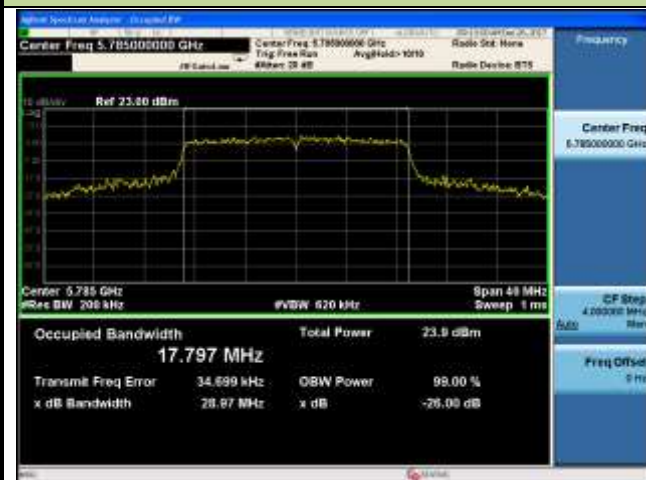
Channel 149 (5745MHz)

Channel 157 (5785MHz)

Channel 165 (5825MHz)

802.11n-HT40 26dB Bandwidth & 99% Bandwidth

Channel 38 (5190MHz)



Channel 46 (5230MHz)



Channel 151 (5755MHz)



Channel 159 (5795MHz)



802.11ac-VHT80 26dB Bandwidth & 99% Bandwidth

Channel 42 (5210MHz)

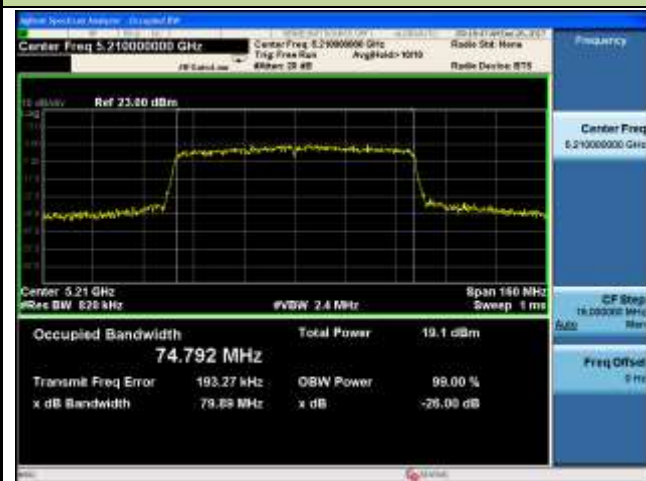

Channel 155 (5775MHz)



7.3. 6dB Bandwidth Measurement

7.3.1. Test Limit

The minimum 6dB bandwidth shall be at least 500 kHz.

7.3.2. Test Procedure used

KDB 789033 D02v02r01 - Section C.2

7.3.3. Test Setting

1. Set center frequency to the nominal EUT channel center frequency.
2. RBW = 100 kHz.
3. VBW $\geq 3 \times$ RBW.
4. Detector = Peak.
5. Trace mode = max hold.
6. Sweep = auto couple.
7. Allow the trace to stabilize.
8. Measure the maximum width of the emission that is constrained by the frequencies associated with the two outermost amplitude points (upper and lower frequencies) that are attenuated by 6 dB relative to the maximum level measured in the fundamental emission.

7.3.4. Test Setup

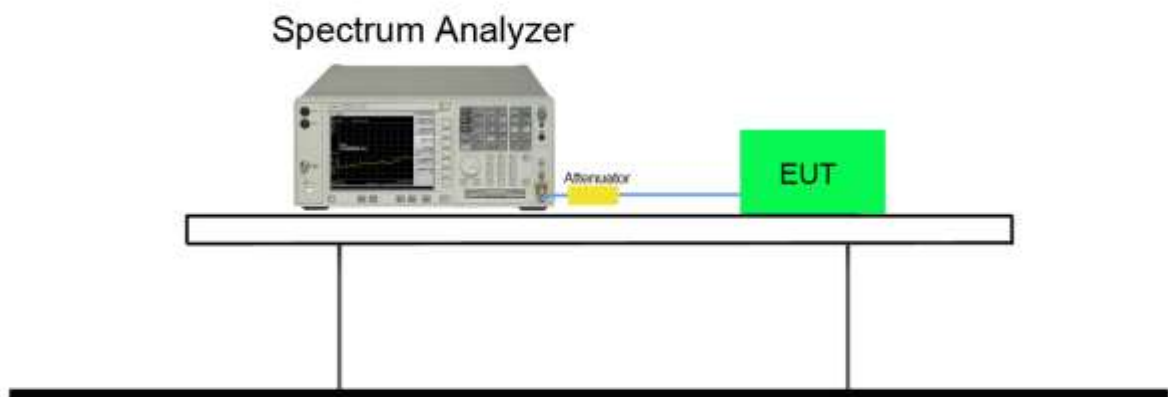

7.3.5. Test Result

Product	WIFI USB DONGLE	Test Engineer	Peter
Test Site	SR2	Test Date	2017/12/26
Test Item	6dB Bandwidth		

Test Mode	Channel No.	Frequency (MHz)	6dB Bandwidth (MHz)	Limit (MHz)	Result
802.11a	149	5745	16.43	≥ 0.5	Pass
802.11a	157	5785	16.42	≥ 0.5	Pass
802.11a	165	5825	16.46	≥ 0.5	Pass
802.11n-HT20	149	5745	17.64	≥ 0.5	Pass
802.11n-HT20	157	5785	17.68	≥ 0.5	Pass
802.11n-HT20	165	5825	17.65	≥ 0.5	Pass
802.11n-HT40	151	5755	36.41	≥ 0.5	Pass
802.11n-HT40	159	5795	36.39	≥ 0.5	Pass
802.11ac-VHT80	155	5775	75.67	≥ 0.5	Pass

802.11a 6dB Bandwidth

Channel 149 (5745MHz)



Channel 157 (5785MHz)



Channel 165 (5825MHz)



802.11n-HT20 6dB Bandwidth

Channel 149 (5745MHz)

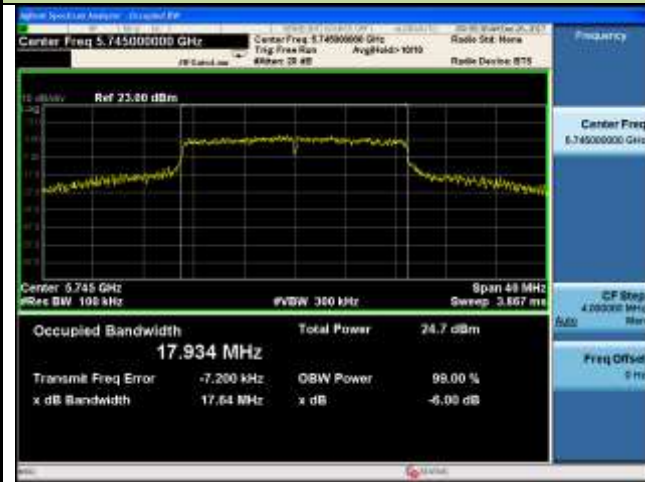

Channel 157 (5785MHz)



Channel 165 (5825MHz)

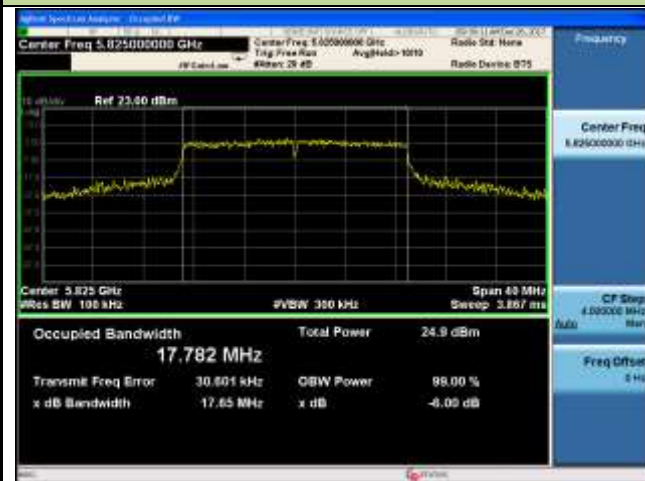

802.11n-HT40 6dB Bandwidth

Channel 151 (5755MHz)



Channel 159 (5795MHz)



802.11ac-VHT80 6dB Bandwidth

Channel 155 (5775MHz)



7.4. Output Power Measurement

7.4.1. Test Limit

For FCC Power Measurement Limit

For client operating in the band 5.15-5.25 GHz, the maximum conducted output power over the frequency band of operation shall not exceed 250mW.

For the 5.25-5.35 GHz and 5.47-5.725 GHz bands, the maximum conducted output power over the frequency bands of operation shall not exceed the lesser of 250 mW (23.98dBm) or $11\text{dBm} + 10 \log$ (26dB BW).

For the band 5.725-5.85 GHz, the maximum conducted output power over the frequency band of operation shall not exceed 1 W (30dBm).

If transmitting antennas of directional gain greater than 6dBi are used, the maximum conducted output power shall be reduced by the amount in dB that the directional gain of the antenna exceeds 6dBi.

For IC Power Measurement Limit

For the band 5.15-5.25 GHz, the maximum e.i.r.p. shall not exceed 200 mW (23.01dBm) or $10 + 10 \cdot \log_{10} B$, dBm, whichever power is less. B is the 99% emission bandwidth in MHz.

For the 5.25-5.35 GHz and 5.47-5.725 GHz bands, the maximum conducted output power shall not exceed 250 mW (23.98dBm) or $11 + 10 \log_{10} B$, dBm, whichever power is less. The maximum e.i.r.p. shall not exceed 1.0 W (30dBm) or $17 + 10 \log_{10} B$, dBm, whichever power is less. B is the 99% emission bandwidth in MHz.

For the 5.725-5.85 GHz band, the maximum conducted output power shall not exceed 1 W.

If transmitting antennas of directional gain greater than 6dBi are used, the maximum conducted output power shall be reduced by the amount in dB that the directional gain of the antenna exceeds 6dBi.

EIRP Limit Calculation as below:

For 5150-5250MHz

$$802.11a: 10 + 10 \log_{10} (16.63\text{MHz}) = 22.20\text{dBm} < 23.01\text{dBm};$$

$$802.11n\text{-HT20}: 10 + 10 \log_{10} (17.67\text{MHz}) = 22.47\text{dBm} < 23.01\text{dBm};$$

$$802.11n\text{-HT40}/ac\text{-VHT80}: 10 + 10 \log_{10} B > 23.01\text{dBm};$$

For 5250-5350MHz, 5470-5725MHz

$$802.11a: 17 + 10 \log_{10} (\text{N/A}) = \text{N/A} < 30\text{dBm};$$

$$802.11n\text{-HT20}: 17 + 10 \log_{10} (\text{N/A}) = \text{N/A} < 30\text{dBm};$$

$$802.11n\text{-HT40}/ac\text{-VHT80}: 10 + 10 \log_{10} B > 30\text{dBm};$$

Max Conducted Output Power Limit Calculation as below:

For 5250-5350MHz, 5470-5725MHz

$$802.11a: 11 + 10 \log_{10} (\text{N/A}) = \text{N/A} < 23.98\text{dBm};$$

$$802.11n\text{-HT20}: 11 + 10 \log_{10} (\text{N/A}) = \text{N/A} < 23.98\text{dBm};$$

$$802.11n\text{-HT40}/ac\text{-VHT80}: 11 + 10 \log_{10} B > 23.98\text{dBm};$$

7.4.2. Test Procedure Used

KDB 789033 D02v02r01 - Section E) 3) b) Method PM-G

7.4.3. Test Setting

Average power measurements perform only when the EUT was transmitting at its maximum power control level using a broadband power meter with a pulse sensor. The power meter implemented triggering and gating capabilities which were set up such that power measurements were recorded only during the ON time of the transmitter. The trace was averaged over 100 traces to obtain the final measured average power.

7.4.4. Test Setup

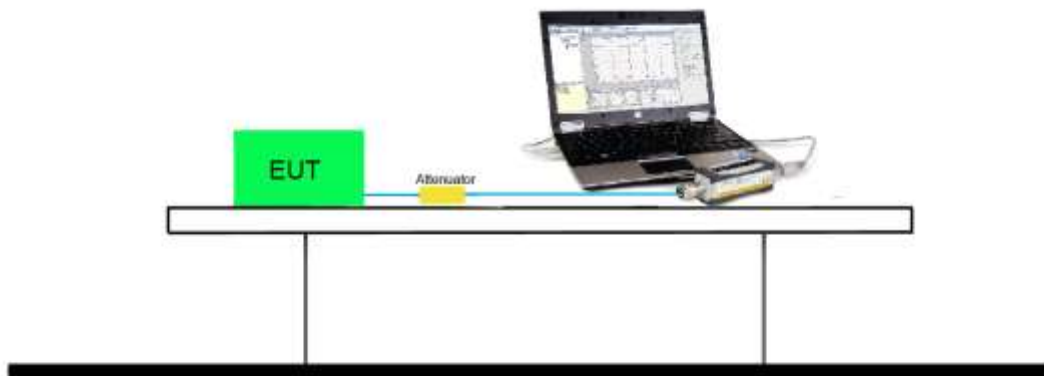

7.4.5. Test Result

Product	WIFI USB DONGLE	Test Engineer	Peter
Test Site	SR2	Test Date	2017/12/25
Test Item	Output Power		

802.11a										
Channel No.	Frequency (MHz)	Average Power								Required Limit (dBm)
		For different Data Rate (Mbps)								
		6	9	12	18	24	36	48	54	
36	5180	14.98	--	--	--	--	--	--	--	≤ 23.98
44	5220	15.85	15.62	15.35	15.14	15.01	14.32	13.55	12.8	≤ 23.98
48	5240	13.19	--	--	--	--	--	--	--	≤ 23.98
149	5745	19.09	--	--	--	--	--	--	--	≤ 30
157	5785	18.58	18.24	18.02	17.94	17.85	17.01	16.84	15.73	≤ 30
165	5825	19.58	--	--	--	--	--	--	--	≤ 30

802.11n-20M										
Channel No.	Frequency (MHz)	Average Power								Required Limit (dBm)
		For different Data Rate (Mbps)								
		MCS0	MCS1	MCS2	MCS3	MCS4	MCS5	MCS6	MCS7	
36	5180	14.47	--	--	--	--	--	--	--	≤ 23.98
44	5220	16.4	16.01	15.47	14.52	13.59	13.52	13.49	13.44	≤ 23.98
48	5240	15.65	--	--	--	--	--	--	--	≤ 23.98
149	5745	18.78	--	--	--	--	--	--	--	≤ 30
157	5785	18.09	17.95	17.25	16.54	15.08	15.05	15.04	15.03	≤ 30
165	5825	19.33	--	--	--	--	--	--	--	≤ 30

802.11n-40M										
Channel No.	Frequency (MHz)	Average Power								Required Limit (dBm)
		For different Data Rate (Mbps)								
		MCS0	MCS1	MCS2	MCS3	MCS4	MCS5	MCS6	MCS7	
38	5190	10.22	--	--	--	--	--	--	--	≤ 23.98
46	5230	16.45	15.98	15.42	14.55	13.12	13.11	13.1	13.09	≤ 23.98
151	5755	18.99	--	--	--	--	--	--	--	≤ 30
159	5795	18.64	18.14	17.56	16.85	15.66	15.65	15.64	15.63	≤ 30

802.11ac-80M												
Channel No.	Frequency (MHz)	Average Power										Required Limit (dBm)
		For different Data Rate (Mbps)										
		MCS0	MCS1	MCS2	MCS3	MCS4	MCS5	MCS6	MCS7	MCS8	MCS9	
42	5210	12.24	11.94	11.14	10.23	8.94	8.94	8.93	8.93	8.92	8.92	≤ 23.98
155	5775	20.7	20.41	20.02	19.36	18.63	18.62	18.62	18.61	18.6	18.58	≤ 30

7.5. Transmit Power Control

7.5.1. Test Limit

The U-NII device is required to have the capability to operate at least 6 dB below the mean EIRP value of 30 dBm.

7.5.2. Test Procedure Used

KDB 789033 D02v02r01 - Section E) 3) b) Method PM-G

7.5.3. Test Setting

Average power measurements were performed only when the EUT was transmitting at its maximum power control level using a broadband power meter with a pulse sensor. The power meter implemented triggering and gating capabilities which were set up such that power measurements were recorded only during the ON time of the transmitter. The trace was averaged over 100 traces to obtain the final measured average power.

7.5.4. Test Setup

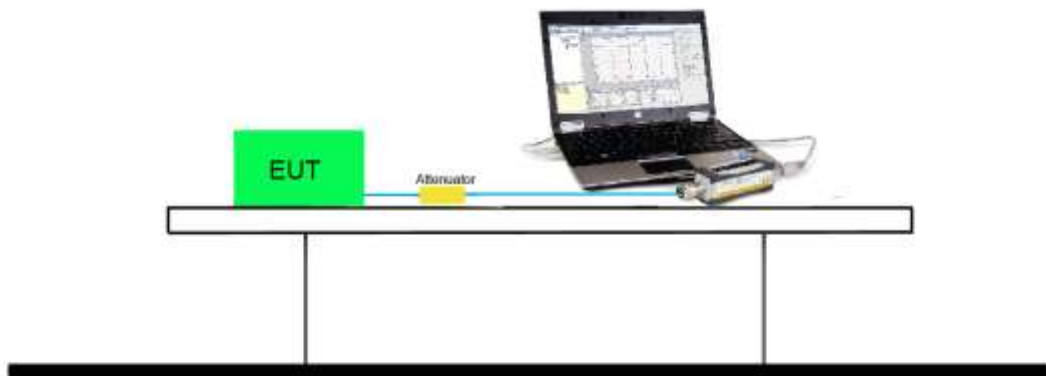

7.5.5. Test Result

A TPC mechanism is not required for systems with an e.i.r.p. of less than 500 mW.

7.6. Power Spectral Density Measurement

7.6.1. Test Limit

For FCC Power Spectral Density Limit

For an outdoor access point operating in the band 5.15-5.25 GHz, the maximum power spectral density shall not exceed 17 dBm in any 1 megahertz band.

For the 5.25-5.35 GHz and 5.47-5.725 GHz bands, the maximum power spectral density shall not exceed 11 dBm in any 1 megahertz band.

For the band 5.725-5.85 GHz, the maximum power spectral density shall not exceed 30 dBm in any 500-kHz band.

If transmitting antennas of directional gain greater than 6dBi are used, the peak power spectral density shall be reduced by the amount in dB that the directional gain of the antenna exceeds 6dBi.

For IC Power Spectral Density Limit

For the band 5.15-5.25 GHz, the e.i.r.p. spectral density shall not exceed 10 dBm in any 1.0 MHz band.

For the 5.25-5.35 GHz and 5.47-5.725 GHz bands, the power spectral density shall not exceed 11 dBm in any 1.0 MHz band.

For the 5.725-5.85 GHz band, the power spectral density shall not exceed 30 dBm in any 500 kHz band.

7.6.2. Test Procedure Used

KDB 789033 D02v02r01 - Section F

7.6.3. Test Setting

1. Analyzer was set to the center frequency of the UNII channel under investigation
2. Span was set to encompass the entire 26dB EBW of the signal.
3. RBW = 1MHz, if measurement bandwidth of Maximum PSD is specified in 500 kHz,
4. RBW = 100 kHz
5. VBW = 3MHz
6. Number of sweep points $\geq 2 \times (\text{span} / \text{RBW})$
7. Detector = power averaging (Average)
8. Sweep time = auto
9. Trigger = free run
10. Use the peak search function on the instrument to find the peak of the spectrum and record its value.
11. Add $10 \cdot \log(1/x)$, where x is the duty cycle, to the measured power in order to compute the average power during the actual transmission times (because the measurement represents an average over both the on and off times of the transmission). For example, add $10 \cdot \log(1/0.25) = 6$ dB if the duty cycle is 25 percent.
12. When the measurement bandwidth of Maximum PSD is specified in 500 kHz, add a constant factor $10 \cdot \log(500\text{kHz}/100\text{kHz}) = 7$ dB to the measured result

7.6.4. Test Setup

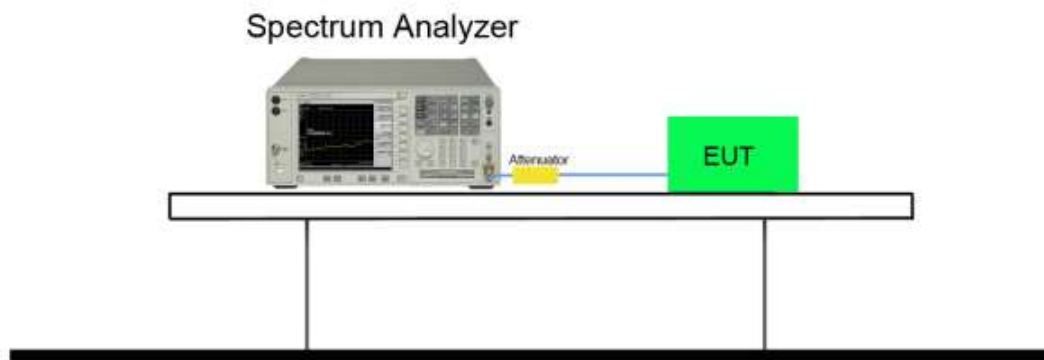

7.6.5. Test Result

Product	WIFI USB DONGLE	Test Engineer	Peter
Test Site	SR2	Test Date	2017/12/26
Test Item	Power Spectral Density		

For FCC bands (UNII-1)

Test Mode	Data Rate (Mbps)	Channel No.	Freq. (MHz)	PSD (dBm/MHz)	Duty Cycle (%)	Total PSD (dBm/MHz)	PSD Limit (dBm/MHz)	EIRP PSD (dBm/MHz)	EIRP PSD Limit (dBm/MHz)	Result
11a	6	36	5180	6.03	100	6.03	≤ 11	12.03	≤ 17	Pass
11a	6	44	5220	5.83	100	5.83	≤ 11	11.83	≤ 17	Pass
11a	6	48	5240	5.40	100	5.40	≤ 11	11.4	≤ 17	Pass
11n-HT20	6.5	36	5180	3.36	100	3.36	≤ 11	9.36	≤ 17	Pass
11n-HT20	6.5	44	5220	5.32	100	5.32	≤ 11	11.32	≤ 17	Pass
11n-HT20	6.5	48	5240	5.00	100	5.00	≤ 11	11	≤ 17	Pass
11n-HT40	13.5	38	5190	-2.65	100	-2.65	≤ 11	3.35	≤ 17	Pass
11n-HT40	13.5	46	5230	2.73	100	2.73	≤ 11	8.73	≤ 17	Pass
11ac-VHT80	29.3	42	5210	-4.68	100	-4.68	≤ 11	1.32	≤ 17	Pass

Note 1: When EUT duty cycle < 98%, the total PSD = Ant PSD (dBm/MHz) + 10*log(1/duty cycle),

Note 2: EIRP PSD (dBm/MHz) = Total PSD (dBm/MHz) + Antenna Gain (dBi)

For FCC bands (UNII-4)

Test Mode	Data Rate (Mbps)	Channel No.	Freq. (MHz)	PSD (dBm/100kHz)	Duty Cycle (%)	Constant Factor	Total PSD (dBm/500kHz)	Limit (dBm/500kHz)	Result
11a	6	149	5745	-1.58	100	7	5.419	≤ 30	Pass
11a	6	157	5785	-0.81	100	7	6.189	≤ 30	Pass
11a	6	165	5825	0.07	100	7	7.067	≤ 30	Pass
11n-HT20	6.5	149	5745	-0.76	100	7	6.245	≤ 30	Pass
11n-HT20	6.5	157	5785	-2.93	100	7	4.067	≤ 30	Pass
11n-HT20	6.5	165	5825	-1.13	100	7	5.870	≤ 30	Pass
11n-HT40	13.5	151	5755	-4.82	100	7	2.183	≤ 30	Pass
11n-HT40	13.5	159	5795	-4.29	100	7	2.708	≤ 30	Pass
11ac-VHT80	29.3	155	5775	-5.82	100	7	1.182	≤ 30	Pass

Note: Total PSD (dBm/500kHz) = Ant PSD (dBm/100kHz) + 10*log(1/duty cycle) + Constant Factor.

802.11a Power Spectral Density

Channel 36 (5180MHz)

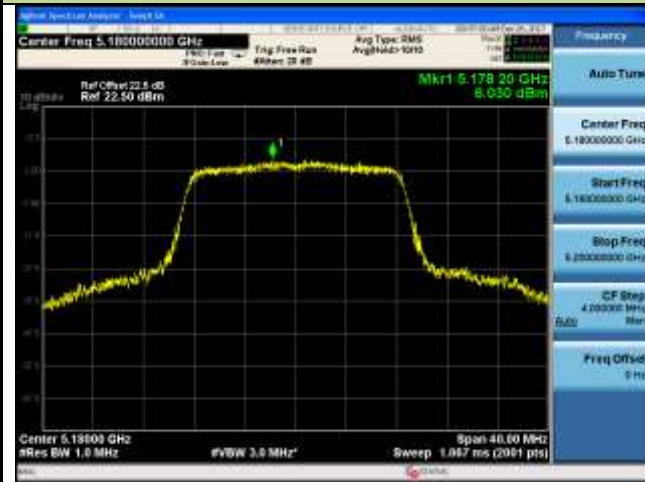

Channel 44 (5220MHz)



Channel 48 (5240MHz)

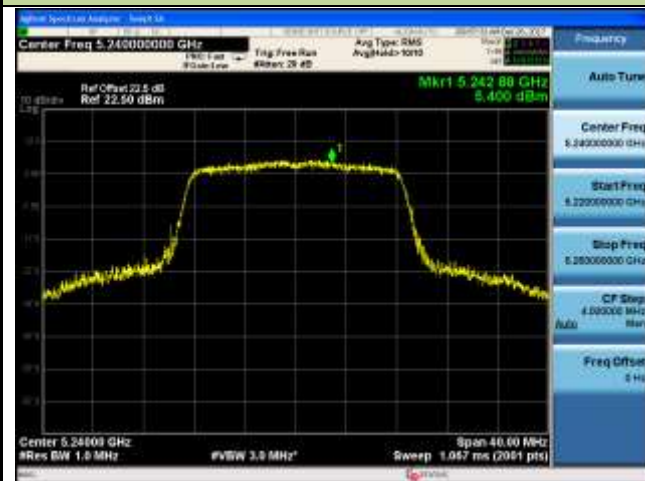

Channel 149 (5745MHz)

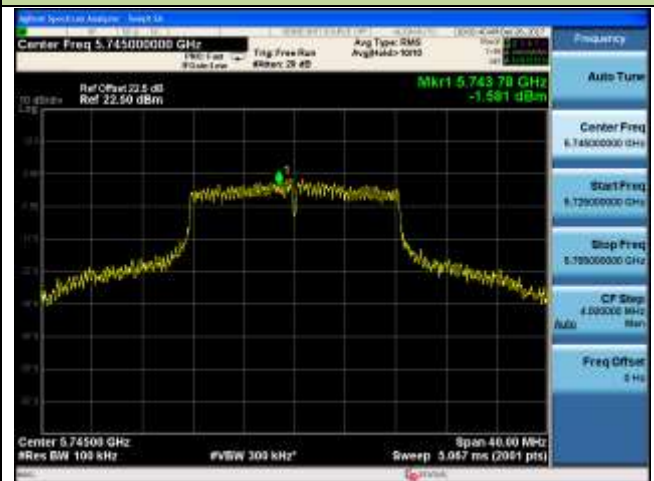

Channel 157 (5785MHz)



Channel 165 (5825MHz)

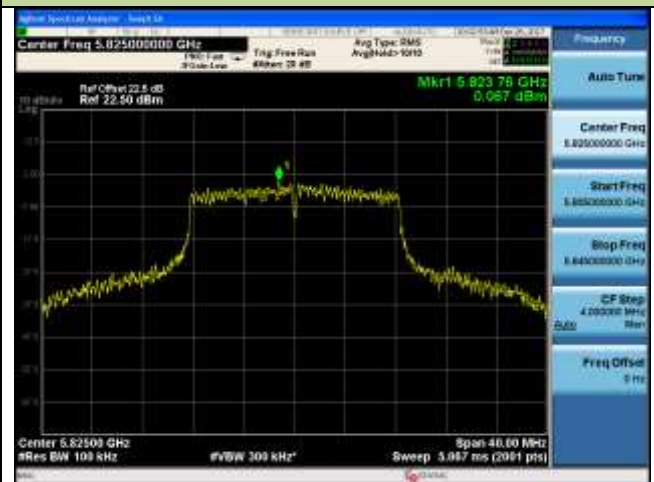

802.11n-HT20 Power Spectral Density

Channel 36 (5180MHz)

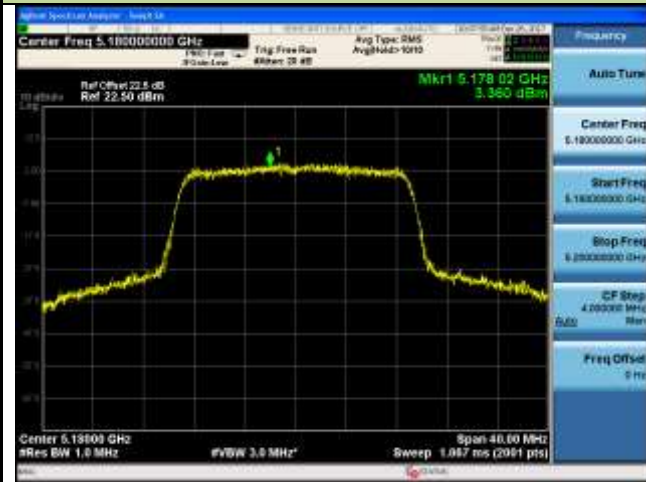

Channel 44 (5220MHz)



Channel 48 (5240MHz)

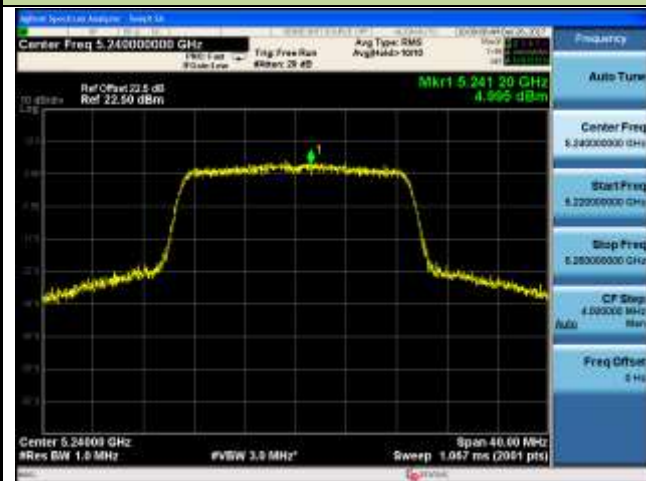

Channel 149 (5745MHz)

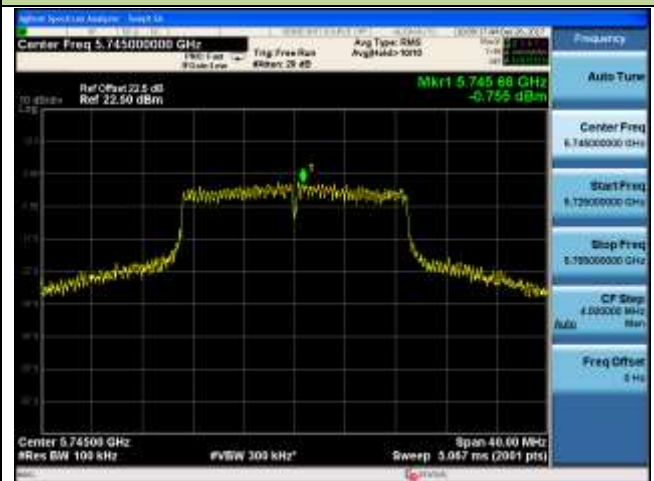

Channel 157 (5785MHz)

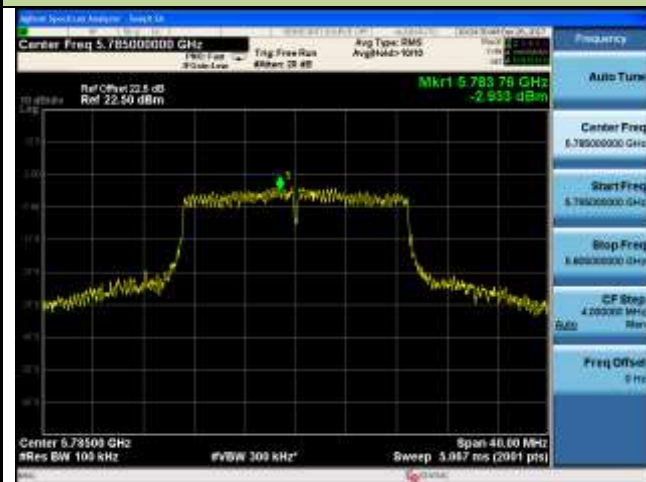

Channel 165 (5825MHz)

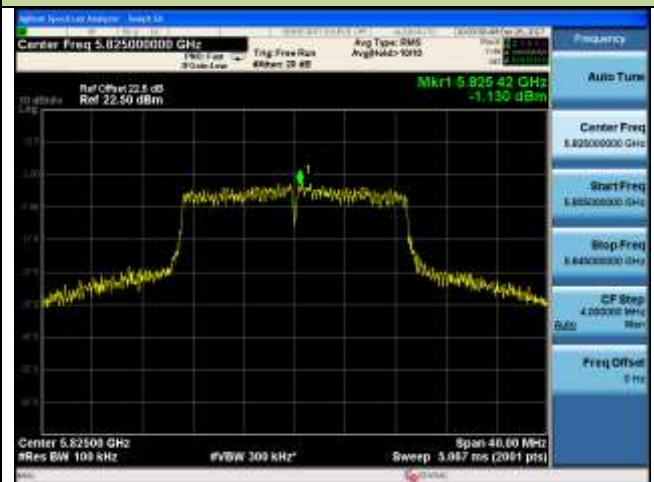

802.11n-HT40 Power Spectral Density

Channel 38 (5190MHz)



Channel 46 (5230MHz)



Channel 151 (5755MHz)



Channel 159 (5795MHz)



802.11ac-VHT80 Power Spectral Density

Channel 42 (5210MHz)



Channel 155 (5775MHz)



7.7. Radiated Spurious Emission Measurement

7.7.1. Test Limit

All out of band emissions appearing in a restricted band as specified in Section 15.205 of the Title 47 CFR must not exceed the limits shown in Table per Section 15.209.

FCC Part 15 Subpart C Paragraph 15.209		
Frequency [MHz]	Field Strength [V/m]	Measured Distance [Meters]
0.009 – 0.490	2400/F (kHz)	300
0.490 – 1.705	24000/F (kHz)	30
1.705 - 30	30	30
30 - 88	100	3
88 - 216	150	3
216 - 960	200	3
Above 960	500	3

7.7.2. Test Procedure Used

KDB 789033 D02v02r01 – Section G

7.7.3. Test Setting

Peak Measurements above 1GHz

1. Analyzer center frequency was set to the frequency of the radiated spurious emission of interest
2. RBW = 1MHz
3. VBW = 3MHz
4. Detector = peak
5. Sweep time = auto couple
6. Trace mode = max hold
7. Trace was allowed to stabilize

Quasi-Peak Measurements below 1GHz

1. Analyzer center frequency was set to the frequency of the radiated spurious emission of interest
2. Span was set greater than 1MHz
3. RBW = 120 kHz
4. Detector = CISPR quasi-peak
5. Sweep time = auto couple
6. Trace was allowed to stabilize

Average Measurements above 1GHz (Method AD)

1. Analyzer center frequency was set to the frequency of the radiated spurious emission of interest
2. RBW = 1MHz
3. VBW = 3MHz
4. Detector = power average (Average)
5. Number of measurement points = 1001 (Number of points must be $> 2 \times \text{span/RBW}$)
6. Sweep time = auto
7. Trace was averaged over at 100 sweeps

Quasi-Peak & Average Measurements below 30MHz

1. Analyzer center frequency was set to the frequency of the radiated spurious emission of interest
2. Span was set greater than 1MHz
3. RBW = 200Hz for 9kHz to 150kHz frequency; RBW = 9kHz for 0.15MHz to 30MHz frequency
4. Detector = CISPR quasi-peak or power average (Average)
5. Sweep time = auto couple
6. Trace was allowed to stabilize

7.7.4. Test Setup

9kHz ~ 30MHz Test Setup:

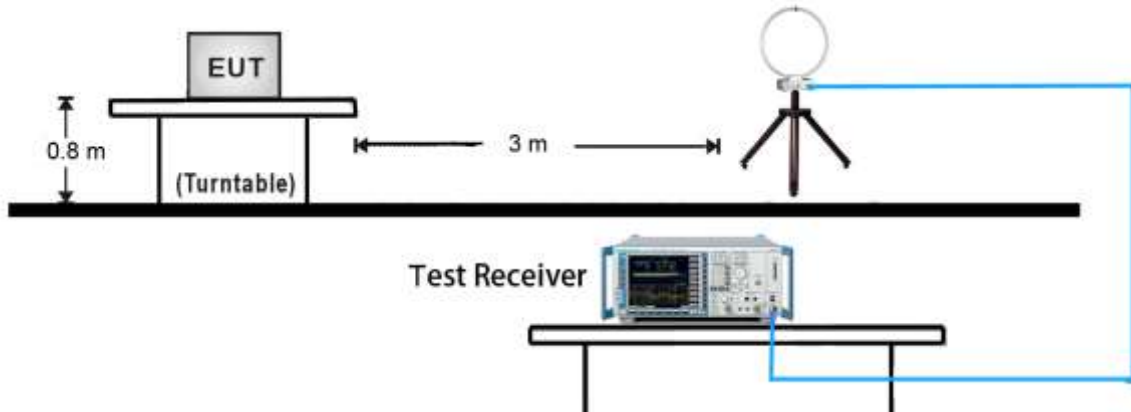

30MHz ~ 1GHz Test Setup:

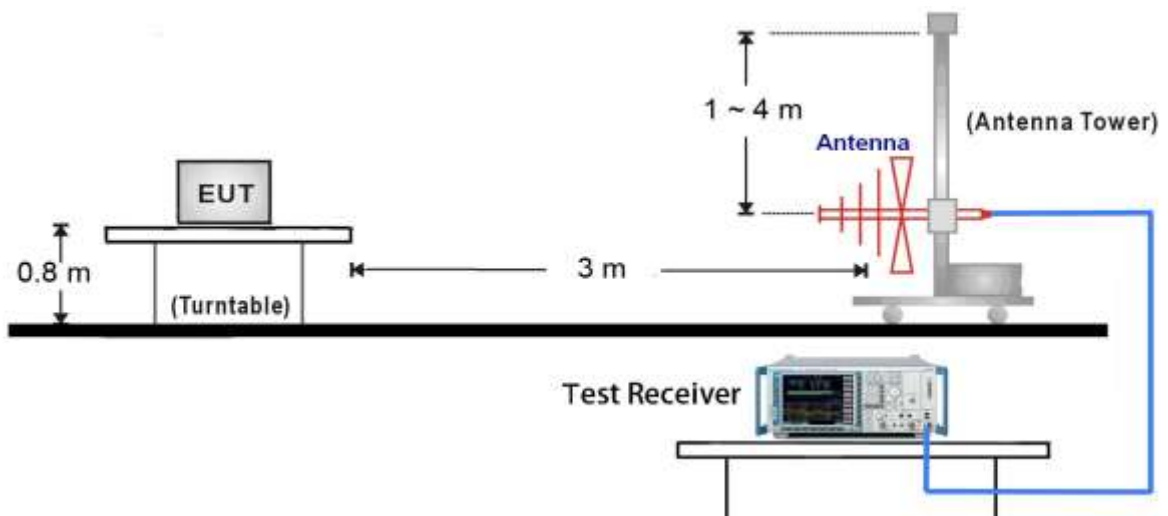

1GHz ~18GHz Test Setup:

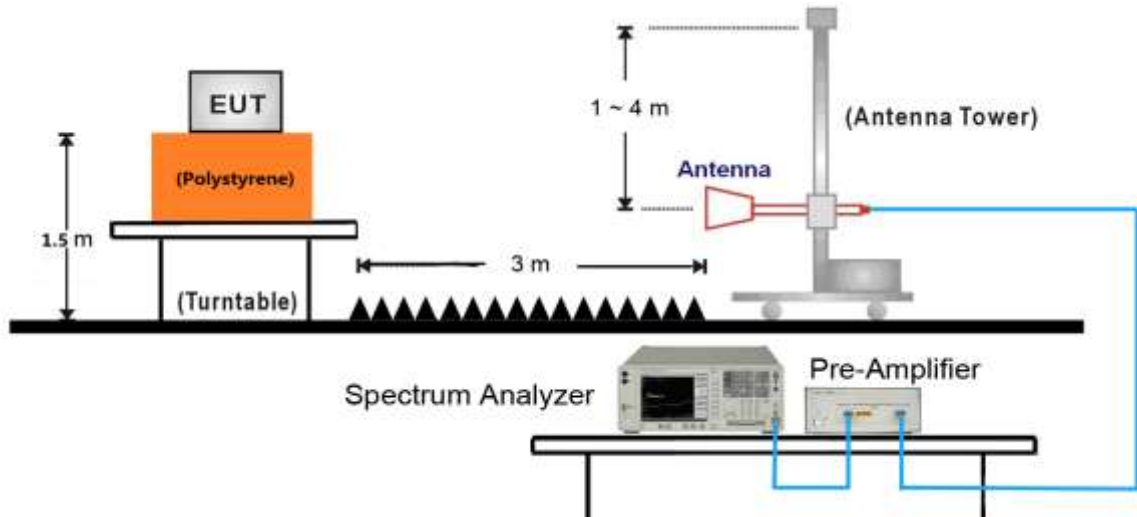

18GHz ~40GHz Test Setup:

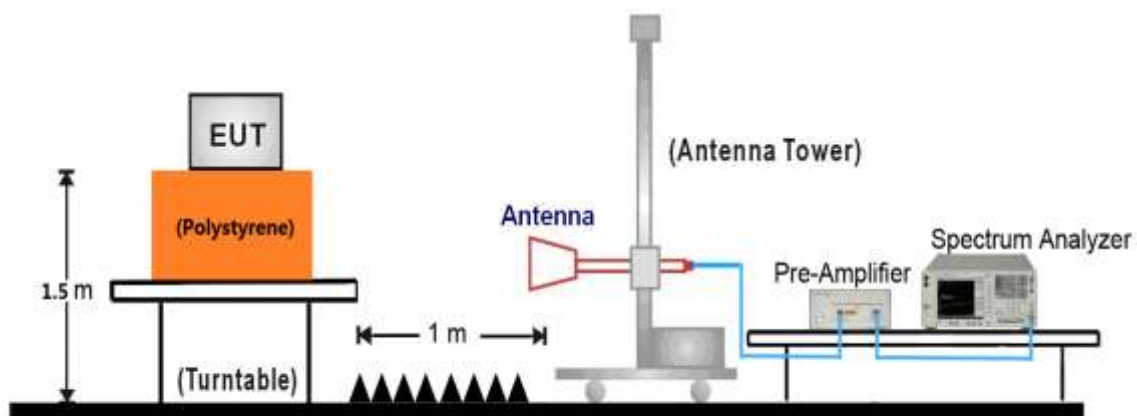

7.7.5. Test Result

EUT	WIFI USB DONGLE	Test Date	2017/12/18
Factor	VULB 9162 (30MHz~8GHz)	Temp. / Humidity	25°C / 60%
Polarity	Horizontal	Site / Engineer	AC1 / Peter
Test Mode	MODE2_CH44	Test Voltage	AC 120V/60Hz

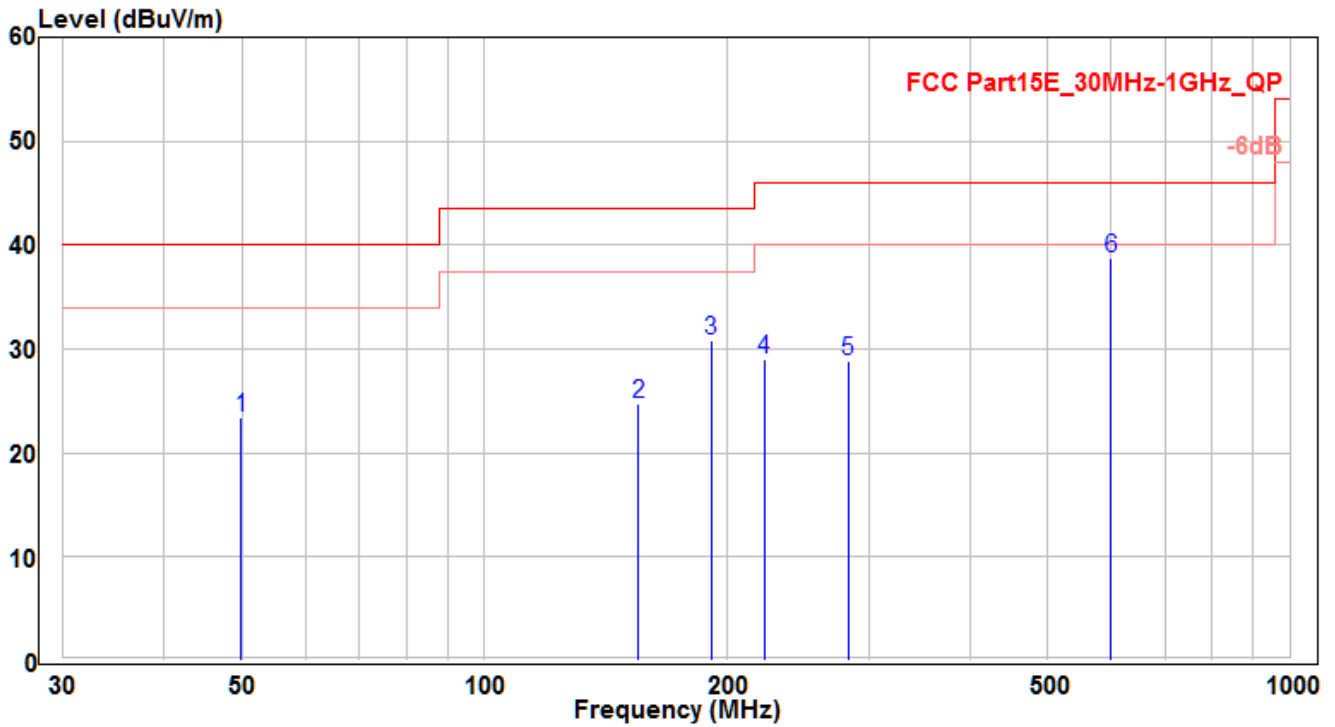

No	Frequency (MHz)	Reading (dBuV)	C.F (dB)	Measurement (dBuV/m)	Margin (dB)	Limit (dBuV/m)	Height (cm)	Angle (deg)	Remark (QP/PK/AV)
1	49.885	1.83	21.55	23.38	-16.62	40	100	40	QP
2	155.312	8.71	16.06	24.77	-18.73	43.5	100	360	QP
3	191.384	12.03	18.86	30.89	-12.61	43.5	100	35	QP
4	222.697	9.77	19.27	29.04	-16.96	46	100	360	QP
5	282.746	7.76	21.09	28.85	-17.15	46	100	50	QP
6	* 599.269	11.02	27.69	38.71	-7.29	46	100	160	QP

Note : The EUT Power by Notebook PC

1. " * " means this data is the worst emission level.
2. C.F (Correction Factor) = Antenna Factor (dB)+ Cable Loss (dB).
3. Measurement (dBuV/m) = Reading(dBuV) + C.F (Correction Factor).
4. Other channel/mode was also verified. The test results shown represent the worst case emissions °
5. No emission found between lowest internal used/generated frequency to 30MHz °

EUT	WIFI USB DONGLE	Test Date	2017/12/18
Factor	VULB 9162 (30MHz~8GHz)	Temp. / Humidity	25°C / 60%
Polarity	Vertical	Site / Engineer	AC1 / Peter
Test Mode	MODE2_CH44	Test Voltage	AC 120V/60Hz

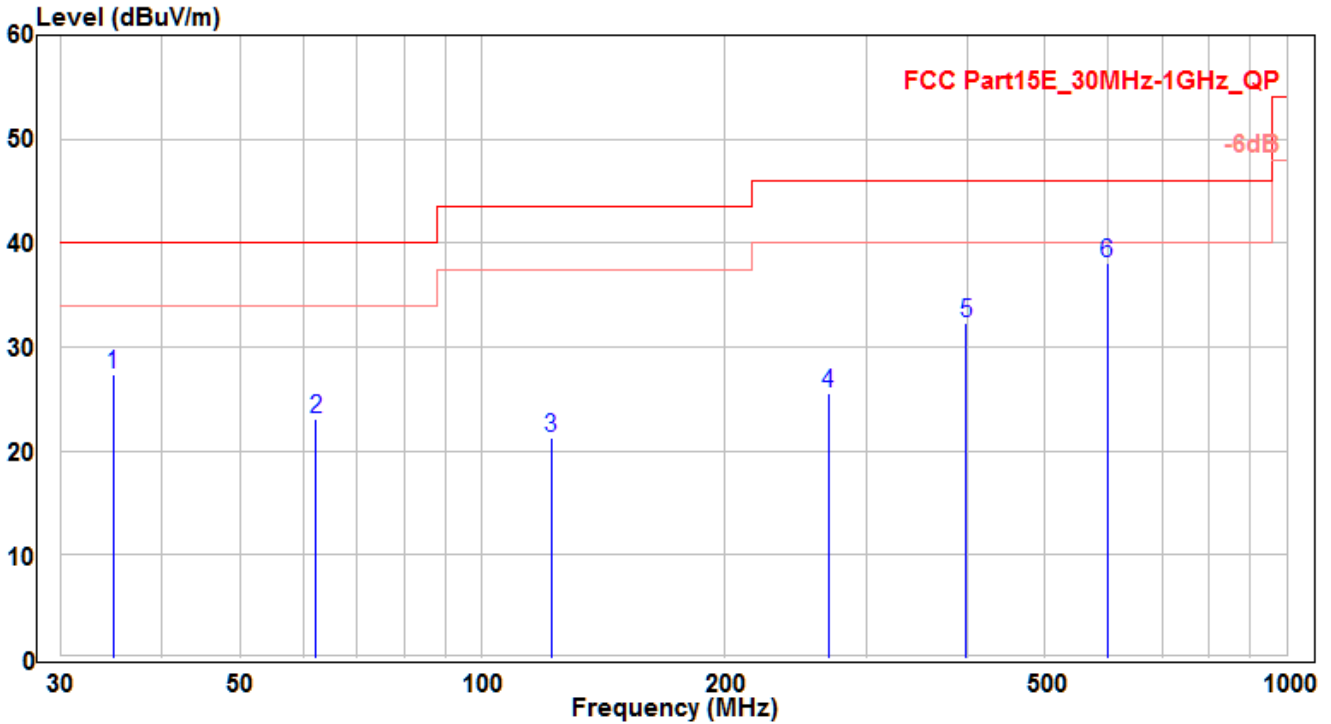

No	Frequency (MHz)	Reading (dBuV)	C.F (dB)	Measurement (dBuV/m)	Margin (dB)	Limit (dBuV/m)	Height (cm)	Angle (deg)	Remark (QP/PK/AV)
1	34.82	8.44	18.88	27.32	-12.68	40	100	400	QP
2	62.192	3.97	19.07	23.04	-16.96	40	100	60	QP
3	121.998	4.28	16.97	21.25	-22.25	43.5	100	190	QP
4	269.135	4.85	20.69	25.54	-20.46	46	100	40	QP
5	399.813	8.08	24.16	32.24	-13.76	46	100	40	QP
6	* 598.481	10.44	27.68	38.12	-7.88	46	100	310	QP

Note : The EUT Power by Notebook PC

1. " * " means this data is the worst emission level.
2. C.F (Correction Factor) = Antenna Factor (dB)+ Cable Loss (dB).
3. Measurement (dBuV/m) = Reading(dBuV) + C.F (Correction Factor).
4. Other channel/mode was also verified. The test results shown represent the worst case emissions ◦
5. No emission found between lowest internal used/generated frequency to 30MHz ◦

EUT	WIFI USB DONGLE	Test Date	2017/12/25
Factor	BBHA 9120D (1GHz~18GHz)	Temp. / Humidity	25°C / 60%
Polarity	Horizontal	Site / Engineer	AC1 / Peter
Test Mode	MODE1 -CH36	Test Voltage	AC 120V/60Hz

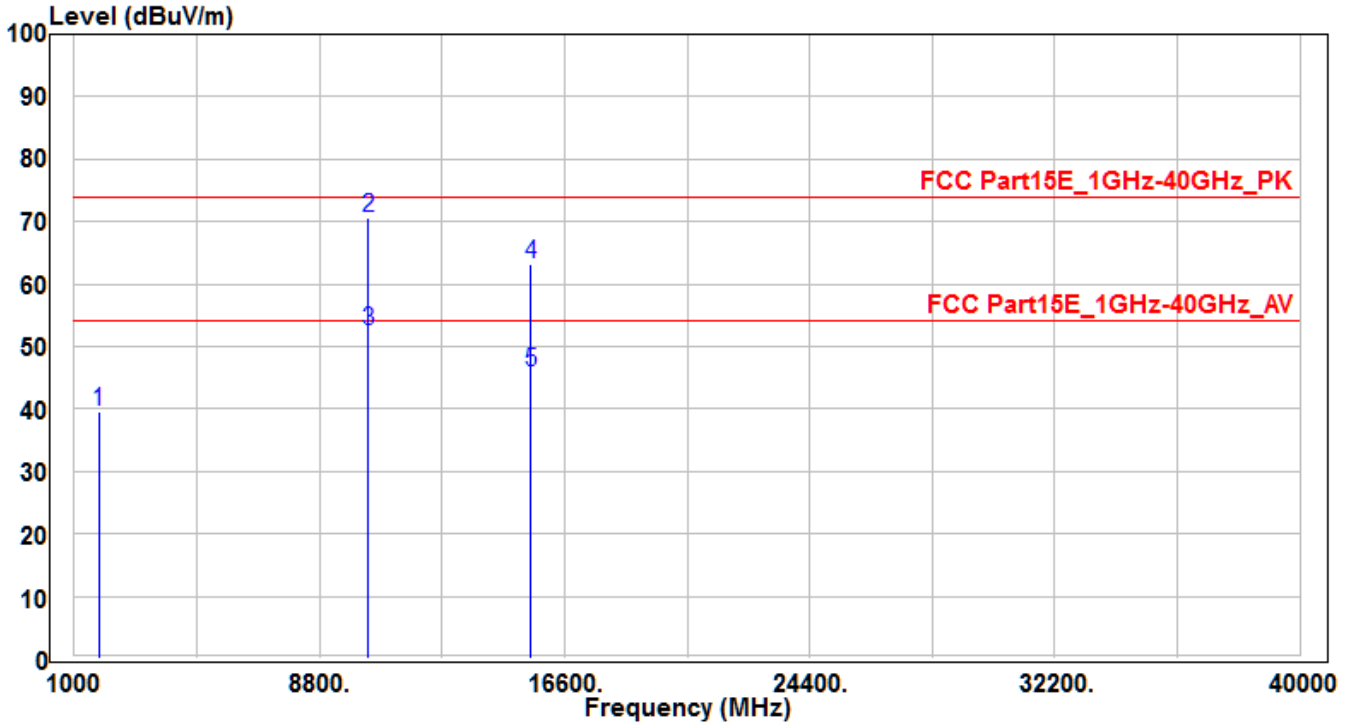

No	Frequency (MHz)	Reading (dBuV)	C.F (dB)	Measurement (dBuV/m)	Margin (dB)	Limit (dBuV/m)	Height (cm)	Angle (deg)	Remark (QP/PK/AV)
1	1792.55	44.96	-5.33	39.63	-34.37	74	150	400	Peak
2	* 10360	53.81	16.73	70.54	-3.46	74	165	320	Peak
3	* 10360	35.85	16.73	52.58	-1.42	54	165	320	Average
4	15540	42.19	21.01	63.2	-10.8	74	150	370	Peak
5	15540	24.9	21.01	45.91	-8.09	54	150	370	Average

Note : The EUT Power by Notebook PC

- " * " means this data is the worst emission level.
- .C.F (Correction Factor) = Antenna Factor (dB)+ Cable Loss (dB) – Preamplifier(dB).
- Measurement (dBuV/m) = Reading(dBuV) + C.F (Correction Factor).

EUT	WIFI USB DONGLE	Test Date	2017/12/25
Factor	BBHA 9120D (1GHz~18GHz)	Temp. / Humidity	25°C / 60%
Polarity	Vertical	Site / Engineer	AC1 / Peter
Test Mode	MODE1 -CH36	Test Voltage	AC 120V/60Hz

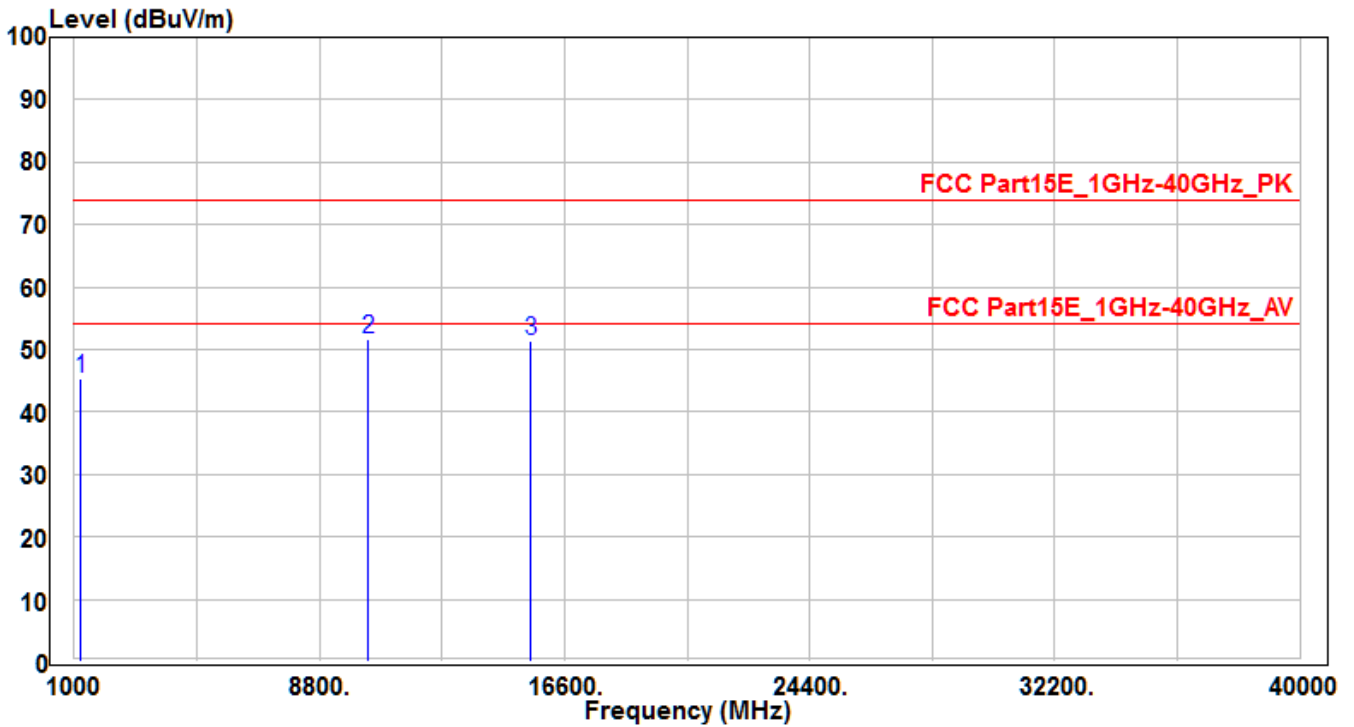

No	Frequency (MHz)	Reading (dBuV)	C.F (dB)	Measurement (dBuV/m)	Margin (dB)	Limit (dBuV/m)	Height (cm)	Angle (deg)	Remark (QP/PK/AV)
1	1199.776	52.33	-7.06	45.27	-28.73	74	150	400	Peak
2	* 10360	35.01	16.73	51.74	-22.26	74	150	400	Peak
3	15540	30.34	21.01	51.35	-22.65	74	150	400	Peak

Note : The EUT Power by Notebook PC

- " * " means this data is the worst emission level.
- .C.F (Correction Factor) = Antenna Factor (dB)+ Cable Loss (dB) – Preamplifier(dB).
- Measurement (dBuV/m) = Reading(dBuV) + C.F (Correction Factor).

EUT	WIFI USB DONGLE	Test Date	2017/12/25
Factor	BBHA 9120D (1GHz~18GHz)	Temp. / Humidity	25°C / 60%
Polarity	Horizontal	Site / Engineer	AC1 / Peter
Test Mode	MODE1 -CH44	Test Voltage	AC 120V/60Hz

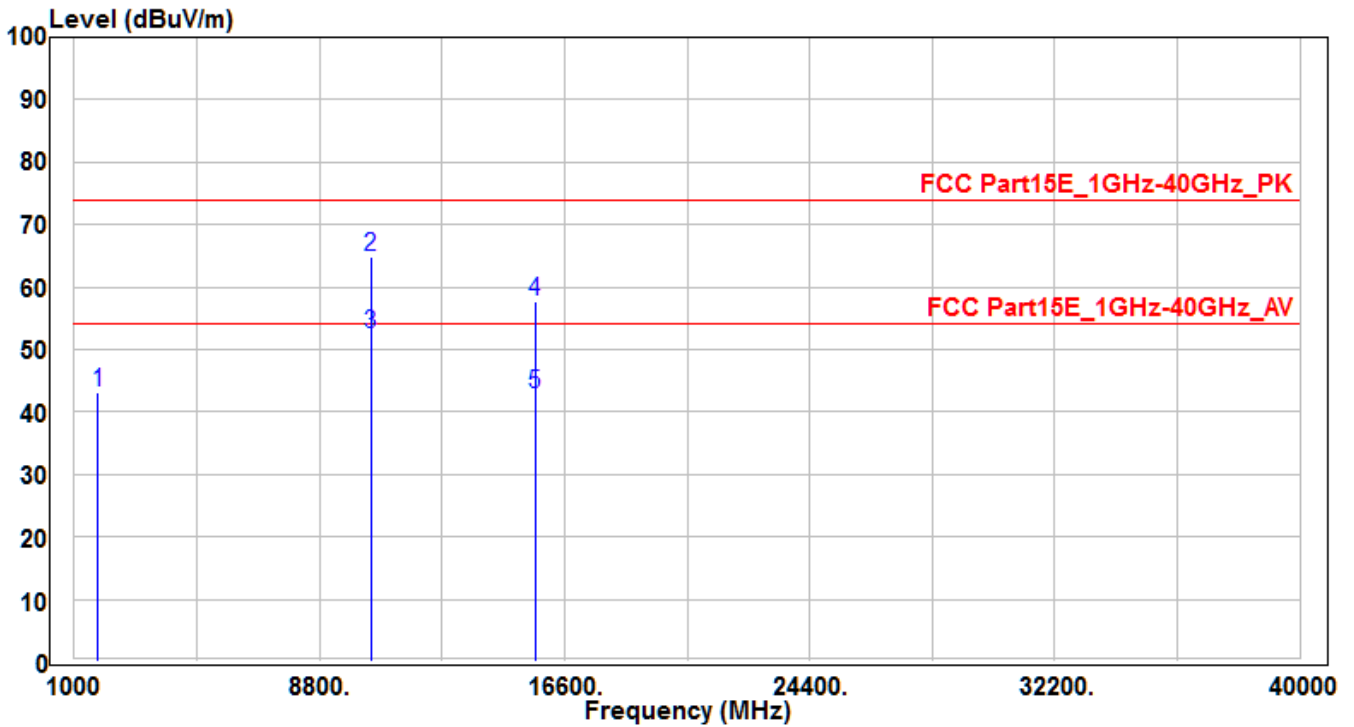

No	Frequency (MHz)	Reading (dBuV)	C.F (dB)	Measurement (dBuV/m)	Margin (dB)	Limit (dBuV/m)	Height (cm)	Angle (deg)	Remark (QP/PK/AV)
1	1754.25	48.52	-5.46	43.06	-30.94	74	150	400	Peak
2	*	10440	17.04	64.93	-9.07	74	195	400	Peak
3	*	10440	17.04	52.48	-1.52	54	195	400	Average
4		15660	20.84	57.76	-16.24	74	150	400	Peak
5		15660	20.84	42.89	-11.11	54	150	400	Average

Note : The EUT Power by Notebook PC

- " * " means this data is the worst emission level.
- .C.F (Correction Factor) = Antenna Factor (dB)+ Cable Loss (dB) – Preamplifier(dB).
- Measurement (dBuV/m) = Reading(dBuV) + C.F (Correction Factor).

EUT	WIFI USB DONGLE	Test Date	2017/12/25
Factor	BBHA 9120D (1GHz~18GHz)	Temp. / Humidity	25°C / 60%
Polarity	Vertical	Site / Engineer	AC1 / Peter
Test Mode	MODE1 -CH44	Test Voltage	AC 120V/60Hz

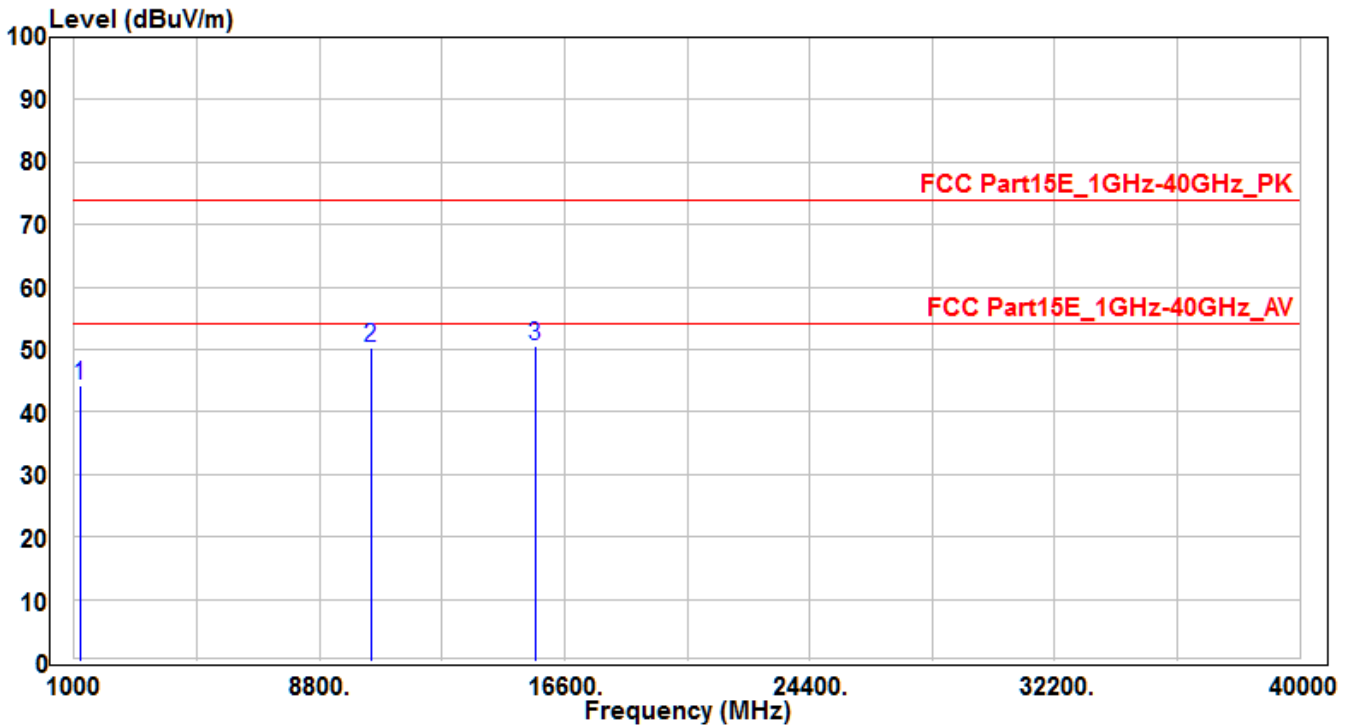

No	Frequency (MHz)	Reading (dBuV)	C.F (dB)	Measurement (dBuV/m)	Margin (dB)	Limit (dBuV/m)	Height (cm)	Angle (deg)	Remark (QP/PK/AV)
1	1195.65	51.2	-7.07	44.13	-29.87	74	150	400	Peak
2	10440	33.3	17.04	50.34	-23.66	74	150	400	Peak
3	* 15660	29.76	20.84	50.6	-23.4	74	150	400	Peak

Note : The EUT Power by Notebook PC

1. " * " means this data is the worst emission level.
2. .C.F (Correction Factor) = Antenna Factor (dB)+ Cable Loss (dB) – Preamplifier(dB).
3. Measurement (dBuV/m) = Reading(dBuV) + C.F (Correction Factor).

EUT	WIFI USB DONGLE	Test Date	2017/12/25
Factor	BBHA 9120D (1GHz~18GHz)	Temp. / Humidity	25°C / 60%
Polarity	Horizontal	Site / Engineer	AC1 / Peter
Test Mode	MODE1 -CH48	Test Voltage	AC 120V/60Hz

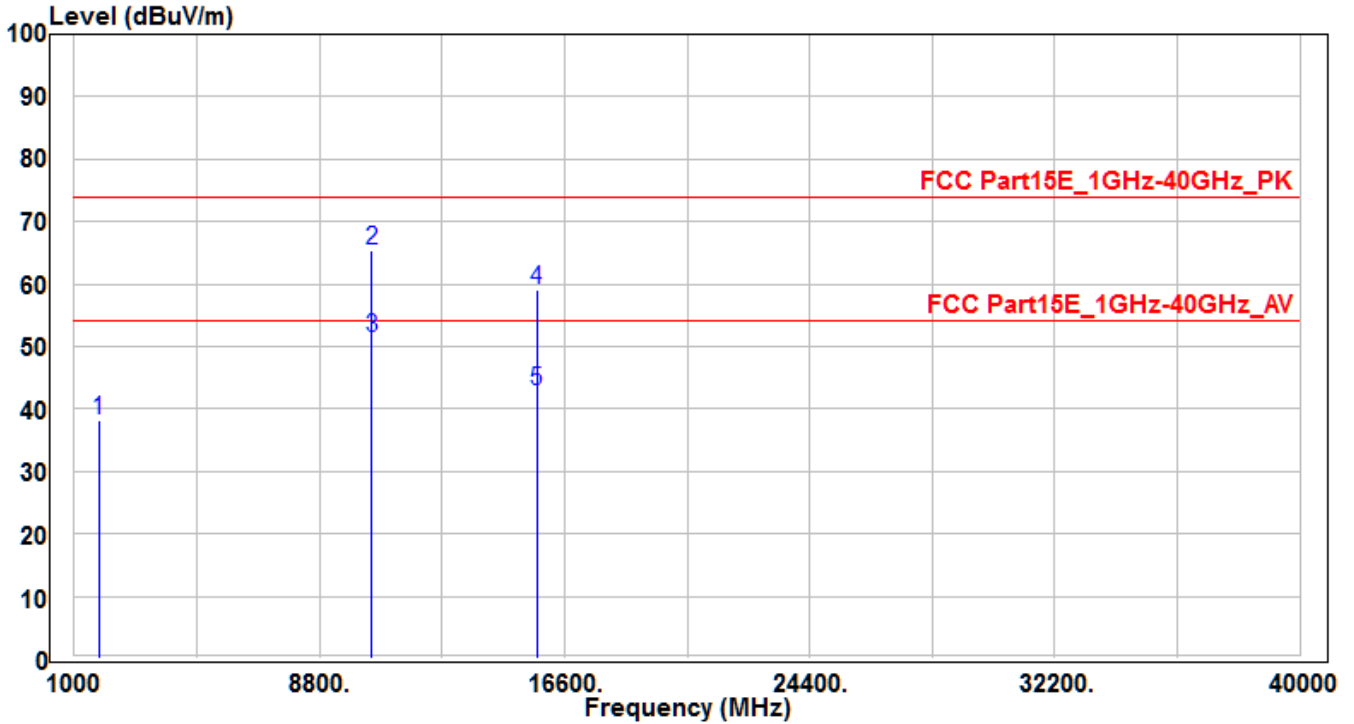

No	Frequency (MHz)	Reading (dBuV)	C.F (dB)	Measurement (dBuV/m)	Margin (dB)	Limit (dBuV/m)	Height (cm)	Angle (deg)	Remark (QP/PK/AV)
1	1786.62	43.52	-5.35	38.17	-35.83	74	150	400	Peak
2	* 10480	48.23	17.2	65.43	-8.57	74	150	380	Peak
3	* 10480	34.19	17.2	51.39	-2.61	54	150	380	Average
4	15720	38.28	20.77	59.05	-14.95	74	165	400	Peak
5	15720	22	20.77	42.77	-11.23	54	165	400	Average

Note : The EUT Power by Notebook PC

- " * " means this data is the worst emission level.
- .C.F (Correction Factor) = Antenna Factor (dB)+ Cable Loss (dB) – Preamplifier(dB).
- Measurement (dBuV/m) = Reading(dBuV) + C.F (Correction Factor).

EUT	WIFI USB DONGLE	Test Date	2017/12/25
Factor	BBHA 9120D (1GHz~18GHz)	Temp. / Humidity	25°C / 60%
Polarity	Vertical	Site / Engineer	AC1 / Peter
Test Mode	MODE1 -CH48	Test Voltage	AC 120V/60Hz

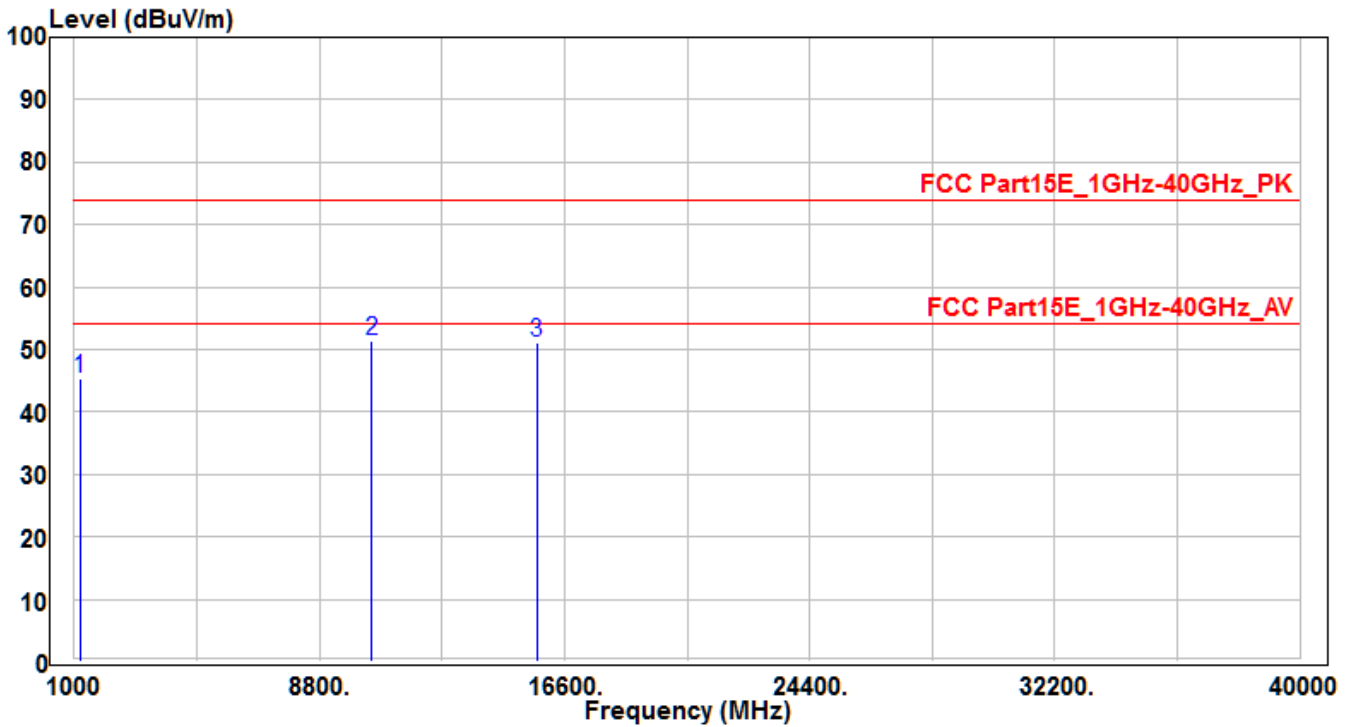

No	Frequency (MHz)	Reading (dBuV)	C.F (dB)	Measurement (dBuV/m)	Margin (dB)	Limit (dBuV/m)	Height (cm)	Angle (deg)	Remark (QP/PK/AV)
1	1186	52.32	-7.1	45.22	-28.78	74	150	400	Peak
2	* 10480	34.06	17.2	51.26	-22.74	74	150	400	Peak
3	15720	30.24	20.77	51.01	-22.99	74	150	400	Peak

Note : The EUT Power by Notebook PC

- "*" means this data is the worst emission level.
- .C.F (Correction Factor) = Antenna Factor (dB)+ Cable Loss (dB) – Preamplifier(dB).
- Measurement (dBuV/m) = Reading(dBuV) + C.F (Correction Factor).

EUT	WIFI USB DONGLE	Test Date	2017/12/25
Factor	BBHA 9120D (1GHz~18GHz)	Temp. / Humidity	25°C / 60%
Polarity	Horizontal	Site / Engineer	AC1 / Peter
Test Mode	MODE1 -CH149	Test Voltage	AC 120V/60Hz

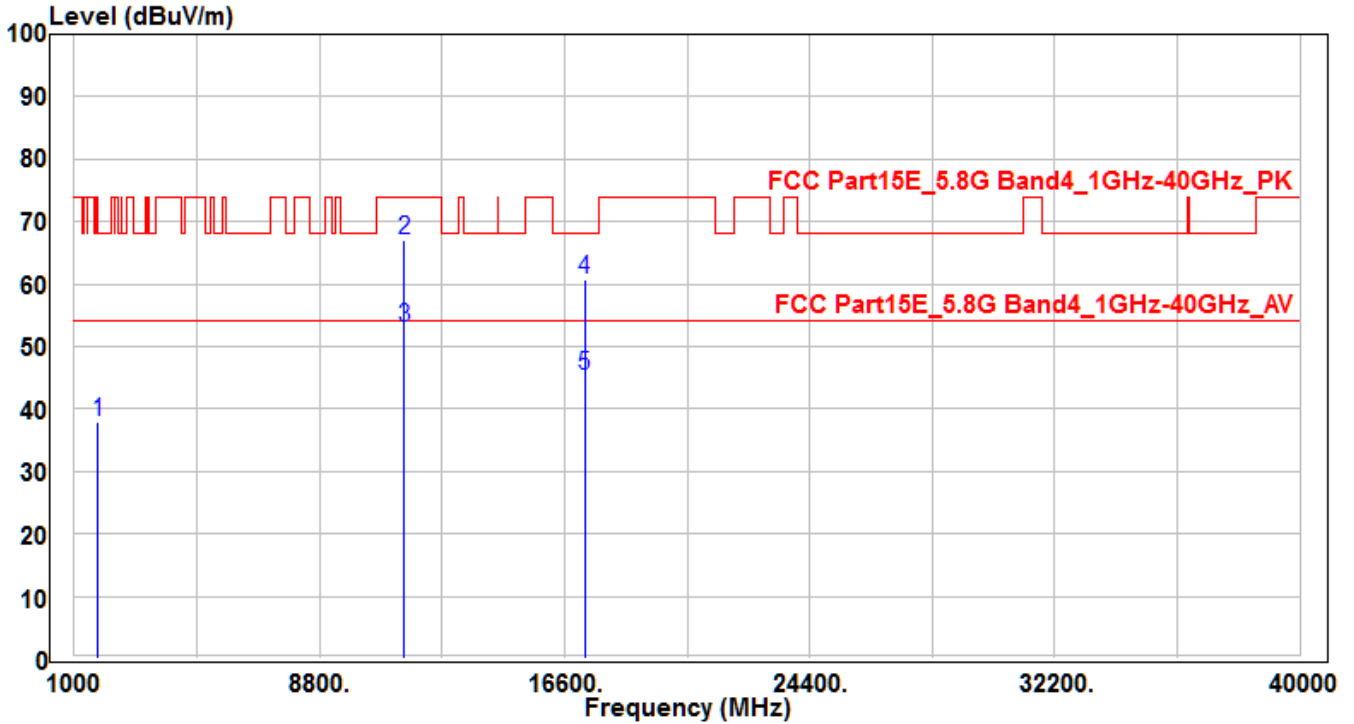

No	Frequency (MHz)	Reading (dBuV)	C.F (dB)	Measurement (dBuV/m)	Margin (dB)	Limit (dBuV/m)	Height (cm)	Angle (deg)	Remark (QP/PK/AV)	
1	1754.852	43.36	-5.46	37.9	-30.3	68.2	150	400	Peak	
2	*	11490	48.64	18.35	66.99	-7.01	74	195	-40	Peak
3	*	11490	34.56	18.35	52.91	-1.09	54	195	-40	Average
4	17235	33.65	26.96	60.61	-7.59	68.2	175	-40	Peak	
5	17235	18.28	26.96	45.24	-8.76	54	175	-40	Average	

Note : The EUT Power by Notebook PC

- " * " means this data is the worst emission level.
- .C.F (Correction Factor) = Antenna Factor (dB)+ Cable Loss (dB) – Preamplifier(dB).
- Measurement (dBuV/m) = Reading(dBuV) + C.F (Correction Factor).

EUT	WIFI USB DONGLE	Test Date	2017/12/25
Factor	BBHA 9120D (1GHz~18GHz)	Temp. / Humidity	25°C / 60%
Polarity	Vertical	Site / Engineer	AC1 / Peter
Test Mode	MODE1 -CH149	Test Voltage	AC 120V/60Hz

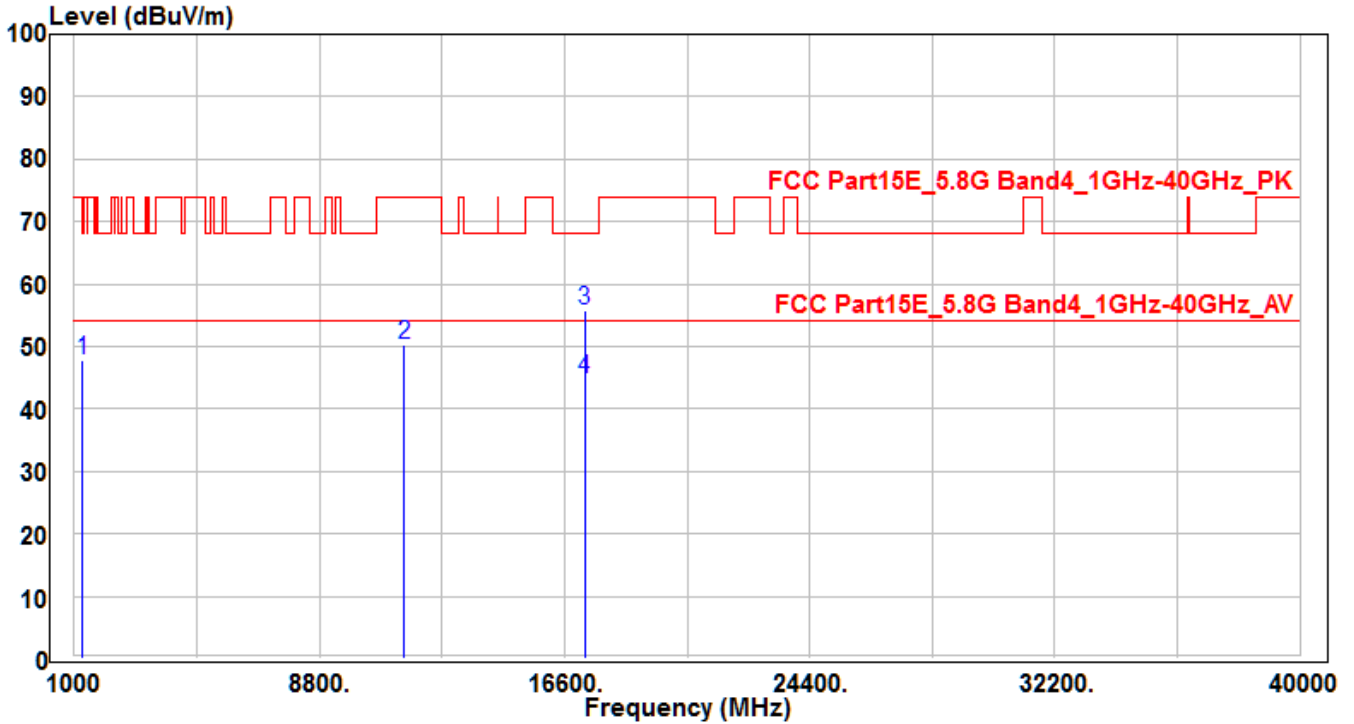

No	Frequency (MHz)	Reading (dBuV)	C.F (dB)	Measurement (dBuV/m)	Margin (dB)	Limit (dBuV/m)	Height (cm)	Angle (deg)	Remark (QP/PK/AV)
1	1254.2	54.74	-6.93	47.81	-20.39	68.2	150	400	Peak
2	11490	32.01	18.35	50.36	-23.64	74	150	400	Peak
3	17235	28.71	26.96	55.67	-12.53	68.2	225	400	Peak
4	* 17235	17.79	26.96	44.75	-9.25	54	225	400	Average

Note : The EUT Power by Notebook PC

1. " * " means this data is the worst emission level.
2. .C.F (Correction Factor) = Antenna Factor (dB)+ Cable Loss (dB) – Preamplifier(dB).
3. Measurement (dBuV/m) = Reading(dBuV) + C.F (Correction Factor).

EUT	WIFI USB DONGLE	Test Date	2017/12/25
Factor	BBHA 9120D (1GHz~18GHz)	Temp. / Humidity	25°C / 60%
Polarity	Horizontal	Site / Engineer	AC1 / Peter
Test Mode	MODE1 -CH157	Test Voltage	AC 120V/60Hz

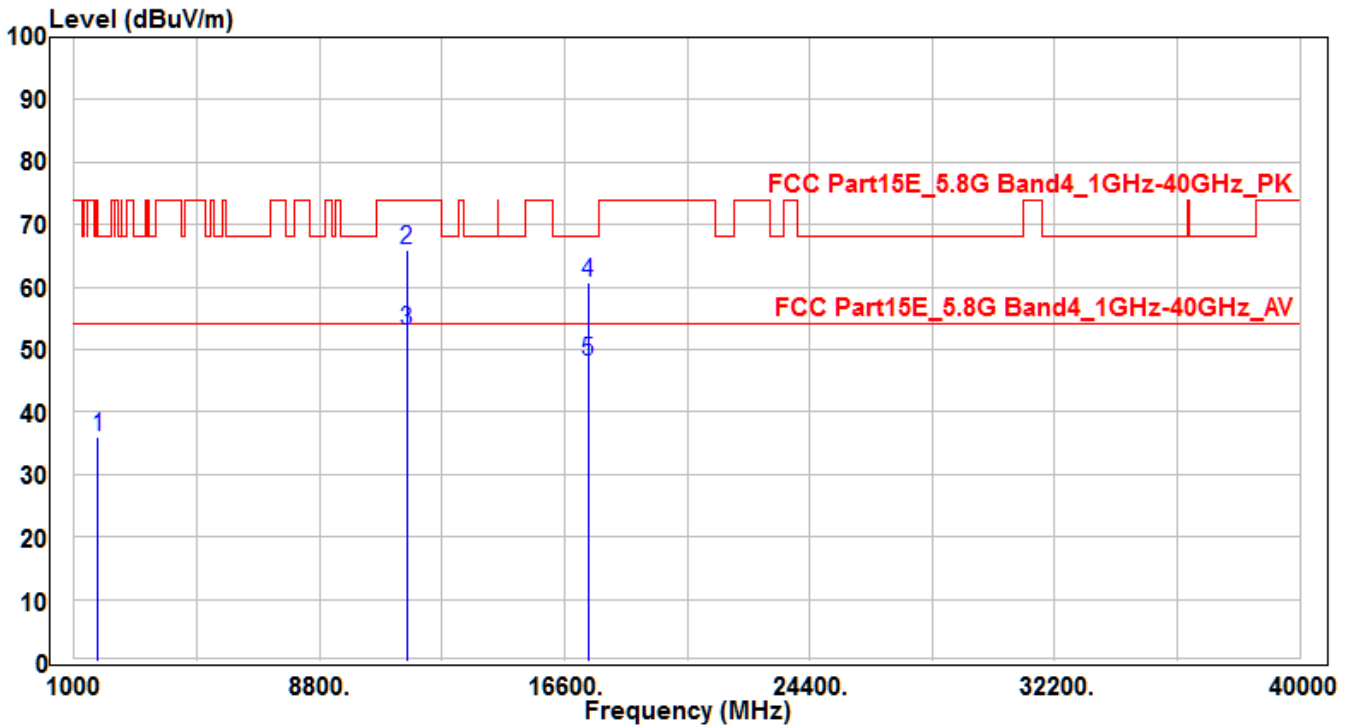

No	Frequency (MHz)	Reading (dBuV)	C.F (dB)	Measurement (dBuV/m)	Margin (dB)	Limit (dBuV/m)	Height (cm)	Angle (deg)	Remark (QP/PK/AV)	
1	1745.21	41.52	-5.49	36.03	-32.17	68.2	150	400	Peak	
2	*	11570	47.71	18.24	65.95	-8.05	74	170	35	Peak
3	*	11570	34.69	18.24	52.93	-1.07	54	170	35	Average
4	17355	32.83	27.81	60.64	-7.56	68.2	150	15	Peak	
5	17355	20.2	27.81	48.01	-5.99	54	150	15	Average	

Note : The EUT Power by Notebook PC

- "*" means this data is the worst emission level.
- .C.F (Correction Factor) = Antenna Factor (dB)+ Cable Loss (dB) – Preamplifier(dB).
- Measurement (dBuV/m) = Reading(dBuV) + C.F (Correction Factor).

EUT	WIFI USB DONGLE	Test Date	2017/12/25
Factor	BBHA 9120D (1GHz~18GHz)	Temp. / Humidity	25°C / 60%
Polarity	Vertical	Site / Engineer	AC1 / Peter
Test Mode	MODE1 -CH157	Test Voltage	AC 120V/60Hz

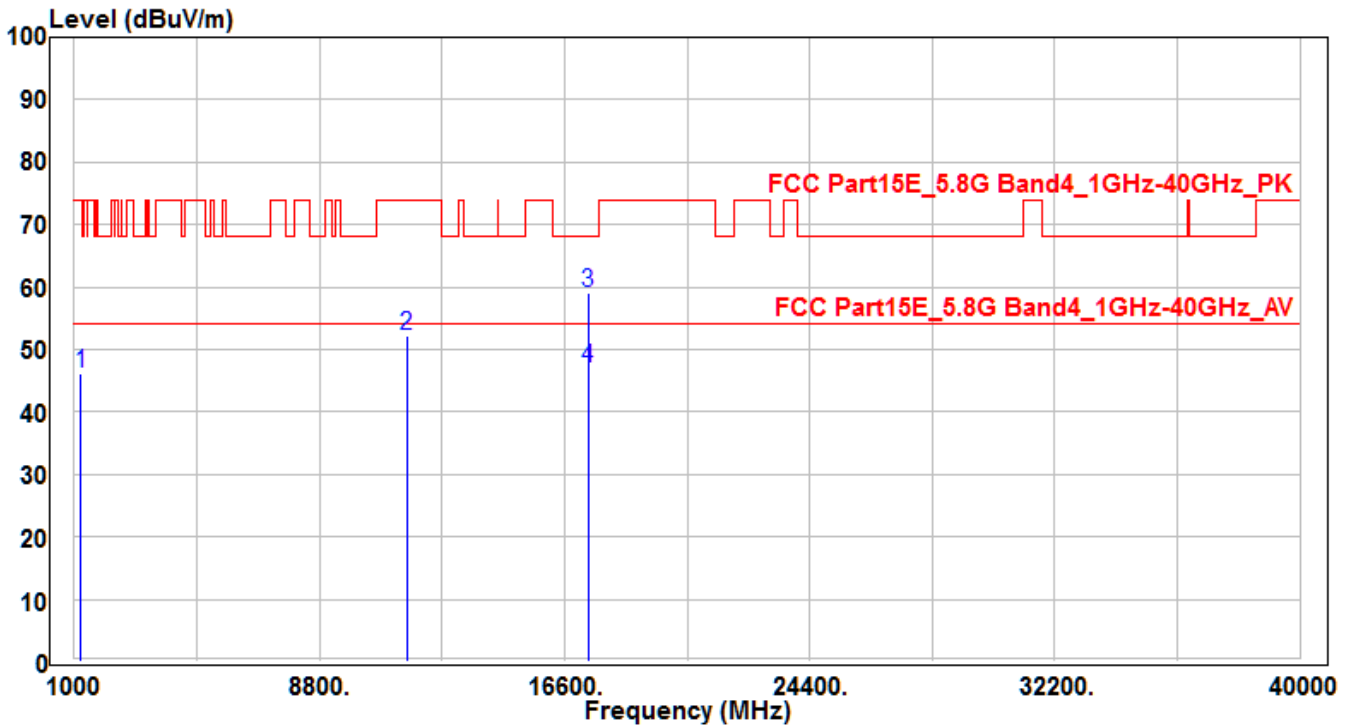

No	Frequency (MHz)	Reading (dBuV)	C.F (dB)	Measurement (dBuV/m)	Margin (dB)	Limit (dBuV/m)	Height (cm)	Angle (deg)	Remark (QP/PK/AV)
1	1200.3	53.2	-7.06	46.14	-27.86	74	150	400	Peak
2	11570	33.85	18.24	52.09	-21.91	74	150	400	Peak
3	*	31.3	27.81	59.11	-9.09	68.2	205	-15	Peak
4	*	19.12	27.81	46.93	-7.07	54	205	-15	Average

Note : The EUT Power by Notebook PC

1. " * " means this data is the worst emission level.
2. .C.F (Correction Factor) = Antenna Factor (dB)+ Cable Loss (dB) – Preamplifier(dB).
3. Measurement (dBuV/m) = Reading(dBuV) + C.F (Correction Factor).

EUT	WIFI USB DONGLE	Test Date	2017/12/25
Factor	BBHA 9120D (1GHz~18GHz)	Temp. / Humidity	25°C / 60%
Polarity	Horizontal	Site / Engineer	AC1 / Peter
Test Mode	MODE1 -CH165	Test Voltage	AC 120V/60Hz

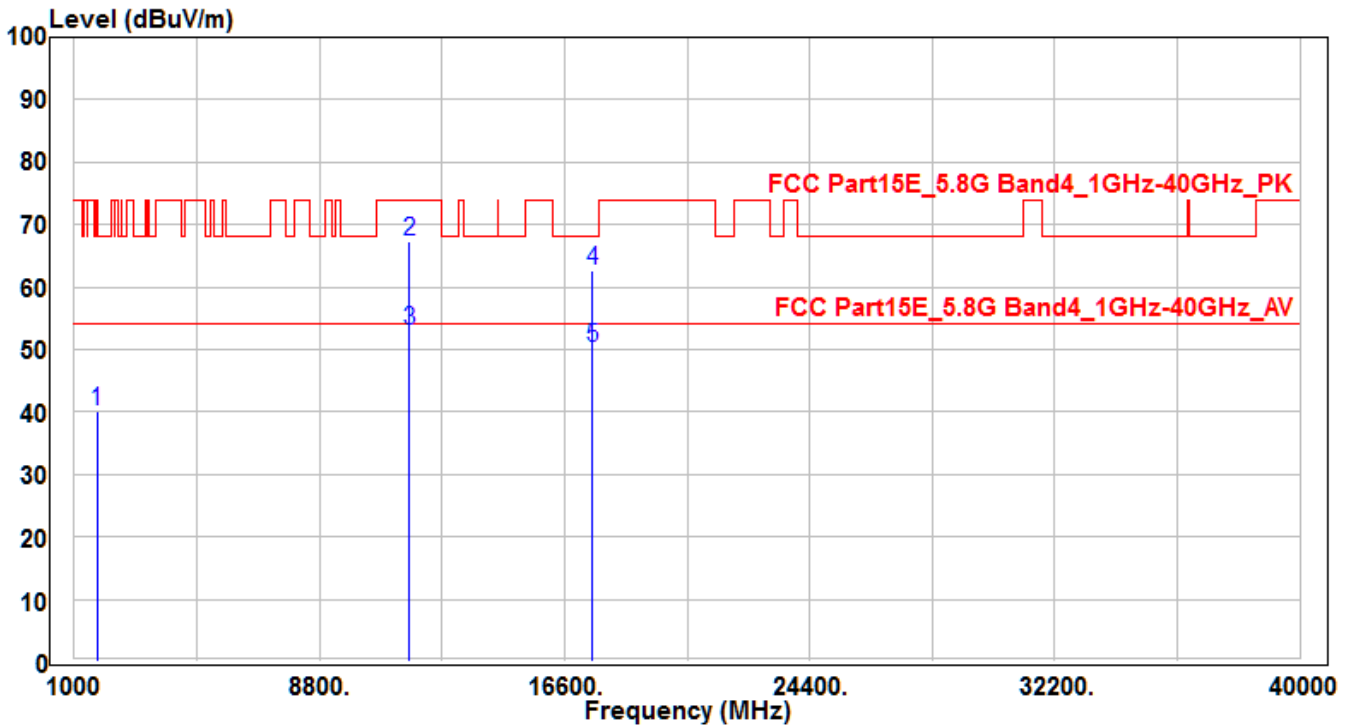

No	Frequency (MHz)	Reading (dBuV)	C.F (dB)	Measurement (dBuV/m)	Margin (dB)	Limit (dBuV/m)	Height (cm)	Angle (deg)	Remark (QP/PK/AV)
1	1721.21	45.62	-5.57	40.05	-33.95	74	150	400	Peak
2	* 11650	49.29	18.1	67.39	-6.61	74	170	380	Peak
3	* 11650	34.96	18.1	53.06	-0.94	54	170	380	Average
4	17475	34.03	28.66	62.69	-5.51	68.2	150	395	Peak
5	17475	21.65	28.66	50.31	-3.69	54	150	395	Average

Note : The EUT Power by Notebook PC

- " * " means this data is the worst emission level.
- .C.F (Correction Factor) = Antenna Factor (dB)+ Cable Loss (dB) – Preamplifier(dB).
- Measurement (dBuV/m) = Reading(dBuV) + C.F (Correction Factor).

EUT	WIFI USB DONGLE	Test Date	2017/12/25
Factor	BBHA 9120D (1GHz~18GHz)	Temp. / Humidity	25°C / 60%
Polarity	Vertical	Site / Engineer	AC1 / Peter
Test Mode	MODE1 -CH165	Test Voltage	AC 120V/60Hz

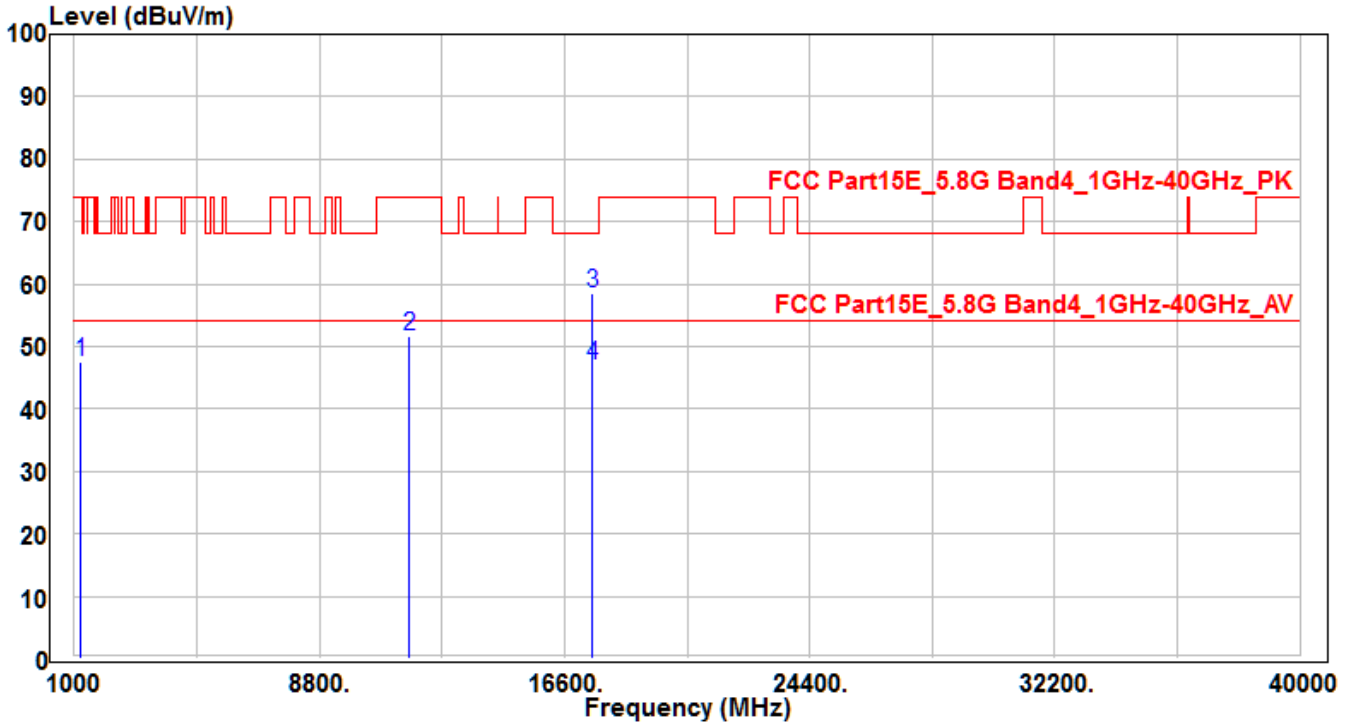

No	Frequency (MHz)	Reading (dBuV)	C.F (dB)	Measurement (dBuV/m)	Margin (dB)	Limit (dBuV/m)	Height (cm)	Angle (deg)	Remark (QP/PK/AV)
1	1199.56	54.52	-7.06	47.46	-26.54	74	150	400	Peak
2	11650	33.67	18.1	51.77	-22.23	74	150	400	Peak
3	* 17475	29.92	28.66	58.58	-9.62	68.2	150	350	Peak
4	* 17475	18.27	28.66	46.93	-7.07	54	150	350	Average

Note : The EUT Power by Notebook PC

1. " * " means this data is the worst emission level.
2. .C.F (Correction Factor) = Antenna Factor (dB)+ Cable Loss (dB) – Preamplifier(dB).
3. Measurement (dBuV/m) = Reading(dBuV) + C.F (Correction Factor).

EUT	WIFI USB DONGLE	Test Date	2017/12/25
Factor	BBHA 9120D (1GHz~18GHz)	Temp. / Humidity	25°C / 60%
Polarity	Horizontal	Site / Engineer	AC1 / Peter
Test Mode	MODE2 -CH36	Test Voltage	AC 120V/60Hz

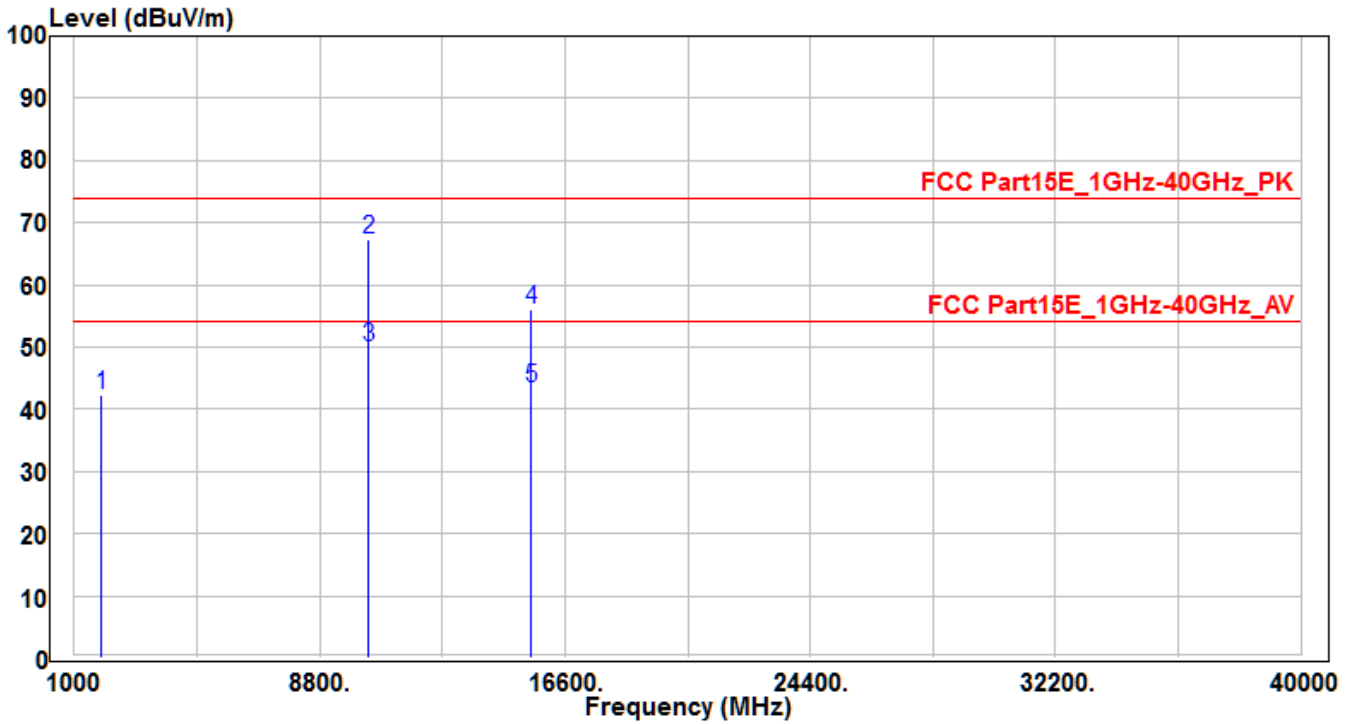

No	Frequency (MHz)	Reading (dBuV)	C.F (dB)	Measurement (dBuV/m)	Margin (dB)	Limit (dBuV/m)	Height (cm)	Angle (deg)	Remark (QP/PK/AV)
1	1852.63	47.52	-5.12	42.4	-31.6	74	150	400	Peak
2	* 10360	50.46	16.73	67.19	-6.81	74	150	365	Peak
3	* 10360	33.4	16.73	50.13	-3.87	54	150	365	Average
4	15540	35.04	21.01	56.05	-17.95	74	165	400	Peak
5	15540	22.34	21.01	43.35	-10.65	54	165	400	Average

Note : The EUT Power by Notebook PC

- " * " means this data is the worst emission level.
- .C.F (Correction Factor) = Antenna Factor (dB)+ Cable Loss (dB) – Preamplifier(dB).
- Measurement (dBuV/m) = Reading(dBuV) + C.F (Correction Factor).

EUT	WIFI USB DONGLE	Test Date	2017/12/25
Factor	BBHA 9120D (1GHz~18GHz)	Temp. / Humidity	25°C / 60%
Polarity	Vertical	Site / Engineer	AC1 / Peter
Test Mode	MODE2 -CH36	Test Voltage	AC 120V/60Hz

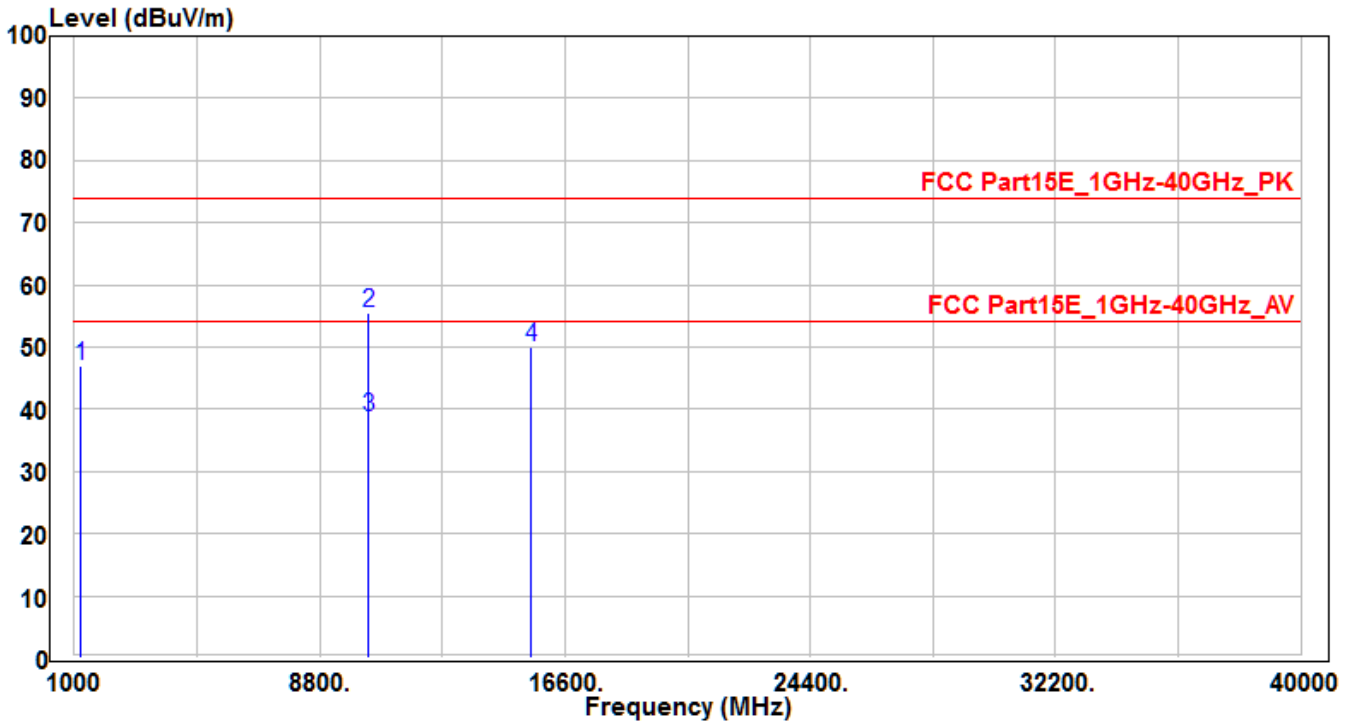

No	Frequency (MHz)	Reading (dBUV)	C.F (dB)	Measurement (dBUV/m)	Margin (dB)	Limit (dBUV/m)	Height (cm)	Angle (deg)	Remark (QP/PK/AV)
1	1205.2	54.12	-7.05	47.07	-26.93	74	150	400	Peak
2	* 10360	38.88	16.73	55.61	-18.39	74	150	35	Peak
3	* 10360	22.1	16.73	38.83	-15.17	54	150	35	Average
4	15540	28.9	21.01	49.91	-24.09	74	150	400	Peak

Note : The EUT Power by Notebook PC

1. " * " means this data is the worst emission level.
2. .C.F (Correction Factor) = Antenna Factor (dB)+ Cable Loss (dB) – Preamplifier(dB).
3. Measurement (dBUV/m) = Reading(dBUV) + C.F (Correction Factor).

EUT	WIFI USB DONGLE	Test Date	2017/12/25
Factor	BBHA 9120D (1GHz~18GHz)	Temp. / Humidity	25°C / 60%
Polarity	Horizontal	Site / Engineer	AC1 / Peter
Test Mode	MODE2 -CH44	Test Voltage	AC 120V/60Hz

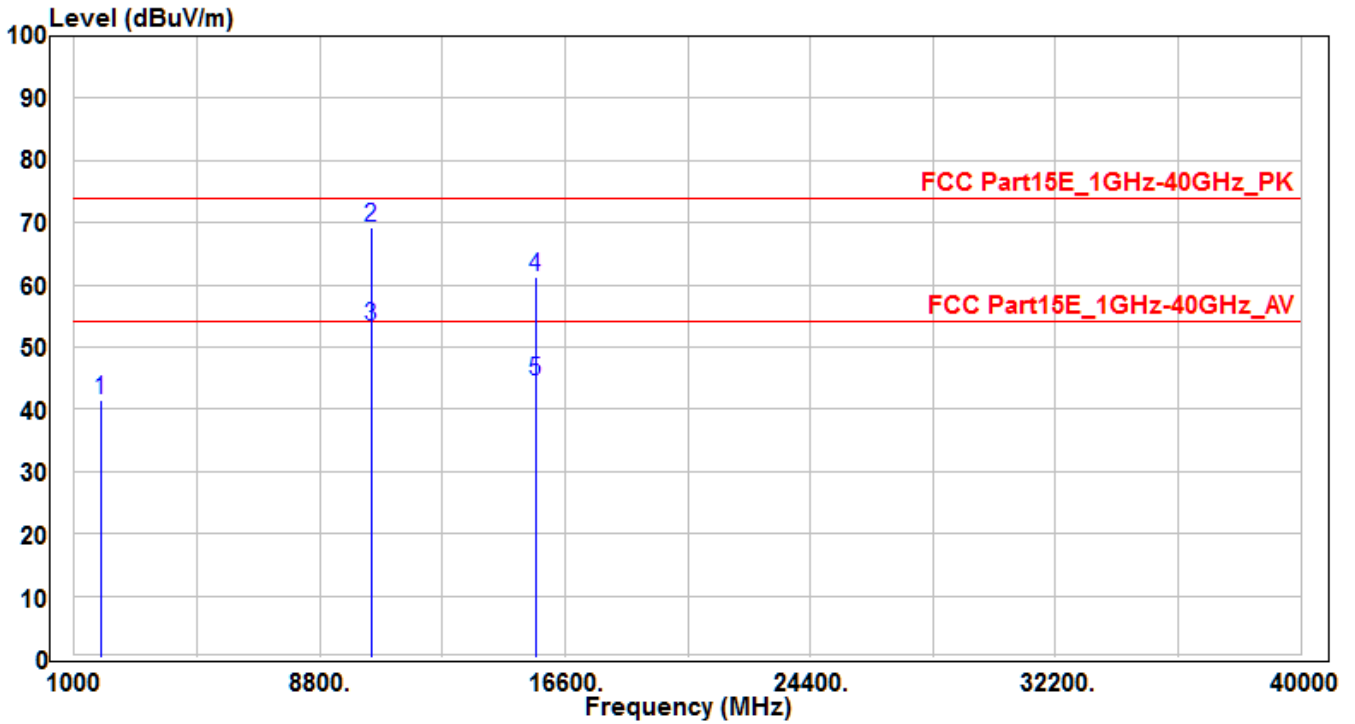

No	Frequency (MHz)	Reading (dBuV)	C.F (dB)	Measurement (dBuV/m)	Margin (dB)	Limit (dBuV/m)	Height (cm)	Angle (deg)	Remark (QP/PK/AV)
1	1841.51	46.53	-5.16	41.37	-32.63	74	150	400	Peak
2	* 10440	52.3	17.04	69.34	-4.66	74	160	-30	Peak
3	* 10440	36.23	17.04	53.27	-0.73	54	160	-30	Average
4	15660	40.33	20.84	61.17	-12.83	74	165	10	Peak
5	15660	23.72	20.84	44.56	-9.44	54	165	10	Average

Note : The EUT Power by Notebook PC

- " * " means this data is the worst emission level.
- .C.F (Correction Factor) = Antenna Factor (dB)+ Cable Loss (dB) – Preamplifier(dB).
- Measurement (dBuV/m) = Reading(dBuV) + C.F (Correction Factor).

EUT	WIFI USB DONGLE	Test Date	2017/12/25
Factor	BBHA 9120D (1GHz~18GHz)	Temp. / Humidity	25°C / 60%
Polarity	Vertical	Site / Engineer	AC1 / Peter
Test Mode	MODE2 -CH44	Test Voltage	AC 120V/60Hz

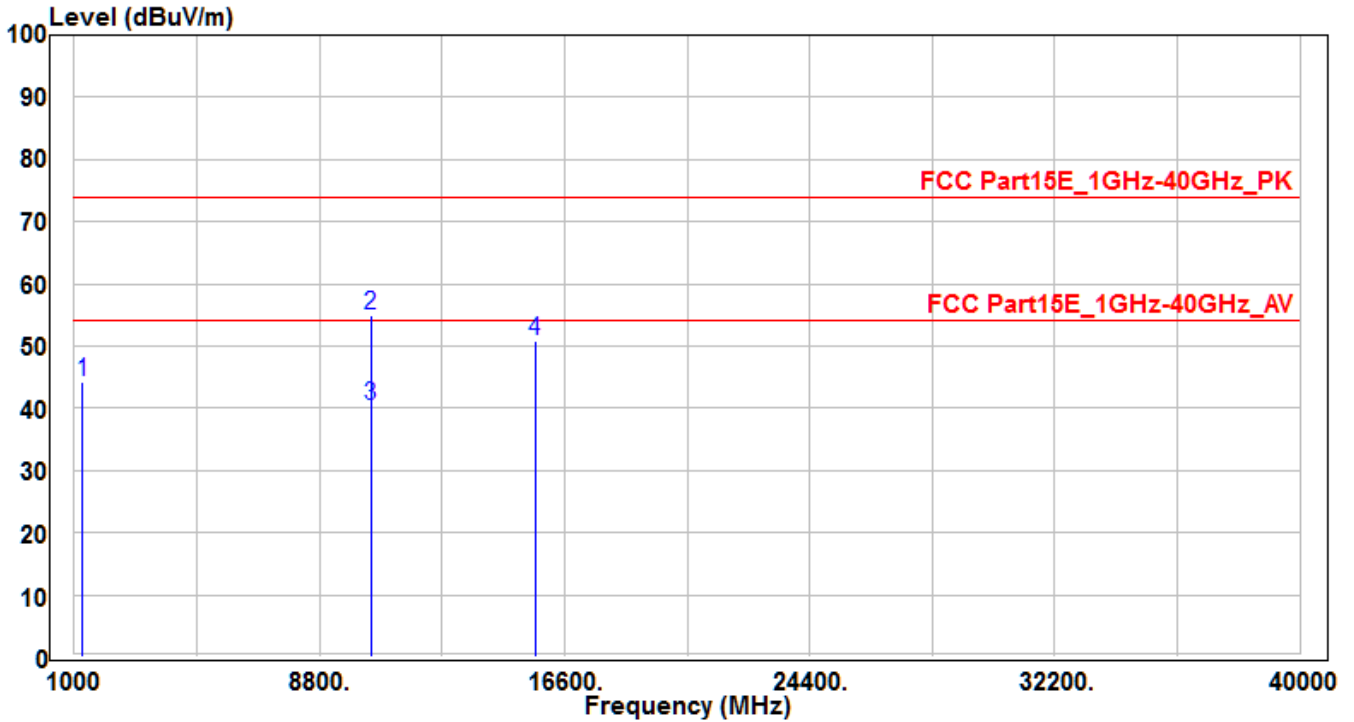

No	Frequency (MHz)	Reading (dBuV)	C.F (dB)	Measurement (dBuV/m)	Margin (dB)	Limit (dBuV/m)	Height (cm)	Angle (deg)	Remark (QP/PK/AV)
1	1265.36	51.24	-6.9	44.34	-29.66	74	150	400	Peak
2	*	37.94	17.04	54.98	-19.02	74	155	400	Peak
3	*	23.46	17.04	40.5	-13.5	54	155	400	Average
4	15660	29.94	20.84	50.78	-23.22	74	150	400	Peak

Note : The EUT Power by Notebook PC

1. " * " means this data is the worst emission level.
2. .C.F (Correction Factor) = Antenna Factor (dB)+ Cable Loss (dB) – Preamplifier(dB).
3. Measurement (dBuV/m) = Reading(dBuV) + C.F (Correction Factor).

EUT	WIFI USB DONGLE	Test Date	2017/12/25
Factor	BBHA 9120D (1GHz~18GHz)	Temp. / Humidity	25°C / 60%
Polarity	Horizontal	Site / Engineer	AC1 / Peter
Test Mode	MODE2 -CH48	Test Voltage	AC 120V/60Hz

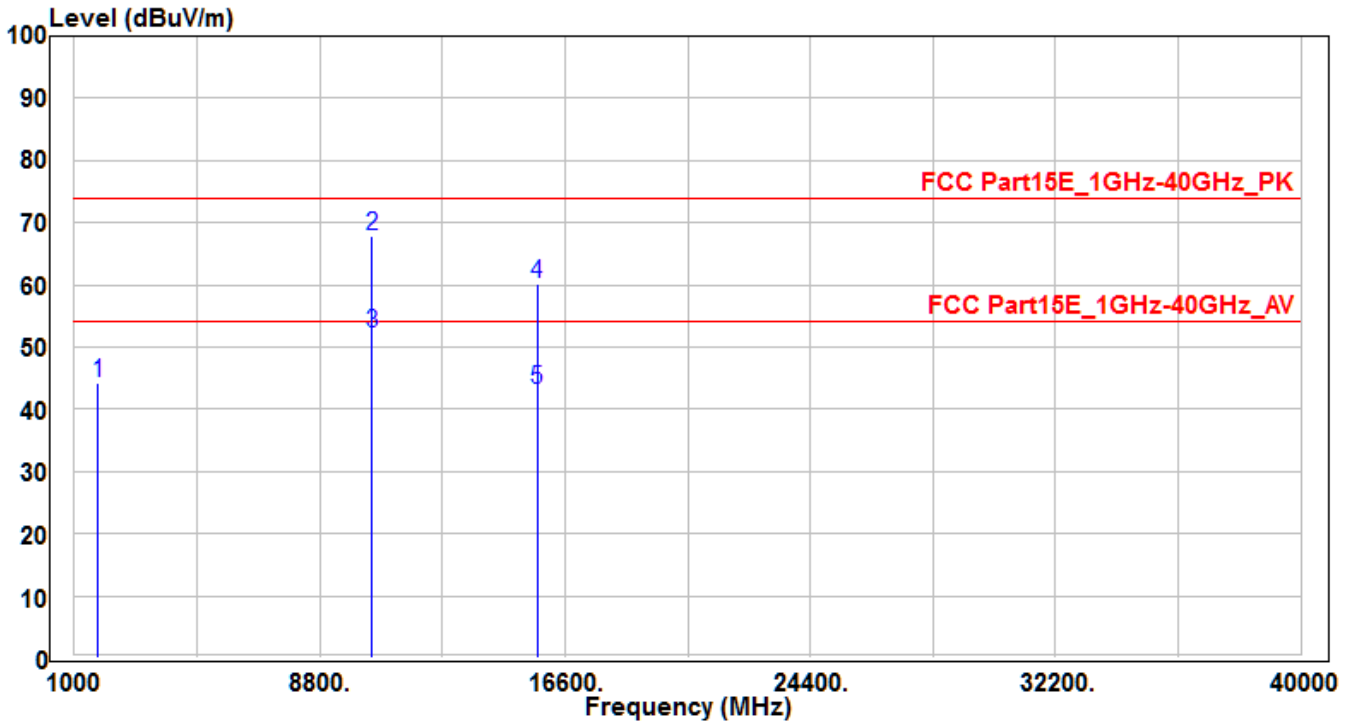

No	Frequency (MHz)	Reading (dBuV)	C.F (dB)	Measurement (dBuV/m)	Margin (dB)	Limit (dBuV/m)	Height (cm)	Angle (deg)	Remark (QP/PK/AV)
1	1753.26	49.6	-5.46	44.14	-29.86	74	150	400	Peak
2	* 10480	50.61	17.2	67.81	-6.19	74	150	-30	Peak
3	* 10480	35.03	17.2	52.23	-1.77	54	150	-30	Average
4	15720	39.33	20.77	60.1	-13.9	74	160	30	Peak
5	15720	22.41	20.77	43.18	-10.82	54	160	30	Average

Note : The EUT Power by Notebook PC

- " * " means this data is the worst emission level.
- .C.F (Correction Factor) = Antenna Factor (dB)+ Cable Loss (dB) – Preamplifier(dB).
- Measurement (dBuV/m) = Reading(dBuV) + C.F (Correction Factor).

EUT	WIFI USB DONGLE	Test Date	2017/12/25
Factor	BBHA 9120D (1GHz~18GHz)	Temp. / Humidity	25°C / 60%
Polarity	Vertical	Site / Engineer	AC1 / Peter
Test Mode	MODE2 -CH48	Test Voltage	AC 120V/60Hz

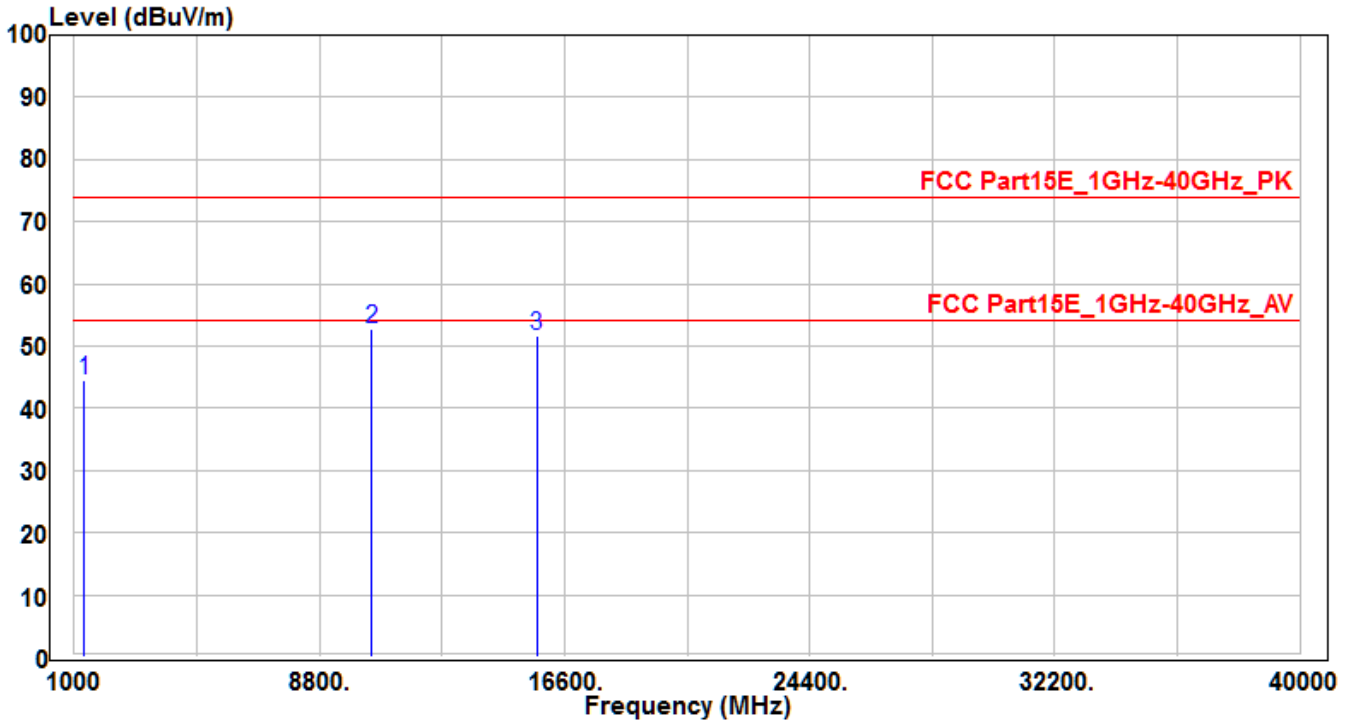

No	Frequency (MHz)	Reading (dBuV)	C.F (dB)	Measurement (dBuV/m)	Margin (dB)	Limit (dBuV/m)	Height (cm)	Angle (deg)	Remark (QP/PK/AV)
1	1330	51.2	-6.74	44.46	-29.54	74	150	400	Peak
2	* 10480	35.45	17.2	52.65	-21.35	74	150	400	Peak
3	15720	30.92	20.77	51.69	-22.31	74	150	400	Peak

Note : The EUT Power by Notebook PC

1. " * " means this data is the worst emission level.
2. .C.F (Correction Factor) = Antenna Factor (dB)+ Cable Loss (dB) – Preamplifier(dB).
3. Measurement (dBuV/m) = Reading(dBuV) + C.F (Correction Factor).

EUT	WIFI USB DONGLE	Test Date	2017/12/25
Factor	BBHA 9120D (1GHz~18GHz)	Temp. / Humidity	25°C / 60%
Polarity	Horizontal	Site / Engineer	AC1 / Peter
Test Mode	MODE2 -CH149	Test Voltage	AC 120V/60Hz

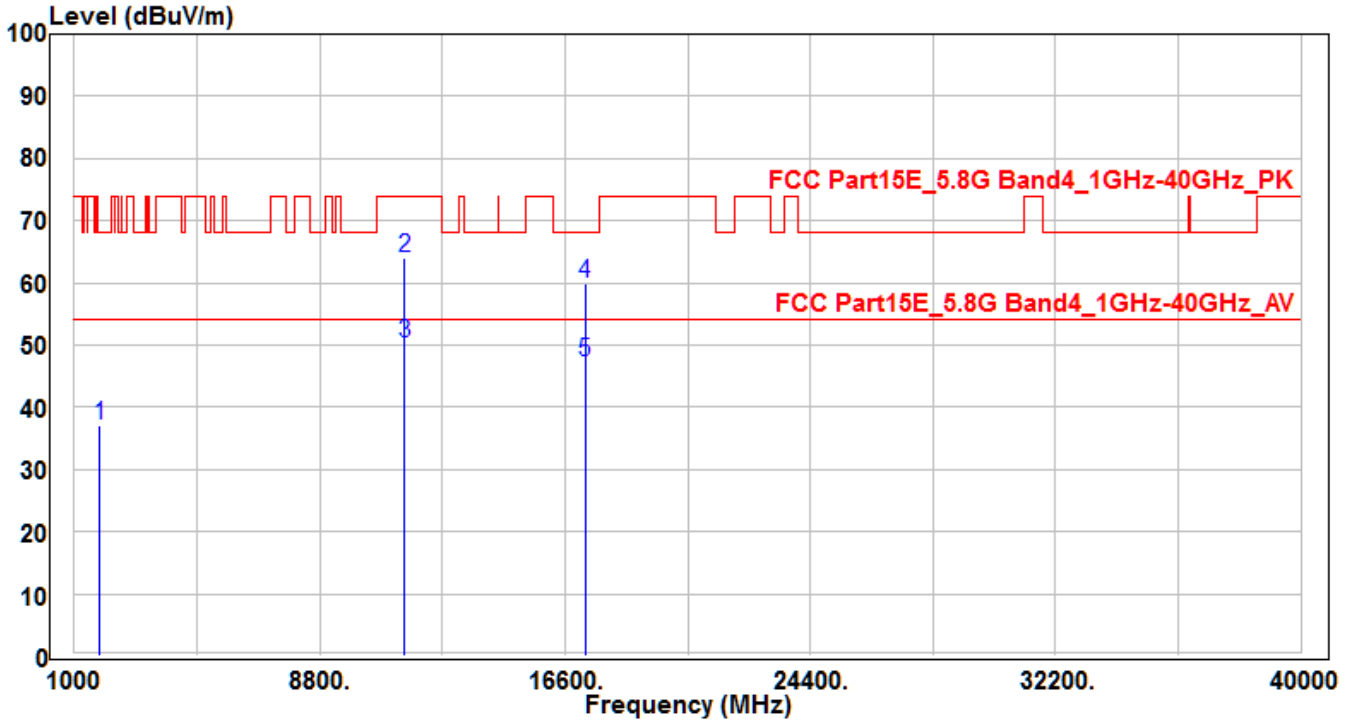

No	Frequency (MHz)	Reading (dBuV)	C.F (dB)	Measurement (dBuV/m)	Margin (dB)	Limit (dBuV/m)	Height (cm)	Angle (deg)	Remark (QP/PK/AV)	
1	1820.36	42.24	-5.24	37	-31.2	68.2	150	400	Peak	
2	*	11490	45.61	18.35	63.96	-10.04	74	150	370	Peak
3	*	11490	31.89	18.35	50.24	-3.76	54	150	370	Average
4		17235	33	26.96	59.96	-8.24	68.2	180	50	Peak
5		17235	20.19	26.96	47.15	-6.85	54	180	50	Average

Note : The EUT Power by Notebook PC

- "*" means this data is the worst emission level.
- .C.F (Correction Factor) = Antenna Factor (dB)+ Cable Loss (dB) – Preamplifier(dB).
- Measurement (dBuV/m) = Reading(dBuV) + C.F (Correction Factor).

EUT	WIFI USB DONGLE	Test Date	2017/12/25
Factor	BBHA 9120D (1GHz~18GHz)	Temp. / Humidity	25°C / 60%
Polarity	Vertical	Site / Engineer	AC1 / Peter
Test Mode	MODE2 -CH149	Test Voltage	AC 120V/60Hz

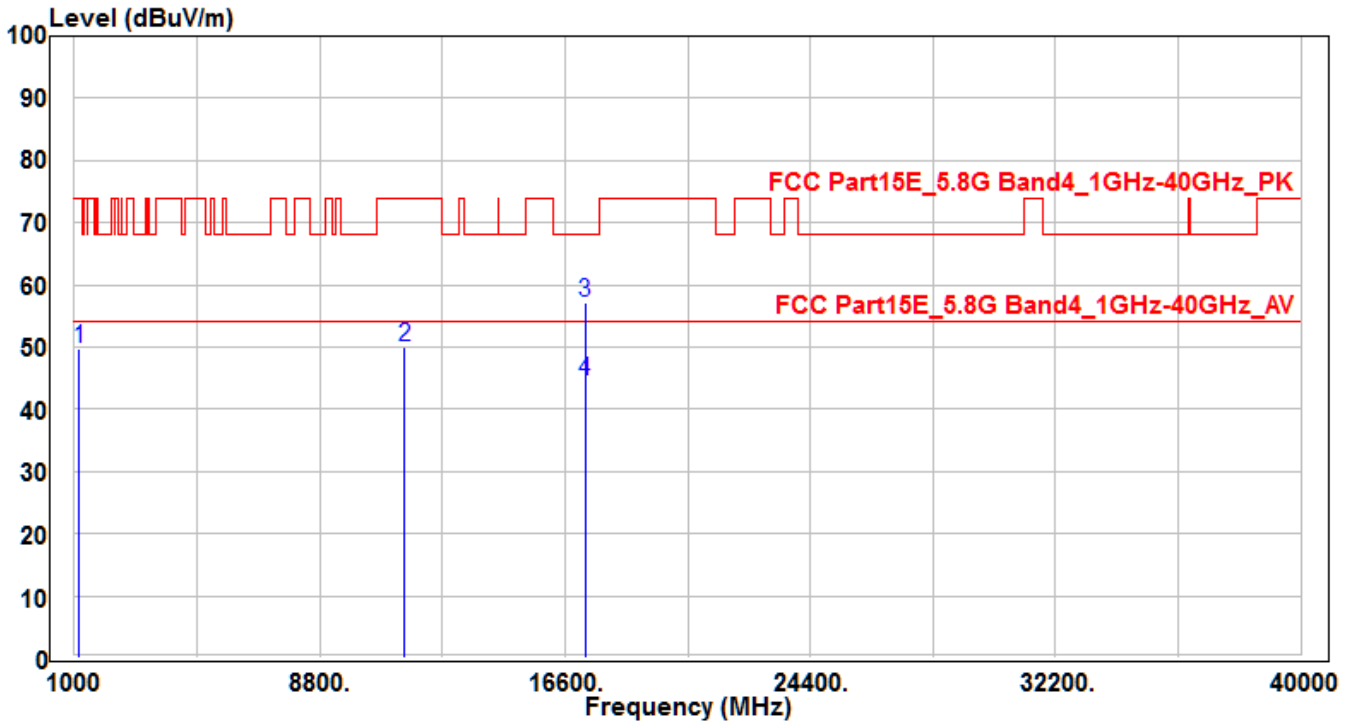

No	Frequency (MHz)	Reading (dBuV)	C.F (dB)	Measurement (dBuV/m)	Margin (dB)	Limit (dBuV/m)	Height (cm)	Angle (deg)	Remark (QP/PK/AV)
1	1154.96	56.79	-7.18	49.61	-24.39	74	150	400	Peak
2	11490	31.67	18.35	50.02	-23.98	74	150	400	Peak
3	* 17235	30.32	26.96	57.28	-10.92	68.2	170	400	Peak
4	* 17235	17.68	26.96	44.64	-9.36	54	170	400	Average

Note : The EUT Power by Notebook PC

1. " * " means this data is the worst emission level.
2. .C.F (Correction Factor) = Antenna Factor (dB)+ Cable Loss (dB) – Preamplifier(dB).
3. Measurement (dBuV/m) = Reading(dBuV) + C.F (Correction Factor).

EUT	WIFI USB DONGLE	Test Date	2017/12/25
Factor	BBHA 9120D (1GHz~18GHz)	Temp. / Humidity	25°C / 60%
Polarity	Horizontal	Site / Engineer	AC1 / Peter
Test Mode	MODE2 -CH157	Test Voltage	AC 120V/60Hz

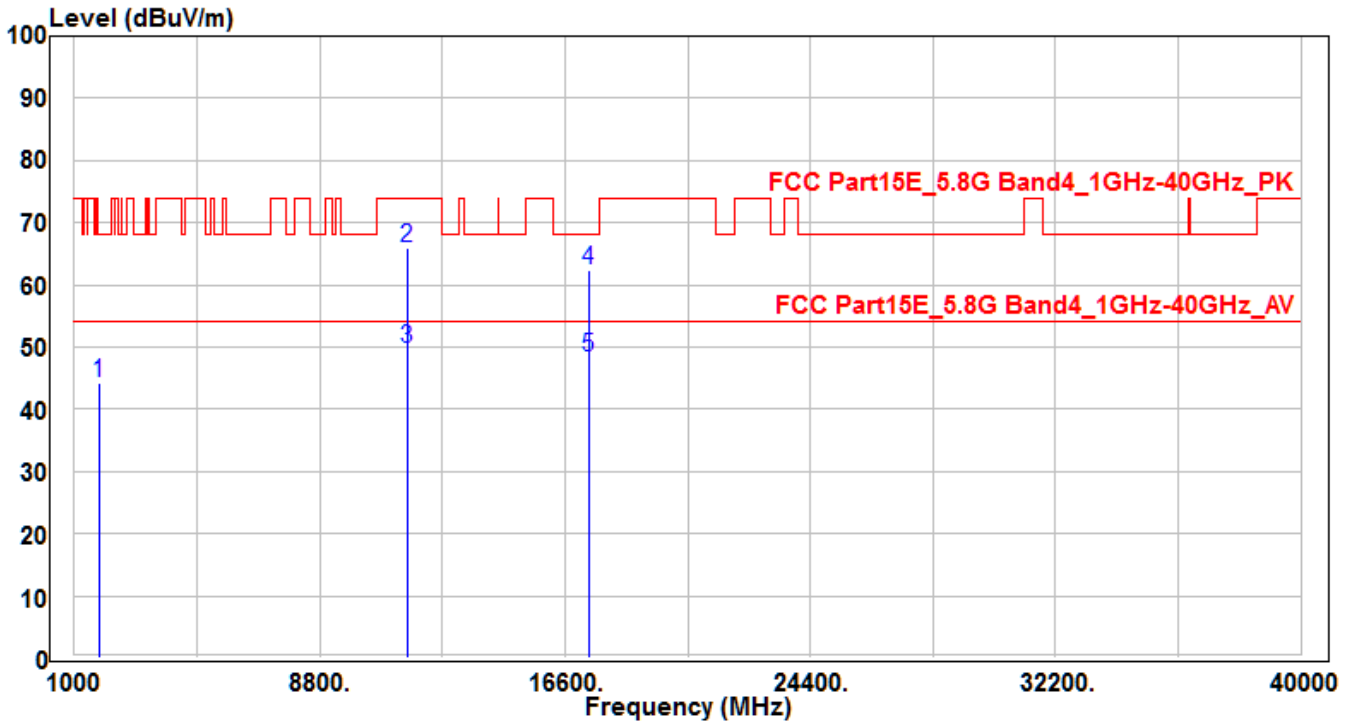

No	Frequency (MHz)	Reading (dBuV)	C.F (dB)	Measurement (dBuV/m)	Margin (dB)	Limit (dBuV/m)	Height (cm)	Angle (deg)	Remark (QP/PK/AV)	
1	1784.51	49.68	-5.35	44.33	-23.87	68.2	150	400	Peak	
2	*	11570	47.72	18.24	65.96	-8.04	74	170	375	Peak
3	*	11570	31.52	18.24	49.76	-4.24	54	170	375	Average
4		17355	34.46	27.81	62.27	-5.93	68.2	165	400	Peak
5		17355	20.57	27.81	48.38	-5.62	54	165	400	Average

Note : The EUT Power by Notebook PC

- "*" means this data is the worst emission level.
- .C.F (Correction Factor) = Antenna Factor (dB)+ Cable Loss (dB) – Preamplifier(dB).
- Measurement (dBuV/m) = Reading(dBuV) + C.F (Correction Factor).

EUT	WIFI USB DONGLE	Test Date	2017/12/25
Factor	BBHA 9120D (1GHz~18GHz)	Temp. / Humidity	25°C / 60%
Polarity	Vertical	Site / Engineer	AC1 / Peter
Test Mode	MODE2 -CH157	Test Voltage	AC 120V/60Hz

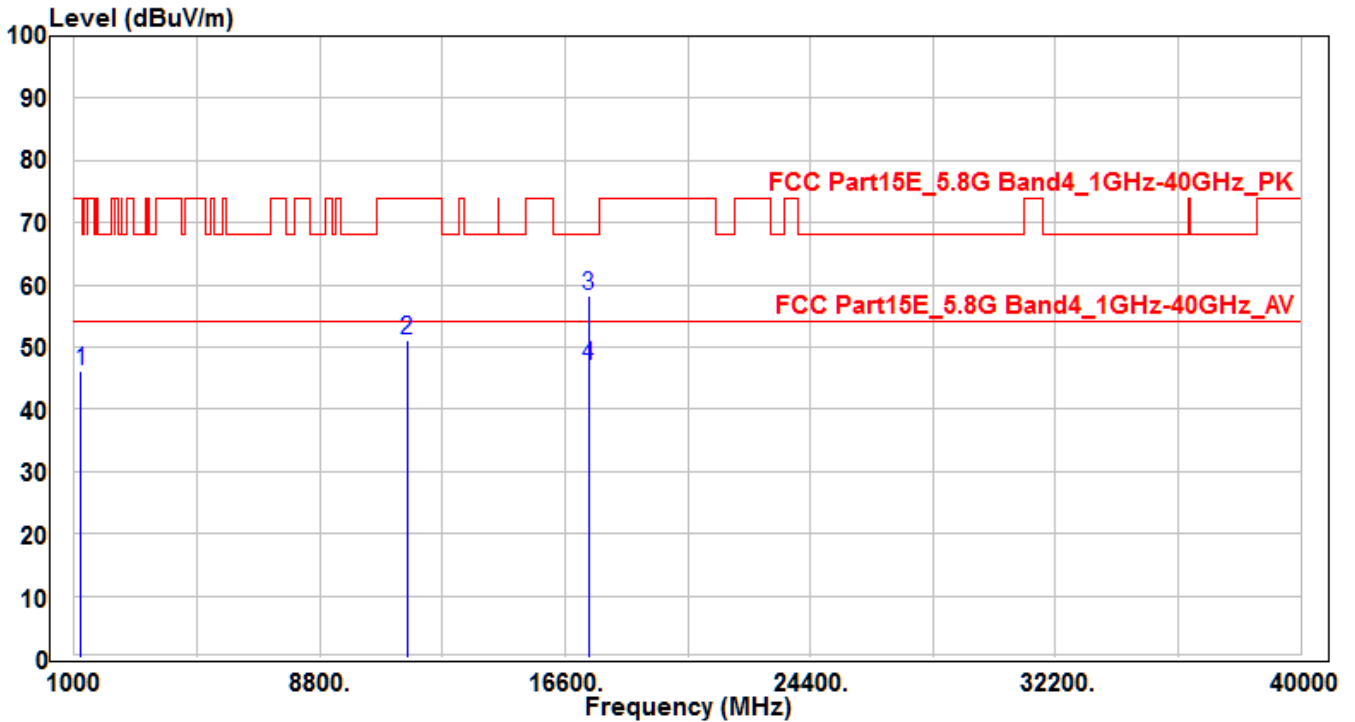

No	Frequency (MHz)	Reading (dBuV)	C.F (dB)	Measurement (dBuV/m)	Margin (dB)	Limit (dBuV/m)	Height (cm)	Angle (deg)	Remark (QP/PK/AV)
1	1205.98	53.23	-7.05	46.18	-27.82	74	150	400	Peak
2	11570	32.8	18.24	51.04	-22.96	74	150	400	Peak
3	*	30.5	27.81	58.31	-9.89	68.2	220	10	Peak
4	*	19.06	27.81	46.87	-7.13	54	220	10	Average

Note : The EUT Power by Notebook PC

1. " * " means this data is the worst emission level.
2. .C.F (Correction Factor) = Antenna Factor (dB)+ Cable Loss (dB) – Preamplifier(dB).
3. Measurement (dBuV/m) = Reading(dBuV) + C.F (Correction Factor).

EUT	WIFI USB DONGLE	Test Date	2017/12/25
Factor	BBHA 9120D (1GHz~18GHz)	Temp. / Humidity	25°C / 60%
Polarity	Horizontal	Site / Engineer	AC1 / Peter
Test Mode	MODE2 -CH165	Test Voltage	AC 120V/60Hz

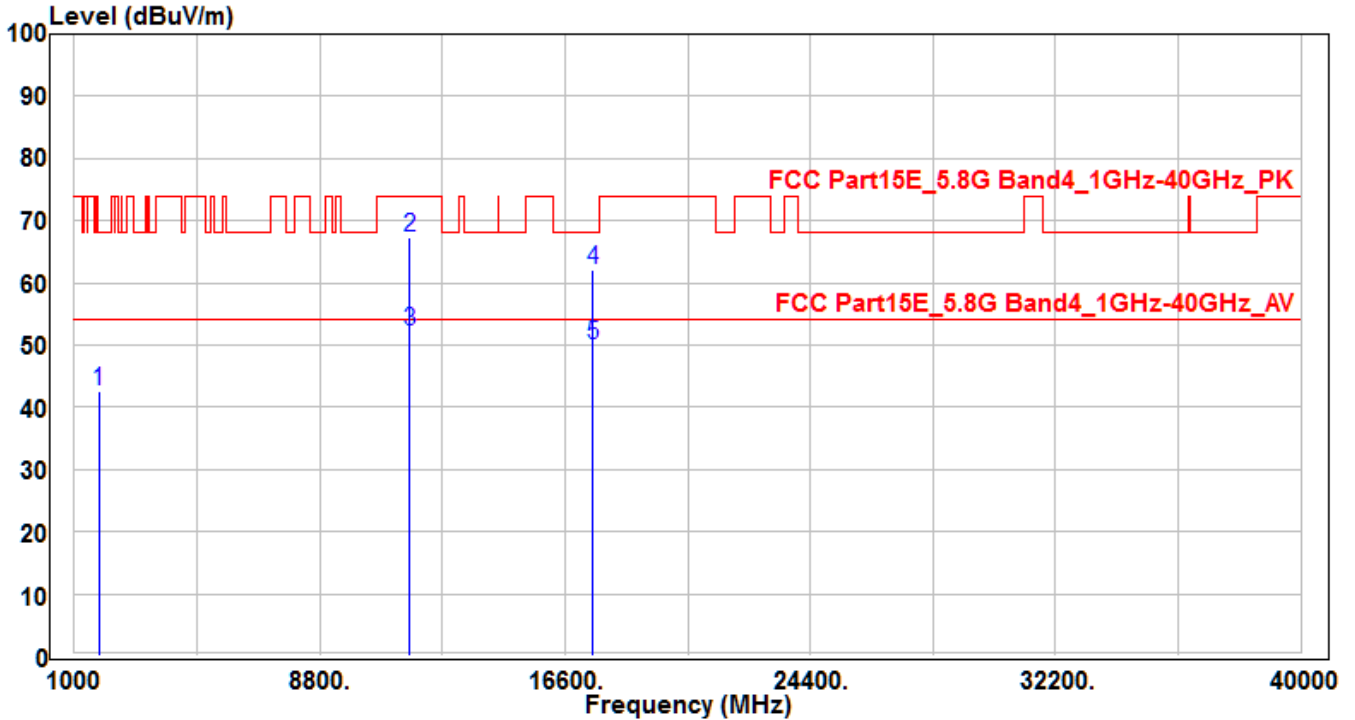

No	Frequency (MHz)	Reading (dBuV)	C.F (dB)	Measurement (dBuV/m)	Margin (dB)	Limit (dBuV/m)	Height (cm)	Angle (deg)	Remark (QP/PK/AV)	
1	1786.59	47.85	-5.35	42.5	-25.7	68.2	150	400	Peak	
2	*	11650	49.28	18.1	67.38	-6.62	74	150	-40	Peak
3	*	11650	34.02	18.1	52.12	-1.88	54	150	-40	Average
4	17475	33.4	28.66	62.06	-6.14	68.2	150	45	Peak	
5	17475	21.27	28.66	49.93	-4.07	54	150	45	Average	

Note : The EUT Power by Notebook PC

- "*" means this data is the worst emission level.
- .C.F (Correction Factor) = Antenna Factor (dB)+ Cable Loss (dB) – Preamplifier(dB).
- Measurement (dBuV/m) = Reading(dBuV) + C.F (Correction Factor).

EUT	WIFI USB DONGLE	Test Date	2017/12/25
Factor	BBHA 9120D (1GHz~18GHz)	Temp. / Humidity	25°C / 60%
Polarity	Vertical	Site / Engineer	AC1 / Peter
Test Mode	MODE2 -CH165	Test Voltage	AC 120V/60Hz

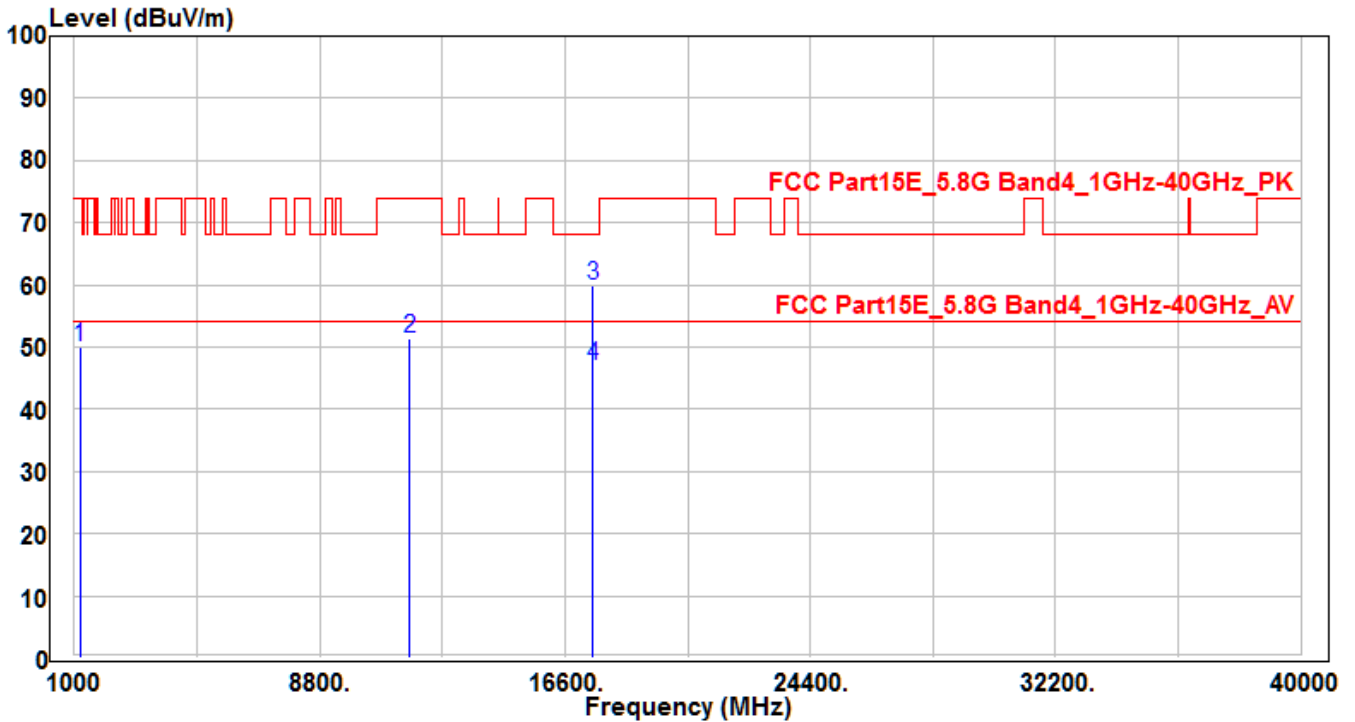

No	Frequency (MHz)	Reading (dBuV)	C.F (dB)	Measurement (dBuV/m)	Margin (dB)	Limit (dBuV/m)	Height (cm)	Angle (deg)	Remark (QP/PK/AV)
1	1185.4	57.1	-7.1	50	-24	74	150	400	Peak
2	11650	33.36	18.1	51.46	-22.54	74	150	400	Peak
3	*	31.18	28.66	59.84	-8.36	68.2	190	390	Peak
4	*	18.3	28.66	46.96	-7.04	54	190	390	Average

Note : The EUT Power by Notebook PC

1. " * " means this data is the worst emission level.
2. .C.F (Correction Factor) = Antenna Factor (dB)+ Cable Loss (dB) – Preamplifier(dB).
3. Measurement (dBuV/m) = Reading(dBuV) + C.F (Correction Factor).

EUT	WIFI USB DONGLE	Test Date	2017/12/25
Factor	BBHA 9120D (1GHz~18GHz)	Temp. / Humidity	25°C / 60%
Polarity	Horizontal	Site / Engineer	AC1 / Peter
Test Mode	MODE3 -CH38	Test Voltage	AC 120V/60Hz

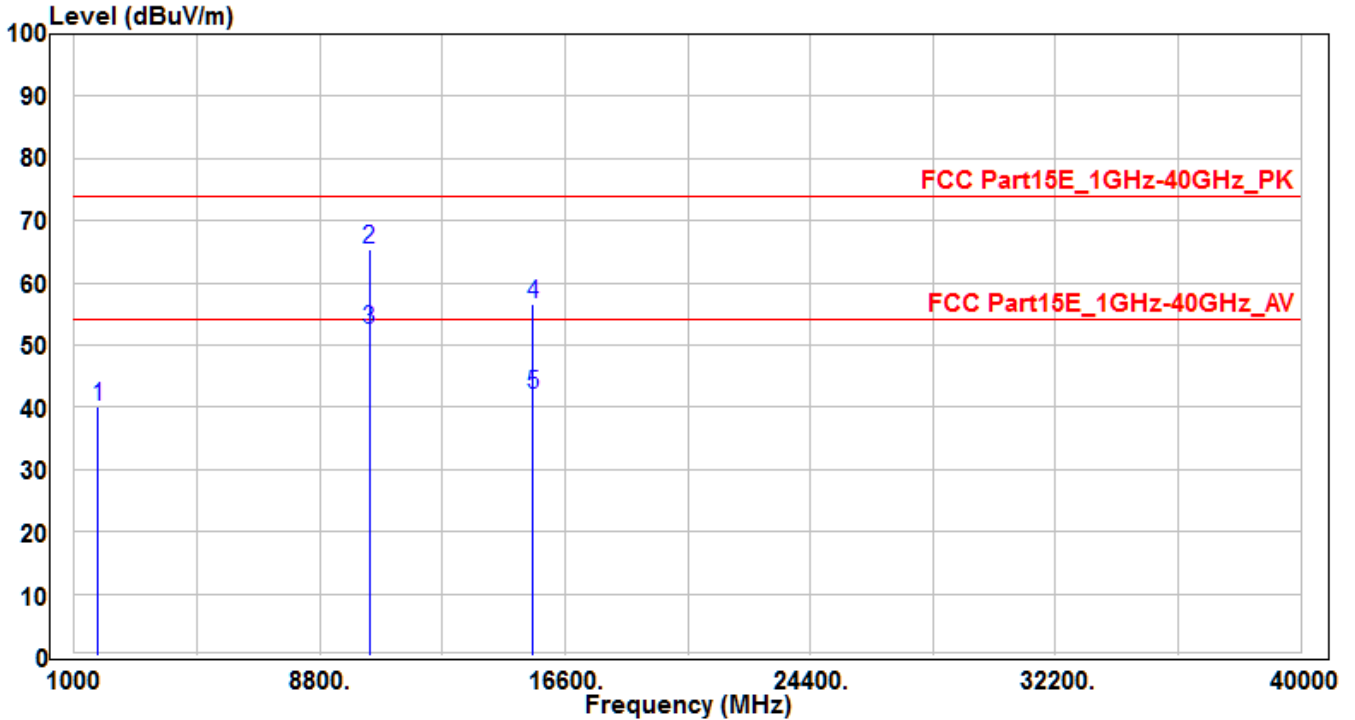

No	Frequency (MHz)	Reading (dBuV)	C.F (dB)	Measurement (dBuV/m)	Margin (dB)	Limit (dBuV/m)	Height (cm)	Angle (deg)	Remark (QP/PK/AV)	
1	1745.254	45.6	-5.49	40.11	-33.89	74	150	400	Peak	
2	*	10380	48.5	16.82	65.32	-8.68	74	200	325	Peak
3	*	10380	35.73	16.82	52.55	-1.45	54	200	325	Average
4		15570	35.67	20.96	56.63	-17.37	74	170	20	Peak
5		15570	21.19	20.96	42.15	-11.85	54	170	20	Average

Note : The EUT Power by Notebook PC

- " * " means this data is the worst emission level.
- .C.F (Correction Factor) = Antenna Factor (dB)+ Cable Loss (dB) – Preamplifier(dB).
- Measurement (dBuV/m) = Reading(dBuV) + C.F (Correction Factor).

EUT	WIFI USB DONGLE	Test Date	2017/12/25
Factor	BBHA 9120D (1GHz~18GHz)	Temp. / Humidity	25°C / 60%
Polarity	Vertical	Site / Engineer	AC1 / Peter
Test Mode	MODE3 -CH38	Test Voltage	AC 120V/60Hz

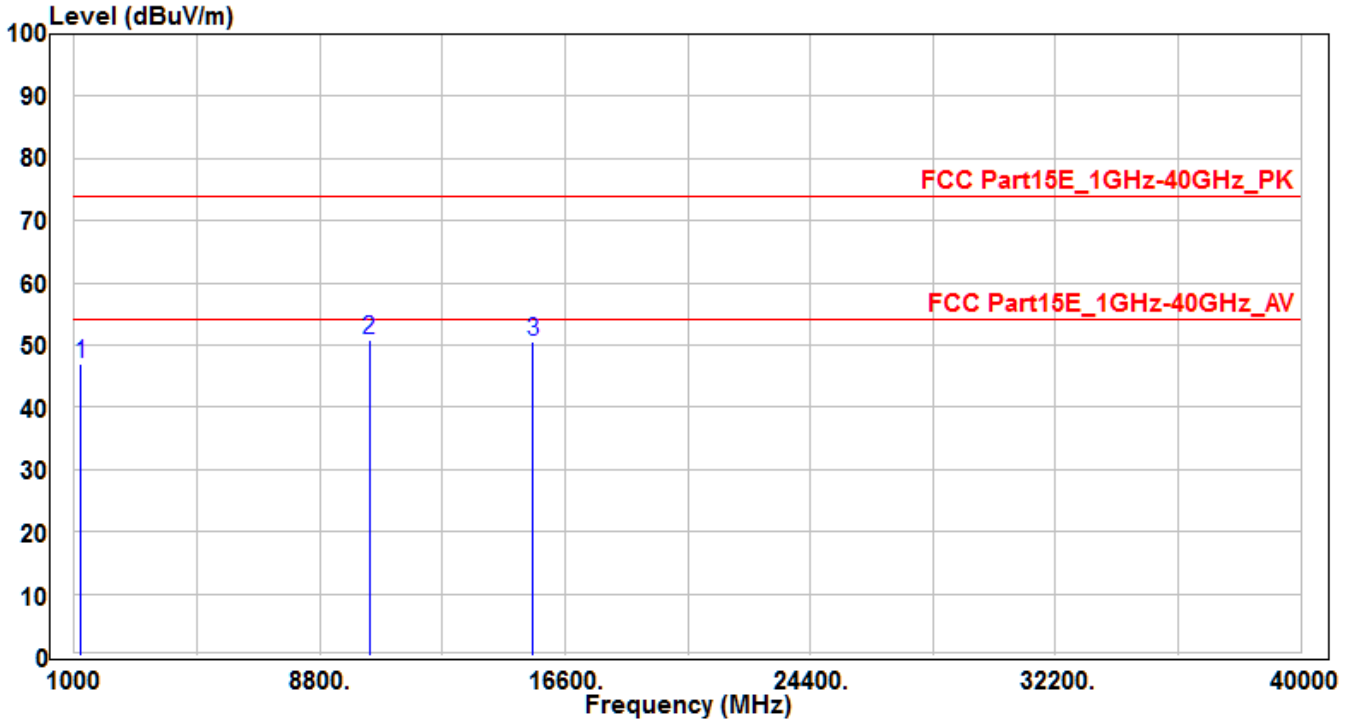

No	Frequency (MHz)	Reading (dBuV)	C.F (dB)	Measurement (dBuV/m)	Margin (dB)	Limit (dBuV/m)	Height (cm)	Angle (deg)	Remark (QP/PK/AV)
1	1200.63	54.1	-7.06	47.04	-26.96	74	150	400	Peak
2	* 10380	34.13	16.82	50.95	-23.05	74	150	400	Peak
3	15570	29.73	20.96	50.69	-23.31	74	150	400	Peak

Note : The EUT Power by Notebook PC

- " * " means this data is the worst emission level.
- .C.F (Correction Factor) = Antenna Factor (dB)+ Cable Loss (dB) – Preamplifier(dB).
- Measurement (dBuV/m) = Reading(dBuV) + C.F (Correction Factor).

EUT	WIFI USB DONGLE	Test Date	2017/12/25
Factor	BBHA 9120D (1GHz~18GHz)	Temp. / Humidity	25°C / 60%
Polarity	Horizontal	Site / Engineer	AC1 / Peter
Test Mode	MODE3 -CH46	Test Voltage	AC 120V/60Hz

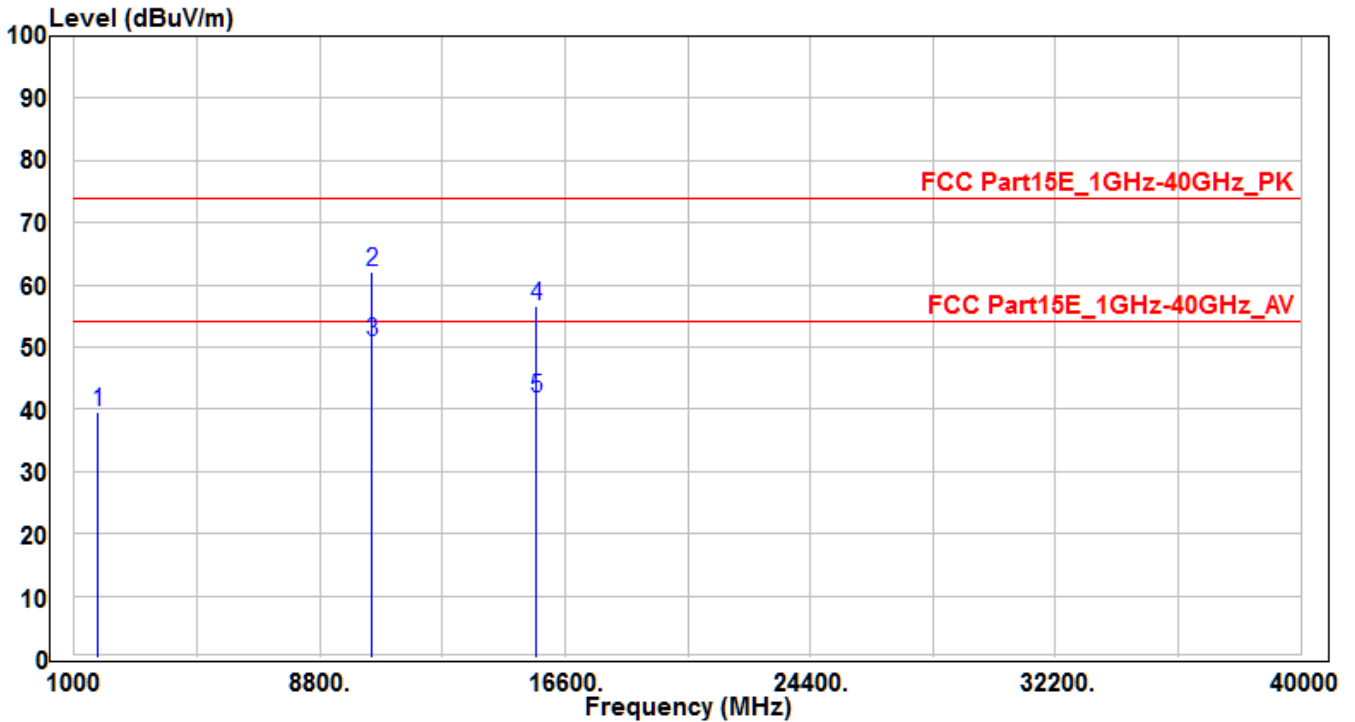

No	Frequency (MHz)	Reading (dBuV)	C.F (dB)	Measurement (dBuV/m)	Margin (dB)	Limit (dBuV/m)	Height (cm)	Angle (deg)	Remark (QP/PK/AV)	
1	1755	45	-5.46	39.54	-34.46	74	150	400	Peak	
2	*	10460	44.86	17.12	61.98	-12.02	74	230	325	Peak
3	*	10460	33.85	17.12	50.97	-3.03	54	230	325	Average
4	15690	35.91	20.81	56.72	-17.28	74	175	15	Peak	
5	15690	21.06	20.81	41.87	-12.13	54	175	15	Average	

Note : The EUT Power by Notebook PC

- " * " means this data is the worst emission level.
- .C.F (Correction Factor) = Antenna Factor (dB)+ Cable Loss (dB) – Preamplifier(dB).
- Measurement (dBuV/m) = Reading(dBuV) + C.F (Correction Factor).

EUT	WIFI USB DONGLE	Test Date	2017/12/25
Factor	BBHA 9120D (1GHz~18GHz)	Temp. / Humidity	25°C / 60%
Polarity	Vertical	Site / Engineer	AC1 / Peter
Test Mode	MODE3 -CH46	Test Voltage	AC 120V/60Hz

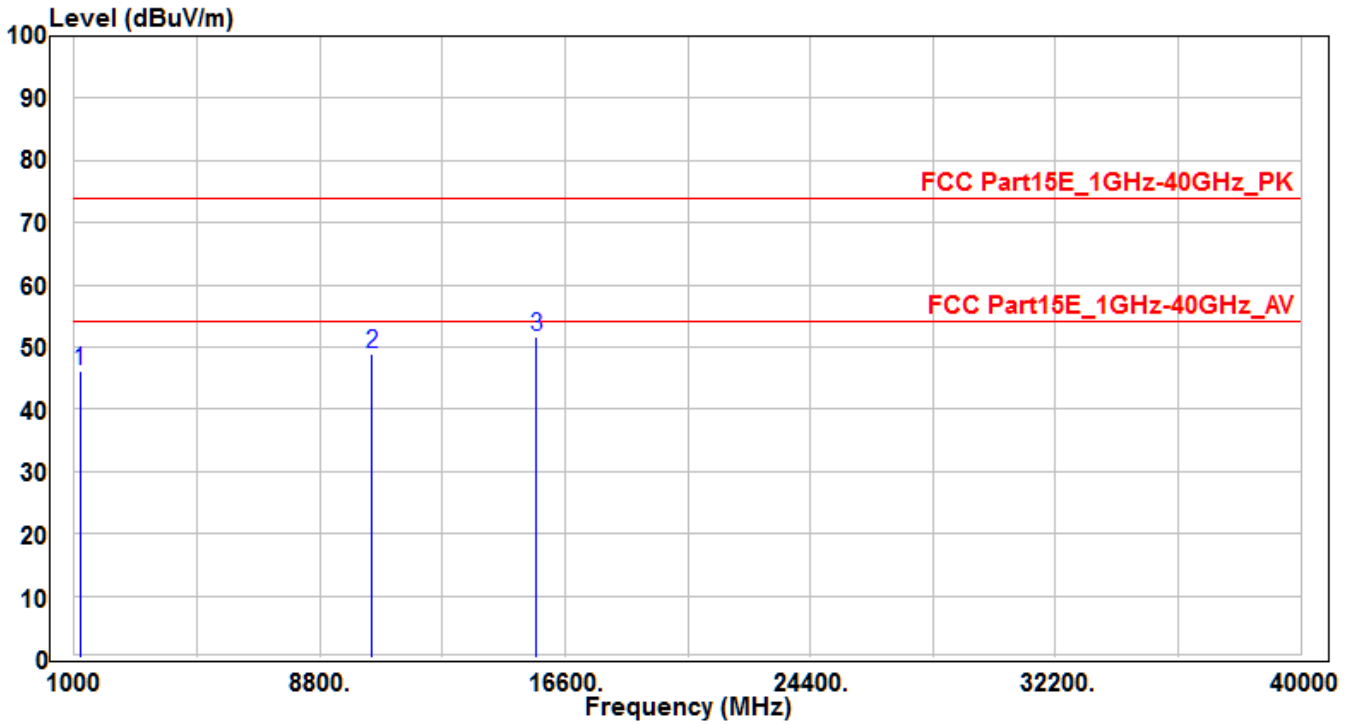

No	Frequency (MHz)	Reading (dBuV)	C.F (dB)	Measurement (dBuV/m)	Margin (dB)	Limit (dBuV/m)	Height (cm)	Angle (deg)	Remark (QP/PK/AV)
1	1195.65	53.36	-7.07	46.29	-27.71	74	150	400	Peak
2	10460	31.75	17.12	48.87	-25.13	74	150	400	Peak
3	* 15690	30.84	20.81	51.65	-22.35	74	150	400	Peak

Note : The EUT Power by Notebook PC

1. " * " means this data is the worst emission level.
2. .C.F (Correction Factor) = Antenna Factor (dB)+ Cable Loss (dB) – Preamplifier(dB).
3. Measurement (dBuV/m) = Reading(dBuV) + C.F (Correction Factor).

EUT	WIFI USB DONGLE	Test Date	2017/12/25
Factor	BBHA 9120D (1GHz~18GHz)	Temp. / Humidity	25°C / 60%
Polarity	Horizontal	Site / Engineer	AC1 / Peter
Test Mode	MODE3 -CH151	Test Voltage	AC 120V/60Hz

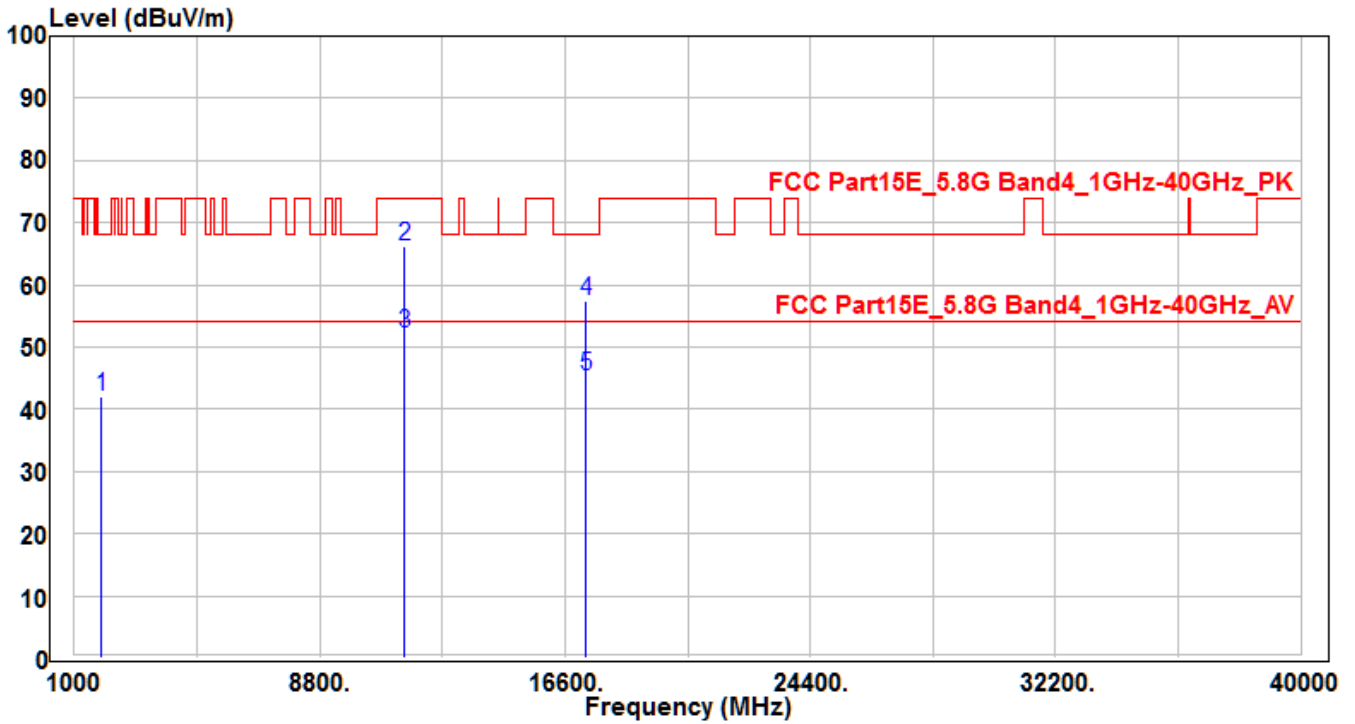

No	Frequency (MHz)	Reading (dBuV)	C.F (dB)	Measurement (dBuV/m)	Margin (dB)	Limit (dBuV/m)	Height (cm)	Angle (deg)	Remark (QP/PK/AV)	
1	1860.1	47.25	-5.1	42.15	-26.05	68.2	150	400	Peak	
2	*	11510	47.89	18.34	66.23	-7.77	74	165	350	Peak
3	*	11510	33.98	18.34	52.32	-1.68	54	165	350	Average
4		17265	30.2	27.19	57.39	-10.81	68.2	215	40	Peak
5		17265	18.17	27.19	45.36	-8.64	54	215	40	Average

Note : The EUT Power by Notebook PC

- " * " means this data is the worst emission level.
- .C.F (Correction Factor) = Antenna Factor (dB)+ Cable Loss (dB) – Preamplifier(dB).
- Measurement (dBuV/m) = Reading(dBuV) + C.F (Correction Factor).

EUT	WIFI USB DONGLE	Test Date	2017/12/25
Factor	BBHA 9120D (1GHz~18GHz)	Temp. / Humidity	25°C / 60%
Polarity	Vertical	Site / Engineer	AC1 / Peter
Test Mode	MODE3 -CH151	Test Voltage	AC 120V/60Hz

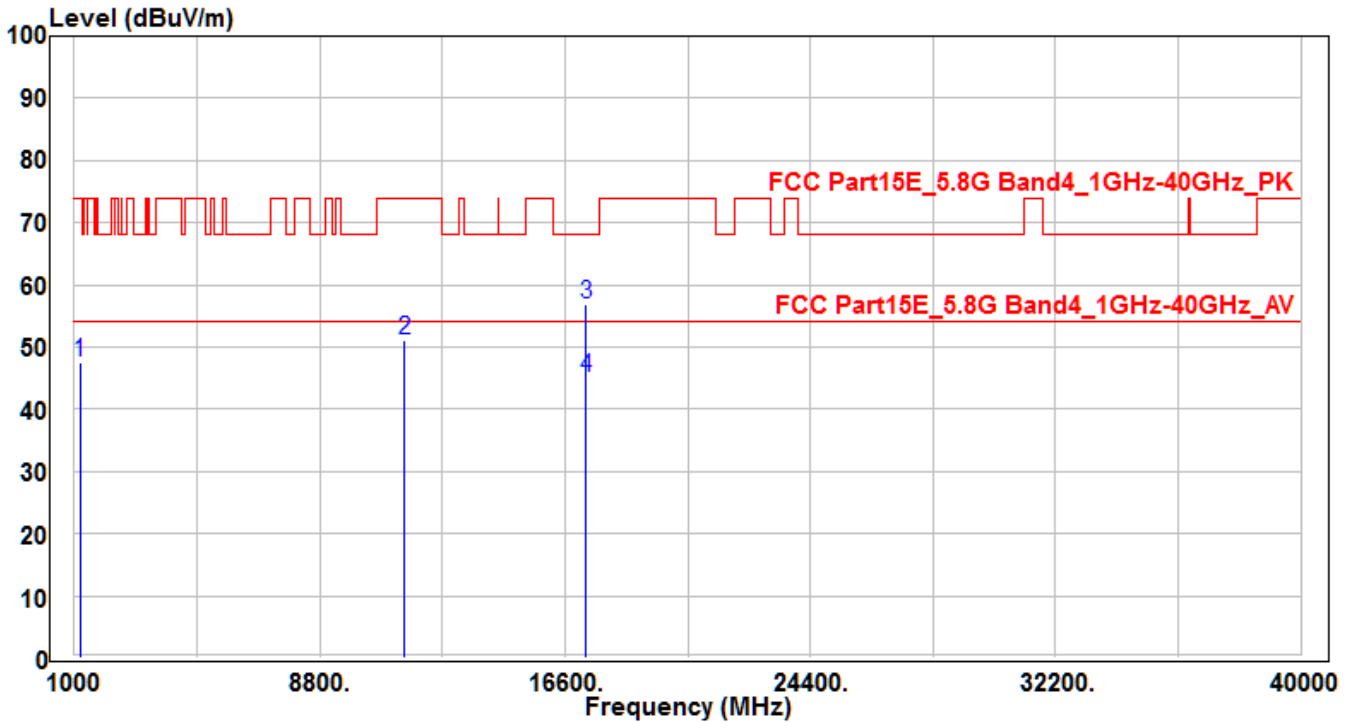

No	Frequency (MHz)	Reading (dBuV)	C.F (dB)	Measurement (dBuV/m)	Margin (dB)	Limit (dBuV/m)	Height (cm)	Angle (deg)	Remark (QP/PK/AV)
1	1185.998	54.77	-7.1	47.67	-26.33	74	150	400	Peak
2	11510	32.67	18.34	51.01	-22.99	74	150	400	Peak
3	* 17265	29.66	27.19	56.85	-11.35	68.2	220	340	Peak
4	* 17265	17.81	27.19	45	-9	54	220	340	Average

Note : The EUT Power by Notebook PC

1. " * " means this data is the worst emission level.
2. .C.F (Correction Factor) = Antenna Factor (dB)+ Cable Loss (dB) – Preamplifier(dB).
3. Measurement (dBuV/m) = Reading(dBuV) + C.F (Correction Factor).

EUT	WIFI USB DONGLE	Test Date	2017/12/25
Factor	BBHA 9120D (1GHz~18GHz)	Temp. / Humidity	25°C / 60%
Polarity	Horizontal	Site / Engineer	AC1 / Peter
Test Mode	MODE3 -CH159	Test Voltage	AC 120V/60Hz

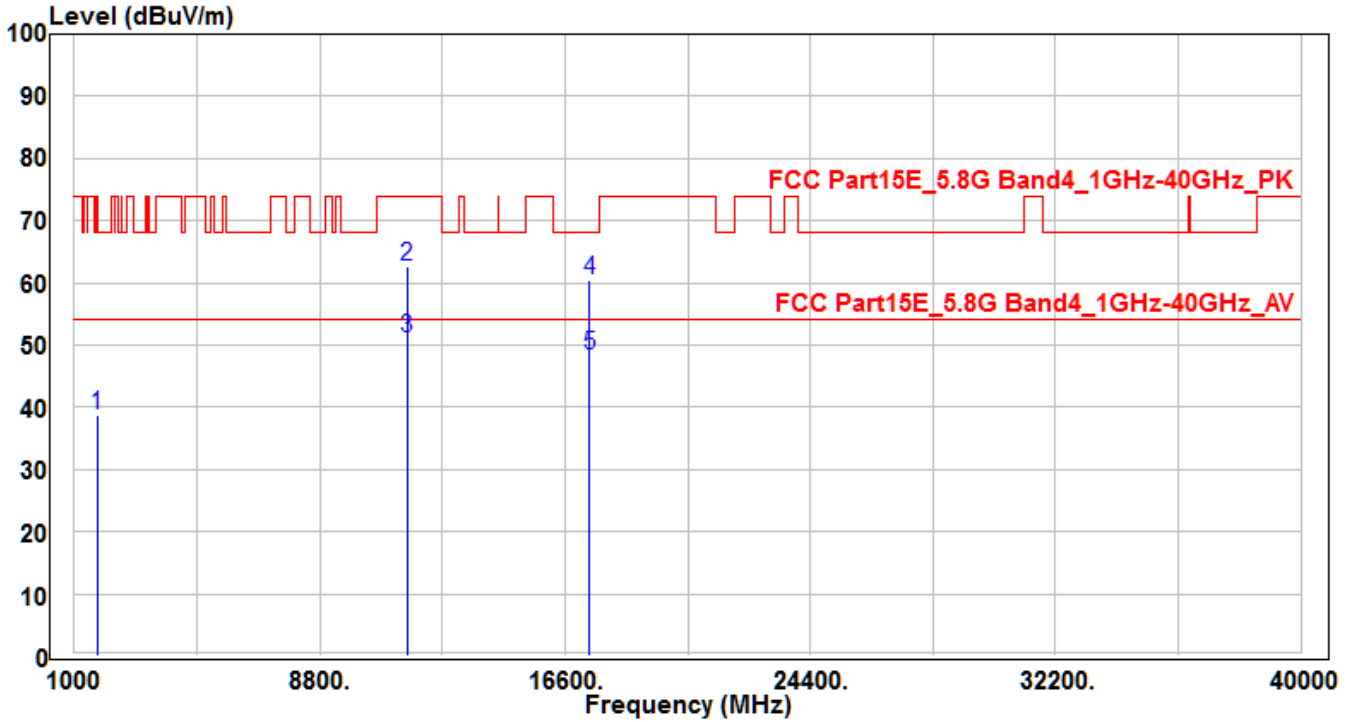

No	Frequency (MHz)	Reading (dBuV)	C.F (dB)	Measurement (dBuV/m)	Margin (dB)	Limit (dBuV/m)	Height (cm)	Angle (deg)	Remark (QP/PK/AV)
1	1721.41	44.44	-5.57	38.87	-35.13	74	150	400	Peak
2	* 11590	44.37	18.2	62.57	-11.43	74	200	400	Peak
3	* 11590	32.82	18.2	51.02	-2.98	54	200	400	Average
4	17385	32.57	28.02	60.59	-7.61	68.2	170	50	Peak

Note : The EUT Power by Notebook PC

1. " * " means this data is the worst emission level.
2. .C.F (Correction Factor) = Antenna Factor (dB)+ Cable Loss (dB) – Preamplifier(dB).
3. Measurement (dBuV/m) = Reading(dBuV) + C.F (Correction Factor).

EUT	WIFI USB DONGLE	Test Date	2017/12/25
Factor	BBHA 9120D (1GHz~18GHz)	Temp. / Humidity	25°C / 60%
Polarity	Vertical	Site / Engineer	AC1 / Peter
Test Mode	MODE3 -CH159	Test Voltage	AC 120V/60Hz

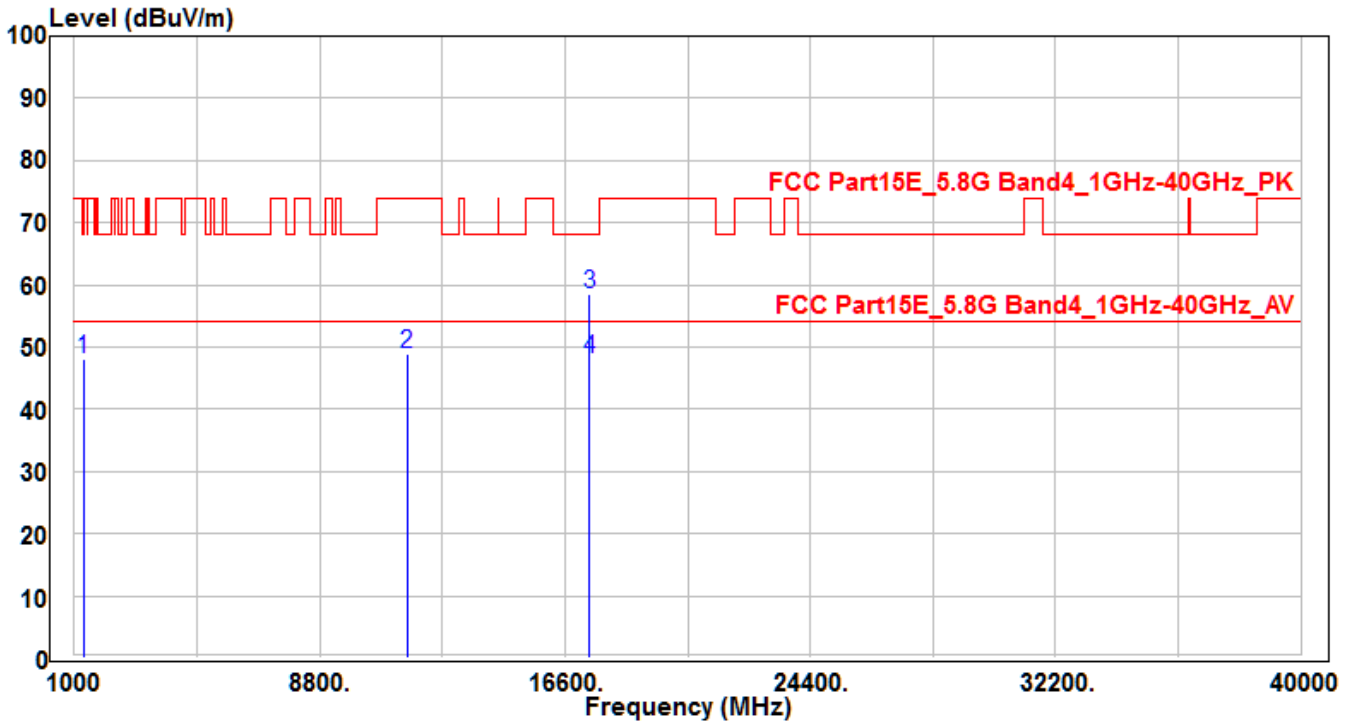

No	Frequency (MHz)	Reading (dBuV)	C.F (dB)	Measurement (dBuV/m)	Margin (dB)	Limit (dBuV/m)	Height (cm)	Angle (deg)	Remark (QP/PK/AV)
1	1296	54.99	-6.82	48.17	-20.03	68.2	150	400	Peak
2	11590	30.65	18.2	48.85	-25.15	74	150	400	Peak
3	* 17385	30.64	28.02	58.66	-9.54	68.2	305	-40	Peak
4	* 17385	19.96	28.02	47.98	-6.02	54	305	-40	Average

Note : The EUT Power by Notebook PC

1. " * " means this data is the worst emission level.
2. .C.F (Correction Factor) = Antenna Factor (dB)+ Cable Loss (dB) – Preamplifier(dB).
3. Measurement (dBuV/m) = Reading(dBuV) + C.F (Correction Factor).

EUT	WIFI USB DONGLE	Test Date	2017/12/25
Factor	BBHA 9120D (1GHz~18GHz)	Temp. / Humidity	25°C / 60%
Polarity	Horizontal	Site / Engineer	AC1 / Peter
Test Mode	MODE4 -CH42	Test Voltage	AC 120V/60Hz

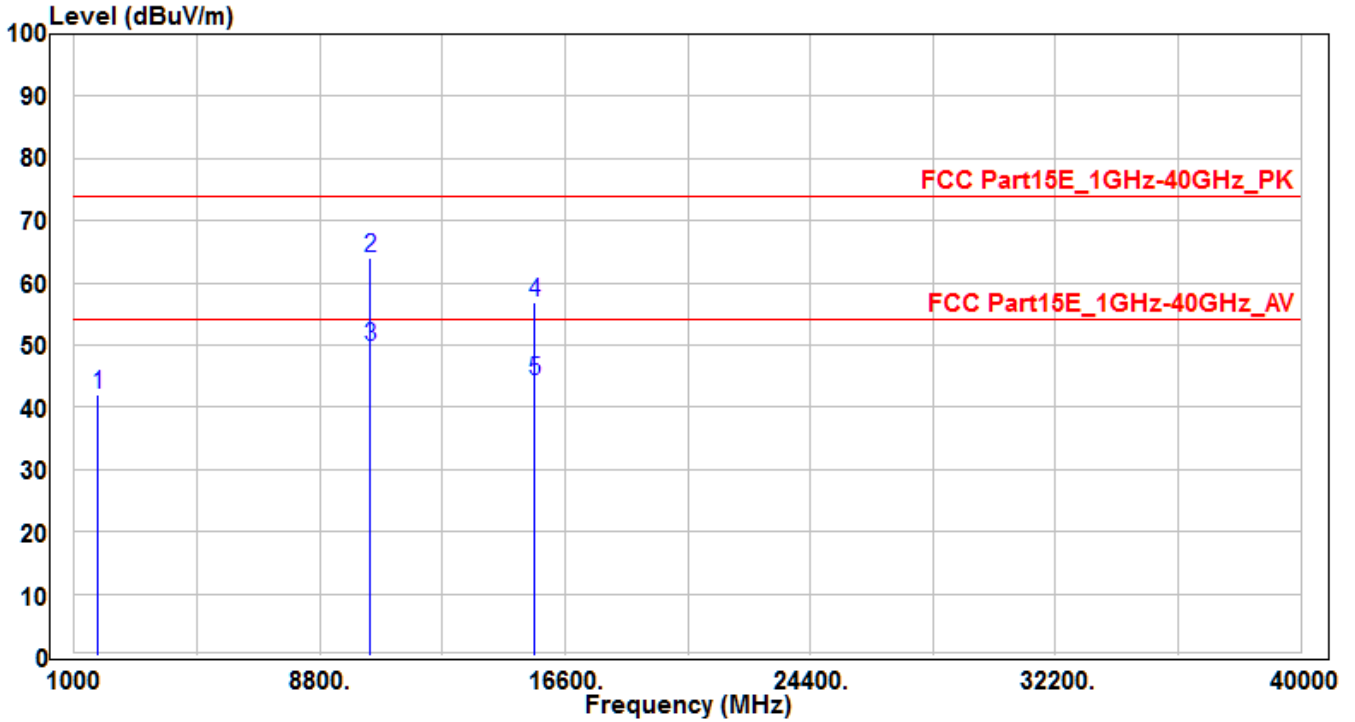

No	Frequency (MHz)	Reading (dBuV)	C.F (dB)	Measurement (dBuV/m)	Margin (dB)	Limit (dBuV/m)	Height (cm)	Angle (deg)	Remark (QP/PK/AV)
1	1763.3	47.58	-5.43	42.15	-31.85	74	150	400	Peak
2	* 10420	46.94	16.96	63.9	-10.1	74	230	-25	Peak
3	* 10420	32.77	16.96	49.73	-4.27	54	230	-25	Average
4	15630	36.07	20.88	56.95	-17.05	74	170	385	Peak
5	15630	23.34	20.88	44.22	-9.78	54	170	385	Average

Note : The EUT Power by Notebook PC

- " * " means this data is the worst emission level.
- .C.F (Correction Factor) = Antenna Factor (dB)+ Cable Loss (dB) – Preamplifier(dB).
- Measurement (dBuV/m) = Reading(dBuV) + C.F (Correction Factor).

EUT	WIFI USB DONGLE	Test Date	2017/12/25
Factor	BBHA 9120D (1GHz~18GHz)	Temp. / Humidity	25°C / 60%
Polarity	Vertical	Site / Engineer	AC1 / Peter
Test Mode	MODE4 -CH42	Test Voltage	AC 120V/60Hz

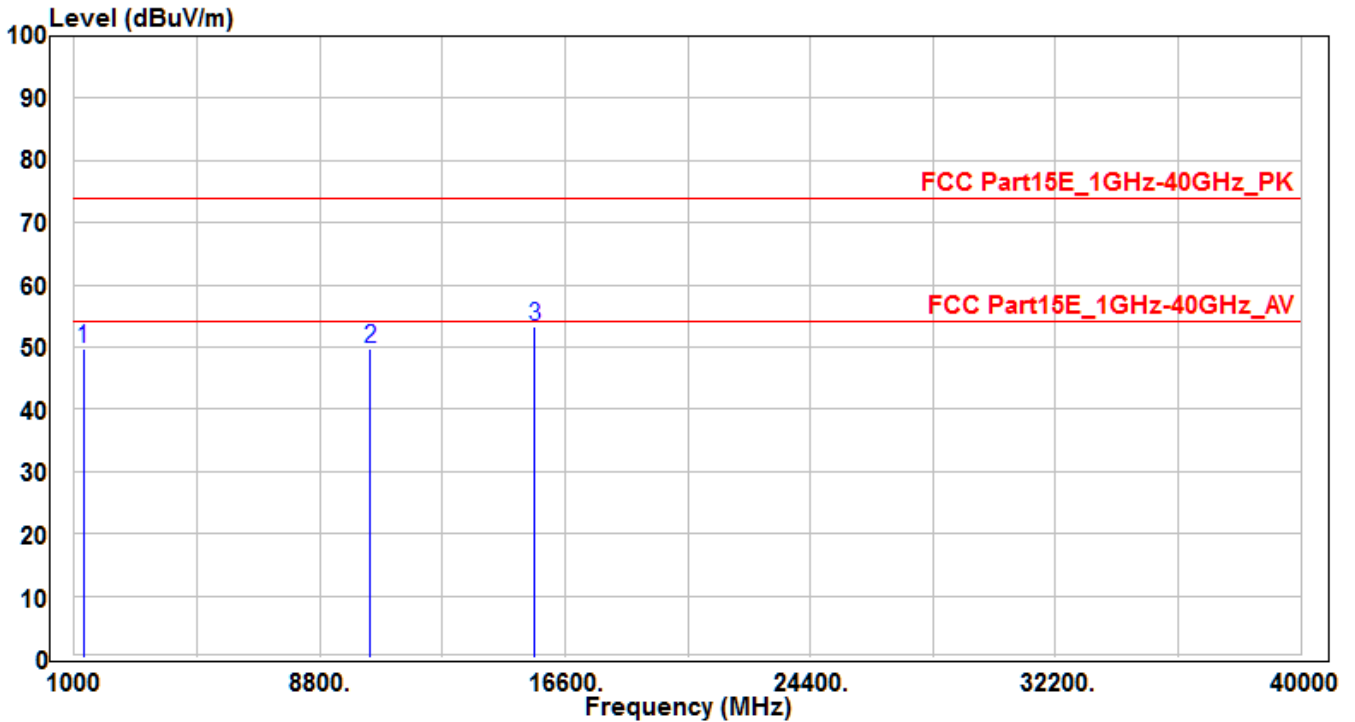

No	Frequency (MHz)	Reading (dBuV)	C.F (dB)	Measurement (dBuV/m)	Margin (dB)	Limit (dBuV/m)	Height (cm)	Angle (deg)	Remark (QP/PK/AV)
1	1295.65	56.51	-6.82	49.69	-24.31	74	150	400	Peak
2	10420	32.82	16.96	49.78	-24.22	74	150	400	Peak
3	* 15630	32.39	20.88	53.27	-20.73	74	150	400	Peak

Note : The EUT Power by Notebook PC

1. " * " means this data is the worst emission level.
2. .C.F (Correction Factor) = Antenna Factor (dB)+ Cable Loss (dB) – Preamplifier(dB).
3. Measurement (dBuV/m) = Reading(dBuV) + C.F (Correction Factor).

EUT	WIFI USB DONGLE	Test Date	2017/12/25
Factor	BBHA 9120D (1GHz~18GHz)	Temp. / Humidity	25°C / 60%
Polarity	Horizontal	Site / Engineer	AC1 / Peter
Test Mode	MODE4 -CH155	Test Voltage	AC 120V/60Hz

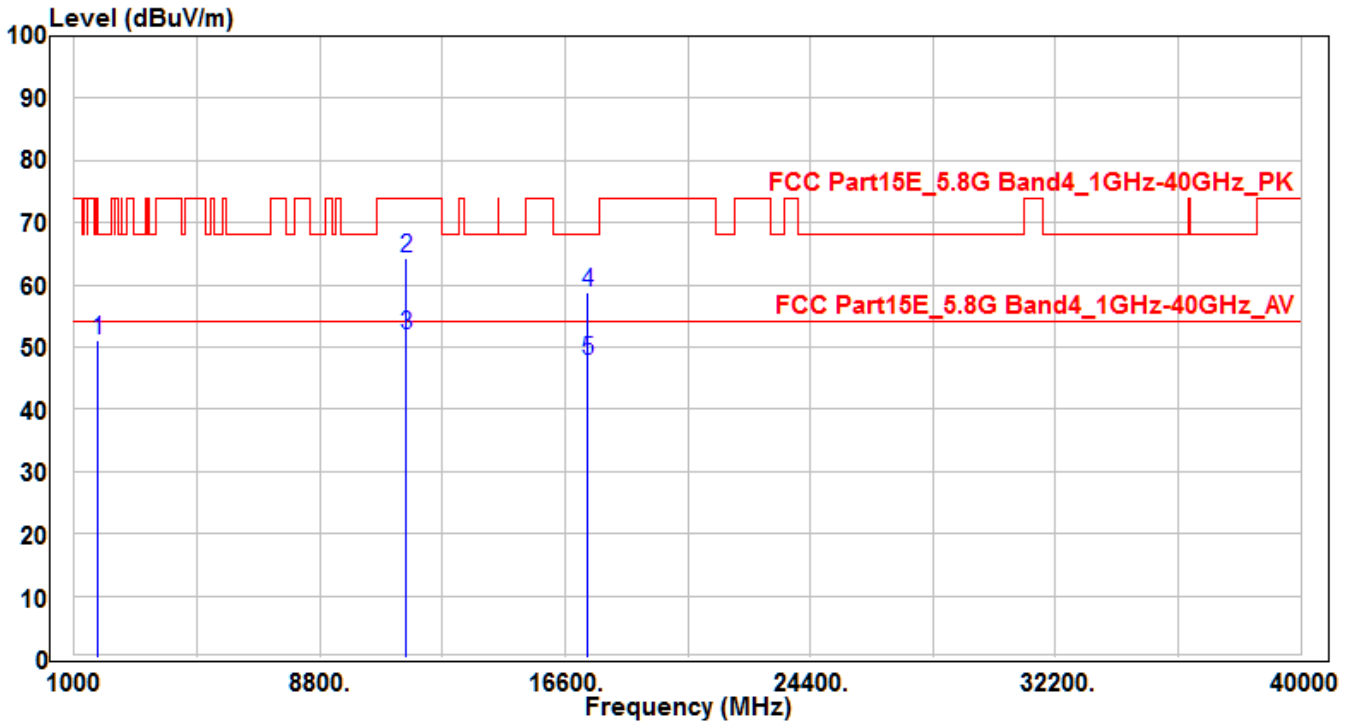

No	Frequency (MHz)	Reading (dBuV)	C.F (dB)	Measurement (dBuV/m)	Margin (dB)	Limit (dBuV/m)	Height (cm)	Angle (deg)	Remark (QP/PK/AV)
1	1754.58	56.49	-5.46	51.03	-17.17	68.2	150	400	Peak
2	*	45.94	18.27	64.21	-9.79	74	245	400	Peak
3	*	33.68	18.27	51.95	-2.05	54	245	400	Average
4	17325	31.24	27.6	58.84	-9.36	68.2	185	60	Peak
5	17325	20.1	27.6	47.7	-6.3	54	185	60	Average

Note : The EUT Power by Notebook PC

- "*" means this data is the worst emission level.
- .C.F (Correction Factor) = Antenna Factor (dB)+ Cable Loss (dB) – Preamplifier(dB).
- Measurement (dBuV/m) = Reading(dBuV) + C.F (Correction Factor).

EUT	WIFI USB DONGLE	Test Date	2017/12/25
Factor	BBHA 9120D (1GHz~18GHz)	Temp. / Humidity	25°C / 60%
Polarity	Vertical	Site / Engineer	AC1 / Peter
Test Mode	MODE4 -CH155	Test Voltage	AC 120V/60Hz

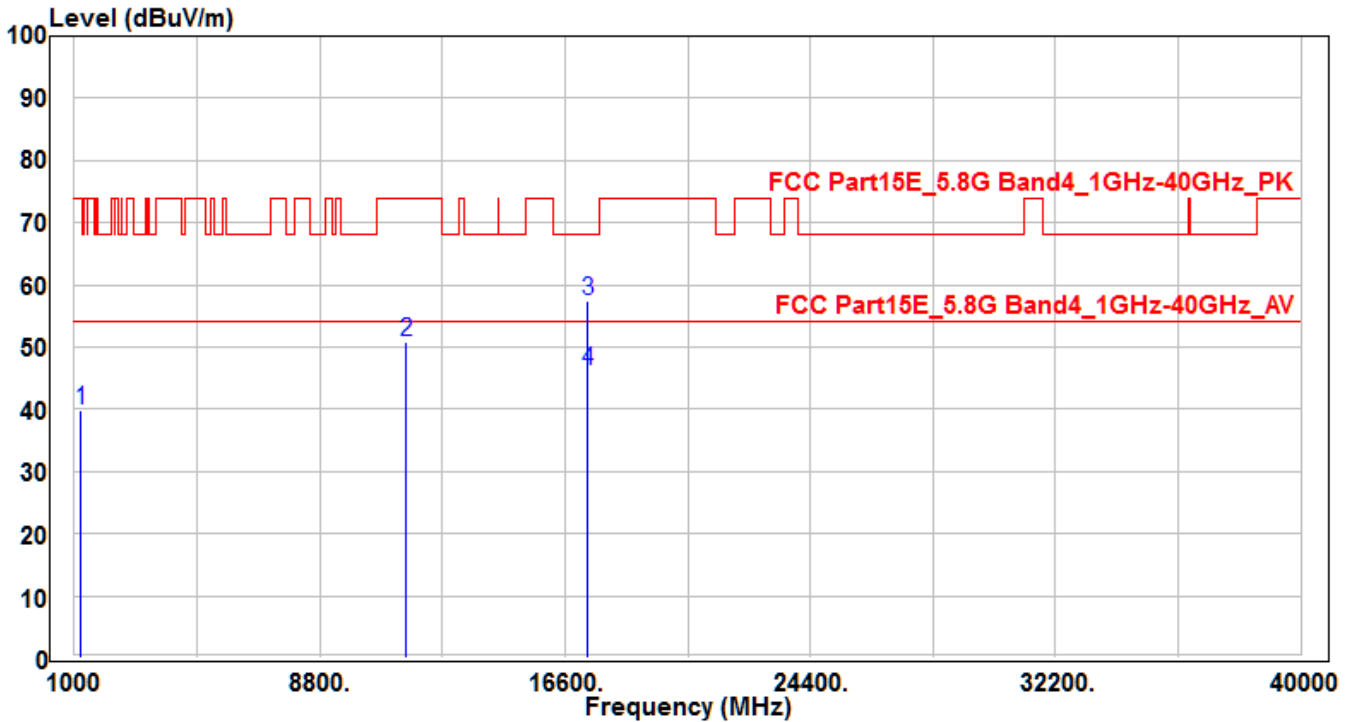

No	Frequency (MHz)	Reading (dBuV)	C.F (dB)	Measurement (dBuV/m)	Margin (dB)	Limit (dBuV/m)	Height (cm)	Angle (deg)	Remark (QP/PK/AV)
1	1202.4	46.8	-7.06	39.74	-34.26	74	150	400	Peak
2	11550	32.49	18.27	50.76	-23.24	74	150	400	Peak
3	* 17325	29.86	27.6	57.46	-10.74	68.2	160	-40	Peak
4	* 17325	18.56	27.6	46.16	-7.84	54	160	-40	Average

Note : The EUT Power by Notebook PC

1. " * " means this data is the worst emission level.
2. .C.F (Correction Factor) = Antenna Factor (dB)+ Cable Loss (dB) – Preamplifier(dB).
3. Measurement (dBuV/m) = Reading(dBuV) + C.F (Correction Factor).

7.8. Radiated Restricted Band Edge Measurement

7.8.1. Test Limit

For 15.205 requirement:

Radiated emissions which fall in the restricted bands, as defined in Section 15.205(a) of FCC part 15, must also comply with the radiated emission limits specified in Section 15.209(a).

Frequency (MHz)	Frequency (MHz)	Frequency (MHz)	Frequency (GHz)
0.090 - 0.110	16.42 - 16.423	399.9 - 410	4.5 - 5.15
¹ 0.495 - 0.505	16.69475 - 16.69525	608 - 614	5.35 - 5.46
2.1735 - 2.1905	16.80425 - 16.80475	960 - 1240	7.25 - 7.75
4.125 - 4.128	25.5 - 25.67	1300 - 1427	8.25 - 8.5
4.17725 - 4.17775	37.5 - 38.25	1435 - 1626.5	9.0 - 9.2
4.20725 - 4.20775	73 - 74.6	1645.5 - 1646.5	9.3 - 9.5
6.215 - 6.218	74.8 - 75.2	1660 - 1710	10.6 - 12.7
6.26775 - 6.26825	108 - 121.94	1718.8 - 1722.2	13.25 - 13.4
6.31175 - 6.31225	123 - 138	2200 - 2300	14.47 - 14.5
8.291 - 8.294	149.9 - 150.05	2310 - 2390	15.35 - 16.2
8.362 - 8.366	156.52475 - 156.525	2483.5 - 2500	17.7 - 21.4
8.37625 - 8.38675	156.7 - 156.9	2690 - 2900	22.01 - 23.12
8.41425 - 8.41475	162.0125 - 167.17	3260 - 3267	23.6 - 24.0
12.29 - 12.293	167.72 - 173.2	3332 - 3339	31.2 - 31.8
12.51975 - 12.52025	240 - 285	3345.8 - 3358	36.43 - 36.5
12.57675 - 12.57725	322 - 335.4	3600 - 4400	(²)
13.36 - 13.41	--	--	--

For 15.407(b) requirement:

For transmitters operating in the 5.15-5.25 GHz band: All emissions outside of the 5.15-5.35 GHz band shall not exceed an e.i.r.p. of -27 dBm/MHz.

For transmitters operating in the 5.25-5.35 GHz band: All emissions outside of the 5.15-5.35 GHz band shall not exceed an e.i.r.p. of -27 dBm/MHz.

For transmitters operating in the 5.47-5.725 GHz band: All emissions outside of the 5.47-5.725 GHz band shall not exceed an e.i.r.p. of -27 dBm/MHz.

For FCC transmitters operating in the 5.725-5.85 GHz band: All emissions shall be limited to a level of -27 dBm/MHz at 75 MHz or more above or below the band edge increasing linearly to 10 dBm/MHz at 25 MHz above or below the band edge, and from 25 MHz above or below the band edge increasing linearly to a level of 15.6 dBm/MHz at 5 MHz above or below the band edge, and from 5 MHz above or below the band edge increasing linearly to a level of 27 dBm/MHz at the band edge.

For IC transmitters operating in the 5.725-5.85 GHz band: All emissions within the frequency range from the band edge to 10 MHz above or below the band edge shall not exceed an e.i.r.p. of -17 dBm/MHz; for frequencies 10 MHz or greater above or below the band edge, emissions shall not exceed an e.i.r.p. of -27 dBm/MHz.

Refer to KDB 789033 D02v02r01 G)2)c), as specified in § 15.407(b), emissions above 1000 MHz that are outside of the restricted bands are subject to a maximum emission limit of -27 dBm/MHz (or -17 dBm/MHz as specified in § 15.407(b)(4)). However, an out-of-band emission that complies with both the peak and average limits of § 15.209 is not required to satisfy the -27 dBm/MHz or -17 dBm/MHz maximum emission limit.

All out of band emissions appearing in a restricted band as specified in Section 15.205 of the Title 47 CFR must not exceed the limits shown in Table per Section 15.209.

FCC-Radiated emission limits; general requirements.

FCC Part 15 Subpart C Paragraph 15.209		
Frequency [MHz]	Field Strength [V/m]	Measured Distance [Meters]
0.009 ~ 0.490	2400/F (kHz)	300
0.490 ~ 1.705	24000/F (kHz)	30
1.705 ~ 30	30	30
30 ~ 88	100	3
88 ~ 216	150	3
216 ~ 960	200	3
Above 960	500	3

7.8.2. Test Result

EUT	WIFI USB DONGLE	Test Date	2017/12/25
Factor	BBHA 9120D (1GHz~18GHz)	Temp. / Humidity	21°C / 57%
Polarity	Horizontal	Site / Engineer	AC1 / Peter
Test Mode	MODE1-CH36	Test Voltage	AC 120V/60Hz

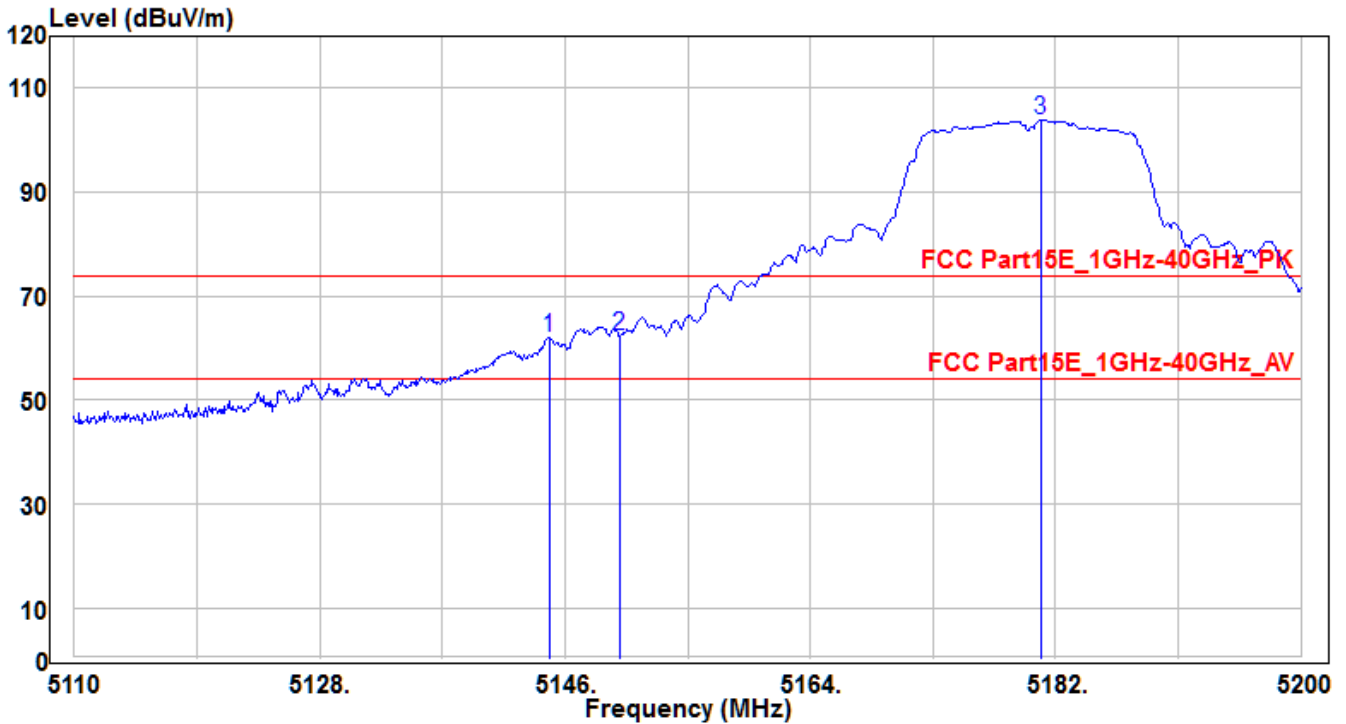

No	Frequency (MHz)	Reading (dBUV)	C.F (dB)	Measurement (dBUV/m)	Margin (dB)	Limit (dBUV/m)	Height (cm)	Angle (deg)	Remark (QP/PK/AV)
1	5144.83	58.56	3.34	61.9	-12.1	74	155	335	Peak
2	* 5150	59.11	3.36	62.47	-11.53	74	155	335	Peak
3	5180.92	100.32	3.42	103.74	29.74	74	155	335	Peak

Note : The EUT Power by Notebook PC

- " * " means this data is the worst emission level.
- C.F (Correction Factor) = Antenna Factor (dB)+ Cable Loss (dB) – Preamplifier(dB).
- Measurement (dBUV/m) = Reading(dBUV) + C.F (Correction Factor).

EUT	WIFI USB DONGLE	Test Date	2017/12/25
Factor	BBHA 9120D (1GHz~18GHz)	Temp. / Humidity	21°C / 57%
Polarity	Horizontal	Site / Engineer	AC1 / Peter
Test Mode	MODE1-CH36	Test Voltage	AC 120V/60Hz

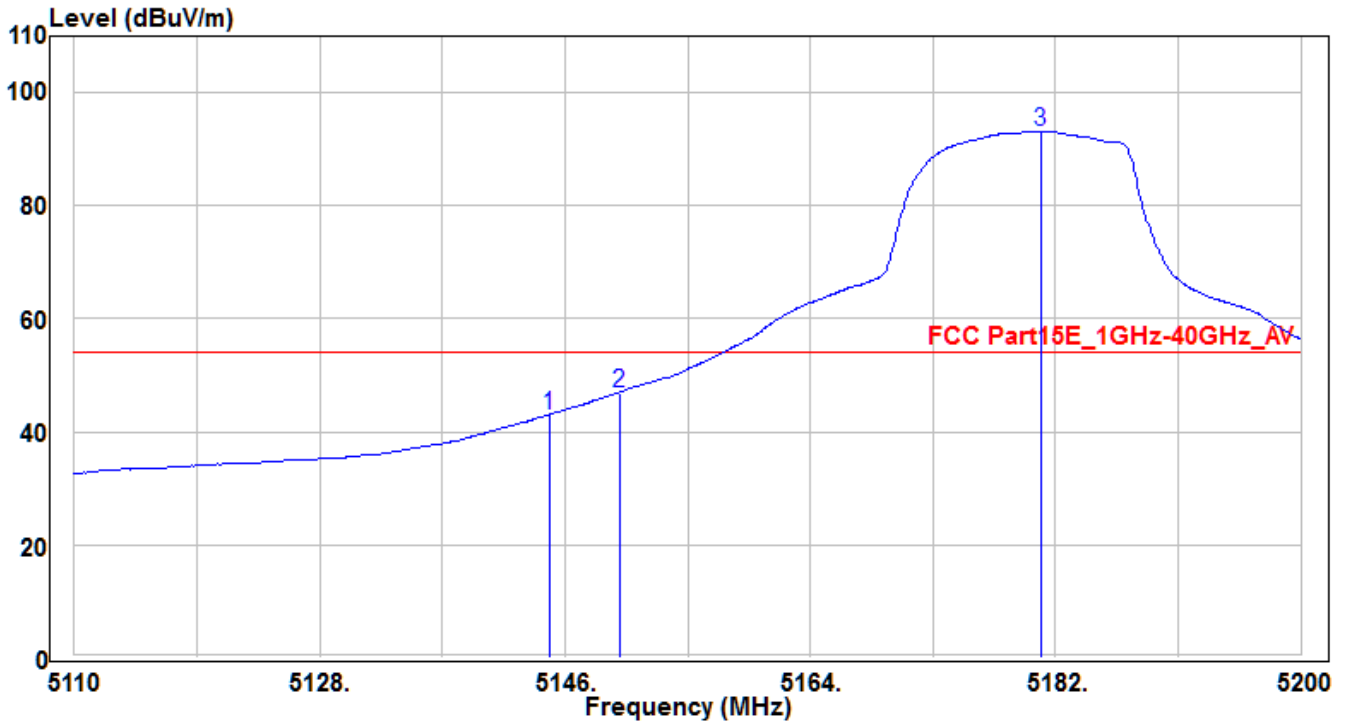

No	Frequency (MHz)	Reading (dBuV)	C.F (dB)	Measurement (dBuV/m)	Margin (dB)	Limit (dBuV/m)	Height (cm)	Angle (deg)	Remark (QP/PK/AV)
1	5144.83	39.7	3.34	43.04	-10.96	54	155	335	Average
2	* 5150	43.6	3.36	46.96	-7.04	54	155	335	Average
3	5180.92	89.79	3.42	93.21	39.21	54	155	335	Average

Note : The EUT Power by Notebook PC

1. " * " means this data is the worst emission level.
2. C.F (Correction Factor) = Antenna Factor (dB)+ Cable Loss (dB) – Preamplifier(dB).
3. Measurement (dBuV/m) = Reading(dBuV) + C.F (Correction Factor).

EUT	WIFI USB DONGLE	Test Date	2017/12/25
Factor	BBHA 9120D (1GHz~18GHz)	Temp. / Humidity	21°C / 57%
Polarity	Vertical	Site / Engineer	AC1 / Peter
Test Mode	MODE1-CH36	Test Voltage	AC 120V/60Hz

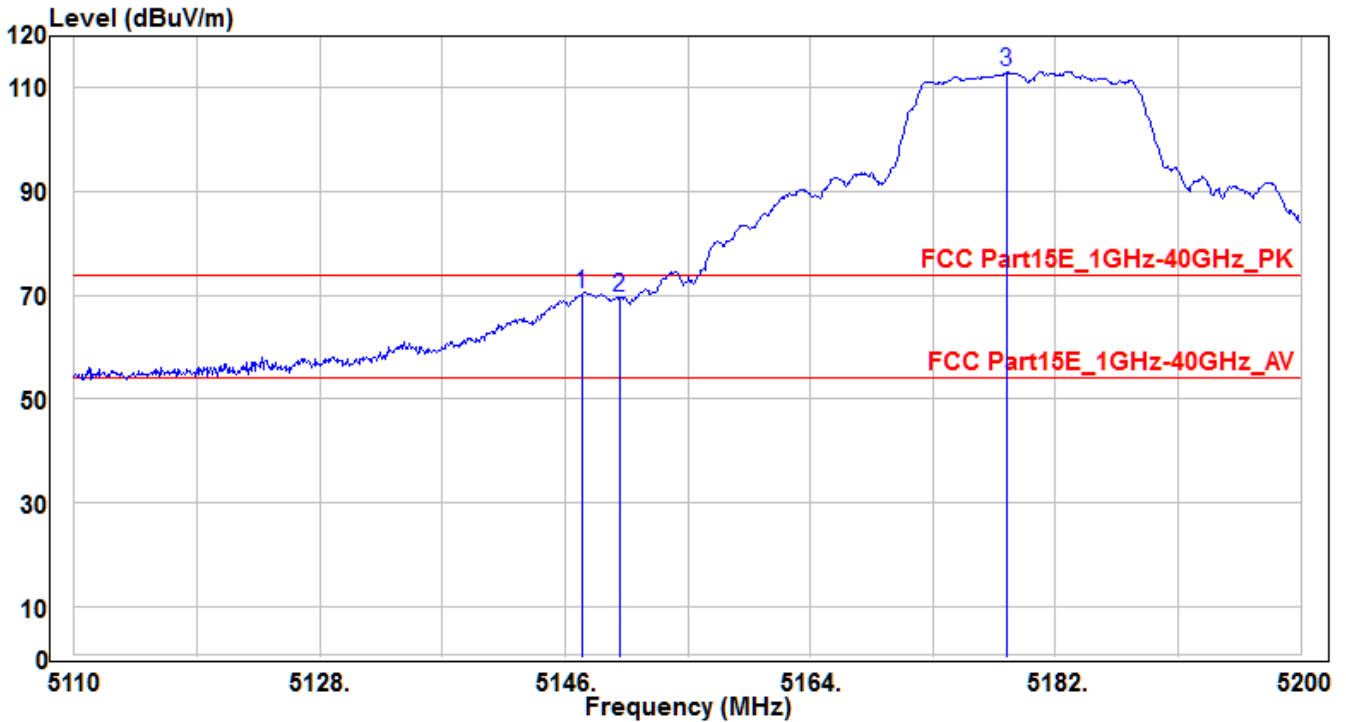

No	Frequency (MHz)	Reading (dBuV)	C.F (dB)	Measurement (dBuV/m)	Margin (dB)	Limit (dBuV/m)	Height (cm)	Angle (deg)	Remark (QP/PK/AV)	
1	*	5147.26	66.81	3.35	70.16	-3.84	74	170	275	Peak
2		5150	66.23	3.36	69.59	-4.41	74	170	275	Peak
3		5178.4	109.62	3.42	113.04	39.04	74	170	275	Peak

Note : The EUT Power by Notebook PC

- "*" means this data is the worst emission level.
- C.F (Correction Factor) = Antenna Factor (dB)+ Cable Loss (dB) – Preamplifier(dB).
- Measurement (dBuV/m) = Reading(dBuV) + C.F (Correction Factor).

EUT	WIFI USB DONGLE	Test Date	2017/12/25
Factor	BBHA 9120D (1GHz~18GHz)	Temp. / Humidity	21°C / 57%
Polarity	Vertical	Site / Engineer	AC1 / Peter
Test Mode	MODE1-CH36	Test Voltage	AC 120V/60Hz

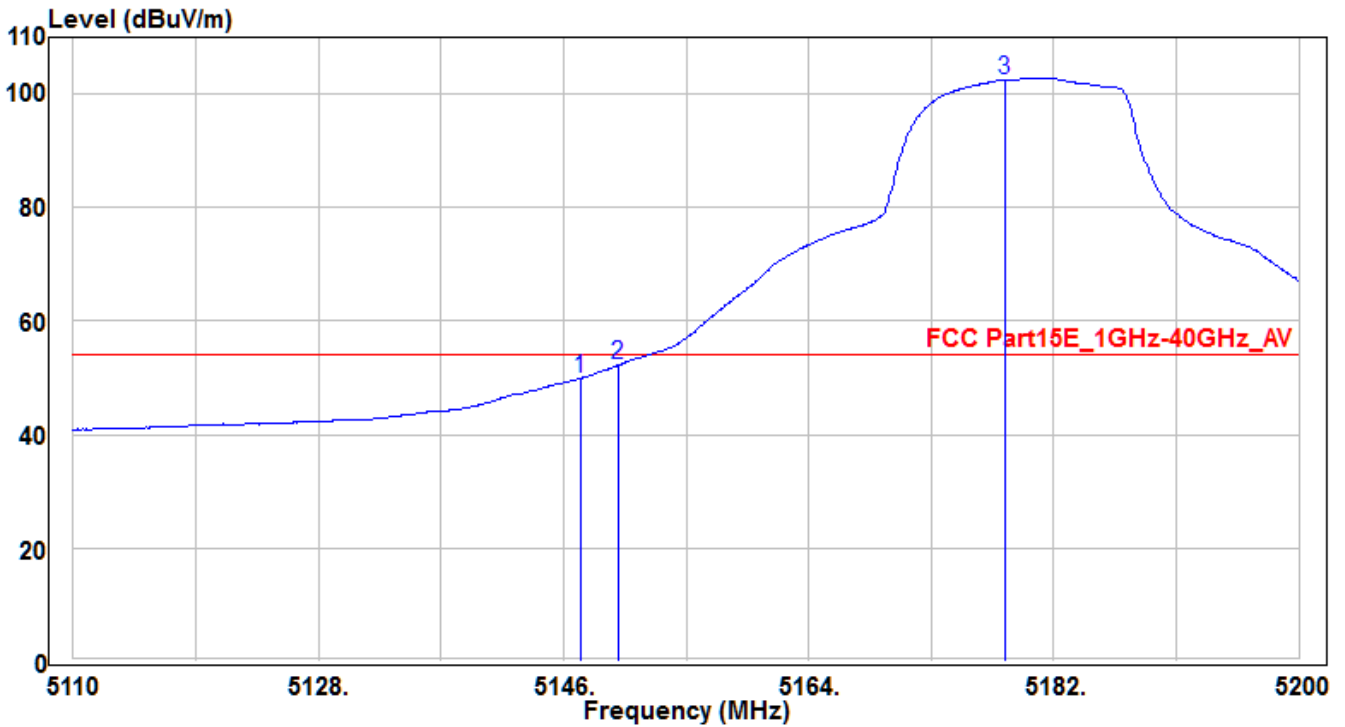

No	Frequency (MHz)	Reading (dBuV)	C.F (dB)	Measurement (dBuV/m)	Margin (dB)	Limit (dBuV/m)	Height (cm)	Angle (deg)	Remark (QP/PK/AV)
1	5147.26	46.59	3.35	49.94	-4.06	54	170	275	Average
2	* 5150	48.81	3.36	52.17	-1.83	54	170	275	Average
3	5178.4	99.1	3.42	102.52	48.52	54	170	275	Average

Note : The EUT Power by Notebook PC

1. " * " means this data is the worst emission level.
2. C.F (Correction Factor) = Antenna Factor (dB)+ Cable Loss (dB) – Preamplifier(dB).
3. Measurement (dBuV/m) = Reading(dBuV) + C.F (Correction Factor).

EUT	WIFI USB DONGLE	Test Date	2017/12/25
Factor	BBHA 9120D (1GHz~18GHz)	Temp. / Humidity	21°C / 57%
Polarity	Horizontal	Site / Engineer	AC1 / Peter
Test Mode	MODE1-CH149	Test Voltage	AC 120V/60Hz

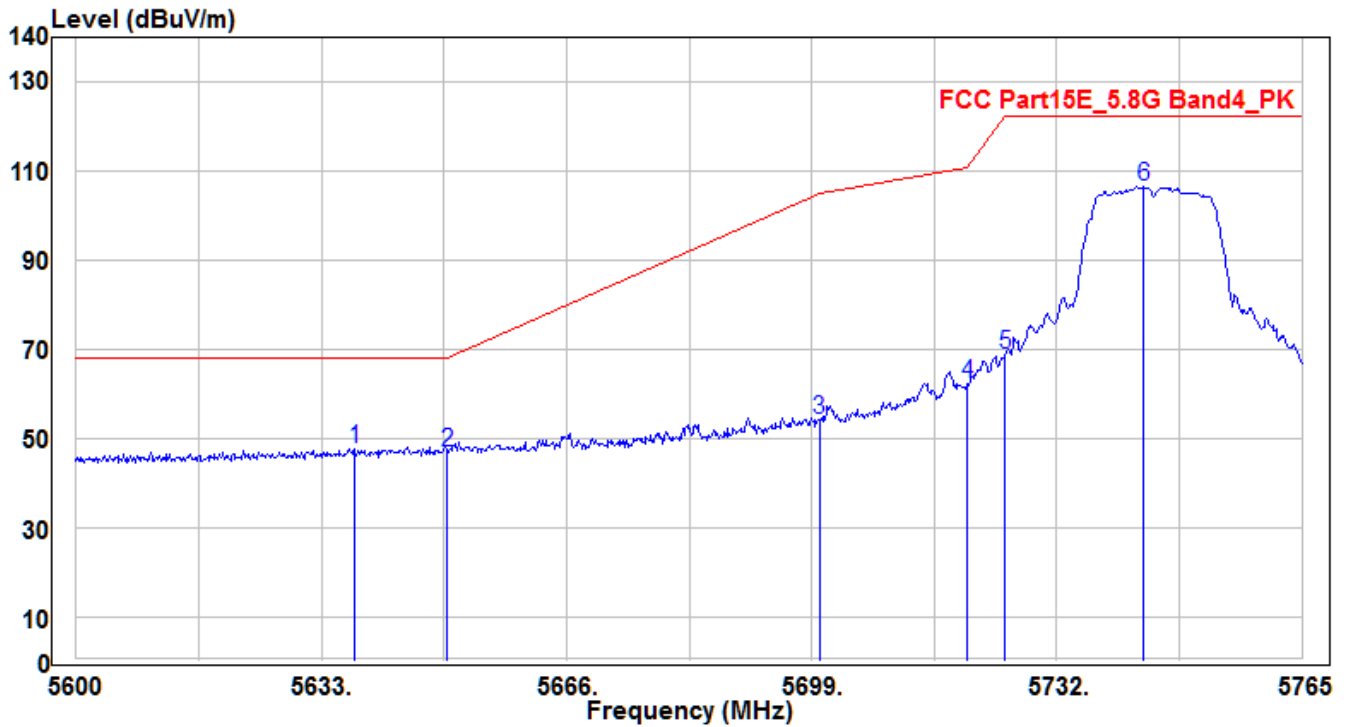

No	Frequency (MHz)	Reading (dBuV)	C.F (dB)	Measurement (dBuV/m)	Margin (dB)	Limit (dBuV/m)	Height (cm)	Angle (deg)	Remark (QP/PK/AV)
1	5637.455	43.1	4.6	47.7	-20.5	68.2	155	235	Peak
2	5650	42.45	4.65	47.1	-21.1	68.2	155	235	Peak
3	5700	49.31	4.84	54.15	-51.05	105.2	155	235	Peak
4	5720	57.24	4.91	62.15	-48.65	110.8	155	235	Peak
5	5725	63.84	4.93	68.77	-53.43	122.2	155	235	Peak
6	* 5743.715	101.39	5	106.39	-15.81	122.2	155	235	Peak

Note : The EUT Power by Notebook PC

1. " * " means this data is the worst emission level.
2. C.F (Correction Factor) = Antenna Factor (dB)+ Cable Loss (dB) – Preamplifier(dB).
3. Measurement (dBuV/m) = Reading(dBuV) + C.F (Correction Factor).

EUT	WIFI USB DONGLE	Test Date	2017/12/25
Factor	BBHA 9120D (1GHz~18GHz)	Temp. / Humidity	21°C / 57%
Polarity	Vertical	Site / Engineer	AC1 / Peter
Test Mode	MODE1-CH149	Test Voltage	AC 120V/60Hz

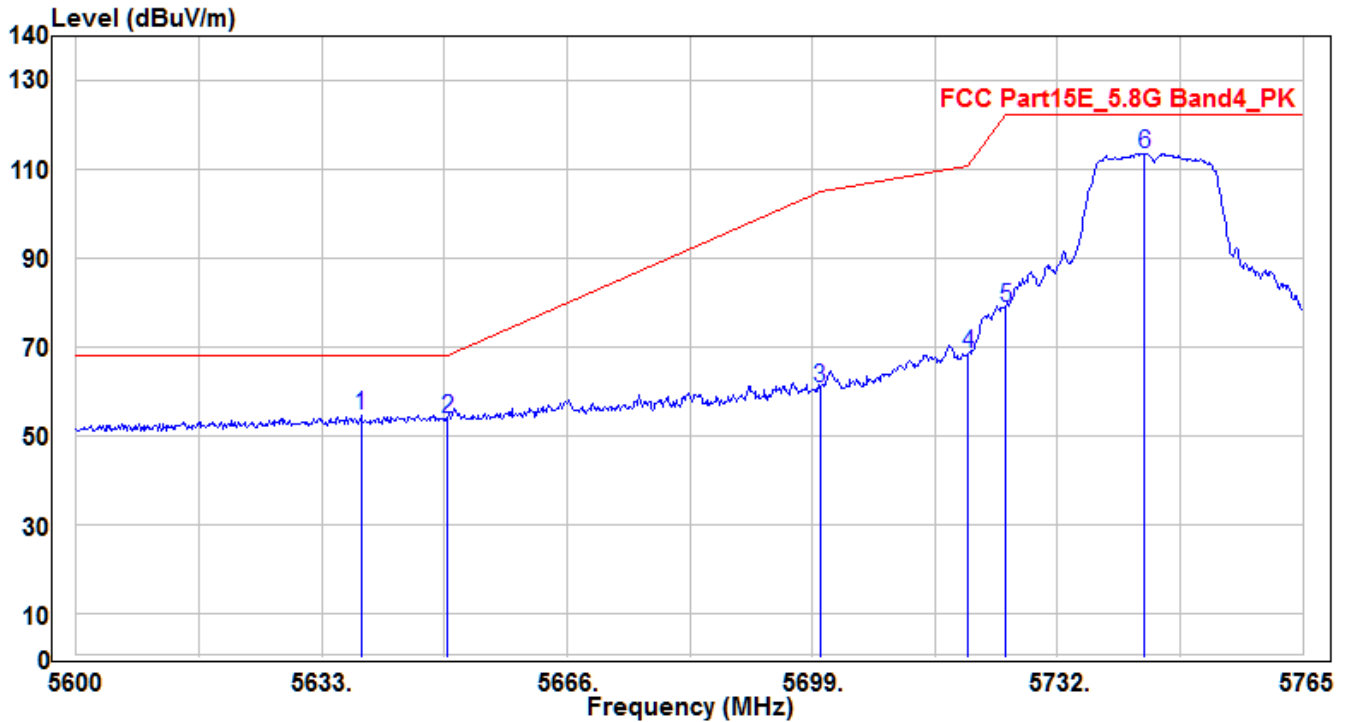

No	Frequency (MHz)	Reading (dBUV)	C.F (dB)	Measurement (dBUV/m)	Margin (dB)	Limit (dBUV/m)	Height (cm)	Angle (deg)	Remark (QP/PK/AV)
1	5638.28	50.05	4.6	54.65	-13.55	68.2	150	295	Peak
2	5650	49.34	4.65	53.99	-14.21	68.2	150	295	Peak
3	5700	56.05	4.84	60.89	-44.31	105.2	150	295	Peak
4	5720	63.41	4.91	68.32	-42.48	110.8	150	295	Peak
5	5725	73.86	4.93	78.79	-43.41	122.2	150	295	Peak
6	* 5743.715	108.66	5	113.66	-8.54	122.2	150	295	Peak

Note : The EUT Power by Notebook PC

1. " * " means this data is the worst emission level.
2. C.F (Correction Factor) = Antenna Factor (dB)+ Cable Loss (dB) – Preamplifier(dB).
3. Measurement (dBUV/m) = Reading(dBUV) + C.F (Correction Factor).

EUT	WIFI USB DONGLE	Test Date	2017/12/25
Factor	BBHA 9120D (1GHz~18GHz)	Temp. / Humidity	21°C / 57%
Polarity	Horizontal	Site / Engineer	AC1 / Peter
Test Mode	MODE1-CH165	Test Voltage	AC 120V/60Hz

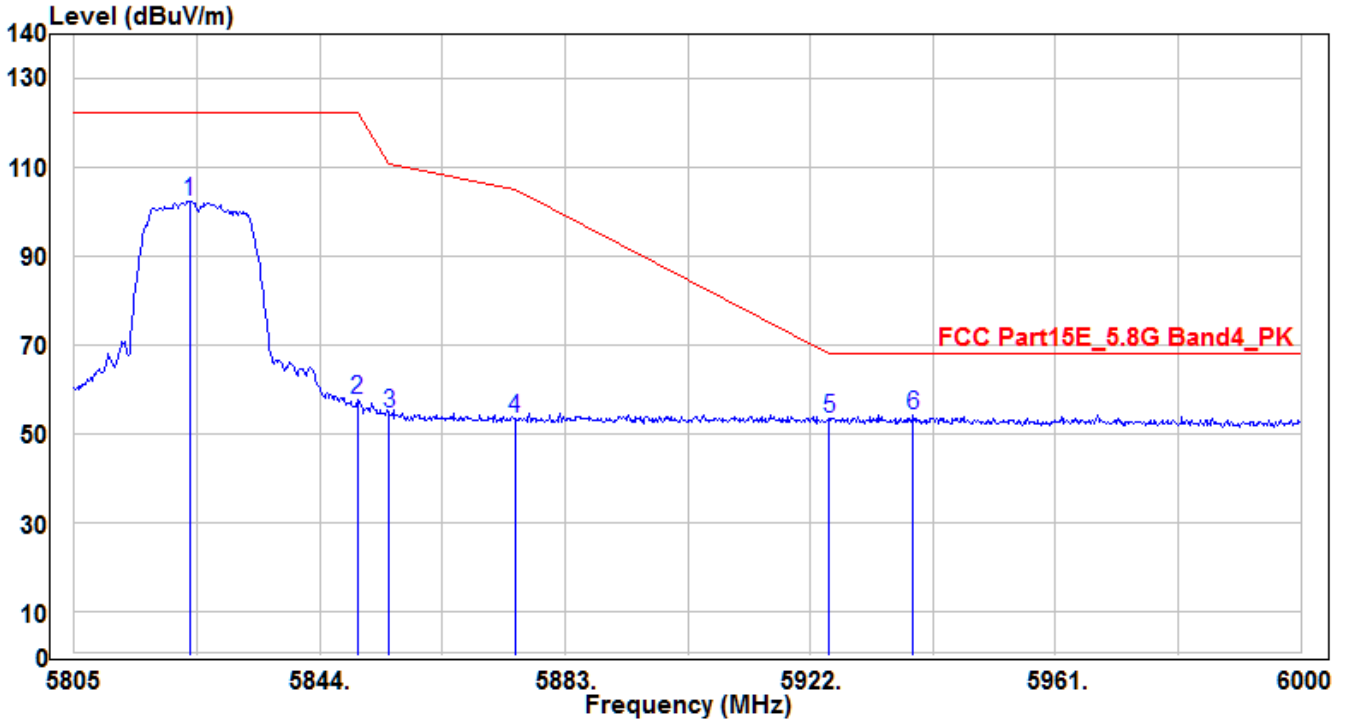

No	Frequency (MHz)	Reading (dBUV)	C.F (dB)	Measurement (dBUV/m)	Margin (dB)	Limit (dBUV/m)	Height (cm)	Angle (deg)	Remark (QP/PK/AV)
1	5823.33	97.09	5.31	102.4	-19.8	122.2	150	165	Peak
2	5850	52.33	5.41	57.74	-64.46	122.2	150	165	Peak
3	5855	49.02	5.44	54.46	-56.34	110.8	150	165	Peak
4	5875	47.88	5.51	53.39	-51.81	105.2	150	165	Peak
5	5925	47.89	5.7	53.59	-14.61	68.2	150	165	Peak
6	* 5938.38	48.5	5.75	54.25	-13.95	68.2	150	165	Peak

Note : The EUT Power by Notebook PC

1. " * " means this data is the worst emission level.
2. C.F (Correction Factor) = Antenna Factor (dB)+ Cable Loss (dB) – Preamplifier(dB).
3. Measurement (dBUV/m) = Reading(dBUV) + C.F (Correction Factor).

EUT	WIFI USB DONGLE	Test Date	2017/12/25
Factor	BBHA 9120D (1GHz~18GHz)	Temp. / Humidity	21°C / 57%
Polarity	Vertical	Site / Engineer	AC1 / Peter
Test Mode	MODE1-CH165	Test Voltage	AC 120V/60Hz

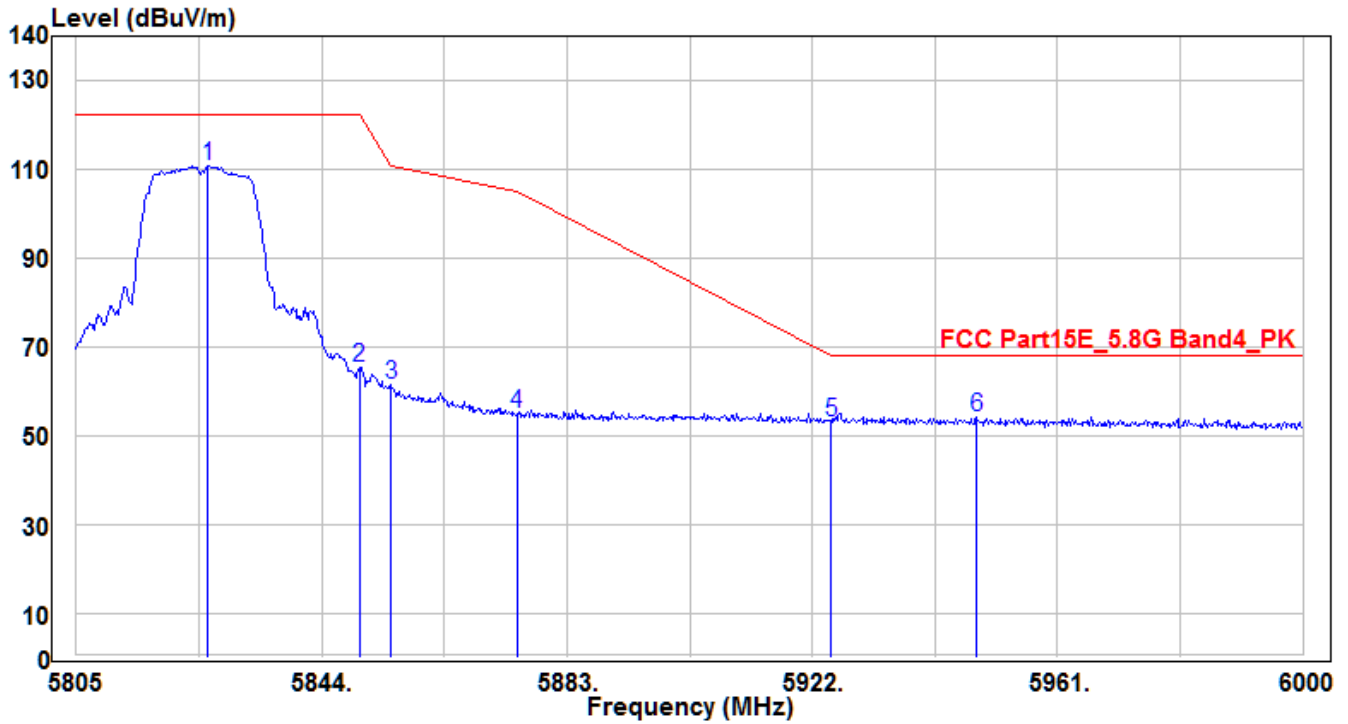

No	Frequency (MHz)	Reading (dBuV)	C.F (dB)	Measurement (dBuV/m)	Margin (dB)	Limit (dBuV/m)	Height (cm)	Angle (deg)	Remark (QP/PK/AV)	
1	*	5825.865	105.44	5.32	110.76	-11.44	122.2	160	245	Peak
2		5850	60.04	5.41	65.45	-56.75	122.2	160	245	Peak
3		5855	56.26	5.44	61.7	-49.1	110.8	160	245	Peak
4		5875	49.34	5.51	54.85	-50.35	105.2	160	245	Peak
5		5925	47.3	5.7	53	-15.2	68.2	160	245	Peak
6		5948.13	48.26	5.8	54.06	-14.14	68.2	160	245	Peak

Note : The EUT Power by Notebook PC

1. " * " means this data is the worst emission level.
2. C.F (Correction Factor) = Antenna Factor (dB)+ Cable Loss (dB) – Preamplifier(dB).
3. Measurement (dBuV/m) = Reading(dBuV) + C.F (Correction Factor).

EUT	WIFI USB DONGLE	Test Date	2017/12/25
Factor	BBHA 9120D (1GHz~18GHz)	Temp. / Humidity	21°C / 57%
Polarity	Horizontal	Site / Engineer	AC1 / Peter
Test Mode	MODE2-CH36	Test Voltage	AC 120V/60Hz

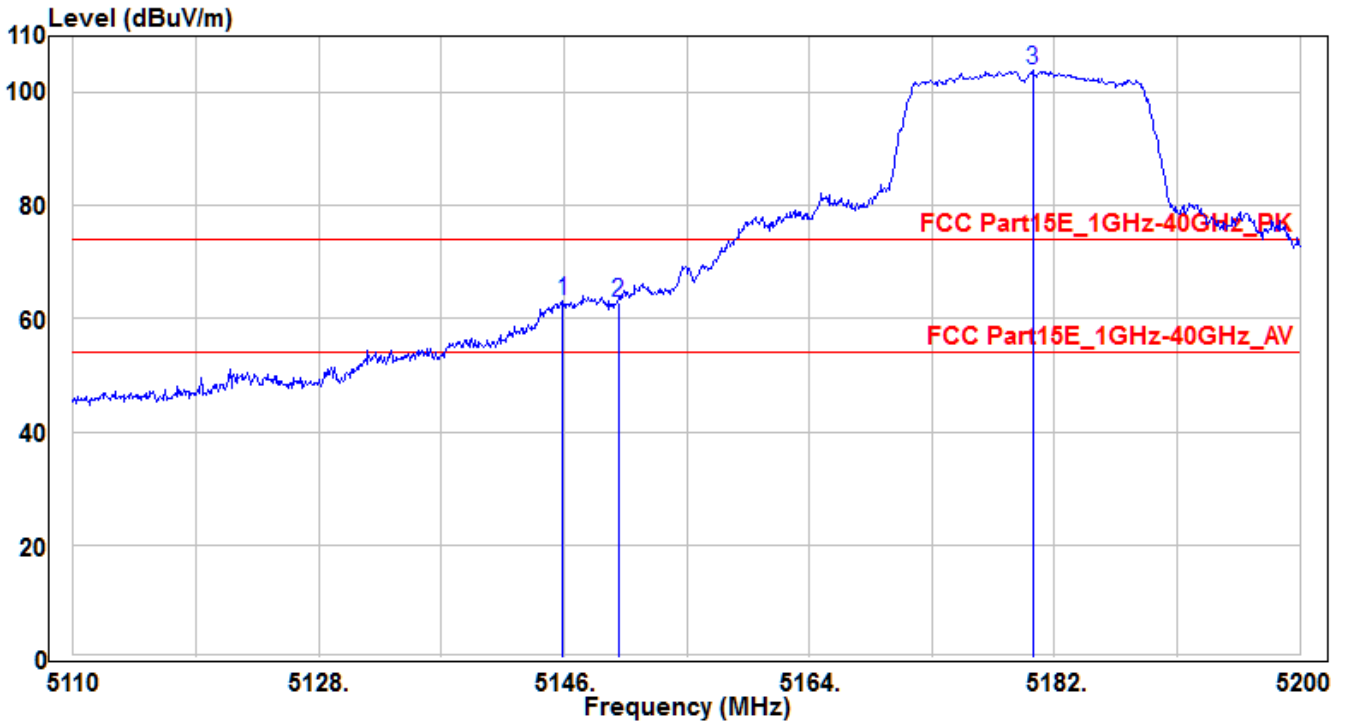

No	Frequency (MHz)	Reading (dBuV)	C.F (dB)	Measurement (dBuV/m)	Margin (dB)	Limit (dBuV/m)	Height (cm)	Angle (deg)	Remark (QP/PK/AV)
1	* 5145.91	59.93	3.34	63.27	-10.73	74	155	325	Peak
2	5150	59.47	3.36	62.83	-11.17	74	155	325	Peak
3	5180.38	100.47	3.42	103.89	29.89	74	155	325	Peak

Note : The EUT Power by Notebook PC

- "*" means this data is the worst emission level.
- C.F (Correction Factor) = Antenna Factor (dB)+ Cable Loss (dB) – Preamplifier(dB).
- Measurement (dBuV/m) = Reading(dBuV) + C.F (Correction Factor).

EUT	WIFI USB DONGLE	Test Date	2017/12/25
Factor	BBHA 9120D (1GHz~18GHz)	Temp. / Humidity	21°C / 57%
Polarity	Horizontal	Site / Engineer	AC1 / Peter
Test Mode	MODE2-CH36	Test Voltage	AC 120V/60Hz

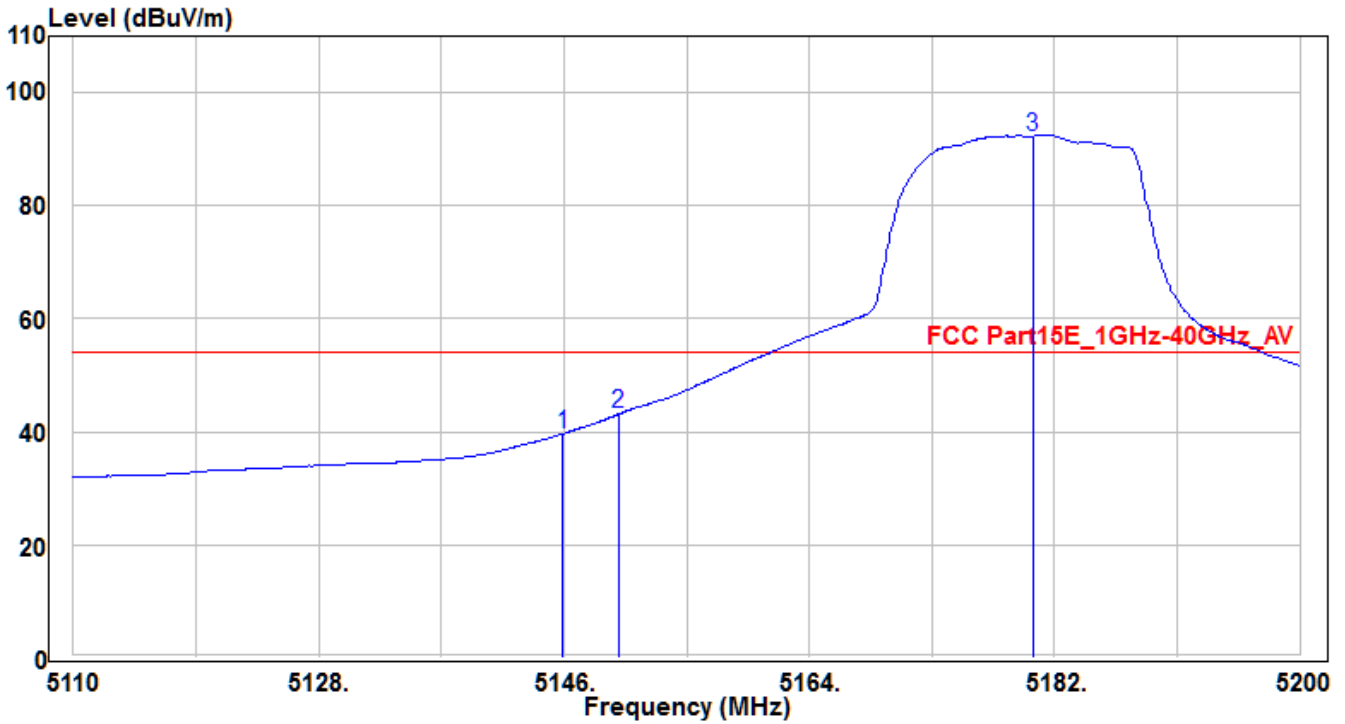

No	Frequency (MHz)	Reading (dBuV)	C.F (dB)	Measurement (dBuV/m)	Margin (dB)	Limit (dBuV/m)	Height (cm)	Angle (deg)	Remark (QP/PK/AV)
1	5145.91	36.33	3.34	39.67	-14.33	54	155	325	Average
2	* 5150	39.73	3.36	43.09	-10.91	54	155	325	Average
3	5180.38	88.9	3.42	92.32	38.32	54	155	325	Average

Note : The EUT Power by Notebook PC

1. " * " means this data is the worst emission level.
2. C.F (Correction Factor) = Antenna Factor (dB)+ Cable Loss (dB) – Preamplifier(dB).
3. Measurement (dBuV/m) = Reading(dBuV) + C.F (Correction Factor).

EUT	WIFI USB DONGLE	Test Date	2017/12/25
Factor	BBHA 9120D (1GHz~18GHz)	Temp. / Humidity	21°C / 57%
Polarity	Vertical	Site / Engineer	AC1 / Peter
Test Mode	MODE2-CH36	Test Voltage	AC 120V/60Hz

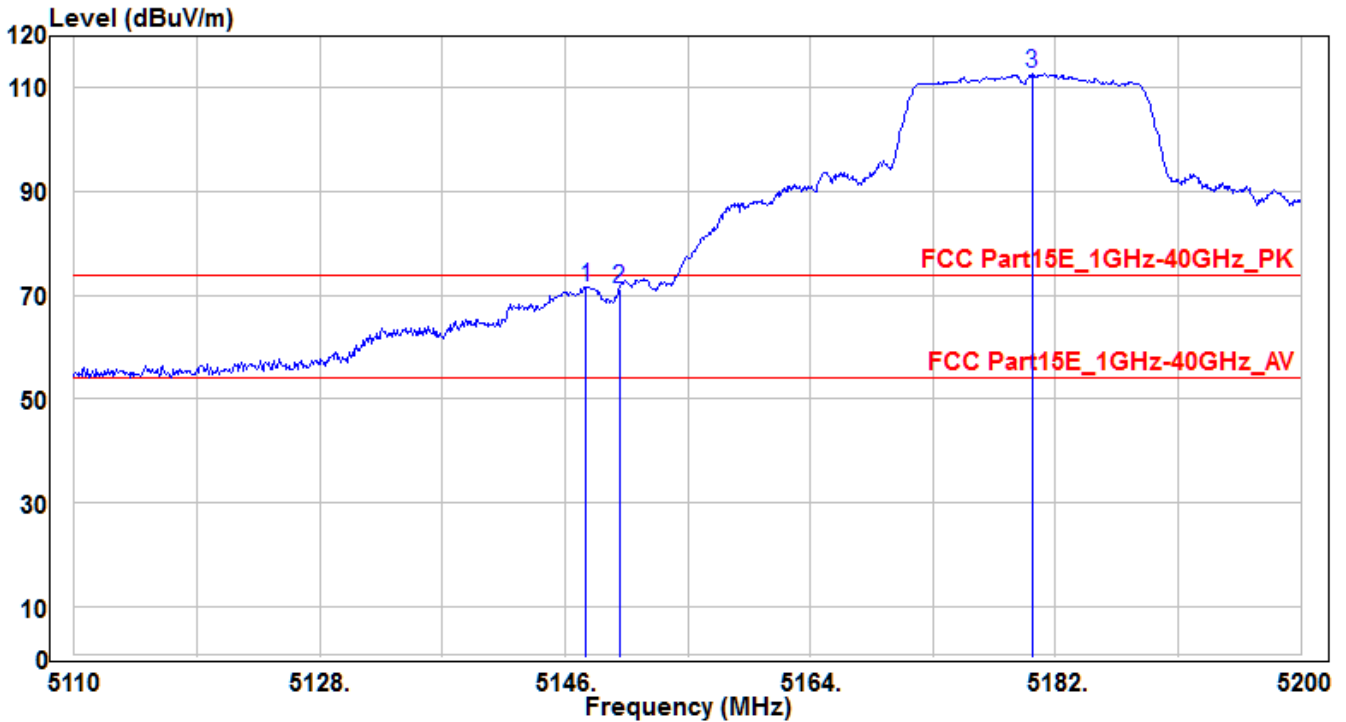

No	Frequency (MHz)	Reading (dBuV)	C.F (dB)	Measurement (dBuV/m)	Margin (dB)	Limit (dBuV/m)	Height (cm)	Angle (deg)	Remark (QP/PK/AV)
1	* 5147.53	68.2	3.35	71.55	-2.45	74	175	275	Peak
2	5150	67.79	3.36	71.15	-2.85	74	175	275	Peak
3	5180.29	109.38	3.42	112.8	38.8	74	175	275	Peak

Note : The EUT Power by Notebook PC

- "*" means this data is the worst emission level.
- C.F (Correction Factor) = Antenna Factor (dB)+ Cable Loss (dB) – Preamplifier(dB).
- Measurement (dBuV/m) = Reading(dBuV) + C.F (Correction Factor).

EUT	WIFI USB DONGLE	Test Date	2017/12/25
Factor	BBHA 9120D (1GHz~18GHz)	Temp. / Humidity	21°C / 57%
Polarity	Vertical	Site / Engineer	AC1 / Peter
Test Mode	MODE2-CH36	Test Voltage	AC 120V/60Hz

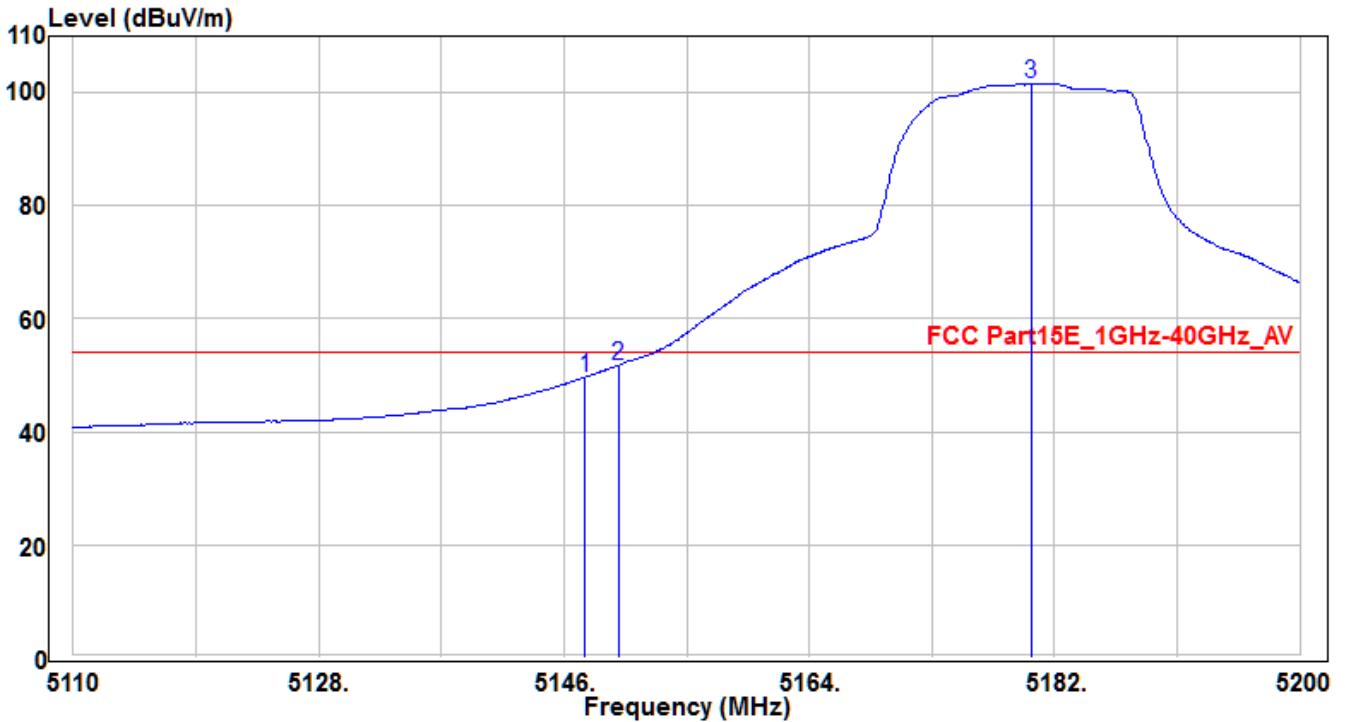

No	Frequency (MHz)	Reading (dBuV)	C.F (dB)	Measurement (dBuV/m)	Margin (dB)	Limit (dBuV/m)	Height (cm)	Angle (deg)	Remark (QP/PK/AV)
1	5147.53	46.32	3.35	49.67	-4.33	54	175	275	Average
2	* 5150	48.39	3.36	51.75	-2.25	54	175	275	Average
3	5180.29	98.06	3.42	101.48	47.48	54	175	275	Average

Note : The EUT Power by Notebook PC

1. " * " means this data is the worst emission level.
2. C.F (Correction Factor) = Antenna Factor (dB)+ Cable Loss (dB) – Preamplifier(dB).
3. Measurement (dBuV/m) = Reading(dBuV) + C.F (Correction Factor).

EUT	WIFI USB DONGLE	Test Date	2017/12/25
Factor	BBHA 9120D (1GHz~18GHz)	Temp. / Humidity	21°C / 57%
Polarity	Horizontal	Site / Engineer	AC1 / Peter
Test Mode	MODE2-CH149	Test Voltage	AC 120V/60Hz

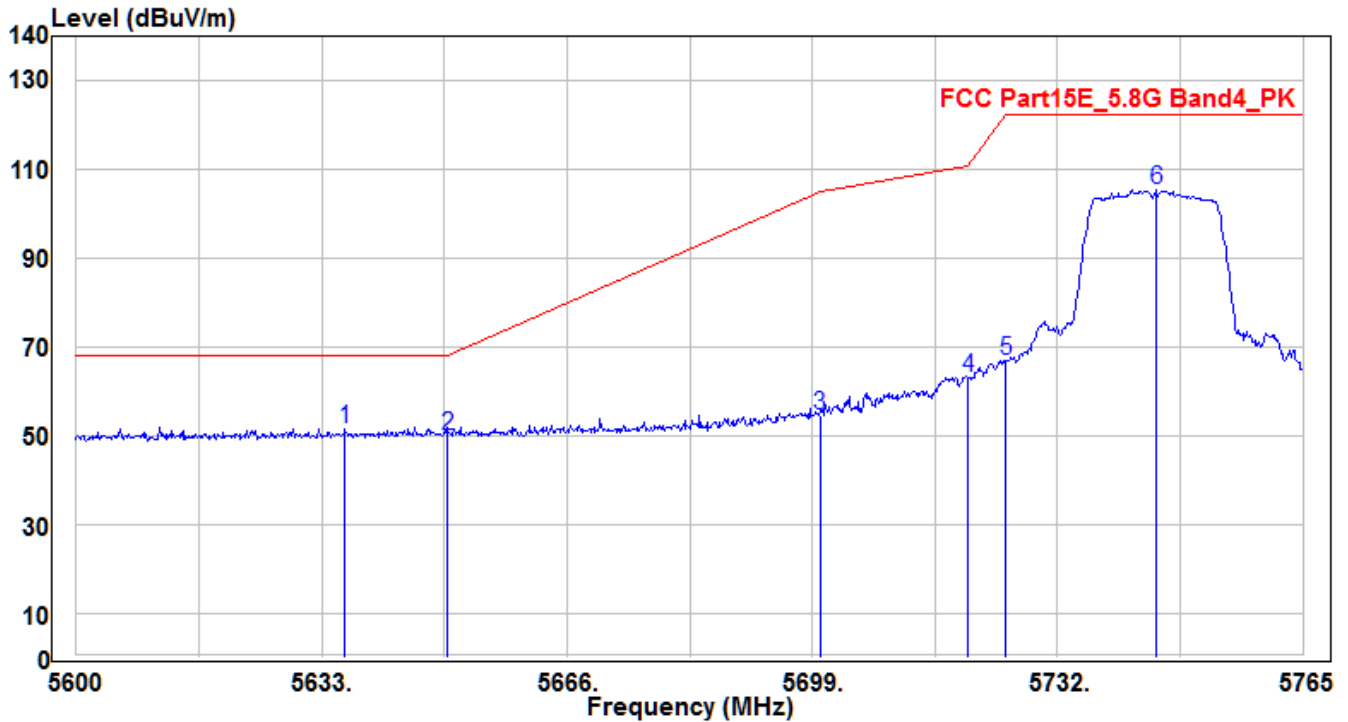

No	Frequency (MHz)	Reading (dBUV)	C.F (dB)	Measurement (dBUV/m)	Margin (dB)	Limit (dBUV/m)	Height (cm)	Angle (deg)	Remark (QP/PK/AV)
1	* 5636.135	46.93	4.59	51.52	-16.68	68.2	160	210	Peak
2	5650	45.52	4.65	50.17	-18.03	68.2	160	210	Peak
3	5700	49.68	4.84	54.52	-50.68	105.2	160	210	Peak
4	5720	58.16	4.91	63.07	-47.73	110.8	160	210	Peak
5	5725	62.19	4.93	67.12	-55.08	122.2	160	210	Peak
6	5745.365	100.26	5.01	105.27	-16.93	122.2	160	210	Peak

Note : The EUT Power by Notebook PC

- "*" means this data is the worst emission level.
- C.F (Correction Factor) = Antenna Factor (dB)+ Cable Loss (dB) – Preamplifier(dB).
- Measurement (dBUV/m) = Reading(dBUV) + C.F (Correction Factor).

EUT	WIFI USB DONGLE	Test Date	2017/12/25
Factor	BBHA 9120D (1GHz~18GHz)	Temp. / Humidity	21°C / 57%
Polarity	Vertical	Site / Engineer	AC1 / Peter
Test Mode	MODE2-CH149	Test Voltage	AC 120V/60Hz

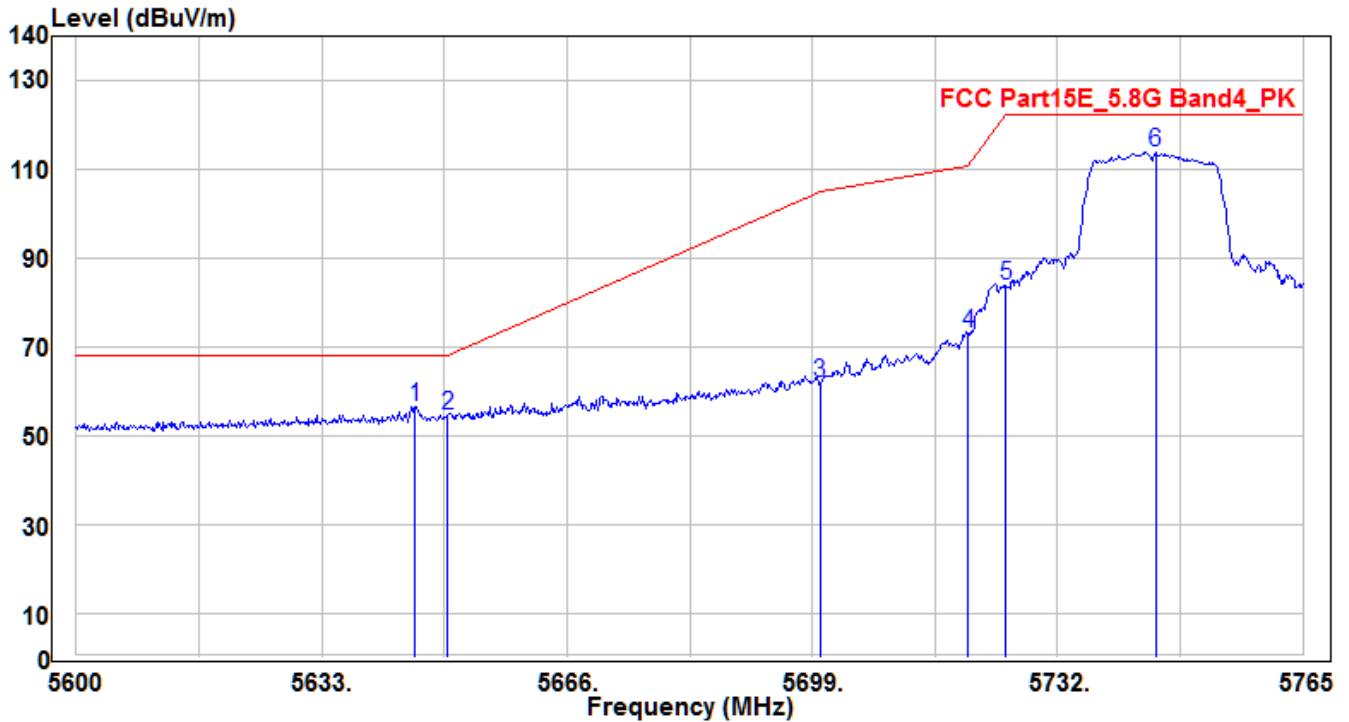

No	Frequency (MHz)	Reading (dBuV)	C.F (dB)	Measurement (dBuV/m)	Margin (dB)	Limit (dBuV/m)	Height (cm)	Angle (deg)	Remark (QP/PK/AV)
1	5645.54	51.96	4.62	56.58	-11.62	68.2	190	210	Peak
2	5650	50.01	4.65	54.66	-13.54	68.2	190	210	Peak
3	5700	57.15	4.84	61.99	-43.21	105.2	190	210	Peak
4	5720	68.18	4.91	73.09	-37.71	110.8	190	210	Peak
5	5725	78.98	4.93	83.91	-38.29	122.2	190	210	Peak
6	* 5745.2	108.83	5.01	113.84	-8.36	122.2	190	210	Peak

Note : The EUT Power by Notebook PC

1. " * " means this data is the worst emission level.
2. C.F (Correction Factor) = Antenna Factor (dB)+ Cable Loss (dB) – Preamplifier(dB).
3. Measurement (dBuV/m) = Reading(dBuV) + C.F (Correction Factor).

EUT	WIFI USB DONGLE	Test Date	2017/12/25
Factor	BBHA 9120D (1GHz~18GHz)	Temp. / Humidity	21°C / 57%
Polarity	Horizontal	Site / Engineer	AC1 / Peter
Test Mode	MODE2-CH165	Test Voltage	AC 120V/60Hz

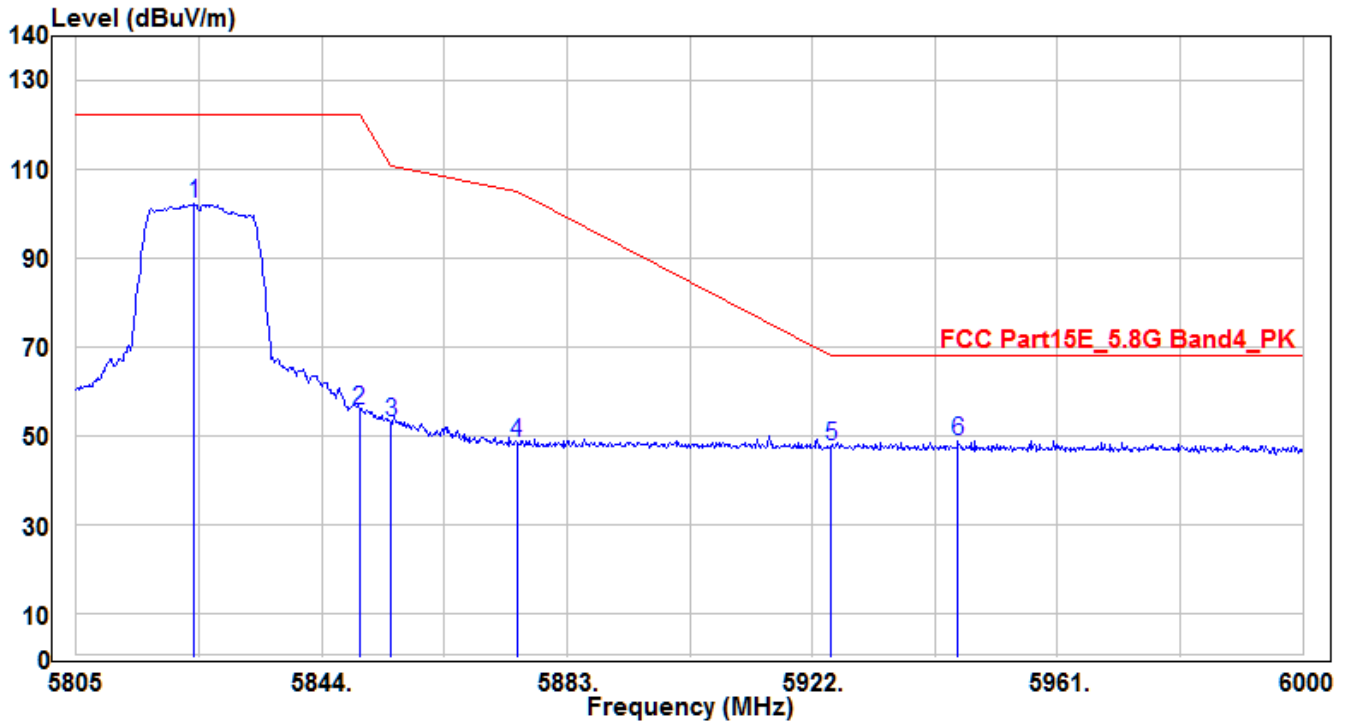

No	Frequency (MHz)	Reading (dBUV)	C.F (dB)	Measurement (dBUV/m)	Margin (dB)	Limit (dBUV/m)	Height (cm)	Angle (deg)	Remark (QP/PK/AV)
1	5823.72	96.92	5.31	102.23	-19.97	122.2	160	150	Peak
2	5850	50.2	5.41	55.61	-66.59	122.2	160	150	Peak
3	5855	47.74	5.44	53.18	-57.62	110.8	160	150	Peak
4	5875	42.79	5.51	48.3	-56.9	105.2	160	150	Peak
5	5925	41.91	5.7	47.61	-20.59	68.2	160	150	Peak
6	* 5945.205	42.94	5.77	48.71	-19.49	68.2	160	150	Peak

Note : The EUT Power by Notebook PC

1. " * " means this data is the worst emission level.
2. C.F (Correction Factor) = Antenna Factor (dB)+ Cable Loss (dB) – Preamplifier(dB).
3. Measurement (dBUV/m) = Reading(dBUV) + C.F (Correction Factor).

EUT	WIFI USB DONGLE	Test Date	2017/12/25
Factor	BBHA 9120D (1GHz~18GHz)	Temp. / Humidity	21°C / 57%
Polarity	Vertical	Site / Engineer	AC1 / Peter
Test Mode	MODE2-CH165	Test Voltage	AC 120V/60Hz

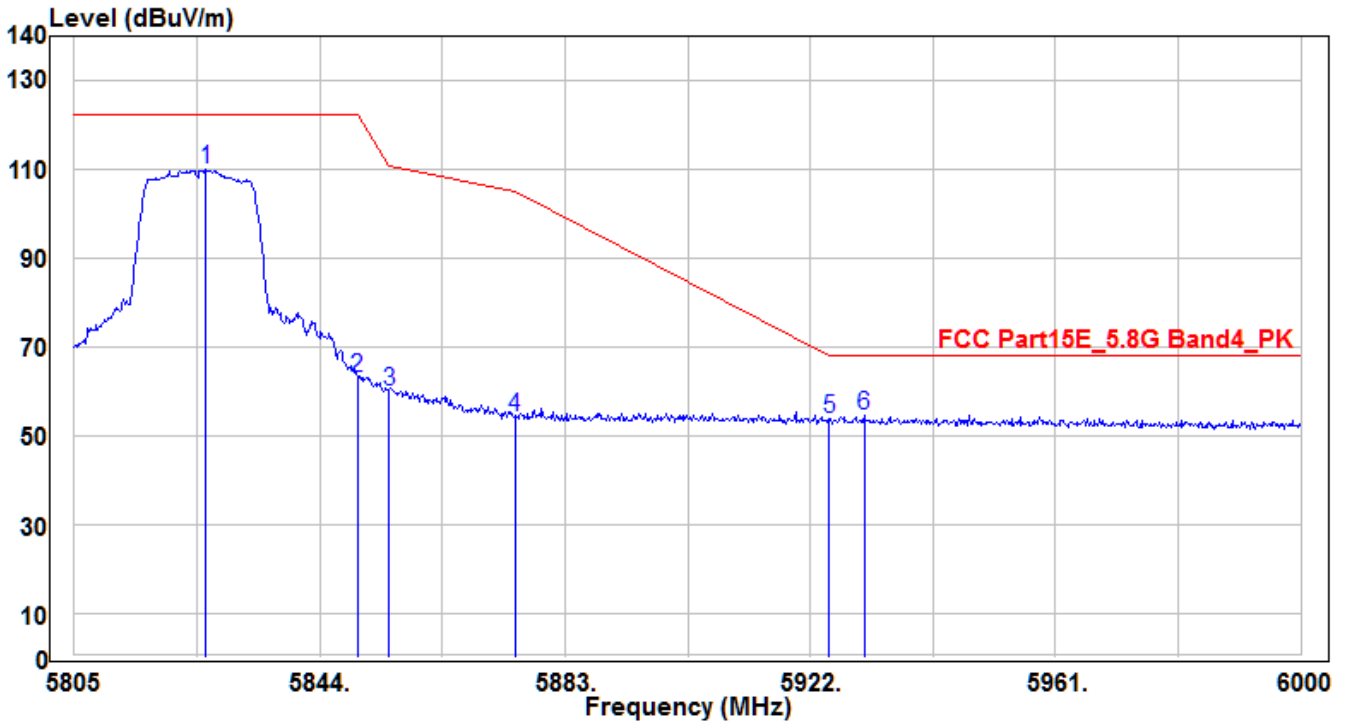

No	Frequency (MHz)	Reading (dBUV)	C.F (dB)	Measurement (dBUV/m)	Margin (dB)	Limit (dBUV/m)	Height (cm)	Angle (deg)	Remark (QP/PK/AV)
1	* 5825.865	104.54	5.32	109.86	-12.34	122.2	170	345	Peak
2	5850	57.87	5.41	63.28	-58.92	122.2	170	345	Peak
3	5855	54.68	5.44	60.12	-50.68	110.8	170	345	Peak
4	5875	48.92	5.51	54.43	-50.77	105.2	170	345	Peak
5	5925	48.27	5.7	53.97	-14.23	68.2	170	345	Peak
6	5930.58	48.98	5.72	54.7	-13.5	68.2	170	345	Peak

Note : The EUT Power by Notebook PC

1. " * " means this data is the worst emission level.
2. C.F (Correction Factor) = Antenna Factor (dB)+ Cable Loss (dB) – Preamplifier(dB).
3. Measurement (dBUV/m) = Reading(dBUV) + C.F (Correction Factor).

EUT	WIFI USB DONGLE	Test Date	2017/12/25
Factor	BBHA 9120D (1GHz~18GHz)	Temp. / Humidity	21°C / 57%
Polarity	Horizontal	Site / Engineer	AC1 / Peter
Test Mode	MODE3-CH38	Test Voltage	AC 120V/60Hz

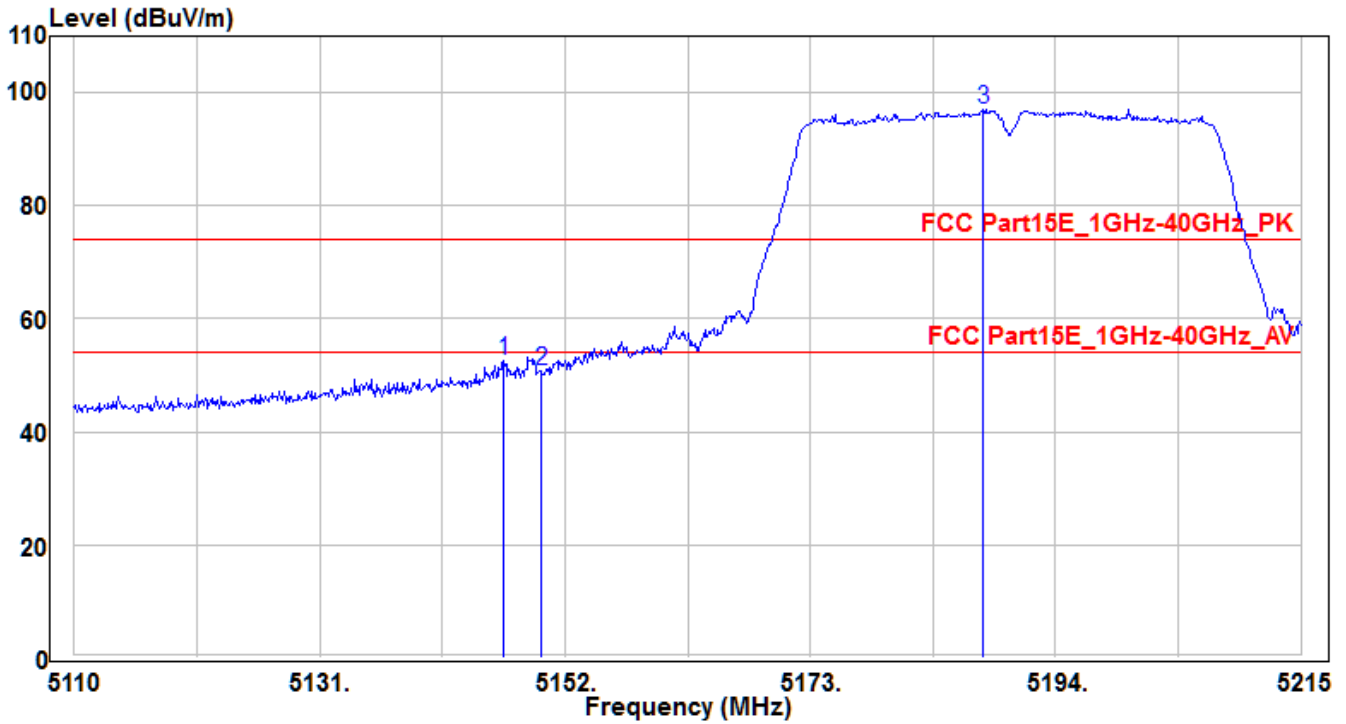

No	Frequency (MHz)	Reading (dBuV)	C.F (dB)	Measurement (dBuV/m)	Margin (dB)	Limit (dBuV/m)	Height (cm)	Angle (deg)	Remark (QP/PK/AV)	
1	*	5146.75	49.17	3.34	52.51	-21.49	74	155	325	Peak
2		5150.005	47.41	3.36	50.77	-23.23	74	155	325	Peak
3		5187.805	93.63	3.43	97.06	23.06	74	155	325	Peak

Note : The EUT Power by Notebook PC

1. " * " means this data is the worst emission level.
2. C.F (Correction Factor) = Antenna Factor (dB)+ Cable Loss (dB) – Preamplifier(dB).
3. Measurement (dBuV/m) = Reading(dBuV) + C.F (Correction Factor).

EUT	WIFI USB DONGLE	Test Date	2017/12/25
Factor	BBHA 9120D (1GHz~18GHz)	Temp. / Humidity	21°C / 57%
Polarity	Vertical	Site / Engineer	AC1 / Peter
Test Mode	MODE3-CH38	Test Voltage	AC 120V/60Hz

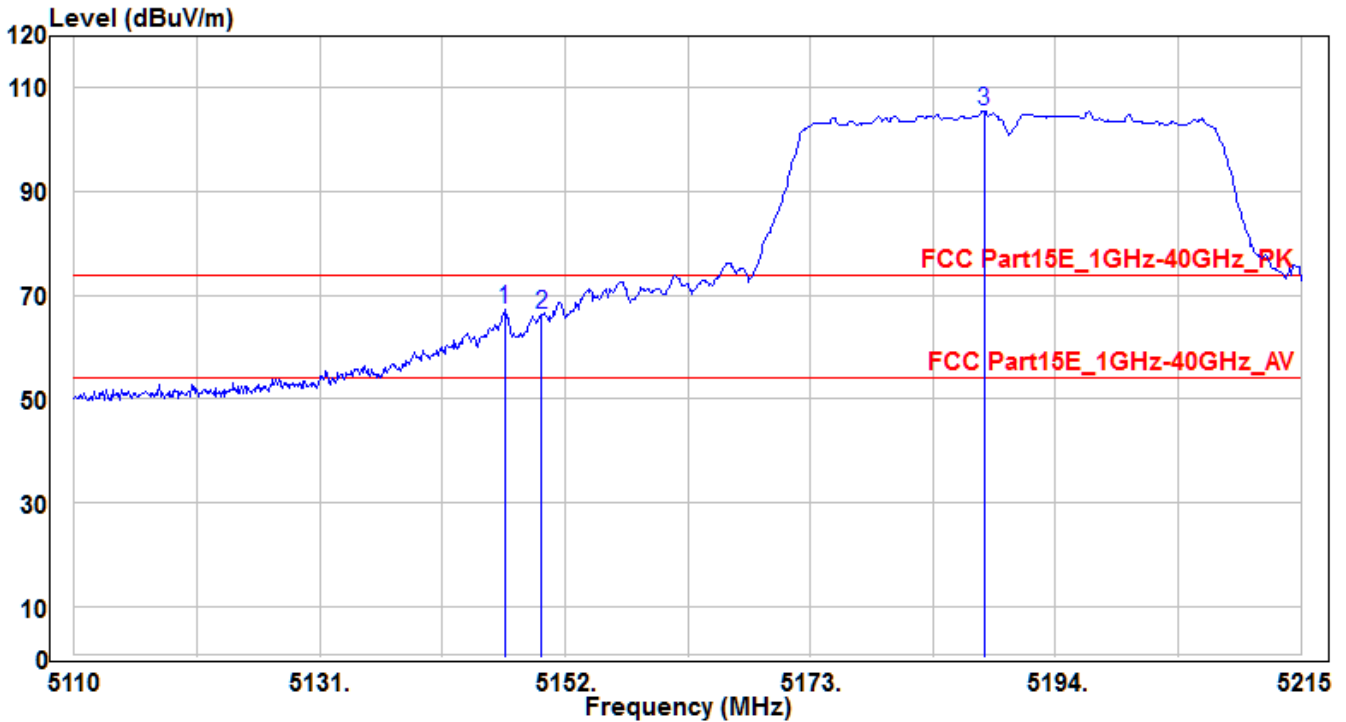

No	Frequency (MHz)	Reading (dBuV)	C.F (dB)	Measurement (dBuV/m)	Margin (dB)	Limit (dBuV/m)	Height (cm)	Angle (deg)	Remark (QP/PK/AV)	
1	*	5146.855	63.77	3.34	67.11	-6.89	74	170	280	Peak
2		5150	62.93	3.36	66.29	-7.71	74	170	280	Peak
3		5187.91	102.2	3.43	105.63	31.63	74	170	280	Peak

Note : The EUT Power by Notebook PC

- "*" means this data is the worst emission level.
- C.F (Correction Factor) = Antenna Factor (dB)+ Cable Loss (dB) – Preamplifier(dB).
- Measurement (dBuV/m) = Reading(dBuV) + C.F (Correction Factor).

EUT	WIFI USB DONGLE	Test Date	2017/12/25
Factor	BBHA 9120D (1GHz~18GHz)	Temp. / Humidity	21°C / 57%
Polarity	Vertical	Site / Engineer	AC1 / Peter
Test Mode	MODE3-CH38	Test Voltage	AC 120V/60Hz

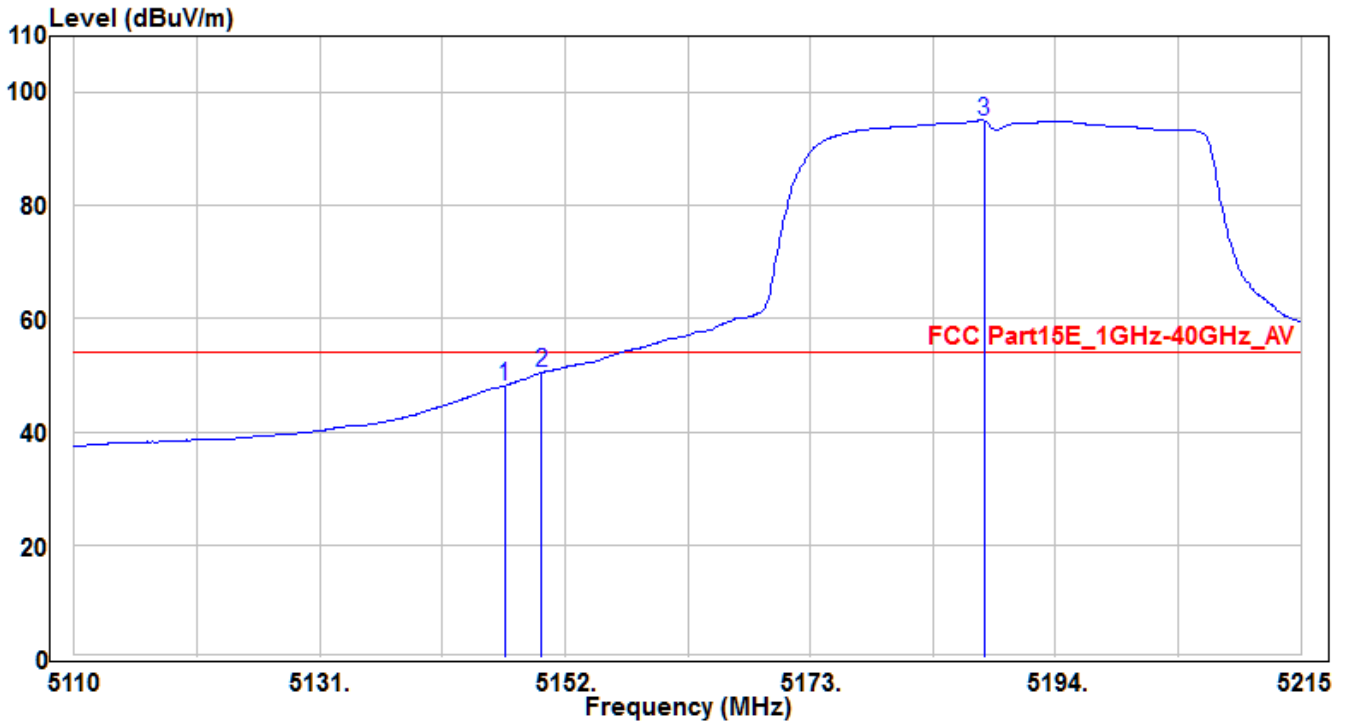

No	Frequency (MHz)	Reading (dBuV)	C.F (dB)	Measurement (dBuV/m)	Margin (dB)	Limit (dBuV/m)	Height (cm)	Angle (deg)	Remark (QP/PK/AV)
1	5146.855	44.83	3.34	48.17	-5.83	54	170	280	Average
2	* 5150	47.13	3.36	50.49	-3.51	54	170	280	Average
3	5187.91	91.61	3.43	95.04	41.04	54	170	280	Average

Note : The EUT Power by Notebook PC

1. " * " means this data is the worst emission level.
2. C.F (Correction Factor) = Antenna Factor (dB)+ Cable Loss (dB) – Preamplifier(dB).
3. Measurement (dBuV/m) = Reading(dBuV) + C.F (Correction Factor).

EUT	WIFI USB DONGLE	Test Date	2017/12/25
Factor	BBHA 9120D (1GHz~18GHz)	Temp. / Humidity	21°C / 57%
Polarity	Horizontal	Site / Engineer	AC1 / Peter
Test Mode	MODE3-CH151	Test Voltage	AC 120V/60Hz

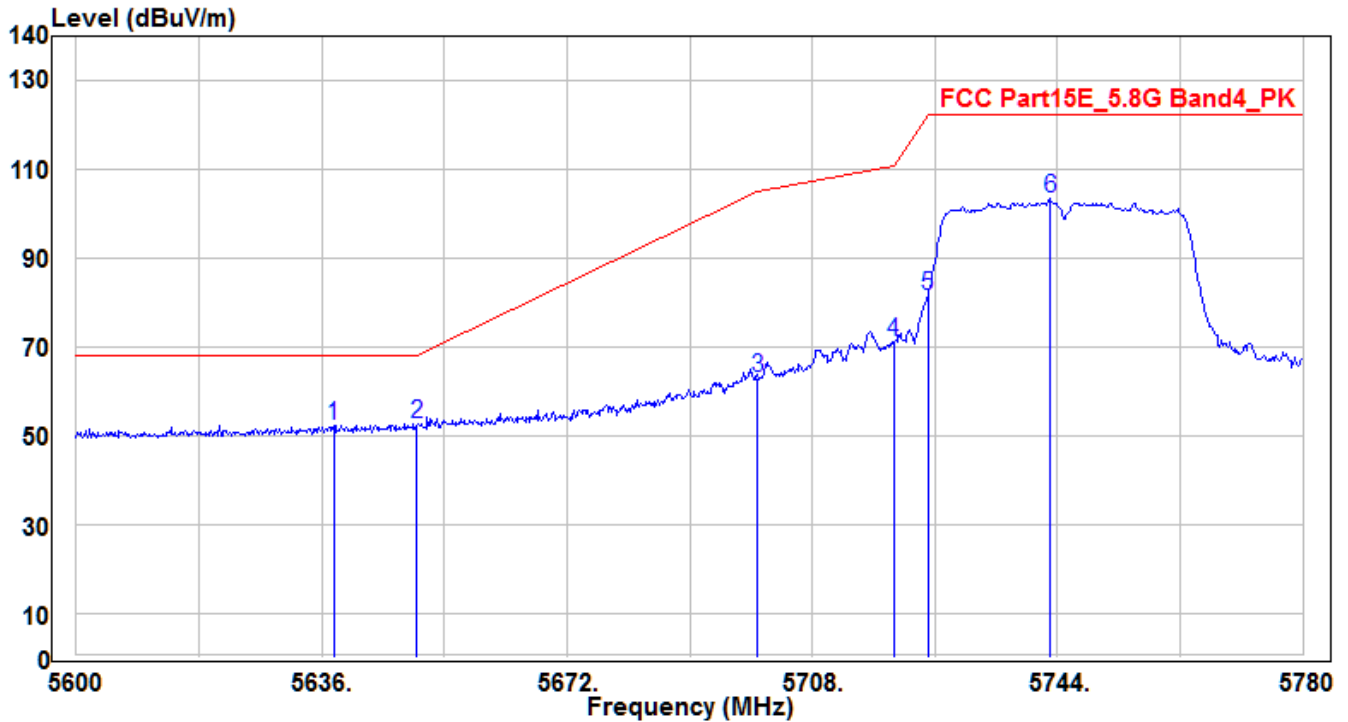

No	Frequency (MHz)	Reading (dBuV)	C.F (dB)	Measurement (dBuV/m)	Margin (dB)	Limit (dBuV/m)	Height (cm)	Angle (deg)	Remark (QP/PK/AV)
1	5637.8	47.88	4.6	52.48	-15.72	68.2	165	215	Peak
2	* 5650	47.91	4.65	52.56	-15.64	68.2	165	215	Peak
3	5700	58.2	4.84	63.04	-42.16	105.2	165	215	Peak
4	5720	66.29	4.91	71.2	-39.6	110.8	165	215	Peak
5	5725	76.61	4.93	81.54	-40.66	122.2	165	215	Peak
6	5742.92	98.39	5	103.39	-18.81	122.2	165	215	Peak

Note : The EUT Power by Notebook PC

1. " * " means this data is the worst emission level.
2. C.F (Correction Factor) = Antenna Factor (dB)+ Cable Loss (dB) – Preamplifier(dB).
3. Measurement (dBuV/m) = Reading(dBuV) + C.F (Correction Factor).

EUT	WIFI USB DONGLE	Test Date	2017/12/25
Factor	BBHA 9120D (1GHz~18GHz)	Temp. / Humidity	21°C / 57%
Polarity	Vertical	Site / Engineer	AC1 / Peter
Test Mode	MODE3-CH151	Test Voltage	AC 120V/60Hz

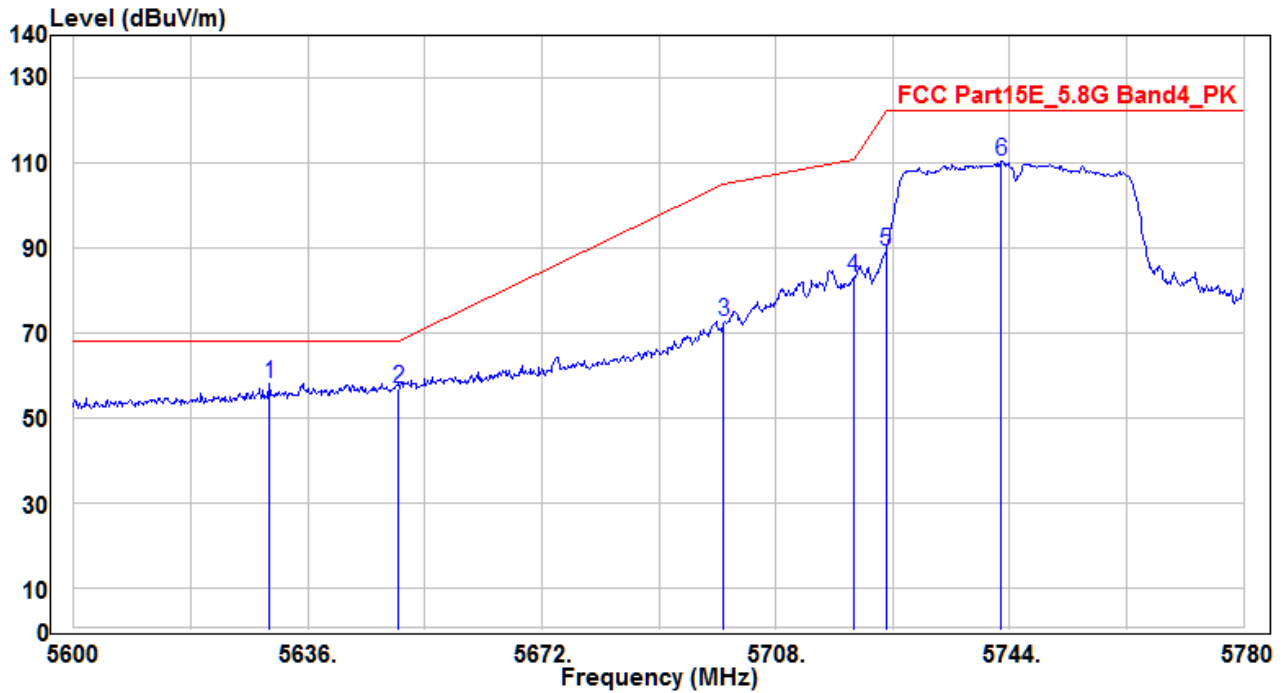

No	Frequency (MHz)	Reading (dBuV)	C.F (dB)	Measurement (dBuV/m)	Margin (dB)	Limit (dBuV/m)	Height (cm)	Angle (deg)	Remark (QP/PK/AV)
1	* 5630.06	53.46	4.57	58.03	-10.17	68.2	160	300	Peak
2	5650	52.39	4.65	57.04	-11.16	68.2	160	300	Peak
3	5700	67.71	4.84	72.55	-32.65	105.2	160	300	Peak
4	5720	78.24	4.91	83.15	-27.65	110.8	160	300	Peak
5	5725	84.45	4.93	89.38	-32.82	122.2	160	300	Peak
6	5742.74	105.53	5	110.53	-11.67	122.2	160	300	Peak

Note : The EUT Power by Notebook PC

1. " * " means this data is the worst emission level.
2. C.F (Correction Factor) = Antenna Factor (dB)+ Cable Loss (dB) – Preamplifier(dB).
3. Measurement (dBuV/m) = Reading(dBuV) + C.F (Correction Factor).

EUT	WIFI USB DONGLE	Test Date	2017/12/25
Factor	BBHA 9120D (1GHz~18GHz)	Temp. / Humidity	21°C / 57%
Polarity	Horizontal	Site / Engineer	AC1 / Peter
Test Mode	MODE3-CH159	Test Voltage	AC 120V/60Hz

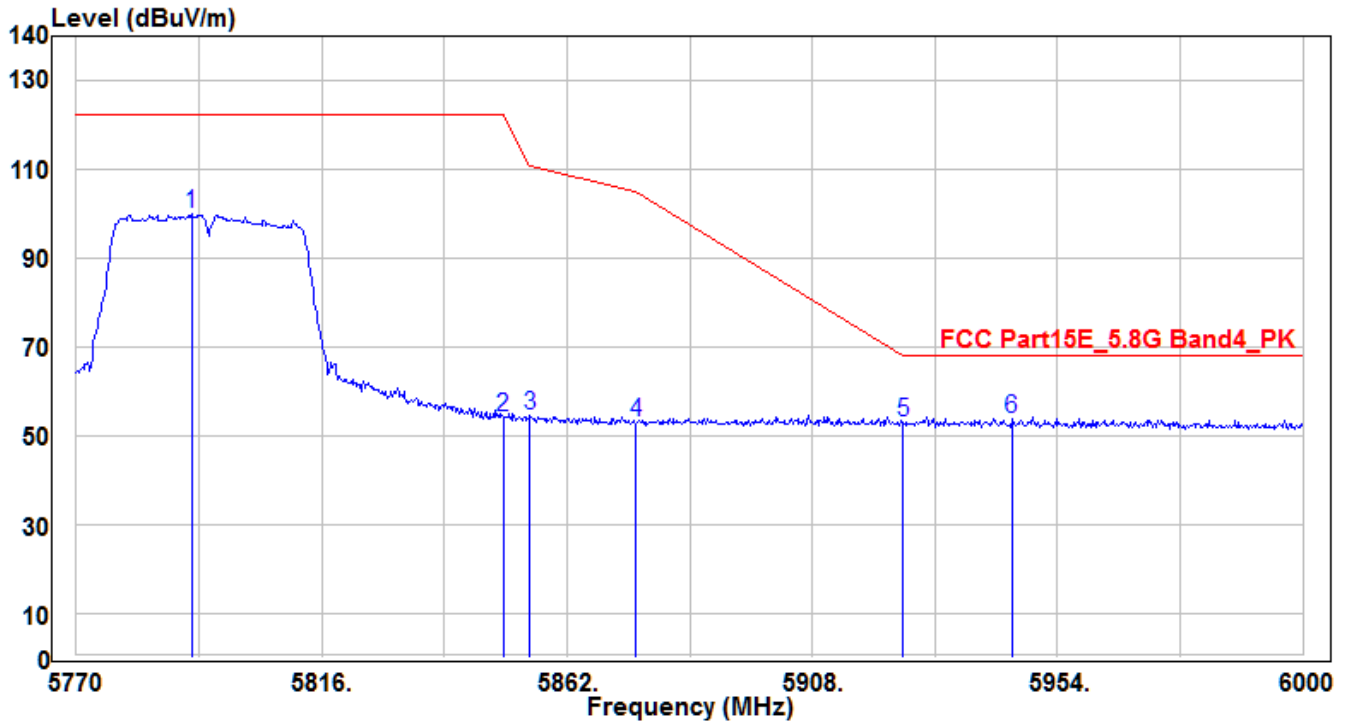

No	Frequency (MHz)	Reading (dBuV)	C.F (dB)	Measurement (dBuV/m)	Margin (dB)	Limit (dBuV/m)	Height (cm)	Angle (deg)	Remark (QP/PK/AV)
1	5791.62	94.66	5.19	99.85	-22.35	122.2	185	150	Peak
2	5850	48.99	5.41	54.4	-67.8	122.2	185	150	Peak
3	5855	49.01	5.44	54.45	-56.35	110.8	185	150	Peak
4	5875	47.73	5.51	53.24	-51.96	105.2	185	150	Peak
5	5925	47.23	5.7	52.93	-15.27	68.2	185	150	Peak
6	* 5945.49	48.02	5.77	53.79	-14.41	68.2	185	150	Peak

Note : The EUT Power by Notebook PC

1. " * " means this data is the worst emission level.
2. C.F (Correction Factor) = Antenna Factor (dB)+ Cable Loss (dB) – Preamplifier(dB).
3. Measurement (dBuV/m) = Reading(dBuV) + C.F (Correction Factor).

EUT	WIFI USB DONGLE	Test Date	2017/12/25
Factor	BBHA 9120D (1GHz~18GHz)	Temp. / Humidity	21°C / 57%
Polarity	Vertical	Site / Engineer	AC1 / Peter
Test Mode	MODE3-CH159	Test Voltage	AC 120V/60Hz

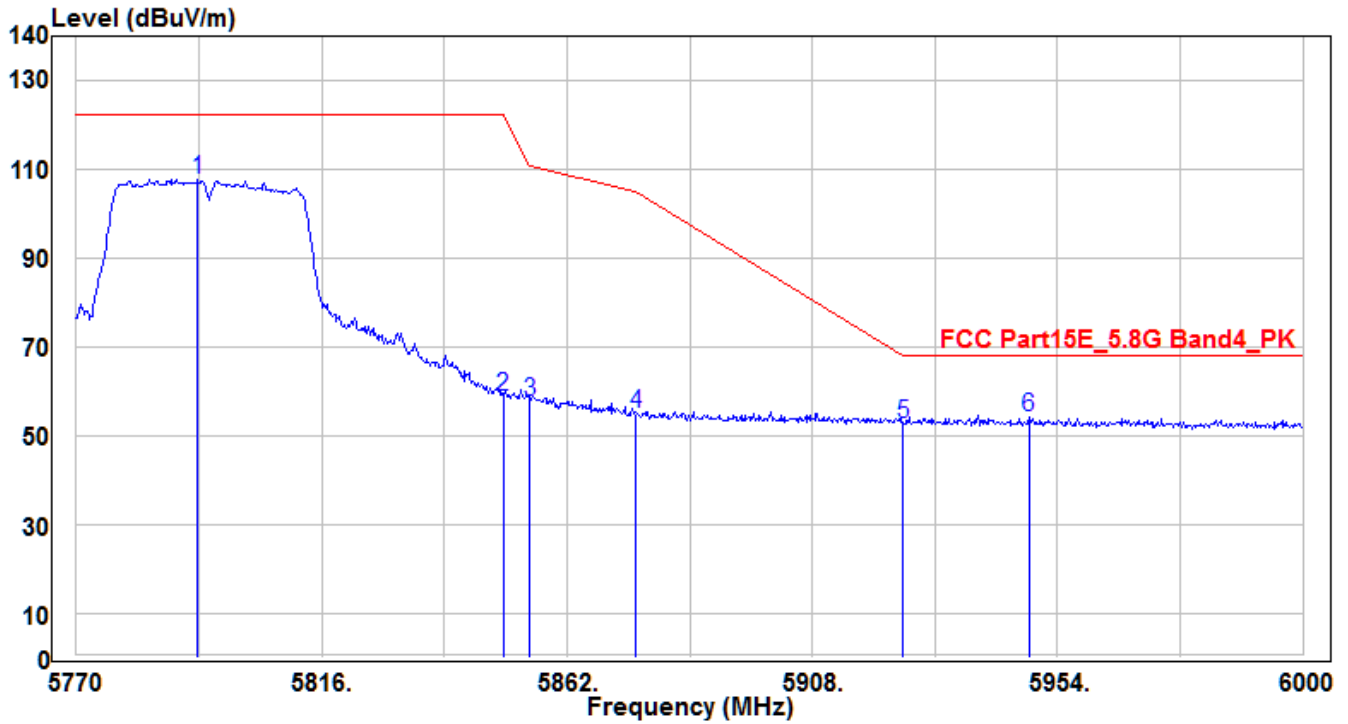

No	Frequency (MHz)	Reading (dBuV)	C.F (dB)	Measurement (dBuV/m)	Margin (dB)	Limit (dBuV/m)	Height (cm)	Angle (deg)	Remark (QP/PK/AV)
1	5792.77	102.69	5.2	107.89	-14.31	122.2	165	320	Peak
2	5850	53.56	5.41	58.97	-63.23	122.2	165	320	Peak
3	5855	52.41	5.44	57.85	-52.95	110.8	165	320	Peak
4	5875	49.63	5.51	55.14	-50.06	105.2	165	320	Peak
5	5925	47.15	5.7	52.85	-15.35	68.2	165	320	Peak
6	* 5948.71	48.27	5.8	54.07	-14.13	68.2	165	320	Peak

Note : The EUT Power by Notebook PC

1. " * " means this data is the worst emission level.
2. C.F (Correction Factor) = Antenna Factor (dB)+ Cable Loss (dB) – Preamplifier(dB).
3. Measurement (dBuV/m) = Reading(dBuV) + C.F (Correction Factor).

EUT	WIFI USB DONGLE	Test Date	2017/12/25
Factor	BBHA 9120D (1GHz~18GHz)	Temp. / Humidity	21°C / 57%
Polarity	Horizontal	Site / Engineer	AC1 / Peter
Test Mode	MODE4-CH42	Test Voltage	AC 120V/60Hz

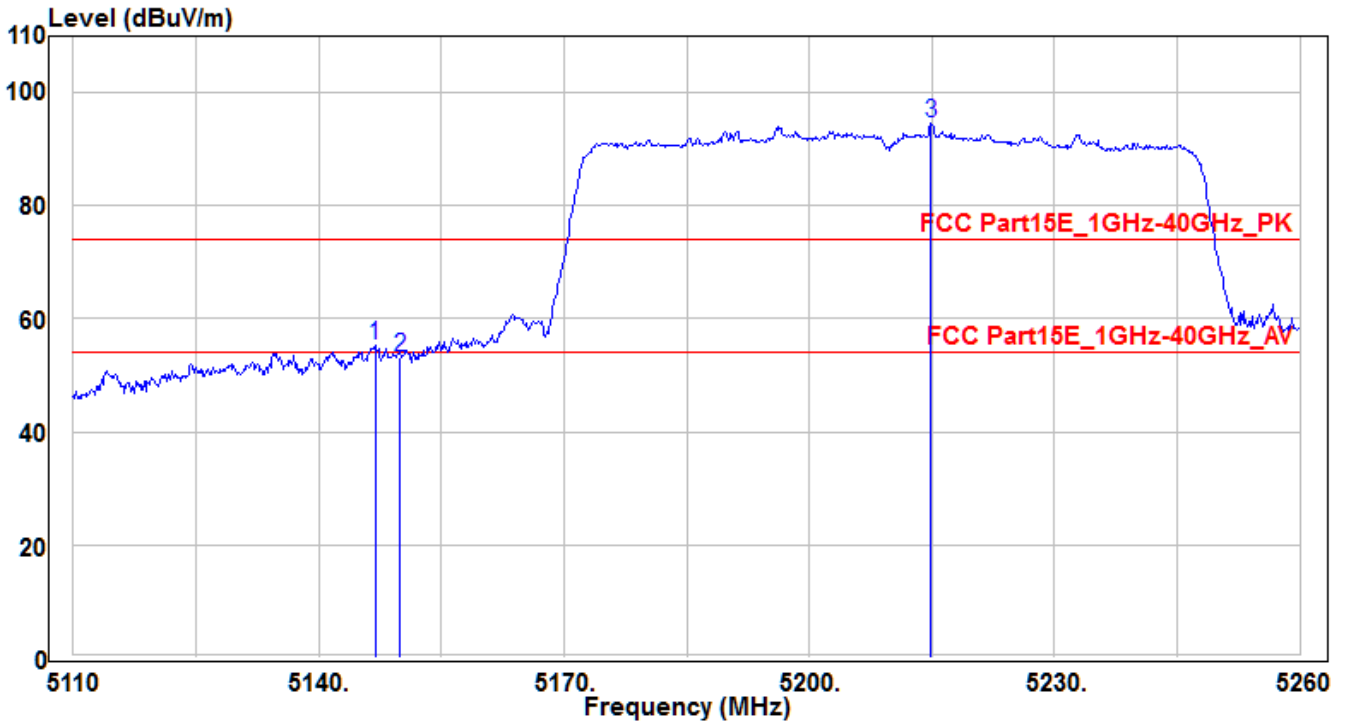

No	Frequency (MHz)	Reading (dBuV)	C.F (dB)	Measurement (dBuV/m)	Margin (dB)	Limit (dBuV/m)	Height (cm)	Angle (deg)	Remark (QP/PK/AV)
1	*	51.91	3.35	55.26	-18.74	74	150	170	Peak
2		49.78	3.36	53.14	-20.86	74	150	170	Peak
3		91.06	3.48	94.54	20.54	74	150	170	Peak

Note : The EUT Power by Notebook PC

- "*" means this data is the worst emission level.
- C.F (Correction Factor) = Antenna Factor (dB)+ Cable Loss (dB) – Preamplifier(dB).
- Measurement (dBuV/m) = Reading(dBuV) + C.F (Correction Factor).

EUT	WIFI USB DONGLE	Test Date	2017/12/25
Factor	BBHA 9120D (1GHz~18GHz)	Temp. / Humidity	21°C / 57%
Polarity	Horizontal	Site / Engineer	AC1 / Peter
Test Mode	MODE4-CH42	Test Voltage	AC 120V/60Hz

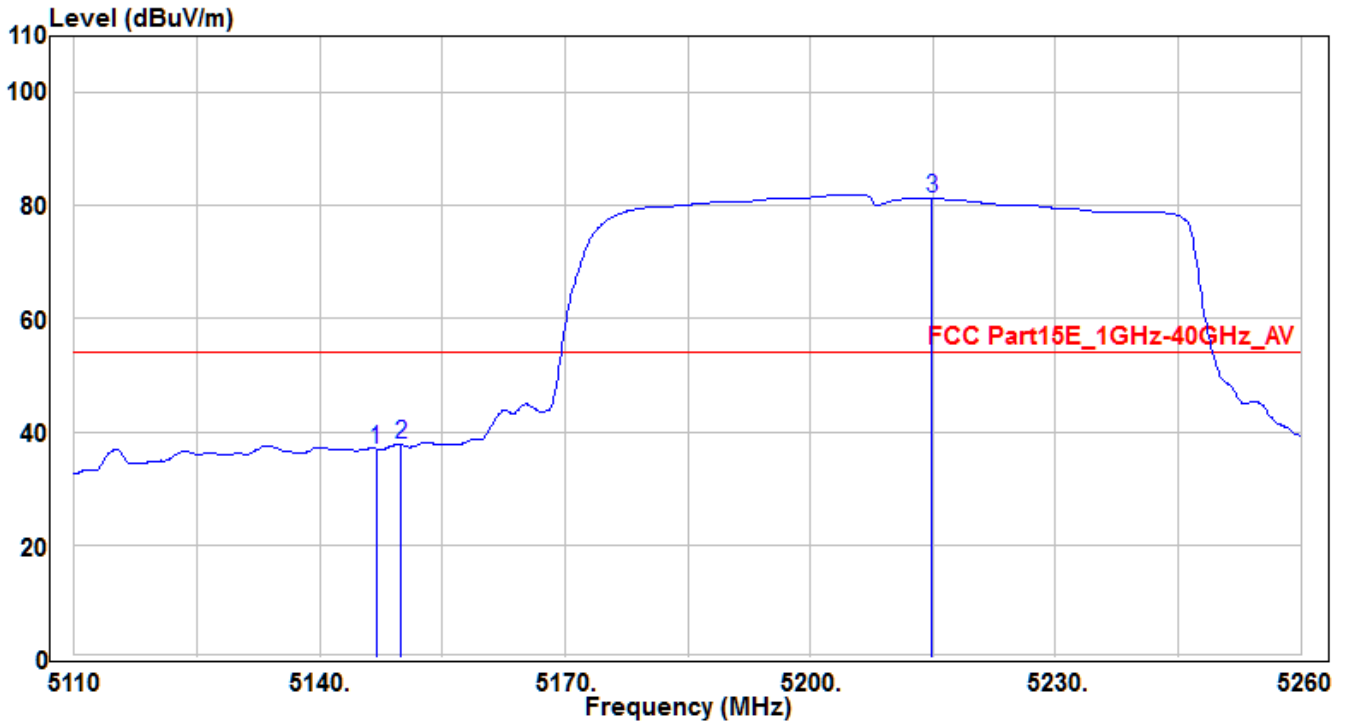

No	Frequency (MHz)	Reading (dBuV)	C.F (dB)	Measurement (dBuV/m)	Margin (dB)	Limit (dBuV/m)	Height (cm)	Angle (deg)	Remark (QP/PK/AV)
1	5146.9	33.66	3.35	37.01	-16.99	54	150	170	Average
2	* 5150	34.39	3.36	37.75	-16.25	54	150	170	Average
3	5214.85	77.9	3.48	81.38	27.38	54	150	170	Average

Note : The EUT Power by Notebook PC

- "*" means this data is the worst emission level.
- C.F (Correction Factor) = Antenna Factor (dB)+ Cable Loss (dB) – Preamplifier(dB).
- Measurement (dBuV/m) = Reading(dBuV) + C.F (Correction Factor).

EUT	WIFI USB DONGLE	Test Date	2017/12/25
Factor	BBHA 9120D (1GHz~18GHz)	Temp. / Humidity	21°C / 57%
Polarity	Vertical	Site / Engineer	AC1 / Peter
Test Mode	MODE4-CH42	Test Voltage	AC 120V/60Hz

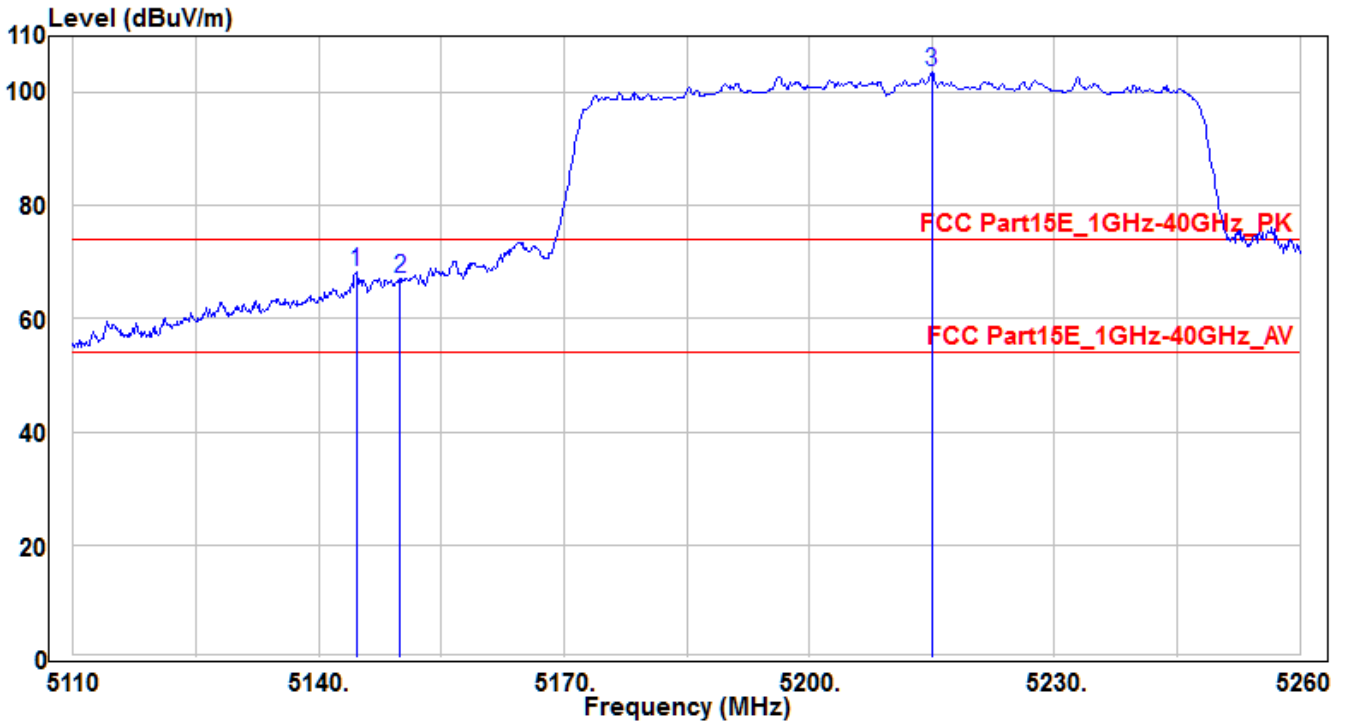

No	Frequency (MHz)	Reading (dBuV)	C.F (dB)	Measurement (dBuV/m)	Margin (dB)	Limit (dBuV/m)	Height (cm)	Angle (deg)	Remark (QP/PK/AV)
1	* 5144.65	64.87	3.34	68.21	-5.79	74	190	240	Peak
2	5150	63.75	3.36	67.11	-6.89	74	190	240	Peak
3	5215	100.07	3.48	103.55	29.55	74	190	240	Peak

Note : The EUT Power by Notebook PC

- "*" means this data is the worst emission level.
- C.F (Correction Factor) = Antenna Factor (dB)+ Cable Loss (dB) – Preamplifier(dB).
- Measurement (dBuV/m) = Reading(dBuV) + C.F (Correction Factor).

EUT	WIFI USB DONGLE	Test Date	2017/12/25
Factor	BBHA 9120D (1GHz~18GHz)	Temp. / Humidity	21°C / 57%
Polarity	Vertical	Site / Engineer	AC1 / Peter
Test Mode	MODE4-CH42	Test Voltage	AC 120V/60Hz

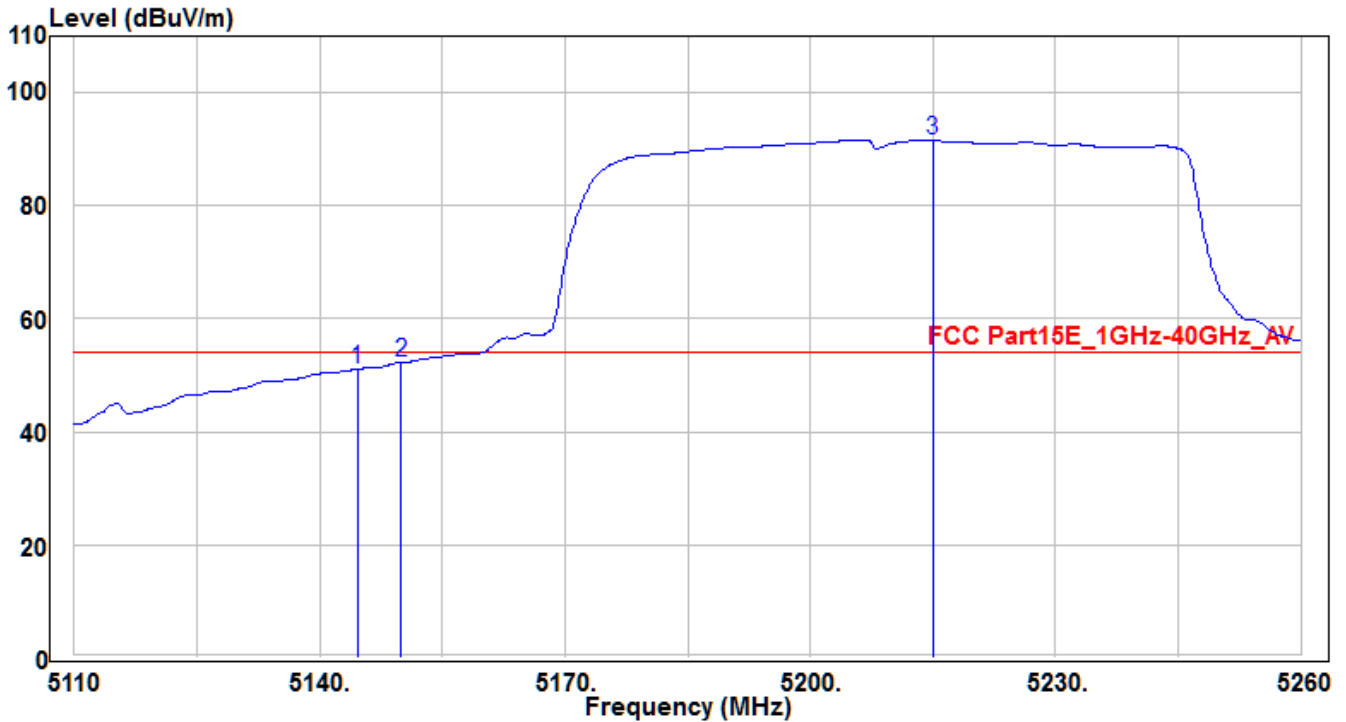

No	Frequency (MHz)	Reading (dBuV)	C.F (dB)	Measurement (dBuV/m)	Margin (dB)	Limit (dBuV/m)	Height (cm)	Angle (deg)	Remark (QP/PK/AV)
1	5144.65	47.63	3.34	50.97	-3.03	54	190	240	Average
2	* 5150	49.02	3.36	52.38	-1.62	54	190	240	Average
3	5215	88.1	3.48	91.58	37.58	54	190	240	Average

Note : The EUT Power by Notebook PC

1. " * " means this data is the worst emission level.
2. C.F (Correction Factor) = Antenna Factor (dB)+ Cable Loss (dB) – Preamplifier(dB).
3. Measurement (dBuV/m) = Reading(dBuV) + C.F (Correction Factor).

EUT	WIFI USB DONGLE	Test Date	2017/12/25
Factor	BBHA 9120D (1GHz~18GHz)	Temp. / Humidity	21°C / 57%
Polarity	Horizontal	Site / Engineer	AC1 / Peter
Test Mode	MODE4-CH155	Test Voltage	AC 120V/60Hz

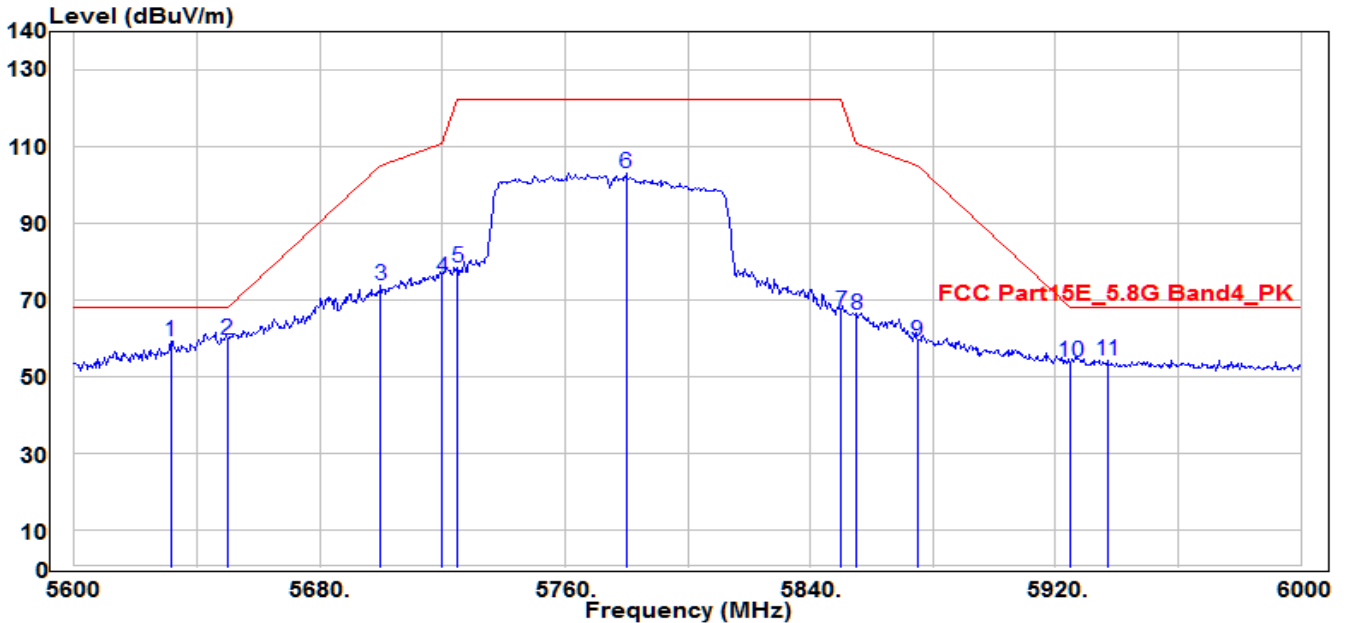

No	Frequency (MHz)	Reading (dBUV)	C.F (dB)	Measurement (dBUV/m)	Margin (dB)	Limit (dBUV/m)	Height (cm)	Angle (deg)	Remark (QP/PK/AV)
1	5631.6	54.78	4.57	59.35	-8.85	68.2	175	150	Peak
2	* 5650	55.03	4.65	59.68	-8.52	68.2	175	150	Peak
3	5700	68.95	4.84	73.79	-31.41	105.2	175	150	Peak
4	5720	70.86	4.91	75.77	-35.03	110.8	175	150	Peak
5	5725	73.36	4.93	78.29	-43.91	122.2	175	150	Peak
6	5780	97.93	5.15	103.08	-19.12	122.2	175	150	Peak
7	5850	61.46	5.41	66.87	-55.33	122.2	175	150	Peak
8	5855	60.62	5.44	66.06	-44.74	110.8	175	150	Peak
9	5875	53.74	5.51	59.25	-45.95	105.2	175	150	Peak
10	5925	48.03	5.7	53.73	-14.47	68.2	175	150	Peak
11	5936.8	48.49	5.75	54.24	-13.96	68.2	175	150	Peak

Note : The EUT Power by Notebook PC

1. " * " means this data is the worst emission level.
2. C.F (Correction Factor) = Antenna Factor (dB)+ Cable Loss (dB) – Preamplifier(dB).
3. Measurement (dBUV/m) = Reading(dBUV) + C.F (Correction Factor).

EUT	WIFI USB DONGLE	Test Date	2017/12/25
Factor	BBHA 9120D (1GHz~18GHz)	Temp. / Humidity	21°C / 57%
Polarity	Vertical	Site / Engineer	AC1 / Peter
Test Mode	MODE4-CH155	Test Voltage	AC 120V/60Hz

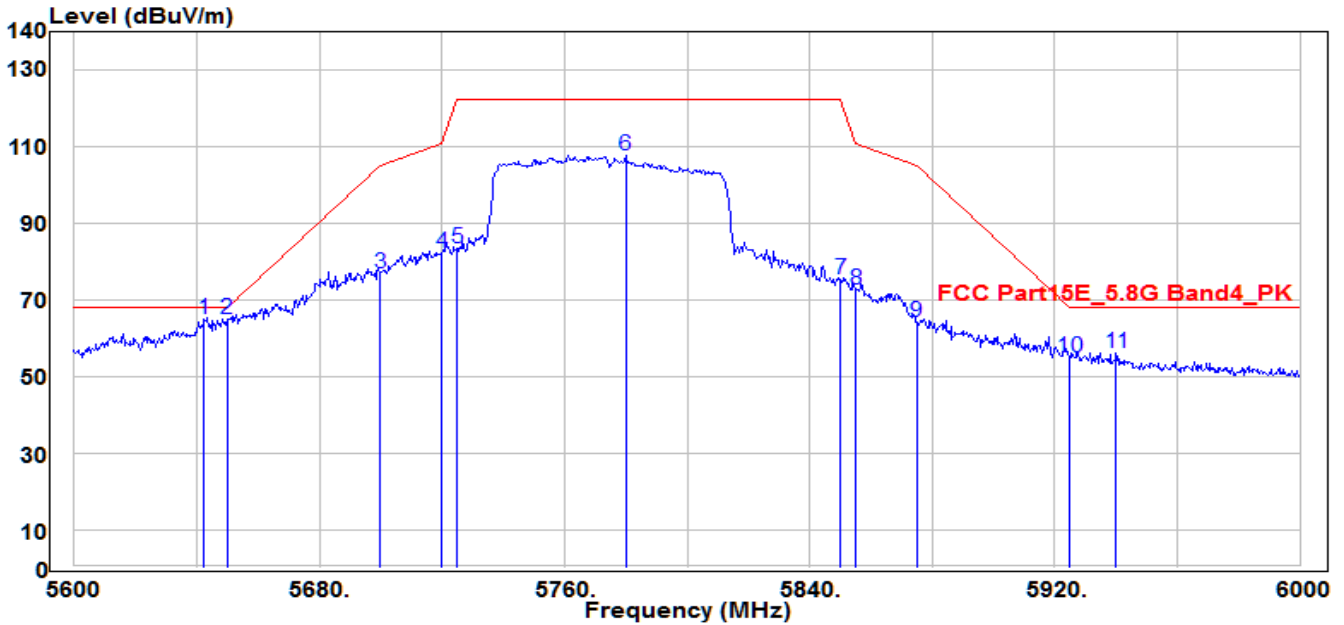

No	Frequency (MHz)	Reading (dBuV)	C.F (dB)	Measurement (dBuV/m)	Margin (dB)	Limit (dBuV/m)	Height (cm)	Angle (deg)	Remark (QP/PK/AV)
1	5642.4	60.23	4.62	64.85	-3.35	68.2	150	400	Peak
2	* 5650	60.39	4.65	65.04	-3.16	68.2	150	400	Peak
3	5700	72.12	4.84	76.96	-28.24	105.2	150	400	Peak
4	5720	77.28	4.91	82.19	-28.61	110.8	150	400	Peak
5	5725	78.49	4.93	83.42	-38.78	122.2	150	400	Peak
6	5780	102.52	5.15	107.67	-14.53	122.2	150	400	Peak
7	5850	69.94	5.41	75.35	-46.85	122.2	150	400	Peak
8	5855	67.37	5.44	72.81	-37.99	110.8	150	400	Peak
9	5875	58.64	5.51	64.15	-41.05	105.2	150	400	Peak
10	5925	49.27	5.7	54.97	-13.23	68.2	150	400	Peak
11	5940	50.25	5.76	56.01	-12.19	68.2	150	400	Peak

Note : The EUT Power by Notebook PC

- "*" means this data is the worst emission level.
- C.F (Correction Factor) = Antenna Factor (dB)+ Cable Loss (dB) – Preamplifier(dB).
- Measurement (dBuV/m) = Reading(dBuV) + C.F (Correction Factor) .

7.9. AC Conducted Emissions Measurement

7.9.1. Test Limit

FCC Part 15.207 Limits		
Frequency (MHz)	QP (dB μ V)	AV (dB μ V)
0.15 ~ 0.50	66 ~ 56	56 ~ 46
0.50 ~ 5.0	56	46
5.0 ~ 30	60	50

Note 1: The lower limit shall apply at the transition frequencies.

Note 2: The limit decreases linearly with the logarithm of the frequency in the range 0.15MHz to 0.5MHz.

7.9.2. Test Procedure

The EUT was setup according to ANSI C63.4, 2009 and tested according to KDB 789033 for compliance to FCC 47CFR 15.247 requirements. The EUT was placed on a platform of nominal size, 1 m by 1.5 m, raised 80 cm above the conducting ground plane. The vertical conducting plane was located 40 cm to the rear of the EUT. All other surfaces of EUT were at least 80 cm from any other grounded conducting surface. The EUT and simulators are connected to the main power through a line impedance stabilization network (LISN). The LISN provides a 50 ohm /50uH coupling impedance for the measuring equipment. The peripheral devices are also connected to the main power through a LISN. (Please refer to the block diagram of the test setup and photographs) Each current-carrying conductor of the EUT power cord, except the ground (safety) conductor, was individually connected through a LISN to the input power source.

The excess length of the power cord between the EUT and the LISN receptacle were folded back and forth at the center of the lead to form a bundle not exceeding 40 cm in length.

Conducted emissions were investigated over the frequency range from 0.15MHz to 30MHz using a receiver bandwidth of 9 kHz.

7.9.3. Test Setup

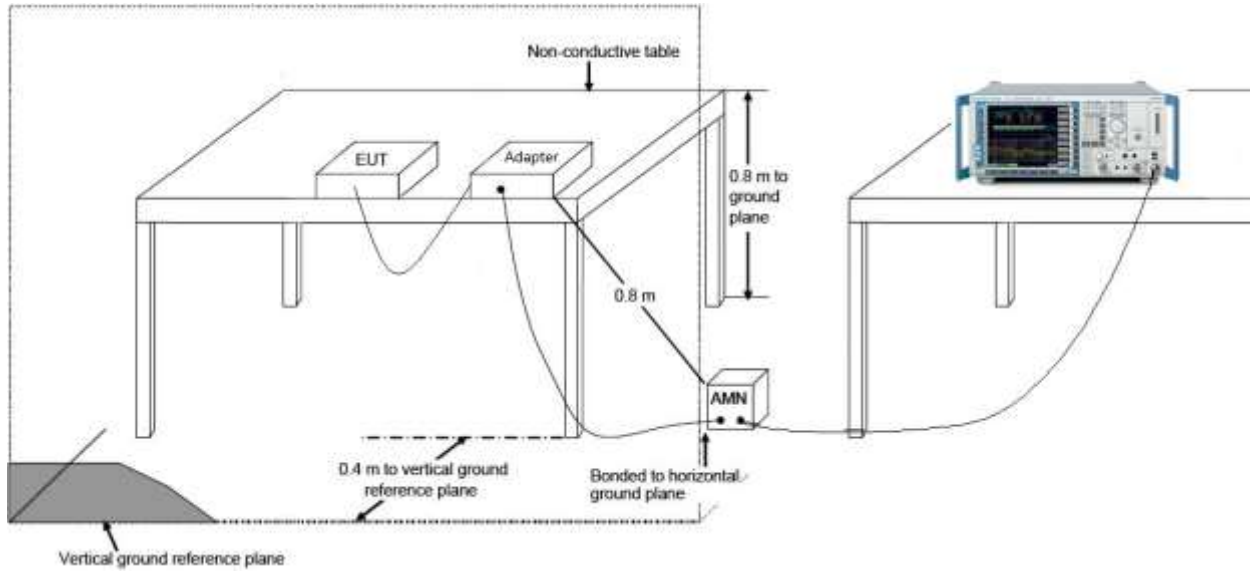

7.9.4. Test Result

EUT	WIFI USB DONGLE	Test Date	2017/03/24
Factor	CE_ENV216-L1 (Filter ON)	Temp. / Humidity	24°C / 55%
Polarity	Line1	Site / Engineer	SR2 / Peter
Test Mode	MODE3	Test Voltage	AC120V/60Hz

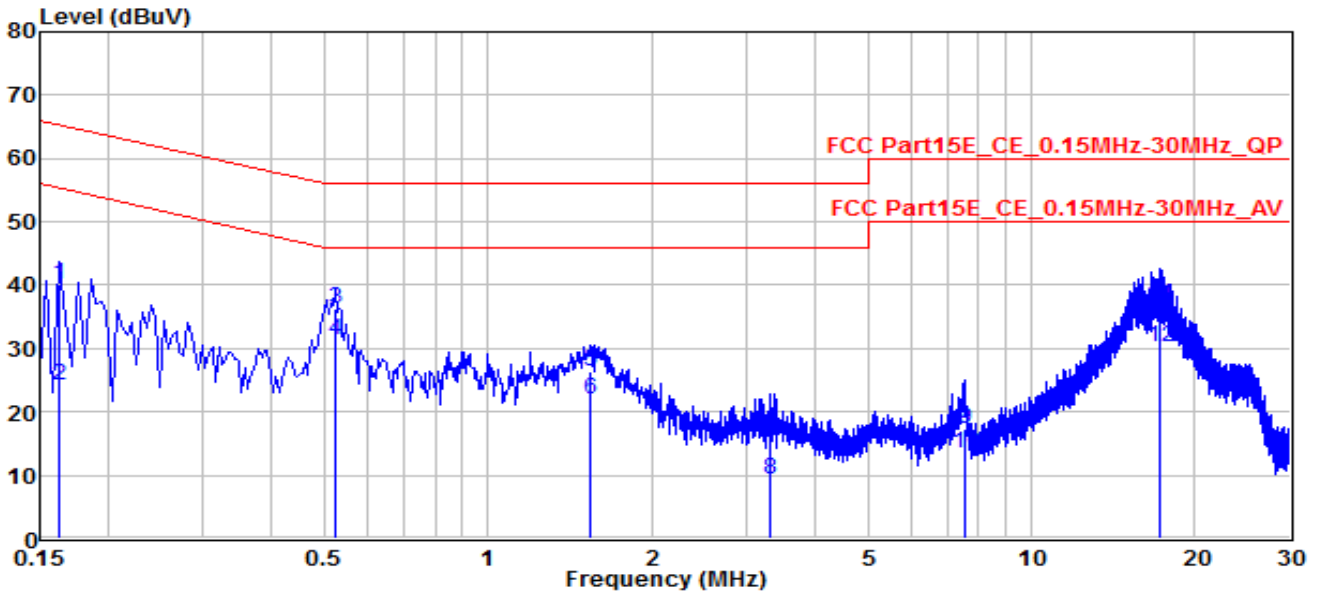

No	Frequency (MHz)	Reading (dBuV)	C.F (dB)	Measurement (dBuV)	Margin (dB)	Limit (dBuV)	Remark (QP/PK/AV)
1	0.1635	30.18	10.08	40.26	-25.02	65.28	QP
2	0.1635	14.14	10.08	24.22	-31.06	55.28	Average
3	* 0.52346	26.33	10.08	36.41	-19.59	56	QP
4	* 0.52346	21.28	10.08	31.36	-14.64	46	Average
5	1.545	16.63	9.87	26.5	-29.5	56	QP
6	1.545	11.99	9.87	21.86	-24.14	46	Average
7	3.3	5.72	9.81	15.53	-40.47	56	QP
8	3.3	-0.36	9.81	9.45	-36.55	46	Average
9	7.529	7.56	9.79	17.35	-42.65	60	QP
10	7.529	3.6	9.79	13.39	-36.61	50	Average
11	17.271	26.9	9.98	36.88	-23.12	60	QP
12	17.271	20.36	9.98	30.34	-19.66	50	Average

Note : The EUT Power by Notebook PC

- "*" means this data is the worst emission level.
- C.F (Correction Factor) = Factor (dB)+ Cable Loss (dB).
- Measurement (dBuV) = Reading(dBuV)+ C.F (Correction Factor).

EUT	WIFI USB DONGLE	Test Date	2017/03/24
Factor	CE_ENV216-N (Filter ON)	Temp. / Humidity	24°C / 55%
Polarity	Neutral	Site / Engineer	SR2 / Peter
Test Mode	MODE3	Test Voltage	AC120V/60Hz

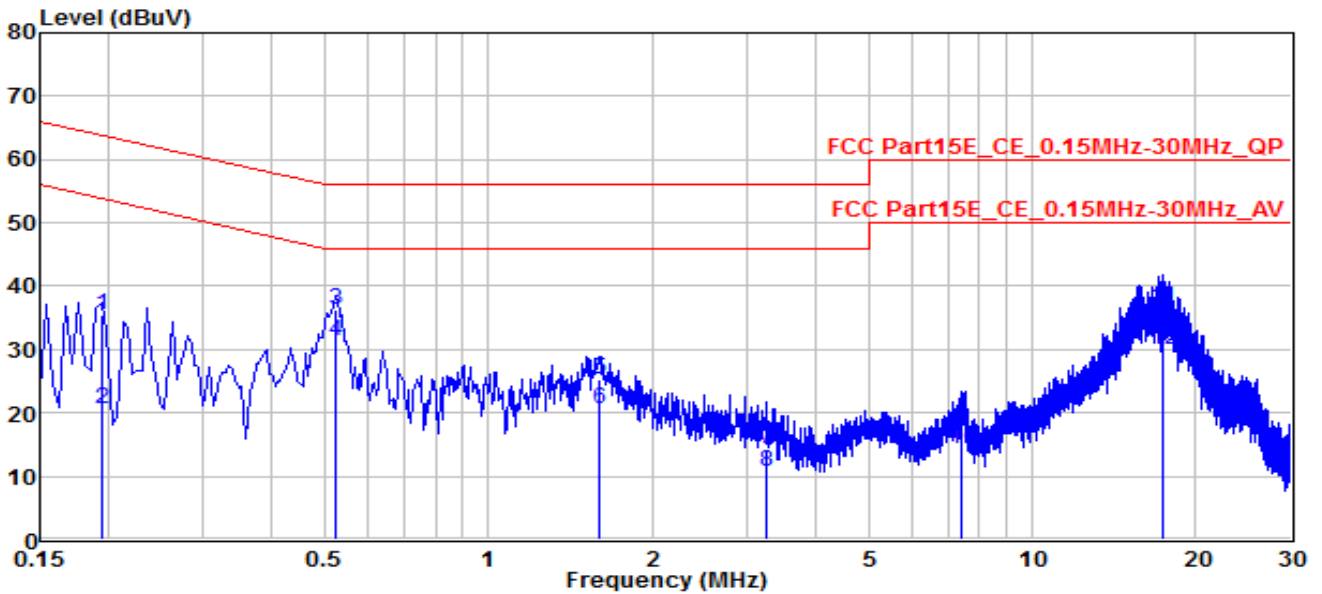

No	Frequency (MHz)	Reading (dBuV)	C.F (dB)	Measurement (dBuV)	Margin (dB)	Limit (dBuV)	Remark (QP/PK/AV)
1	0.195	25.53	9.98	35.51	-28.31	63.82	QP
2	0.195	10.7	9.98	20.68	-33.14	53.82	Average
3	* 0.52346	26.29	10.11	36.4	-19.6	56	QP
4	* 0.52346	21.14	10.11	31.25	-14.75	46	Average
5	1.608	15.55	9.87	25.42	-30.58	56	QP
6	1.608	10.75	9.87	20.62	-25.38	46	Average
7	3.259	4.58	9.82	14.4	-41.6	56	QP
8	3.259	0.77	9.82	10.59	-35.41	46	Average
9	7.448	7.85	9.81	17.66	-42.34	60	QP
10	7.448	4.59	9.81	14.4	-35.6	50	Average
11	17.388	26.62	10.03	36.65	-23.35	60	QP
12	17.388	19.92	10.03	29.95	-20.05	50	Average

Note : The EUT Power by Notebook PC

1. " * " means this data is the worst emission level.
2. C.F (Correction Factor) = Factor (dB)+ Cable Loss (dB).
3. Measurement (dBuV) = Reading(dBuV)+ C.F (Correction Factor).

8. CONCLUSION

The data collected relate only the item(s) tested and show that the **WIFI USB DONGLE , FCC ID: TKZAW2405AC1, Model Number: AW2405-AC1** is in compliance with Part 15E of the FCC Rules & IC Rules.

————— The End —————