

13.56MHz RFID Reader IC

TRH031M

(TRH031M-S: super plus version)

TRH031M (S version)

TRH031M is a 13.56MHz RFID Reader IC satisfying RFID international standards. It's divided into analog transceiver and digital part. Analog transceiver is driver for antenna, transmitter for data modulation and transmission, and receiver for card response demodulation. Digital part is Encoder/Decoder block, parity, CRC process logic, MCU interface, etc. Digital part mainly executes protocol process and execution.

TRH031M contains 8bit Timer and 128byte FIFO and they perform Packet communication. TRH031M is ideal for mobile application that requires battery power since it operates on 3.3V low voltage and very limited power consumption on Power down mode. Also system optimization becomes easy with simple antenna design and matching circuit configuration. (Product number: Old version – yywwdd/082402 , S version – yyww/0936)

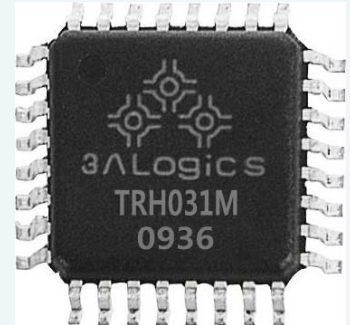

Application

- Digital Door-Lock / Entrance Management
- E-cash Reader
- Public Transport Terminals
- Handheld Terminals
- On Board Units
- Contactless PC Terminals

Features

- Basic information
 - 13.56MHz Multi-protocol RFID Reader chip
 - 3.3V operation voltage
 - 32pin LQFP package
- Supported Protocols:
 - ISO 14443 A/B Type, ISO 15693
 - Tag-it (Texas Instrument)
- Performs Analog and Digital mixed operation as standards indicated
 - Modulation/Demodulation, Encoding/Decoding
 - Framing and Collision Detection for Anti-collision
 - Automatic Data integrity check
- Functions for microprocessor interface
 - 128 bytes FIFO buffer for immediate data storage
 - 4 type of Parallel interface and SPI Serial interface
 - Configurable interrupt can inform event to microprocessor
 - Configurable and Adjustable timer function can cooperated with transceiver state and interrupt
- Power consumption minimization
 - Hardware/Software power down function
 - Minimized leakage and stand-by current
- Other functions
 - Receiver auto calibration function (Offset cancellation)
 - Transmit power and modulation index configuration
 - Two Transmit driver can be configured
 - Adjustable receiver sensitivity depends on noise condition
 - Data rate and pulse width configuration according to protocol standards
 - Test pins for operation check



Block diagram

TRH031M is divided into analog part that handles physical data receiving/transmitting and digital part that handles Encoding/decoding, framing, data integrity check and timer. Please see below block diagram for detailed information.

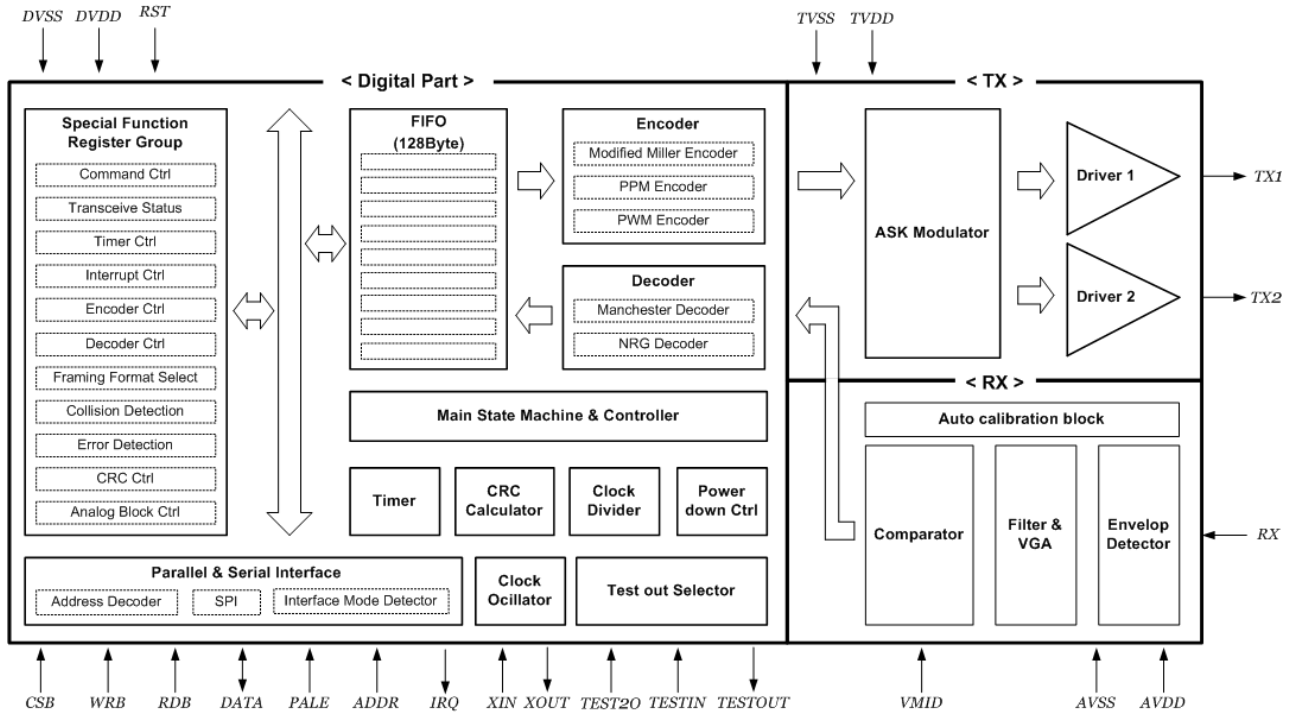

Electrical characteristics

Table 1. Operating condition range

Symbol	Parameter	MIN	TYP	MAX	UNIT
T_{op}	Operating temperature range	-25	+25	+85	°C
DVDD	Digital Power supply	2.9	3.3	3.6	V
AVDD	Analog Power supply	2.9	3.3	3.6	V
TVDD	Transmitter Power supply	2.9	3.3	3.6	V

Table 2. Current consumption

Symbol	Parameter	Conditions	MIN	TYP	MAX	UNIT
I_{DVDD}	Digital Supply current	Idle Command	5.0	7.5	9.5	mA
		Power Down mode	0.1	0.2	0.4	uA
I_{AVDD}	Analog Supply current	Receiver On	2.5	3.15	4.5	mA
		Power Down mode	0.01	0.05	0.5	uA
I_{TVDD}	Transmitter Supply current	Continuous Wave Antenna unconnected (TX1 and TX2 ON, CwConductance=3F)	110	130	150	mA
		Continuous Wave Antenna unconnected (TX1 ON and TX2 OFF, CwConductance=01)	24	28	33	mA
		TX1 and TX2 unconnected, TX1,2 disable / clock on	7	8	10	uA
		TX1 and TX2 unconnected, TX1,2 disable / clock off	0.01	0.011	0.013	uA
I_{ek}	Total Leakage current	Power down mode	0.1	0.35	1.0	uA
I_{op}	Total operating current	Operating mode (* Minimum power TX1 ON and TX2 OFF, CwConductance=01)	130 (34)	140 (38)	150 (44)	mA

Package information

TRH031M uses 32pin LQFP package. Package physical dimension is as below.

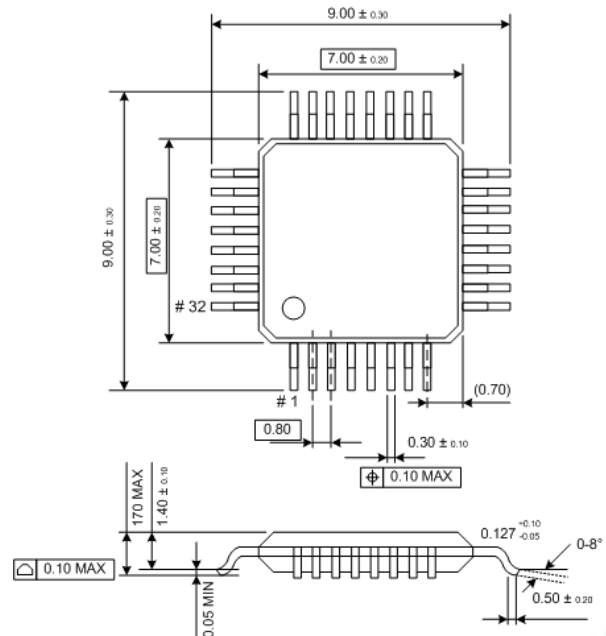
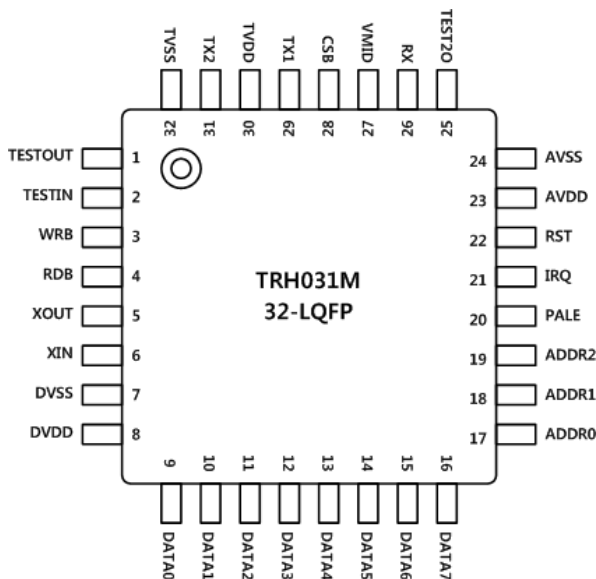

IT's RFID

Evaluation board

TRH031M evaluation is possible through RSK board offered with RSK100 Evaluation Kit.

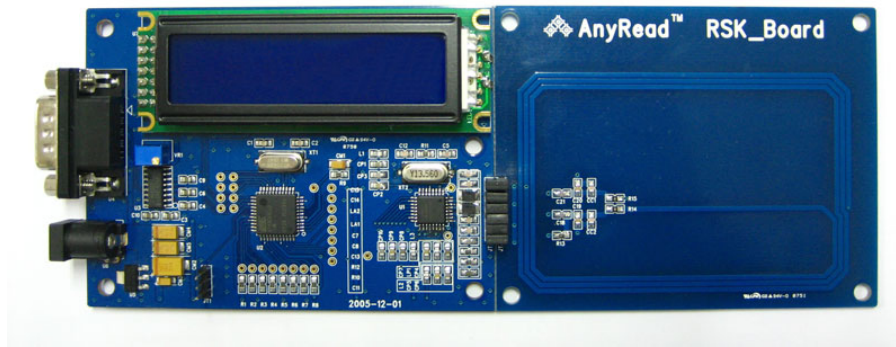

『 RSK 100 – TRH031M Evaluation system 』

Extended application

With TRH031M as a standard transceiver IC and with 50ohm matching system design method, user can develop reader system with extended RF signal line.

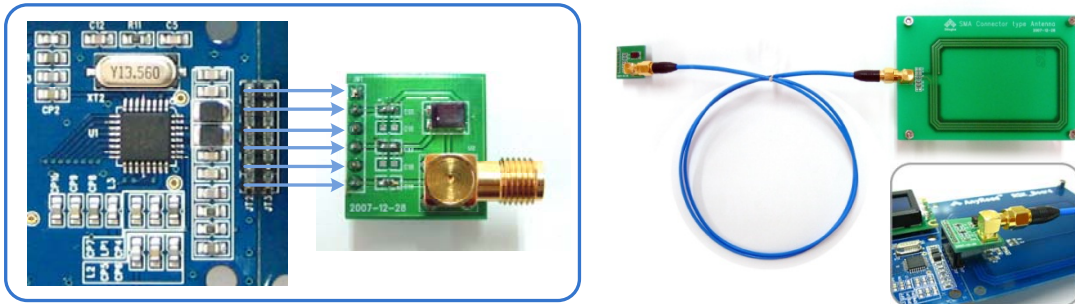

『 RFLEVK01 - 50ohm matching system 』

Legal Disclaimer

3ALogics shall not be liable for the incidental or consequential losses of damage to tangible property and injury in connection with the use of this device. Although the examples in this guide have been tested with care, they may contain errors and they are not guaranteed for any particular purpose. 3ALogics reserves rights to change any contents to this documents at anytime without any prior notice.

Contact

3ALogics Inc.
7th Fl., Hyundai-office Bldg.9-4, Sunae-dong, Bundang-gu,
Seongnam-si, Gyeonggi-do, 463-783 Korea

TEL : (82)-(31)-715-7117
FAX : (82)-(31)-719-7551

E-mail : rfd@3ALogics.com
Homepage: <http://www.3ALogics.com>

Printed in the Republic of Korea.