



	ESTECH Co., Ltd. Rm 1015, World Venture Center 11, 426-5 Gasan-dong, Guncheon-gu, Seoul, 158-803, Korea	  	Electromagnetic Interference Test Report

Test Report for FCC

FCC ID:TKWXPSM

Report Number		ESTF151109-004			
Applicant	Company name	Suprema Inc.			
	Address	16F Parkview Office Tower, Jeongja-dong, Bundang-gu, Seongnam, Gyeonggi, 463-863 Korea			
	Telephone	82-31-783-4505			
Product	Product name	RFID READER			
	Model No.	XPass S(XPSM)	Manufacturer	Suprema Inc.	
	Serial No.	NONE	Country of origin	Korea	
Test date	2011-09-02~2011-09-05		Date of issue	16-Sep-11	
Testing location	ESTECH Co., Ltd. 58-1 OSan-Ri Kanam-Myon, Yeosu-Gun, KyungKi-Do, Korea				
Standard	FCC PART 15C 2010 , ANSI C 63.4 2003				
Test item	<input checked="" type="checkbox"/> Conducted Emission	<input type="checkbox"/> Class A	<input checked="" type="checkbox"/> Class B	Test result	OK
	<input checked="" type="checkbox"/> Radiated Emission	<input type="checkbox"/> Class A	<input checked="" type="checkbox"/> Class B	Test result	OK
Measurement facility registration number		94696			
Tested by	Senior Engineer S.B.LEE  (Signature)				
Reviewed by	Engineering Manager J.M.Yang  (Signature)				
Abbreviation	OK, Pass = Complied, Fail = Failed, N/A = not applicable				
<p>* Note</p> <ul style="list-style-type: none"> - This test report is not permitted to copy partly without our permission - This test result is dependent on only equipment to be used - This test result based on a single evaluation of one sample of the above mentioned 					

Contents

1. Laboratory Information	3
2. Description of EUT	4
3. Test Standards	5
4. Measurement condition	6
5. 20dBm Bandwidth	8
5.1 Procedure	8
5.2 20dBm Bandwidth Set up	8
5.3 Measurement Data	8
6. Frequency Tolerance	9
6.1 Procedure	9
6.2 Test Equipments	9
6.3 Measurement Data	10
7. Measurement of radiated emission	11
7.1 Radiated emission limits, general requirements	11
7.2 Measurement equipment	11
7.3 Environmental conditions	11
7.4 Test data(9 kHz ~30 MHz)	12
7.5 Test data(30 MHz ~ 1 GHz)	13
8. Measurement of conducted emission	14
8.1 Measurement equipment	14
8.2 Environmental conditions	14
8.3 Test data	15
9. Photographs of test setup	16
10. Photographs of EUT	18

Appendix 1. Spectral diagram

Appendix 2. Antenna Requirement



1. Laboratory Information

1.1 General

This EUT (Equipment Under Test) has been shown to be capable of compliance with the applicable technical standards and is tested in accordance with the measurement procedures as indicated in this report. ESTECH Lab attests to accuracy of test data. All measurement reported herein were performed by ESTECH Co., Ltd.

ESTECH Lab assume full responsibility for the completeness of these measurements and vouch for the qualifications of all persons taking them.

1.2 Test Lab.

Corporation Name : ESTECH Co., Ltd.

Head Office : Rm 1015, World Venture Center II, 426-5, Gasan-dong, Geumcheon-gu, Seoul, Korea
(Safety & Telecom. Test Lab)

EMC Test Lab : 58-1 Osan-Ri, GaNam-Myon, YeoJoo-Gun, KyungKi-Do, Korea
97-1 Hoiuk-Ri Majang-Myon, Icheon-city, KyungKi-Do, Korea

1.3 Official Qualification(s)

KCC : Granted Accreditation from Ministry of Information & Communication for EMC, Safety and Telecommunication

KOLAS : Accredited Lab By Korea Laboratory Accreditation Schema base on CENELEC requirements

FCC : Filed Laboratory at Federal Communications Commission

VCCI : Granted Accreditation from Voluntary Control Council for Interference from ITE

2. Description of EUT

2.1 Summary of Equipment Under Test

Product : RFID READER
 Model Number : XPass S(XPSM)
 Serial Number : NONE
 Manufacturer : Suprema Inc.
 Country of origin : Korea
 Operating Frequency : 13.56 MHz
 Antenna Type : PCB Pattern Antenna
 Modulation Type : ASK
 Channel Spacing : 1
 Rating : Input : (100 – 240) Va.c., 1.0 A (50 – 60) Hz
 EUT input : 12 Vd.c., 2.5 A
 Receipt Date : 25-Aug-11
 X-tal lists : 25.00 MHz x 2ea, 13.56 MHz x 1ea, 32.768 kHz x 1ea

2.2 General descriptions of EUT

CPU	32 bit Micro-processor
Memory	8MB FLASH + 16MB SDRAM
RF Card	13.56 MHz Mifare (XPSM)
User Capacity	40000 user
Log Capacity	50000 log
Network interfaces	TCP/IP, RS485
IP Rate	IP 65 class
Sound	Multi-tone buzzer
LED	Multi-color LED
I/O	Relay x 1 Tamper x 1 Switch input x 2 Wiegand x 1
Power	12Vdc
Operating Temperature	-20 ~ 50°C
Size	80 x 120 x 11mm (W x H x D)
Certificates	CE, FCC, KCC, IP65

3. Test Standards

Test Standard : FCC PART 15 (2010)

This Standard sets out the regulations under which an intentional, unintentional, or incidental radiator may be operated without an individual license. It also contains the technical specifications, administrative requirements and other conditions relating to the marketing of Part 15 devices.

Test Method : ANSI C 63.4 (2003)

This standard sets forth uniform methods of measurement of radio-frequency (RF) signals and noise emitted from both unintentional and intentional emitters of RF energy in the frequency range 9 kHz to 40 GHz. Methods for the measurement of radiated and AC power-line conducted radio noise are covered and may be applied to any such equipment unless otherwise specified by individual equipment requirements. These methods cover measurement of certain devices that deliberately radiate energy, such as intentional emitters, but does not cover licensed transmitters. This standard is not intended for certification/approval of avionic equipment or for industrial, scientific, and medical (ISM) equipment. These methods apply to the measurement of individual units or systems comprised of multiple units.

Summary of Test Results

Applied Standard : 47 CFR Part 15, Subpart C				
Standard	Test Type	Result	Remark	Limit
15.207	AC Power Conducted Emission	Pass	Meet the requirement	
15.225(a)	Radiated Emission (13.553 ~13.567) MHz	Pass	Meet the requirement	15,848 uV/m at 30 m
15.225(b)	Radiated Emission (13.410 ~13.553 , 13.567 ~ 13.710) MHz	Pass	Meet the requirement	334 uV/m at 30 m
15.225(c)	Radiated Emission (13.110 ~13.410 , 13.710 ~ 14.010) MHz	Pass	Meet the requirement	106 uV/m at 30 m
15.225(d)	Apply section 15.209 (out side band of the 13.110 ~14.010) MHz	Pass	Meet the requirement	
15.225(e)	Frequency stability	Pass	Meet the requirement	
15.215(c)	20dB Bandwidth	Pass	Meet the requirement	

4. Measurement Condition

4.1 EUT Operation.

The EUT was measured by transmitter mode continuously.

4.2 Configuration and Peripherals

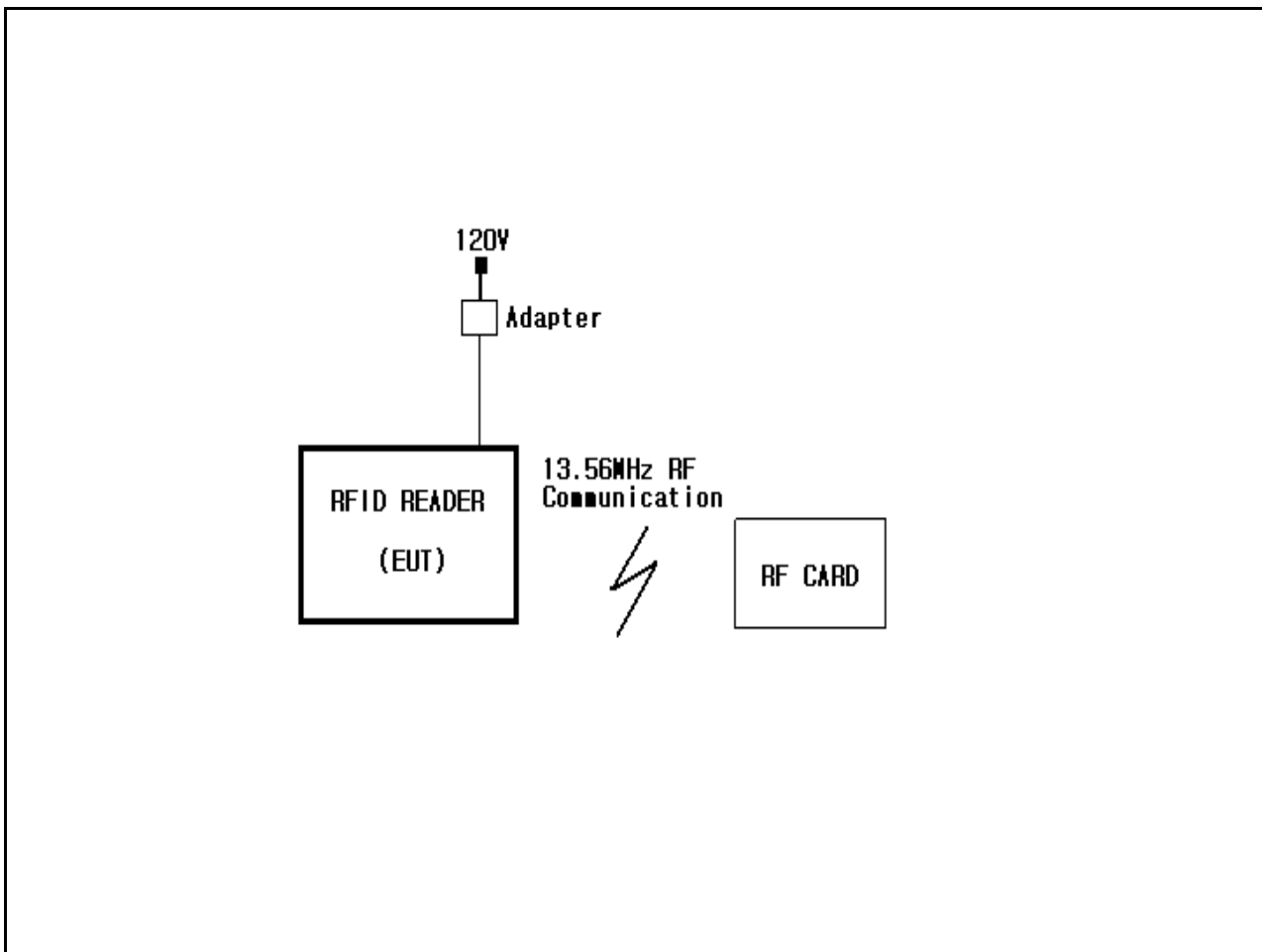

4.3 EUT and Support equipment

Equipment Name	Model Name	S/N	Manufacturer	Remark (FCC ID)
RFID READER	XPass S(XPSM)	NONE	Suprema Inc.	EUT
Adapter	JPW128KA1200N05	NONE	BridgePower Corp.	

4.4 Cable Connecting

Start Equipment		End Equipment		Cable Standard		Remark
Name	I/O port	Name	I/O port	Length	Shielded	
RFID READER	Power	Adapter	-	2	No	
RFID READER	13.56MHz RF Signal	RF CARD	13.56MHz RF Signal	-	-	



ESTECH Co., Ltd.

Rm 1015, World Venture Center II,
426-5 Gasan-dong, Guncheon-gu,
Seoul, 158-803, Korea



**Electromagnetic
Interference
Test Report**

5. 20 dB Bandwidth

5.1 Procedure

The measurement was performed in the antenna height to gain the maximum of Electric field strength

5.2 20dB Bandwidth setup

The spectrum analyzer is set to as following

RBW:10 Hz

VBW:300 KHz

Span:1 KHz

Sweep:suitable duration based on the EUT specification

20dB Bandwidth Test Instruments

Decription	Model	Serial Number	Cal. Due Data
Spectrum Analyzer	E4440A	US41421291	2-Feb-12

5.3 Measurement Data

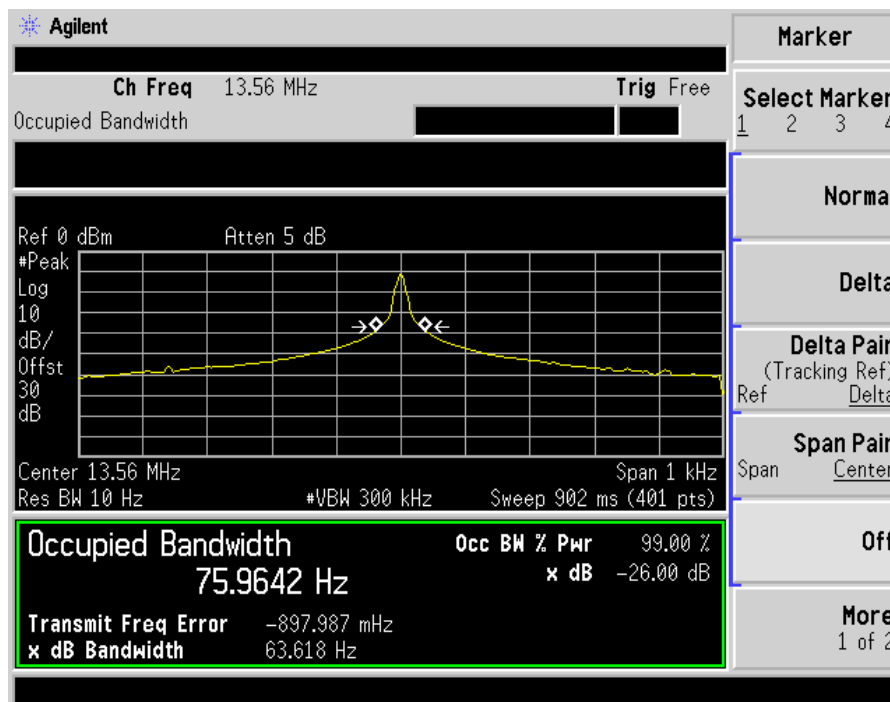

6. Frequency Tolerance

6 Procedure

The frequency stability of the transmitter is measured by:

- a) Temperature: The temperature is varied from -20 °C to +50 °C using an environmental chamber.
- b) Primary Supply Voltage: The primary supply voltage is varied from 85 % to 115 % of the voltage normally at the input to the device or at the power supply terminals if cables are not normally supplied.

The frequency tolerance of the carrier shall be maintained within ± 0.01 % of the operating frequency.

The following test equipments are used during test

Decription	Model	Serial Number	Cal. Due Data
Spectrum Analyzer	E4440A	US41421291	9-Sep-11
DC Power Supply	AK-3010	01000106	24-Feb-12
Temp./Humidity Chamber	SM-150-2	04-TH24	7-Feb-12

6.3 Measurement Data

Operating Frequency :	13,560,000 Hz
Reference Voltage :	12.00 Vdc
Deviation Limit :	± 0.01 %

Voltage (%)	Power (Vdc)	Temperature (°C)	Frequency (Hz)	Deviation
100	12.00	+20 °C (Ref)	13,560,305	-0.002249
100		-20	13,560,519	-0.003827
100		-10	13,560,501	-0.003695
100		0	13,560,664	-0.004897
100		10	13,560,714	-0.005265
100		20	13,560,305	-0.002249
100		25	13,560,866	-0.006386
100		30	13,560,785	-0.005789
100		40	13,560,672	-0.004956
100		50	13,560,561	-0.004137
85		10.2	20	13,560,688
115	13.8	20	13,560,420	-0.003097

7. Measurement of radiated disturbance

The EUT was placed on the top of a rotating table 0.8 m above the ground at a 3 m Open test site. The table was rotated 360° to determine the position of the highest radiation. Then antenna is a loop antenna is fixed at 1 m above the ground to determine the maximum value of the field strength. Both parallel and perpendicular of the antenna are set to make the measurement. For each suspected emission, the EUT was arranged to its worst case and then the table was turned from 0° to 360° to find the maximum reading. The test receiver system was set to Q-Peak Detect Function and Specified Bandwidth with Maximum Hold Mode.

7.1 Radiated emission limits, general requirements

Except as provided elsewhere in this Subpart, the emissions from an intentional radiator shall not exceed the field strength levels specified in the following table:

Frequency (MHz)	Field strength @30 m (uV/m)	Field strength @30 m (dBuV/m)	Field strength @3m (dBuV/m)
Below 13.110	30	29.5	69.5
13.110 ~13.410	106	40.5	80.5
13.410~13.553	334	50.5	90.5
13.553~13.567	15,848	84	124
13.567~13.710	334	50.5	90.5
13.710~14.010	106	40.5	80.5
Above 14.010	30	29.5	69.5

* dBuV/m=20*log(uV/m) * Distance factor=40dB / decade(15.31(f))

7.2 Measurement equipments

Equipment Name	Type	Manufacturer	Serial No.	Next Calibration date
Test Receive	ESVS10	Rohde & Schwarz	838562/002	27-Jan-12
Test Receive	ESPI7	Rohde & Schwarz	100185	27-Jan-12
Spectrum Analyzer	R3273	ADVANTEST	110600592	27-Jan-12
Logbicon Antenna	VULB9160	Schwarzbeck	3106	14-Apr-12
Horn Antenna	BBHA 9120 D	Schwarzbeck	352	22-Mar-12
Pre Amplifier	8447F	HP	2944A03711	11-Jan-12
PREAMPLIFIER	8449B	Sonoma Instrument	300884581	27-Jan-12
Loop Antenna	HFH2-Z2	Rohde & Schwarz	100188	29-Jul-12
Turn Table	2081-1.2M	EMCO	NONE	-
Antenna Mast	Jan-70	EMCO	0005-2205	-
ANT Mast Controller	2090	EMCO	9612-1202	-
Turn Table Controller	2090	EMCO	9612-1202	-

7.3 Environmental Condition

Test Place : Open site(3 m)
 Temperature (°C) : 24 °C
 Humidity (% R.H.) : 58 % R.H.



ESTECH Co., Ltd.

Rm 1015, World Venture Center II,
426-5 Gasan-dong, Guncheon-gu,
Seoul, 158-803, Korea



**Electromagnetic
Interference
Test Report**

7.4 Test data(9 kHz ~ 30 MHz)

Test Date : 2-Sep-11

Measurement Distance : 3 m

Reading (dB μ V)	Position (V/H)	Height (m)	Correction Factor			Result Value(Quasi-Peak)		
				Ant Factor (dB)	Cable (dB)	Limit (dB μ V/m)	Result (dB μ V/m)	Margin (dB)
Below 13.110 MHz								
Noise Floor	-	-	-	18.15	0.4	69.5	-	-
13.110 MHz to 13.410 MHz								
Noise Floor	-	-	-	18.15	0.4	80.5	-	-
13.410 MHz to 13.553 MHz								
Noise Floor	-	-	-	18.15	0.4	90.5	-	-
13.553 MHz to 13.567 MHz								
13.56	48.09	H	1.0	18.15	0.4	124.0	66.66	57.34
13.567 MHz to 13.710 MHz								
Noise Floor	-	-	-	18.15	0.4	90.5	-	-
13.710 MHz to 14.010 MHz								
Noise Floor	-	-	-	18.15	0.4	80.5	-	-
14.010 MHz to 30 MHz								
Noise Floor	-	-	-	18.15	0.4	69.5	-	-
14.010 MHz to 30 MHz								
Noise Floor	-	-	-	18.15	0.4	69.5	-	-
Remark	<ul style="list-style-type: none"> *There was no detected Restricted bands and Radiated suprious emission below 30MHz. *The 30m limit was converted to 3m Limit using square factor(x) as it was found by measurements as follows: *3 m Limit(dBuV/m) = 20log(X)+40log(30/3)= 20log(15848)+40log(30/3) = 124dBuV *Detector : Q.P(9kHz) 							

7.5 Test data(30 MHz ~ 1 000 MHz)

Test Date : 5-Sep-11

Measurement Distance : 3 m

Frequency (MHz)	Reading (dB μ V)	Position (V/H)	Height (m)	Correction Factor		Result Value(Qeasi-Peak)		
				Ant Factor (dB)	Cable (dB)	Limit (dB μ V/m)	Result (dB μ V/m)	Margin (dB)
30.00	16.82	V	1.0	10.53	2.06	40.00	29.41	10.59
40.68	16.72	V	1.0	10.94	2.06	40.00	29.72	10.28
61.91	18.53	V	1.0	10.88	2.06	40.00	31.47	8.53
74.63	13.37	H	4.0	9.06	2.06	40.00	24.49	15.51
117.20	11.31	V	1.0	10.59	2.30	43.50	24.2	19.3
133.33	13.08	V	1.0	11.93	2.53	43.50	27.55	15.95
166.30	12.61	H	3.0	12.30	3.00	43.50	27.91	15.59
233.35	15.77	H	2.5	11.32	3.59	46.00	30.68	15.32
250.02	15.85	V	1.0	11.57	3.65	46.00	31.07	14.93
312.02	10.53	H	2.1	14.16	3.84	46.00	28.53	17.47
366.73	9.40	H	1.0	15.42	3.99	46.00	28.81	17.19
432.12	9.99	V	1.0	17.33	4.35	46.00	31.67	14.33
500.00	13.75	V	1.0	18.23	4.93	46.00	36.91	9.09
Remark	H : Horizontal, V : Vertical *CL = Cable Loss-Amplifier Gain(In case of above1000MHz) *CL = Cable Loss(In case of below1000MHz) *The resolution bandwidth and video bandwidth of test receiver/spectrum analyzer is 120kHz for Quasi-peak detection at frequency below 1GHz. *The resolution bandwidth of test receiver/spectrum analyzer is 1MHz and the video bandwidth is 10Hz for Average detection at frequency above 1GHz.							

8. Measurement of conducted disturbance

The continuous disturbance voltage of AC Mains in the frequency from 0.15 MHz to 30 MHz was measured in accordance to FCC Part 15 (2010) & ANSI C 63.4 (2003) The test setup was made according to FCC Part 15 (2010) & ANSI C 63.4 (2003) in a shielded Room. The EUT was placed on a non-conductive table at least 0.8 m above the ground plan. A grounded vertical reference plane was positioned in a distance of 0.4 m from the EUT. The distance from the EUT to other metal surfaces was at least 0.8 m. The EUT was only earthen by its power cord through the line impedance stabilizing network. The power cord has been bundled to a length of 1.0 m. The test receiver with Quasi Peak detector complies with CISPR 16.

8.1 Measurement equipments

Equipment Name	Type	Manufacturer	Serial No.	Next Calibration date
LISN	ESH2-Z5	POLARAD	872461/048	11-Jan-12
TEST Receiver	ESHS 30	Rohde & Schwarz	828765/002	17-Dec-11
Pulse Limiter	ESH3-Z2	Rohde & Schwarz	NONE	21-Mar-12

8.2 Environmental Condition

Test Place : Shielded Room

Temperature (°C) : 22 °C

Humidity (% R.H.) : 45 % R.H.

8.3 Test data

Test Date : 2-Sep-11

Frequency (MHz)	Correction Factor		Line (H/N)	Quasi-peak Value			Average Value		
	Lisn (dB)	Cable (dB)		Limit (dB μ V)	Reading (dB μ V)	Result (dB μ V)	Limit (dB μ V)	Reading (dB μ V)	Result (dB)
0.19	0.10	0.2	N	64.04	43.65	43.95	54.04		
0.25	0.03	0.2	H	61.76	39.50	39.73	51.76		
0.26	0.10	0.2	N	61.43	39.06	39.36	51.43		
0.32	0.03	0.2	H	59.71	36.10	36.33	49.71		
0.39	0.08	0.2	H	58.06	36.32	36.60	48.06		
0.45	0.08	0.2	H	56.88	35.57	35.85	46.88		
0.59	0.15	0.2	H	56.00	39.41	39.76	46.00		
0.65	0.15	0.2	H	56.00	41.31	41.66	46.00		
0.84	0.17	0.2	H	56.00	33.21	33.58	46.00		
0.97	0.25	0.2	H	56.00	34.46	34.91	46.00		
1.03	0.27	0.2	H	56.00	33.51	33.98	46.00		
1.10	0.34	0.3	H	56.00	34.25	34.89	46.00		
11.26	1.75	1.0	H	60.00	28.50	31.25	50.00		
12.89	1.71	1.0	H	60.00	30.94	33.65	50.00		
15.24	1.67	1.1	H	60.00	27.75	30.52	50.00		
17.45	1.37	1.2	H	60.00	28.07	30.61	50.00		
21.30	1.55	1.3	N	60.00	29.21	32.06	50.00		
21.82	1.59	1.3	H	60.00	30.20	33.09	50.00		
Remark	H : Hot Line, N : Neutral Line								

9. Photographs of test setup

9.1 Setup for Radiated Test

[Test setup for below 30 MHz]



[Test setup for above 30 MHz]



9.2 Setup for Conducted Test : 0.15 MHz ~ 30 MHz

[Front]



[Rear]





ESTECH Co., Ltd.

Rm 1015, World Venture Center II,
426-5 Gasan-dong, Guncheon-gu,
Seoul, 158-803, Korea



**Electromagnetic
Interference
Test Report**

10.0 Photographs of EUT

[Front]



[Rear]





ESTECH Co., Ltd.

Rm 1015, World Venture Center II,
426-5 Gasan-dong, Guncheon-gu,
Seoul, 158-803, Korea



**Electromagnetic
Interference
Test Report**

10.1 Photographs of EUT

[Front]



[Label]



*NEUTRAL

ES TECH
NEUTRAL LINE

02 Sep 2011 23:59

EUT: XPass S(XPSM)
Manuf:
Op Cond: 120 V
Operator: S.B.LEE / Engineer
Test Spec: CLASS B
Comment:

Result File: 110904_n.dat : ESTF151109-004

Scan Settings (1 Range)

Frequencies			Receiver Settings					
Start	Stop	Step	IF BW	Detector	M-Time	Atten	Preamp	OpRge
150kHz	30MHz	0.8%	10kHz	PK+AV	10msec	Auto	OFF	60dB

Final Measurement: Detectors: X QP / + AV
Meas Time: 1sec
Subranges: 25
Acc Margin: 0 dB

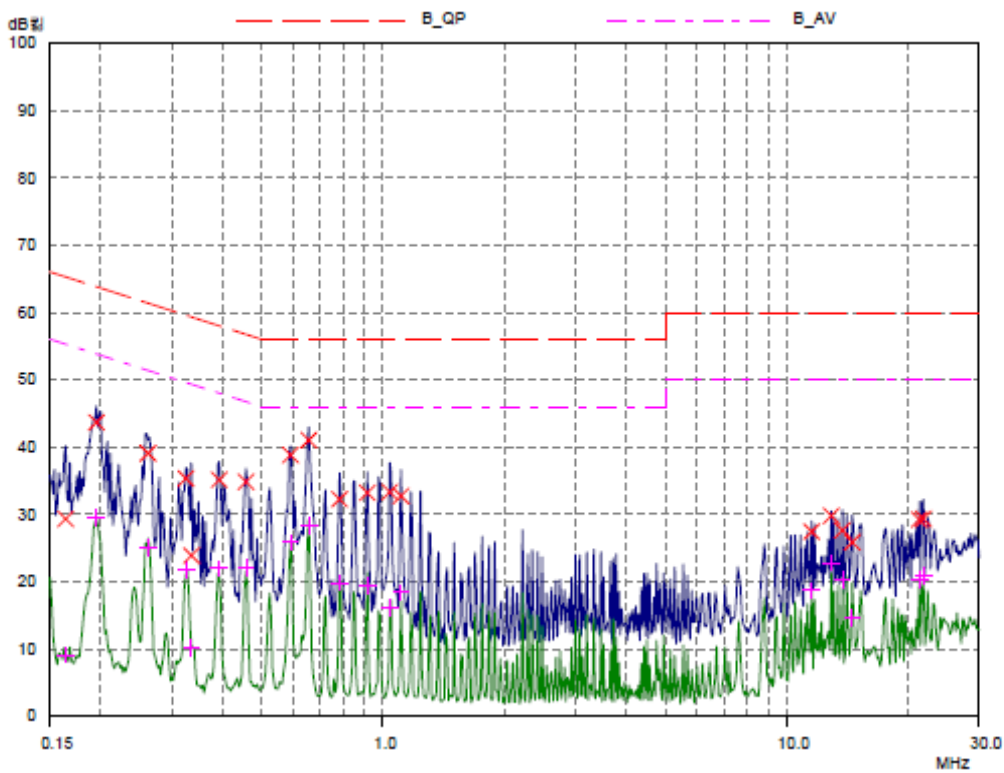

Appendix 1. Spectral diagram

*HOT

ES TECH
HOT LINE

03 Sep 2011 00:05

EUT: XPass S(XPSM)
 Manuf:
 Op Cond: 120 V
 Operator: S.B.LEE / Engineer
 Test Spec: CLASS B
 Comment:

Result File: 110904_h.dat : ESTF151109-004

Scan Settings (1 Range)

Frequencies			Receiver Settings						
Start	Stop	Step	IF BW	Detector	M-Time	Atten	Preamp	OpRge	
150kHz	30MHz	0.8%	10kHz	PK+AV	10msec	Auto	OFF	60dB	

Final Measurement: Detectors: X QP / + AV
 Meas Time: 16sec
 Subranges: 25
 Acc Margin: 0 dB

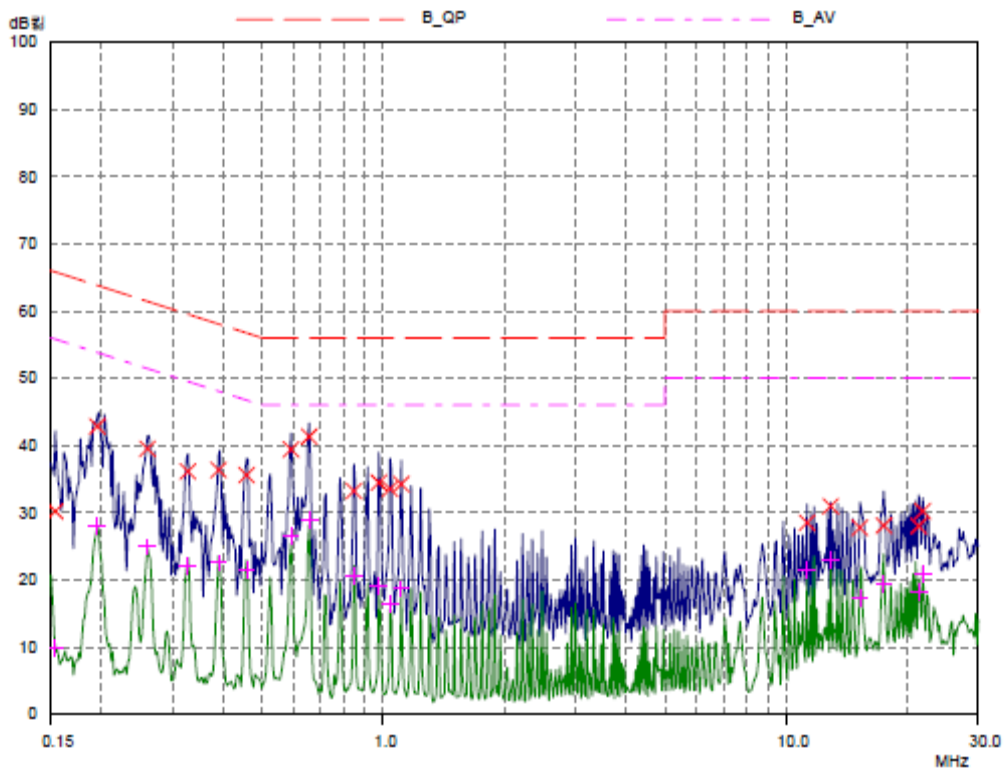

Appendix 2. Antenna Requirement

Regulation

According to §15.203, an intentional radiator shall be designed to ensure that no antenna other than that furnished by the responsible party shall be used with the device. The use of a permanently attached antenna or of an antenna that uses a unique coupling to the intentional radiator shall be considered sufficient to comply with the provisions of this Section. The manufacturer may design the unit so that a broken antenna can be replaced by the user, but the use of a standard antenna jack or electrical connector is prohibited.

Result

-Complied

The transmitter has an integral PCB pattern antenna.