



**Test Report for FCC & ISED**

FCC ID : TKWXP2-MDPB2  
IC : 23080-XP2MDPB

Report Number		ESTRFC2206-004	
Applicant	Company name	Suprema Inc	
	Address	17F-5, Parkview Office Tower, 248, Jeongjail-ro, Bundang-gu, Seongnam-si, Gyeonggi-do, South Korea	
	Telephone	+82-31-710-5633	
	Contact person	Jae-Won Lee, Han-Chul Kim	
Product	Product name	Xpass 2	
	Factory address	17F-5, Parkview Office Tower, 248, Jeongjail-ro, Bundang-gu, Seongnam-si, Gyeonggi-do, South Korea	
	Model No.	XP2-MDPB	Manufacturer Suprema Inc
	Serial No.	NONE	Country of origin KOREA
Test date	02-JUN-22 ~ 08-JUN-22	Date of issue	28-Jun-22
Testing location	140-16, Eongmalli-ro, Majang-myeon, Icheon-si, Gyeonggi-do, Rep. of Korea		
Standard	FCC PART 15 Subpart C (15.247), ANSI C 63.10(2013), KDB 558074 D01v05r02, RSS-247(2017)		
Measurement facility registration number	659627, ISED : 4475A		
Tested by	Senior Engineer H.G. Lee	(Signature)	
Reviewed by	Engineering Manager I.K Hong	(Signature)	
Abbreviation	OK, Pass = Passed, Fail = Failed, N/A = not applicable		
<p>* Note</p> <ul style="list-style-type: none"> <li>- This test report is not permitted to copy partly without our permission</li> <li>- This test result is dependent on only equipment to be used</li> <li>- This test result based on a single evaluation of one sample of the above mentioned</li> <li>- This test report is not related to KOLAS accreditation</li> </ul>			

## Contents

1. Laboratory Information .....	3
2. Description of EUT .....	4
3. Test Standards .....	6
4. Measurement condition .....	6
5. DTS bandwidth .....	11
5.1 Test procedure .....	11
5.2 Test instruments and measurement setup .....	11
5.3 Measurement results .....	11
5.4 Trace data .....	12
6. Maximum Peak Output Power .....	14
6.1 Test procedure .....	14
6.2 Measurement results .....	14
7. Maximum conducted (average) output power .....	15
7.1 Test procedure .....	15
7.2 Measurement results .....	15
8. Maximum power spectral density level in the fundamental emission .....	16
8.1 Test procedure .....	16
8.2 Test instruments and measurement setup .....	16
8.3 Measurement results .....	16
8.4 Trace data .....	17
9. Emissions in non-restricted frequency bands .....	19
9.1 Test procedure .....	19
9.2 Test instruments and measurement setup .....	19
9.3 Measurement results of band-edge & out of emission .....	19
9.4 Trace data of band-edge & Out of Emission.....	20
10. Measurement of radiated emission .....	23
10.1 Measurement equipment .....	23
10.2 Environmental conditions .....	23
10.3 Measurement Instrument setting for Radiated Emission .....	24
10.4 Test Data.....	25
11. Measurement of conducted emission .....	37
11.1 Measurement equipment .....	37
11.2 Environmental conditions .....	37
11.3 Test Data.....	38

Appendix 1. Special diagram

Appendix 2. Antenna Information



## 1. Laboratory Information

### 1.1 General

This EUT (Equipment Under Test) has been shown to be capable of compliance with the applicable technical standards and is tested in accordance with the measurement procedures as indicated in this report.

ESTECH Lab attests to accuracy of test data. All measurement reported herein were performed by ESTECH Co., Ltd.

ESTECH Lab assume full responsibility for the completeness of these measurements and vouch for the qualifications of all persons taking them.

### 1.2 Test Lab.

Corporation Name : ESTECH Co., Ltd.

Head Office : Suite 1015 World Meridian II, 123 Gasan Digital 2-ro, Geumcheon-gu, Seoul 153-759, R. O. Korea

EMC/Telecom/Safety Test Lab :140-16, Eongmalli-ro, Majang-myeon, Icheon-si,  
Gyeonggi-do, Rep. of Korea

### 1.3 Official Qualification(s)

MSIP : Granted Accreditation from Ministry of Information & Communication for EMC, Safety and Telecommunication

KOLAS : Accredited Lab By Korea Laboratory Accreditation Schema base on CENELEC requirements

FCC : Conformity Assessment Body(CAB) with registration number 659627 under APEC TEL MRA between the RRA and the FCC

VCCI : Granted Accreditation from Voluntary Control Council for Interference from ITE

## 2. Description of EUT

### 2.1 Summary of Equipment Under Test

Modulation Type	: Bluetooth (GFSK)
Transfer Rate	: 1 Mbps
Number of Channel	: 40 ch
PEAK Output Power	: GFSK : 0.86 mW
Rating	: INPUT: AC(100 – 240) V, (50–60)Hz, 1.7 A : OUTPUT: DC 24 V, 2.5 A
Receipt Date	: 19-May-22
X-tal list(s) or Frequencies generated	: The highest operating frequency is 2480 MHz(Bluetooth) : Bluetooth : 2.4 GHz

### 2.2 General descriptions of EUT

Category	Feature	Description
Credential	LF card option	EM
	HF card option	MIFARE, MIFARE Plus, DESFire/EV1, Felica
	NFC card	Supported
	BLE card	Supported
	RF read range*	MIFARE/DESFire/EM : 50 mm, Felica: 30 mm
General	CPU	1 GHz
	Memory	4 GH Flash + 64 MB RAM
	LED	Multi-color
	Sound	Multi-tone Buzzer
	Operating temperature	-35 °C ~ 65 °C
	Storage temperature	-40 °C ~ 70 °C
	Operating humidity	0 % – 95 %, non-condensing
	Storage humidity	0 % – 95 %, non-condensing
	Dimension(W X H X D)	80 mm x 130 mm x 25 mm
	Weight	Device: 220 g Bracket: 52g (including washer and bolt)
	IP rating	IP65, IP67
	IK rating	IK08
	Certificates	CE, FCC, KC, RoHS, REACH, WEEE, SIG

Category	Feature	Description
Capacity	Max. User	200,000
	Max. card	200,000
	Max. Text Log	1,000,000
Interface	Wi-Fi	Not supported
	Ethernet	supported (10/100 Mbps, auto MDI/MDI-X)
	RS-485	1 ch Master or Slave (Selectable)
	Wiegand	1 ch input or output (Selectable)
	TTL input	2 ch input
	Relay	1 Relay
	PoE	supported (IEEE 802.3af compliant)
	Tamper	supported
Electrical	Power	Voltage:DC 12 V, Current: Max, 500 mA or Voltage: DC 24 V, Current: Max. 250 mA * Use 12 VDC, 1 A / 24 VDC, 0.5 A power supply
	Switch input VIH	Min. 3 V Max. 5 V
	Switch input VIL	Max. 1 V
	Switch Pull-up resistance	4.7 k $\Omega$ (The input ports are pulled up with 4.7 k $\Omega$ .)
	Wiegand output VoH	Min. 4.8 V
	Wiegand output VoL	Max. 0.2 V
	Wiegand output Pull-up resistance	Internally pulled up with 1 k $\Omega$
	Relay	Voltage:Max. 30 VDC, Current : Max. 2 A

### 3. Test Standards

#### Test Standard : FCC PART 15 Subpart C (15.247)& RSS-247

This Standard sets out the regulations under which an intentional, unintentional, or incidental radiator may be operated without an individual license. It also contains the technical specifications, administrative requirements and other conditions relating to the marketing of Part 15 devices.

#### Test Method : ANSI C 63.10 (2013) & KDB558074 D01v05r02

This standard sets forth uniform methods of measurement of radio-frequency (RF) signals and noise emitted from both unintentional and intentional emitters of RF energy in the frequency range 9 kHz to 40 GHz. Methods for the measurement of radiated and AC power-line conducted radio noise are covered and may be applied to any such equipment unless otherwise specified by individual equipment requirements. These methods cover measurement of certain devices that deliberately radiate energy, such as intentional emitters, but does not cover licensed transmitters. This standard is not intended for certification/approval of avionic equipment or for industrial, scientific, and medical (ISM) equipment. These methods apply to the measurement of individual units or systems comprised of multiple units.

#### Summary of Test Results

Applied Standard : 47 CFR Part 15 Subpart C & RSS-247				remark
Standard	Test Type	Result	Remark	Limit
15.207 & RSS-GEN	AC Power Conducted Emission	Pass	Meet the requirement	
15.205 & 15.209 & RSS-247	Restricted band / Intentional Radiated Emission	Pass	Meet the requirement	
15.247(a)(2) & RSS-247 & RSS-GEN	6 dB Bandwidth	Pass	Meet the requirement	Min. 500 kHz
	Occupied Bandwidth			
15.247(b)(3) & RSS-247	Maximum Peak /Average output power	Pass	Meet the requirement	Max. 30 dBm
15.209 & RSS-247	Transmitter Radiated Emission	Pass	Meet the requirement	Table 15.209
15.247(e) & RSS-247	Power Spectral Density	Pass	Meet the requirement	Max. 8 dBm
15.247(d) & RSS-247	Band Edge Measurement	Pass	Meet the requirement	20 dB less

## 4. Measurement Condition

### 4.1 EUT Operation

#### a. Channel

Ch.	Frequency	Ch.	Frequency
0	2402 MHz	...	...
1	2404 MHz	36	2474 MHz
2	2406 MHz	37	2476 MHz
3	2408 MHz	38	2478 MHz
...	...	39	2480 MHz
11	2428 MHz		
...	...		
19	2440 MHz		

b. Measurement Channel : Bluetooth : Low(2402 MHz), Middle(2440 MHz), High(2480 MHz)

c. Test Mode : Continuous Output, GFSK

d. Test rate : 1 Mbps

## 4.2 EUT Operation.

- The EUT was in the following operation mode during all testing
  - \* Bluetooth operation check
  - \* Transmit mode were measured each channels(Low, Middle, High)
  - \* The EUT was measured up to tenth harmonic or 40 GHz of the highest operating frequencies.

## 4.3 Configuration and Peripherals

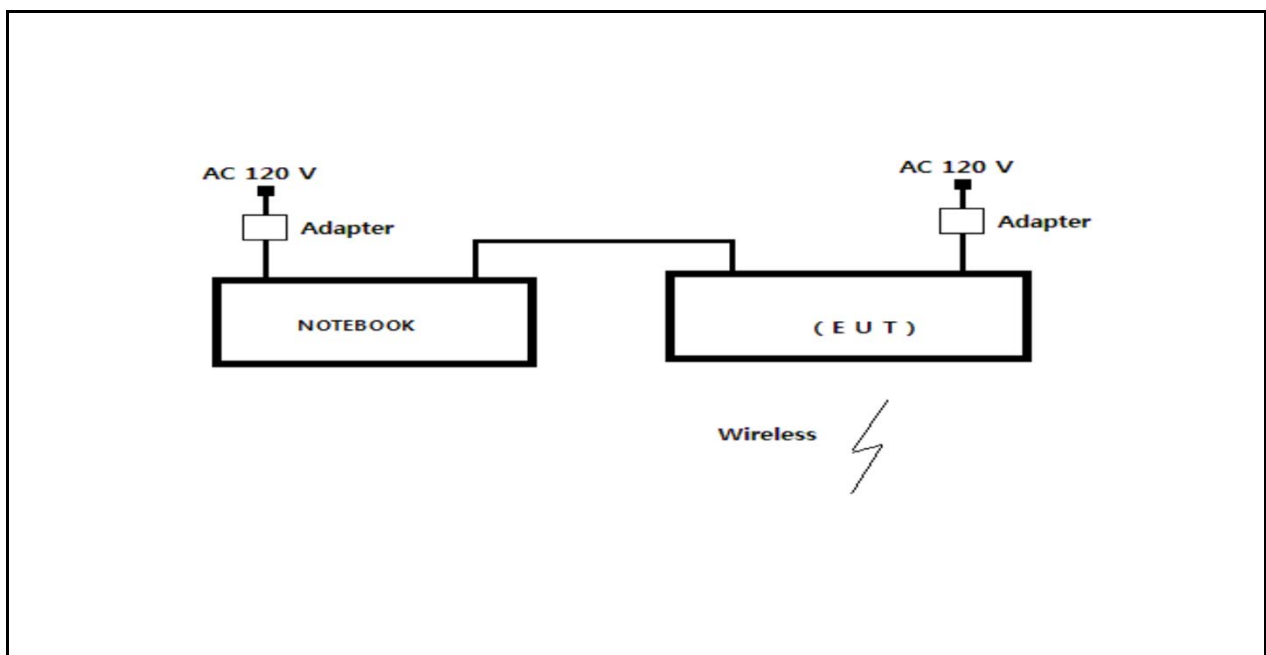



#### 4.4 EUT and Support equipment

Equipment Name	Model Name	S/N	Manufacturer	Remark (FCC ID)
Xpass 2	XP2-MDPB	NONE	Suprema Inc	EUT
Notebook	80XL	NONE	LcFc(hefei) electronics technology Co., Ltd.	
Adapter	KPL-060M-VI	NONE	Channel Well Technology (Guangzhou) Co.,Ltd.	

#### 4.5 Cable Connecting

Start Equipment		End Equipment		Cable Standard		Remark
Name	I/O port	Name	I/O port	Length	Shielded	
Xpass 2	Power	Adapter	-	2.0	Unshielded	
Xpass 2	USB	Notebook	USB	2.0	Unshielded	
Notebook	Power	Adapter	-	2.0	Unshielded	

## 4.6 DUTY CYCLE OF TEST SIGNAL

Duty cycle is < 98%, duty factor shall be considered.

duty cycle =  $0.102/0.626=0.164$ , duty factor =  $10*\log(1/0.164)=7.86$

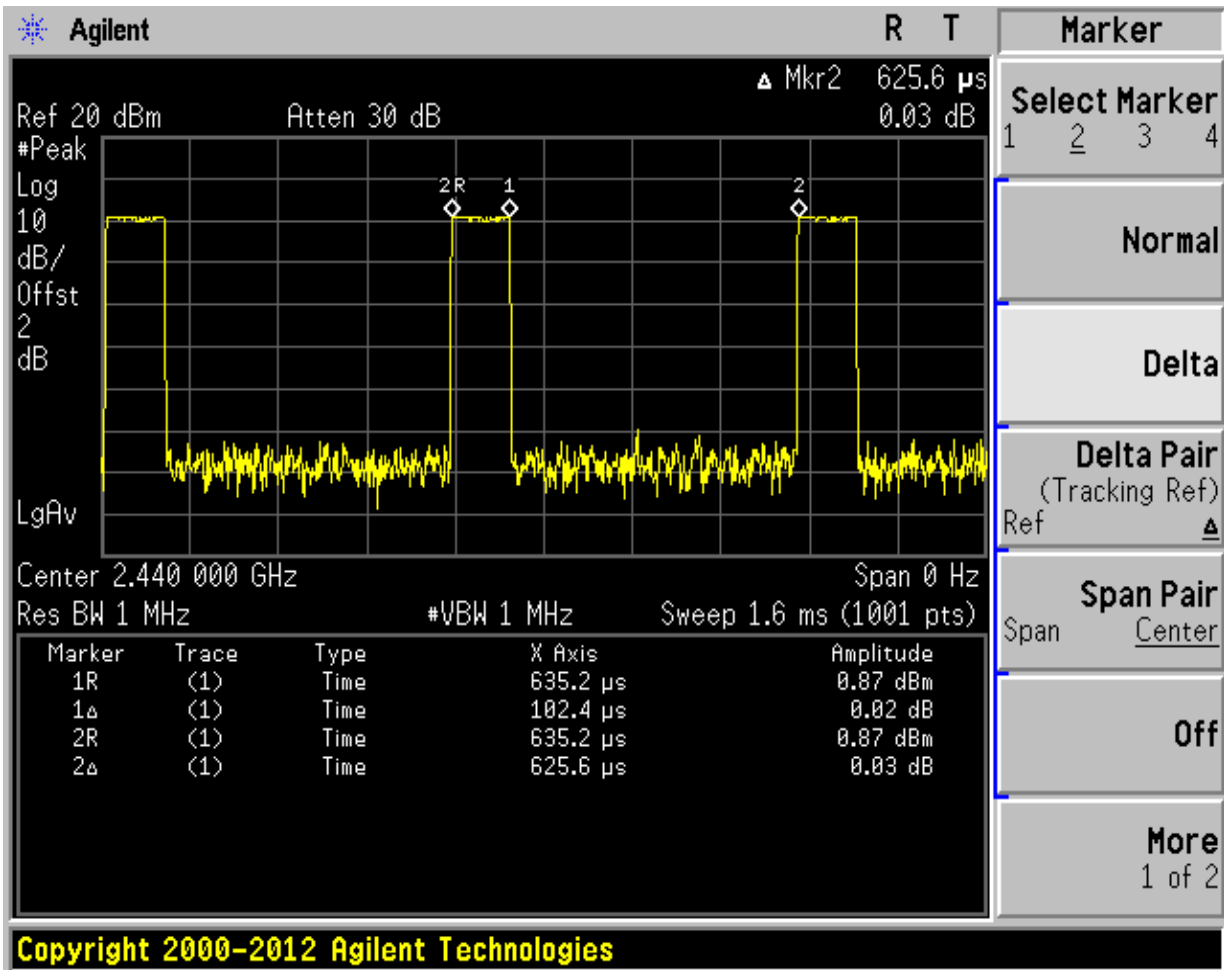



## 5. DTS bandwidth & 99 % Occupied Bandwidth

### 5.1 Test procedure

§ 15.247 (a)(2), RSS-247 §5.2, RSS-Gen §6.7

Systems using digital modulation techniques may operate in the 902–928MHz, 2400–2483.5MHz, and 5725–5850MHz bands. The minimum 6 dB bandwidth shall be at least 500 KHz.

### 5.2 Test instruments and measurement setup

The automatic bandwidth measurement capability of an instrument may be employed using the X dB bandwidth mode with X set to 6 dB, if the functionality described above (i.e., RBW = 100 kHz, VBW ≥ 3 X RBW, peak detector with maximum hold) is implemented by the instrumentation function. When using this capability, care shall be taken so that the bandwidth measurement is not influenced by any intermediate power nulls in the fundamental emission that might be ≥ 6 dB.

Limits : FCC § 15.247(a)(2)

#### 6dB Bandwidth Test Instruments

Description	Model	Serial Number	Cal. Due Date
Spectrum Analyzer	E4440A	US42041291	2022-11-29
RF Cable	Length: 30 cm	–	
–Spectrum Analyzer <=> EUT	Loss: 2 dB	–	

### 5.3 Measurement results

EUT	Xpass 2	MODEL	XP2-MDPB
MODE	GFSK	ENVIRONMENTAL CONDITION	22.3 °C, 44.6 % R.H.
INPUT POWER	DC 24.0 V		

Channel Frequency (MHz)	99 % Occupied Bandwidth(MHz)	Bandwidth at 6dB below(MHz)	Minimum Limit (MHz)	PASS/FAIL
2402	1.04	0.70	0.5	PASS
2440	1.03	0.68	0.5	PASS
2480	1.04	0.69	0.5	PASS

5.4 Trace data  
(ch\_0)  
99% OBW



6dB below

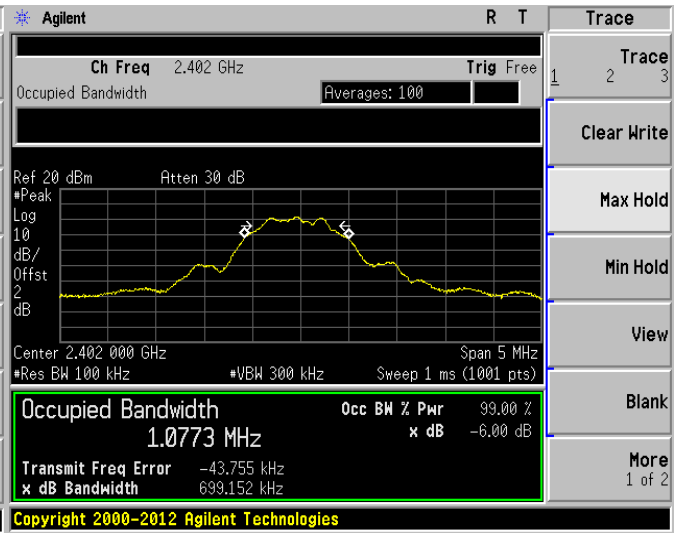

(ch\_19)

99% OBW

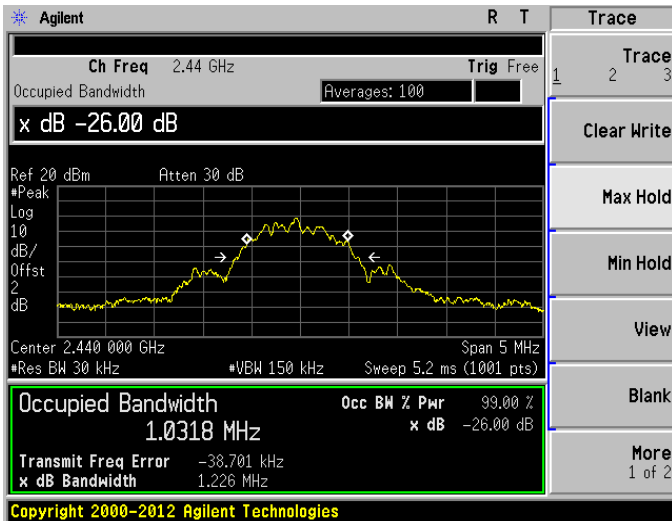

6dB below

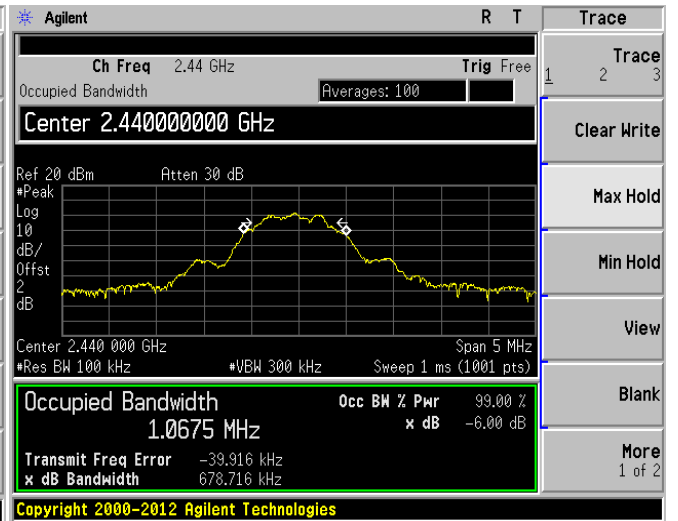



**Estech**  
your best partner

(ch\_39)

99% OBW

6dB below

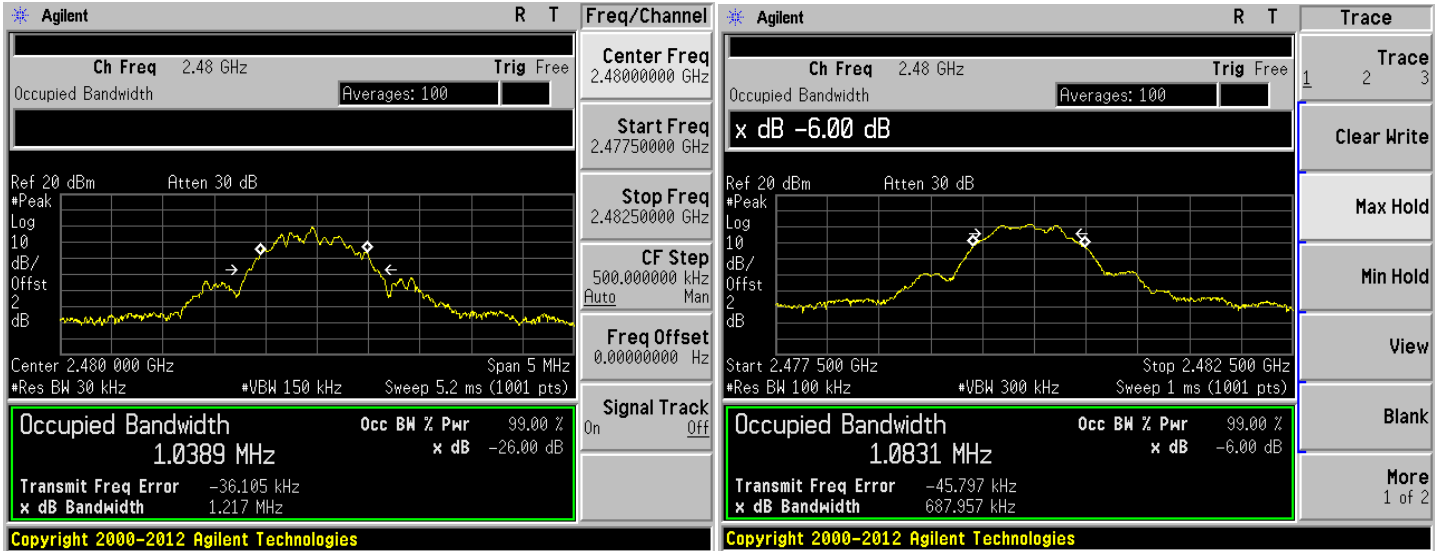

## 6. Maximum peak conducted output power

### 6.1 Test procedure

The transmitter antenna terminal is connected to the input of a Power Sensor. Measurement is made while EUT is operating in transmission mode at the appropriate center frequency. The maximum peak output power measurement is 30 dBm.

Limits : FCC § 15.247 RSS 247 section 5.4 d

#### Maximum Peak Output Power Test Instruments

Description	Model	Serial Number	Cal. Due Date
Power Meter	N1921A	MY45100570	2022-11-29
Power Sensor	N1921A	MY45240427	2022-11-29
Power Meter <=> EUT	Loss: 2 dB	-	

### 6.2 Measurement results

EUT	Xpass 2	MODEL	XP2-MDPB
MODE	GFSK	ENVIRONMENTAL CONDITION	22.3 °C, 44.6 % R.H.
INPUT POWER	DC 24.0 V		

CHANNEL	Channel Requency (MHz)	Conducted Power Output(dBm)			Limit[1W] (dBm)	PASS/FAIL
		Detector	(dBm)	(mW)		
0	2 402	PEAK	-1.08	0.78	30.0	PASS
19	2 440	PEAK	-1.17	0.76	30.0	PASS
39	2 480	PEAK	-0.65	0.86	30.0	PASS



## 7. Maximum conducted (average) output power

### 7.1 Test procedure

The transmitter antenna terminal is connected to the input of a Power Sensor. Measurement is made while EUT is operating in transmission mode at the appropriate center frequency. The maximum Average output power measurement is 30 dBm.

Limits : FCC § 15.247 & RSS 247 section 5.4 d

#### Maximum conducted (average) output power Test Instruments

Description	Model	Serial Number	Cal. Due Date
Power Meter	N1921A	MY45100570	2022-11-29
Power Sensor	N1921A	MY45240427	2022-11-29
Power Meter <=> EUT	Loss: 2 dB	-	

### 7.2 Measurement results

EUT	Xpass 2	MODEL	XP2-MDPB
MODE	GFSK	ENVIRONMENTAL CONDITION	22.3 °C, 44.6 % R.H.
INPUT POWER	DC 24.0 V		

CHANNEL	Channel Requency (MHz)	Conducted Power Output(dBm)			Measured + Duty Cycle(dBm)	Measured + Duty Cycle(mW)
		Detector	(dBm)	Duty Cycle		
0	2 402	AVG	-9.00	7.86	-1.14	0.77
19	2 440	AVG	-9.08	7.86	-1.22	0.76
39	2 480	AVG	-8.57	7.86	-0.71	0.85

## 8. Maximum power spectral density level in the fundamental emission

### 8.1 Test procedure

KDB 558074 D01 DTS Meas Guidance V05r02 10.2 Method PKPSD (peak PSD) & RSS 247 section 5.2

### 8.2 Test instruments and measurement setup

This procedure shall be used if maximum peak conducted output power was used to demonstrate compliance, and is optional if the maximum conducted (average) output power was used to demonstrate compliance.

- a) Set analyzer center frequency to DTS channel center frequency.
- b) Set the span to 1.5 times the DTS bandwidth.
- c) Set the RBW to:  $3 \text{ kHz} \leq \text{RBW} \leq 100 \text{ kHz}$ .
- d) Set the VBW  $\geq 3 \times \text{RBW}$
- e) Detector = peak.
- f) Sweep time = auto couple.
- g) Trace mode = max hold.
- h) Allow trace to fully stabilize.
- i) Use the peak marker function to determine the maximum amplitude level within the RBW.
- j) If measured value exceeds limit, reduce RBW (no less than 3 kHz) and repeat.

Limits FCC § 15.247

#### The peak power density Test Instruments

Description	Model	Serial Number	Cal. Due Date
Spectrum Analyzer	E440A	US42041291	2022-11-29
RF Cable	Length: 30 cm	–	
–Spectrum Analyzer <=> EUT	Loss: 2 dB	–	

### 8.3 Measurement results

EUT	Xpass 2	MODEL	XP2-MDPB	
MODE	GFSK	ENVIRONMENTAL CONDITION	22.3 °C, 44.6 % R.H.	
INPUT POWER	DC 24.0 V			
CHANNEL	Channel Frequency (MHz)	Measured Power Spectral Density (dBm)	Maximum Permissible Power Density (dBm/3kHz)	Margin
0	2 402	-16.35	8.0	24.35
19	2 440	-16.22	8.0	24.22
39	2 480	-16.09	8.0	24.09



### 8.4 Trace data (ch\_0)

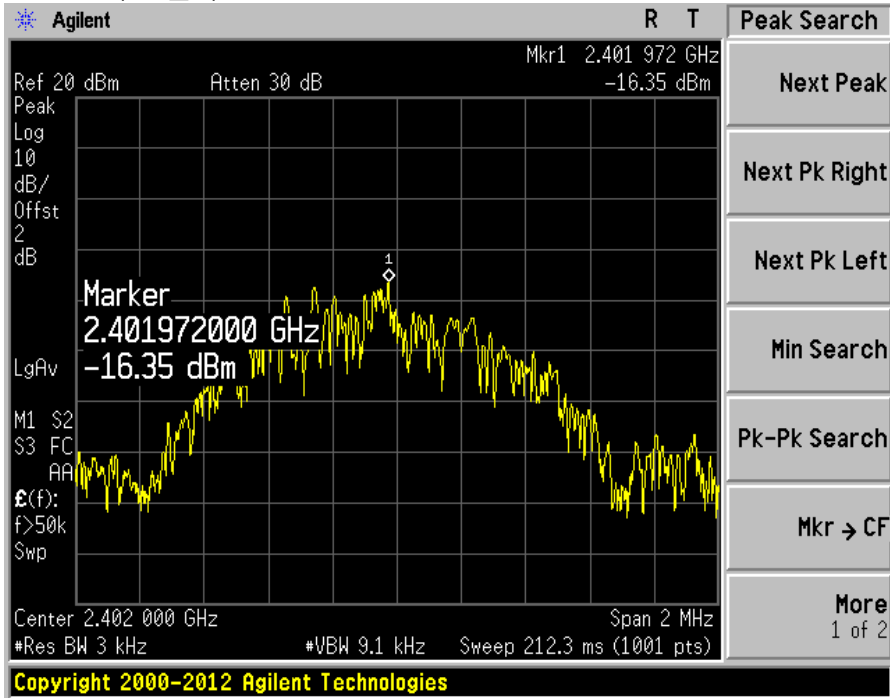

### (ch\_19)

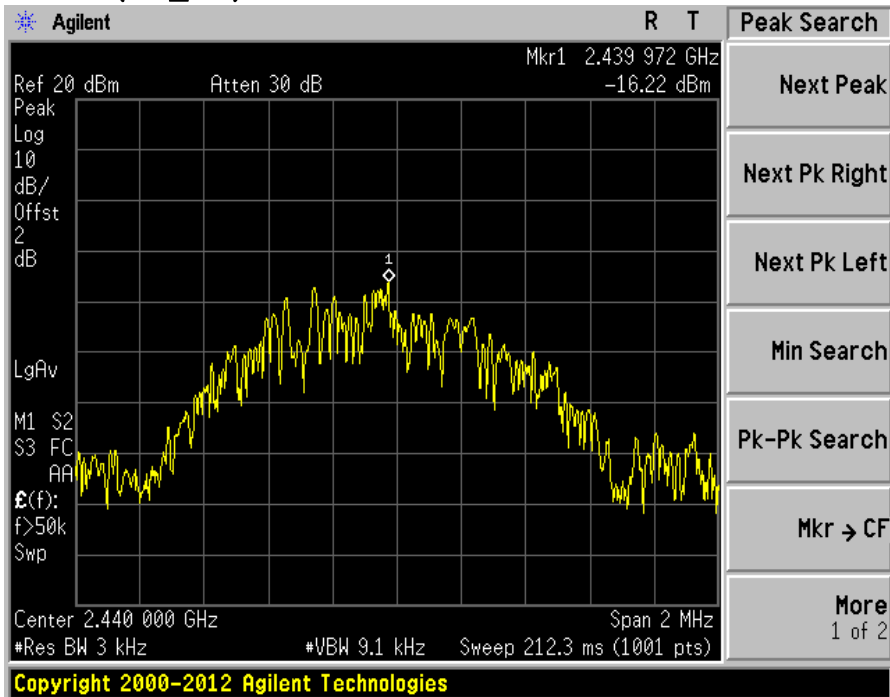



**Estech**  
your best partner

(ch\_39)

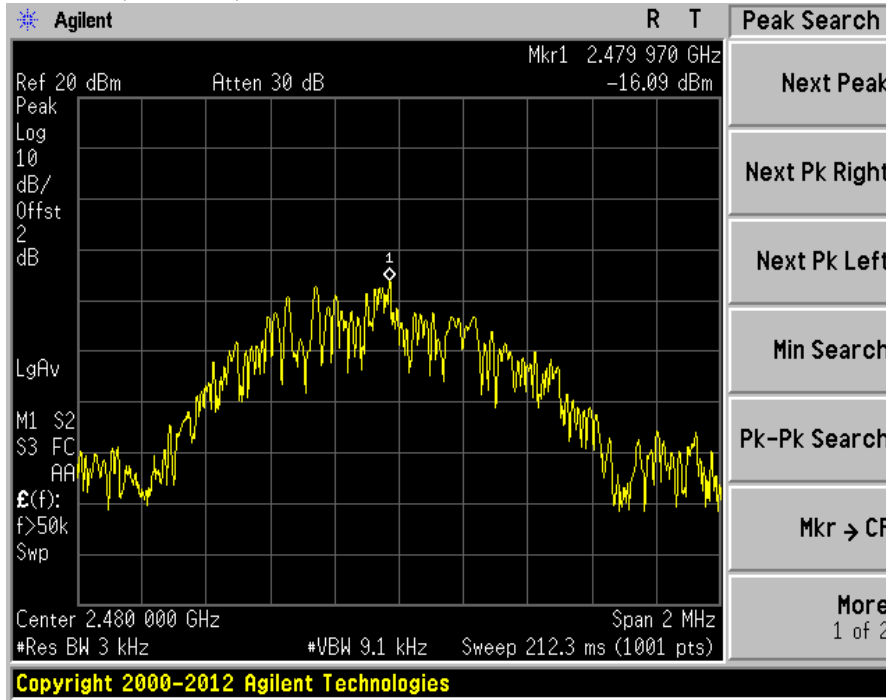



## 9. Emissions in non-restricted frequency bands

### 9.1 Test procedure

KDB 558074 D01 DTS Meas Guidance V05r02 11.0 & RSS-247 section 5.5

### 9.2 Test instruments and measurement setup

The DTS rules specify that in any 100 kHz bandwidth outside of the authorized frequency band, the power shall be attenuated according to the following conditions(15.247(d))

- a) Set the center frequency and span to encompass frequency range to be measured.
- b) Set the RBW = 100 kHz.
- c) Set the VBW  $\geq 3 \times$  RBW.
- d) Detector = peak.
- e) Sweep time = auto couple.
- f) Trace mode = max hold.
- g) Allow trace to fully stabilize.
- h) Use the peak marker function to determine the maximum amplitude level.

Limits FCC § 15.247

#### Band Edge&Out of Emission Test Instruments

Description	Model	Serial Number	Cal. Due Date
Spectrum Analyzer	E4440A	US42041291	2022-11-29
RF Cable	Length: 30 cm		-
-Spectrum Analyzer <=> EUT	Loss: 2 dB		-

### 9.3 Measurement results of band-edge & out of emission

EUT	Xpass 2	MODEL	XP2-MDPB
MODE	GFSK	ENVIRONMENTAL CONDITION	22.3 °C, 44.6 % R.H
INPUT POWER	DC 24.0 V		

CHANNEL	Channel Frequency (MHz)	limit	PASS/FAIL
0	2 402	20dBc	PASS
39	2 480	20dBc	PASS

### 9.4 Trace data of band-edge & Out of Emission (ch\_0)

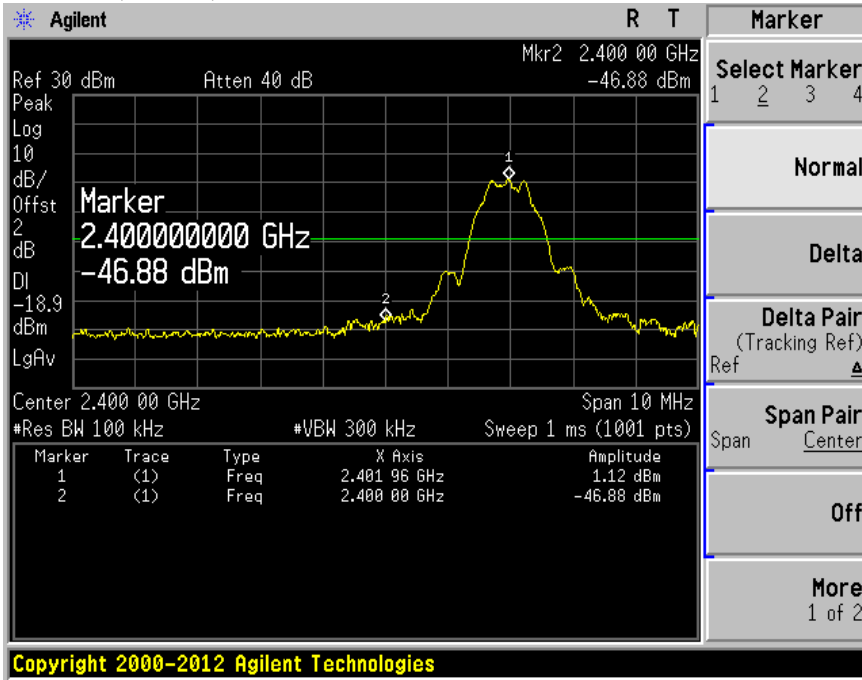

### (ch\_39)

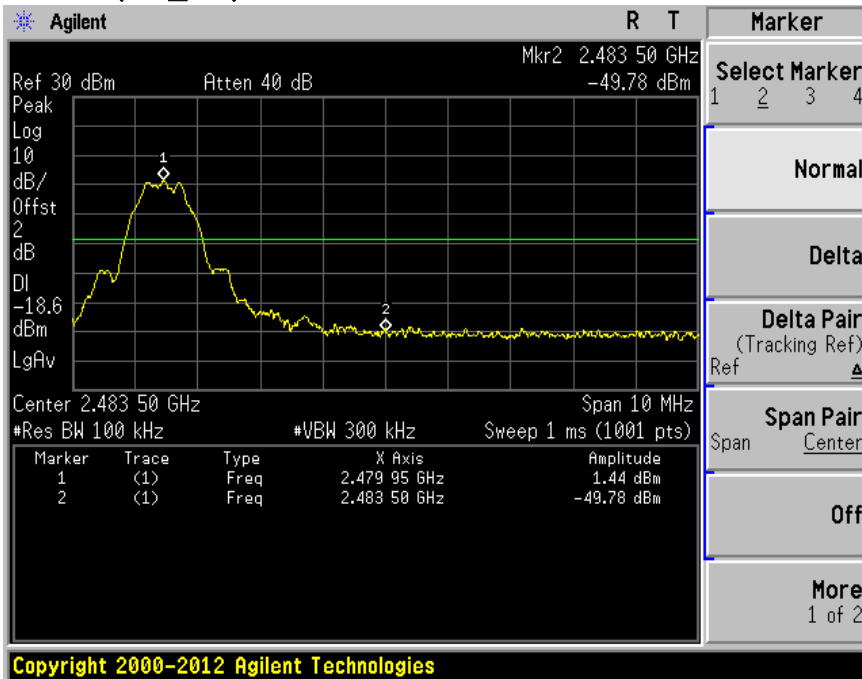



**Estech**  
your best partner

(ch\_0)

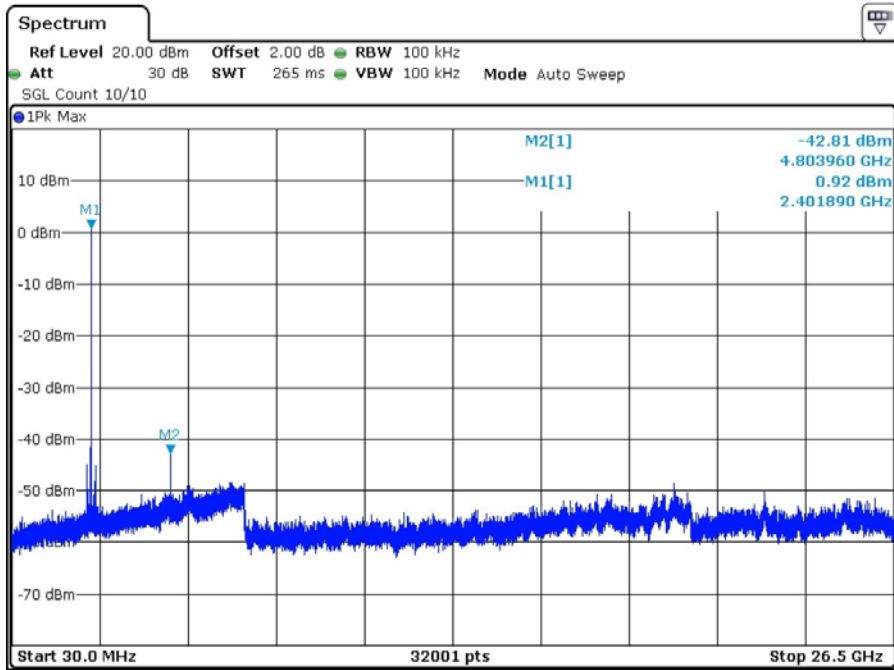

(ch\_19)

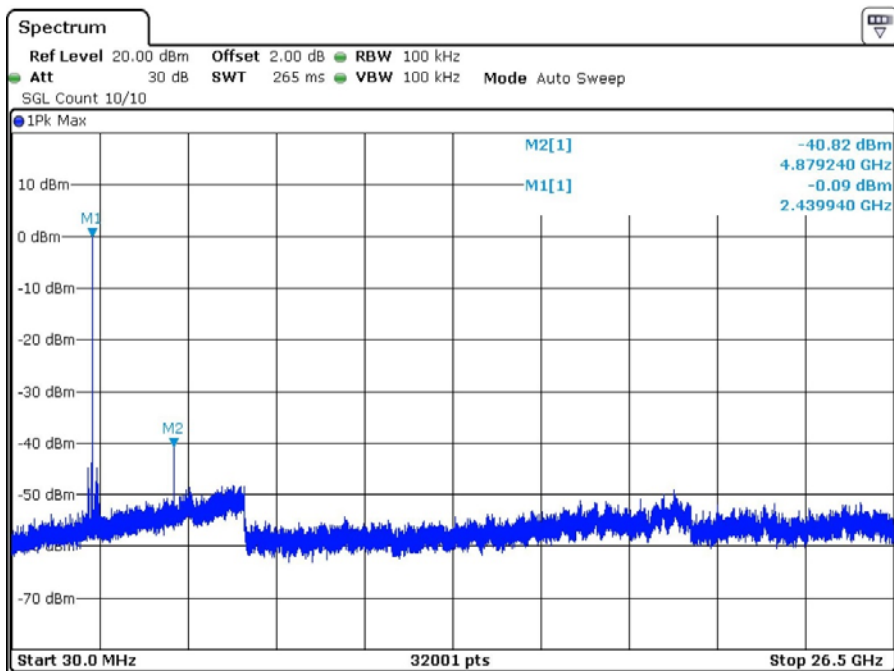



**Estech**  
your best partner

(ch\_39)

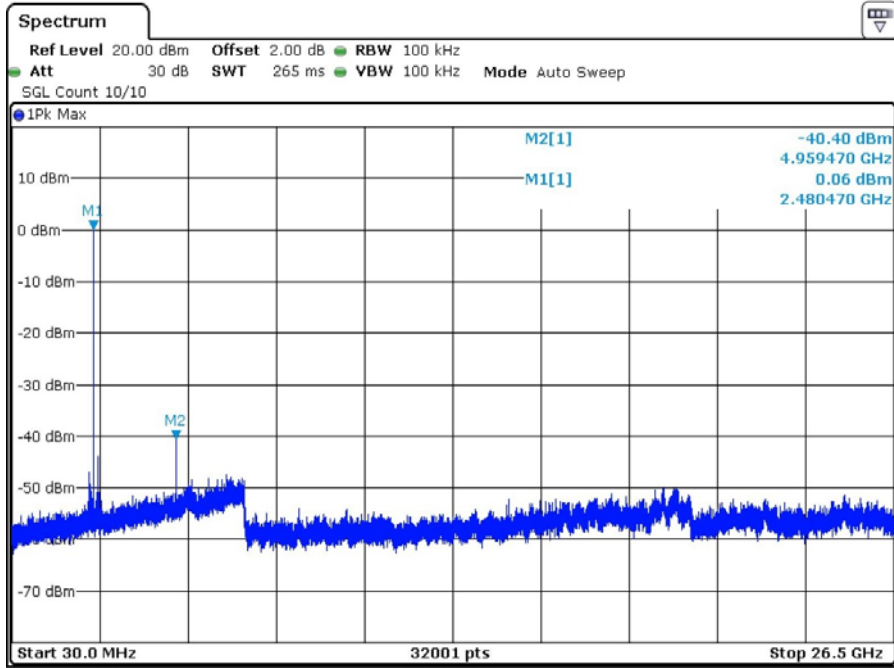

## 10. Measurement of radiated disturbance

Above 30 MHz Electric Field strength was measured in accordance with FCC PART 15.205, 15.209 . The test setup was made according to ANSI C 63.10 (2013) & KDB 558074 D01v05r02 Semi-anechoic chamber, which allows a 3 m distance measurement. The EUT was placed in the center of styrofoam. turntable. The height of this table was 0.8 m. The measurement was conducted with both horizontal and vertical antenna polarization. The turntable has fully rotated. For further description of the configuration refer to the picture of the test setup.

### 10.1 Measurement equipments

Equipment Name	Type	Manufacturer	Serial No.	Next Calibration date
TEST Receiver	ESCI7	ROHDE & SCHWARZ	100916	19-Jul-22
Logbicon Antenna	VULB 9168	SCHWARZBECK	193	9-Dec-23
Turn Table	DT3000-2t	Innco System GmbH	N/A	-
Antenna Mast	MA4000-EP	Innco System GmbH	N/A	-
PREAMPLIFIER	8449B	HP	3008A00581	20-Jul-22
Horn Antenna	BBHA9120D	SCHWARZBECK	469	3-Dec-22
TEST Receiver	ESU	ROHDE & SCHWARZ	100529	19-Jul-22
Turn Table	DT1500-S	Innco System GmbH	N/A	-
Antenna Mast	MA4000-EP	Innco System GmbH	N/A	-
Antenna Master & Turn table controller	C02000-P	Innco System GmbH	CO2000/642 /28051111/L	-

### 10.2 Environmental Condition

Below 1 GHz –Test Place : 10 m Semi-anechoic chamber

#### BT(BLE) MODE

Temperature (°C) : 21.4 °C

Humidity (% R.H.) : 43.2 % R.H.

Above 1 GHz–Test Place : 3 m Semi-anechoic chamber

#### BT(BLE) MODE

Temperature (°C) : 22.6 °C

Humidity (% R.H.) : 43.4 % R.H.

## 10.3 Measurement Instrument setting for Radiated Emission

### 10.3.1 Frequency range below 1 GHz

Detector : Quasi-Peak

### 10.3.2 Frequency range above 1 GHz

#### Peak Power Measurement Procedure (KDB 558074 section 12.2.4)

- a. RBW : 1 MHz , VBW : 3 MHz
- b. Trace mode = max hold
- c. Detector : Peak
- d. Sweep time = auto

#### Average Power Measurement Procedures (KDB 558074 section 12.2.5.2)

- a. Set analyzer center frequency to the frequency associated with the emission
- b. RBW : 1 MHz , VBW : 3 MHz
- c. Detector : RMS
- d. Sweep time = auto

Note

Band	Duty cycle(%)	Ton (ms)	Ton + Toff (ms)	DCF=10*log(1/Duty) (dB)
BT(BLE)	16.368	0.102	0.626	7.860

\* This was applied of duty cycle factor for average value because of measured with the EUT transmitting continuously less than 98 % duty cycle at its maximum power control level.



### 10.4 Test data(30 MHz ~ 1 000 MHz)

Test Date : 2-Jun-22

Measurement Distance : 3 m

Frequency (MHz)	Reading (dB $\mu$ V)	Position (V/H)	Height (m)	Correction Factor		Result Value(Quasi-peak)		
				Ant Factor (dB)	Cable (dB)	Limit (dB $\mu$ V/m)	Result (dB $\mu$ V/m)	Margin (dB)
30.10	22.35	V	1.6	12.34	0.81	40.00	35.50	4.50
88.80	24.84	V	1.5	8.73	1.40	43.50	34.97	8.53
250.00	27.70	V	1.4	11.80	2.45	46.00	41.95	4.05
400.00	20.53	V	1.3	15.63	3.16	46.00	39.32	6.68
406.80	16.67	H	1.0	15.87	3.18	46.00	35.73	10.27
433.90	16.07	H	1.0	16.55	3.28	46.00	35.90	10.10
Remark	<p>H : Horizontal, V : Vertical TEST MODE : BT BLE (CH : 19 - 2 440 MHz)</p> <p>*Checked in all 3 axis and the maximum measured data were reported.( Worst data is X axis of position)</p> <p>*CL = Cable Loss(In case of below 1 000 MHz)</p> <p>*Result Value = Reading + Ant Factor + Cable loss</p> <p>*The resolution bandwidth and video bandwidth of test receiver/spectrum analyzer is 120 kHz for Quasi-peak detection at frequency below 1 GHz.</p>							

### 10.4-1 Restricted Band Edges

Polarity:Horizontal

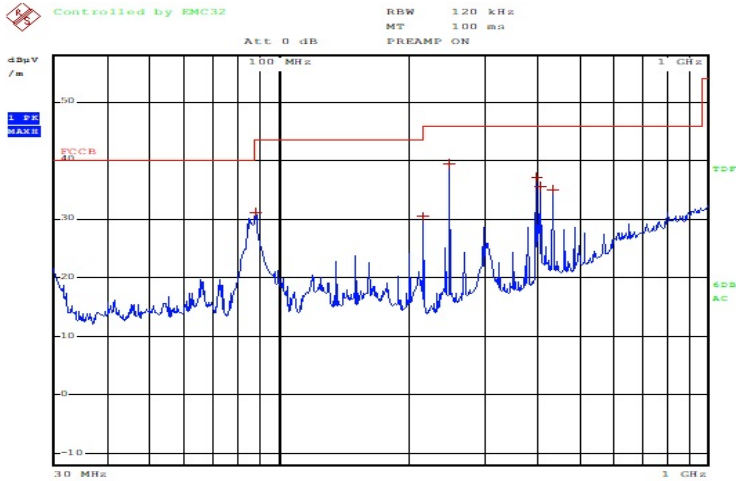

ESTR-22-00156

Polarity:Vertical

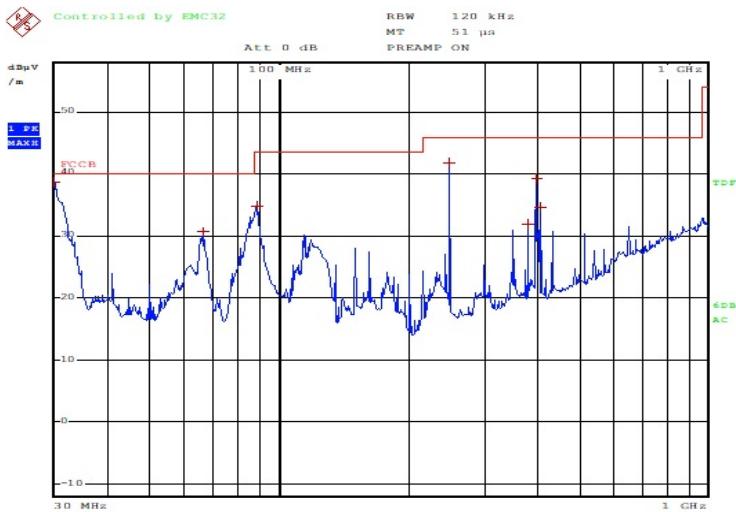

ESTR-22-00156

### 10.4-2 Test Data(Low)

Test Date : 4-Jun-22

Measurement Distance : 3 m

Frequency (MHz)	Reading (dB $\mu$ V)	Position (V/H)	Height (m)	Correction Factor		Duty Cycle Correction(dB)	Result Value		
				Ant Factor (dB)	AMP & Cable (dB)		Limit (dB $\mu$ V/m)	Result (dB $\mu$ V/m)	Margin (dB)
PEAK(RBW: 1 MHz VBW: 3 MHz)									
2388.20	52.42	H	1.6	27.55	-28.40		74.00	51.57	22.43
2388.40	52.40	V	1.6	27.55	-28.40		74.00	51.55	22.45
2390.00	45.52	H	1.6	27.54	-28.39		74.00	44.67	29.33
2390.00	45.38	V	1.6	27.54	-28.39		74.00	44.53	29.47
4804.00	45.44	H	1.5	31.30	-25.75		74.00	50.99	23.01
4804.00	45.20	V	1.5	31.30	-25.75		74.00	50.75	23.25
AV(RBW: 1 MHz VBW: 3 MHz)									
2388.20	35.07	H	1.6	27.55	-28.40	7.86	54.00	42.08	11.92
2388.20	34.62	V	1.6	27.55	-28.40	7.86	54.00	41.63	12.37
2390.00	33.91	H	1.6	27.54	-28.39	7.86	54.00	40.91	13.09
2390.00	33.91	V	1.6	27.54	-28.39	7.86	54.00	40.91	13.09
4804.00	33.87	H	1.5	31.30	-25.75	7.86	54.00	47.28	6.72
4804.00	33.85	V	1.5	31.30	-25.75	7.86	54.00	47.26	6.74
Remark	<p>H : Horizontal, V : Vertical TEST MODE : CH : 0 - 2 402 MHz (x postion)</p> <p>*The TX signal wasn't detected from 3th harmonics.</p> <p>*Checked in all 3 axis and the maximum measured data were reported.( Worst data is X axis of position)</p> <p>*Total = Reading Value + Antenna Factor + Cable Loss - Amp Gain + Duty Cycle Correction</p> <p>*This test was radiated up to 26.5 GHz but no noise was measured.</p>								



### 10.4-3 Test Data(Middle)

Test Date : 4-Jun-22

Measurement Distance : 3 m

Frequency (MHz)	Reading (dB $\mu$ V)	Position (V/H)	Height (m)	Correction Factor		Duty Cycle Correction(dB)	Result Value		
				Ant Factor (dB)	AMP & Cable (dB)		Limit (dB $\mu$ V/m)	Result (dB $\mu$ V/m)	Margin (dB)
PEAK(RBW: 1 MHz VBW: 3 MHz)									
4880.00	46.12	H	1.5	31.30	-25.67	/	74.00	51.75	22.25
4880.00	45.55	V	1.6	31.30	-25.67		74.00	51.18	22.82
AV(RBW: 1 MHz VBW: 3 MHz)									
4880.00	34.82	H	1.5	31.30	-25.67	7.86	54.00	48.31	5.69
4880.00	34.05	V	1.6	31.30	-25.67	7.86	54.00	47.54	6.46
Remark	H : Horizontal, V : Vertical TEST MODE : CH : 19 - 2 440 MHz (x postion)  *The TX signal wasn't detected from 3th harmonics. *Checked in all 3 axis and the maximum measured data were reported.( Worst data is X axis of position) *Total = Reading Value + Antenna Factor + Cable Loss - Amp Gain + Duty Cycle Correction *This test was radiated up to 26.5 GHz but no noise was measured.								

### 10.4-4 Test Data(High)

Test Date : 5-Jun-22

Measurement Distance : 3 m

Frequency (MHz)	Reading (dB $\mu$ V)	Position (V/H)	Height (m)	Correction Factor		Duty Cycle Correction (dB)	Result Value		
				Ant Factor (dB)	AMP & Cable (dB)		Limit (dB $\mu$ V/m)	Result (dB $\mu$ V/m)	Margin (dB)
PEAK(RBW: 1 MHz VBW: 3 MHz)									
2483.50	59.21	H	1.6	27.42	-28.28	/	74.00	58.35	15.65
2483.50	58.18	V	1.8	27.42	-28.28	/	74.00	57.32	16.68
2493.29	52.93	H	1.6	27.41	-28.27	/	74.00	52.07	21.93
2493.29	51.39	V	1.5	27.41	-28.27	/	74.00	50.53	23.47
4960.00	47.91	H	1.6	31.48	-25.59	/	74.00	53.80	20.20
4960.00	47.26	V	1.5	31.48	-25.59	/	74.00	53.15	20.85
AV(RBW: 1 MHz VBW: 3 MHz)									
2483.50	35.75	H	1.6	27.42	-28.28	7.86	54.00	42.74	11.26
2483.50	35.90	V	1.8	27.42	-28.28	7.86	54.00	42.89	11.11
2493.29	34.73	H	1.6	27.41	-28.27	7.86	54.00	41.73	12.27
2493.29	34.54	V	1.5	27.41	-28.27	7.86	54.00	41.54	12.46
4960.00	33.57	H	1.6	31.48	-25.59	7.86	54.00	47.32	6.68
4960.00	33.40	V	1.5	31.48	-25.59	7.86	54.00	47.15	6.85
Remark	<p>H : Horizontal, V : Vertical TEST MODE : CH : 39 - 2 480 MHz (x postion)</p> <p>*The TX signal wasn't detected from 3th harmonics.            *Checked in all 3 axis and the maximum measured data were reported.( Worst data is X axis of position)            *Total = Reading Value + Antenna Factor + Cable Loss - Amp Gain + Duty Cycle Correction            *This test was radiated up to 26.5 GHz but no noise was measured.</p>								

## 10.4-5 Restricted Band Edges

Band Edges(CH Low)

Detector mode:Peak

Polarity:Horizontal

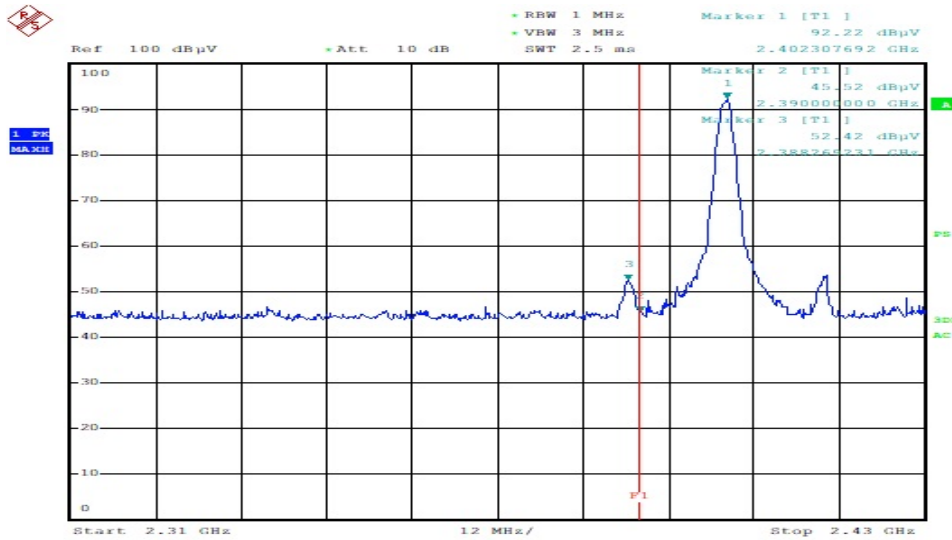

ESTR-22-00156,00159

Detector mode:Average

Polarity:Horizontal

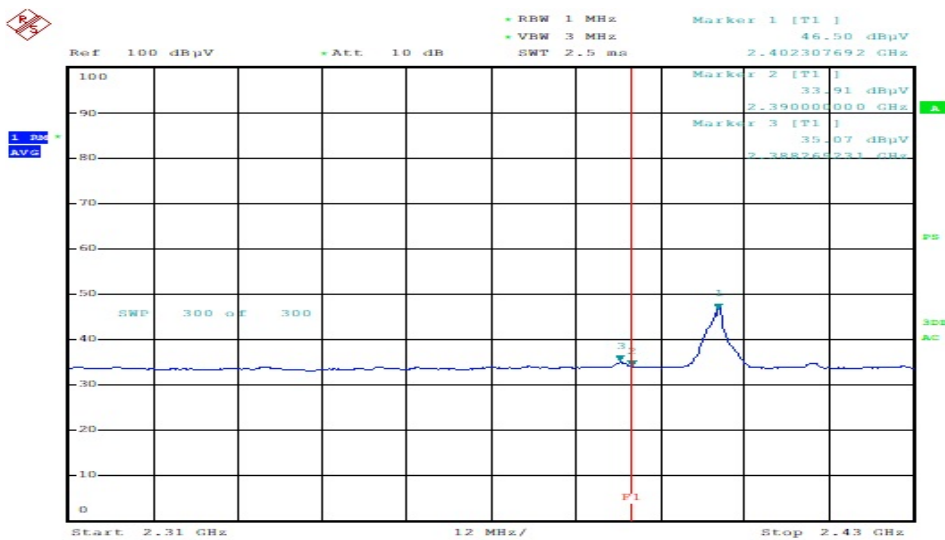

ESTR-22-00156,00159

Band Edges(CH Low)

Detector mode:Peak

Polarity:Vertical

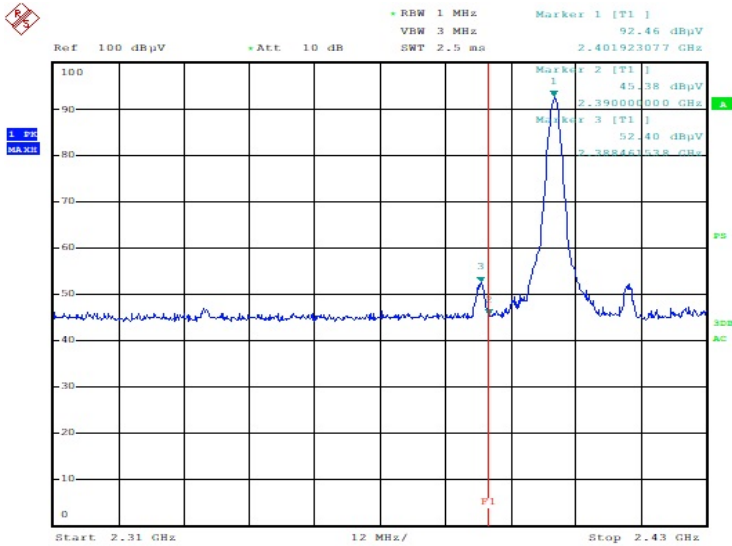

ESTR-22-00156,00159

Detector mode:Average

Polarity:Vertical

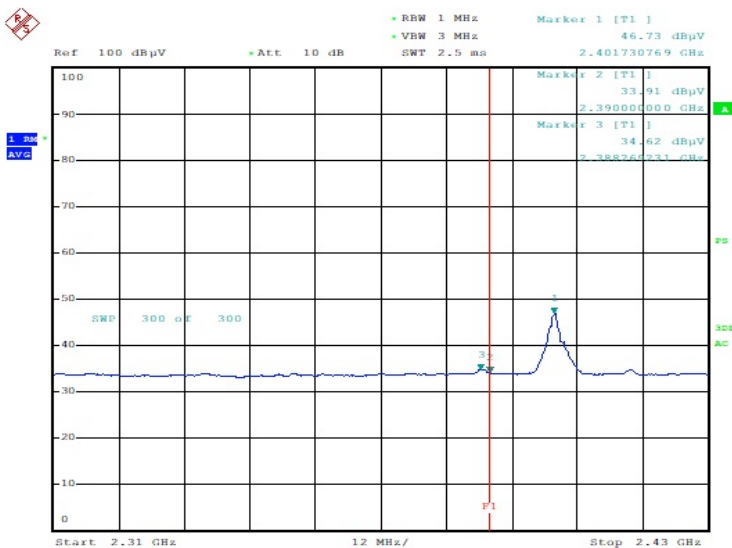

ESTR-22-00156,00159

Band Edges(CH High)

Detector mode:Peak

Polarity:Horizontal

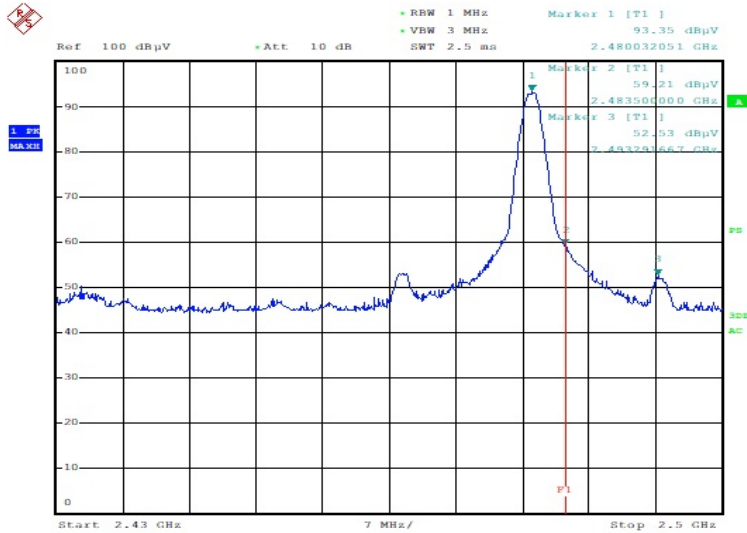

ESTR-22-00156,00159

Detector mode:Average

Polarity:Horizontal

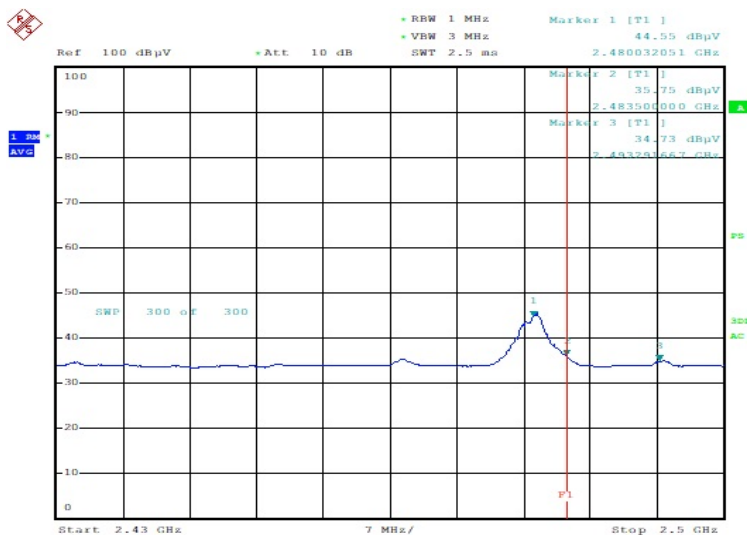

ESTR-22-00156,00159



Band Edges(CH High)

Detector mode:Peak

Polarity:Vertical

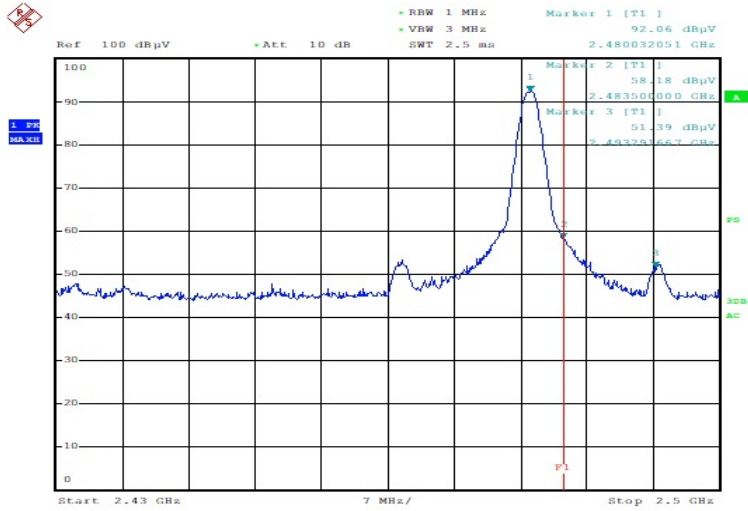

ESTR-22-00156,00159

Detector mode:Average

Polarity:Vertical

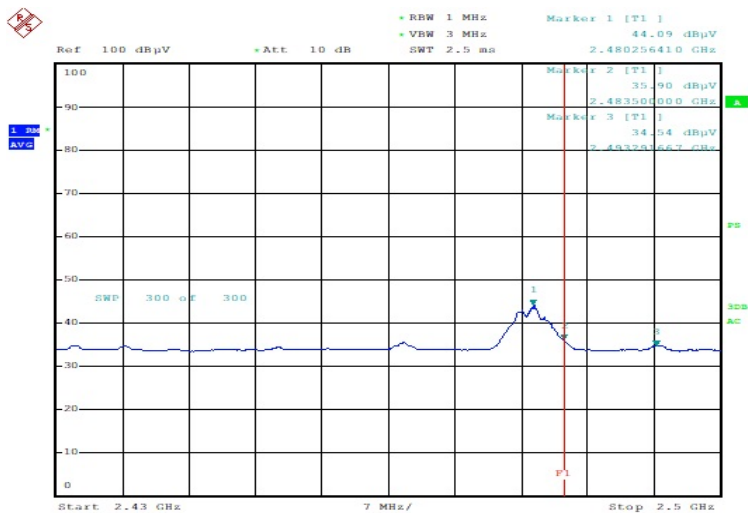

ESTR-22-00156,00159

# 10.4-6 Restricted Band Edges

Band Edges(CH Low)

Polarity:Horizontal

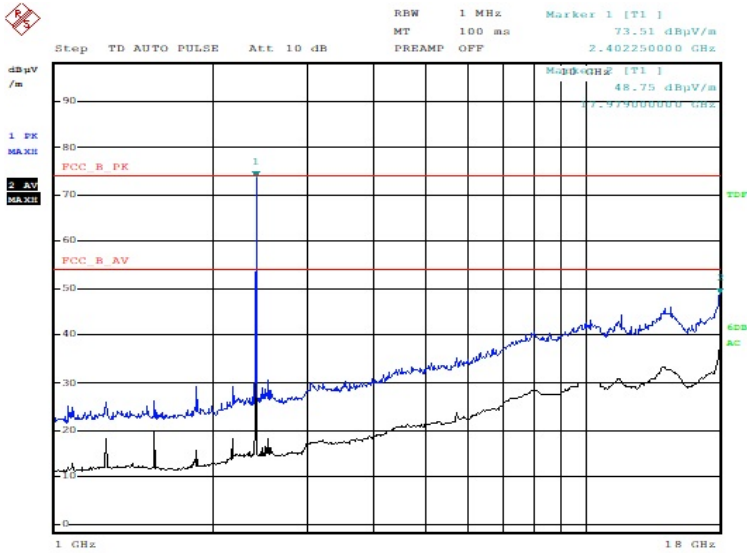

ESTE-19-02241-HOR

Polarity:Vertical

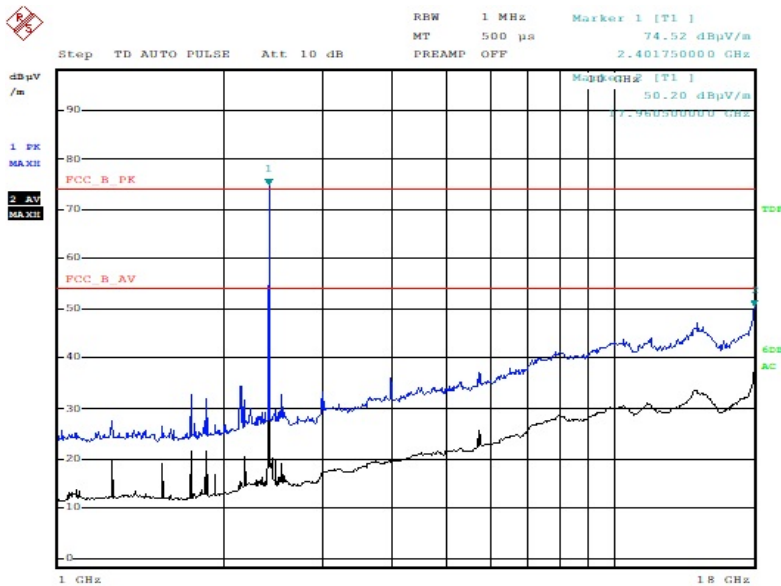

ESTE-19-02241-HOR

Band Edges(CH Middle)

Polarity:Horizontal

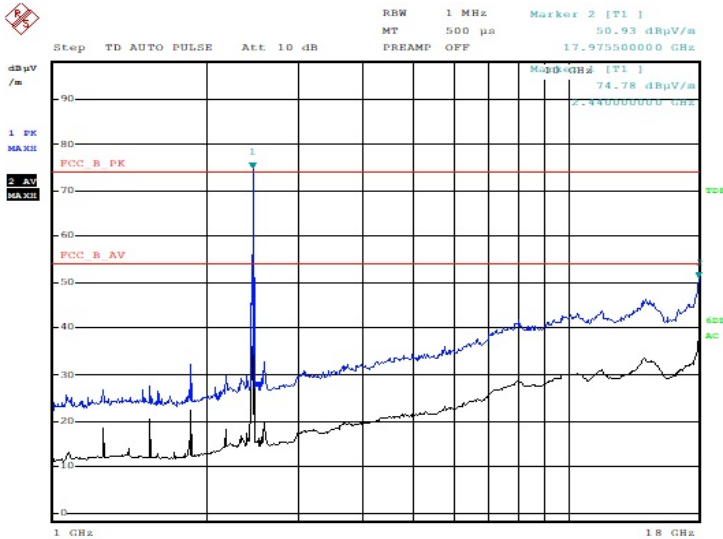

ESTE-19-02241-HOR

Polarity:Vertical

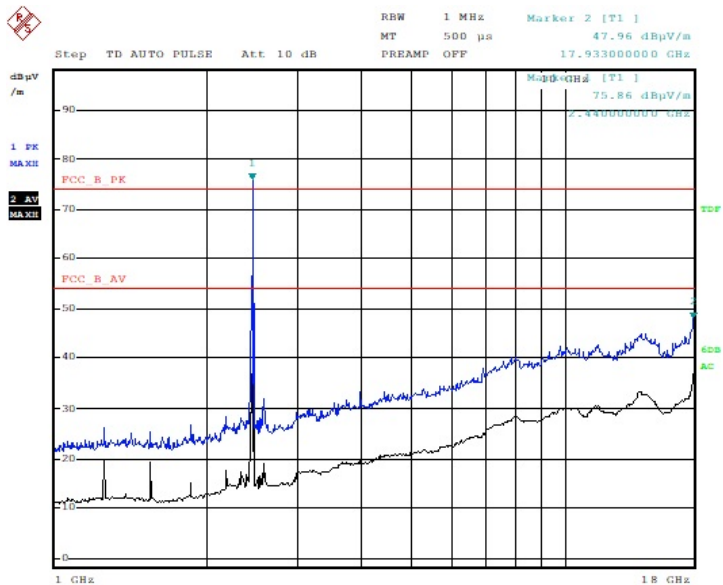

ESTE-19-02241-HOR

Band Edges(CH High)

Polarity:Horizontal

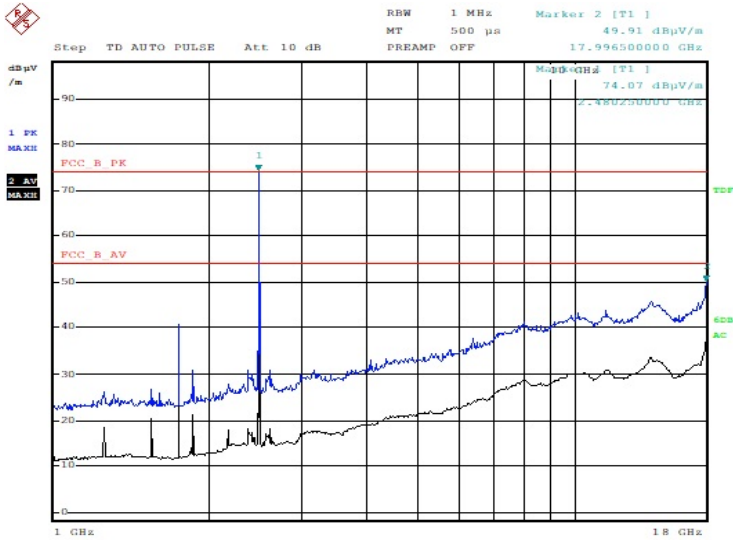

ESTE-19-02241-HOR

Polarity:Vertical

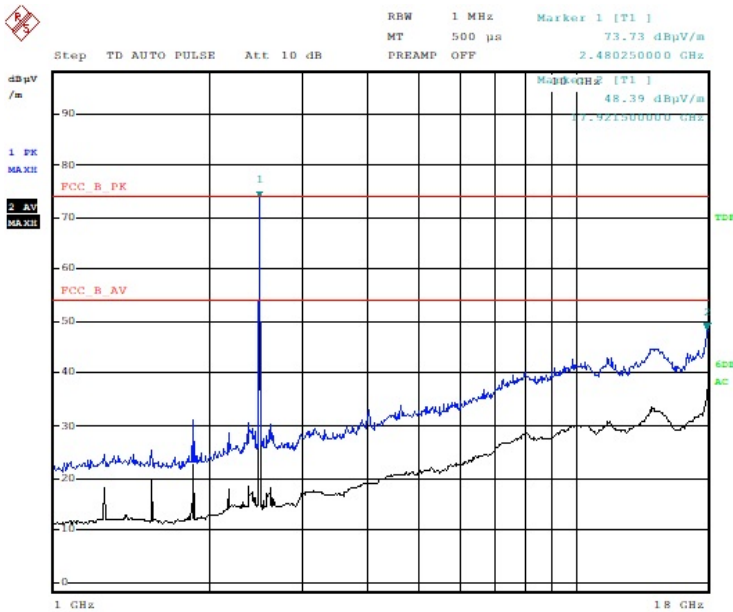

ESTE-19-02241-HOR

## 11. Measurement of conducted disturbance

The continuous disturbance voltage of AC Mains in the frequency from 0.15 MHz to 30 MHz was measured in accordance to FCC PART 15.207. The test setup was made according to ANSI C 63.10 (2009) in a shielded room. The EUT was placed on a non-conductive table at least 0.8 m above the ground plan. A grounded vertical reference plane was positioned in a distance of 0.4 m from the EUT. The distance from the EUT to other metal surfaces was at least 0.8 m. The EUT was only earthen by its power cord through the line impedance stabilizing network. The power cord has been bundled to a length of 1.0 m. The test receiver with Quasi Peak detector complies with CISPR 16.

### 11.1 Measurement equipments

Equipment Name	Type	Manufacturer	Serial No.	Next Calibration date
TEST RECEIVER	ESPI	Rohde & Schwarz	100005	19-Jul-22
LISN	ESH3-Z5	Rohde & Schwarz	836679/025	19-Jul-22
Pulse Limiter	ESH3Z2	Rohde & Schwarz	NONE	19-Jul-22

### 11.2 Environmental Condition

Test Place : Shielded Room

Temperature (°C) : 23.4 °C

Humidity (% R.H.) : 43.6 % R.H.

### 11.3 Test Data

Test Date : 6-Jun-22

Frequency (MHz)	Correction Factor		Line (H/N)	Quasi-peak Value			Average Value		
	Lisn (dB)	Cable (dB)		Limit (dB $\mu$ V)	Reading (dB $\mu$ V)	Result (dB $\mu$ V)	Limit (dB $\mu$ V)	Reading (dB $\mu$ V)	Result (dB)
0.15	0.05	0.18	N	64.04	38.54	36.22	54.04	29.01	29.99
0.19	0.04	0.20	N	62.10	38.89	41.82	52.10	24.86	32.56
0.20	0.04	0.31	N	56.69	38.14	46.63	46.69	24.74	38.09
0.46	0.04	0.32	H	56.51	32.26	48.89	46.51	17.80	41.15
14.85	0.04	0.34	N	56.00	33.71	33.23	46.00	24.65	28.45
16.54	0.04	0.47	N	56.00	30.52	37.20	46.00	23.35	30.77
Remark	H : Hot Line, N : Neutral Line *Correction Factor = Lisn + Cable *Result = Correction Factor + Reading								

# Appendix 1. Special diagram

## \* CONDUCTED EMISSION

### \* HOT LINE

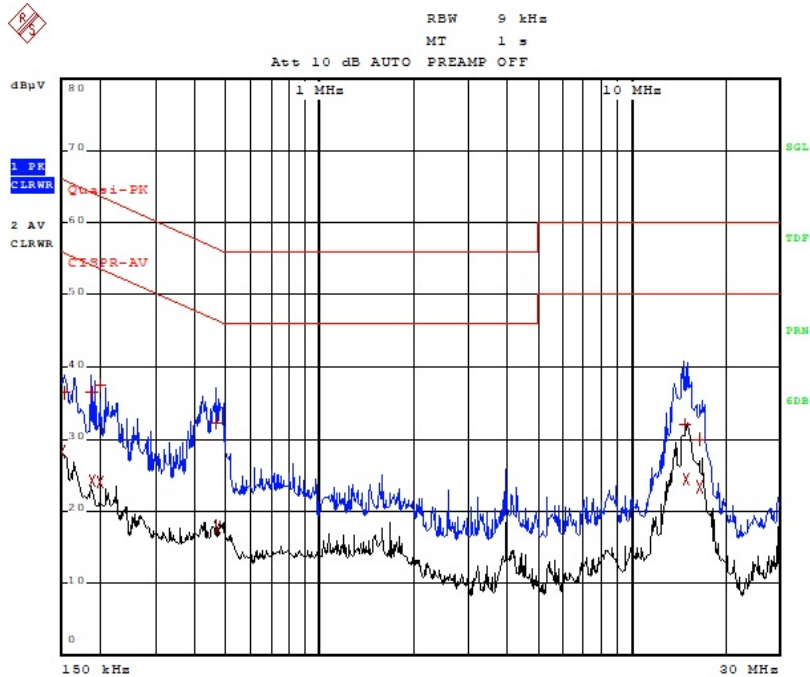

Comment: ESTR-22-00156\_BLE\_HOT

### \* NEUTRAL LINE

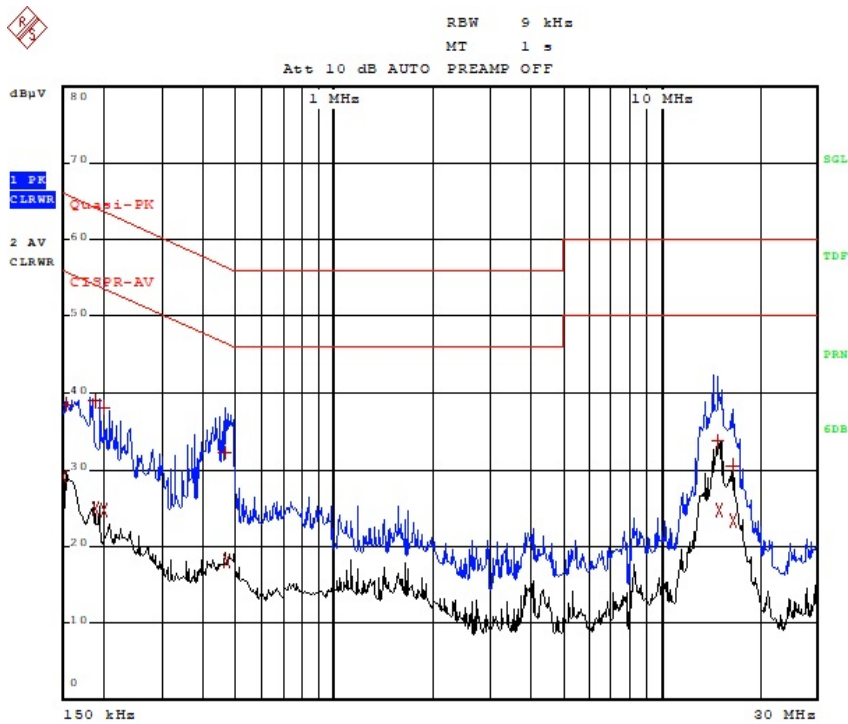

Comment: ESTR-22-00156\_BLE\_NEUTRAL

## Appendix 2. Antenna information

### 1. Antenna information

antenna type : Intergrated FPCB Antenna.

antenna location : Integnal

antenna gain : 0.9 dBi

No temporary RF connector provided