

Test Report for FCC

Report Number		ESTRGC2402-003		
Applicant	Company name	Suprema Inc		
	Address	17F-5, Parkview office tower, 248, Jeongjail-ro Bundang-gu, Seongnam-si, Gyeonggi-do South Korea		
	Telephone	+82-031-240-4333		
Product	Product name	Xpass 2		
	Model No.	XP2-MAPB	Manufacturer	Suprema Inc
	Serial No.	NONE	Country of origin	KOREA
Test date	12-Feb-24 ~ 22-Feb-24		Date of issue	27-Feb-24
Testing location	140-16, Eongmali-ro, Majang-myeon, Icheon-si, Gyeonggi-do, Rep. of Korea			
FCC ID	TKWXP2-MAPB			
FCC Rule Part(s)	Part 15.225, Part 15.209, Part 15.207			
Test result				Complied
Measurement facility registration number		659627		
MRA Registration number		KR0019		
Tested by	Engineer H.G. Lee		(Signature)	
Reviewed by	Engineering Manager I.K. Hong		(Signature)	
Abbreviation	OK, Pass = Complied, Fail = Failed, N/A = not applicable			
<p>* Note</p> <ul style="list-style-type: none"> - This test report is not permitted to copy partly without our permission - This test result is dependent on only equipment to be used - This test report is not related to KOLAS accreditation 				

Contents

1. Laboratory Information	3
2. Description of EUT	4
3. Test Standards	5
4. Measurement Condition	8
5. 20dB Bandwidth / 99% Bandwidth	10
6. Frequency Tolerance	12
7. Measurement of radiated disturbance	13
8. Measurement of conducted disturbance	17

1. Laboratory Information

1.1 General

This EUT (Equipment Under Test) has been shown to be capable of compliance with the applicable technical standards and is tested in accordance with the measurement procedures as indicated in this report. ESTECH Lab attests to accuracy of test data. All measurement reported herein were performed by ESTECH Co., Ltd. ESTECH Lab assume full responsibility for the completeness of these measurements and vouch for the qualifications of all persons taking them.

1.2 Test Lab.

Corporation Name : ESTECH Co., Ltd.

Head Office : Suite 1015 World Meridian II, 123 Gasan Digital 2-ro, Geumcheon-gu,
Seoul 153-759, R. O. Korea

EMC/Telecom/Safety Test Lab : 140-16, Eongmalli-ro, Majang-myeon, Icheon-si,
Gyeonggi-do, Rep. of Korea

1.3 Official Qualification(s)

MSIP : Granted Accreditation from Ministry of Information & Communication for EMC, Safety
and Telecommunication

KOLAS : Accredited Lab By Korea Laboratory Accreditation Schema base on CENELEC

FCC : Filed Laboratory at Federal Communications Commission

VCCI : Granted Accreditation from Voluntary Control Council for Interference from ITE

ISED : Accredited Lab By Canada Laboratory Accreditation

2. Description of EUT

2.1 Summary of Equipment Under Test

Product : Xpass 2
 Model Number : XP2-MAPB
 Serial Number : NONE
 Manufacturer : Suprema Inc
 Transfer Rate : 130.4 kHz, 13.56 MHz
 Power Rating : INPUT: AC(100 - 240) V, (50-60)Hz, 1.7 A
 OUTPUT: DC 12V,DC 24 V, 2.5 A, POE
 Receipt Date : 29-Jan-24

X-tal list(s) or Frequencies generated : 13.56 MHz

Software version:V1.0.0
 Hardware version:V1.0.0

2.2 General descriptions of EUT

Category	Feature	Specifications
Credential	RF Option	<ul style="list-style-type: none"> • XP2-MDPB, XP2-GDPB, XP2-GKDPB: 125 kHz EM & 13.56 MHz MIFARE, MIFARE Plus, DESFire, DESFire EV1/EV2/EV3[®], FeliCa • XP2-MAPB: 125 kHz EM, HID Prox & 13.56 MHz MIFARE, MIFARE Plus, DESFire, DESFire EV1/EV2/EV3[®], FeliCa, iCLASS SE/SR/Seos
	RF Read Range [®]	<ul style="list-style-type: none"> • XP2-MDPB, XP2-GDPB, XP2-GKDPB: MIFARE/DESFire/EM: 50 mm, FeliCa: 30 mm • XP2-MAPB: MIFARE/DESFire/iCLASS/EM: 50 mm, HID Prox/FeliCa: 30 mm
General	Mobile	NFC, BLE
	CPU	1 GHz
	Memory	4 GB Flash + 64 MB RAM
	Crypto Chip	Supported
	LED	Multi-color
	Sound	Multi-tone Buzzer
	Operating Temperature	-35 °C to 65 °C
	Storage Temperature	-40 °C to 70 °C
	Operating Humidity	0 % to 95 %, non-condensing
	Storage Humidity	0 % to 95 %, non-condensing
	Dimension (W x H x D)	<ul style="list-style-type: none"> • XP2-MDPB, XP2-MAPB: 48 x 144.7 x 27 (mm) • XP2-GDPB: 80 x 130 x 25 (mm) • XP2-GKDPB: 80 x 130 x 25 (mm)
	Weight	<ul style="list-style-type: none"> • Device <ul style="list-style-type: none"> – XP2-MDPB, XP2-MAPB: 144 g – XP2-GDPB: 220 g – XP2-GKDPB: 235 g • Bracket <ul style="list-style-type: none"> – XP2-MDPB, XP2-MAPB: 30 g (Including washer and bolt) – XP2-GDPB: 52 g (Including washer and bolt) – XP2-GKDPB: 52 g (Including washer and bolt)
	IP Rating	IP65, IP67
	IK Rating	IK08
	Certificates	<ul style="list-style-type: none"> • XP2-MDPB, XP2-GDPB: CE, UKCA, KC, FCC, IC, RCM, BIS, SIG, RoHS, REACH, WEEE • XP2-GKDPB: CE, UKCA, KC, FCC, IC, RCM, BIS, SIG, TELEC, RoHS, REACH, WEEE • XP2-MAPB: CE, UKCA, KC, FCC, RCM, SIG, RoHS, REACH, WEEE
Capacity	Max. User	200,000
	Max. Card	200,000
	Max. Text Log	1,000,000

3. Test Standards

Test Standard : FCC PART 15

This Standard sets out the regulations under which an intentional, unintentional, or incidental radiator may be operated without an individual license. It also contains the technical specifications, administrative requirements and other conditions relating to the marketing of Part 15 devices.

Test Method : ANSI C 63.10 (2013)

This standard sets forth uniform methods of measurement of radio-frequency (RF) signals and noise emitted from both unintentional and intentional emitters of RF energy in the frequency range 9 kHz to 40 GHz. Methods for the measurement of radiated and AC power-line conducted radio noise are covered and may be applied to any such equipment unless otherwise specified by individual equipment requirements. These methods cover measurement of certain devices that deliberately radiate energy, such as intentional emitters, but does not cover licensed transmitters. This standard is not intended for certification/approval of avionic equipment or for industrial, scientific, and medical (ISM) equipment. These methods apply to the measurement of individual units or systems comprised of multiple units

Test Description	FCC Part Section(s)	Test Limit	Test Condition	Test Result
Occupied Bandwidth	-	N/A	Radiated	PASS
20 dB Bandwidth	§15.215 (c)	N/A		PASS
Radiated E-Field Emissions 13.553 MHz - 13.567 MHz	§15.225 (a)	cf. Section 7.3		N/A 1)
Radiated E-Field Emissions 13.410 MHz ≤ f ≤ 13.553 MHz 13.567 MHz ≤ f ≤ 13.710 MHz	§15.225 (b)	cf. Section 7.3		N/A 1)
Radiated E-Field Emissions 13.110 MHz ≤ f ≤ 13.410 MHz 13.710 MHz ≤ f ≤ 14.010 MHz	§15.225 (c)	cf. Section 7.3		N/A 1)
Radiated Spurious Emissions	15.209	cf. Section 7.3		PASS
Frequency Stability	§15.225 (e)	cf. Section 7.2		PASS
AC Power line Conducted Emissions	§15.207	cf. Section 7.4	Conducted	PASS

Notes:

1. No tests were applied because the fundamental level did not exceed the spurious limit per part 15.209.

**Test Configuration
Below 30 MHz**

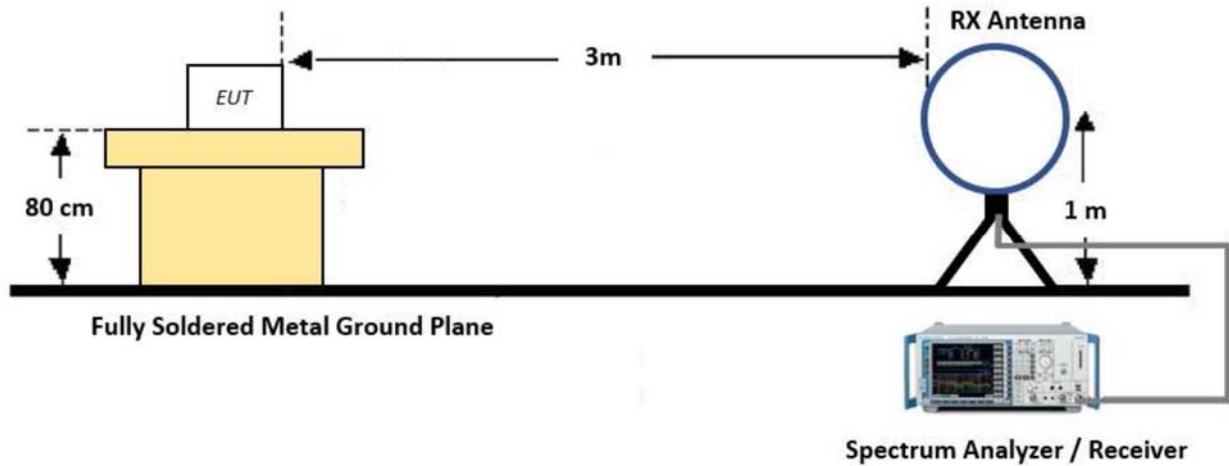

Test Procedure of Radiated spurious emissions (Below 30 MHz)

1. The EUT was placed on a non-conductive table located on semi-anechoic chamber.
2. The loop antenna was placed at a location 3m from the EUT
3. The EUT is placed on a turntable, which is 0.8m above ground plane.
4. We have done x, y, z planes in EUT and horizontal and vertical polarization in detecting antenna.
5. The turntable shall be rotated for 360 degrees to determine the position of maximum emission level.
6. Distance Correction Factor (0.009 MHz – 0.490 MHz) = $40 \cdot \log(3 \text{ m}/300 \text{ m}) = - 80 \text{ dB}$
Measurement Distance: 3 m
7. Distance Correction Factor (0.490 MHz – 30 MHz) = $40 \cdot \log(3 \text{ m}/30 \text{ m}) = - 40 \text{ dB}$
Measurement Distance: 3 m
8. Spectrum Setting
 - Frequency Range = 9 kHz ~ 30 MHz
 - Detector = Peak
 - Trace = Max hold
 - RBW = 9 kHz
 - VBW $\geq 3 \cdot$ RBW
9. Total = Reading Value + Antenna Factor (A.F) + Cable Loss (C.L) + Distance Factor (D.F)
Adequate comparison measurements were confirmed against an open field site since the test was performed at alternative site (3m SAC) other than the open area test site. Sufficient test was made to demonstrate that the alternative site produces result that correlate with the one of test made at the open field site based on KDB 414788.

30 MHz - 1 GHz

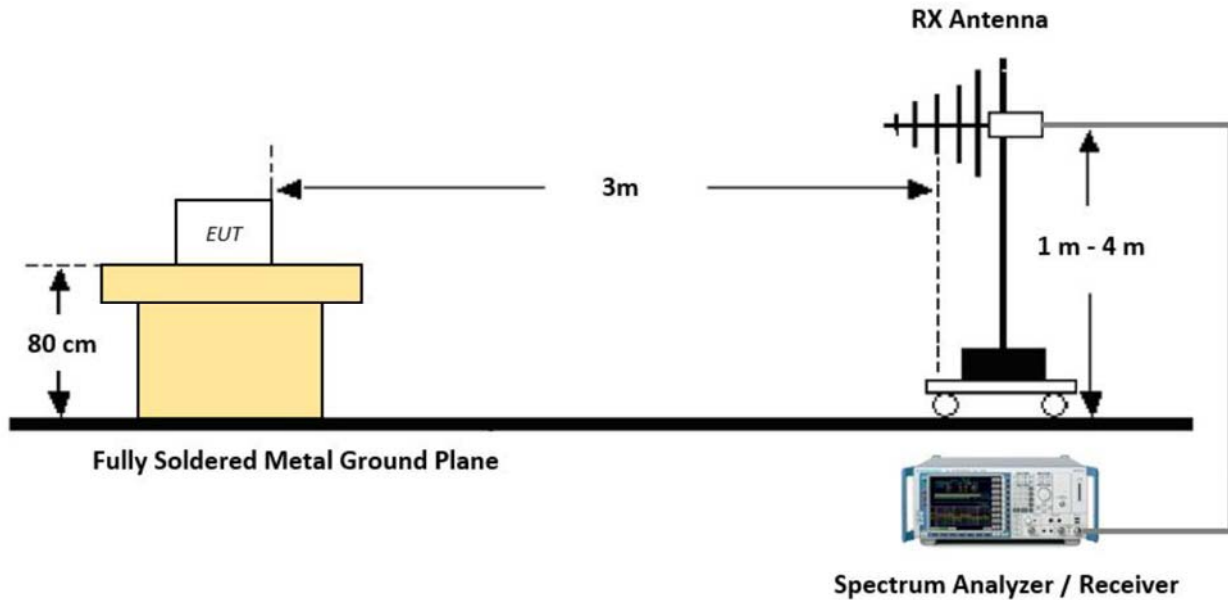

Test Procedure of Radiated spurious emissions (Below 1GHz)

1. The EUT was placed on a non-conductive table located on semi-anechoic chamber.
2. The EUT is placed on a turntable, which is 0.8m above ground plane.
3. We have done x, y, z planes in EUT and horizontal and vertical polarization in detecting antenna.
4. The turntable shall be rotated for 360 degrees to determine the position of maximum emission level.
5. Spectrum Setting
 - (1) Measurement Type (Peak):
 - Measured Frequency Range: 30 MHz – 1 GHz
 - Detector = Peak
 - Trace = Max hold
 - RBW = 100 kHz
 - VBW $\geq 3 \times$ RBW
 - (2) Measurement Type(Quasi-peak):
 - Measured Frequency Range: 30 MHz – 1 GHz
 - Detector = Quasi-Peak
 - RBW = 120 kHz
6. Total = Reading Value + Antenna Factor (A.F) + Cable Loss (C.L)

4. Measurement Condition

4.1 EUT Operation.

The EUT was tested, under transmission / receiving

1. Normal communication with RF OUT Frequency 13.56 MHz(HF), 130.4 kHz(LF).
2. Monitoring the operation status of frequency by using RF CARD.

4.2 Configuration and Peripherals

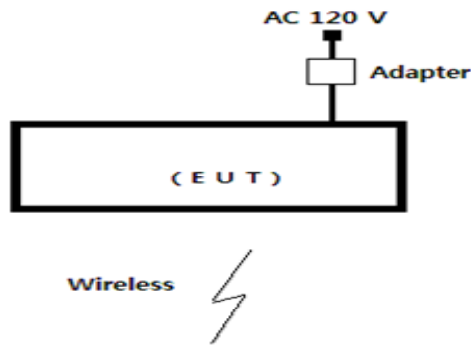

4.3 EUT and Support equipment

Equipment Name	Model Name	S/N	Manufacturer	Remark
Xpass 2	XP2-MAPB	NONE	Suprema Inc	EUT
Adapter	KPL-060M-VI	NONE	Channel Well technology (Guangzhou)Co.,Ltd.	

4.4 Measurement equipments (Conducted)

Description	Model	Serial Number	Cal. Date	Cal. Due Date
Spectrum Analyzer	E440A	US42041291	27-Nov-23	27-Nov-24
Spectrum Analyzer	FSV40	100939	27-Nov-23	27-Nov-24
RF Cable	Length: 100 cm	-		

4.5 Measurement equipments (Radiated)

Equipment Name	Type	Manufacturer	Serial No.	Cal. Date	Cal. Due Date
TEST Receiver	ESC17	ROHDE & SCHWARZ	100916	12-Jun-23	12-Jun-24
LOOP Antenna	HFH2-Z2	ROHDE & SCHWARZ	100188	29-Aug-22	29-Aug-24
Logbicon Antenna	VULB 9168	SCHWARZBECK	193	25-Oct-23	25-Oct-25
Turn Table	DT3000-2t	Innco System GmbH	N/A	-	-
Antenna Mast	MA4000-EP	Innco System GmbH	N/A	-	-
PREAMPLIFIER	8449B	HP	3008A00581	12-Jun-23	12-Jun-24
Horn Antenna	BBHA 9170	SCHWARZBECK	751	15-Jun-23	15-Jun-24
Horn Antenna	BBHA9120D	SCHWARZBECK	469	26-Oct-23	26-Oct-24
TEST Receiver	ESU	ROHDE & SCHWARZ	100529	12-Jun-23	12-Jun-24
Turn Table	DT1500-S	Innco System GmbH	N/A	-	-
Antenna Mast	MA4000-EP	Innco System GmbH	N/A	-	-
Antenna Master & Turn table controller	CO2000-P	Innco System GmbH	CO2000/642 /28051111/L	-	-

4.6 AC Power line Conducted Emissions Measurement equipments

Equipment Name	Type	Manufacturer	Serial No.	Cal. Date	Cal. Due Date
TEST Receiver	ESHS 30	Rohde & Schwarz	828765/002	28-Jun-23	28-Jun-24
LISN	ESH2-Z5	Rohde & Schwarz	836679/025	28-Jun-23	28-Jun-24
Pulse Limiter	ESH3-Z2	Rohde & Schwarz	NONE	28-Jun-23	28-Jun-24

5. 20dB Bandwidth / 99% Bandwidth

5.1 Test settings

The transmitter shall be operated at its maximum carrier power measured under normal test conditions.

- The span of the analyzer shall be set to capture all products of the modulation process, including the emission skirts.
- The resolution bandwidth (RBW) shall be in the range of 1% to 5% of the occupied bandwidth (OBW) and video bandwidth (VBW) shall be approximately 3x RBW.

5.2 Test results

NFC HF				
Frequency(MHz)	Modulation	20dB Bandwidth(kHz)	99% Bandwidth (kHz)	Limit
13.56	ASK	0.26	1.295	N/A

NFC LF			
Frequency(MHz)	Modulation	99% Bandwidth (kHz)	Limit
0.1304	ASK	0.926	N/A

5.3 Test Plots 20 dB Bandwidth(HF)

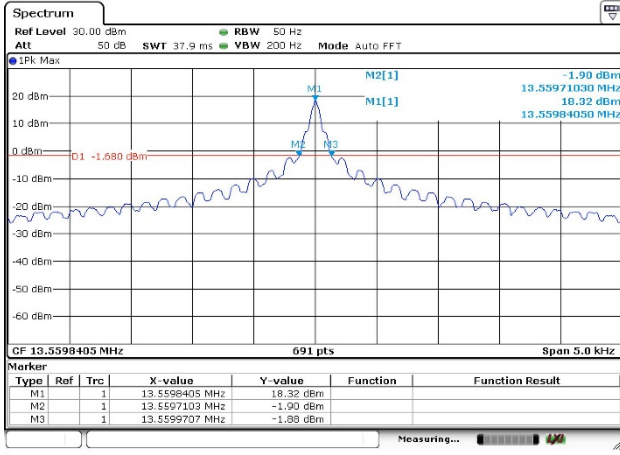

99% Bandwidth(HF)

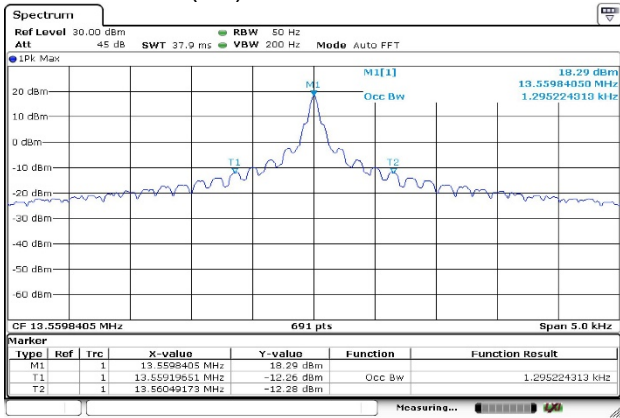

99% Bandwidth(LF)

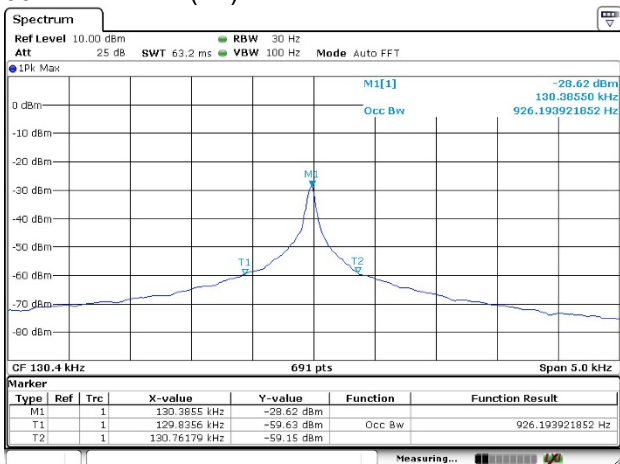

6. Frequency Tolerance

6.1 Frequency stability Data (Adapter)

Operating Frequency : 13,560,000 Hz
 Reference Voltage : 24.0 Vd.c.
 Deviatin Limit : ± 0.01 %

Voltage (%)	Power (Vdc)	Temperature (°C)	Frequency (Hz)	Deviation (%)
100	24.0	+20 °C(Ref)	13,559,918	-0.000605
100		-20	13,560,025	0.000184
100		-10	13,560,124	0.000914
100		0	13,560,110	0.000811
100		10	13,559,916	-0.000619
100		20	13,559,929	-0.000524
100		30	13,559,839	-0.001187
100		40	13,559,996	-0.000029
100		50	13,559,924	-0.000560
85		20.4	20	13,560,129
115	27.6	20	13,560,122	0.000900

7. Measurement of radiated disturbance

7.1 Radiated emission limits, general requirements

FCC : 47 CFR § 15.209		
Frequency (MHz)	Distance(Meters)	Field strength (uV/m)
0.009 to 0.490	300	2400/F(kHz)
0.490 to 1.705	30	24000/F(kHz)
1.705 to 30	30	30
30 to 88	3	100
88 to 216	3	150
216 to 960	3	200
> 960	3	500

ISED : RSS-GEN Section 8.9		
Frequency (MHz)	Distance(Meters)	Field strength (uA/m)
0.009 to 0.490	300	6.37/F(kHz)
0.490 to 1.705	30	63.7/F(kHz)
1.705 to 30	30	0.08
30 to 88	3	100
88 to 216	3	150
216 to 960	3	200
> 960	3	500

Operation within the band 13.110 MHz – 14.010 MHz

FCC : 47 CFR § 15.225 (a), (b), (c), (d) / ISED : RSS-210 ANNEX B.6		
Frequency (MHz)	Distance(Meters)	Field strength (uV/m)
13.553 – 13.567	30	15,848
13.410 ≤ f ≤ 13.553 13.567 ≤ f ≤ 13.71	30	334
13.110 ≤ f ≤ 13.410 13.710 ≤ f ≤ 14.010	30	106

7.2 13.56 MHz(HF)Test data(9 kHz ~ 30 MHz)

Frequency (MHz)	Reading (dB μV)	Vertical Position [Angle]	EUT Position	Height (m)	Correction Factor		Result Value(Quasi-Peak)		
					Ant Factor (dB)	Cable (dB)	Limit (dB $\mu V/m$)	Result (dB $\mu V/m$)	Margin (dB)
Below 13.110 MHz									
Noise Floor	-	-	-	-	19.48	0.5	69.5	-	-
13.110 MHz to 13.410 MHz									
Noise Floor	-	-	-	-	19.46	0.5	80.5	-	-
13.410 MHz to 13.552 MHz									
Noise Floor	-	-	-	-	19.46	0.5	90.5	-	-
13.553 MHz to 13.567 MHz									
13.5600	51.92	13.0	X	0.8	19.56	0.5	124.0	71.99	52.01
13.567 MHz to 13.710 MHz									
Noise Floor	-	-	-	-	19.45	0.5	90.5	-	-
13.710 MHz to 14.010 MHz									
Noise Floor	-	-	-	-	19.44	0.6	80.5	-	-
14.010 MHz to 30 MHz									
Noise Floor	-	-	-	-	19.44	0.6	69.5	-	-
Remark	<p>*The 30 m limit was converted to 3 m Limit using square factor(x) as it was found by measurements as follows; *3 m Limit(dBuV/m) = 20log(X)+40log(30/3)= 20log(15848)+40log(30/3) = 124 dBuV *3 m Limit(dBuV/m) = 20log(X)+40log(30/3)= 20log(30)+40log(30/3) = 69.5 dBuV</p> <p>* The EUT was measured for the worst case by rotating of antenna angle. * The EUT performed at X,Y,Z and recorded the worst data in the report.</p>								

7.3 125 kHz(LF)Test data(9 kHz ~ 30 MHz)

Frequency (kHz)	Reading (dB μV)	Horizontal Position [Angle]	Height (m)	Correction Factor		Result Value(Qeas-Peak)		
				Ant Factor (dB)	Cable (dB)	Limit (dB $\mu V/m$)	Result (dB $\mu V/m$)	Margin (dB)
130.40	50.00	180.0	0.8	19.59	0.8	105.3	70.35	34.94
Remark	<p>H : Horizontal, V : Vertical There did not measure any radiated spurious emission in the range 9 kHz to 30 MHz *There is no found Restricted bands. *The 300 m limit was converted to 3 m Limit using square factor(x) as it was found by measurements as follows; 3 m Limit(dBuV/m) = $20\log(2400/F(KHz))+40\log(300/10)= 20\log(2400/0.1304)+40\log(300/3)$</p>							

7.4 13.56 MHz(HF)Test data(30 MHz ~ 1 000 MHz)

Frequency (MHz)	Reading (dB μV)	Position (V/H)	Height (m)	Correction Factor		Result Value(Quasi-peak)		
				Ant Factor (dB)	Cable (dB)	Limit (dB $\mu V/m$)	Result (dB $\mu V/m$)	Margin (dB)
40.70	22.28	V	1.0	12.97	0.94	40.00	36.19	3.81
106.30	24.69	V	1.1	9.43	1.40	43.50	35.52	7.98
379.70	21.15	H	1.4	15.19	2.03	46.00	38.37	7.63
400.00	23.95	V	1.3	15.50	1.87	46.00	41.32	4.68
776.20	7.22	H	1.0	22.36	4.37	46.00	33.95	12.05
859.80	7.06	H	1.0	23.09	4.64	46.00	34.79	11.21
Remark	H : Horizontal, V : Vertical *Result Value = Reading + Antenna + Cable loss *Correction Factor = Ant Factor + Cable *The resolution bandwidth and video bandwidth of test receiver/spectrum analyzer is 120 kHz for Quasi-peak detection							

7.5 130.4 kHz(LF)Test data(30 MHz ~ 1 000 MHz)

Frequency (MHz)	Reading (dB μV)	Position (V/H)	Height (m)	Correction Factor		Result Value(Quasi-peak)		
				Ant Factor (dB)	Cable (dB)	Limit (dB $\mu V/m$)	Result (dB $\mu V/m$)	Margin (dB)
40.70	23.31	V	1.0	12.97	0.94	40.00	37.22	2.78
104.20	24.98	V	1.1	9.18	1.38	43.50	35.54	7.96
379.70	20.84	H	1.4	15.19	2.03	46.00	38.06	7.94
400.00	20.96	V	1.3	15.50	1.87	46.00	38.33	7.67
406.80	20.22	H	1.0	15.70	1.98	46.00	37.90	8.10
673.20	8.95	H	1.0	20.53	4.09	46.00	33.57	12.43
Remark	H : Horizontal, V : Vertical *Result Value = Reading + Antenna + Cable loss *Correction Factor = Ant Factor + Cable *The resolution bandwidth and video bandwidth of test receiver/spectrum analyzer is 120 kHz for Quasi-peak detection							

8. Measurement of conducted disturbance

According to RSS-Gen(8.8), for an intentional radiator that is designed to be connected to the public utility (AC) power line, the radio frequency voltage that is conducted back onto the AC power line on any frequency or frequencies, within the band 150 kHz to 30 MHz, shall not exceed the limits in the following table, as measured using a 50uH/50 ohm line impedance stabilization network (LISN). Compliance with the provision of this paragraph shall on the measurement of the radio frequency voltage between each power line and ground at the power terminal. The lower applies at the boundary between the frequencies ranges.

8.1 Test data (13.56 MHz HF)

Frequency (MHz)	Correction Factor		Line (H/N)	Quasi-peak Value			Average Value		
	Lisn (dB)	Cable (dB)		Limit (dB μ V)	Reading (dB μ V)	Result (dB μ V)	Limit (dB μ V)	Reading (dB μ V)	Result (dB)
0.17	0.06	0.17	H	59.83	34.81	35.04	49.83	24.52	24.75
0.19	0.05	0.16	H	58.93	34.51	34.72	48.93	23.34	23.55
0.20	0.05	0.16	N	58.00	34.38	34.59	48.00	22.74	22.95
0.39	0.04	0.19	H	57.93	34.56	34.79	47.93	26.75	26.98
0.45	0.04	0.19	N	56.81	38.52	38.75	46.81	30.37	30.60
27.18	0.23	0.46	N	56.76	29.69	30.37	46.76	12.82	13.50
Remark	H : Hot Line, N : Neutral Line *Correction Factor = Lisn + Cable *Result = Correction Factor + Reading								

(130.4 kHz LF)

Frequency (MHz)	Correction Factor		Line (H/N)	Quasi-peak Value			Average Value		
	Lisn (dB)	Cable (dB)		Limit (dB μV)	Reading (dB μV)	Result (dB μV)	Limit (dB μV)	Reading (dB μV)	Result (dB)
0.15	0.07	0.17	H	63.61	33.59	33.83	53.61	22.88	23.12
0.18	0.06	0.16	H	62.74	35.58	35.80	52.74	24.49	24.71
0.20	0.05	0.16	N	62.31	33.76	33.97	52.31	21.77	21.98
0.21	0.05	0.16	H	62.10	34.26	34.47	52.10	23.00	23.21
0.46	0.04	0.19	H	61.21	40.03	40.27	51.21	33.34	33.58
14.33	0.19	0.41	H	56.99	32.13	32.73	46.99	26.71	27.31
Remark	H : Hot Line, N : Neutral Line *Correction Factor = Lisn + Cable *Result = Correction Factor + Reading								

TEST PLOT
* Horizontal

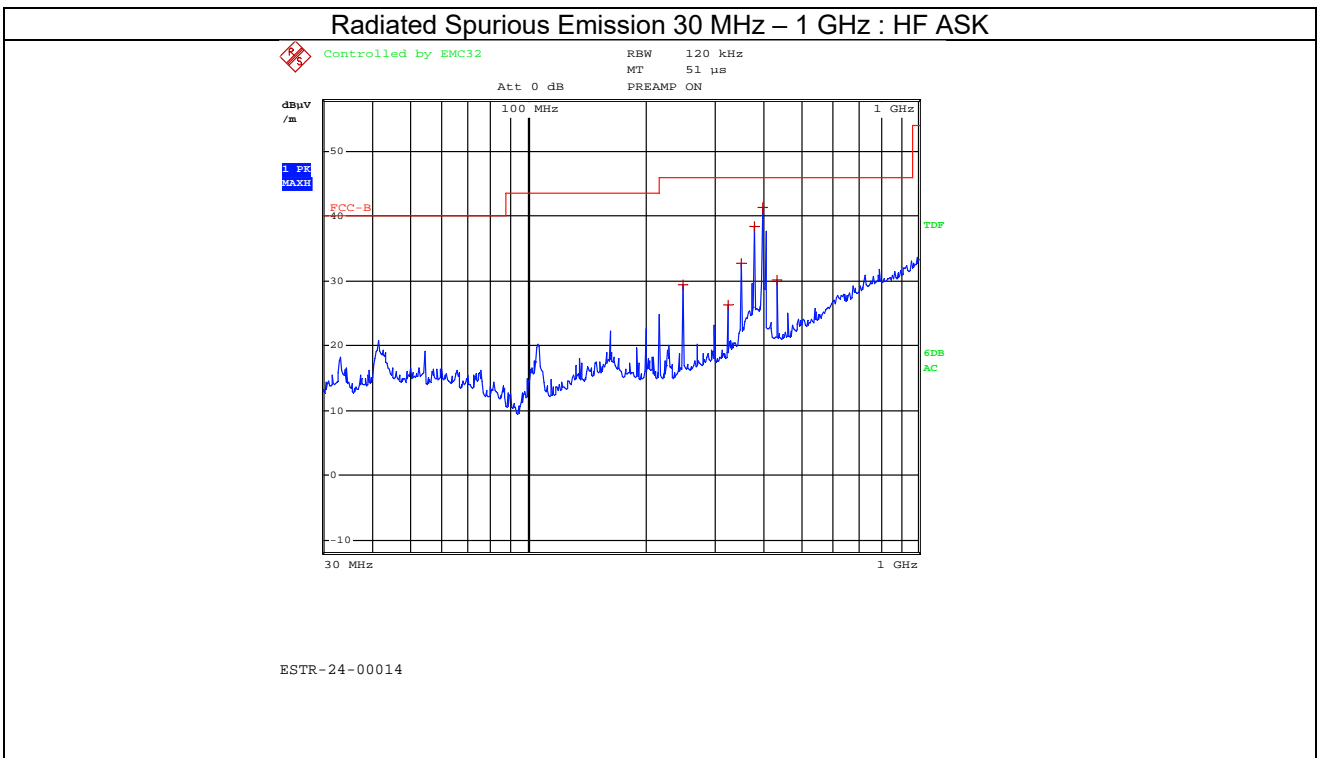
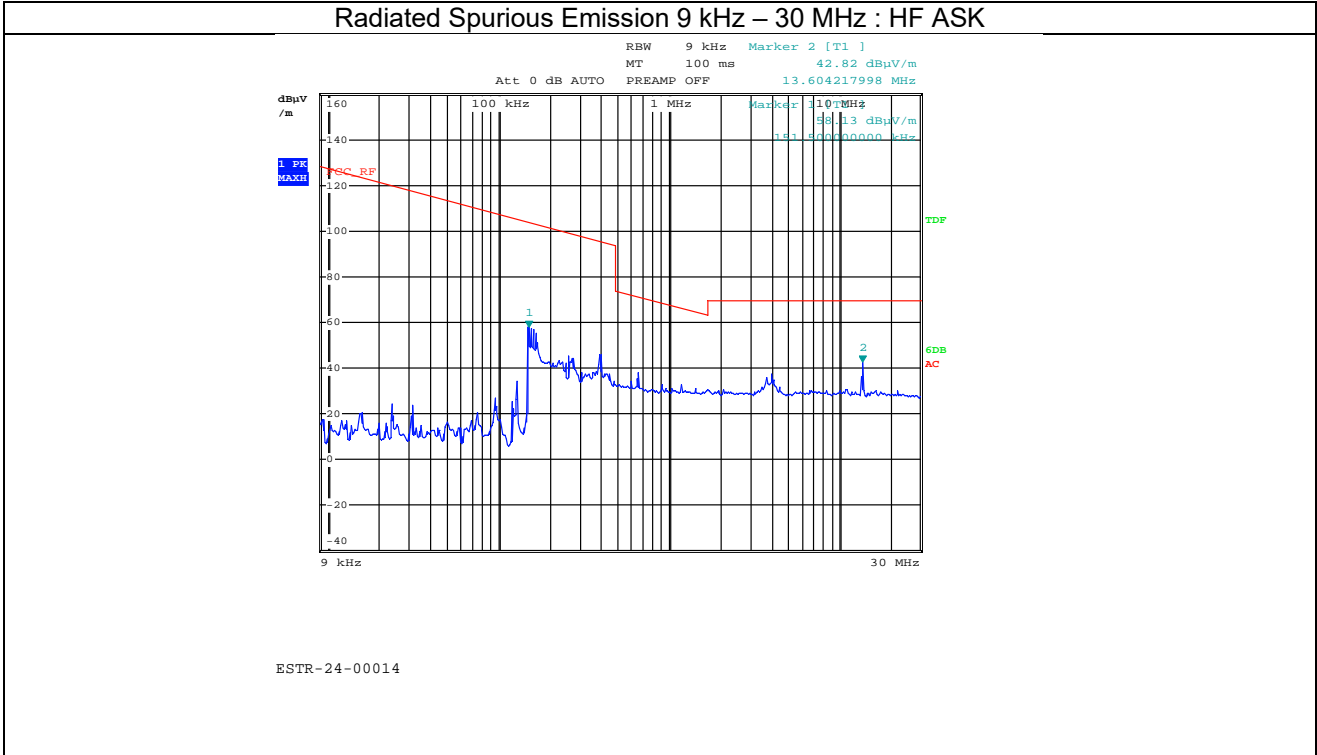

*** Horizontal**

Radiated Spurious Emission 9 kHz – 30 MHz : LF ASK

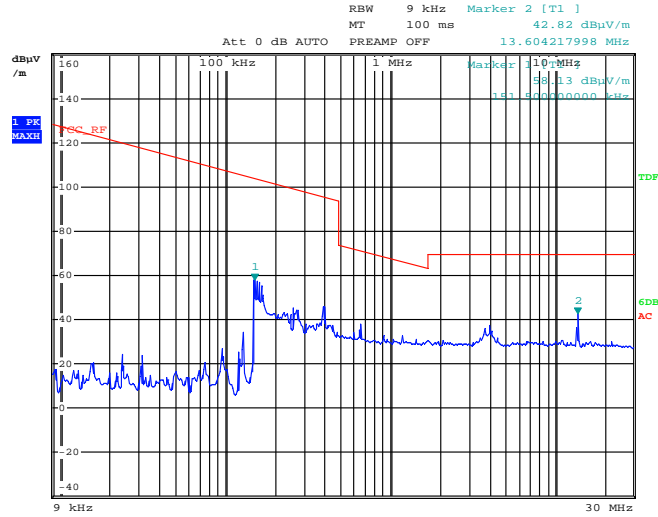

ESTR-24-00014

Radiated Spurious Emission 30 MHz – 1 GHz : LF ASK

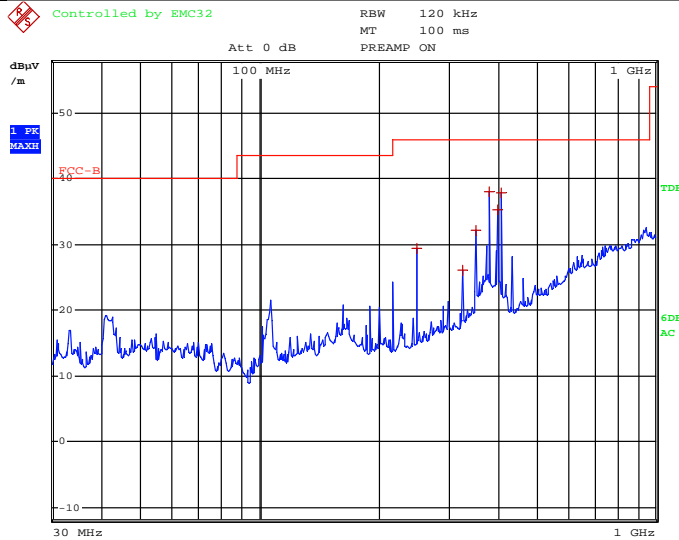

ESTR-24-00014

*** Vertical**

Radiated Spurious Emission 9 kHz – 30 MHz : LF ASK

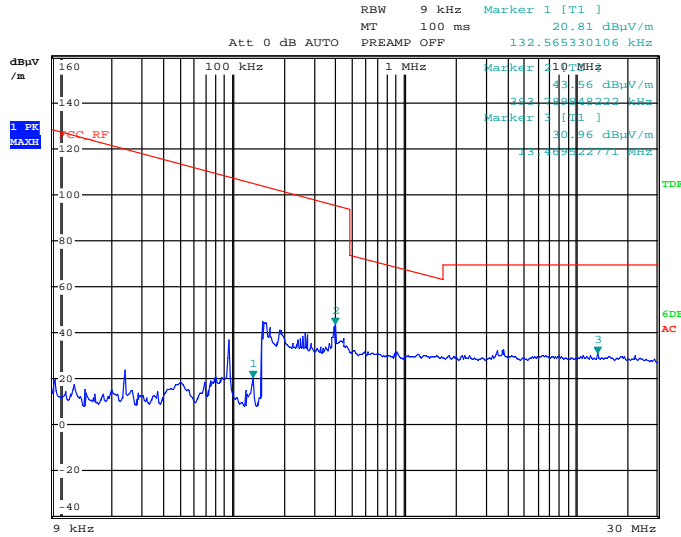

ESTR-24-00014

Radiated Spurious Emission 30 MHz – 1 GHz : LF ASK

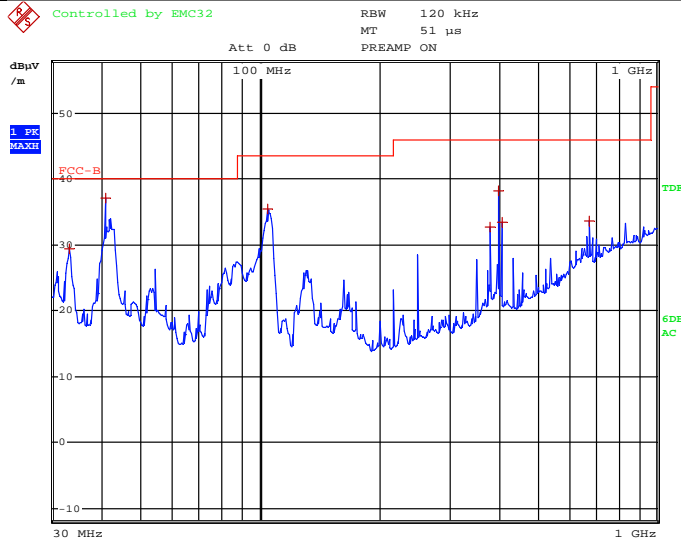

ESTR-24-00014

*** HOT LINE**

AC Line Conducted Emission Device with antenna connected(HF)

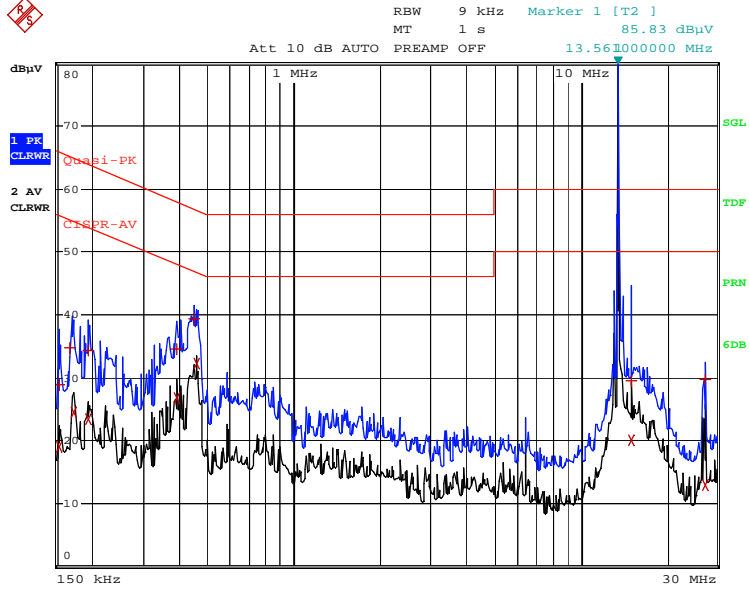

Comment : ESTR-24-00014

*** NEUTRAL LINE**

AC Line Conducted Emission Device with antenna connected(HF)

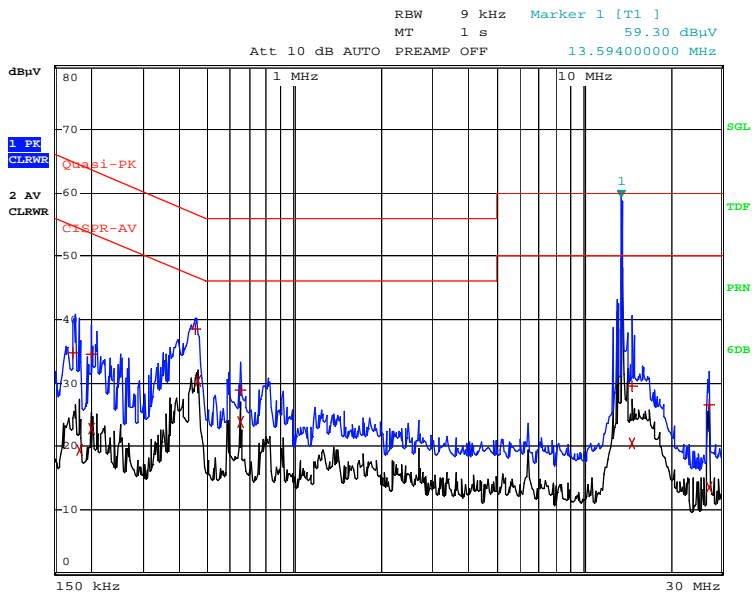

Comment : ESTR-24-00014

*** HOT LINE**

AC Line Conducted Emission Device with antenna connected(LF)

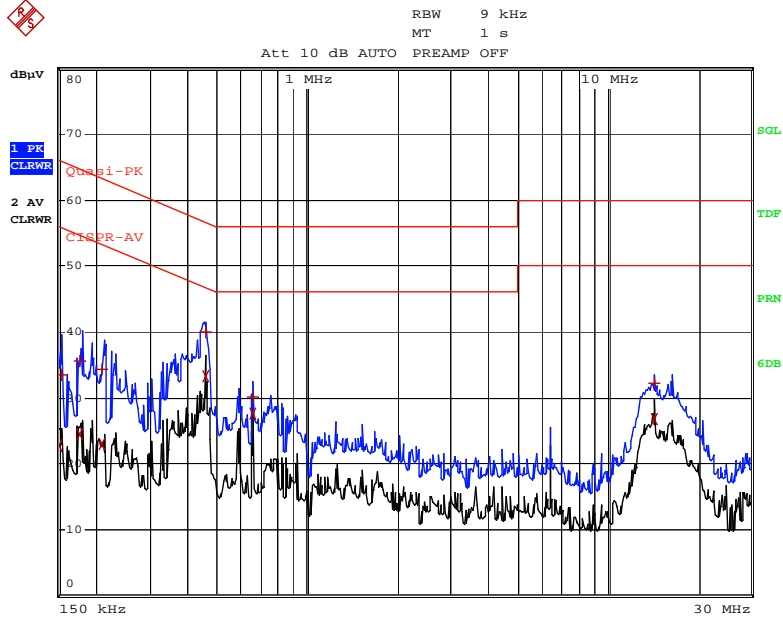

Comment : ESTR-24-00014

*** NEUTRAL LINE**

AC Line Conducted Emission Device with antenna connected(LF)

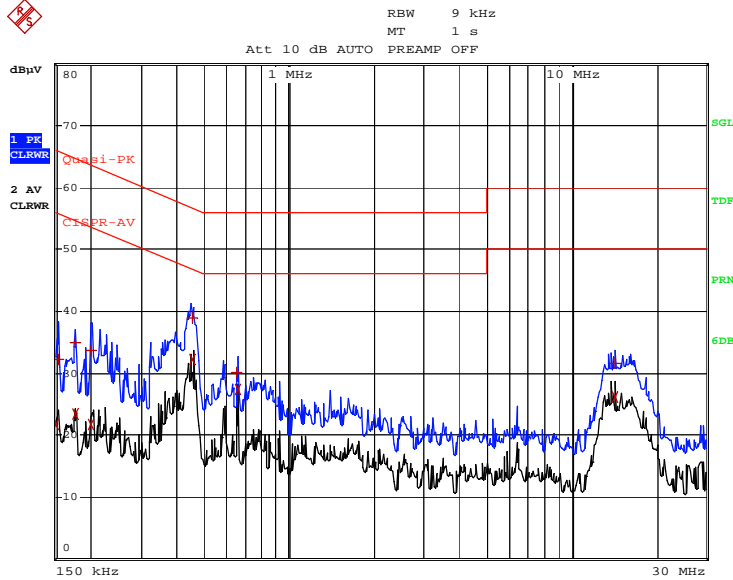

Comment : ESTR-24-00014