



Test Report for FCC

FCC ID:TKWFS2-D

Report Number		ESTEFC1703-001			
Applicant	Company name	Suprema Inc			
	Address	16F Parkview office Tower, Jeongja-dong, Bundang-gu, Seongnam, Gyeonggi			
	Telephone	+31-710-4908			
	Contact Person	Kyung-jin Hong			
	Factory address	16F Parkview office Tower, Jeongja-dong, Bundang-gu, Seongnam, Gyeonggi			
Product	Product name	Face Station2			
	Model No.	FS2-D	Manufacturer	Suprema Inc	
	Serial No.	NONE	Country of origin	Korea	
Test date	12-Feb-17		Date of issued	16-Mar-17	
Test location	347-69, Jungbu-daero 147beon-gil, Majang-myeon, Icheon-si, Gyeonggi-do 467-811, R. O. Korea				
Standard	FCC PART 15 Subpart B , ANSI C 63.4(2014)				
Test item	<input checked="" type="checkbox"/> Conducted Emission	<input type="checkbox"/> Class A	<input checked="" type="checkbox"/> Class B	Test result	OK
	<input checked="" type="checkbox"/> Radiated Emission	<input type="checkbox"/> Class A	<input checked="" type="checkbox"/> Class B	Test result	OK
Measurement facility registration number		659627			
Tested by	Senior Engineer S.B. Lee		(Signature)		
Reviewed by	Engineering Manager J.M. Yang		(Signature)		
Abbreviation	OK, Pass = Complied, Fail = Failed, N/A = not applicable				
<p>* Note</p> <p>- This test report is not permitted to copy partly without our permission</p> <p>- This test result is dependent on only equipment to be used</p> <p>- This test result based on a single evaluation of one sample of the above mentioned</p>					

Contents

1. Laboratory Information	3
2. Description of EUT	4
3. Test Standards	5
4. Measurement condition	6
5. Measurement of radiated emission	8
5.1 Measurement equipment	8
5.2 Environmental conditions	8
5.3 Test data(below 1 GHz)	9-1
5.4 Test data(above 1 GHz)	9-2
6. Measurement of conducted emission	10
6.1 Measurement equipment	10
6.2 Environmental conditions	10
6.3 Test data	11
7. Photographs of test setup	12
8. Photographs of EUT	14

Appendix 1. Special diagram



1. Laboratory Information

1.1 General

This EUT (Equipment Under Test) has been shown to be capable of compliance with the applicable technical standards and is tested in accordance with the measurement procedures as indicated in this report. ESTECH Lab attests to accuracy of test data. All measurement reported herein were performed by ESTECH Co., Ltd.

ESTECH Lab assume full responsibility for the completeness of these measurements and vouch for the qualifications of all persons taking them.

1.2 Test Lab.

Corporation Name : ESTECH Co., Ltd.

Head Office : Suite 1015 World Meridian II, 123 Gasan Digital 2-ro, Geumcheon-gu, Seoul 153-759, R. O. Korea

EMC Test Lab : 347-69, Jungbu-daero 147beon-gil, Majang-myeon, Icheon-si,
Gyeonggi-do 467-811, R. O. Korea

1.3 Official Qualification(s)

MSIP : Granted Accreditation from Ministry of Information & Communication for EMC, Safety
and Telecommunication

KOLAS : Accredited Lab By Korea Laboratory Accreditation Schema base on CENELEC
requirements

FCC : Conformity Assessment Body(CAB) with registration number 659627 under APEC TEL MRA
between the RRA and the FCC.

VCCI : Granted Accreditation from Voluntary Control Council for Interference from ITE

2. Description of EUT

2.1 Summary of Equipment Under Test

Product : Face Station2
 Model Number : FS2-D
 Serial Number : NONE
 Manufacturer : Suprema Inc
 Country of origin : Korea
 Sample Receipt Date : 5-Jan-17
 Rating : ADAPTER INPUT : AC (100 ~ 240) V , (50 ~ 60) Hz, 1.0 A
 : ADAPTER OUTPUT : DC 12.0 V, 2.5 A
 Testing Voltage : AC 120 V, 60 Hz
 " X-tallist(s) or
 Frequencies : CPU 1.40 GHz
 generated

2.2 General descriptions of EUT

Category	Feature	Specification
Credential	Biometric	Face
	RF Option	<ul style="list-style-type: none"> IFS2-D: EM, MIFARE, MIFARE Plus, DESFire/EV1, FeliCa, NFC, ISO14443A, ISO15693 IFS2-AWB: EM, HID Prox, MIFARE, MIFARE Plus, DESFire/EV1, FeliCa, iCLASS SE/SR, NFC, BLE, ISO14443A, ISO15693
	RF read range*	MIFARE/DESFire/iCLASS/ISO15693 : 50 mm / EM/HID Prox/Felica: 30 mm, BLE: 50 mm
General	LFD	Supported
	CPU	1.4 GHz Quad Core
	Memory	8GB Flash + 1GB RAM
	LCD type	4" color TFT touch
	LCD resolution	800 x 480
	Sound	24 bit/Voice DSP (echo cancel)
	Operating temperature	-20 °C - 50 °C
	Storage temperature	-40 °C - 70 °C
	Operating humidity	0% - 80%, non-condensing
	Storage humidity	0% - 90%, non-condensing
	Camera type	CMOS
	Camera resolution	720 x 480
	Camera angle	Visual Lens: Diagonal 92.7° IR Lens: Diagonal 58°
	Dimension (W x H x D)	141 mm x 164 mm x 125 mm
Weight	Device	628 g
	Bracket	74 g (including washer and bolt)
Capacity	Certificates	CE, FCC, KC, RoHS, REACH, WEEE
	Max. User (1:1)	30,000
	Max. User (1:N)	3,000
	Max. Template (1:1)	900,000
	Max. Template (1:N)	90,000
	Max. Image Log	50,000
Interface	Wi-Fi	Supported (Built-in, IEEE802.11 b/g/n)
	Ethernet	Supported (10/100/1000 Mbps, auto MDI/MDI-X)
	RS-485	1ch Host or Slave (Selectable)
	Wiegand	1ch Input, 1ch Output
	TTL input	1ch Input
	Relay	1 Relay
	USB	USB 2.0 (Host)
	Tamper	Supported
Electrical	Power	Voltage: 12 VDC Current: Max. 2.5 A
	Switch input WH	Min.: 3 V Max.: 5 V
	Switch input WL	Max.: 1 V
	Switch Pull-up resistance	4.7 kΩ (The input pots are pulled up with 4.7 kΩ)
	Wiegand output VOH	More than 4.8 V
	Wiegand output VOL	Less than 0.2 V
	Wiegand output Pull-up resistance	Internally pulled up with 1 kΩ
Relay	Voltage: Max. 30 VDC Current: Max. 1 A	



3. Test Standards

Test Standard : FCC PART 15 Subpart B

This Standard sets out the regulations under which an intentional, unintentional, or incidental radiator may be operated without an individual license. It also contains the technical specifications, administrative requirements and other conditions relating to the marketing of Part 15 devices.

Test Method : ANSI C 63.4 (2014)

This standard sets forth uniform methods of measurement of radio-frequency (RF) signals and noise emitted from both unintentional and intentional emitters of RF energy in the frequency range 9 kHz to 40 GHz. Methods for the measurement of radiated and AC power-line conducted radio noise are covered and may be applied to any such equipment unless otherwise specified by individual equipment requirements. These methods cover measurement of certain devices that deliberately radiate energy, such as intentional emitters, but does not cover licensed transmitters. This standard is not intended for certification/approval of avionic equipment or for industrial, scientific, and medical (ISM) equipment. These methods apply to the measurement of individual units or systems comprised of multiple units.

4. Measurement Condition

4.1 EUT Operation.

- The EUT was in the following operation mode during all testing.
- 1. Monitor the operation status of the apparatus under test using the supplier program.
- 2. Connected with Door Module to monitor operation status.
- 3. Connect LAN cable to switch to send / receive ping data.

4.2 Configuration and Peripherals

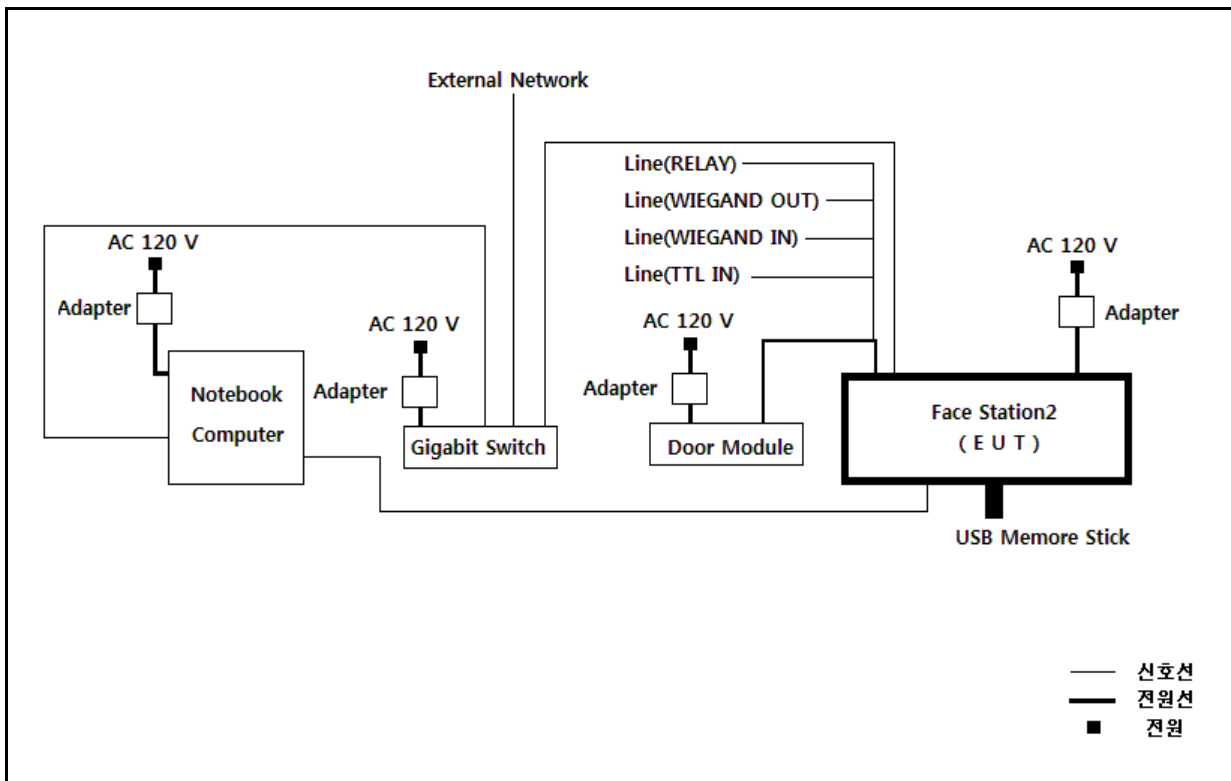

4.3 EUT and Support equipment

Equipment Name	Model Name	S/N	Manufacturer	Remark (FCC ID)
Face Station2	FS2-D	NONE	Suprema Inc	EUT
Adapter	JPW128KA1200N05	NONE	BridegPower Corp.	2ea
Door Module	DM-20	10000047	Suprema Inc	
Gigabit Switch	DGS-1005D	DRC9C97006728	D-LINK CORPORATION	
Adapter	AD-071AB	NONE	OUTSTANDING ELECTRONICS MANUFACTURER CO., LTD.	
Notebook Computer	LG15N54	412NZHH305305	LG Electronics	
Adapter	PA-1900-14	NONE	LITE-ON TECHNOLOGY (CHANGZHOU)CO., LTD.	
USB Memory Stick	NONE	NONE	memorette.	

4.4 Cable Connecting

Start Equipment		End Equipment		Cable Standard		Remark
Name	I/O port	Name	I/O port	Length	Shielded	
Face Station2	Power	Adapter	-	2.0	Unshielded	
Face Station2	LAN	Gigabit Switch	LAN	3.0	Unshielded	
Face Station2	Line(RS-485)	Door Module	Line(RS-485)	3.0	Shielded	
Face Station2	Line(RELAY)	-	-	3.0	Shielded	
Face Station2	Line (WIEGAND IN)	-	-	3.0	Shielded	
Face Station2	Line (WIEGAND OUT)	-	-	3.0	Shielded	
Face Station2	Line(TTL IN)	-	-	3.0	Shielded	
Face Station2	USB	USB Memory Stick	USB	-	-	
Face Station2	MicroUSB	Notebook Computer	USB	2.0	Shielded	
Notebook Computer	Power	Adapter	-	2.0	Shielded	
Door Module	Power	Adapter	-	2.0	Unshielded	
Gigabit Switch	Power	Adapter	-	2.0	Unshielded	
Gigabit Switch	LAN	External Network	-	20.0	Unshielded	
Notebook Computer	LAN	Gigabit Switch	LAN	3.0	Unshielded	

5. Measurement of radiated disturbance

Above 30 MHz Electric Field strength was measured in accordance with FCC PART 15 Subpart B. The test setup was made according to ANSI C 63.4 (2014) on an 10 m semi-anechoic chamber, which allows a 3 m distance measurement. The EUT was placed in the center of Plastic table. The height of this table was 0.8 m. The measurement was conducted with both horizontal and vertical antenna polarization. The turntable has fully rotated. For further description of the configuration refer to the picture of the test setup.

5.1 Measurement equipments

Equipment Name	Type	Manufacturer	Serial No.	Next Calibration date
TEST Receiver	ESCI7	ROHDE & SCHWARZ	100916	14-Nov-17
Logbicon Antenna	VULB 9168	SCHWARZBECK	237	13-May-17
Turn Table	DT3000-2t	Innco System GmbH	N/A	N/A
Antenna Mast	MA4000-EP	Innco System GmbH	N/A	N/A
PREAMPLIFIER	8449B	AGILENT	3008A00581	14-Nov-17
Test Receiver	ESPI7	ROHDE & SCHWARZ	100185	14-Nov-17
Horn Antenna	BBHA9120D	SCHWARZBECK	469	25-Aug-18
Spectrum Analyzer	R3273	ADVANTEST	110600592	21-Oct-17
Turn Table	DT1500-S	Innco System GmbH	N/A	N/A
Antenna Mast	MA4640-XP-ET	Innco System GmbH	N/A	N/A
Antenna Master & Turn table controller	C02000-P	Innco System GmbH	CO2000/642 /28051111/L	N/A

5.2 Environmental Condition

Below 1 GHz –Test Place : 10 m Semi-anechoic chamber

Temperature (°C) : 21.0 °C
 Humidity (% R.H.) : 53.9 % R.H.

Above 1 GHz–Test Place : 3 m Semi-anechoic chamber

Temperature (°C) : 22.9 °C
 Humidity (% R.H.) : 53.9 % R.H.

5.3 Test data (Below 1 GHz)

Test Date : 12-Feb-17

Measurement Distance : 3 m

Frequency (MHz)	Reading (dB μ V)	Position (V/H)	Height (m)	Correction Factor		Result Value(Quasi-peak)		
				Ant Factor (dB)	Cable (dB)	Limit (dB μ V/m)	Result (dB μ V/m)	Margin (dB)
52.30	13.86	V	1.0	13.80	1.14	40.00	28.80	11.20
83.30	22.34	V	1.0	8.81	1.44	40.00	32.59	7.41
162.70	15.06	V	1.0	13.09	2.02	43.50	30.17	13.33
192.00	19.19	V	1.0	10.42	2.20	43.50	31.81	11.69
400.00	23.47	H	1.0	15.60	3.23	46.00	42.30	3.70
762.90	7.12	V	1.0	21.93	4.56	46.00	33.61	12.39
Remark	<p>H : Horizontal, V : Vertical *Result Value = Reading + Ant Factor + Cable loss *Margin= Limit - Result *The resolution bandwidth and video bandwidth of test receiver/spectrum analyzer is 120 kHz for Quasi-peak detection</p>							

5.4 Test data (Above 1 GHz)

Test Date : 12-Feb-17

Measurement Distance :

3 m

Frequency (MHz)	Reading (dB μ V)	Position (V/H)	Height (m)	Correction Factor		Result Value		
				Ant Factor (dB)	Cable (dB)	Limit (dB μ V/m)	Result (dB μ V/m)	Margin (dB)
Peak(RBW:1 MHz VBW:1 MHz)								
1001.00	46.47	H	1.0	25.41	-32.85	74.00	39.03	34.97
1001.00	46.66	V	1.0	25.41	-32.85	74.00	39.22	34.78
2448.00	45.00	H	1.0	27.84	-29.99	74.00	42.85	31.15
2448.00	51.88	V	1.0	27.84	-29.99	74.00	49.73	24.27
3500.00	51.96	H	1.0	29.04	-28.62	74.00	52.38	21.62
3500.00	45.33	V	1.0	29.04	-28.62	74.00	45.75	28.25
Average(RBW:1 MHz VBW:10 Hz)								
1001.00	38.78	H	1.0	25.41	-32.85	54.00	31.34	22.66
1001.00	39.94	V	1.0	25.41	-32.85	54.00	32.50	21.50
2448.00	34.69	H	1.0	27.84	-29.99	54.00	32.54	21.46
2448.00	38.15	V	1.0	27.84	-29.99	54.00	36.00	18.00
3500.00	44.92	H	1.0	29.04	-28.62	54.00	45.34	8.66
3500.00	37.98	V	1.0	29.04	-28.62	54.00	38.40	15.60
Remark	<p>H : Horizontal, V : Vertical * Result Value = Reading + Ant Factor + Cable loss - Amplifier Gain * Margin= Limit - Result * The resolution bandwidth and video bandwidth of spectrum analyzer is 1 MHz and 10 Hz for average detection at frequency above 1 GHz. *The highest operating frequency of the EUT is 1.4 GHz , so the radiated emission measurement was performed up to 7 GHz by requested applicant. *Application method of the highest frequency is in the following *Highest frequency of the EUT is less than 108 MHz, the measurement shall only be made up to 1 GHz. *Highest frequency of the EUT is between 108 MHz and 500 MHz, the measurement shall only be made up to 2 GHz. *Highest frequency of the EUT is between 500 MHz and 1 GHz, the measurement shall only be made up to 5 GHz. *Highest frequency of the EUT is above 1 GHz, the measurement shall be made up to 5 times the highest frequency or 40 GHz,</p>							

6. Measurement of conducted disturbance

The continuous disturbance voltage of AC Mains in the frequency from 0.15 MHz to 30 MHz was measured in accordance to FCC PART 15 Subpart B . The test setup was made according to ANSI C 63.4 (2014) in a shielded room. The EUT was placed on a non-conductive table at least 0.8 m above the ground plan. A grounded vertical reference plane was positioned in a distance of 0.4 m from the EUT. The distance from the EUT to other metal surfaces was at least 0.8 m. The EUT was only earthen by its power cord through the line impedance stabilizing network. The power cord has been bundled to a length of 1.0 m. The test receiver with Quasi Peak detector complies with CISPR 16.

6.1 Measurement equipments

Equipment Name	Type	Manufacturer	Serial No.	Next Calibration date
Test Receiver	ESPI	Rohde & Schwarz	100005	14-Nov-17
LISN	ENV 216	ROHDE & SCHWARZ	101231	22-Aug-17
LISN	ESH3-Z5	Rohde & Schwarz	836679/025	14-Nov-17
Pulse Limiter	ESH3-Z2	Rohde & Schwarz	NONE	14-Nov-17

6.2 Environmental Condition

Test Place : Shielded Room

Temperature (°C) : 21.4 °C

Humidity (% R.H.) : 52.2 % R.H.

6.3 Test data

Test Date : 12-Feb-17

Frequency (MHz)	Correction Factor		Line (H/N)	Quasi-peak Value			Cispr Average Value		
	Lisn (dB)	Cable (dB)		Limit (dB μ V)	Reading (dB μ V)	Result (dB μ V)	Limit (dB μ V)	Reading (dB μ V)	Result (dB)
0.20	0.09	0.20	N	63.69	47.24	47.53	53.69		
0.33	0.09	0.20	N	59.45	41.61	41.90	49.45		
0.53	0.16	0.21	H	56.00	39.79	40.16	46.00		
0.59	0.09	0.21	N	56.00	49.64	49.95	46.00	38.45	38.76
0.66	0.10	0.22	N	56.00	45.81	46.13	46.00	35.74	36.06
22.16	0.59	0.34	N	60.00	42.91	43.83	50.00		
Remark	H : Hot Line, N : Neutral Line *Correction Factor = Lisn + Cable *Result = Correction Factor + Reading								

7. Photographs of test setup

7.1 Setup for Radiated Test : (30 ~ 1 000) MHz

[Front]

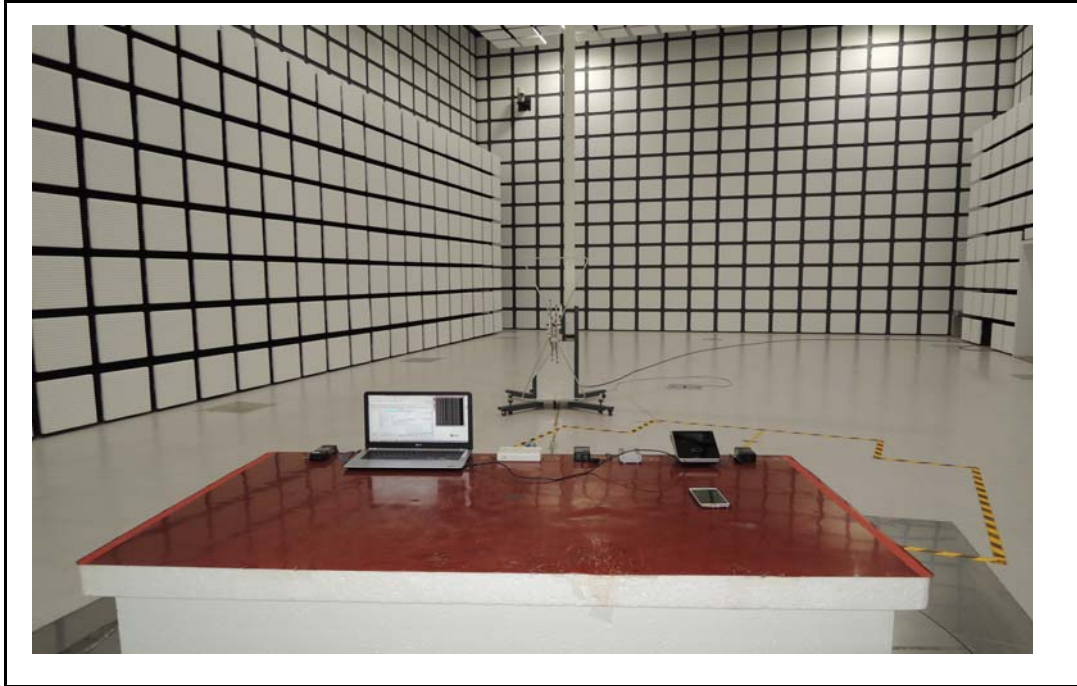

[Rear]

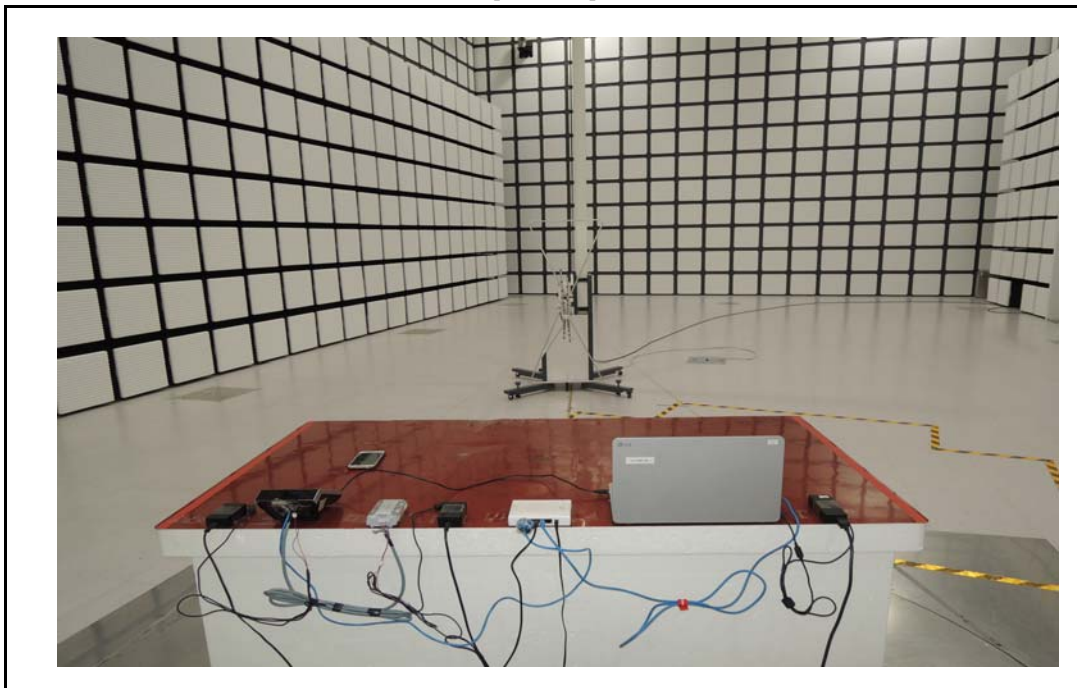

7.2 Setup for Radiated Test : above 1 GHz
[Front]



[Rear]

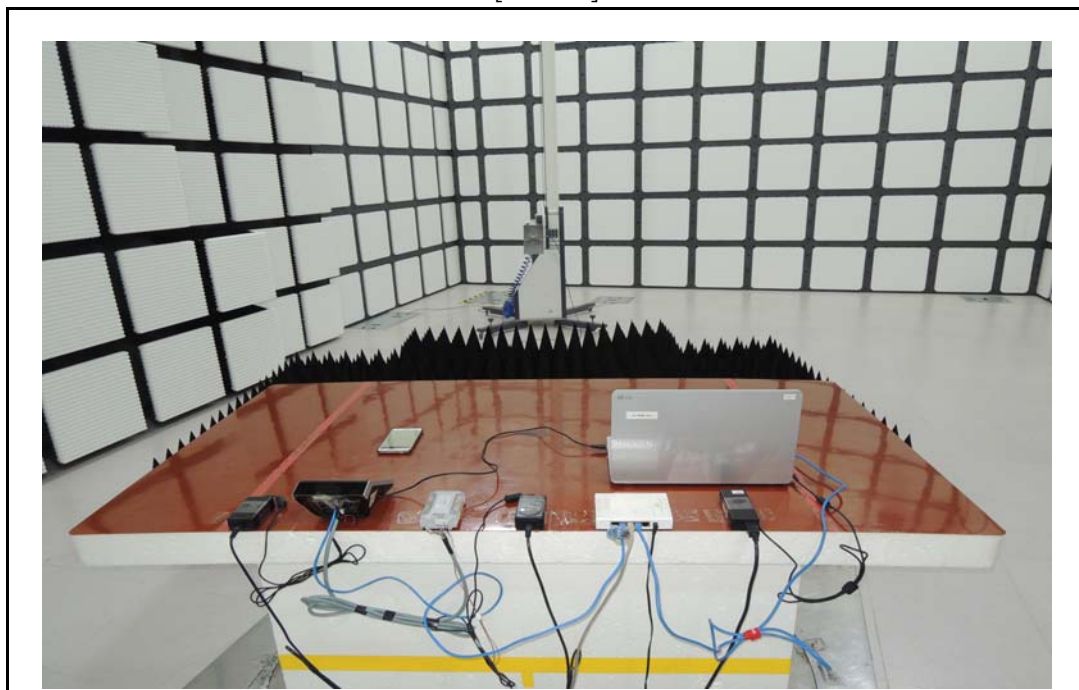

7.3 Setup for Conducted Test : (0.15 ~ 30) MHz

[Front]



[Rear]



8. Photographs of EUT

[Front]



[Rear]



Appendix 1. Special diagram

*HOT

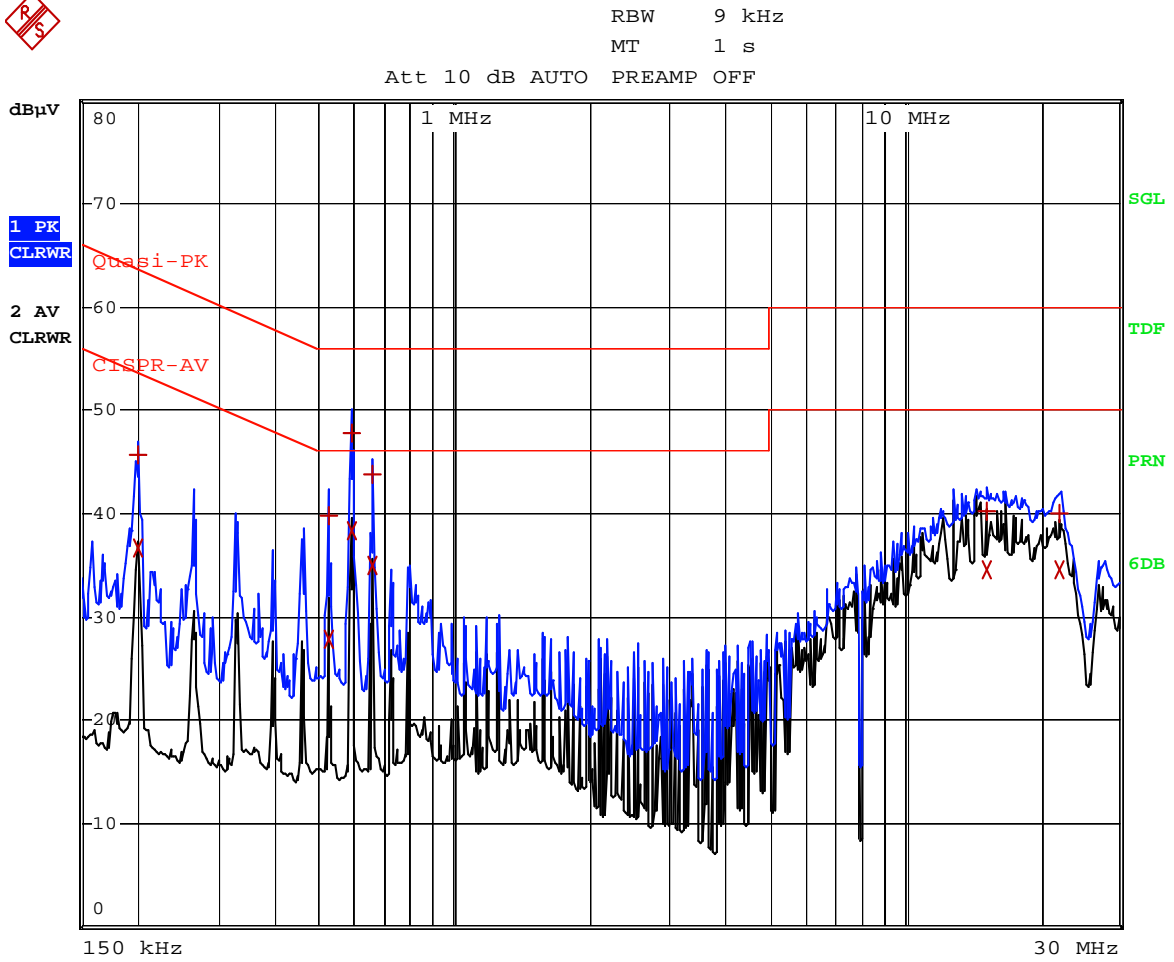

Comment: 01109-HOT

Date: 12.FEB.2017 06:28:13

*NEUTRAL



RBW 9 kHz

MT 1 s

Att 10 dB AUTO PREAMP OFF

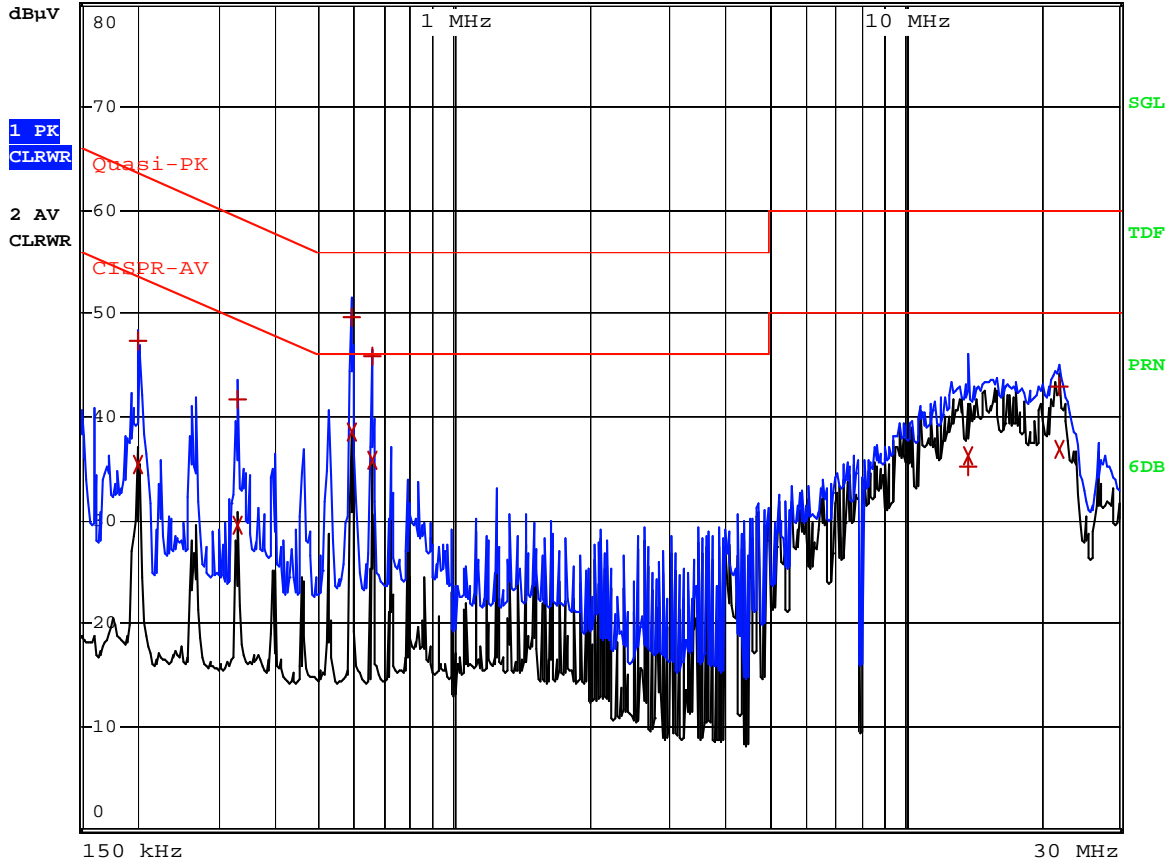

Comment: 01109-NEUTRAL

Date: 12.FEB.2017 06:30:38