



Test Report for FCC

FCC ID : TKWFL-DB

Report Number		ESTRFC1906-001			
Applicant	Company name	Suprema Inc			
	Address	16F, Parkview Office Tower, 248, Jeongjail-ro, Bundang-gu, Seongnam, Gyeonggi, South Korea			
	Telephone	+82-31-710-4908			
Product	Product name	Facelite			
	Model No.	FL-DB	Manufacturer	Suprema Inc	
	Serial No.	NONE	Country of origin	KOREA	
Test date	20-May-19 ~ 21-May-19		Date of issue	10-Jun-19	
Testing location	347-69, Jungbu-daero 147beon-gil, Majang-myeon, Icheon-si, Gyeonggi-do 467-811, R. O. Korea				
Standard	FCC PART 15 Subpart C(15.209), ANSI C 63.10(2013)				
Test item	<input checked="" type="checkbox"/> Conducted Emission	<input type="checkbox"/> Class A	<input checked="" type="checkbox"/> Class B	Test result	OK
	<input checked="" type="checkbox"/> Radiated Emission	<input type="checkbox"/> Class A	<input checked="" type="checkbox"/> Class B	Test result	OK
Measurement facility registration number		659627			
Tested by	Engineer H.G. Lee		(Signature)		
Reviewed by	Engineering Manager I.K. Hong		(Signature)		
Abbreviation	OK, Pass = Complied, Fail = Failed, N/A = not applicable				
<p>* Note</p> <ul style="list-style-type: none"> - This test report is not permitted to copy partly without our permission - This test result is dependent on only equipment to be used - This test result based on a single evaluation of one sample of the above mentioned - There are two power sources, one of which is selected and tested(24 V) 					



Contents

1. Laboratory Information	3
2. Description of EUT	4
3. Test Standards	6
4. Measurement condition	7
5. Measurement of radiated emission	9
5.1 Radiated emission limits, general requirements	9
5.2 Measurement equipment	9
5.3 Environmental conditions	9
5.4 Test data	10
6. Measurement of conducted emission	12
6.1 Measurement equipment	12
6.2 Environmental conditions	12
6.3 Test data	13

Appendix 1. Special diagram
Appendix 2. Antenna Requirement



1. Laboratory Information

1.1 General

This EUT (Equipment Under Test) has been shown to be capable of compliance with the applicable technical standards and is tested in accordance with the measurement procedures as indicated in this report. ESTECH Lab attests to accuracy of test data. All measurement reported herein were performed by ESTECH Co., Ltd.

ESTECH Lab assume full responsibility for the completeness of these measurements and vouch for the qualifications of all persons taking them.

1.2 Test Lab.

Corporation Name : ESTECH Co., Ltd.

Head Office : Suite 1015 World Meridian II, 123 Gasan Digital 2-ro, Geumcheon-gu,
Seoul 153-759, R. O. Korea

EMC/Telecom/Safety Test Lab : 347-69, Jungbu-daero 147beon-gil, Majang-myeon, Icheon-si,
Gyeonggi-do 467-811, R. O. Korea

1.3 Official Qualification(s)

KCC : Granted Accreditation from Ministry of Information & Communication for EMC, Safety
and Telecommunication

KOLAS : Accredited Lab By Korea Laboratory Accreditation Schema base on CENELEC

FCC : Filed Laboratory at Federal Communications Commission

VCCI : Granted Accreditation from Voluntary Control Council for Interference from ITE



2. Description of EUT

2.1 Summary of Equipment Under Test

Product : Facelite
Model Number : FL-DB
Serial Number : NONE
Manufacturer : Suprema Inc.
Country of origin : KOREA
Operating Frequency : 112.9 kHz
Antenna Type : PCB Antenna
Modulation Type : ASK
Channel Spacing : 1

Power Rating : INPUT: AC(100 – 240) V, (50–60)Hz, 1.7 A
: OUTPUT: DC 24 V, 2.5 A

Receipt Date : 25-Mar-19

X-tal list(s) or Frequencies generated : The highest operating frequency is NFC 112.9 kHz

2.2 General descriptions of EUT

Category	Feature	Specification
Credential	Biometric	Face
	RF Option	FL-DB: 112.9 kHz EM & 13.56 MHz MIFARE, MIFARE Plus, DESFire/EV1, FeliCa, NFC & 2.4 GHz BLE
	RF read range*	MIFARE/DESFire: 50 mm, EM/Felica: 30 mm, BLE: 50 mm
	LFD	Supported
General	CPU	1.2 GHz Quad Core
	Memory	8GB Flash + 1GB RAM
	LCD type	2" color TFT LCD
	Sound	24 bit Voice DSP
	Operating temperature	-20 °C – 50 °C
	Storage temperature	-40 °C ~ 70 °C
	Operating humidity	0 % – 80 %, non-condensed
	Dimension (W x H x D)	80 mm x 160.3 mm x 71.8 mm
	Weight	Device: 296 g Bracket: 41 g (Including washer and bolt)
Interface	Wi-fi	Not Supported
	Ethernet	Supported (10/100 Mbps, auto MDI/MDI-X)
	RS-485	1 ch Host or Slave (Selectable)
	Wiegand	1 ch Input / Output (Selectable)
	TTL input	2 ch Input
	USB	USB 2.0 (Host)
	Relay	1 Relay
	Tamper	Supported
Electrical	Power	Voltage: 24 VDC, Current: Max. 2.5 A
	Switch input VIH	Min. 3V, Max. 5V
	Switch input VIL	Max. 1V
	Wiegand output Pull-up resistance	Internally pulled-up with 1 k Ω
	Switch Pull-up resistance	4.7k Ω (The input ports are pulled up with 4.7k Ω .)
	Relay	Voltage: Max. 30 VDC, Current: Max. 2A

* RF read range will vary depending on the installation environment.

3. Test Standards

Test Standard : FCC PART 15

This Standard sets out the regulations under which an intentional, unintentional, or incidental radiator may be operated without an individual license. It also contains the technical specifications, administrative requirements and other conditions relating to the marketing of Part 15 devices.

Test Method : ANSI C 63.10 (2013)

This standard sets forth uniform methods of measurement of radio-frequency (RF) signals and noise emitted from both unintentional and intentional emitters of RF energy in the frequency range 9 kHz to 40 GHz. Methods for the measurement of radiated and AC power-line conducted radio noise are covered and may be applied to any such equipment unless otherwise specified by individual equipment requirements. These methods cover measurement of certain devices that deliberately radiate energy, such as intentional emitters, but does not cover licensed transmitters. This standard is not intended for certification/approval of avionic equipment or for industrial, scientific, and medical (ISM) equipment. These methods apply to the measurement of individual units or systems comprised of multiple units.

Summary of Test Results

Applied Standard : 47 CFR Part 15, Subpart C				
Standard	Test Type	Result	Remark	Limit
15.203	Antenna Requirement	Pass	See Appendix 2	
15.207	AC Power Conducted Emission	Pass	Meet the requirement	
15.209	Radiated Emission	Pass	Meet the requirement	

4. Measurement Condition

4.1 EUT Operation.

-The EUT was tested, under transmission / receiving

1. Normal communication with RF OUT Frequency(135.4 kHz).
2. Monitoring the operation status of frequency by using RF CARD.

4.2 Configuration and Peripherals

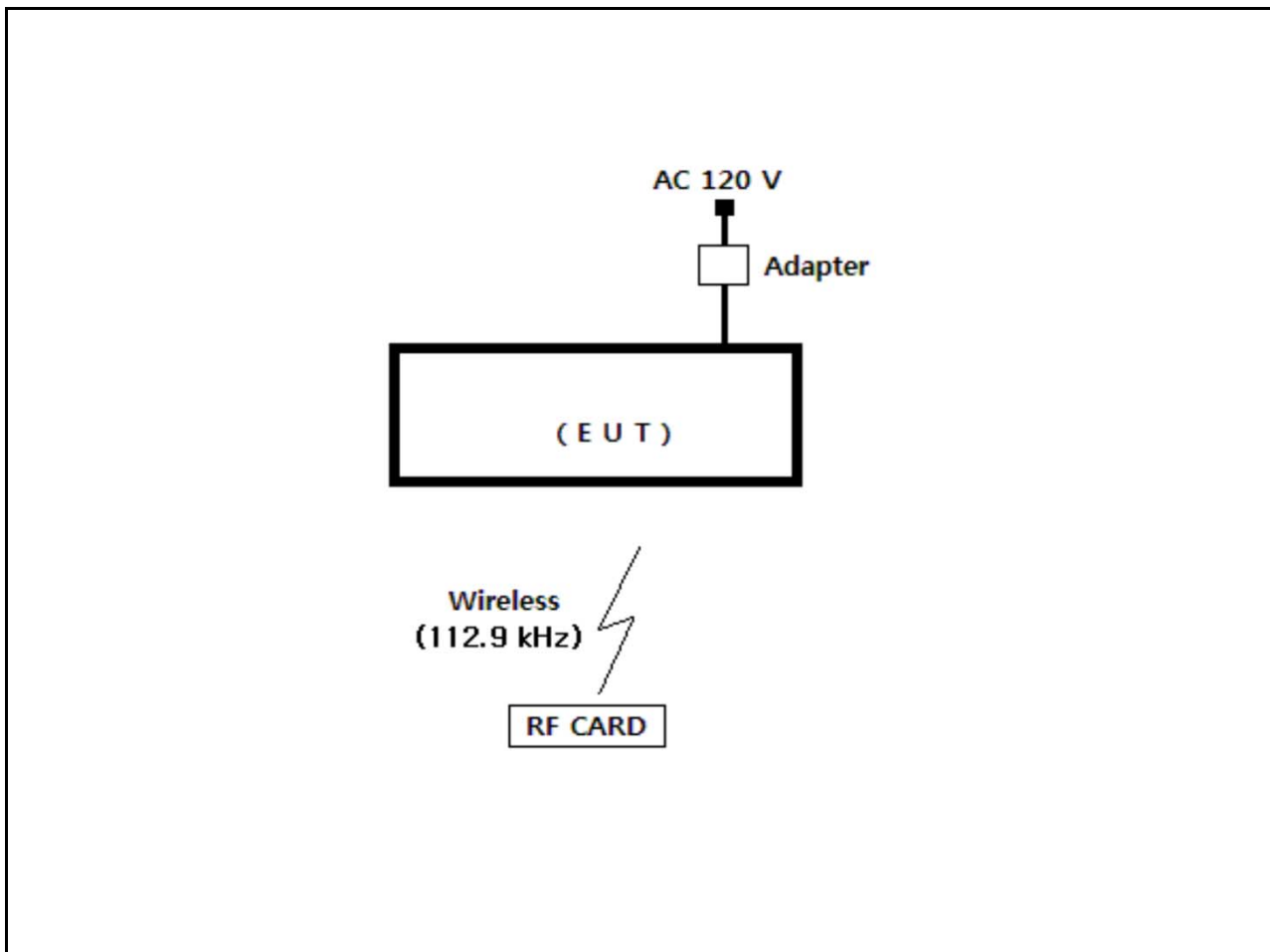



4.3 EUT and Support equipment

Equipment Name	Model Name	S/N	Manufacturer	Remark (FCC ID)
Facelite	FL-DB	NONE	Suprema Inc	EUT
Adapter	KPL-060M	NONE	Channel Well Technology(Guangzhou)Co., Ltd.	
RF CARD	NONE	NONE	Suprema Inc	

4.4 Cable Connecting

Start Equipment		End Equipment		Cable Standard		Remark
Name	I/O port	Name	I/O port	Length	Shielded	
Facelite	Power	Adapter	-	2	Unshielded	
Facelite	Wireless (112.9 kHz)	RF CARD	Wireless (112.9 kHz)	-	-	

5. Measurement of radiated disturbance

The EUT was placed on the top of a rotating table 0.8 m above the ground at a 3 m Open test site. The table was rotated 360 ° to determine the position of the highest radiation. Then antenna is a loop antenna is fixed at one meter above the ground to determine the maximum value of the field strength. Both parallel and perpendicular of the antenna are set to make the measurement. For each suspected emission, the EUT was arranged to its worst case and then the table was turned from 0 degrees to 360 ° to find the maximum reading. The test-receiver system was set to Peak Detect Function and Specified Bandwidth with Maximum Hold Mode.

5.1 Radiated emission limits, general requirements

Except as provided elsewhere in this Subpart, the emissions from an intentional radiator shall not exceed the field strength levels specified in the following table:

Frequency (MHz)	Field Strength(microvolt/meter)	Distance(meter)
0.009-0.490	2400/F(KHz)	300
0.490-1.705	24000/F(KHz)	30
1.705-30	30	30
30-88	100**	3
88-216	150**	3
216-960	200**	3
Above 960	500	3

* dBuV/m=20*log(uV/m) * Distance factor=40dB / decade(15.31(f))

5.2 Measurement equipments

Equipment Name	Type	Manufacturer	Serial No.	Next Calibration date
TEST Receiver	ESCI7	ROHDE & SCHWARZ	100916	22-Oct-19
Logbicon Antenna	VULB 9168	SCHWARZBECK	193	15-Oct-19
Turn Table	DT3000-2t	Innco System GmbH	N/A	-
Antenna Mast	MA4000-EP	Innco System GmbH	N/A	-
Antenna Master & Turn table controller	CO2000-P	Innco System GmbH	CO2000/641 /28051111/L	-
Loop Antenna	HFH2-Z2	ROHDE & SCHWARZ	100188	30-Apr-19

5.3 Environmental Condition

Test Place : 10 m Semi-anechoic chamber
 Temperature (°C) : 23.2 °C
 Humidity (%) : 43.2 % R.H.



5.4 Test data (9 kHz ~ 30 MHz)

Test Date : 20-May-19

Measurement Distance : 3 m

Frequency (kHz)	Reading (dB μ V)	Vertical Position [Angle]	Height (m)	Correction Factor		Result Value(Qeas-Peak)		
				Ant Factor (dB)	Cable (dB)	Limit (dB μ V/m)	Result (dB μ V/m)	Margin (dB)
112.90	50.26	320 °	0.8	19.58	0.5	105.7	70.34	-35.33
Remark	<p>H : Horizontal, V : Vertical There did not measure any radiated spurious emission in the range 9 kHz to 30 MHz *There is no found Restricted bands. *The 300 m limit was converted to 3m Limit using square factor(x) as it was found by measurements as follows: 3 m Limit(dBuV/m) = 20log(2400/F(KHz))+40log(300/3)= 20log(2400/125)+40log(300/3)</p>							

5.4 Test data(30 MHz ~ 1 000 MHz)

Test Date : 20-May-19

Measurement Distance : 3 m

Frequency (MHz)	Reading (dB μ V)	Position (V/H)	Height (m)	Correction Factor		Result Value(Quasi-peak)		
				Ant Factor (dB)	Cable (dB)	Limit (dB μ V/m)	Result (dB μ V/m)	Margin (dB)
500.00	16.74	V	1.0	17.99	3.52	46.00	38.25	7.75
550.00	19.23	V	1.0	19.03	3.73	46.00	41.98	4.02
600.00	12.14	V	1.0	20.07	3.93	46.00	36.14	9.86
650.00	16.86	V	1.0	20.69	4.10	46.00	41.65	4.35
700.00	11.22	V	1.0	21.31	4.27	46.00	36.80	9.20
750.00	14.46	H	1.4	21.93	4.45	46.00	40.84	5.16
Remark	<p>H : Horizontal, V : Vertical *Result Value = Reading + Antenna + Cable loss *Correction Factor = Ant Factor + Cable *The resolution bandwidth and video bandwidth of test receiver/spectrum analyzer is 120 kHz for Quasi-peak detection</p>							

6. Measurement of conducted disturbance

The continuous disturbance voltage of AC Mains in the frequency from 0.15 MHz to 30 MHz was measured in accordance to FCC Part 15 & ANSI C 63.10 (2013) The test setup was made according to FCC Part 15 & ANSI C 63.10 (2013) in a shielded Room. The EUT was placed on a non-conductive table at least 0.8 m above the ground plan. A grounded vertical reference plane was positioned in a distance of 0.4 m from the EUT. The distance from the EUT to other metal surfaces was at least 0.8 m. The EUT was only earthen by its power cord through the line impedance stabilizing network. The power cord has been bundled to a length of 1.0 m. The test receiver with Quasi Peak detector complies with CISPR 16.

6.1 Measurement equipments

Equipment Name	Type	Manufacturer	Serial No.	Next Calibration date
TEST Receiver	ESHS 30	Rohde & Schwarz	828765/002	24-Oct-19
LISN	ESH2-Z5	Rohde & Schwarz	836679/025	24-Oct-19
Pulse Limiter	ESH3-Z2	Rohde & Schwarz	NONE	23-Oct-19

6.2 Environmental Condition

Test Place : Shielded Room
 Temperature (°C) : 23.1 °C
 Humidity (% R.H.) : 42.5 % R.H.

6.3 Test data

Test Date : 21-May-19

Frequency (MHz)	Correction Factor		Line (H/N)	Quasi-peak Value			Average Value		
	Lisn (dB)	Cable (dB)		Limit (dB μ V)	Reading (dB μ V)	Result (dB μ V)	Limit (dB μ V)	Reading (dB μ V)	Result (dB)
0.20	0.61	0.27	H	63.45	37.35	38.23	53.45	33.00	33.88
0.27	0.44	0.27	N	61.12	37.51	38.23	51.12	33.48	34.20
0.34	0.46	0.27	N	59.23	33.68	34.41	49.23	30.22	30.95
0.47	0.48	0.28	N	56.44	33.62	34.38	46.44	30.72	31.48
0.61	0.68	0.28	H	56.00	38.08	39.05	46.00	34.74	35.71
0.68	0.50	0.28	N	56.00	37.90	38.68	46.00	35.82	36.60
Remark	H : Hot Line, N : Neutral Line *Correction Factor = Lisn + Cable *Result = Correction Factor + Reading								

Appendix 1. Special diagram

*HOT LINE

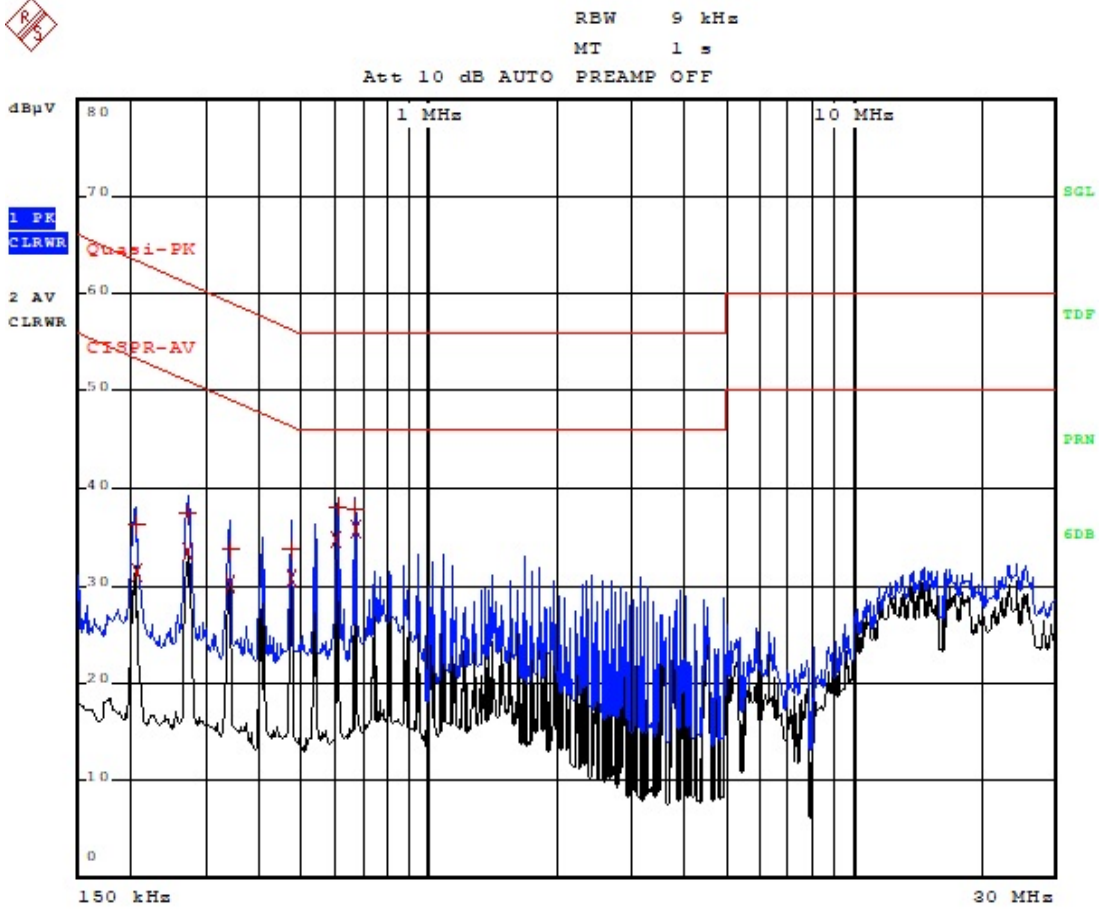

Comment: FL-DB_125k_HOT

*NEUTRAL LINE



RBW 9 kHz
MT 1 s

Att 10 dB AUTO PREAMP OFF

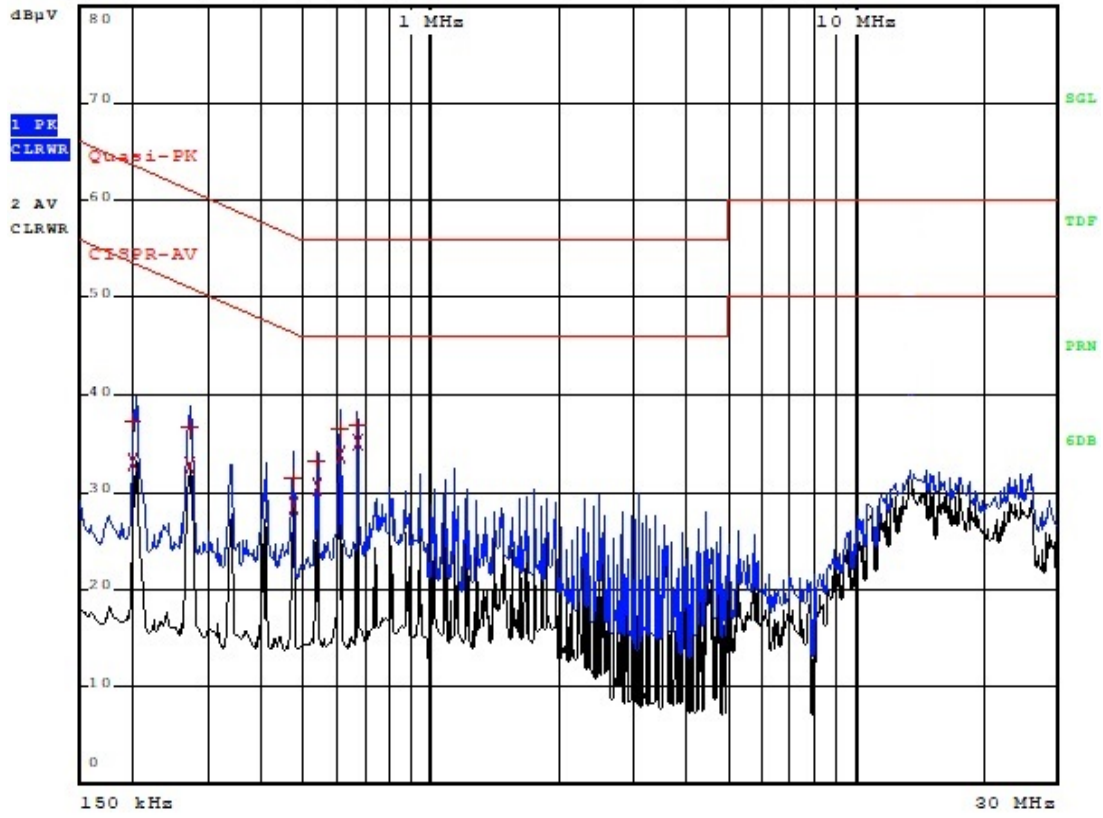

Comment: FL-DB_125k_NEUTRAL

Appendix 2. Antenna Requirement

Regulation

According to §15.203, an intentional radiator shall be designed to ensure that no antenna other than that furnished by the responsible party shall be used with the device. The use of a permanently attached antenna or of an antenna that uses a unique coupling to the intentional radiator shall be considered sufficient to comply with the provisions of this Section. The manufacturer may design the unit so that a broken antenna can be replaced by the user, but the use of a standard antenna jack or electrical connector is prohibited.

Result

-Complied

The transmitter has an integral Loop PCB antenna.