



	ESTECH Co., Ltd. Rm. 1015, World Venture Center II, 426-5 Gasan-dong, Guncheon-gu, Seoul, 158-803, Korea	    	Electromagnetic Interference Test Report

Test Report for FCC

FCC ID:TKWBIOSTATIONMFTC

Report Number		ESTF150803-011			
Applicant	Company name	Suprema Inc.			
	Address	16F Parkview Office Tower, Jeongja-dong, Bundang-gu, Seongnam, Gyeonggi, 463-863 Korea			
	Telephone	82-31-783-4505			
Product	Product name	FINGERPRINT SYSTEM			
	Model No.	BioStation Mifare TC (BSM-TC)	Manufacturer	Suprema Inc.	
	Serial No.	NONE	Country of origin	KOREA	
Test date	2008-03-02		Date of issue	20-Mar-08	
Testing location	ESTECH. Co., Ltd. 97-1 Hoiuk-Ri Majang-Myon, Icheon-city, KyungKi-Do, Korea				
Standard	FCC PART 15 2007 , ANSI C 63.4 2003				
Test item	Conducted Emission	Class A	Class B	Test result	OK
	Radiated Emission	Class A	Class B	Test result	OK
Measurement facility registration number		94696			
Tested by	Engineer J.H.Kim				
Reviewed by	Engineering Manager J.M.Yang				
Abbreviation	OK, Pass = Passed, Fail = Failed, N/A = not applicable				
<p>* Note</p> <ul style="list-style-type: none"> - This test report is not permitted to copy partly without our permission - This test result is dependent on only equipment to be used - This test result based on a single evaluation of one sample of the above mentioned 					

Contents

1. Laboratory Information	3
2. Description of EUT	4
3. Test Standards	5
4. Measurement condition	6
5. Measurement of radiated emission	8
5.1 Measurement equipment	8
5.2 Environmental conditions	8
5.3 Test data	9
6. Measurement of conducted emission	10
6.1 Measurement equipment	10
6.2 Environmental conditions	10
6.3 Test data	11
7. Photographs of test setup.....	12
7.1 Setup for Radiated Test : 30 ~ 2000 MHz.....	12
7.2 Setup for Conducted Test : 0.15 ~ 30 MHz.....	13
8. Photographs of EUT.....	14
8.1 Setup for Conducted Test : 0.15 ~ 30 MHz.....	15
 Appendix 1. Spectral diagram	
Appendix 2. Phorographs of EUT in side PCB	



1. Laboratory Information

1.1 General

This EUT (Equipment Under Test) has been shown to be capable of compliance with the applicable technical standards and is tested in accordance with the measurement procedures as indicated in this report.

ESTECH Lab attests to accuracy of test data. All measurement reported herein were performed by ESTECH Co., Ltd.

ESTECH Lab assume full responsibility for the completeness of these measurements and vouch for the qualifications of all persons taking them.

1.2 Test Lab.

Corporation Name : ESTECH Co. Ltd

Head Office : Rm 1015, World Venture Center II, 426-5, Gasan-dong, Geumcheon-gu, Seoul, Korea
(Safety & Telecom. Test Lab)

EMC Test Lab : 58-1 Osan-Ri, GaNam-Myon, YeoJoo-Gun, KyungKi-Do, Korea
97-1 Hoiuk-Ri Majang-Myon, Icheon-city, KyungKi-Do, Korea

1.3 Official Qualification(s)

MIC : Granted Accreditation from Ministry of Information & Communication for EMC, Safety and Telecommunication

KOLAS : Accredited Lab By Korea Laboratory Accreditation Schema base on CENELEC requirements

FCC : Filed Laboratory at Federal Communications Commission

VCCI : Granted Accreditation from Voluntary Control Council for Interference from ITE



2. Description of EUT

2.1 Summary of Equipment Under Test

Product Name : FINGERPRINT SYSTEM
 Model Number : BioStation Mifare TC (BSM-TC)
 Serial Number : NONE
 Manufacturer : Suprema Inc.
 Country of origin : KOREA
 Rating : AC input 100 ~ 240 VAC, 1.0A, 50/60Hz, DC output 12V - - 2.5A
 Receipt Date : 21 - Feb - 08
 X-tal lists : 12MHz, 27.12MHz, 20MHz

2.2 General descriptions of EUT

CPU : Dual CPU (32 bit RISC + 400MHz DSP)
Memory : 72MB flash + 34MB RAM
Display : 2.5 inch QVGA 16 million color LCD
Identification speed : 3,000 fingerprints in 1 second
Fingerprint capacity : 50,000 fingerprint templates
Log capacity : 500,000 events
Host interface : Wireless LAN (optional), TCP/IP, RS485
PC interface : USB, RS232
USB memory slot : USB host
1 relay for deadbolt, EM lock, door strike, or automatic door
Wiegand input/output, 4 TTL input/output
Built-in microphone and speaker supporting door phone
Convenient menu navigation key
4 function keys for user defined functions
Operation mode : Fingerprint, PIN, PIN+Fingerprint,
Card only*, Card+Fingerprint*, Card+PIN* (*RF model only)
RF Card : 125KHz proximity (EM, HID model only), 13.56MHz Mifare(Mifare model only)
RTC with backup battery (CR2032)**
Product size : 135 x 128 x 50 mm (width x length x depth)



3. Test Standards

Test Standard : FCC PART 15 (2007)

This Standard sets out the regulations under which an intentional, unintentional, or incidental radiator may be operated without an individual license. It also contains the technical specifications, administrative requirements and other conditions relating to the marketing of Part 15 devices.

Test Method : ANSI C 63.4 (2003)

This standard sets forth uniform methods of measurement of radio-frequency (RF) signals and noise emitted from both unintentional and intentional emitters of RF energy in the frequency range 9 kHz to 40 GHz. Methods for the measurement of radiated and AC power-line conducted radio noise are covered and may be applied to any such equipment unless otherwise specified by individual equipment requirements. These methods cover measurement of certain devices that deliberately radiate energy, such as intentional emitters, but does not cover licensed transmitters. This standard is not intended for certification/approval of avionic equipment or for industrial, scientific, and medical (ISM) equipment. These methods apply to the measurement of individual units or systems comprised of multiple units.

4. Measurement Condition

4.1 EUT Operation.

1. Check to normal mode operation
2. The operational conditions of the EUT was determined by the manufacturer according to the typical use of the EUT with respect to the expected highest level of emission.
3. Connect fingerprint system to Note PC, Local Lan and relay board.
4. Put hand to pingerprint system and check action availability from Note PC.
5. Check fingerprint system under continuous sending and receiving packet data between external network.

4.2 Configuration and Peripherals

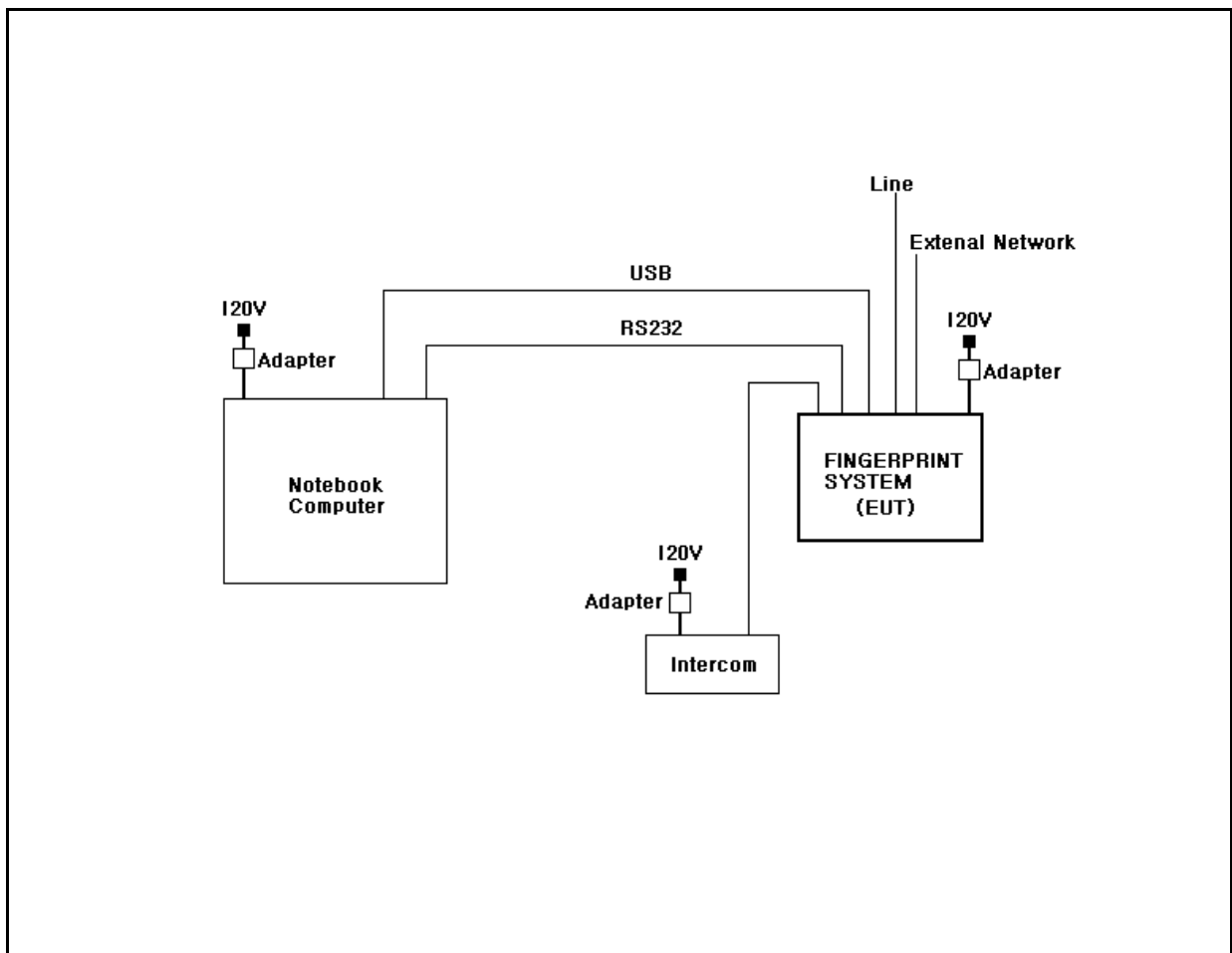

4.3 EUT and Support equipment

Equipment Name	Model Name	S/N	Manufacturer	Remark (FCC ID)
FINGERPRINT SYSTEM	BioStation Mifare TC (BSM-TC)	NONE	Suprema Inc.	EUT
Notebook Computer	D400	NONE	Dell Asia Pacific Sdn.	
Intercom	TP-nAc	NONE	COMMAX	
RS232 to RS485	TCC-80	azwhc1900053	Moxa Technologies Co.,Ltd.	
Adapter	PW127	KA1202N57	AULT Korea Corp.	
Adapter	JPW128	NONE	AULT Korea Corp.	
Adapter	DA-1650-05D	NONE	Lite-on Electronics Inc.	

4.4 Cable Connecting

Start Equipment		End Equipment		Cable Standard		Remark
Name	I/O port	Name	I/O port	Length	Shielded	
FINGERPRINT SYSTEM	USB	Notebook Computer	USB	2	Yes	
FINGERPRINT SYSTEM	LAN	External Network	LAN	20	No	
FINGERPRINT SYSTEM	LINE	Intercom	LINE	3	Yes	
FINGERPRINT SYSTEM	RS-232	Notebook Computer	RS-232	2	Yes	
FINGERPRINT SYSTEM	LINE (RS485,Wiegand)	-	-	3	Yes	
INTERFACE BAORD	Power	Adapter	-	2	No	
Notebook Computer	Power	Adapter	-	2	No	
INTERCOM	Power	Adapter	-	0.5	No	

5. Measurement of radiated disturbance

Above 30 MHz Electric Field strength was measured in accordance with FCC Part 15 (2007) & ANSI C 63.4 (2003). The test setup was made according to FCC Part 15 (2007) & ANSI C 63.4 (2003) on an open test site, which allows a 3m distance measurement. The EUT was placed in the center of wooden turntable. The height of this table was 0.8m. The measurement was conducted with both horizontal and vertical antenna polarization. The turntable has fully rotated. For further description of the configuration refer to the picture of the test setup.

5.1 Measurement equipments

Equipment Name	Type	Manufacturer	Serial No.	Next Calibration date
TEST Receiver	ESVS10	Rohde & Schwarz	838562/002	2009. 1. 24
Spectrum Analyzer	R3261C	ADVANTEST	61720116	2008. 4. 20
LogBicon Antenna	VULB 9160	Schwarzbeck	3142	2008. 5. 07
Amplifier	8447F	HP	2805A02972	2008. 6. 26
Turn Table	2087	EMCO	2129	-
Antenna Mast	2070-01	EMCO	9702-203	-
ANT Mast Controller	2090	EMCO	1535	-
Turn Table Controller	2090	EMCO	1535	-

5.2 Environmental Condition

Test Place : Open site(3m)
 Temperature (°C) : 15
 Humidity (%) : 38 %

5.3 Test data

Test Date : 2-Mar-08

Measurement Distance : 3 m

Frequency (MHz)	Reading (dB μ V)	Position (V/H)	Height (m)	Correction Factor		Result Value		
				Ant Factor (dB)	Cable (dB)	Limit (dB μ V/m)	Result (dB μ V/m)	Margin (dB)
50.00	11.10	V	1.0	12.55	0.7	40.0	24.35	-15.65
77.79	13.60	H	4.0	8.40	0.9	40.0	22.85	-17.15
86.14	17.00	H	4.0	7.99	1.0	40.0	25.96	-14.04
111.12	12.40	H	4.0	10.36	1.3	43.5	24.07	-19.43
162.58	14.10	H	1.9	12.68	1.7	43.5	28.51	-14.99
190.00	10.50	H	1.8	10.44	2.0	43.5	22.94	-20.56
224.20	12.00	H	1.5	10.53	2.3	46.0	24.88	-21.12
258.63	17.00	H	1.0	11.79	2.6	46.0	31.38	-14.62
293.75	12.70	H	1.0	12.91	2.9	46.0	28.55	-17.45
351.99	14.40	V	1.3	14.27	3.4	46.0	32.03	-13.97
400.21	13.90	H	1.0	15.32	3.7	46.0	32.92	-13.08
466.74	16.00	V	1.3	16.85	4.1	46.0	36.95	-9.05
500.00	10.00	V	1.0	17.18	4.4	46.0	31.58	-14.42
600.09	11.60	H	1.0	19.69	5.0	46.0	36.29	-9.71
666.73	13.10	V	1.2	20.29	5.4	46.0	38.83	-7.17
750.02	7.50	V	1.7	21.86	5.9	46.0	35.21	-10.79
899.89	6.10	H	1.4	23.21	6.5	46.0	35.81	-10.19
Remark	H : Horizontal, V : Vertical *There is no detected Radiated Emission above 1GHz *CL = Cable Loss-Amplifier Gain(In case of above1000Mhz) *CL = Cable Loss(In case of below1000Mhz) *The resolution bandwidth and video bandwidth of test receiver/spectrum analyzer is 120KHz for Quasi-peak detection at frequency below 1GHz.							

6. Measurement of conducted disturbance

The continuous disturbance voltage of AC Mains in the frequency from 0.15 to 30 MHz was measured in accordance to FCC Part 15 (2007) & ANSI C 63.4 (2003) The test setup was made according to FCC Part 15 (2007) & ANSI C 63.4 (2003) in a shielded Room. The EUT was placed on a non-conductive table at least 80 above the ground plan. A grounded vertical reference plane was positioned in a distance of 40cm from the EUT. The distance from the EUT to other metal surfaces was at least 0.8m. The EUT was only earthen by its power cord through the line impedance stabilizing network. The power cord has been bundled to a length of 1.0m.. The test receiver with Quasi Peak detector complies with CISPR 16.

6.1 Measurement equipments

Equipment Name	Type	Manufacturer	Serial No.	Next Calibration date
LISN	ESH3-Z5	Schwarzbeck	838979/010	2009. 2. 29
LISN	NNLA8120A	Schwarzbeck	8120161	2009. 2. 29
TEST Receiver	ESPI7	Rohde & Schwarz	100185	2008. 8. 27
Pulse Limiter	ESH3Z2	Rohde & Schwarz	NONE	-

6.2 Environmental Condition

Test Place : Shielded Room
 Temperature (°C) : 19
 Humidity (%) : 33 %

6.3 Test data

Test Date : 2-Mar-08

Frequency (MHz)	Correction Factor		Line (H/N)	Quasi-peak Value			Average Value		
	Lish (dB)	Cable (dB)		Limit (dB μ V)	Reading (dB μ V)	Result (dB μ V)	Limit (dB μ V)	Reading (dB μ V)	Result (dB)
0.16	0.15	0.8	N	65.57	31.21	32.12	55.57	25.97	26.88
0.20	0.17	0.8	N	63.65	45.34	46.30	53.65	33.06	34.02
0.27	0.20	0.8	N	61.27	39.24	40.29	51.27	27.58	28.63
0.33	0.21	0.9	N	59.43	33.11	34.18	49.43	23.86	24.93
0.40	0.21	0.8	H	57.92	29.17	30.21	47.92	22.08	23.12
0.46	0.20	0.8	H	56.62	28.12	29.12	46.62	23.70	24.70
0.59	0.20	0.8	N	56.00	33.60	34.59	46.00	30.92	31.91
0.60	0.20	0.8	H	56.00	32.74	33.73	46.00	30.71	31.70
0.66	0.20	0.8	N	56.00	33.19	34.19	46.00	29.85	30.85
2.89	0.26	0.9	N	56.00	34.63	35.77	46.00	34.29	35.43
4.56	0.32	0.9	H	56.00	32.57	33.83	46.00	28.59	29.85
4.62	0.32	0.9	N	56.00	33.22	34.48	46.00	29.56	30.82
7.46	0.48	1.1	N	60.00	39.04	40.66	50.00	35.97	37.59
8.78	0.49	1.3	H	60.00	40.78	42.53	50.00	37.70	39.45
8.98	0.49	1.3	N	60.00	41.76	43.53	50.00	38.20	39.97
9.57	0.50	1.3	N	60.00	41.47	43.31	50.00	38.17	40.01
9.64	0.50	1.3	H	60.00	40.76	42.60	50.00	34.13	35.97
10.43	0.52	1.4	N	60.00	39.64	41.53	50.00	36.71	38.60
Remark	H : Hot Line, N : Neutral Line								

7. Photographs of test setup

7.1 Setup for Radiated Test : 30 ~ 2000 MHz

[Front]



[Rear]



7.2 Setup for Conducted Test : 0.15 ~ 30 MHz

[Front]



[Rear]



8. Photographs of EUT

[Front]



[Rear]



8.1 Photographs of EUT

[Front]



[Rear]



Appendix 1. Spectral diagram

*HOT



RBW 9 kHz
MT 1 s

Att 10 dB AUTO PREAMP OFF

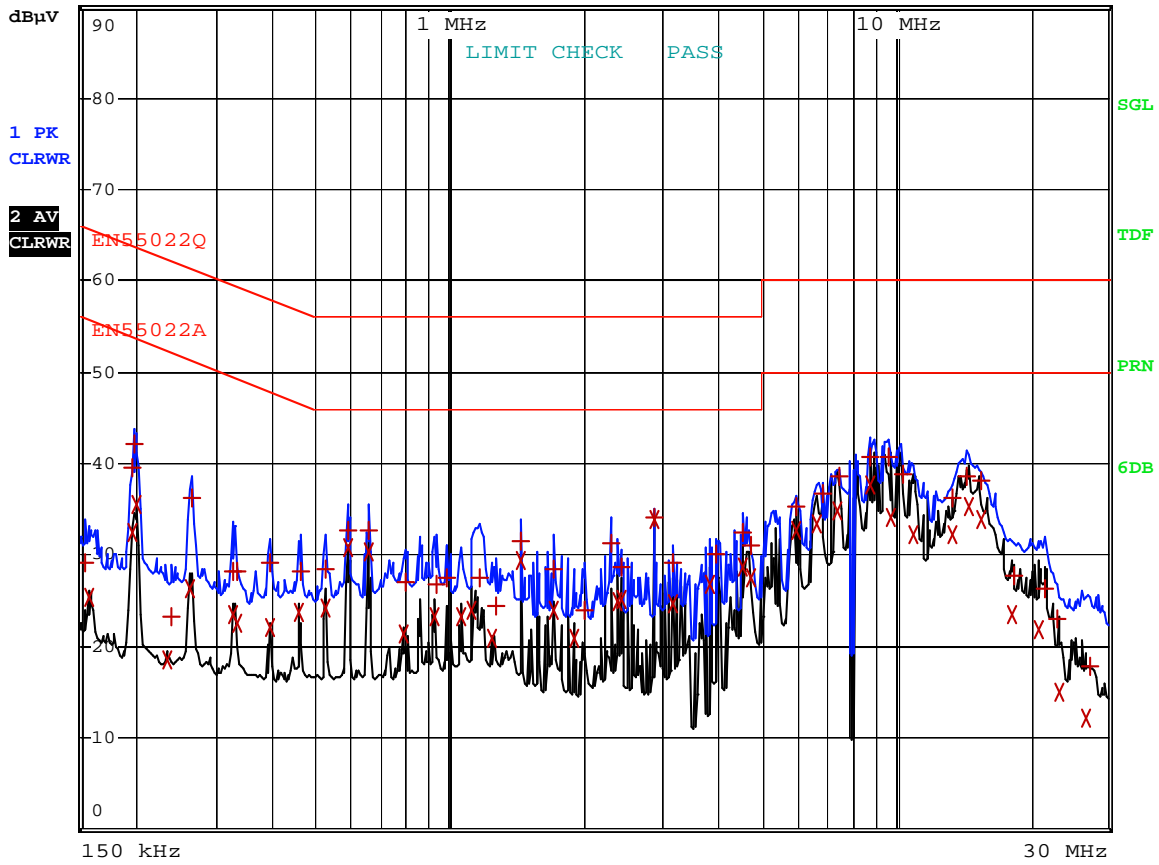

Comment: BioStation BSM-TC_HOT
Date: 2.MAR.2008 08:10:51

*NEUTRAL



RBW 9 kHz
MT 1 s

Att 10 dB AUTO PREAMP OFF

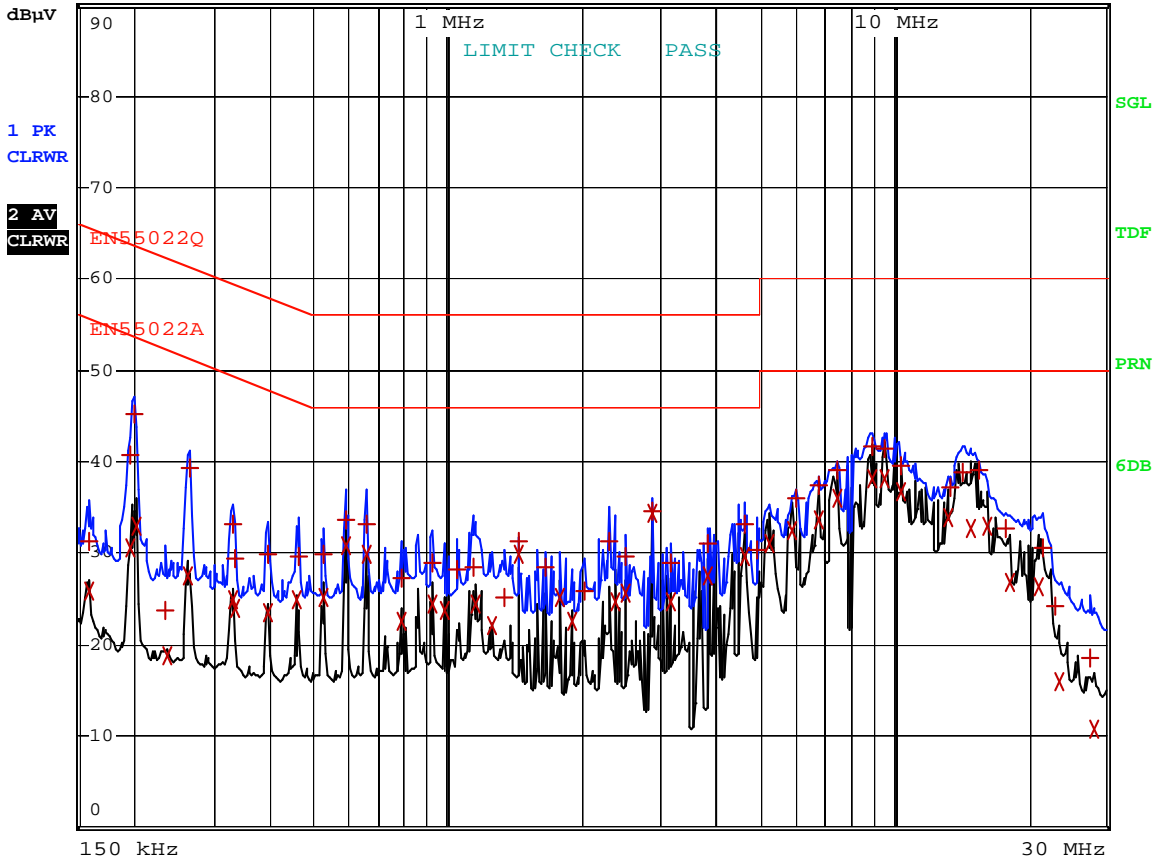

Comment: BioStation BSM-TC_NEUTRAL
Date: 2.MAR.2008 08:15:46

Appendix 2. Photographs of EUT in side PCB

