

## Test Report for FCC

FCC ID : TKWBEWIOC

Report Number		ESTF151303-004			
Applicant	Company name	Suprema Inc.			
	Address	16F Parkview Tower, Jeongja-dong, Bundang-gu, Seongnam, Gyeonggi, 463-863 Korea			
	Telephone	+82-31-710-2494			
Product	Product name	BioEntry W			
	Model No.	BEWI-OC	Manufacturer	Suprema Inc.	
	Serial No.	NONE	Country of origin	KOREA	
Test date	28-Feb-13		Date of issue	14-Mar-13	
Testing location	ESTECH Co., Ltd. 97-1 Hoiuk-Ri Majang-Myon, Icheon-Si, KyungKi-Do, Korea				
Standard	FCC PART 15 (2010) , ANSI C 63.4 2003				
Test item	<input checked="" type="checkbox"/> Conducted Emission	<input type="checkbox"/> Class A	<input checked="" type="checkbox"/> Class B	Test result	OK
	<input checked="" type="checkbox"/> Radiated Emission	<input type="checkbox"/> Class A	<input checked="" type="checkbox"/> Class B	Test result	OK
Measurement facility registration number		915135			
Tested by	Engineer S.B.Lee <span style="float: right;">(Signature)</span>				
Reviewed by	Engineering Manager J.M.Yang <span style="float: right;">(Signature)</span>				
Abbreviation	OK, Pass = Complied, Fail = Failed, N/A = not applicable				
<p>* Note</p> <ul style="list-style-type: none"> <li>- This test report is not permitted to copy partly without our permission</li> <li>- This test result is dependent on only equipment to be used</li> <li>- This test result based on a single evaluation of one sample of the above mentioned</li> </ul>					

## Contents

1.	Laboratory Information .....	3
2.	Description of EUT .....	4
3.	Test Standards .....	5
4.	Measurement condition .....	6
5.	20dBm Bandwidth .....	8
5.1	Procedure .....	8
5.2	20dBm Bandwidth Set up .....	8
5.3	Measurement Data .....	8
6.	Frequency Tolerance .....	9
6.1	Procedure .....	9
6.2	Test Equipments .....	9
6.3	Measurement Data .....	10
7.	Measurement of radiated emission .....	11
7.1	Radiated emission limits, general requirements .....	11
7.2	Measurement equipment .....	11
7.3	Environmental conditions .....	11
7.4	Test data(9 kHz ~30 MHz) .....	12
7.5	Test data(30 MHz ~ 1 GHz) .....	13
7.6	Test data(Above 1 GHz) .....	13
8.	Measurement of conducted emission .....	14
8.1	Measurement equipment .....	14
8.2	Environmental conditions .....	14
8.3	Test data .....	14
9.	Photographs of test setup .....	16
10.	Photographs of EUT .....	18

Appendix 1. Special diagram

Appendix 2. Antenna Requirement



## 1. Laboratory Information

### 1.1 General

This EUT (Equipment Under Test) has been shown to be capable of compliance with the applicable technical standards and is tested in accordance with the measurement procedures as indicated in this report. ESTECH Lab attests to accuracy of test data. All measurement reported herein were performed by ESTECH Co., Ltd.

ESTECH Lab assume full responsibility for the completeness of these measurements and vouch for the qualifications of all persons taking them.

### 1.2 Test Lab.

Corporation Name : ESTECH Co., Ltd.

Head Office : Rm 1015, World Venture Center II, 426-5, Gasan-dong, Geumcheon-gu, Seoul, Korea  
(Safety & Telecom. Test Lab)

EMC Test Lab : 97-1 Hoiuk-Ri Majang-Myon, Icheon-city, KyungKi-Do, Korea

### 1.3 Official Qualification(s)

KCC : Granted Accreditation from Ministry of Information & Communication for EMC, Safety and Telecommunication

KOLAS : Accredited Lab By Korea Laboratory Accreditation Schema base on CENELEC

FCC : Filed Laboratory at Federal Communications Commission

VCCI : Granted Accreditation from Voluntary Control Council for Interference from ITE

## 2. Description of EUT

### 2.1 Summary of Equipment Under Test

Product : BioEntry W  
 Model Number : BEWI-OC  
 Serial Number : NONE  
 Manufacturer : Suprema Inc.  
 Country of origin : KOREA  
 Operating Frequency : 13.56 MHz  
 Antenna Type : PCB Pattern Antenna  
 Modulation Type : ASK  
 Channel Spacing : 1

Power Rating : INPUT : (100 – 240) Va.c., (50 – 60) Hz, 1.0 A  
 : OUTPUT : 12 Vd.c., 2.5 A  
 : PoE : Power over Ethernet

Receipt Date : 14-Feb-13

X-tal list(s) or Frequencies generated : The highest operating frequency is 533 MHz in the CPU.

### 2.2 General descriptions of EUT

<b>System</b>	<b>Max Users</b>		5000 users (10,000 templates) [1:1 & 1:N]
	<b>Log Capacity</b>		50,000 logs
	<b>CPU</b>		533MHz DSP
	<b>Memory</b>		8MB Flash + 8MB RAM
	<b>RF Options</b>		13.56MHz iClass
	<b>Interfaces</b>		TCP/IP, RS485, Wiegand
	<b>Input / Output</b>		2 TTL Inputs, 1 Relay Output
	<b>Power</b>		12VDC, PoE (Power over Ethernet)
<b>General</b>	<b>Dimensions</b>	<b>BioEntry W (W x H x D)</b>	50 x 172 x 44 mm
		<b>Wall Bracket (W x H)</b>	40 x 157 mm (screw joint included)

### 3. Test Standards

#### Test Standard : FCC PART 15 (2010)

This Standard sets out the regulations under which an intentional, unintentional, or incidental radiator may be operated without an individual license. It also contains the technical specifications, administrative requirements and other conditions relating to the marketing of Part 15 devices.

#### Test Method : ANSI C 63.4 (2003)

This standard sets forth uniform methods of measurement of radio-frequency (RF) signals and noise emitted from both unintentional and intentional emitters of RF energy in the frequency range 9 kHz to 40 GHz. Methods for the measurement of radiated and AC power-line conducted radio noise are covered and may be applied to any such equipment unless otherwise specified by individual equipment requirements. These methods cover measurement of certain devices that deliberately radiate energy, such as intentional emitters, but does not cover licensed transmitters. This standard is not intended for certification/approval of avionic equipment or for industrial, scientific, and medical (ISM) equipment. These methods apply to the measurement of individual units or systems comprised of multiple units.

#### Summary of Test Results

Applied Standard : 47 CFR Part 15, Subpart C				
Standard	Test Type	Result	Remark	Limit
15.207	AC Power Conducted Emission	Pass	Meet the requirement	
15.225(a)	Radiated Emission (13.553 ~13.567) MHz	Pass	Meet the requirement	15,848 uV/m at 30 m
15.225(b)	Radiated Emission (13.410 ~13.553 , 13.567 ~ 13.710) MHz	Pass	Meet the requirement	334 uV/m at 30 m
15.225(c)	Radiated Emission (13.110 ~13.410 , 13.710 ~ 14.010) MHz	Pass	Meet the requirement	106 uV/m at 30 m
15.225(d)	Apply section 15.209 (out side band of the 13.110 ~14.010) MHz	Pass	Meet the requirement	
15.225(e)	Frequency stability	Pass	Meet the requirement	
15.215(c)	20dB Bandwidth	Pass	Meet the requirement	



**ESTECH Co., Ltd.**

Rm 1015, World Venture Center II,  
426-5 Gasan-dong, Guncheon-gu,  
Seoul. 158-803, Korea



**Electromagnetic  
Interference  
Test Report**

## 4. Measurement Condition

### 4.1 EUT Operation.

- The EUT was in the following operation mode during all testing
  1. EUT Configuration and Peripherals such as connection settings
  2. 13.56 MHz RF Signal Transmit / Receive the best action status to the test.

### 4.2 Configuration and Peripherals

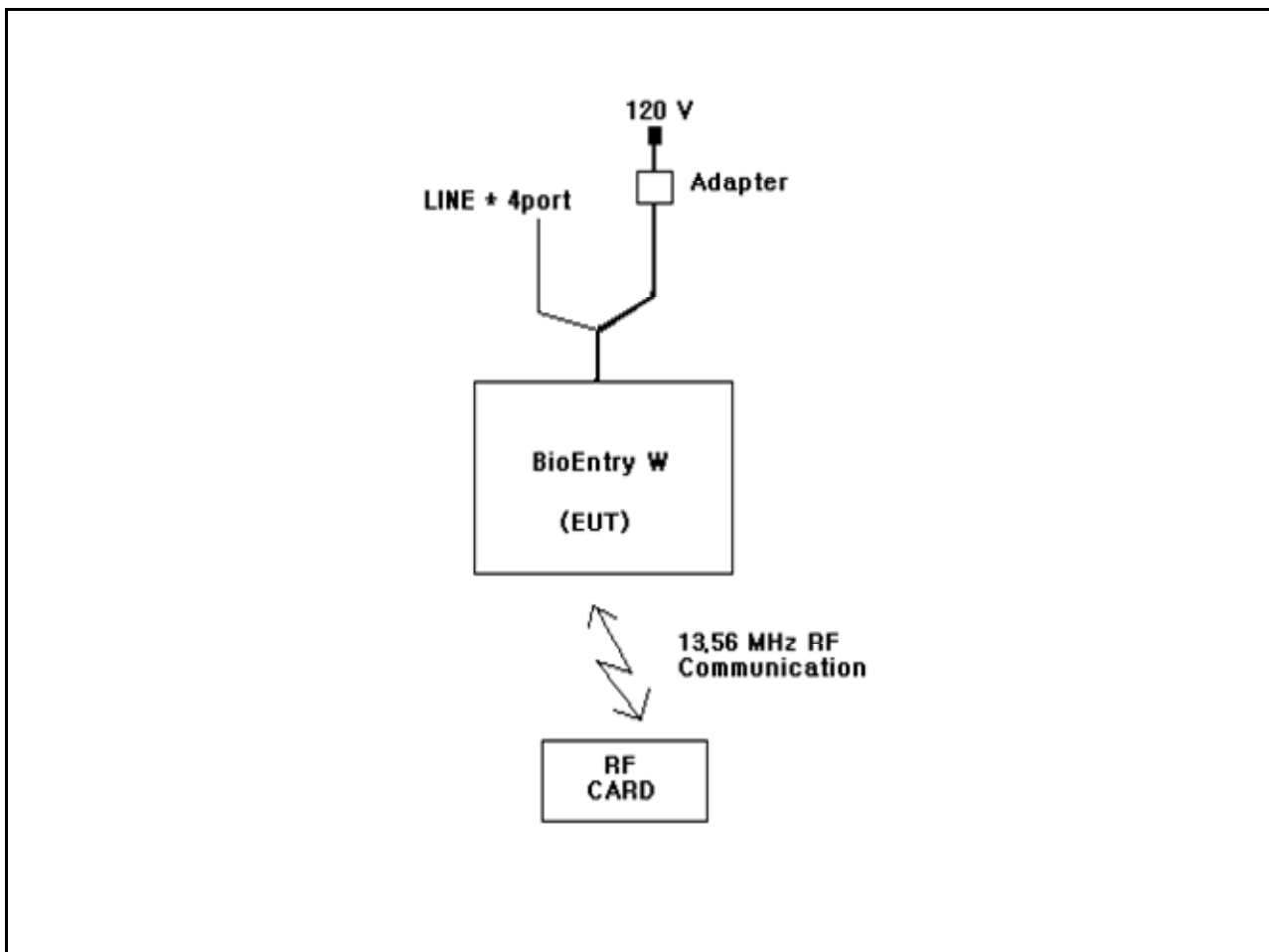

### 4.3 EUT and Support equipment

Equipment Name	Model Name	S/N	Manufacturer	Remark (FCC ID)
BioEntry W	BEWI-OC	NONE	Suprema Inc.	EUT
Adapter	JPW128KA1200N05	NONE	I.T.E POWER SUPPLY	
RF CARD	NONE	NONE	NONE	

### 4.4 Cable Connecting

Start Equipment		End Equipment		Cable Standard		Remark
Name	I/O port	Name	I/O port	Length	Shielded	
BioEntry W	POWER	Adapter	-	2	Unshielded	
BioEntry W	13.56 MHz RF Signal	RF CARD	13.56 MHz RF Signal	-	-	
BioEntry W	LINE(RS-485)	-	-	3	Unshielded	
BioEntry W	LINE(Switch)	-	-	3	Unshielded	
BioEntry W	LINE(Wiegand)	-	-	3	Unshielded	
BioEntry W	LINE(Relay)	-	-	3	Unshielded	

## 5. 20 dB Bandwidth

### 5.1 Procedure

The measurement was performed in the antenna height to gain the maximum of Electric field strength

### 5.2 20dB Bandwidth setup

The spectrum analyzer is set to as following

RBW: 30 Hz

VBW: 300 Hz

Span: 5 kHz

Sweep:suitable duration based on the EUT specification

#### 20dB Bandwidth Test Instruments

Decription	Model	Serial Number	Cal. Due Data
Spectrum Analyzer	E4407B	US40241281	27-Jan-14

### 5.3 Measurement Data

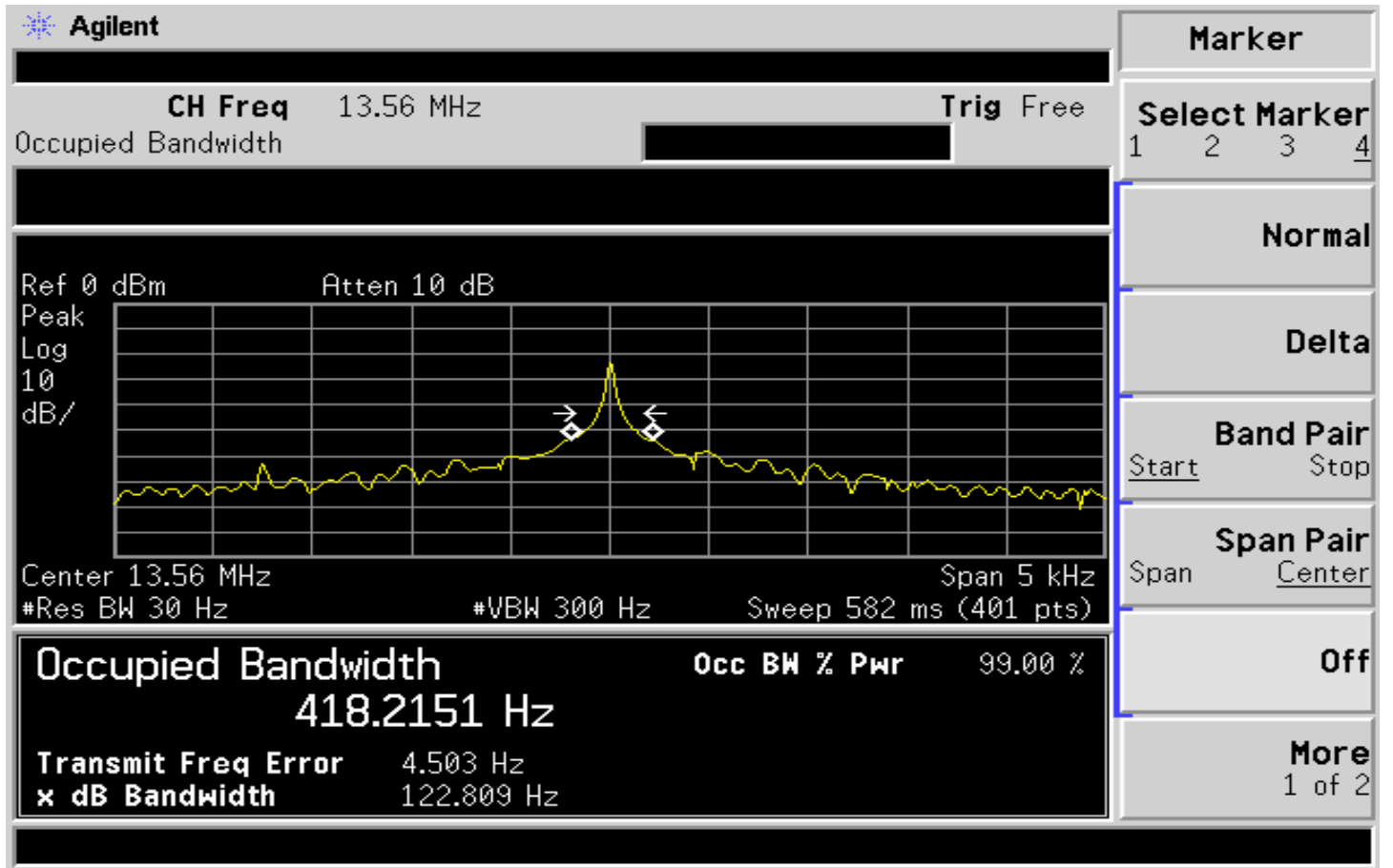



## 6. Frequency Tolerance

### 6.1 Procedure

The frequency stability of the transmitter is measured by:

- a) Temperature: The temperature is varied from  $-20\text{ }^{\circ}\text{C}$  to  $+50\text{ }^{\circ}\text{C}$  using an environmental chamber.
- b) Primary Supply Voltage: The primary supply voltage is varied from 85 % to 115 % of the voltage normally at the input to the device or at the power supply terminals if cables are not normally supplied.

The frequency tolerance of the carrier shall be maintained within  $\pm 0.01\%$  of the operating frequency.

### 6.2 Equipment lists

The following test equipments are used during test

Decription	Model	Serial Number	Cal. Due Data
Spectrum Analyzer	E4407B	US40241281	27-Jan-14
DC Power Supply	AK-5007	00230804	31-Jan-14
Temp./Humidity Chamber	TEMP-HUMI-S-1500	112192724	20-Jun-13

### 6.3 Measurement Data

Operating Frequency :	13,560,000 Hz
Reference Voltage :	12.00 Vd.c.
Deviation Limit :	± 0.01 %

Voltage (%)	Power (Vdc)	Temperature (°C)	Frequency (Hz)	Deviation (%)
100	12.00	+20 °C (Ref)	13,560,124	0.000914
100		-20	13,560,127	0.000937
100		-10	13,560,120	0.000885
100		<b>0</b>	13,560,119	0.000878
100		10	13,560,125	0.000922
100		20	13,560,122	0.000900
100		25	13,560,121	0.000892
100		30	13,560,123	0.000907
100		40	13,560,115	0.000848
100		50	13,560,123	0.000907
85		10.2	20	13,560,130
115	13.8	20	13,560,135	0.000996

## 7. Measurement of radiated disturbance

The EUT was placed on the top of a rotating table 0.8 m above the ground at a 3 m Open test site. The table was rotated 360° to determine the position of the highest radiation. Then antenna is a loop antenna is fixed at 1 m above the ground to determine the maximum value of the field strength. Both parallel and perpendicular of the antenna are set to make the measurement. For each suspected emission, the EUT was arranged to its worst case and then the table was turned from 0° to 360° to find the maximum reading. The test receiver system was set to Peak Detect Function and Specified Bandwidth with Maximum Hold Mode.

### 7.1 Radiated emission limits, general requirements

Except as provided elsewhere in this Subpart, the emissions from an intentional radiator shall not exceed the field strength levels specified in the following table:

Frequency (MHz)	Field strength @30 m (uV/m)	Field strength @30 m (dBuV/m)	Field strength @3m (dBuV/m)
Below 13.110	30	29.5	69.5
13.110 ~13.410	106	40.5	80.5
13.410~13.553	334	50.5	90.5
13.553~13.567	15,848	84	124
13.567~13.710	334	50.5	90.5
13.710~14.010	106	40.5	80.5
Above 14.010	30	29.5	69.5

\* dBuV/m=20\*log(uV/m)   \* Distance factor=40dB / decade(15.31(f))

### 7.2 Measurement equipments

Equipment Name	Type	Manufacturer	Serial No.	Next Calibration date
TEST Receiver	ESCI7	ROHDE & SCHWARZ	1166.5950.07	25-Jan-14
Logbicon Antenna	VULB 9168	SCHWARZBECK	9168-193	22-May-13
Turn Table	DT3000-2t	Innco System GmbH	N/A	-
Antenna Mast	MA4000-EP	Innco System GmbH	N/A	-
Antenna Master & Turn table controller	CO2000-P	Innco System GmbH	CO2000/641 /28051111/L	-
Loop Antenna	HFH2-Z2	ROHDE & SCHWARZ	100188	27-Jul-13

### 7.3 Environmental Condition

Test Place : 10 m Semi-anechoic chamber

#### Below 1 GHz

Temperature (°C) : 23.1 °C

Humidity (% R.H.) : 52.5 % R.H.

Test Place : 3 m Semi-anechoic chamber(3 m)

#### Above 1 GHz

Temperature (°C)

Humidity (% R.H.)

### 7.4 Test data(9 kHz ~ 30 MHz)

Test Date : 28-Feb-13

Measurement Distance : 3 m

Frequency (MHz)	Reading (dB $\mu$ V)	Vertical Position [Angle]	Height (m)	Correction Factor		Result Value(Quasi-Peak)		
				Ant Factor	Cable (dB)	Limit (dB $\mu$ V/m)	Result (dB $\mu$ V/m)	Margin (dB)
Below 13.110 MHz								
Noise Floor	-	-	-	18.70	0.5	69.5	-	-
13.110 MHz to 13.410 MHz								
Noise Floor	-	-	-	18.70	0.5	80.5	-	-
13.410 MHz to 13.553 MHz								
Noise Floor	-	-	-	18.70	0.5	90.5	-	-
13.553 MHz to 13.567 MHz								
13.560	46.00	92.0 °	1.0	18.70	0.5	124.0	65.20	58.80
13.567 MHz to 13.710 MHz								
Noise Floor	-	-	-	18.70	0.5	90.5	-	-
13.710 MHz to 14.010 MHz								
Noise Floor	-	-	-	18.70	0.5	80.5	-	-
14.010 MHz to 30 MHz								
27.00	16.20	95.0 °	1.0	18.80	0.8	69.5	35.80	33.70
Remark	<p>*There was no detected Restricted bands and Radiated suprious emission below 30 MHz.</p> <p>*The 30 m limit was converted to 3 m Limit using square factor(x) as it was found by measurements as follows;</p> <p>*3 m Limit(dBuV/m) = 20log(X)+40log(30/3)= 20log(15848)+40log(30/3) = 124 dBuV</p> <p>*3 m Limit(dBuV/m) = 20log(X)+40log(30/3)= 20log(30)+40log(30/3) = 69.5 dBuV</p> <p><b>* We tested for the worst case by rotating of antenna angle.</b></p>							



**ESTECH Co., Ltd.**

Rm 1015, World Venture Center II,  
426-5 Gasan-dong, Guncheon-gu,  
Seoul, 158-803, Korea



**Electromagnetic  
Interference  
Test Report**

### 7.5 Test data(30 MHz ~ 1 000 MHz)

Test Date : 28-Feb-13

Measurement Distance : 3 m

Frequency (MHz)	Reading (dB $\mu$ V)	Position (V/H)	Height (m)	Correction Factor		Result Value(Quasi-peak)		
				Ant Factor (dB)	Cable (dB)	Limit (dB $\mu$ V/m)	Result (dB $\mu$ V/m)	Margin (dB)
67.80	21.80	V	1.0	12.22	1.38	40.00	35.40	4.60
81.40	19.07	H	4.0	10.12	1.51	40.00	30.70	9.30
108.50	20.03	V	1.0	9.83	1.74	43.50	31.60	11.90
122.00	18.51	V	1.0	10.99	1.81	43.50	31.30	12.20
165.40	20.30	V	1.0	13.14	2.05	43.50	35.50	8.00
298.30	22.77	H	1.6	13.74	2.69	46.00	39.20	6.80
458.40	14.33	H	1.3	17.14	3.33	46.00	34.80	11.20
491.70	14.41	V	1.0	17.82	3.47	46.00	35.70	10.30
641.70	15.36	V	1.0	20.47	3.97	46.00	39.80	6.20
897.00	7.66	H	1.0	23.84	4.69	46.00	36.20	9.80
Remark	<p>H : Horizontal, V : Vertical            *Result Value = Reading + Antenna + Cable loss            *Correction Factor = Ant Factor + Cable            *The resolution bandwidth and video bandwidth of test receiver/spectrum analyzer is 120 kHz for Quasi-peak detection</p>							



## 8. Measurement of conducted disturbance

The continuous disturbance voltage of AC Mains in the frequency from 0.15 MHz to 30 MHz was measured in accordance to FCC Part 15 (2010) & ANSI C 63.4 (2003) The test setup was made according to FCC Part 15 (2010) & ANSI C 63.4 (2003) in a shielded Room. The EUT was placed on a non-conductive table at least 0.8 m above the ground plan. A grounded vertical reference plane was positioned in a distance of 0.4 m from the EUT. The distance from the EUT to other metal surfaces was at least 0.8 m. The EUT was only earthen by its power cord through the line impedance stabilizing network. The power cord has been bundled to a length of 1.0 m. The test receiver with Quasi Peak detector complies with CISPR 16.

### 8.1 Measurement equipments

Equipment Name	Type	Manufacturer	Serial No.	Next Calibration date
TEST Receiver	ESHS 30	Rohde & Schwarz	828765/002	25-Jan-14
LISN	ESH3-Z5	Rohde & Schwarz	838979/010	25-Jan-14
Pulse Limiter	ESH3Z2	Rohde & Schwarz	NONE	25-Jan-14

### 8.2 Environmental Condition

Test Place : Shielded Room  
 Temperature (°C) : 23.5 °C  
 Humidity (% R.H.) : 45.9 % R.H.



**ESTECH Co., Ltd.**

Rm 1015, World Venture Center II,  
426-5 Gasan-dong, Guncheon-gu,  
Seoul, 158 803, Korea



**Electromagnet  
Interference  
Test Report**

### 8.3 Test data

Test Date : 28-Feb-13

Frequency (MHz)	Correction Factor		Line (H/N)	Quasi-peak Value			Average Value		
	Lisn (dB)	Cable (dB)		Limit (dB $\mu$ V)	Reading (dB $\mu$ V)	Result (dB $\mu$ V)	Limit (dB $\mu$ V)	Reading (dB $\mu$ V)	Result (dB)
0.20	0.13	0.16	H	63.61	39.1	39.34	53.61		
0.27	0.13	0.17	N	61.12	36.4	36.72	51.12		
13.52	0.33	0.42	N	60.00	49.8	50.56	50.00	19.57	20.32
13.74	0.40	0.42	H	60.00	35.0	35.78	50.00		
21.65	0.65	0.46	N	60.00	35.9	36.96	50.00		
21.82	0.87	0.46	H	60.00	35.3	36.62	50.00		
Remark	H : Hot Line, N : Neutral Line *Correction Factor = Lisn + Cable *Result = Correction Factor + Reading								





**ESTECH Co., Ltd.**

Rm 1015, World Venture Center II,  
426-5 Gasan-dong, Guncheon-gu,  
Seoul. 158-803, Korea



**Electromagnetic  
Interference  
Test Report**

## 9. Photographs of test setup

### 9.1 Setup for Radiated Test

[ Test setup for below 30 MHz ]



[ Test setup for above 30 MHz ]

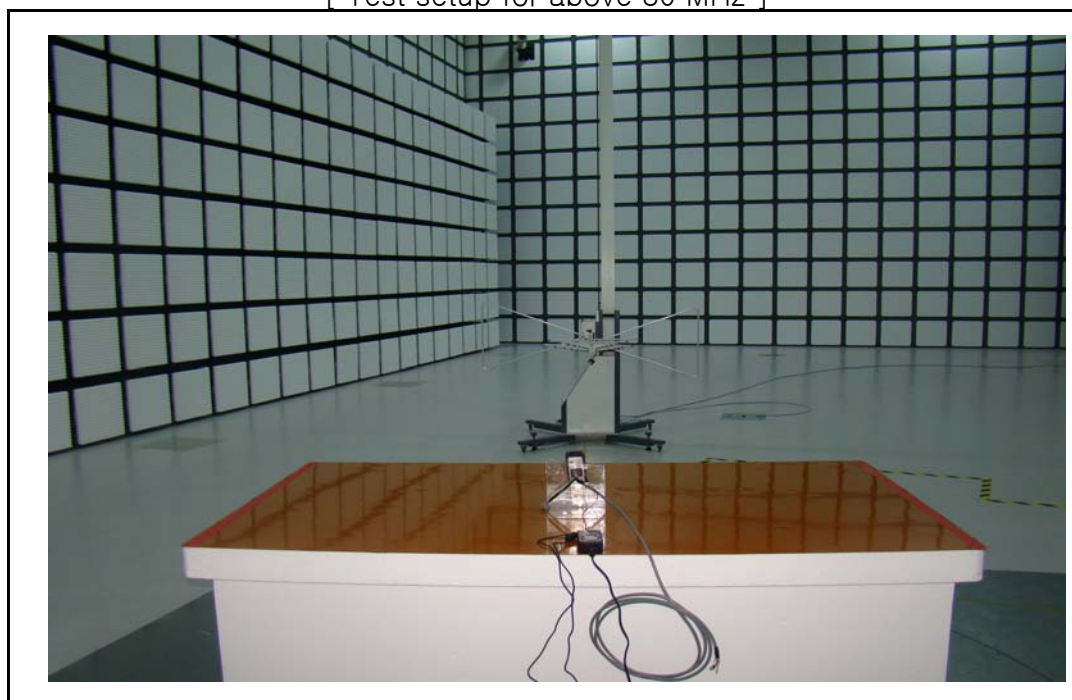



**ESTECH Co., Ltd.**

Rm 1015, World Venture Center II,  
426-5 Gasan-dong, Guncheon-gu,  
Seoul. 158-809, Korea



**Electromagnetic  
Interference  
Test Report**

## 9.2 Setup for Radiated Test : Above 1 GHz

[ Front ]

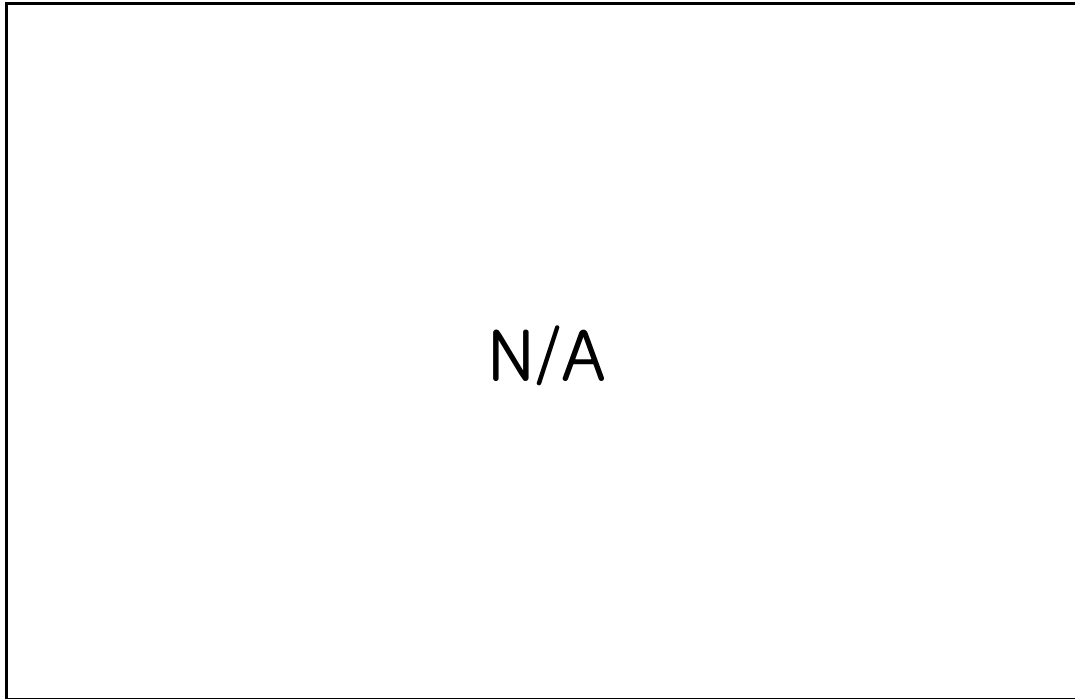

[ Rear ]

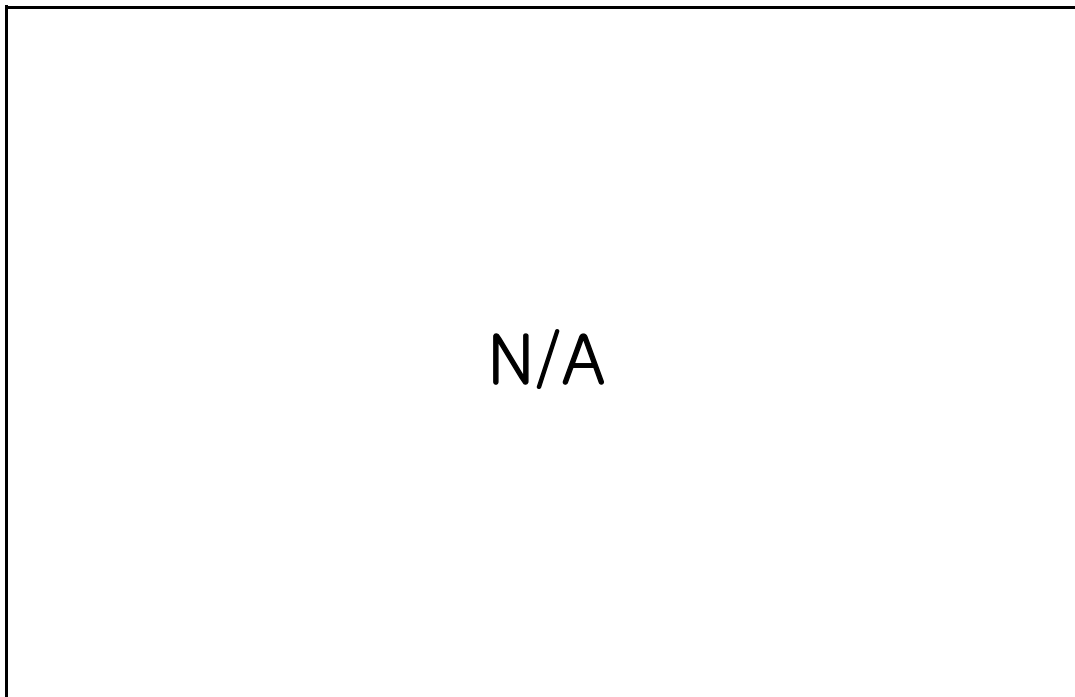



**ESTECH Co., Ltd.**

Rm 1015, World Venture Center 11,  
426-5 Gasan-dong, Guncheon-gu,  
Seoul 158-803, Korea



**Electromagnetic  
Interference  
Test Report**

### 9.3 Setup for Conducted Test : 0.15 MHz ~ 30 MHz

[ Front ]



[ Rear ]





**ESTECH Co., Ltd.**

Rm 1015, World Venture Center 11,  
426-5 Gasan-dong, Guncheon-gu,  
Seoul, 158-808, Korea



**Electromagnetic  
Interference  
Test Report**

## 10.0 Photographs of EUT

[ Front ]



[ Rear ]



# Appendix 1. Special diagram

\*HOT LINE

ES TECH

28 Feb 2013 10:03

HOT

EVT: BEW-OC  
 Manuf:  
 Op Cond: 120 V  
 Operator: Engineer S.B.Lee  
 Test Spec: CLASS B  
 Comment:

Result File: 130304\_h.dat :

Scan Settings

(1 Range)

Frequencies			Receiver Settings					
Start	Stop	Step	IF BW	Detector	M-Time	Atten	Preamp	OpRge
150kHz	30MHz	0.8%	10kHz	PK+AV	10msec	Auto	OFF	60dB

Final Measurement: Detectors: X QP / + AV  
 Meas Time: 1sec  
 Subranges: 25  
 Acc Margin: 0 dB

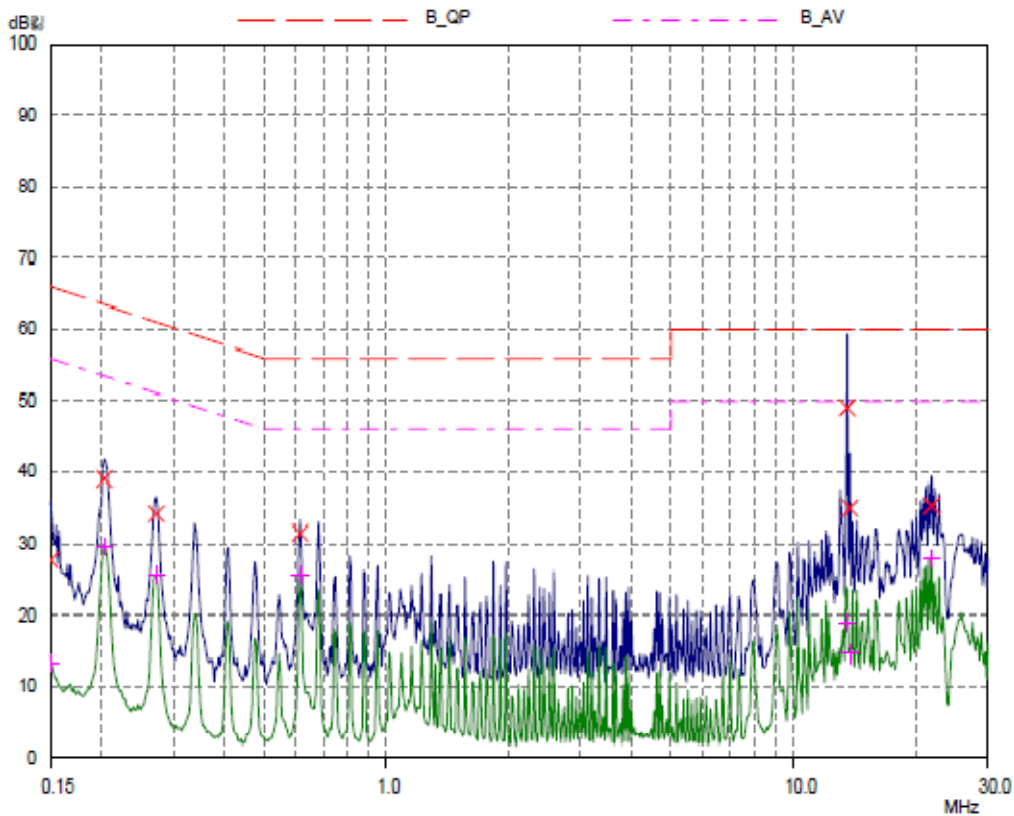

\*NEUTRAL LINE

ES TECH  
NEUTRAL

28 Feb 2013 09:55

EUT: BEWI-OC  
 Manuf:  
 Op Cond: 120 V  
 Operator: Engineer S.B.Lee  
 Test Spec: CLASS B  
 Comment:

Result File: 130304\_n.dat :

Scan Settings			(1 Range)		Receiver Settings				
Start	Stop	Step	IF BW	Detector	M-Time	Atten	Preamp	OpRge	
150kHz	30MHz	0.8%	10kHz	PK+AV	10msec	Auto	OFF	60dB	

Final Measurement:	Detectors:	X QP / + AV
	Meas Time:	1sec
	Subranges:	25
	Acc Margin:	0 dB

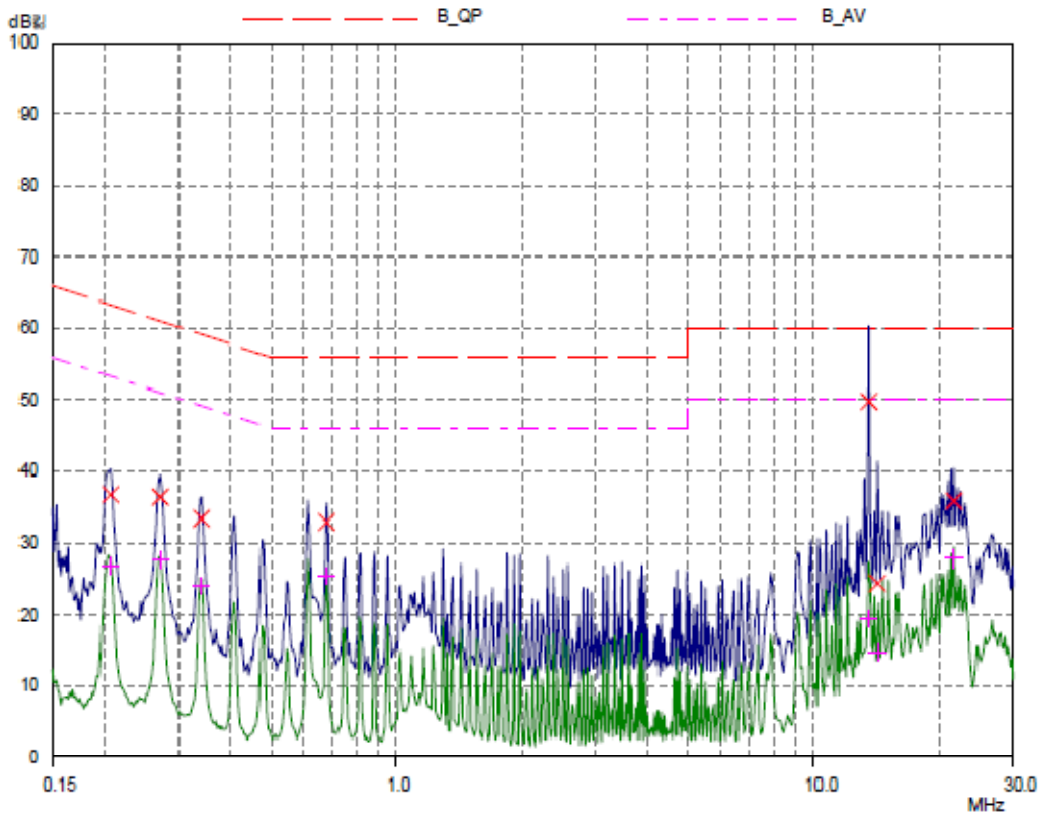

## Appendix 2. Antenna Requirement

### Regulation

According to §15.203, an intentional radiator shall be designed to ensure that no antenna other than that furnished by the responsible party shall be used with the device. The use of a permanently attached antenna or of an antenna that uses a unique coupling to the intentional radiator shall be considered sufficient to comply with the provisions of this Section. The manufacturer may design the unit so that a broken antenna can be replaced by the user, but the use of a standard antenna jack or electrical connector is prohibited.

### Result

-Complied

The transmitter has an integral PCB pattern antenna.