

Test Report for FCC

FCC ID : TKWBEWHOC

Report Number		ESTF151303-006			
Applicant	Company name	Suprema Inc.			
	Address	16F Parkview Tower, Jeongja-dong, Bundang-gu, Seongnam, Gyeonggi, 463-863 Korea			
	Telephone	+82-31-710-2494			
Product	Product name	BioEntry W			
	Model No.	BEWH-OC	Manufacturer	Suprema Inc.	
	Serial No.	NONE	Country of origin	KOREA	
Test date	7-Mar-13		Date of issue	14-Mar-13	
Testing location	ESTECH Co., Ltd. 97-1 Hoiuk-Ri Majang-Myon, Icheon-Si, KyungKi-Do, Korea				
Standard	FCC PART 15 (2010) , ANSI C 63.4 2003				
Test item	<input checked="" type="checkbox"/> Conducted Emission	<input type="checkbox"/> Class A	<input checked="" type="checkbox"/> Class B	Test result	OK
	<input checked="" type="checkbox"/> Radiated Emission	<input type="checkbox"/> Class A	<input checked="" type="checkbox"/> Class B	Test result	OK
Measurement facility registration number	915135				
Tested by	Senior Engineer J.H.KIM		(Signature)		
Reviewed by	Engineering Manager J.M.Yang		(Signature)		
Abbreviation	OK, Pass = Complied, Fail = Failed, N/A = not applicable				
* Note - This test report is not permitted to copy partly without our permission - This test result is dependent on only equipment to be used - This test result based on a single evaluation of one sample of the above mentioned					

Contents

1. Laboratory Information	3
2. Description of EUT	4
3. Test Standards	5
4. Measurement condition	6
5. Measurement of radiated emission	8
5.1 Radiated emission limits, general requirements	8
5.2 Measurement equipment	8
5.3 Environmental conditions	8
5.4 Test data	9
6. Measurement of conducted emission	10
6.1 Measurement equipment	10
6.2 Environmental conditions	10
6.3 Test data	11
7. Photographs of test setup	12
8. Photographs of EUT	14

Appendix 1. Special diagram
Appendix 2. Antenna Requirement



1. Laboratory Information

1.1 General

This EUT (Equipment Under Test) has been shown to be capable of compliance with the applicable technical standards and is tested in accordance with the measurement procedures as indicated in this report. ESTECH Lab attests to accuracy of test data. All measurement reported herein were performed by ESTECH Co., Ltd.

ESTECH Lab assume full responsibility for the completeness of these measurements and vouch for the qualifications of all persons taking them.

1.2 Test Lab.

Corporation Name : ESTECH Co., Ltd.

Head Office : Rm 1015, World Venture Center II, 426-5, Gasan-dong, Geumcheon-gu, Seoul, Korea
(Safety & Telecom. Test Lab)

EMC Test Lab : 97-1 Hoiuk-Ri Majang-Myon, Icheon-city, KyungKi-Do, Korea

1.3 Official Qualification(s)

KCC : Granted Accreditation from Ministry of Information & Communication for EMC, Safety and Telecommunication

KOLAS : Accredited Lab By Korea Laboratory Accreditation Schema base on CENELEC

FCC : Filed Laboratory at Federal Communications Commission

VCCI : Granted Accreditation from Voluntary Control Council for Interference from ITE

2. Description of EUT

2.1 Summary of Equipment Under Test

Product : BioEntry W
 Model Number : BEWH-OC
 Serial Number : NONE
 Manufacturer : Suprema Inc.
 Country of origin : KOREA
 Operating Frequency : 125.1 kHz
 Antenna Type : Loop Antenna
 Modulation Type : ASK
 Channel Spacing : 1

Power Rating : INPUT : (100 – 240) Va.c., (50 – 60) Hz, 1.0 A
 : OUTPUT : 12 Vd.c., 2.5 A
 : PoE : Power over Ethernet

Receipt Date : 14-Feb-13

X-tal list(s) or Frequencies generated : CPU : 533 MHz DSP

2.2 General descriptions of EUT

System	Max Users		5000 users (10,000 templates) [1:1 & 1:N]
	Log Capacity		50,000 logs
	CPU		533MHz DSP
	Memory		8MB Flash + 8MB RAM
	RF Options		125KHz HID PROX
	Interfaces		TCP/IP, RS485, Wiegand
	Input / Output		2 TTL Inputs, 1 Relay Output
	Power		12VDC, PoE (Power over Ethernet)
General	Dimensions	BioEntry W (W x H x D)	50 x 172 x 44 mm
		Wall Bracket (W x H)	40 x 157 mm (screw joint included)

3. Test Standards

Test Standard : FCC PART 15 (2010)

This Standard sets out the regulations under which an intentional, unintentional, or incidental radiator may be operated without an individual license. It also contains the technical specifications, administrative requirements and other conditions relating to the marketing of Part 15 devices.

Test Method : ANSI C 63.4 (2003)

This standard sets forth uniform methods of measurement of radio-frequency (RF) signals and noise emitted from both unintentional and intentional emitters of RF energy in the frequency range 9 kHz to 40 GHz. Methods for the measurement of radiated and AC power-line conducted radio noise are covered and may be applied to any such equipment unless otherwise specified by individual equipment requirements. These methods cover measurement of certain devices that deliberately radiate energy, such as intentional emitters, but does not cover licensed transmitters. This standard is not intended for certification/approval of avionic equipment or for industrial, scientific, and medical (ISM) equipment. These methods apply to the measurement of individual units or systems comprised of multiple units.

Summary of Test Results

Applied Standard : 47 CFR Part 15, Subpart C				
Standard	Test Type	Result	Remark	Limit
15.203	Antenna Requirement	Pass	See Appendix 2	
15.207	AC Power Conducted Emission	Pass	Meet the requirement	
15.205	Restricted bands	Pass	Meet the requirement	
15.209	Radiated Emission	Pass	Meet the requirement	



ESTECH Co., Ltd.

Rm 1015, World Venture Center II,
426-5 Gasan-dong, Guncheon-gu,
Seoul. 158-803. Korea



**Electromagnetic
Interference
Test Report**

4. Measurement Condition

4.1 EUT Operation.

- The EUT was in the following operation mode during all testing
 1. EUT Configuration and Peripherals such as connection settings
 2. 125 kHz RF Signal Transmit / Receive the best action status to the test.

4.2 Configuration and Peripherals

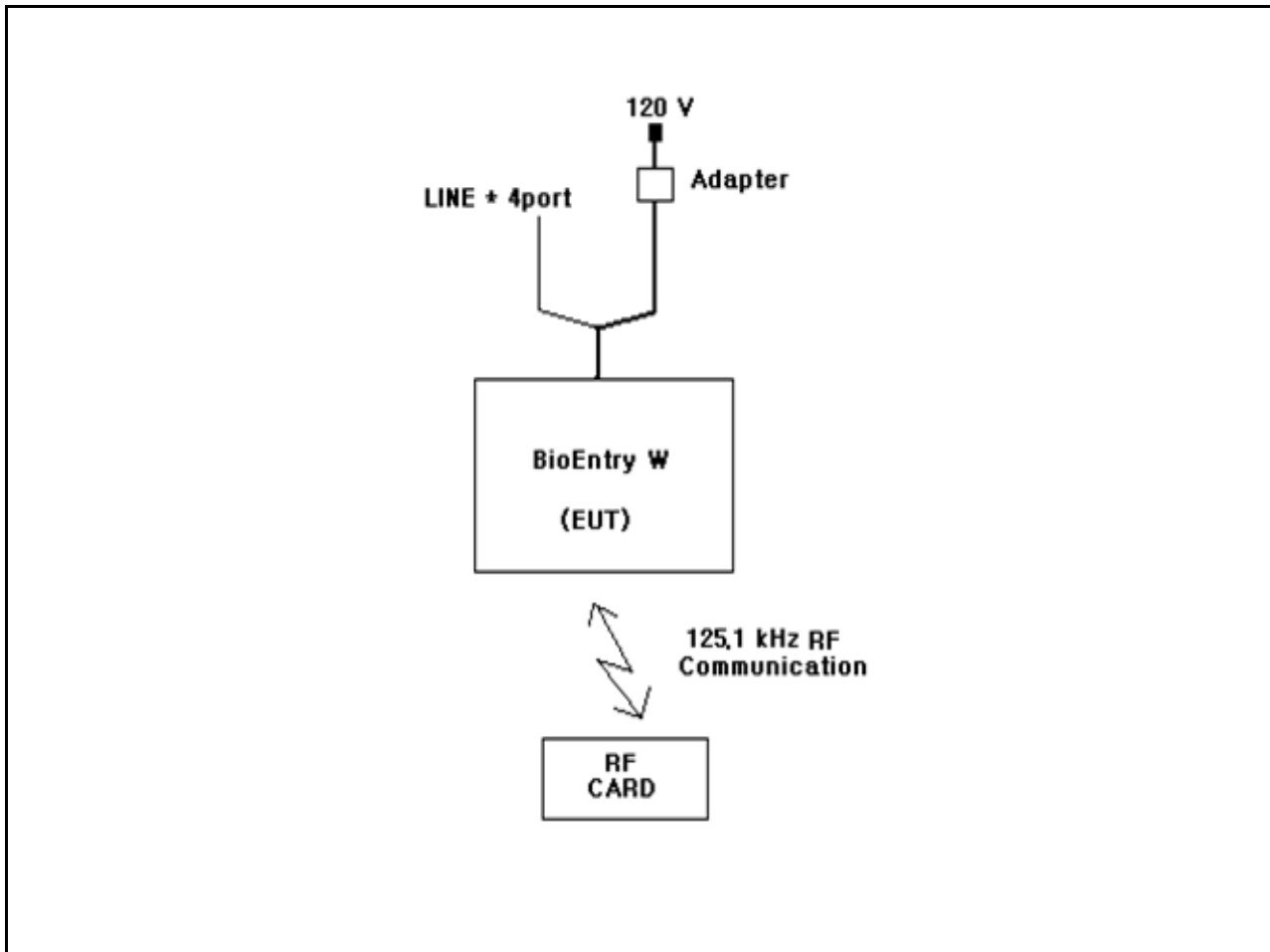

4.3 EUT and Support equipment

Equipment Name	Model Name	S/N	Manufacturer	Remark (FCC ID)
BioEntry W	BEWH-OC	NONE	Suprema Inc.	EUT
Adapter	JPW128KA1200N05	NONE	BridgePower Corp.	
RF CARD	NONE	NONE	Suprema Inc.	

4.4 Cable Connecting

Start Equipment		End Equipment		Cable Standard		Remark
Name	I/O port	Name	I/O port	Length	Shielded	
BioEntry W	LINE(RS-485)	RS232 to RS422/485 Converter	LINE(RS-485)	3	Unshielded	
BioEntry W	POWER	Adapter	-	2	Unshielded	
BioEntry W	125 KHz RF Signal	RF CARD	125 KHz RF Signal	-	-	
BioEntry W	LINE(Relay)	-	-	3	Unshielded	
BioEntry W	LINE(Wiegand)	-	-	3	Unshielded	
BioEntry W	LINE(Switch)	-	-	3	Unshielded	

5. Measurement of radiated disturbance

The EUT was placed on the top of a rotating table 0.8 m above the ground at a 3 m Open test site. The table was rotated 360 ° to determine the position of the highest radiation. Then antenna is a loop antenna is fixed at one meter above the ground to determine the maximum value of the field strength. Both parallel and perpendicular of the antenna are set to make the measurement. For each suspected emission, the EUT was arranged to its worst case and then the table was turned from 0 degrees to 360 ° to find the maximum reading. The test-receiver system was set to Peak Detect Function and Specified Bandwidth with Maximum Hold Mode.

5.1 Radiated emission limits, general requirements

Except as provided elsewhere in this Subpart, the emissions from an intentional radiator shall not exceed the field strength levels specified in the following table:

Frequency (MHz)	Field Strength(microvolt/meter)	Distance(meter)
0.009-0.490	2400/F(KHz)	300
0.490-1.705	24000/F(KHz)	30
1.705-30	30	30
30-88	100**	3
88-216	150**	3
216-960	200**	3
Above 960	500	3

* dBuV/m=20*log(uV/m) * Distance factor=40dB / decade(15.31(f))

5.2 Measurement equipments

Equipment Name	Type	Manufacturer	Serial No.	Next Calibration date
TEST Receiver	ESCI7	ROHDE & SCHWARZ	1166.5950.07	25-Jan-14
Logbicon Antenna	VULB 9168	SCHWARZBECK	9168-193	22-May-13
Turn Table	DT3000-2t	Innco System GmbH	N/A	-
Antenna Mast	MA4000-EP	Innco System GmbH	N/A	-
Antenna Master & Turn table controller	CO2000-P	Innco System GmbH	CO2000/641 /28051111/L	-
Loop Antenna	HFH2-Z2	ROHDE & SCHWARZ	100188	27-Jul-13

5.3 Environmental Condition

Test Place : Open site(3m)
 Temperature (°C) : 24.2 °C
 Humidity (%) : 40.3 % R.H.

5.4 Test data (9 kHz ~ 30 MHz)

Test Date : 7-Mar-13

Measurement Distance : 3 m

Frequency (kHz)	Reading (dB μ V)	Position (V/H)	Height (m)	Correction Factor		Result Value(Qeas-Peak)		
				Ant Factor	Cable (dB)	Limit (dB μ V/m)	Result (dB μ V/m)	Margin (dB)
125.00	45.78	H	1.0	18.80	0.1	105.7	64.66	-41.01
Remark	<p>H : Horizontal, V : Vertical There did not measure any radiated spurious emission in the range 9 kHz to 30 MHz *There is no found Restricted bands. *The 300 m limit was converted to 3m Limit using square factor(x) as it was found by measurements as follows: 3 m Limit(dBuV/m) = 20log(2400/F(KHz))+40log(300/3)= 20log(2400/125)+40log(300/3)</p>							



ESTECH Co., Ltd.

Rm 1015, World Venture Center II,
426-5 Gasan-dong, Guncheon-gu,
Seoul, 158-803, Korea



**Electromagnetic
Interference
Test Report**

5.4 Test data(30 MHz ~ 1 000 MHz)

Test Date : 7-Mar-13

Measurement Distance : 3 m

Frequency (MHz)	Reading (dB μ V)	Position (V/H)	Height (m)	Correction Factor		Result Value(Quasi-peak)		
				Ant Factor (dB)	Cable (dB)	Limit (dB μ V/m)	Result (dB μ V/m)	Margin (dB)
32.10	13.94	V	1.0	12.71	1.04	40.00	27.70	12.30
76.70	19.07	V	1.0	10.86	1.47	40.00	31.40	8.60
81.00	10.31	H	4.0	10.18	1.51	40.00	22.00	18.00
125.00	12.52	V	1.0	11.35	1.83	43.50	25.70	17.80
158.30	10.59	H	2.6	13.62	1.99	43.50	26.20	17.30
175.00	13.23	V	1.0	12.22	2.15	43.50	27.60	15.90
330.90	11.62	H	1.4	14.46	2.82	46.00	28.90	17.10
475.00	13.02	H	1.0	17.48	3.40	46.00	33.90	12.10
508.30	11.72	V	1.0	18.15	3.52	46.00	33.40	12.60
575.00	13.41	V	1.0	19.47	3.73	46.00	36.60	9.40
625.00	15.23	V	1.4	20.27	3.90	46.00	39.40	6.60
658.30	15.59	V	1.2	20.68	4.03	46.00	40.30	5.70
933.30	8.02	H	1.0	24.12	4.77	46.00	36.90	9.10
Remark	<p>H : Horizontal, V : Vertical *Result Value = Reading + Antenna + Cable loss *Correction Factor = Ant Factor + Cable *The resolution bandwidth and video bandwidth of test receiver/spectrum analyzer is 120 kHz for Quasi-peak detection</p>							

6. Measurement of conducted disturbance

The continuous disturbance voltage of AC Mains in the frequency from 0.15 MHz to 30 MHz was measured in accordance to FCC Part 15 (2010) & ANSI C 63.4 (2003) The test setup was made according to FCC Part 15 (2010) & ANSI C 63.4 (2003) in a shielded Room. The EUT was placed on a non-conductive table at least 0.8 m above the ground plan. A grounded vertical reference plane was positioned in a distance of 0.4 m from the EUT. The distance from the EUT to other metal surfaces was at least 0.8 m. The EUT was only earthen by its power cord through the line impedance stabilizing network. The power cord has been bundled to a length of 1.0 m. The test receiver with Quasi Peak detector complies with CISPR 16.

6.1 Measurement equipments

Equipment Name	Type	Manufacturer	Serial No.	Next Calibration date
TEST Receiver	ESHS 30	Rohde & Schwarz	828765/002	25-Jan-14
LISN	ESH3-Z5	Rohde & Schwarz	838979/010	25-Jan-14
Pulse Limiter	ESH3Z2	Rohde & Schwarz	NONE	25-Jan-14

6.2 Environmental Condition

Test Place : Shielded Room
 Temperature (°C) : 24.1 °C
 Humidity (% R.H.) : 48.1 % R.H.



ESTECH Co., Ltd.

Rm 1015, World Venture Center 11,
426-5 Gasan-dong, Guncheon-gu,
Seoul, 158-803, Korea



**Electromagnet
Interference
Test Report**

6.3 Test data

Test Date : 7-Mar-13

Frequency (MHz)	Correction Factor		Line (H/N)	Quasi-peak Value			Average Value		
	Lisn (dB)	Cable (dB)		Limit (dB μ V)	Reading (dB μ V)	Result (dB μ V)	Limit (dB μ V)	Reading (dB μ V)	Result (dB)
0.20	0.13	0.16	N	63.61	37.8	38.08	53.61		
0.27	0.13	0.17	H	61.12	33.5	33.83	51.12		
0.61	0.11	0.18	H	56.00	33.3	33.62	46.00		
20.47	0.78	0.45	H	60.00	35.6	36.87	50.00		
20.82	0.80	0.45	H	60.00	34.5	35.80	50.00		
21.47	0.65	0.46	N	60.00	33.0	34.10	50.00		
Remark	H : Hot Line, N : Neutral Line *Correction Factor = Lisn + Cable *Result = Correction Factor + Reading								



ESTECH Co., Ltd.

Rm 1015, World Venture Center 11,
426-5 Gasan-dong, Guncheon-gu,
Seoul. 158-803, Korea



**Electromagnetic
Interference
Test Report**

7. Photographs of test setup

7.1 Setup for Radiated Test

[Test setup for below 30 MHz]



[Test setup for above 30 MHz]



7.3 Setup for Conducted Test : 0.15 MHz ~ 30 MHz

[Front]



[Rear]





ESTECH Co., Ltd.

Rm 1015, World Venture Center II,
426-5 Gasan-dong, Guncheon-gu,
Seoul. 158-803. Korea



**Electromagnetic
Interference
Test Report**

8.0 Photographs of EUT

[Front]



[Rear]





ESTECH Co., Ltd.

Rm 1015, World Venture Center II,
426-5 Gasan-dong, Guncheon-gu,
Seoul, 158-803, Korea



**Electromagnetic
Interference
Test Report**

8.1 Photographs of EUT

[Front]



[Label]

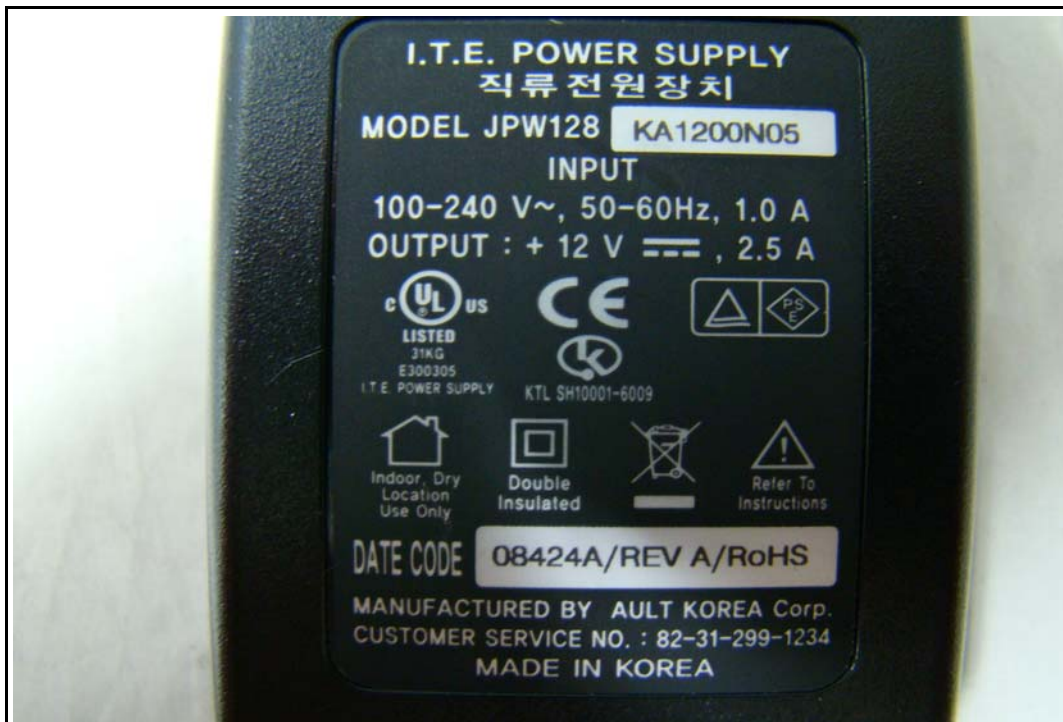

Appendix 1. Special diagram

*HOT LINE

ES TECH
HOT LINE

07 Mar 2013 10:43

EUT: BEWH-OC
 Manuf:
 Op Cond: 120 V
 Operator: J.H.KIM
 Test Spec: CLASS B
 Comment:

Result File: 130308_h.dat :

Scan Settings (1 Range)

Frequencies			Receiver Settings					
Start	Stop	Step	IF BW	Detector	M-Time	Atten	Preamp	OpRge
150kHz	30MHz	0.8%	10kHz	PK+AV	10msec	Auto	OFF	60dB

Final Measurement: Detectors: X QP / + AV
 Meas Time: 1sec
 Subranges: 25
 Acc Margin: 0 dB

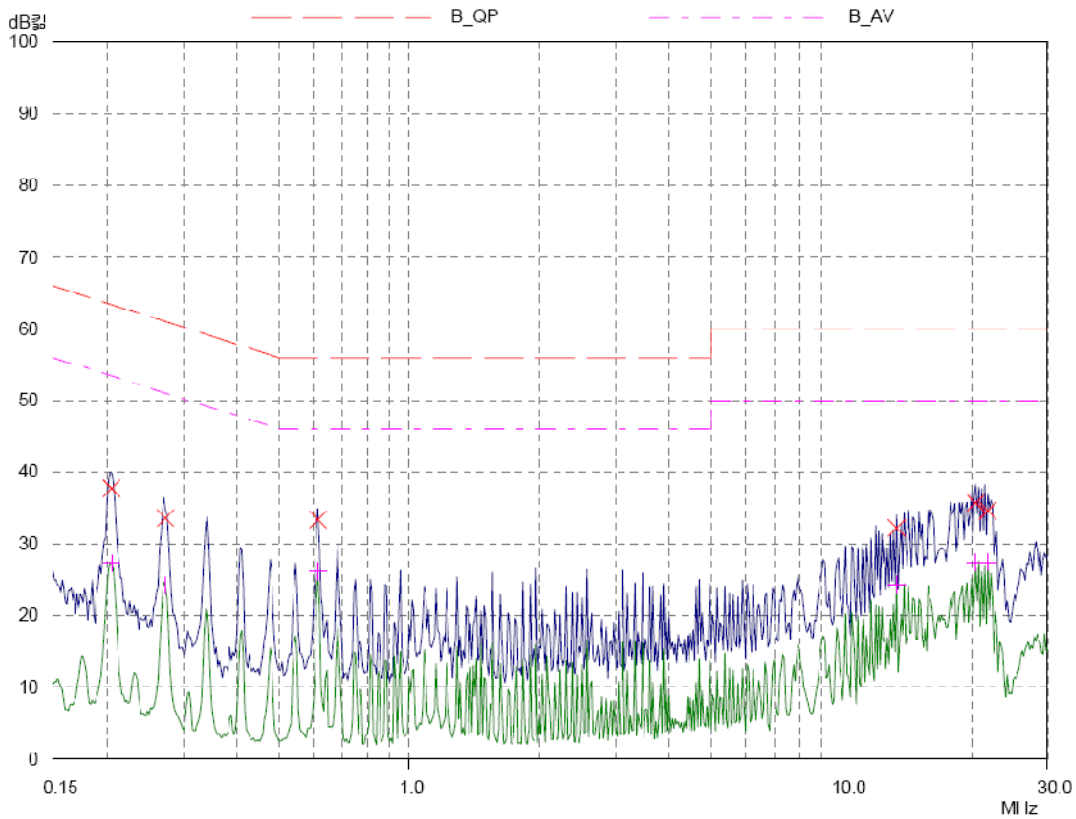

***NEUTRAL LINE**

ES TECH
NEUTRAL LINE

07 Mar 2013 10:48

EUT: BEWH CC
 Manuf:
 Op Cond: 120 V
 Operator: J.H.KIM
 Test Spec: CLASS B
 Comment:

Result File: 130306_n.dat :

Scan Settings (1 Range)

Frequencies			Receiver Settings						
Start	Stop	Step	IF BW	Detector	M-Time	Atten	Preamp	CpRge	
150kHz	30MHz	0.8%	10kHz	PK+AV	10msec	Auto	OFF	60dB	

Final Measurement: Detectors: X QP / + AV
 Meas Time: 1sec
 Subranges: 25
 Acc Margin: 0 dB

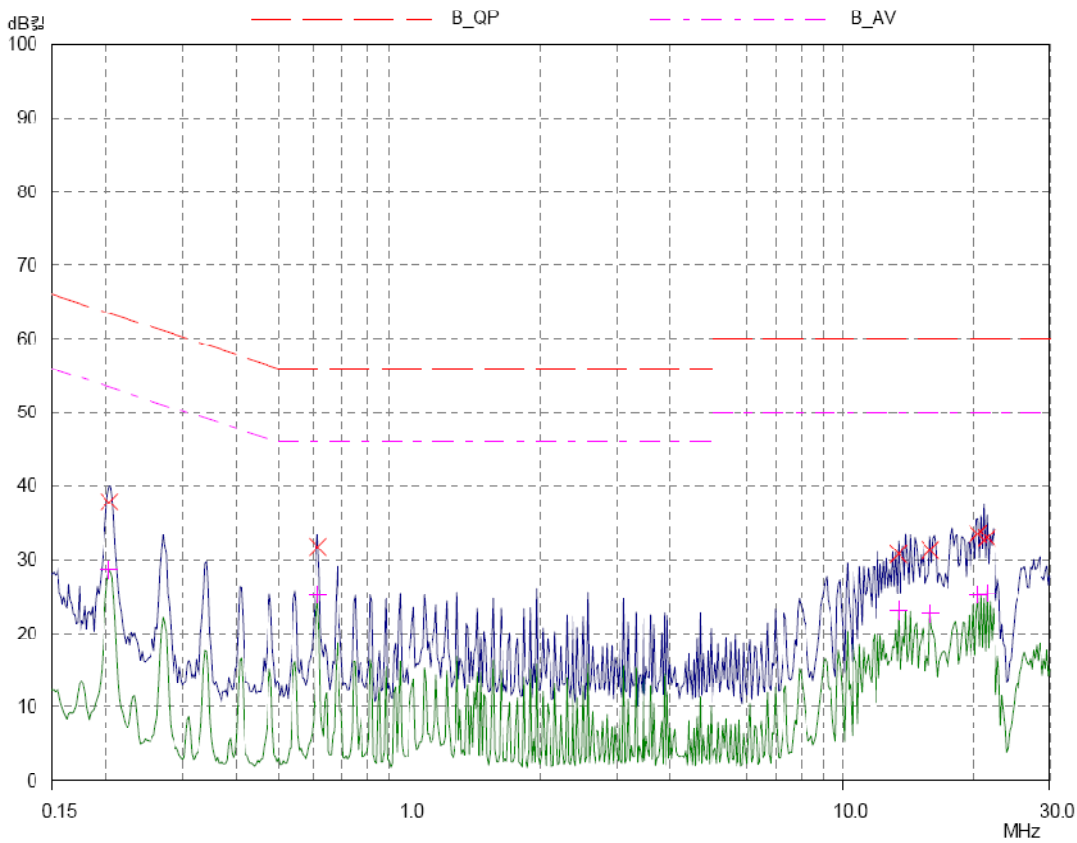

Appendix 2. Antenna Requirement

Regulation

According to §15.203, an intentional radiator shall be designed to ensure that no antenna other than that furnished by the responsible party shall be used with the device. The use of a permanently attached antenna or of an antenna that uses a unique coupling to the intentional radiator shall be considered sufficient to comply with the provisions of this Section. The manufacturer may design the unit so that a broken antenna can be replaced by the user, but the use of a standard antenna jack or electrical connector is prohibited.

Result

-Complied

The transmitter has an integral Loop coil antenna.