



Test Report for FCC

FCC ID :TKWBER2-OD

Report Number		ESTRFC1708-003		
Applicant	Company name	Suprema Inc		
	Address	16F Parkview office Tower, Jeongja-dong Bundang-gu, Seongnam, Gyeonggi		
	Telephone	+82-31-710-4908		
Contact person		Bongseop Song		
Product	Product name	BioEntry R2		
	Model No.	BER2-OD	Manufacturer	Suprema Inc
	Serial No.	None	Country of origin	KOREA
Test date	2017-07-20 ~ 2017-07-24		Date of issue	1-Aug-17
Testing location	347-69, Jungbu-daero 147beon-gil, Majang-myeon, Icheon-si, Gyeonggi-do 467-811, R. O. Korea			
Standard	FCC PART 15 Subpart C(15.225), ANSI C 63.10(2013)			
Result		Complied		
Measurement facility registration number		659627		
Tested by	Senior Engineer H.G. Lee		(Signature)	
Reviewed by	Engineering Manager I.k. Hong		(Signature)	
Abbreviation	OK, Pass = Complied, Fail = Failed, N/A = not applicable			
<p>* Note</p> <ul style="list-style-type: none"> - This test report is not permitted to copy partly without our permission - This test result is dependent on only equipment to be used - This test result based on a single evaluation of one sample of the above mentioned 				



Contents

1. Laboratory Information	3
2. Description of EUT	4
3. Test Standards	5
4. Measurement condition	6
5. 20dBm Bandwidth	8
5.1 Procedure	8
5.2 20dBm Bandwidth Set up	8
5.3 Measurement Data	8
6. Frequency Tolerance	10
6.1 Procedure	10
6.2 Test Equipments	10
6.3 Measurement Data	11
7. Measurement of radiated emission	13
7.1 Radiated emission limits, general requirements	13
7.2 Measurement equipment	13
7.3 Environmental conditions	13
7.4 Test data(9 kHz ~30 MHz)	14
7.5 Test data(30 MHz ~ 1 GHz)	15
7.6 Test data(Above 1 GHz)	16
8. Measurement of conducted emission	17
8.1 Measurement equipment	17
8.2 Environmental conditions	17
8.3 Test data	18
Appendix 1. Special diagram(Adapter Mode)	
Appendix 2. Antenna Requirement	



1. Laboratory Information

1.1 General

This EUT (Equipment Under Test) has been shown to be capable of compliance with the applicable technical standards and is tested in accordance with the measurement procedures as indicated in this report. ESTECH Lab attests to accuracy of test data. All measurement reported herein were performed by ESTECH Co., Ltd.

ESTECH Lab assume full responsibility for the completeness of these measurements and vouch for the qualifications of all persons taking them.

1.2 Test Lab.

Corporation Name : ESTECH Co., Ltd.

Head Office : Suite 1015 World Meridian II, 123 Gasan Digital 2-ro, Geumcheon-gu,
Seoul 153-759, R. O. Korea

EMC/Telecom/Safety Test Lab : 347-69, Jungbu-daero 147beon-gil, Majang-myeon, Icheon-si,
Gyeonggi-do 467-811, R. O. Korea

1.3 Official Qualification(s)

MSIP : Granted Accreditation from Ministry of Information & Communication for EMC, Safety and Telecommunication

KOLAS : Accredited Lab By Korea Laboratory Accreditation Schema base on CENELEC requirements

FCC : Conformity Assessment Body(CAB) with registration number 659627 under APEC TEL MRA between the RRA and the FCC

VCCI : Granted Accreditation from Voluntary Control Council for Interference from ITE



Estech
your best partner

2. Description of EUT

2.1 Summary of Equipment Under Test

Product : BioEntry R2
Model Number : BER2-OD
Serial Number : NONE
Manufacturer : Suprema Inc
Country of origin : KOREA
Operating Frequency : 13.56 MHz
Antenna Type : PCB Patten Antenna
Modulation Type : ASK
Channel : 1 ch

Power Rating : INPUT : (100 – 240) Va.c., (50 – 60) Hz, 1.0 A
: OUTPUT : 12 Vd.c., 2.5 A

Receipt Date : 14-Jul-17

X-tal list(s) or : The highest operating frequency is CPU 1.0 GHz
Frequencies generated



2.2 General descriptions of EUT

Category	Feature	Specification
Credential	Biometric	Fingerprint
	RF Option	*BER2-OD: 132kHz EM & 13.56MHz MIFARE, MIFARE Plus, DESFire/EV1, FeliCa, NFC
	RF read range *	MIFARE/DESFire/EM/HID Prox/iCLASS : 50 mm, FeliCa: 30 mm
General	CPU	1.0 GHz
	Memory	32MB Flash + 32MB RAM
	LED	Multi-color
	Sound	Multi-tone Buzzer
	Operating temperature	-20°C - 50°C
	Storage temperature	-40°C - 70°C
	Operating humidity	0% - 80%, non-condensing
	Dimension (W x H x D)	50mm x 164mm x 37.5mm
	Weight	Device: 162g
Fingerprint	Image dimension	272 x 320 pixels
	Image bit depth	8bit, 256 grayscale
	Resolution	500 dpi
	Template	SUPREMA / ISO 19794-2 / ANSI 378
	Extractor	MINEX certified and compliant
Electrical	Power	Voltage: DC 12V Current: Max. 600 mA
Capacity	Max. User (1:1)	10,000
	Max. User (1:N)	10,000
	Max. Template (1:1)	20,000 (Two templates per finger)
	Max. Template (1:N)	20,000 (Two templates per finger)
	Max. Text Log	1,000,000
Interface	Tamper	Supported
	RS-485	1ch Master / Slave (Selectable)

* RF read range will vary depending on the installation environment.

3. Test Standards

Test Standard : FCC PART 15 Subpart C(15.225)

This Standard sets out the regulations under which an intentional, unintentional, or incidental radiator may be operated without an individual license. It also contains the technical specifications, administrative requirements and other conditions relating to the marketing of Part 15 devices.

Test Method : ANSI C 63.10 (2013)

This standard sets forth uniform methods of measurement of radio-frequency (RF) signals and noise emitted from both unintentional and intentional emitters of RF energy in the frequency range 9 kHz to 40 GHz. Methods for the measurement of radiated and AC power-line conducted radio noise are covered and may be applied to any such equipment unless otherwise specified by individual equipment requirements. These methods cover measurement of certain devices that deliberately radiate energy, such as intentional emitters, but does not cover licensed transmitters. This standard is not intended for certification/approval of avionic equipment or for industrial, scientific, and medical (ISM) equipment. These methods apply to the measurement of individual units or systems comprised of multiple units.

Summary of Test Results

Applied Standard : 47 CFR Part 15, Subpart C				
Standard	Test Type	Result	Remark	Limit
15.203	Antenna Requirement	Pass	Meet the requirement	
15.207	AC Power Conducted Emission	Pass	Meet the requirement	
15.225(a)	Radiated Emission (13.553 ~13.567) MHz	Pass	Meet the requirement	15,848 uV/m at 30 m
15.225(b)	Radiated Emission (13.410 ~13.553 , 13.567 ~ 13.710) MHz	Pass	Meet the requirement	334 uV/m at 30 m
15.225(c)	Radiated Emission (13.110 ~13.410 , 13.710 ~ 14.010) MHz	Pass	Meet the requirement	106 uV/m at 30 m
15.225(d)	Apply section 15.209 (out side band of the 13.110 ~14.010) MHz	Pass	Meet the requirement	
15.225(e)	Frequency stability	Pass	Meet the requirement	
15.215(c)	20dB Bandwidth	Pass	Meet the requirement	

4. Measurement Condition

4.1 EUT Operation.

-The EUT was tested, under transmission / receiving

1. Normal communication with RF OUT Frequency(13.56 MHz).
2. Monitoring the operation status of frequency by using RF CARD.

4.2 Configuration and Peripherals

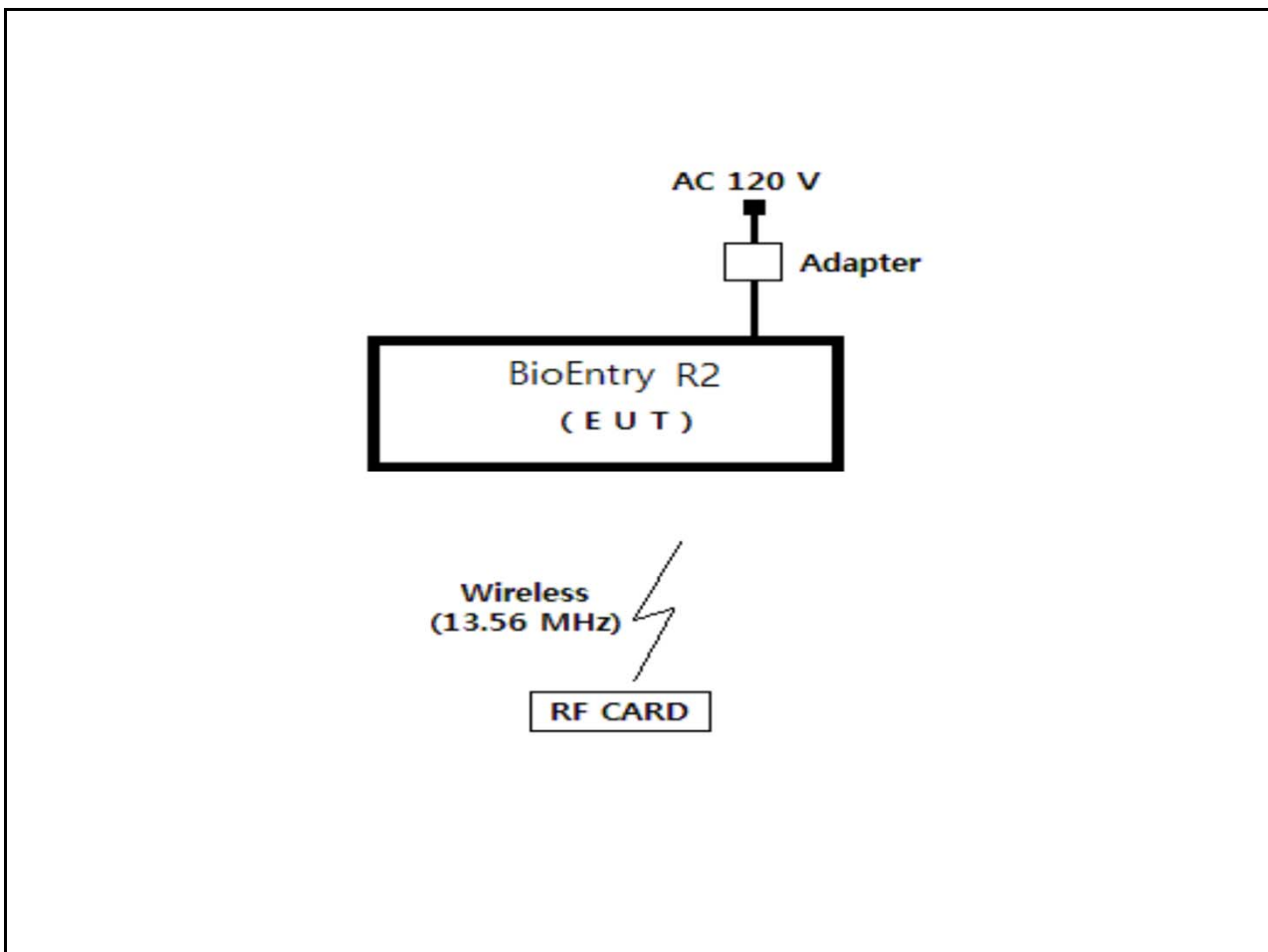



4.3 EUT and Support equipment

Equipment Name	Model Name	S/N	Manufacturer	Remark (FCC ID)
BioEntry R2	BER2-OD	NONE	Suprema Inc	EUT
Adapter	JPW128KA1200N05	NONE	BridgePower Corp.	
RF CARD	NONE	NONE	NONE	

4.4 Cable Connecting

Start Equipment		End Equipment		Cable Standard		Remark
Name	I/O port	Name	I/O port	Length	Shielded	
BioEntry R2	Power	Adapter	-	2.0	Unshielded	
BioEntry R2	Wireless (13.56 MHz)	RF CARD	Wireless (13.56 MHz)	-	-	

5. 20 dB Bandwidth

5.1 Procedure

The transmitter output was connected to the spectrum analyzer. The bandwidth of the fundamental frequency was measured by spectrum analyzer. The 20 dB bandwidth is defined as the bandwidth at 20 dB below from peak power point.

5.2 20dB Bandwidth setup

The spectrum analyzer is set to as following

RBW: 30 Hz

VBW: 300 Hz

Span: 5 kHz

Sweep:suitable duration based on the EUT specification

20dB Bandwidth Test Instruments

Decription	Model	Serial Number	Cal. Due Data
Signal Analyzer	FSV40	100939	4-Jan-18

5.3 Measurement Data

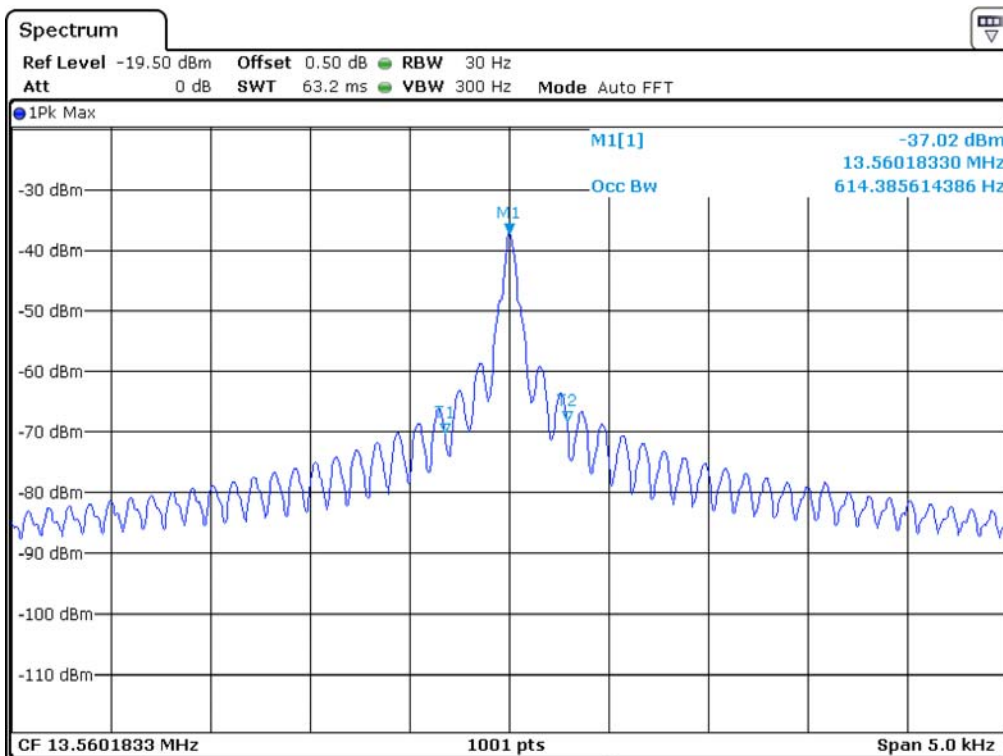

6. Frequency Tolerance

6.1 Procedure

The frequency stability of the transmitter is measured by:

- a) Temperature: The temperature is varied from $-20\text{ }^{\circ}\text{C}$ to $+50\text{ }^{\circ}\text{C}$ using an environmental chamber.
- b) Primary Supply Voltage: The primary supply voltage is varied from 85 % to 115 % of the voltage normally at the input to the device or at the power supply terminals if cables are not normally supplied.

The frequency tolerance of the carrier shall be maintained within $\pm 0.01\%$ of the operating frequency.

6.2 Equipment lists

The following test equipments are used during test

Decription	Model	Serial Number	Cal. Due Data
Signal Analyzer	FSV40	100939	4-Jan-18
Temp./Humidity Chamber	SM-150-2	04-TH24	4-Jan-18



6.3 Measurement Data (Adapter)

Operating Frequency : 13,560,183 Hz
Reference Voltage : 12.00 Vd.c.
Deviation Limit : ± 0.01 %

Voltage (%)	Power (Vdc)	Temperature (°C)	Frequency (Hz)	Deviation (%)
100	12.00	+20 °C (Ref)	13,560,142	-0.000302
100		-20	13,560,155	-0.000206
100		-10	13,560,158	-0.000184
100		0	13,560,166	-0.000125
100		10	13,560,265	0.000605
100		20	13,560,235	0.000383
100		30	13,560,282	0.000730
100		40	13,560,108	-0.000553
100		50	13,560,161	-0.000162
85		10.20	20	13,560,344
115	13.80	20	13,560,356	0.001276

7. Measurement of radiated disturbance

The EUT was placed on the top of a rotating table 0.8 m above the ground at a 10 m semi-anechoic chamber. The table was rotated 360° to determine the position of the highest radiation. Then antenna is a loop antenna is fixed at 1 m above the ground to determine the maximum value of the field strength. Both parallel and perpendicular of the antenna are set to make the measurement. For each suspected emission, the EUT was arranged to its worst case and then the table was turned from 0° to 360° to find the maximum reading. The test receiver system was set to Peak Detect Function and Specified Bandwidth with Maximum Hold Mode.

7.1 Radiated emission limits, general requirements

Except as provided elsewhere in this Subpart, the emissions from an intentional radiator shall not exceed the field strength levels specified in the following table:

Frequency (MHz)	Field strength @30 m (uV/m)	Field strength @30 m (dBuV/m)	Field strength @3m (dBuV/m)
Below 13.110	30	29.5	69.5
13.110 ~13.410	106	40.5	80.5
13.410~13.553	334	50.5	90.5
13.553~13.567	15,848	84	124
13.567~13.710	334	50.5	90.5
13.710~14.010	106	40.5	80.5
Above 14.010	30	29.5	69.5

* dBuV/m=20*log(uV/m) * Distance factor=40dB / decade(15.31(f))

7.2 Measurement equipments

Equipment Name	Type	Manufacturer	Serial No.	Next Calibration date
TEST Receiver	ESCI7	ROHDE & SCHWARZ	100916	5-Nov-17
Logbicon Antenna	VULB 9168	SCHWARZBECK	193	12-Oct-18
Turn Table	DT3000-2t	Innco System GmbH	N/A	-
Antenna Mast	MA4000-EP	Innco System GmbH	N/A	-
Antenna Master & Turn table controller	CO2000-P	Innco System GmbH	CO2000/641 /28051111/L	-
Loop Antenna	HFH2-Z2	ROHDE & SCHWARZ	100188	22-Aug-17

7.3 Environmental Condition

Test Place : 10 m Semi-anechoic chamber

Below 1 GHz

Temperature (°C) : 24.2 °C

Humidity (% R.H.) : 49.1 % R.H.

Test Place : 3 m Semi-anechoic chamber(3 m)

Above 1 GHz-N/A

Temperature (°C) :

Humidity (% R.H.) :



7.4 Test data(9 kHz ~ 30 MHz)

Test Date : 20-Jul-17

Measurement Distance : 3 m

Frequency (MHz)	Reading (dB μ V)	Vertical Position [Angle]	EUT Position	Height (m)	Correction Factor		Result Value(Quasi-Peak)		
					Ant Factor (dB)	Cable (dB)	Limit (dB μ V/m)	Result (dB μ V/m)	Margin (dB)
Below 13.110 MHz									
Noise Floor	-	-	-	-	19.30	0.5	69.5	-	-
13.110 MHz to 13.410 MHz									
Noise Floor	-	-	-	-	19.30	0.5	80.5	-	-
13.410 MHz to 13.553 MHz									
Noise Floor	-	-	-	-	19.30	0.5	90.5	-	-
13.553 MHz to 13.567 MHz									
13.5600	48.00	180 °	X	0.8	19.30	0.4	124.0	67.74	56.26
13.567 MHz to 13.710 MHz									
Noise Floor	-	-	-	-	19.30	0.5	90.5	-	-
13.710 MHz to 14.010 MHz									
Noise Floor	-	-	-	-		0.5	80.5	-	-
14.010 MHz to 30 MHz									
Noise Floor	-	-	-	-	19.20	0.8	69.5	-	-
14.010 MHz to 30 MHz									
Noise Floor	-	-	-	-	19.20	0.8	69.5	-	-
Remark	<p>*The 30 m limit was converted to 3 m Limit using square factor(x) as it was found by measurements as follows: *3 m Limit(dBuV/m) = 20log(X)+40log(30/3)= 20log(15848)+40log(30/3) = 124 dBuV *3 m Limit(dBuV/m) = 20log(X)+40log(30/3)= 20log(30)+40log(30/3) = 69.5 dBuV</p> <p>* The EUT was measured for the worst case by rotating of antenna angle. * The EUT performed at X,Y,Z and recorded the worst data in the report.</p>								

7.5 Test data(30 MHz ~ 1 000 MHz)

Test Date : 20-Jul-17

Measurement Distance : 3 m

Frequency (MHz)	Reading (dB μ V)	Position (V/H)	Height (m)	Correction Factor		Result Value(Quasi-peak)		
				Ant Factor (dB)	Cable (dB)	Limit (dB μ V/m)	Result (dB μ V/m)	Margin (dB)
144.00	21.59	V	1.0	12.78	1.81	43.50	36.18	7.32
254.00	15.87	H	1.4	11.94	2.47	46.00	30.28	15.72
312.00	15.16	H	1.4	13.76	2.76	46.00	31.68	14.32
400.00	19.86	V	1.2	15.63	3.16	46.00	38.65	7.35
600.00	17.69	V	1.4	19.72	3.93	46.00	41.34	4.66
696.00	12.38	V	1.6	20.99	4.26	46.00	37.62	8.38
744.00	9.48	V	1.6	21.71	4.43	46.00	35.62	10.38
800.00	12.46	V	1.4	22.43	4.63	46.00	39.52	6.48
Remark	H : Horizontal, V : Vertical *Result Value = Reading + Antenna + Cable loss *Correction Factor = Ant Factor + Cable *The resolution bandwidth and video bandwidth of test receiver/spectrum analyzer is 120 kHz for Quasi-peak detection							



7.6 Test data (Above 1 GHz) – N / A

Test Date :

Measurement Distance : 3 m

Frequency (MHz)	Reading (dB μ V)	Position (V/H)	Height (m)	Correction Factor		Result Value		
				Ant Factor (dB)	Cable (dB)	Limit (dB μ V/m)	Result (dB μ V/m)	Margin (dB)
Peak(RBW:1 MHz VBW:1 MHz)								
Average(RBW:1 MHz VBW:10 Hz)								
Remark	<p>H : Horizontal, V : Vertical *Reading = receiver reading + Amplifier Gain *CL = Cable Loss–Amplifier Gain *The resolution bandwidth and video bandwidth of spectrum analyzer is 1 MHz and 10 Hz for average detection at frequency above 1 GHz. *This test does not require because the highest operating frequency of the EUT is less than 108 MHz. *Application method of the highest frequency is in the following *Highest frequency of the EUT is less than 108 MHz, the measurement shall only be made up to 1 GHz. *Highest frequency of the EUT is between 108 MHz and 500 MHz, the measurement shall only be made up to 2 GHz. *Highest frequency of the EUT is between 500 MHz and 1 GHz, the measurement shall only be made up to 5 GHz. *Highest frequency of the EUT is above 1 GHz, the measurement shall be made up to 10 times the highest frequency or 40 GHz,</p>							

8. Measurement of conducted disturbance

The continuous disturbance voltage of AC Mains in the frequency from 0.15 MHz to 30 MHz was measured in accordance to FCC Part 15 & ANSI C 63.10 (2013) The test setup was made according to FCC Part 15 & ANSI C 63.10 (2013) in a shielded Room. The EUT was placed on a non-conductive table at least 0.8 m above the ground plan. A grounded vertical reference plane was positioned in a distance of 0.4 m from the EUT. The distance from the EUT to other metal surfaces was at least 0.8 m. The EUT was only earthen by its power cord through the line impedance stabilizing network. The power cord has been bundled to a length of 1.0 m. The test receiver with Quasi Peak detector complies with CISPR 16.

8.1 Measurement equipments

Equipment Name	Type	Manufacturer	Serial No.	Next Calibration date
TEST RECEIVER	ESPI	Rohde & Schwarz	100005	4-Nov-17
LISN	ESH3-Z5	Rohde & Schwarz	836679/025	4-Nov-17
Pulse Limiter	ESH3Z2	Rohde & Schwarz	NONE	4-Nov-17

8.2 Environmental Condition

Test Place : Shielded Room
 Temperature (°C) : 23.5 °C
 Humidity (% R.H.) : 48.8 % R.H.



8.3 Test data

Test Date : 20-Jul-17

Frequency (MHz)	Correction Factor		Line (H/N)	Quasi-peak Value			Average Value		
	Lisn (dB)	Cable (dB)		Limit (dB μ V)	Reading (dB μ V)	Result (dB μ V)	Limit (dB μ V)	Reading (dB μ V)	Result (dB)
0.20	0.16	0.19	H	63.82	49.00	49.35	53.82	30.91	31.26
0.26	0.16	0.20	H	61.50	52.31	52.67	51.50	32.29	32.65
0.32	0.16	0.20	H	59.68	43.60	43.96	49.68	25.14	25.50
0.39	0.16	0.21	H	58.06	35.96	36.33	48.06	19.85	20.22
0.59	0.16	0.21	H	56.00	33.97	34.35	46.00	21.98	22.36
0.65	0.17	0.22	H	56.00	34.13	34.51	46.00	24.15	24.53
Remark	H : Hot Line, N : Neutral Line *Correction Factor = Lisn + Cable *Result = Correction Factor + Reading								

Appendix 1. Special diagram

* HOT LINE



RBW 9 kHz
MT 1 s
Att 10 dB AUTO PREAMP OFF

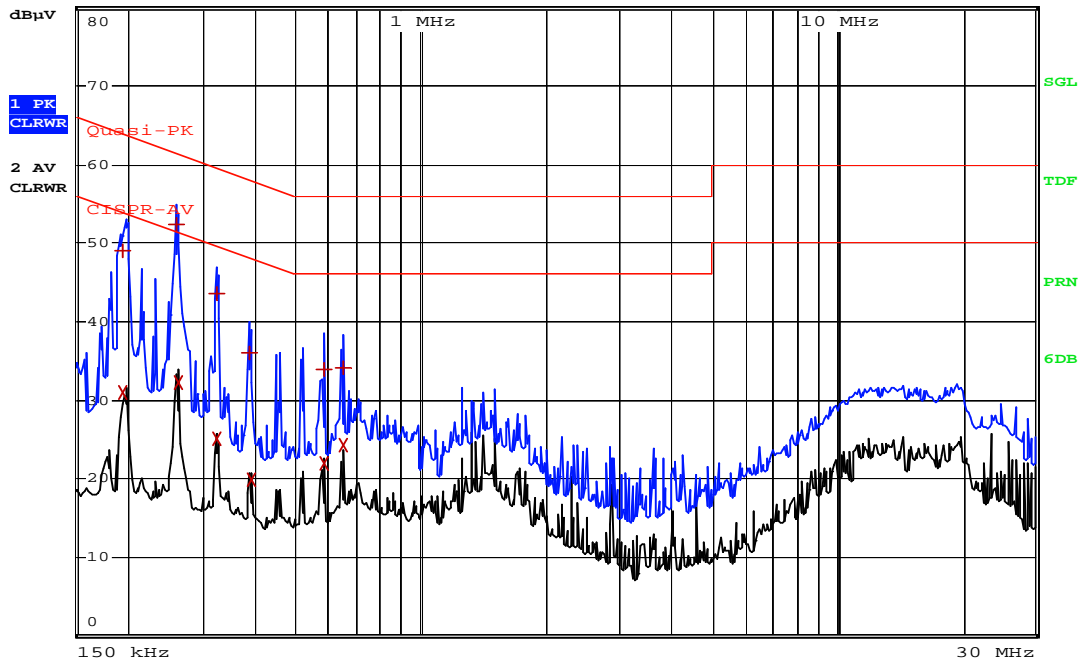

Comment: ESTR-17-07021_13.56M_HOT
Date: 20.JUL.2017 17:15:36

* NEUTRAL LINE



RBW 9 kHz
MT 1 s
Att 10 dB AUTO PREAMP OFF

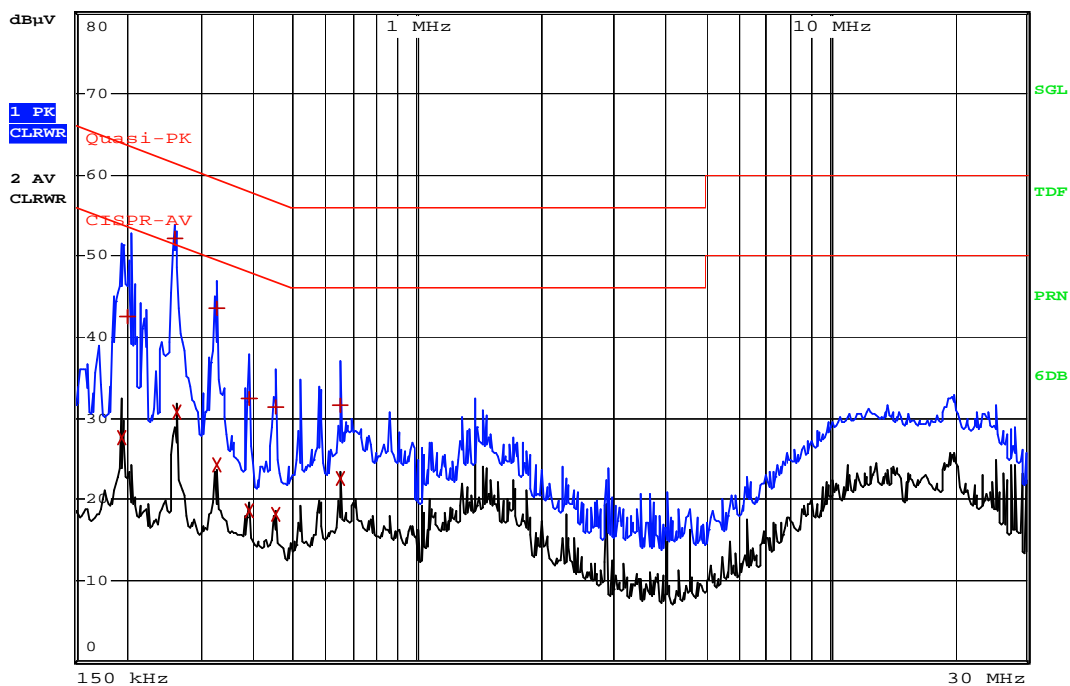

Comment: ESTR-17-07021_13.56M_NEUTRAL
Date: 20.JUL.2017 16:44:42

Appendix 1 . Antenna Requirement

Regulation

According to §15.203, an intentional radiator shall be designed to ensure that no antenna other than that furnished by the responsible party shall be used with the device. The use of a permanently attached antenna or of an antenna that uses a unique coupling to the intentional radiator shall be considered sufficient to comply with the provisions of this Section. The manufacturer may design the unit so that a broken antenna can be replaced by the user, but the use of a standard antenna jack or electrical connector is prohibited.

Result

-Complied

The transmitter has an PCB Patten Antenna.