

MEASUREMENT REPORT

FCC PART 15.407 WLAN 802.11a/n/ac

FCC ID: TK4WLE1216V520

APPLICANT: Compex Systems Pte Ltd

Application Type: Certification

Product: 4x4 Wave-2 802.11ac/a/n Mini PCIe WiFi Module

Model No.: WLE1216V5-20, WLE1216V5-20-I

Brand Name: COMPEX

FCC Classification: Unlicensed National Information Infrastructure (UNII)

FCC Rule Part(s): Part15 Subpart E (Section 15.407)

Test Procedure(s): ANSI C63.10-2013, KDB 789033 D02v01r04,
KDB 644545 D03v01, KDB 662911 D01v02r01

Test Date: October 25 ~ November 19, 2017

Reviewed By : *Jame Yuan*
(Jame Yuan)

Approved By : *Marlin Chen*
(Marlin Chen)



The test results relate only to the samples tested.

This equipment has been shown to be capable of compliance with the applicable technical standards as indicated in the measurement report and was tested in accordance with the measurement procedures specified in KDB 789033 D02v01r04. Test results reported herein relate only to the item(s) tested.

The test report shall not be reproduced except in full without the written approval of MRT Technology (Suzhou) Co., Ltd.

Revision History

Report No.	Version	Description	Issue Date	Note
1710RSU02001	Rev. 01	Initial Report	11-20-2017	Valid

CONTENTS

Description	Page
§2.1033 General Information	6
1. INTRODUCTION	7
1.1. Scope	7
1.2. MRT Test Location	7
2. PRODUCT INFORMATION	8
2.1. Equipment Description.....	8
2.2. Product Specification Subjective to this Report.....	8
2.3. Working Frequencies for this report	8
2.4. Description of Available Antennas	9
2.5. Description of Support Units	10
2.6. Description of Antenna RF Port	10
2.7. Test Mode	10
2.8. Description of Test Software	11
2.9. Device Capabilities	15
2.10. Test Configuration	17
2.11. EMI Suppression Device(s)/Modifications	17
2.12. Labeling Requirements.....	17
3. DESCRIPTION OF TEST	18
3.1. Evaluation Procedure	18
3.2. AC Line Conducted Emissions	18
3.3. Radiated Emissions	19
4. ANTENNA REQUIREMENTS.....	20
5. TEST EQUIPMENT CALIBRATION DATE	21
6. MEASUREMENT UNCERTAINTY.....	22
7. TEST RESULT	23
7.1. Summary	23
7.2. 26dB Bandwidth Measurement.....	24
7.2.1. Test Limit	24
7.2.2. Test Procedure Used	24
7.2.3. Test Setting.....	24
7.2.4. Test Setup	24
7.2.5. Test Result.....	25
7.3. 6dB Bandwidth Measurement.....	42

7.3.1. Test Limit	42
7.3.2. Test Procedure Used	42
7.3.3. Test Setting.....	42
7.3.4. Test Setup	42
7.3.5. Test Result.....	43
7.4. Output Power Measurement	48
7.4.1. Test Limit	48
7.4.2. Test Procedure Used	48
7.4.3. Test Setting.....	48
7.4.4. Test Setup	48
7.4.5. Test Result.....	49
7.5. Transmit Power Control	54
7.5.1. Test Limit	54
7.5.2. Test Procedure Used	54
7.5.3. Test Setting.....	54
7.5.4. Test Setup	54
7.5.5. Test Result.....	55
7.6. Power Spectral Density Measurement.....	58
7.6.1. Test Limit	58
7.6.2. Test Procedure Used	58
7.6.3. Test Setting.....	58
7.6.4. Test Setup	59
7.6.5. Test Result.....	60
7.7. Frequency Stability Measurement.....	126
7.7.1. Test Limit	126
7.7.2. Test Procedure Used	126
7.7.3. Test Setup	127
7.7.4. Test Result.....	128
7.8. Radiated Spurious Emission Measurement	129
7.8.1. Test Limit	129
7.8.2. Test Procedure Used	129
7.8.3. Test Setting.....	129
7.8.4. Test Setup	131
7.8.5. Test Result.....	133
7.9. Radiated Restricted Band Edge Measurement	259
7.9.1. Test Limit	259
7.9.2. Test Result.....	261
7.10. AC Conducted Emissions Measurement.....	499
7.10.1. Test Limit	499

7.10.2. Test Procedure	499
7.10.3. Test Setup	500
7.10.4. Test Result.....	501
8. CONCLUSION.....	503

§2.1033 General Information

Applicant:	Compex Systems Pte Ltd
Applicant Address:	No:9 Harrison Road, Harrison Industrial Building, #05-01, Singapore 369651
Manufacturer:	Compex Systems Pte Ltd
Manufacturer Address:	No:9 Harrison Road, Harrison Industrial Building, #05-01, Singapore 369651
Test Site:	MRT Technology (Suzhou) Co., Ltd
Test Site Address:	D8 Building, No.2 Tian'edang Rd., Wuzhong Economic Development Zone, Suzhou, China
FCC Registration No.:	893164
FCC Rule Part(s):	Part15 Subpart E (Section 15.407)
Model No.:	WLE1216V5-20, WLE1216V5-20-I
FCC ID:	TK4WLE1216V520
Test Device Serial No.:	N/A <input type="checkbox"/> Production <input checked="" type="checkbox"/> Pre-Production <input type="checkbox"/> Engineering

Test Facility / Accreditations

Measurements were performed at MRT Laboratory located in Tian'edang Rd., Suzhou, China.

- MRT facility is a FCC registered (MRT Reg. No. 893164) test facility with the site description report on file and has met all the requirements specified in Section 2.948 of the FCC Rules.
- MRT facility is an IC registered (MRT Reg. No. 11384A-1) test laboratory with the site description on file at Industry Canada.
- MRT facility is a VCCI registered (R-4179, G-814, C-4664, T-2206) test laboratory with the site description on file at VCCI Council.
- MRT Lab is accredited to ISO 17025 by the American Association for Laboratory Accreditation (A2LA) under the American Association for Laboratory Accreditation Program (A2LA Cert. No. 3628.01) in EMC, Telecommunications and Radio testing for FCC, Industry Canada, EU and TELEC Rules.



1. INTRODUCTION

1.1. Scope

Measurement and determination of electromagnetic emissions (EMC) of radio frequency devices including intentional and/or unintentional radiators for compliance with the technical rules and regulations of the Federal Communications Commission and the Industry Canada Certification and Engineering Bureau.

1.2. MRT Test Location

The map below shows the location of the MRT LABORATORY, its proximity to the Taihu Lake. These measurement tests were conducted at the MRT Technology (Suzhou) Co., Ltd. Facility located at D8 Building, No.2 Tian'edang Rd., Wuzhong Economic Development Zone, Suzhou, China. The detailed description of the measurement facility was found to be in compliance with the requirements of § 2.948 according to ANSI C63.4-2009 on September 30, 2013.



2. PRODUCT INFORMATION

2.1. Equipment Description

Product Name	4x4 Wave-2 802.11ac/a/n Mini PCIe WiFi Module
Model No.	WLE1216V5-20, WLE1216V5-20-I
Brand Name:	COMPEX
Wi-Fi Specification:	802.11a/b/g/n/ac
Operating Temperature:	-20 ~ 55 °C

Note: The difference between models is for different market sale.

2.2. Product Specification Subjective to this Report

Frequency Range	For 802.11a/n-HT20/ac-VHT20: 5180~5320MHz, 5500~5720MHz, 5745~5825MHz For 802.11n-HT40/ac-VHT40: 5190~5310MHz, 5510~5710MHz, 5755~5795MHz For 802.11ac-VHT80/ac-VHT80+80: 5210MHz, 5290MHz, 5530MHz, 5610MHz, 5690MHz, 5775MHz
Type of Modulation	802.11a/n/ac: OFDM
Data Rate	802.11a: 6/9/12/18/24/36/48/54Mbps 802.11n: up to 600Mbps 802.11ac: up to 1733.2Mbps

Note: For other features of this EUT, test report will be issued separately.

2.3. Working Frequencies for this report

802.11a/n-HT20/ac-VHT20

Channel	Frequency	Channel	Frequency	Channel	Frequency
36	5180 MHz	40	5200 MHz	44	5220 MHz
48	5240 MHz	52	5260 MHz	56	5280 MHz
60	5300 MHz	64	5320 MHz	100	5500 MHz
104	5520 MHz	108	5540 MHz	112	5560 MHz
116	5580 MHz	120	5600 MHz	124	5620 MHz
128	5640 MHz	132	5660 MHz	136	5680 MHz
140	5700 MHz	144	5720 MHz	149	5745 MHz
153	5765 MHz	157	5785 MHz	161	5805 MHz
165	5825 MHz	--	--	--	--

802.11n-HT40/ac-VHT40

Channel	Frequency	Channel	Frequency	Channel	Frequency
38	5190 MHz	46	5230 MHz	54	5270 MHz
62	5310 MHz	102	5510 MHz	110	5550 MHz
118	5590 MHz	126	5630 MHz	134	5670 MHz
142	5710 MHz	151	5755 MHz	159	5795 MHz

802.11ac-VHT80

Channel	Frequency	Channel	Frequency	Channel	Frequency
42	5210 MHz	58	5290 MHz	106	5530 MHz
122	5610 MHz	138	5690 MHz	155	5775 MHz

802.11ac-VHT80+80 Groups

5210MHz + 5530MHz	5210MHz + 5610MHz
5210MHz + 5690MHz	5210MHz + 5775MHz
5290MHz + 5530MHz	5290MHz + 5610MHz
5290MHz + 5690MHz	5290MHz + 5775MHz
5530MHz + 5775MHz	5610MHz + 5775MHz

2.4. Description of Available Antennas

No.	Antenna	Manufacturer	Frequency Band (MHz)	Max Peak Gain (dBi)
Wi-Fi External Antenna List (5GHz 4*4 MIMO)				
1#	Omni Directional	Exceltek Electronics Technology Co., Ltd.	2400 ~ 2500	3.0
			5150 ~ 5850	5.0
2#	Omni Directional	Laird Smart Technology Co., Ltd.	2400 ~ 2500	2.2
			5150 ~ 5850	3.5
3#	Omni Directional	Linx Technologies	2400 ~ 2500	2.5
			5150 ~ 5850	4.6
4#	Omni Directional	Kenbotong Technology Co., Ltd.	5150 ~ 5850	10.0

Note 1: The device didn't support beam-forming technology and Cyclic Delay Diversity (CDD) technology, and the transmit signals are uncorrected, so no add array gain to the band power and band PSD.

Note 2: We selected the max peak gain antenna 4# to perform all RF testing.

2.5. Description of Support Units

The EUT has been tested with associated equipment below:

Description	Manufacturer	Model No.
Client Terminal	Compex Systems Pte Ltd	WPJXXX

2.6. Description of Antenna RF Port

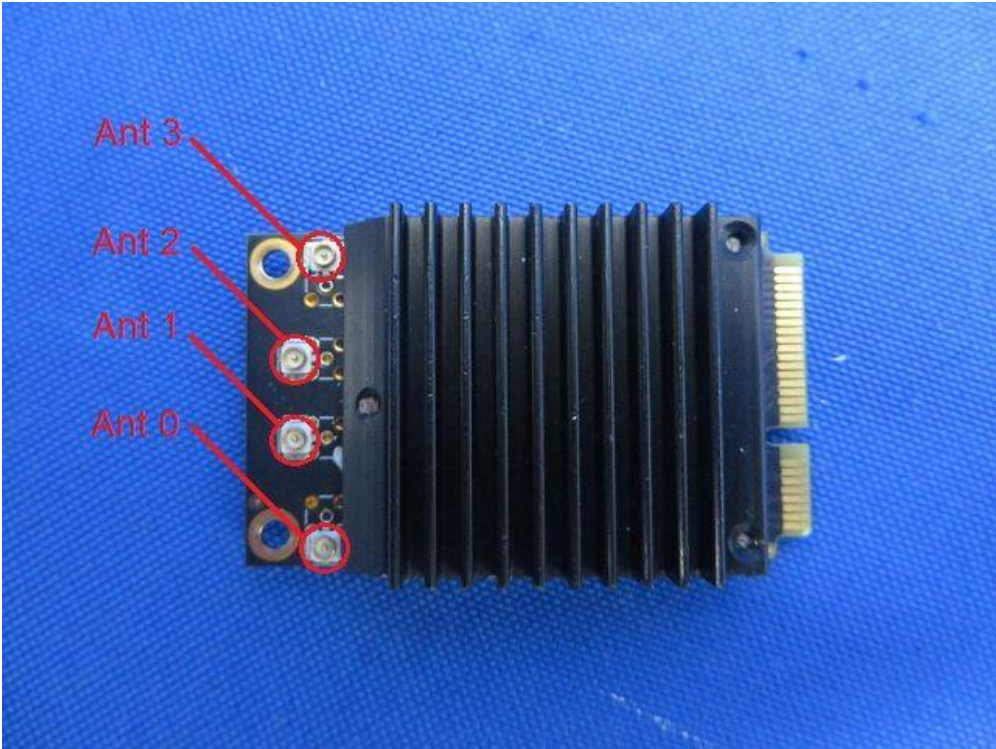
Antenna RF Port				
--	5GHz RF Port			
Software Control Port	Ant 0	Ant 1	Ant 2	Ant 3
				

2.7. Test Mode

Test Mode	Mode 1: Transmit by 802.11a
	Mode 2: Transmit by 802.11n-HT20
	Mode 3: Transmit by 802.11n-HT40
	Mode 4: Transmit by 802.11ac-VHT20
	Mode 5: Transmit by 802.11ac-VHT40
	Mode 6: Transmit by 802.11ac-VHT80
	Mode 7: Transmit by 802.11ac-VHT80+80

2.8. Description of Test Software

The test utility software used during testing was “QCARCT”, and the version was “v3.0.174.0”.

Power Parameter Value for 1TX

Test Mode	Channel No.	Test Frequency (MHz)	Power Parameter Value			
			Ant 0	Ant 1	Ant 2	Ant 3
802.11a	36	5180	17.0	17.0	17.5	17.5
	44	5220	17.5	17.5	17.5	17.5
	48	5240	18.0	17.5	17.5	18.0
	52	5260	17.0	17.0	17.0	17.5
	60	5300	17.0	17.0	17.0	17.5
	64	5320	17.0	17.0	17.0	17.5
	100	5500	17.0	16.5	16.5	17.0
	116	5580	17.0	16.5	16.0	16.5
	120	5600	17.0	16.5	16.5	16.5
	140	5700	17.5	16.5	16.5	17.0
	144	5720	17.5	16.5	16.5	17.0
	149	5745	21.0	21.0	21.0	21.0
	157	5785	21.0	21.0	21.0	21.0
	165	5825	21.0	21.0	21.0	21.0

Power Parameter Value for 4TX

Test Mode	Channel No.	Test Frequency (MHz)	Ant 0 + 1 + 2 + 3 Power Parameter Value
802.11 n-HT20	36	5180	11.5
	44	5220	12.0
	48	5240	12.0
	52	5260	11.0
	60	5300	11.0
	64	5320	11.0
	100	5500	10.5
	116	5580	10.0
	120	5600	10.5
	140	5700	10.5
	144	5720	10.5
	149	5745	18.5
	157	5785	18.0
	165	5825	18.0
802.11n-HT40	38	5190	13.5
	46	5230	13.5
	54	5270	14.0
	62	5310	14.0
	102	5510	13.5
	110	5550	14.0
	118	5590	14.0
	134	5670	13.5
	142	5710	13.5
	151	5755	19.5
	159	5795	20.0

Test Mode	Channel No.	Test Frequency (MHz)	Ant 0 + 1 + 2 + 3 Power Parameter Value
802.11ac-VHT20	36	5180	11.5
	44	5220	12.0
	48	5240	12.0
	52	5260	11.0
	60	5300	11.0
	64	5320	11.0
	100	5500	10.5
	116	5580	10.0
	120	5600	10.5
	140	5700	10.5
	144	5720	10.5
	149	5745	18.5
	157	5785	18.0
	165	5825	18.0
802.11ac-VHT40	38	5190	13.5
	46	5230	13.5
	54	5270	14.5
	62	5310	14.0
	102	5510	13.5
	110	5550	14.0
	118	5590	14.0
	134	5670	13.5
	142	5710	13.5
	151	5755	19.0
	159	5795	19.0
802.11ac-VHT80	42	5210	11.5
	58	5290	12.0
	106	5530	11.5
	122	5610	13.5
	138	5690	13.5
	155	5775	11.5

Test Mode	Channel No.	Test Freq. (MHz)	Power Parameter Value	
			Ant 0 + 1 / Ant 0 + 1 + 2 + 3	Ant 2 + 3 / Ant 0 + 1 + 2 + 3
Non-contiguous 80+80 MHz mode fall within different UNII band				
802.11ac-VHT80+80	42	5210	16.5	--
	42	5210	--	17.5
	58	5290	16.5	--
	58	5290	--	15.5
	106	5530	16.5	--
	106	5530	--	15.5
	122	5610	16.5	--
	122	5610	--	17.5
	138	5690	16.5	--
	138	5690	--	17.5
	155	5775	18.0	--
	155	5775	--	17.0

2.9. Device Capabilities

This device contains the following capabilities:

802.11a/n/ac Wi-Fi

Note: 5GHz (NII) operation is possible in 20MHz, 40MHz and 80MHz channel bandwidths. The maximum achievable duty cycles for all modes were determined based on measurements performed on a spectrum analyzer in zero-span mode with RBW = 8MHz, VBW = 50MHz, and detector = average per the guidance of Section B)2)b) of KDB 789033 D02v01r04. The RBW and VBW were both greater than 50/T, where T is the minimum transmission duration, and the number of sweep points across T was greater than 100. The duty cycles are as follows:

Test Mode	Duty Cycle
802.11a	97.04%
802.11n-HT20	98.68%
802.11n-HT40	97.71%
802.11ac-VHT20	98.68%
802.11ac-VHT40	97.44%
802.11ac-VHT80	95.03%
802.11ac-VHT80+80	95.03%

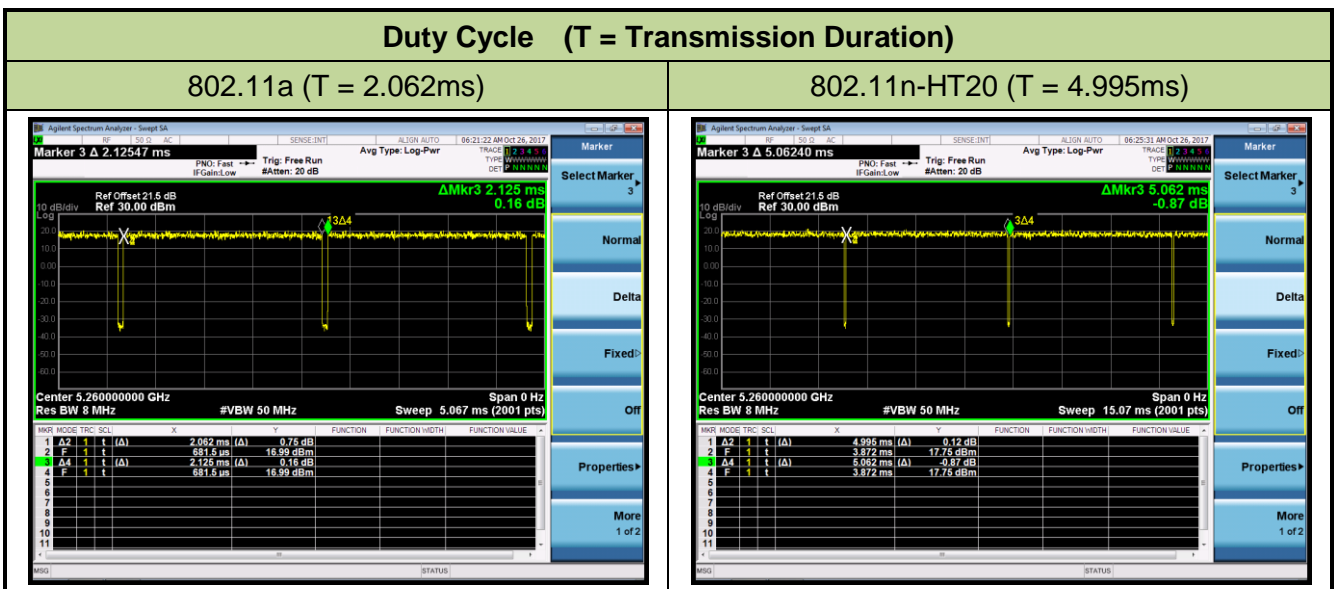

802.11n-HT40 (T = 2.428ms)

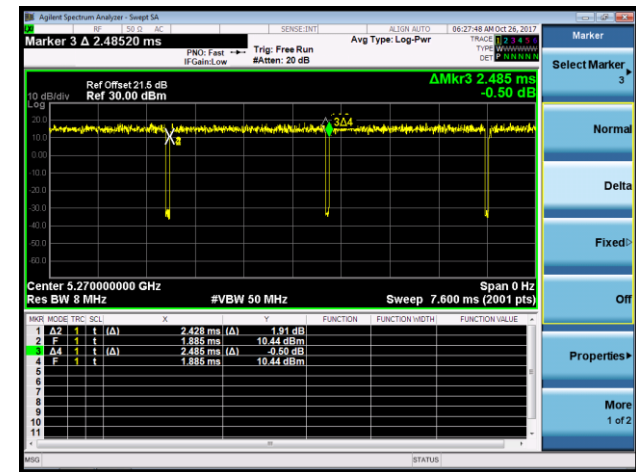

802.11ac-VHT20 (T = 5.010ms)

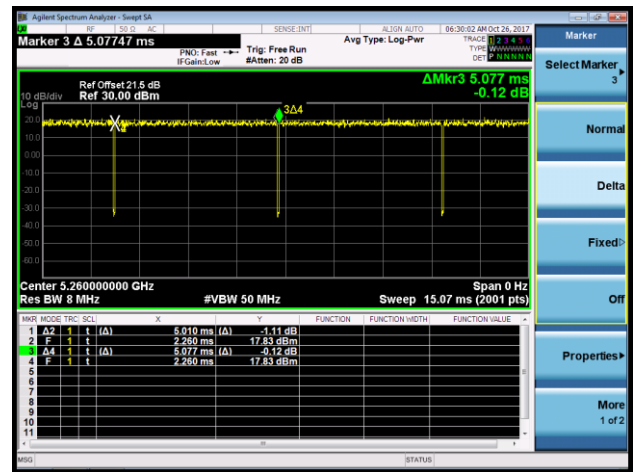

802.11ac-VHT40 (T = 2.436ms)

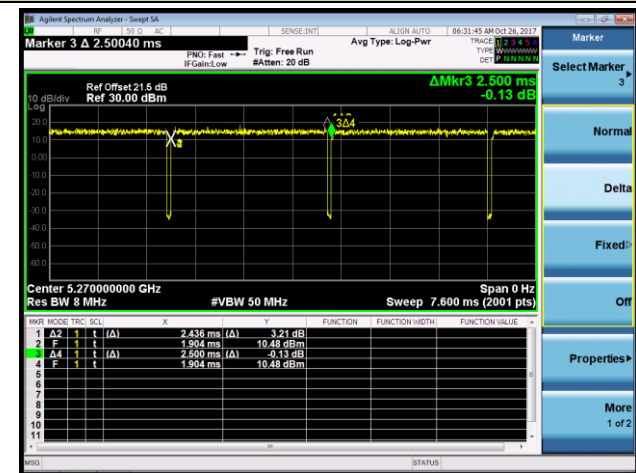

802.11ac-VHT80 (T = 1.148ms)

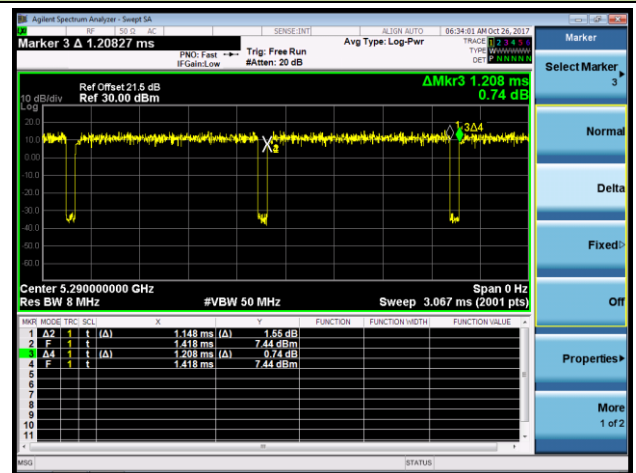

802.11ac-VHT80+80 (T = 1.148ms)

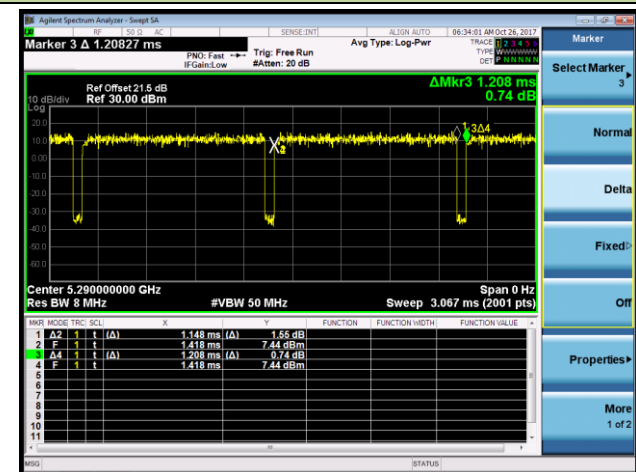

2.10. Test Configuration

The **4x4 Wave-2 802.11ac/a/n Mini PCIe WiFi Module** was tested per the guidance of KDB 789033 D02v01r04. ANSI C63.10-2013 was used to reference the appropriate EUT setup for radiated spurious emissions testing and AC line conducted testing.

2.11. EMI Suppression Device(s)/Modifications

No EMI suppression device(s) were added and/or no modifications were made during testing.

2.12. Labeling Requirements

Per 2.1074 & 15.19; Docket 95-19

The label shall be permanently affixed at a conspicuous location on the device; instruction manual or pamphlets supplied to the user and be readily visible to the purchaser at the time of purchase.

However, when the device is so small wherein placement of the label with specified statement is not practical, only the FCC ID must be displayed on the device per Section 15.19(a)(5). Please see attachment for FCC ID label and label location.

3. DESCRIPTION OF TEST

3.1. Evaluation Procedure

The measurement procedures described in the American National Standard for Testing Unlicensed Wireless Devices (ANSI C63.10-2013), and the guidance provided in KDB 789033 D02v01r04 were used in the measurement of the **4x4 Wave-2 802.11ac/a/n Mini PCIe WiFi Module**.

Deviation from measurement procedure.....None

3.2. AC Line Conducted Emissions

The line-conducted facility is located inside an 8'x4'x4' shielded enclosure. A 1m x 2m wooden table 80cm high is placed 40cm away from the vertical wall and 80cm away from the sidewall of the shielded room. Two 10kHz-30MHz, 50Ω/50uH Line-Impedance Stabilization Networks (LISNs) are bonded to the shielded room floor. Power to the LISNs is filtered by external high-current high-insertion loss power line filters. These filters attenuate ambient signal noise from entering the measurement lines. These filters are also bonded to the shielded enclosure.

The EUT is powered from one LISN and the support equipment is powered from the second LISN. All interconnecting cables more than 1 meter were shortened to a 1 meter length by non-inductive bundling (serpentine fashion) and draped over the back edge of the test table. All cables were at least 40cm above the horizontal reference ground-plane. Power cables for support equipment were routed down to the second LISN while ensuring that that cables were not draped over the second LISN.

Sufficient time for the EUT, support equipment, and test equipment was allowed in order for them to warm up to their normal operating condition. The RF output of the LISN was connected to the receiver and exploratory measurements were made to determine the frequencies producing the maximum emission from the EUT. The receiver was scanned from 150kHz to 30MHz. The detector function was set to peak mode for exploratory measurements while the bandwidth of the analyzer was set to 9kHz. The EUT, support equipment, and interconnecting cables were arranged and manipulated to maximize each emission. Each emission was also maximized by varying: power lines, the mode of operation or data exchange speed, or support equipment whichever determined the worst-case emission. Once the worst case emissions have been identified, the one EUT cable configuration/arrangement and mode of operation that produced these emissions are used for final measurements on the same test site. The analyzer is set to CISPR quasi-peak and average detectors with a 9kHz resolution bandwidth for final measurements.

An extension cord was used to connect to a single LISN which powered by EUT. The extension cord was calibrated with LISN, the impedance and insertion loss are compliance with the requirements as stated in ANSI C63.10-2013.

Line conducted emissions test results are shown in Section 7.10.

3.3. Radiated Emissions

The radiated test facilities consisted of an indoor 3 meter semi-anechoic chamber used for final measurements and exploratory measurements, when necessary. The measurement area is contained within the semi-anechoic chamber which is shielded from any ambient interference. For measurements above 1GHz absorbers are arranged on the floor between the turn table and the antenna mast in such a way so as to maximize the reduction of reflections. For measurements below 1GHz, the absorbers are removed. A MF Model 210SS turntable is used for radiated measurement. It is a continuously rotatable, remotecontrolled, metallic turntable and 2 meters (6.56 ft.) in diameter. The turn table is flush with the raised floor of the chamber in order to maintain its function as a ground plane. An 80cm high PVC support structure is placed on top of the turntable.

For all measurements, the spectrum was scanned through all EUT azimuths and from 1 to 4 meter receive antenna height using a broadband antenna from 30MHz up to the upper frequency shown in 15.33(b)(1) depending on the highest frequency generated or used in the device or on which the device operates or tunes. For frequencies above 1GHz, linearly polarized double ridge horn antennas were used. For frequencies below 30MHz, a calibrated loop antenna was used. When exploratory measurements were necessary, they were performed at 1 meter test distance inside the semi-anechoic chamber using broadband antennas, broadband amplifiers, and spectrum analyzers to determine the frequencies and modes producing the maximum emissions. Sufficient time for the EUT, support equipment, and test equipment was allowed in order for them to warm up to their normal operating condition. The test set-up for frequencies below 1GHz was placed on top of the 0.8 meter high, 1 x 1.5 meter table; and test set-up for frequencies 1-40GHz was placed on top of the 1.5 meter high, 1 x 1.5 meter table. The EUT, support equipment, and interconnecting cables were arranged and manipulated to maximize each emission. Appropriate precaution was taken to ensure that all emissions from the EUT were maximized and investigated. The system configuration, clock speed, mode of operation or video resolution, if applicable, turntable azimuth, and receive antenna height was noted for each frequency found.

Final measurements were made in the semi-anechoic chamber using calibrated, linearly polarized broadband and horn antennas. The test setup was configured to the setup that produced the worst case emissions. The spectrum analyzer was set to investigate all frequencies required for testing to compare the highest radiated disturbances with respect to the specified limits. The turntable containing the EUT was rotated through 360 degrees and the height of the receive antenna was varied 1 to 4 meters and stopped at the azimuth and height producing the maximum emission. Each emission was maximized by changing the orientation of the EUT through three orthogonal planes and changing the polarity of the receive antenna, whichever produced the worst-case emissions. According to 3dB Beam-Width of horn antenna, the horn antenna should be always directed to the EUT when rising height.

4. ANTENNA REQUIREMENTS

Excerpt from §15.203 of the FCC Rules/Regulations:

“An intentional radiator antenna shall be designed to ensure that no antenna other than that furnished by the responsible party can be used with the device. The use of a permanently attached antenna or of an antenna that uses a unique coupling to the intentional radiator shall be considered sufficient to comply with the provisions of this section.”

- The antenna of the **4x4 Wave-2 802.11ac/a/n Mini PCIe WiFi Module** uses a unique connector.

Antenna Type	Antenna Connector Type
Dipole Antenna 1#	Reversed SMA connector
Dipole Antenna 2#	Reversed SMA connector
Dipole Antenna 3#	Reversed SMA connector
Dipole Antenna 4#	Reversed N-Type connector

Conclusion:

This **4x4 Wave-2 802.11ac/a/n Mini PCIe WiFi Module** unit complies with the requirement of §15.203.

5. TEST EQUIPMENT CALIBRATION DATE

Conducted Emissions - SR2

Instrument	Manufacturer	Type No.	Asset No.	Cali. Interval	Cali. Due Date
EMI Test Receiver	R&S	ESR3	MRTSUE06185	1 year	2018/04/25
Two-Line V-Network	R&S	ENV216	MRTSUE06002	1 year	2018/06/20
Two-Line V-Network	R&S	ENV216	MRTSUE06003	1 year	2018/06/20
Temperature/Humidity Meter	Yuhuaze	HTC-2	MRTSUE06181	1 year	2017/12/20
Shielding Anechoic Chamber	Mikebang	Chamber-SR2	MRTSUE06214	1 year	2018/05/10

Radiated Emissions - AC1

Instrument	Manufacturer	Type No.	Asset No.	Cali. Interval	Cali. Due Date
MXE EMI Receiver	Agilent	N9038A	MRTSUE06125	1 year	2018/08/03
Microwave System Amplifier	Agilent	83017A	MRTSUE06076	1 year	2018/03/28
Loop Antenna	Schwarzbeck	FMZB1519	MRTSUE06025	1 year	2017/11/21
				1 year	2018/11/21
Bilog Period Antenna	Schwarzbeck	VULB 9168	MRTSUE06172	1 year	2017/11/19
				1 year	2018/11/19
Horn Antenna	Schwarzbeck	BBHA9120D	MRTSUE06023	1 year	2018/10/21
Broadband Horn Antenna	Schwarzbeck	BBHA9170	MRTSUE06024	1 year	2018/01/04
Temperature/Humidity Meter	Yuhuaze	HTC-2	MRTSUE06183	1 year	2017/12/20
Anechoic Chamber	TDK	Chamber-AC1	MRTSUE06212	1 year	2018/05/10

Conducted Test Equipment - TR3

Instrument	Manufacturer	Type No.	Asset No.	Cali. Interval	Cali. Due Date
Power Meter	Agilent	U2021XA	MRTSUE06030	1 year	2017/12/06
EXA Signal Analyzer	Agilent	N9020A	MRTSUE06106	1 year	2018/04/25
Temperature/Humidity Meter	Yuhuaze	HTC-2	MRTSUE06180	1 year	2017/12/20

Software	Version	Function
e3	V 8.3.5	EMI Test Software

6. MEASUREMENT UNCERTAINTY

Where relevant, the following test uncertainty levels have been estimated for tests performed on the EUT as specified in CISPR 16-4-2. This uncertainty represents an expanded uncertainty expressed at approximately the 95% confidence level using a coverage factor of $k = 2$.

AC Conducted Emission Measurement - SR2
Measuring Uncertainty for a Level of Confidence of 95% ($U=2Uc(y)$): 150kHz~30MHz: 3.46dB
Radiated Emission Measurement - AC2
Measuring Uncertainty for a Level of Confidence of 95% ($U=2Uc(y)$): 9kHz ~ 1GHz: 4.18dB 1GHz ~ 25GHz: 4.76dB
Spurious Emissions, Conducted - TR3
Measuring Uncertainty for a Level of Confidence of 95% ($U=2Uc(y)$): 0.78dB
Output Power - TR3
Measuring Uncertainty for a Level of Confidence of 95% ($U=2Uc(y)$): 1.13dB
Power Spectrum Density - TR3
Measuring Uncertainty for a Level of Confidence of 95% ($U=2Uc(y)$): 1.15dB
Occupied Bandwidth - TR3
Measuring Uncertainty for a Level of Confidence of 95% ($U=2Uc(y)$): 0.28%

7. TEST RESULT

7.1. Summary

Product Name: 4x4 Wave-2 802.11ac/a/n Mini PCIe WiFi Module
FCC ID: TK4WLE1216V520
FCC Classification: Unlicensed National Information Infrastructure (UNII)
Data Rate / MCS 6Mbps ~ 54Mbps (a); MCS0 for 802.11n-HT20MHz;
Tested: MCS0 for 802.11n-HT40MHz; MCS0 for 802.11ac-VHT20MHz;
MCS0 for 802.11ac-VHT40MHz; MCS0 for 802.11ac-VHT80MHz;
MCS0 for 802.11ac-VHT80+80MHz.

FCC Section(s)	Test Description	Test Limit	Test Condition	Test Result	Reference
15.407(a)	26dB Bandwidth	N/A	Conducted	Pass	Section 7.2
15.407(e)	6dB Bandwidth	≥ 500kHz		Pass	Section 7.3
15.407(a)(1)(iv), (2), (3)	Maximum Conducted Output Power	Refer to Section 7.4		Pass	Section 7.4
15.407(h)(1)	Transmit Power Control	≤ 24 dBm		Pass	Section 7.5
15.407(a)(1)(iv), (2), (3), (5)	Peak Power Spectral Density	Refer to Section 7.6		Pass	Section 7.6
15.407(g)	Frequency Stability	N/A		Pass	Section 7.7
15.407(b)(1), (2), (3), (4)(i)	Undesirable Emissions	Refer to Section 7.8 & 7.9	Radiated	Pass	Section 7.8 & 7.9
15.205, 15.209 15.407(b)(5), (6), (7)	General Field Strength Limits (Restricted Bands and Radiated Emission Limits)	Emissions in restricted bands must meet the radiated limits detailed in 15.209		Pass	
15.207	AC Conducted Emissions 150kHz - 30MHz	< FCC 15.207 limits	Line Conducted	Pass	Section 7.10

Notes:

- 1) The analyzer plots shown in this section were all taken with a correction table loaded into the analyzer. The correction table was used to account for the losses of the cables and attenuators used as part of the system to connect the EUT to the analyzer at all frequencies of interest.
- 2) Test Items "26dB Bandwidth" & "99% Bandwidth" & "6dB Bandwidth" have been assessed single and MIMO transmission, and showed the worst test data in this report.

7.2. 26dB Bandwidth Measurement

7.2.1. Test Limit

N/A

7.2.2. Test Procedure Used

KDB 789033 D02v01r04 - Section C.1

7.2.3. Test Setting

1. The analyzers' automatic bandwidth measurement capability was used to perform the 26dB bandwidth measurement. The "X" dB bandwidth parameter was set to $X = 26$. The automatic bandwidth measurement function also has the capability of simultaneously measuring the 99% occupied bandwidth. The bandwidth measurement was not influenced by any intermediated power nulls in the fundamental emission.
2. RBW = approximately 1% of the emission bandwidth.
3. VBW $\geq 3 \times$ RBW.
4. Detector = Peak.
5. Trace mode = max hold.

7.2.4. Test Setup

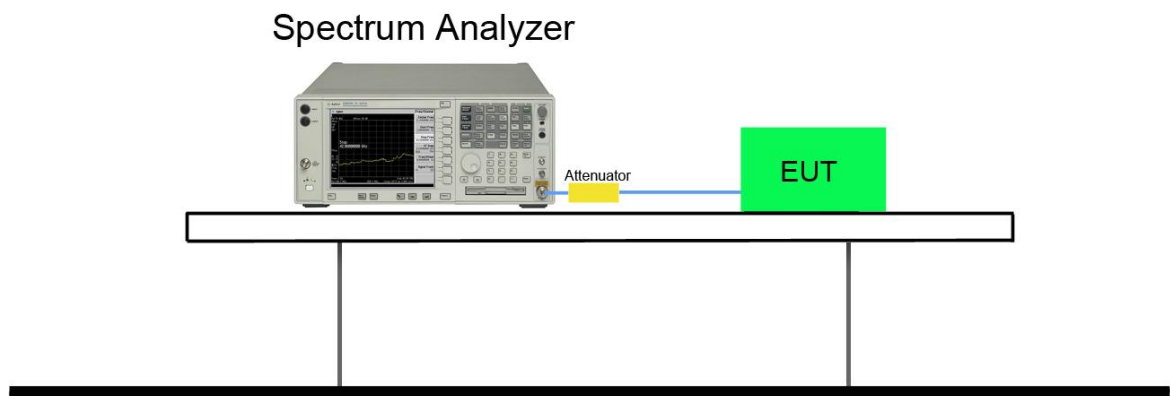

7.2.5. Test Result

Product	4x4 Wave-2 802.11ac/a/n Mini PCIe WiFi Module	Temperature	24°C
Test Engineer	Amy Zhang	Relative Humidity	58%
Test Site	SR2	Test Date	2017/11/04

Test Mode	Data Rate/MCS	Channel No.	Frequency (MHz)	26dB Bandwidth (MHz)	99% Bandwidth (MHz)
Ant 1					
802.11a	6Mbps	36	5180	19.81	16.44
802.11a	6Mbps	44	5220	21.35	16.53
802.11a	6Mbps	48	5240	21.47	16.50
802.11a	6Mbps	52	5260	19.57	16.44
802.11a	6Mbps	60	5300	19.40	16.41
802.11a	6Mbps	64	5320	19.55	16.42
802.11a	6Mbps	100	5500	19.14	16.42
802.11a	6Mbps	116	5580	19.79	16.43
802.11a	6Mbps	120	5600	19.24	16.43
802.11a	6Mbps	140	5700	19.37	16.45
802.11a	6Mbps	144	5720	19.54	16.42
802.11a	6Mbps	149	5745	19.46	16.41
802.11a	6Mbps	157	5785	19.51	19.41
802.11a	6Mbps	165	5825	19.46	16.40

Ant 1 / Ant 0 + 1 + 2 + 3					
802.11n-HT20	MCS0	36	5180	20.13	17.60
802.11n-HT20	MCS0	44	5220	21.19	16.67
802.11n-HT20	MCS0	48	5240	21.83	16.55
802.11n-HT20	MCS0	52	5260	20.19	17.60
802.11n-HT20	MCS0	60	5300	20.27	17.60
802.11n-HT20	MCS0	64	5320	19.98	17.59
802.11n-HT20	MCS0	100	5500	20.10	17.59
802.11n-HT20	MCS0	116	5580	20.14	17.64
802.11n-HT20	MCS0	120	5600	20.24	17.61
802.11n-HT20	MCS0	140	5700	20.26	17.61
802.11n-HT20	MCS0	144	5720	20.10	17.61
802.11n-HT20	MCS0	149	5745	20.02	17.58
802.11n-HT20	MCS0	157	5785	20.17	17.57
802.11n-HT20	MCS0	165	5825	20.27	17.58
802.11n-HT40	MCS0	38	5190	39.37	35.90
802.11n-HT40	MCS0	46	5230	39.39	35.98
802.11n-HT40	MCS0	54	5270	39.81	36.01
802.11n-HT40	MCS0	62	5310	39.22	35.93
802.11n-HT40	MCS0	102	5510	39.39	35.95
802.11n-HT40	MCS0	110	5550	39.65	35.95
802.11n-HT40	MCS0	118	5590	39.59	36.06
802.11n-HT40	MCS0	134	5670	39.20	35.95
802.11n-HT40	MCS0	142	5710	39.46	35.99
802.11n-HT40	MCS0	151	5755	39.37	35.93
802.11n-HT40	MCS0	159	5795	39.55	35.85
802.11ac-VHT20	MCS0	36	5180	20.11	17.61
802.11ac-VHT20	MCS0	44	5220	20.50	17.64
802.11ac-VHT20	MCS0	48	5240	21.26	17.68
802.11ac-VHT20	MCS0	52	5260	20.14	17.61
802.11ac-VHT20	MCS0	60	5300	19.92	17.60
802.11ac-VHT20	MCS0	64	5320	20.20	17.62
802.11ac-VHT20	MCS0	100	5500	20.16	17.61
802.11ac-VHT20	MCS0	116	5580	20.03	17.60
802.11ac-VHT20	MCS0	120	5600	20.29	17.63
802.11ac-VHT20	MCS0	140	5700	20.22	17.61

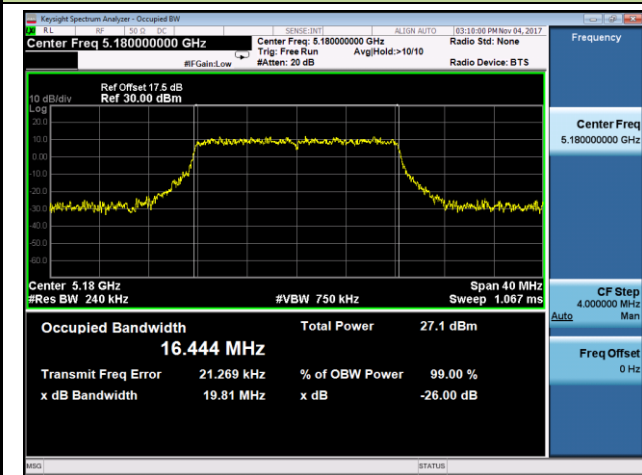
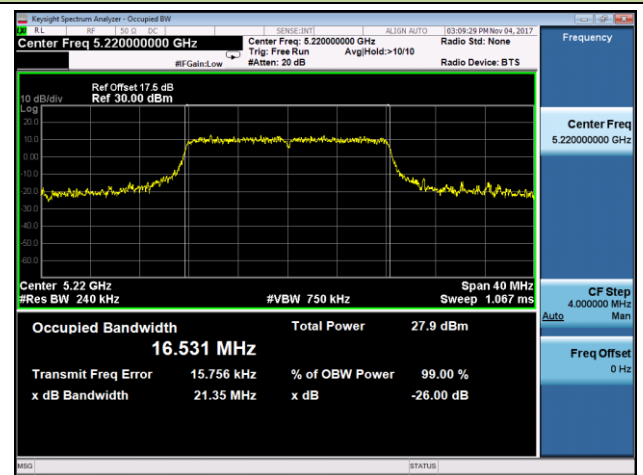
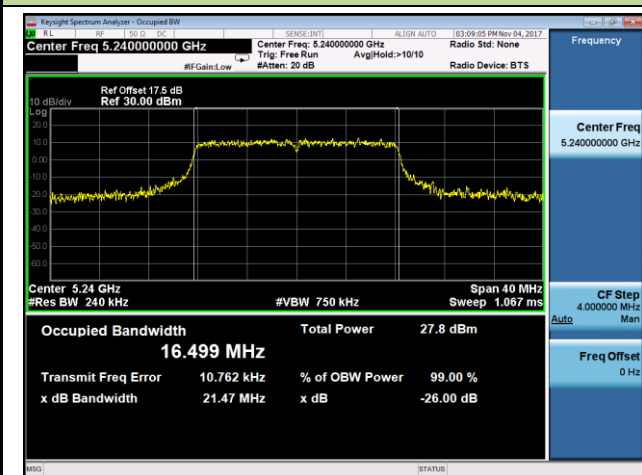
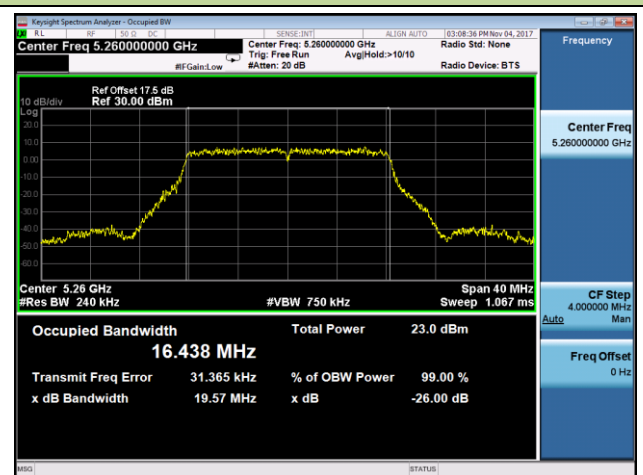
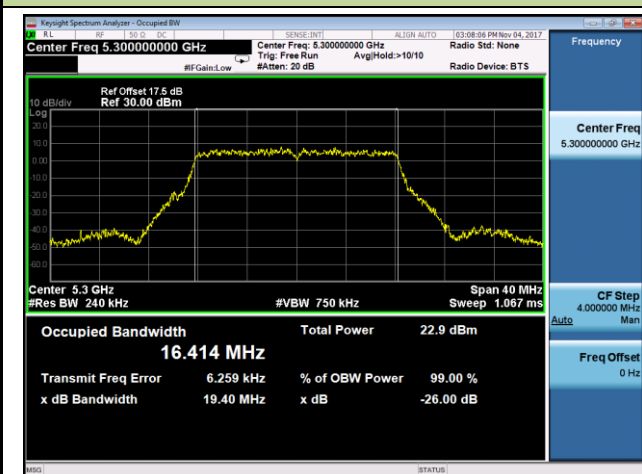
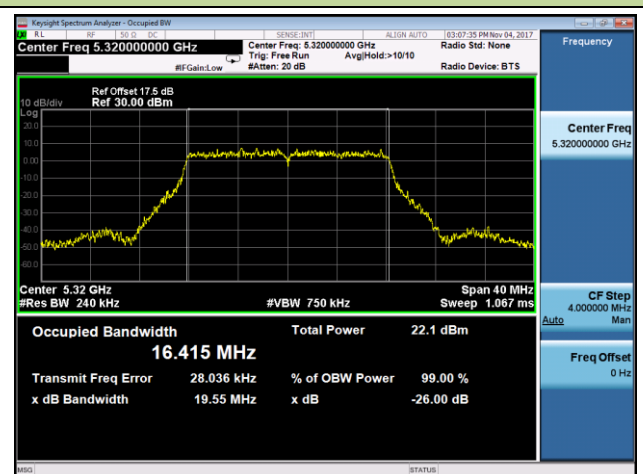

802.11ac-VHT20	MCS0	144	5720	20.01	17.60
802.11ac-VHT20	MCS0	149	5745	20.20	17.59
802.11ac-VHT20	MCS0	157	5785	20.01	17.59
802.11ac-VHT20	MCS0	165	5825	20.19	17.59
802.11ac-VHT40	MCS0	38	5190	39.46	35.88
802.11ac-VHT40	MCS0	46	5230	39.20	36.03
802.11ac-VHT40	MCS0	54	5270	46.36	36.04
802.11ac-VHT40	MCS0	62	5310	38.99	35.95
802.11ac-VHT40	MCS0	102	5510	39.30	35.91
802.11ac-VHT40	MCS0	110	5550	39.06	35.93
802.11ac-VHT40	MCS0	118	5590	39.81	36.03
802.11ac-VHT40	MCS0	134	5670	39.16	35.97
802.11ac-VHT40	MCS0	142	5710	43.61	36.14
802.11ac-VHT40	MCS0	151	5755	39.52	35.90
802.11ac-VHT40	MCS0	159	5795	39.47	35.88
802.11ac-VHT80	MCS0	42	5210	82.68	75.81
802.11ac-VHT80	MCS0	58	5290	82.87	75.85
802.11ac-VHT80	MCS0	106	5530	81.77	75.69
802.11ac-VHT80	MCS0	122	5610	83.59	75.92
802.11ac-VHT80	MCS0	138	5690	83.48	75.81
802.11ac-VHT80	MCS0	155	5775	83.46	76.07

802.11a 26dB Bandwidth & 99% Bandwidth - Ant 1
Channel 36 (5180MHz)

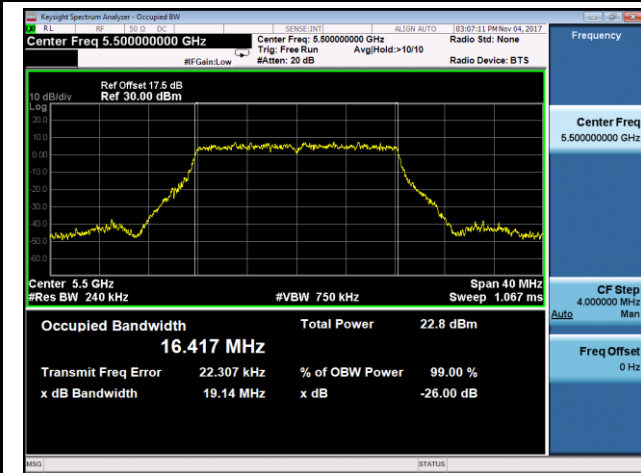
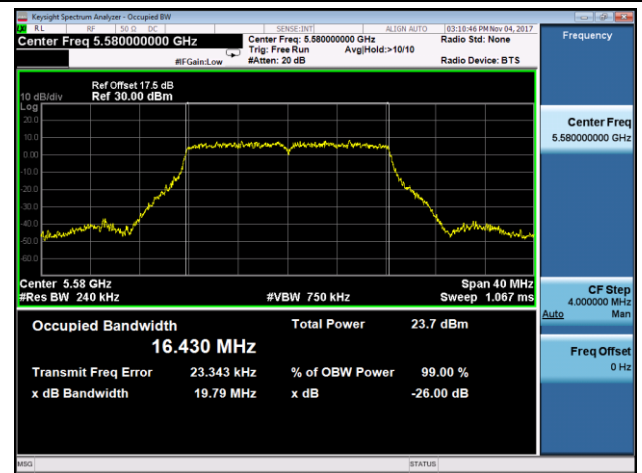
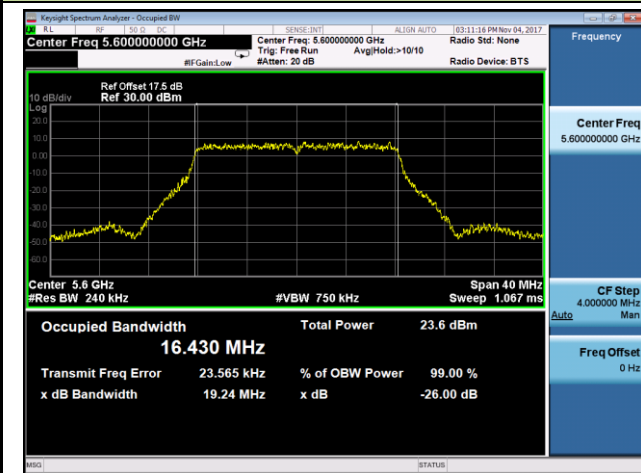
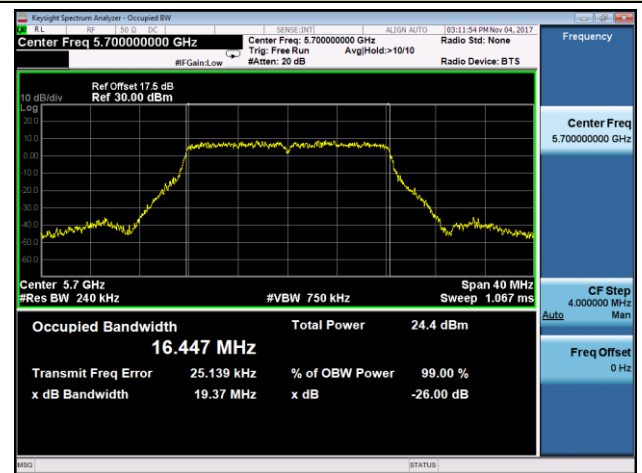
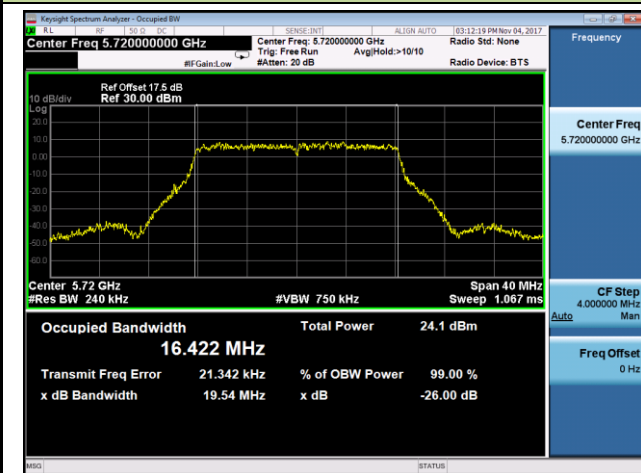
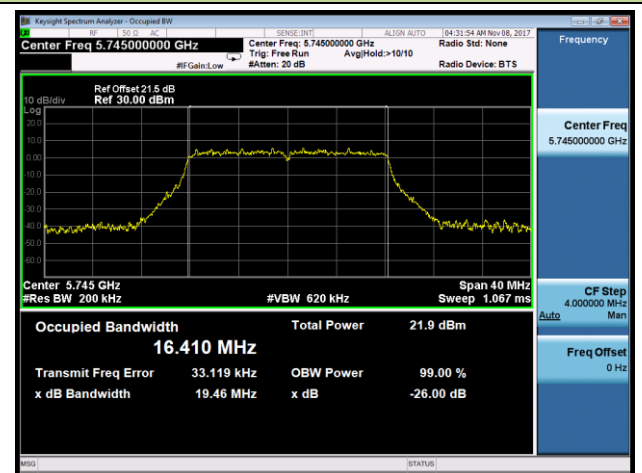
Channel 44 (5220MHz)

Channel 48 (5240MHz)

Channel 52 (5260MHz)

Channel 60 (5300MHz)

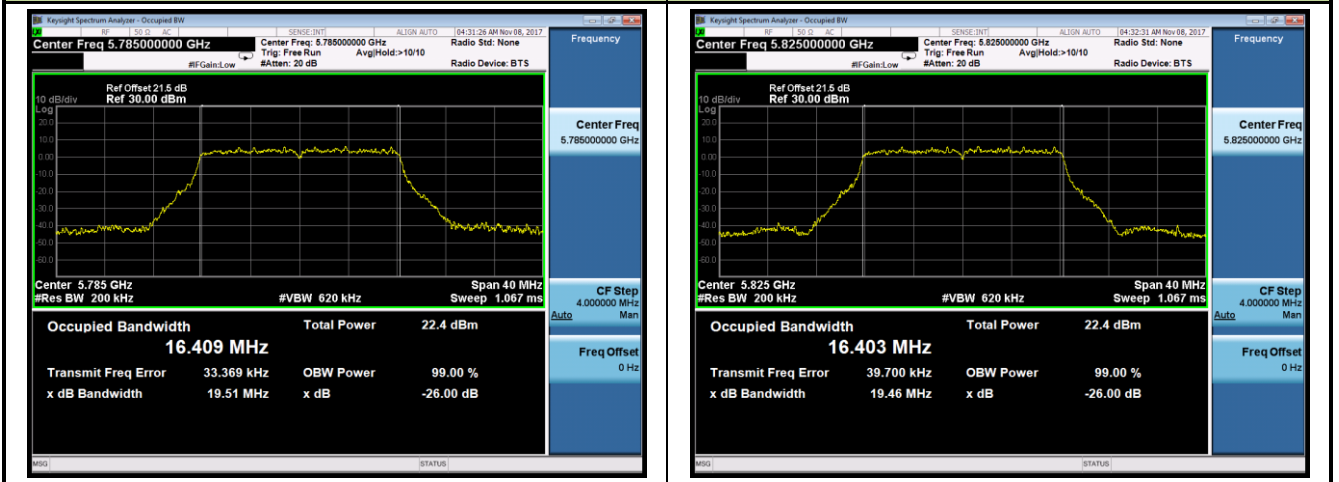
Channel 64 (5320MHz)

802.11a 26dB Bandwidth & 99% Bandwidth - Ant 1
Channel 100 (5500MHz)

Channel 116 (5580MHz)

Channel 100 (5600MHz)

Channel 140 (5700MHz)

Channel 144 (5720MHz)

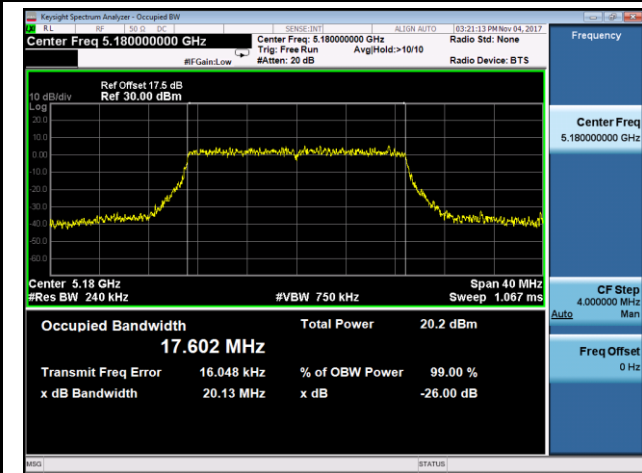
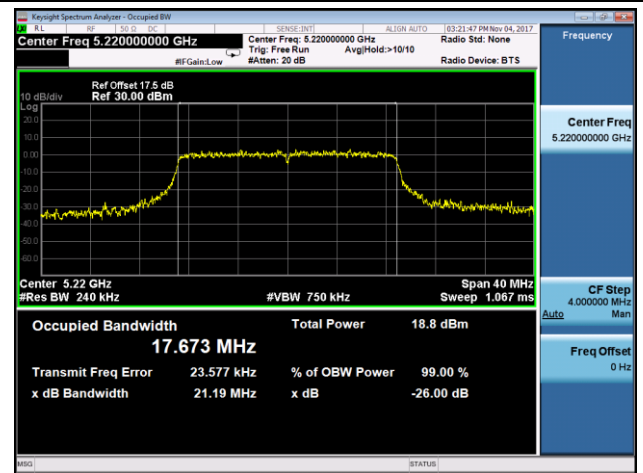
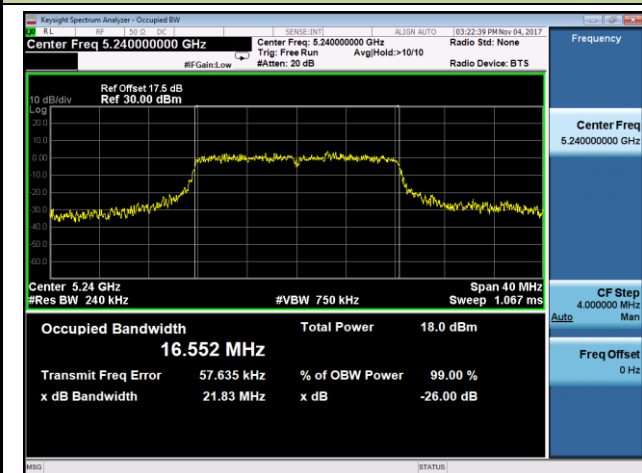
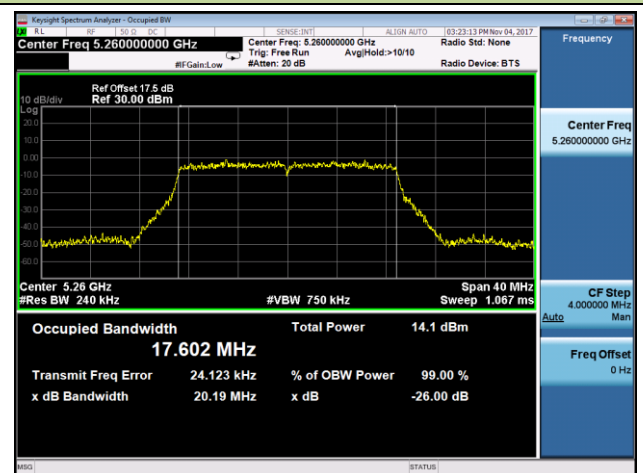
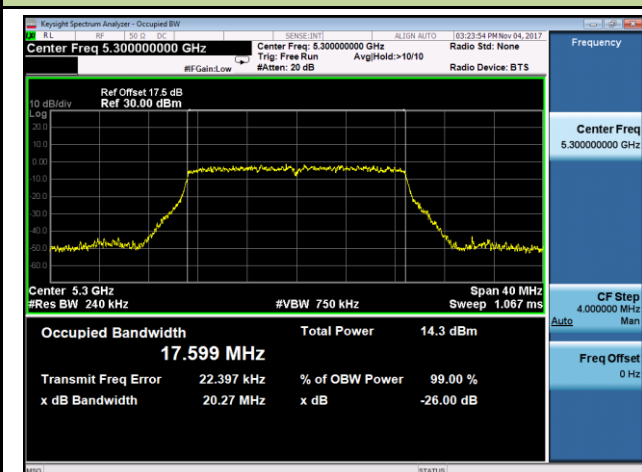
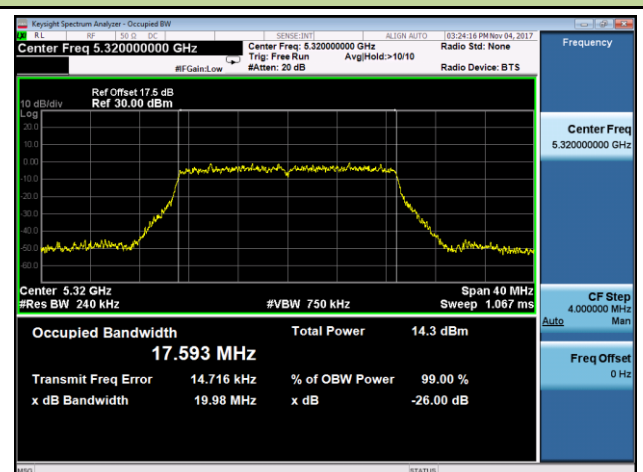
Channel 149 (5745MHz)

802.11a 26dB Bandwidth & 99% Bandwidth - Ant 1

Channel 157 (5785MHz)

Channel 165 (5825MHz)



802.11n-HT20 26dB Bandwidth & 99% Bandwidth - Ant 1 / Ant 0 + 1 + 2 + 3
Channel 36 (5180MHz)

Channel 44 (5220MHz)

Channel 48 (5240MHz)

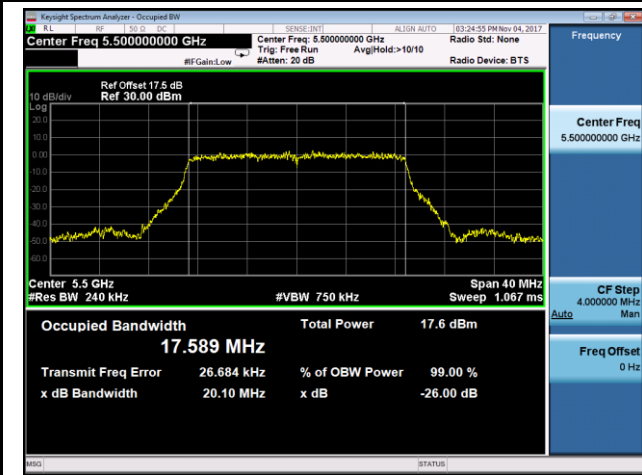
Channel 52 (5260MHz)

Channel 60 (5300MHz)

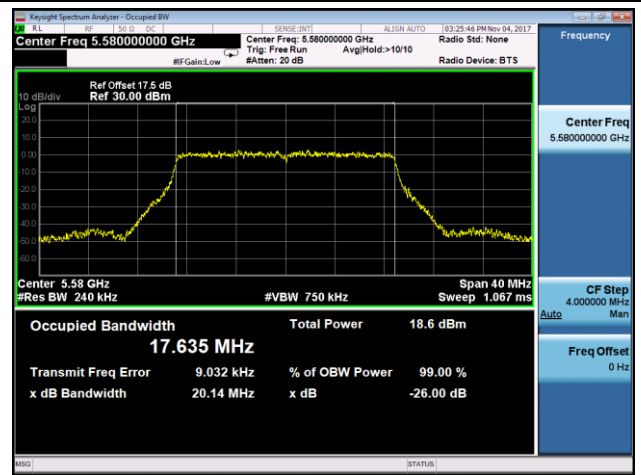
Channel 64 (5320MHz)

802.11n-HT20 26dB Bandwidth & 99% Bandwidth - Ant 1 / Ant 0 + 1 + 2 + 3

Channel 100 (5500MHz)



Channel 116 (5580MHz)



Channel 120 (5600MHz)

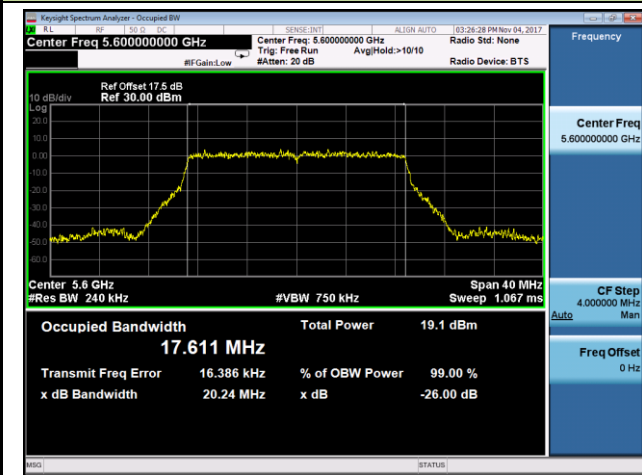

Channel 140 (5700MHz)

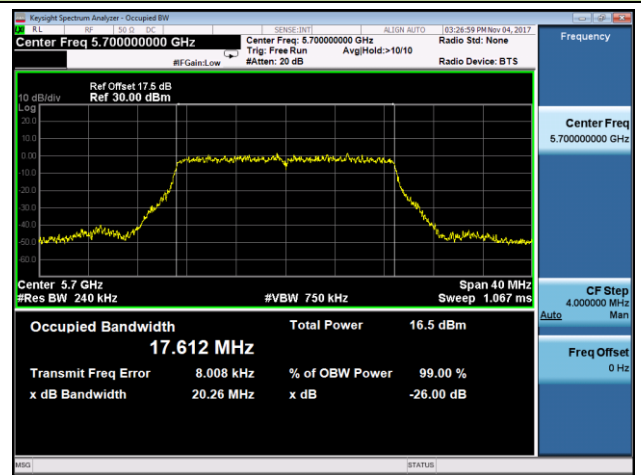

Channel 144 (5720MHz)

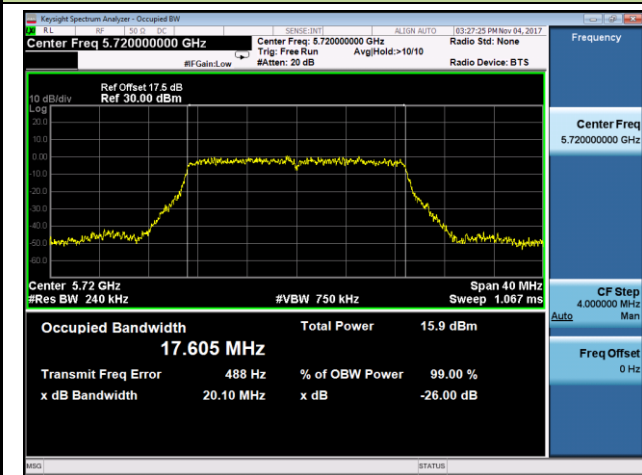

Channel 149 (5745MHz)

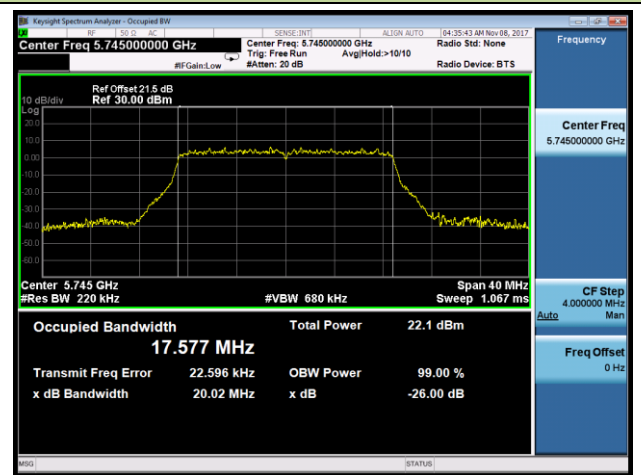

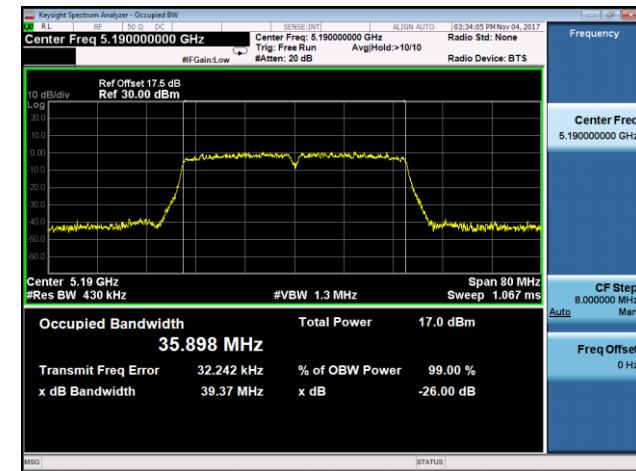
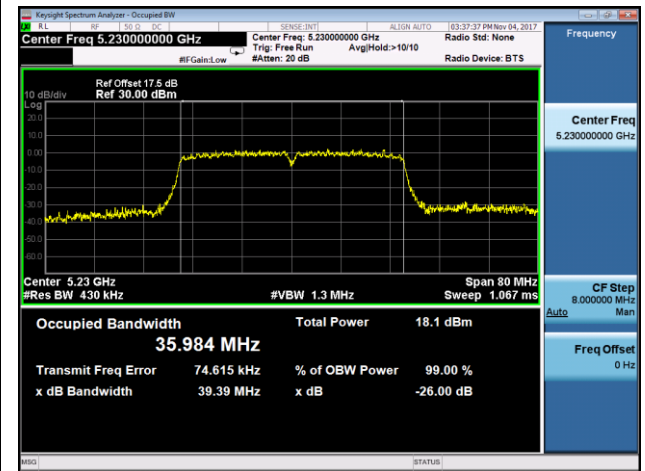
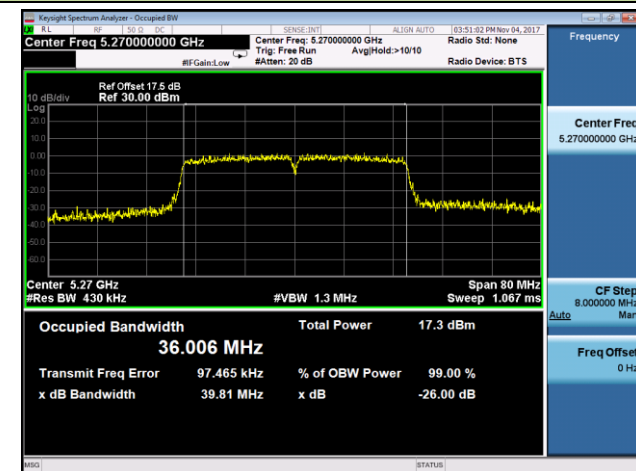
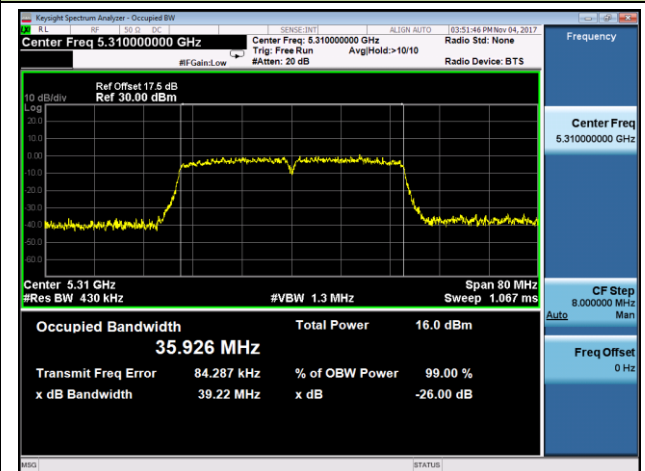
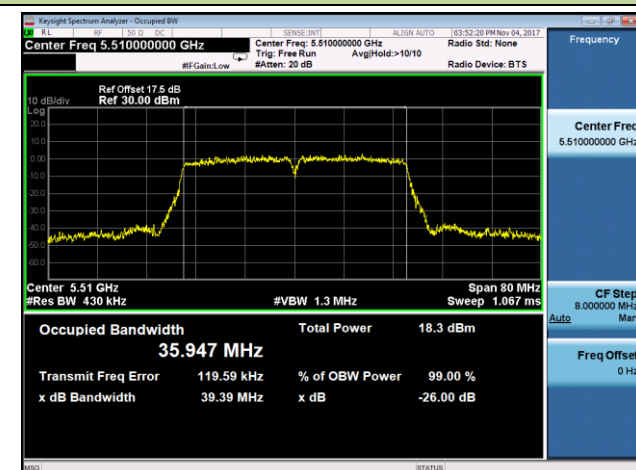
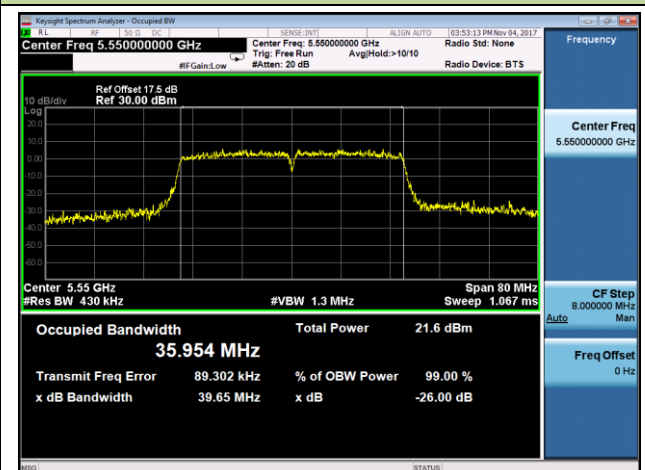
802.11n-HT40 26dB Bandwidth & 99% Bandwidth - Ant 1 / Ant 0 + 1 + 2 + 3
Channel 38 (5190MHz)

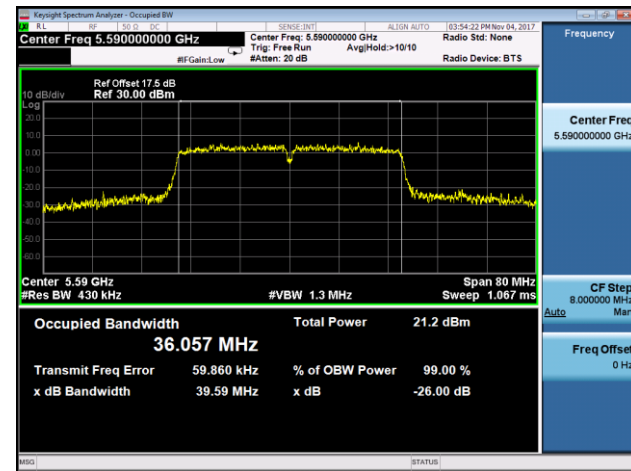
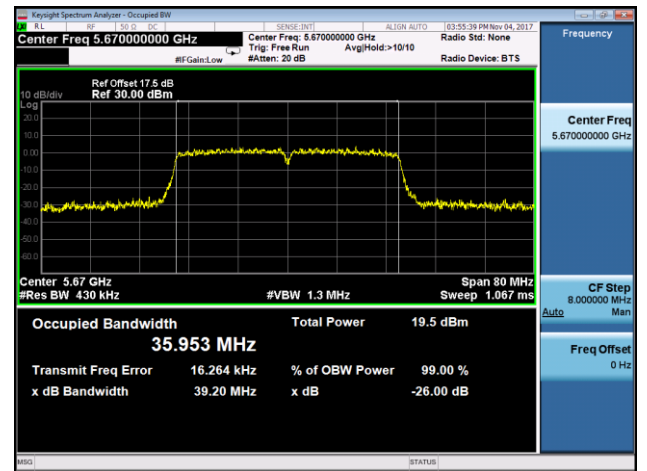
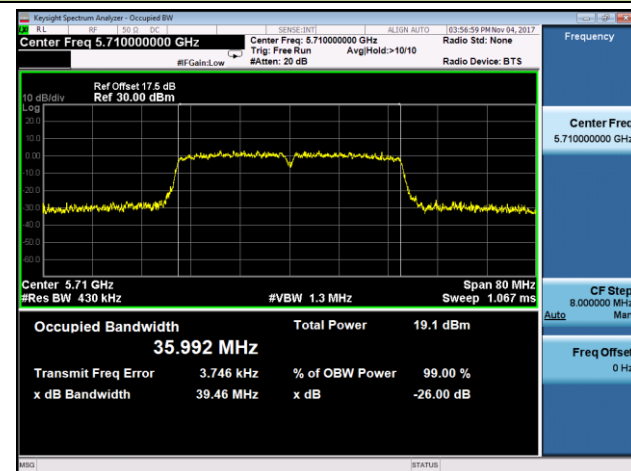
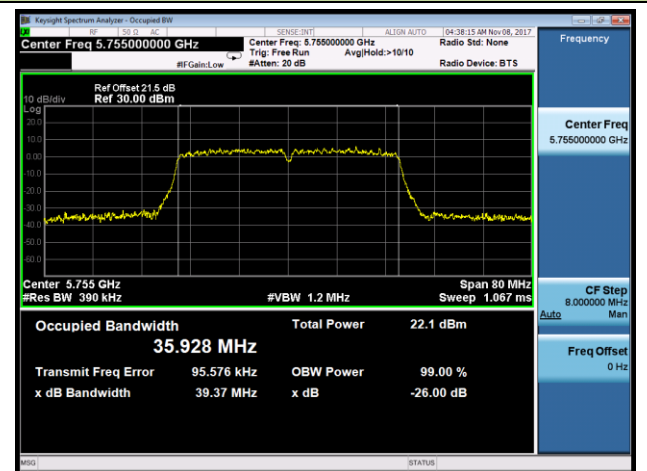
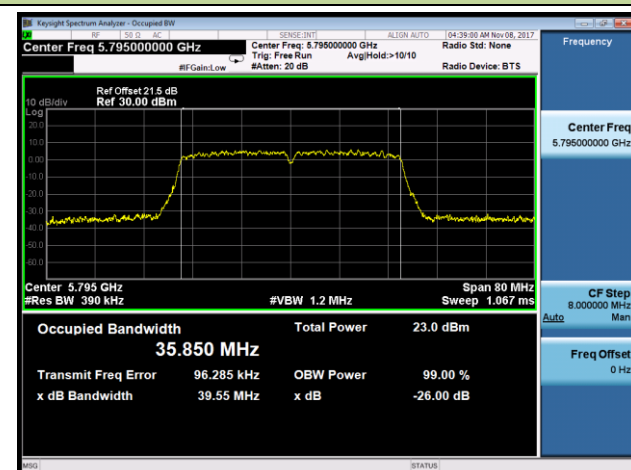
Channel 46 (5230MHz)

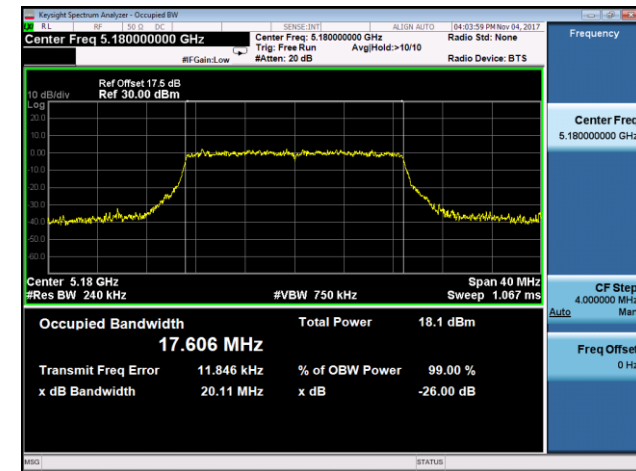
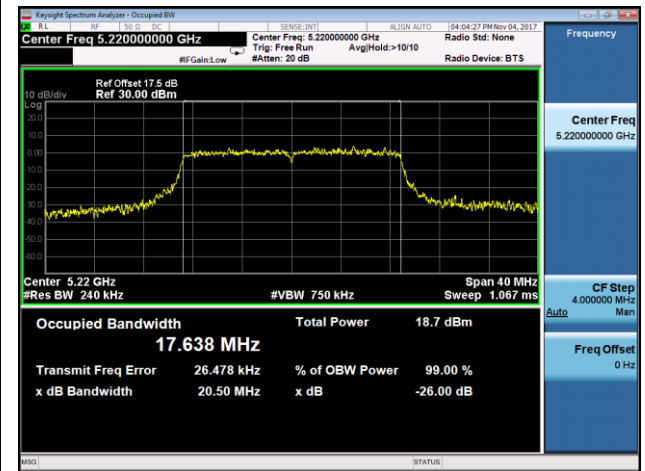
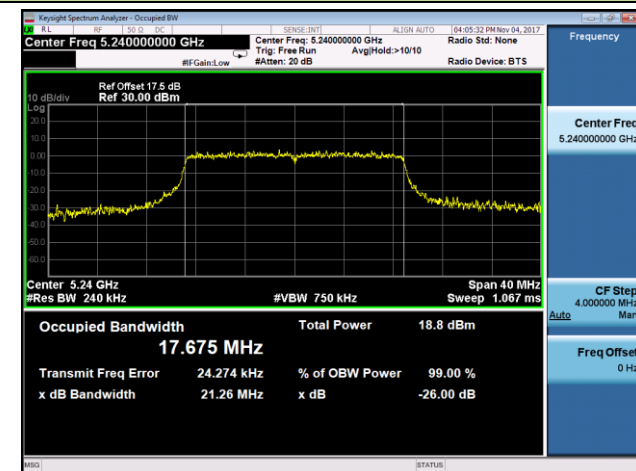
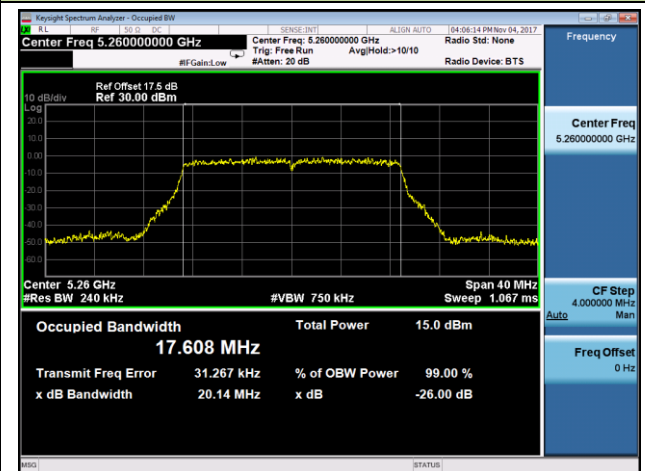
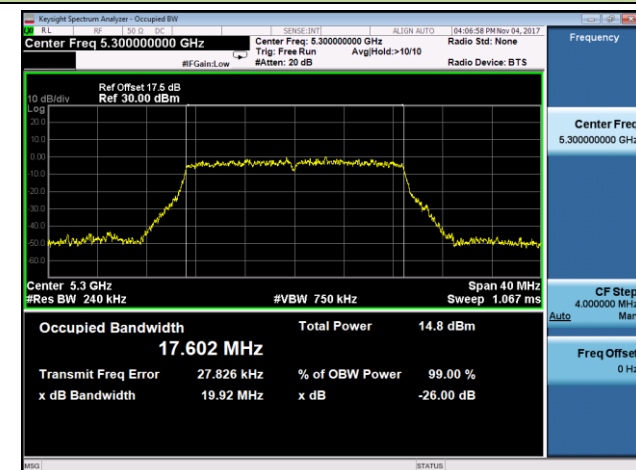
Channel 54 (5270MHz)

Channel 62 (5310MHz)

Channel 102 (5510MHz)

Channel 110 (5550MHz)

802.11n-HT40 26dB Bandwidth & 99% Bandwidth - Ant 1 / Ant 0 + 1 + 2 + 3**Channel 118 (5590MHz)****Channel 134 (5670MHz)****Channel 142 (5710MHz)****Channel 151 (5755MHz)****Channel 159 (5795MHz)**

802.11ac-VHT20 26dB Bandwidth & 99% Bandwidth - Ant 1 / Ant 0 + 1 + 2 + 3
Channel 36 (5180MHz)

Channel 44 (5220MHz)

Channel 48 (5240MHz)

Channel 52 (5260MHz)

Channel 60 (5300MHz)

Channel 64 (5320MHz)
