

1. Set the Receiver and Transmitter dip switches to the same positions. Transmitter and Receiver must be separated by a minimum of 3 feet during test.
2. Apply power (+12-14Vdc) to the Receiver (Image 1).
3. Verify PWR LED is on (Image 1).
4. Apply power (+12-14Vdc) to the Transmitter (Image 2).
5. Verify Receiver LEDs (qty 4) are on (Image 2).
6. End Test, Mark as pass or fail accordingly.

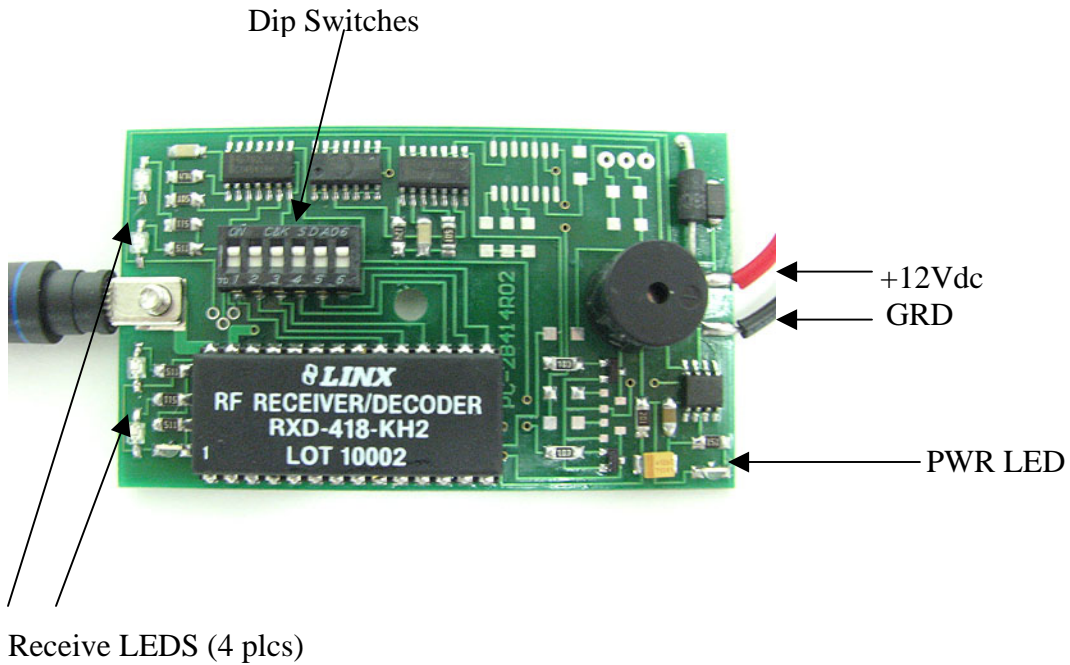

Image 1. Receiver

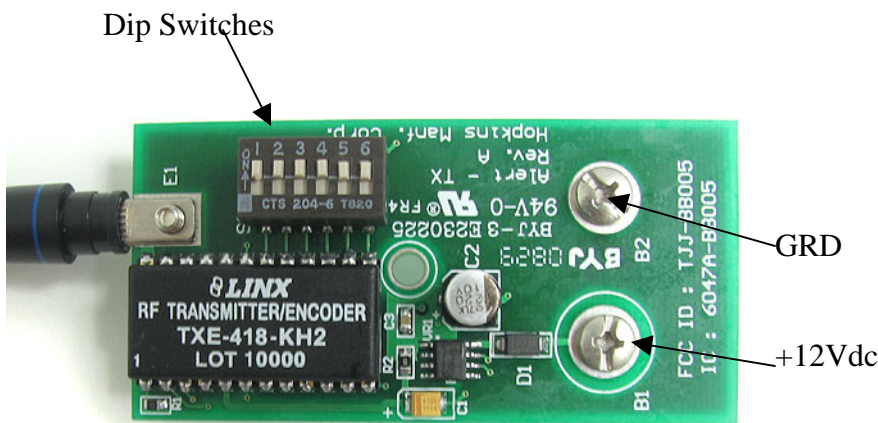

Image 2. Transmitter