FCC Test Report

Report No.: AGC12351012SZ03F2

FCC ID : TJ7BTK-718
PRODUCT DESIGNATION : Bluetooth Headset
BRAND NAME : BTK/KISS
TEST MODEL : BTK-718
CLIENT : Kiss Communications Technology Co., Ltd
DATE OF ISSUE : January 5, 2011
STANDARD(S) : FCC Part 15 Rules

Attestation of **Global Compliance Co., Ltd.**

CAUTION: This report shall not be reproduced except in full without the written permission of the test laboratory and shall not be quoted out of context.

VERIFICATION OF COMPLIANCE

Applicant	Kiss Communications Technology Co., Ltd
	Room 13A20,14F,New Asia International Digital Center,No.55 Xi Di Er Road,Li wan District
Manufacturer	Kiss Communications Technology Co., Ltd
	Room 13A20,14F,New Asia International Digital Center,No.55 Xi Di Er Road,Li wan District
Product Designation	Bluetooth Headset
Brand Name	BTK,KISS
Model Name	BTK-718,BTK-719
Model Difference	The two models are 100% identical except for appearance.
FCC ID	TJ7BTK-718
Report Number	AGC12351012SZ03F2
Date of Test	Dec.28, 2010 to Jan.3, 2011

WE HEREBY CERTIFY THAT:

The above equipment was tested by Attestation of Global Compliance Co., Ltd. The test data, data evaluation, test procedures, and equipment configurations shown in this report were made in accordance with the procedures given in ANSI C63.4 (2003) and the energy emitted by the sample EUT tested as described in this report is in compliance with radiated emission limits of FCC Rules Part 15.247.

Checked By: 
Forrest Lei Jan.5, 2011

Authorized By 
King Zhang Jan.5, 2011

TABLE OF CONTENTS

1. GENERAL INFORMATION	4
1.1 PRODUCT DESCRIPTION	4
1.2 TABLE OF CARRIER FREQUENCIES	4
1.3 RECEIVER INPUT BANDWIDTH	4
1.4 EXAMPLE OF A HOPPING SEQUENCY IN DATA MODE	5
1.5 EQUALLY AVERAGE USE OF FREQUENCIES AND BEHAVIOUR	5
1.6 RELATED SUBMITTAL(S) / GRANT (S)	5
1.7 TEST METHODOLOGY	5
1.8 TEST FACILITY	6
1.9 SPECIAL ACCESSORIES	6
1.10 EQUIPMENT MODIFICATIONS	6
2.SYSTEM TEST CONFIGURATION	7
2.1 CONFIGURATION OF TESTED SYSTEM	7
2.2 EQUIPMENT USED IN TESTED SYSTEM	7
3.SUMMARY OF TEST RESULTS	8
4.DESCRPTION OF TEST MODES	8
5MAXIMUM OUTPUT POWER	9
5.1 MEASUREMENT PROCEDURE	9
5.2 TEST SET-UP (BLOCK DIAGRAM OF CONFIGURATION)	9
5.3 MEASUREMENT EQUIPMENT USED	12
5.4 LIMITS AND MEASUREMENT RESULT	13
6 20 DB BANDWIDTH	14
6.1 MEASUREMENT PROCEDURE	14
6.2 TEST SET-UP (BLOCK DIAGRAM OF CONFIGURATION)	14
6.3 MEASUREMENT EQUIPMENT USED	14
6.4 LIMITS AND MEASUREMENT RESULTS	14
7. MAXIMUM CONDUCTED OUTPUT POWER SPECTRAL DENSITY (N/A)	20
7.1 MEASUREMENT PROCEDURE	20
7.2 TEST SET-UP (BLOCK DIAGRAM OF CONFIGURATION)	20
7.3 MEASUREMENT EQUIPMENT USED	20
7.4 LIMITS AND MEASUREMENT RESULT	20
8. OUT OF BAND EMISSION	21
8.1 MEASUREMENT PROCEDURE	21
8.2 TEST SET-UP (BLOCK DIAGRAM OF CONFIGURATION)	21
8.3 MEASUREMENT EQUIPMENT USED	21
8.4 LIMITS AND MEASUREMENT RESULT	21
9 BAND EDGE EMISSION	32
9.1 MEASUREMENT PROCEDURE	32
9.2 TEST SET-UP	32
9.3 TEST RESULT	32
10 NUMBER OF HOPPING FREQUENCY	37
10.1 MEASUREMENT PROCEDURE	37
10.2 TEST SETUP (BLOCK DIAGRAM OF CONFIGURATION)	37
10.3 MEASUREMENT EQUIPMENT USED	37
10.4 LIMITS AND MEASUREMENT RESULT	37

11 TIME OF OCCUPANCY (DWELL TIME)	39
11.1 MEASUREMENT PROCEDURE	39
11.2 TEST SETUP (BLOCK DIAGRAM OF CONFIGURATION).....	39
11.3 MEASUREMENT EQUIPMENT USED	39
11.4 LIMITS AND MEASUREMENT RESULT	39
12. FREQUENCY SEPARATION	46
12.1 MEASUREMENT PROCEDURE	46
12.2 TEST SETUP (BLOCK DIAGRAM OF CONFIGURATION).....	46
12.3 MEASUREMENT EQUIPMENT USED	46
12.4 LIMITS AND MEASUREMENT RESULT	46
APPENDIX I	52
PHOTOGRAPHS OF THE EUT	52
PPENDIX II	56
PHOTOGRAPHS OF THE TEST SETUP	56

1. GENERAL INFORMATION

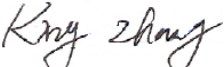
1.1 PRODUCT DESCRIPTION

The EUT is a **Bluetooth Headset** designed as an “Communication Device”. It is designed by way of utilizing the FHSS technology to achieve the system operation.

A major technical description of EUT is described as following

Operation Frequency	2.402 GHz to 2.480GHz
Rated Output Power	Bluetooth (1Mbps) 1.1dBm Bluetooth EDR (2Mbps)1.5dBm Bluetooth EDR(3Mbps)1.83dBm
Modulation	GFSK, $\pi/4$ -DQPSK, 8-DPSK
Number of channels	79
Antenna Designation	Integrated Antenna
Antenna Gain	1.02dBi
Power Supply	DC3.7V by battery

1.2 TABLE OF CARRIER FREQUENCIES

Frequency Band	Channel Number	Frequency
2400~2483.5MHZ	0	2402MHZ
	1	2403MHZ
	:	:
	38	2440 MHZ
	39	2441 MHZ
	40	2442 MHZ
	:	:
	77	2479 MHZ
	78	2480 MHZ

1.3 RECEIVER INPUT BANDWIDTH

The input bandwidth of the receiver is 1MHZ, In every connection one Bluetooth device is the master and the other one is slave. The master determines the hopping sequence. The slave follows this sequence. Both devices shift between RX and TX time slot according to the clock of the master. Additionally the type of connection (e.g. single of multislot packet) is set up at the beginning of the connection. The master adapts its hopping frequency and its TX/RX timing according to the packet type of the connection. Also the slave of the connection will use these settings.

Repeating of a packet has no influence on the hopping sequence. The hopping sequence generated by the master of the connection will be followed in any case. That means, a repeated packet will not be send on the same frequency, it is send on the next frequency of the hopping sequence.

1.4 EXAMPLE OF A HOPPING SEQUENCY IN DATA MODE

Example of a 79 hopping sequence in data mode:

40,21,44,23,42,53,46,55,48,33,52,35,50,65,54,67
56,37,60,39,58,69,62,71,64,25,68,27,66,57,70,59
72,29,76,31,74,61,78,63,01,41,05,43,03,73,07,75
09,45,13,47,11,77,15,00,64,49,66,53,68,02,70,06
01,51,03,55,05,04

1.5 EQUALLY AVERAGE USE OF FREQUENCIES AND BEHAVIOUR

The generation of the hopping sequence in connection mode depends essentially on two input values:

- 1 LAP/UAP of the master of the connection
- 2 Internal master clock

The LAP(lower address part) are the 24 LSB's of the 48 BD_ADDRESS.The BD_ADDRESS is an unambiguous number of every Bluetooth unit.The UAP(upper address part) are the 24MSB's of the 48BD_ADDRESS

The internal clock of a Bluetooth unit is derived from a free running clock which is never adjusted and is never turned off.For synchronisation with other units only offset are used.It has no relation to the time of the day.Its resolution is at least half the RX/TX slot length of 312.5us.The clock has a cycle of about One day(23h30).In most case it is implemented as 28 bit counter.For the deriving of the hopping sequence the entire.

LAP(24 bits),4LSB's(4bits)(Input 1) and the 27MSB's of the clock(Input 2) are used.With this input values different mathematical procedures(permutations,additions,XOR-operations)are performed to generate the Sequence.This will be done at the beginning of every new transmission.

Regarding short transmissions the Bluetooth system has the following behaviour:

The first connection between the two devices is established,a hopping sequence was generated.For Transmitting the wanted data the complete hopping sequence was not used.The connection ended.

The second connection will be established.A new hopping sequence is generated.Due to the fact the Bluetooth clock has a different value,because the period between the two transmission is longer(and it cannot be shorter)than the minimum resolution of the clock(312.5us).The hopping sequence will always differ from the first one.

1.6 RELATED SUBMITTAL(S) / GRANT (S)

This submittal(s) (test report) is intended for **FCC ID: TJ7BTK-718** filing to comply with Section 15.247 of the FCC Part 15, Subpart C Rules.

1.7 TEST METHODOLOGY

Both conducted and radiated testing were performed according to the procedures in ANSI C63.4 (2003). Radiated testing was performed at an antenna to EUT distance 3 meters.

1.8 TEST FACILITY

All measurement facilities used to collect the measurement data are located at Attestation of Global Compliance Co., Ltd.
1F., No.2 Building, Huafeng No.1 Technical Industrial Park, Sanwei, Xixiang, Baoan District, Shenzhen
The test site is constructed and calibrated to meet the FCC requirements in documents ANSI C63.4: 2003.
FCC register No.: 259865

1.9 SPECIAL ACCESSORIES

Not available for this EUT intended for grant.

1.10 EQUIPMENT MODIFICATIONS

Not available for this EUT intended for grant.

2. SYSTEM TEST CONFIGURATION

2.1 CONFIGURATION OF TESTED SYSTEM

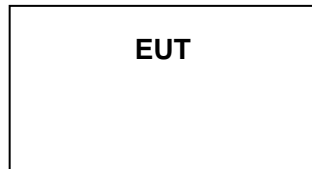

2.2 EQUIPMENT USED IN TESTED SYSTEM

Item	Equipment	Mfr/Brand	Model/Type No.	FCC ID
1	Bluetooth Headset	BTK,KISS	BTK-718	TJ7BTK-718

3. SUMMARY OF TEST RESULTS

FCC RULES	DESCRIPTION OF TEST	RESULT
§15.207	Conduction Emission	Not applicable
§15.209	Radiated Emission	Compliant
§15.247	Maximum Output Power	Compliant
§15.247	20 dB Bandwidth	Compliant
§15.247	Band Edges	Compliant
§15.247	Spurious Emission	Compliant
§15.247	Frequency Separation	Compliant
§15.247	Number of Hopping Frequency	Compliant
§15.247	Time of Occupancy	Compliant

4. DESCRIPTION OF TEST MODES

1. The EUT has been set to operate continuously on the lowest,middle and highest operation frequency individually.
2. The EUT stays in continuous transmitting mode on the operation frequency being set.

5 MAXIMUM OUTPUT POWER

5.1 MEASUREMENT PROCEDURE

CONDUCTED METHOD

1. The EUT was placed on a turn table which is 0.8m above ground plane.
2. Connect EUT RF output port to the Spectrum Analyzer through an RF attenuator
3. Set the EUT Work on the top, the middle and the bottom operation frequency individually.
4. Set SPA Centre Frequency = Operation Frequency, RBW= 3 MHz, VBW= 3 MHz.
5. Set SPA Trace 1 Max hold, then View.

RADIATED METHOD

According to ANSI C63.4:2003

5.2 TEST SET-UP (BLOCK DIAGRAM OF CONFIGURATION)

CONDUCTED METHOD

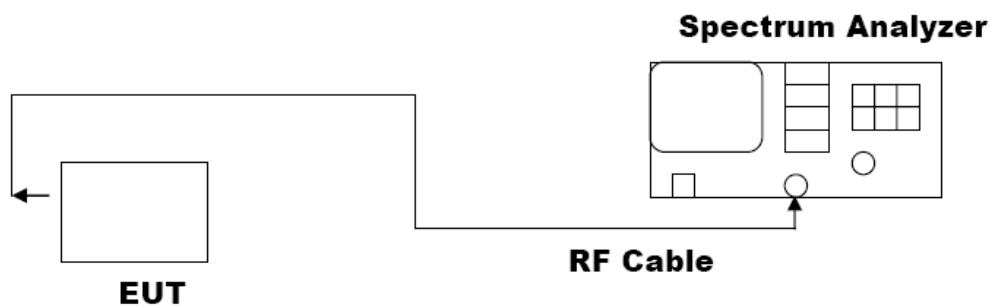

RADIATED EMISSION TEST SETUP

RADIATED EMISSION TEST SETUP BELOW 30MHz

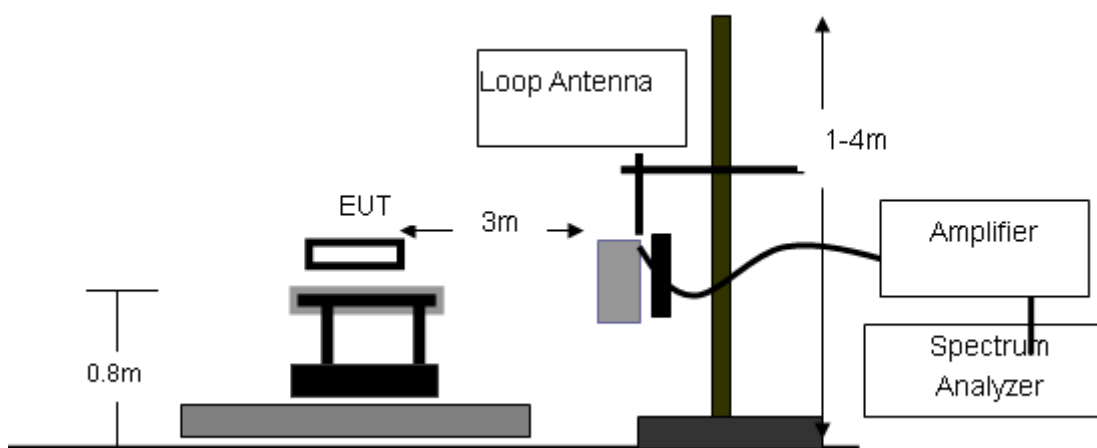

RADIATED MISSION TEST SETUP 30MHz-1000MHz

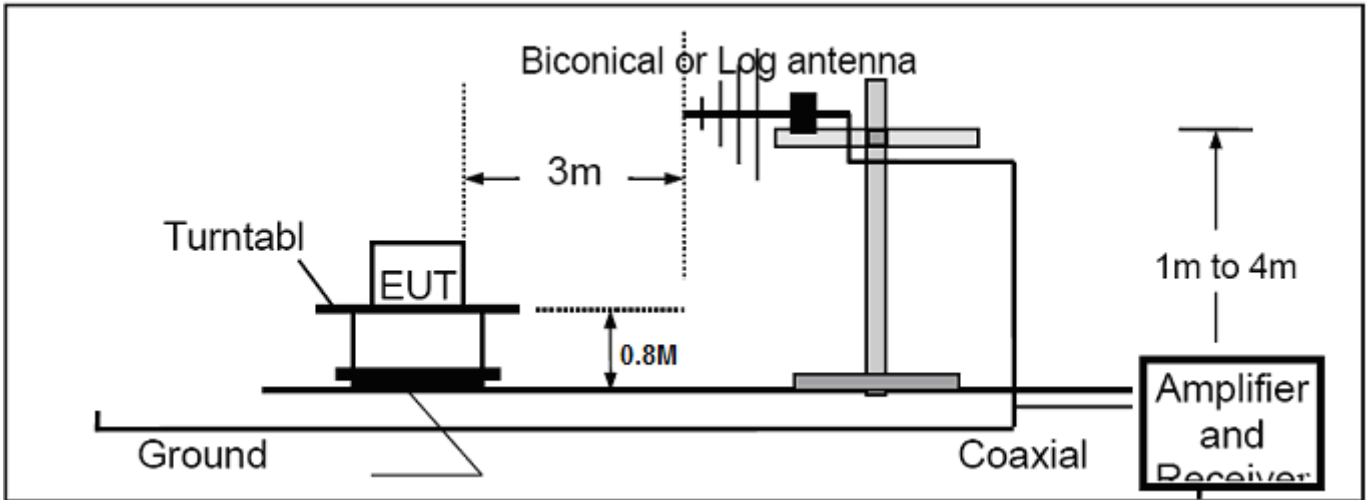

RADIATED MISSION TEST SETUP ABOVE 1000MHz

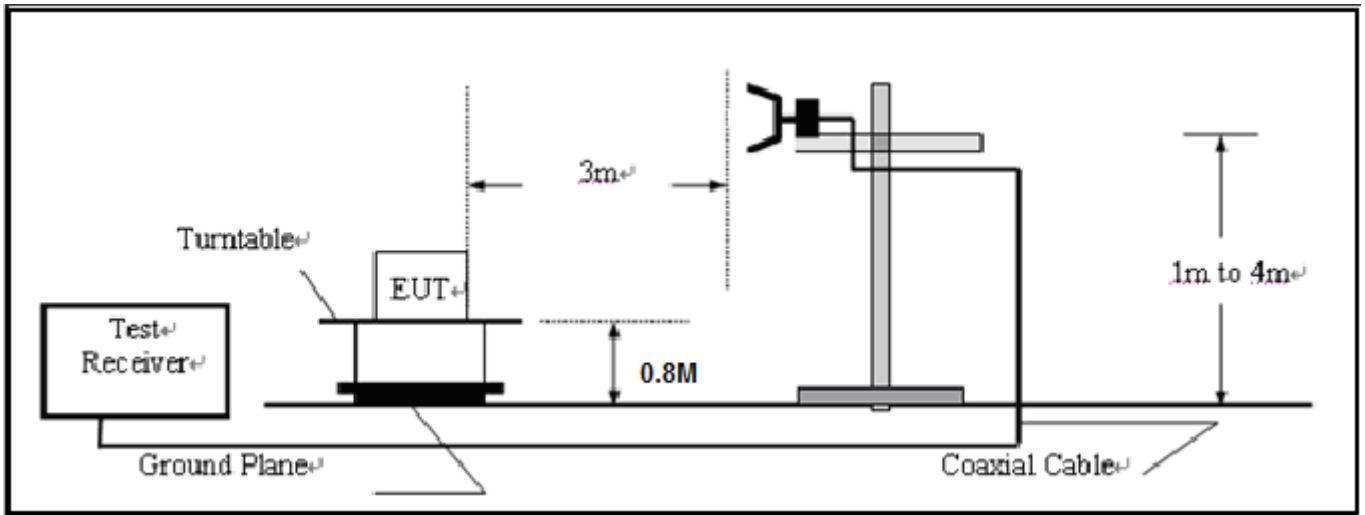

EIRP TEST SETUP

TEST SETUP BELOW 1GHZ

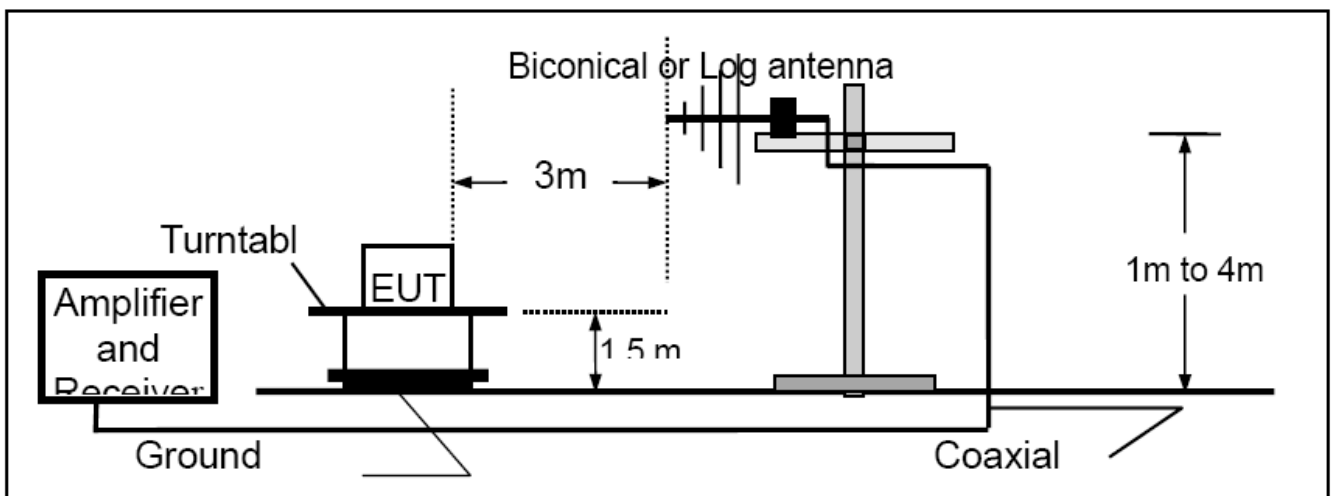

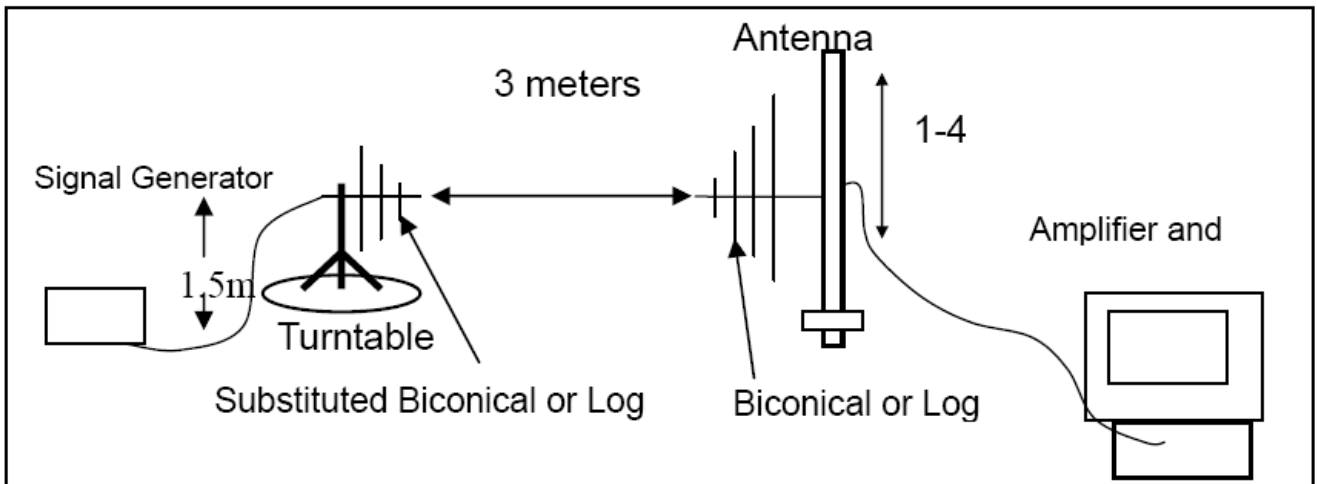

TEST SETUP ABOVE 1GHZ

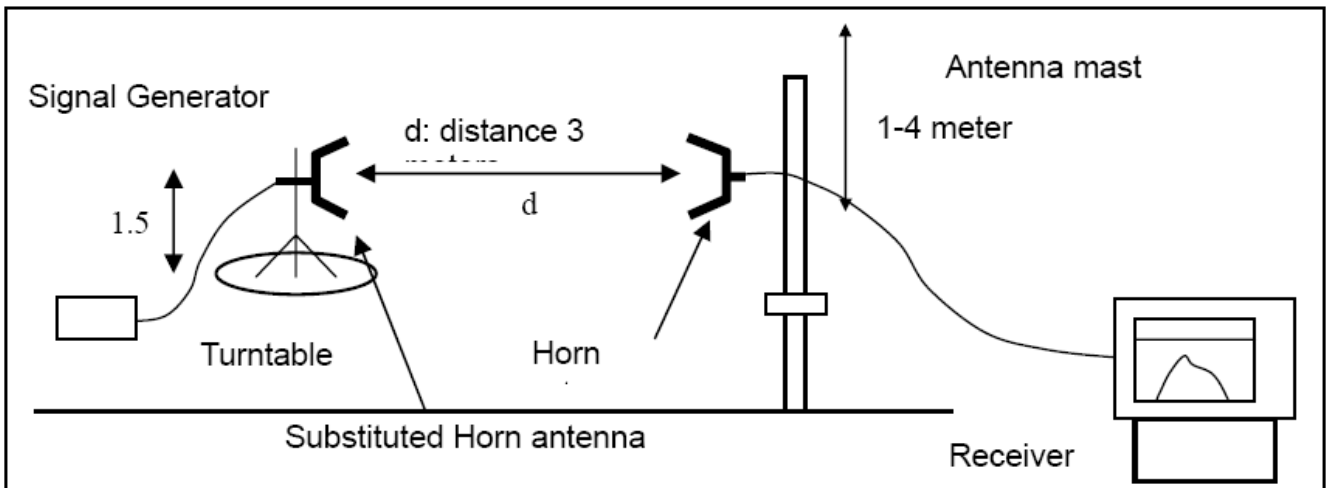
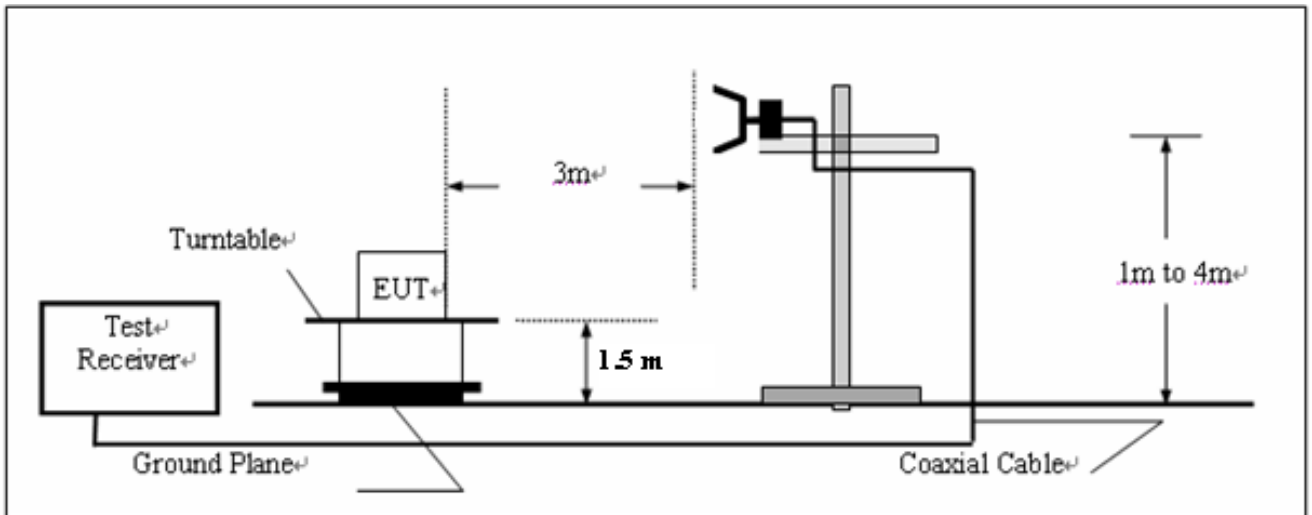

5.3 MEASUREMENT EQUIPMENT USED

Description	Manufacturer	Model	SERIAL NUMBER	Cal. Date	Cal. Due
Spectrum Analyzer	Agilent	E4440A	N/A	06/29/2010	06/28/2011
Amplifier	EM	EM30180	0607030	06/29/2010	06/28/2011
Horn Antenna	EM	EM-AH-1018 0	N/A	06/29/2010	06/28/2011
EMI Test Receiver	Rohde & Schwarz	ESCI	N/A	06/29/2010	06/28/2011
Amplifier	EM	EM30180	N/A	06/29/2010	06/28/2011
Biological Antenna	A.H. Systems Inc.	SAS-521-4	N/A	06/29/2010	06/28/2011
Loop Antenna	Daze	ZN30900N	SEL0097	06/29/2010	06/28/2011
Isolation Transformer	LETEAC	LTBK	--	06/08/2010	06/07/2011

5.4 LIMITS AND MEASUREMENT RESULT

BLUETOOTH 1MBPS LIMITS AND MEASUREMENT RESULT				
Applicable Limits	Frequency	Measurement Result		
		EIRP (dBm)	Conducted (dBm)	Criteria
30 dBm	2.402GHz	-1.2	-2.39	PASS
30 dBm	2.441GHz	1.1	-0.41	PASS
30 dBm	2.480GHz	-2.3	-4.47	PASS

BLUETOOTH 2MBPS LIMITS AND MEASUREMENT RESULT				
Applicable Limits	Frequency	Measurement Result		
		EIRP (dBm)	Conducted (dBm)	Criteria
30 dBm	2.402GHz	-0.8	-2.12	PASS
30 dBm	2.441GHz	1.5	-0.25	PASS
30 dBm	2.480GHz	-1.23	-3.22	PASS

BLUETOOTH 3MBPS LIMITS AND MEASUREMENT RESULT				
Applicable Limits	Frequency	Measurement Result		
		EIRP (dBm)	Conducted (dBm)	Criteria
30 dBm	2.402GHz	-0.65	-1.89	PASS
30 dBm	2.441GHz	1.83	-0.12	PASS
30 dBm	2.480GHz	-0.3	-2.88	PASS

6 20 DB BANDWIDTH

6.1 MEASUREMENT PROCEDURE

1. The EUT was placed on a turn table which is 0.8m above ground plane.
2. Connect EUT RF output port to the Spectrum Analyzer through an RF attenuator
3. Set the EUT Work on the top, the middle and the bottom operation frequency individually.
3. Set SPA Centre Frequency = Operation Frequency, RBW= 100 KHz, VBW= 100 KHz.
4. Set SPA Trace 1 Max hold, then View.

6.2 TEST SET-UP (BLOCK DIAGRAM OF CONFIGURATION)

The Same as described in Section 6.2

6.3 MEASUREMENT EQUIPMENT USED

The same as described in Section 6.3

6.4 LIMITS AND MEASUREMENT RESULTS

BLUETOOTH 1MBPS LIMITS AND MEASUREMENT RESULT			
Applicable Limits	Measurement Result		
	Test Data (MHz)		Criteria
--	Low Channel	1.093	PASS
	Middle Channel	1.103	PASS
	High Channel	1.060	PASS

TEST PLOT OF BANDWIDTH FOR LOW CHANNEL

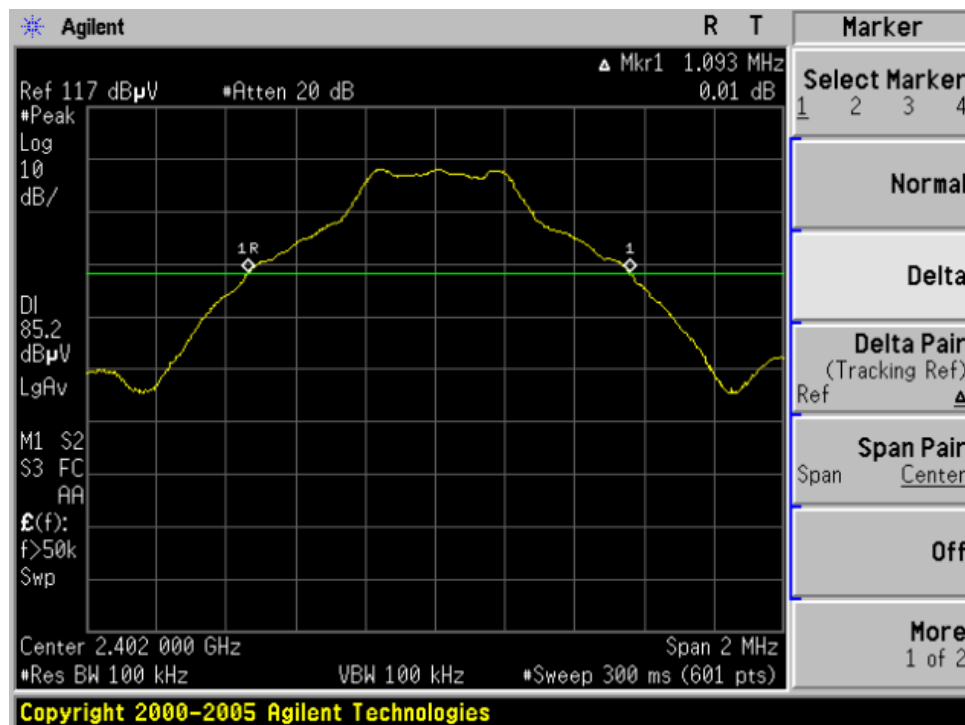

TEST PLOT OF BANDWIDTH FOR MIDDLE CHANNEL

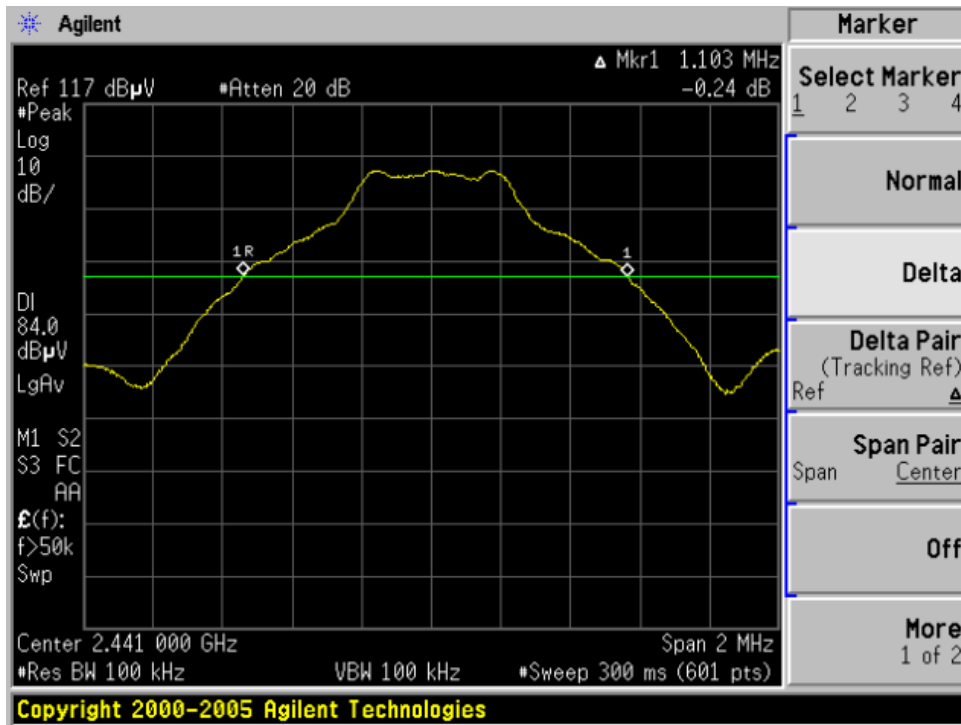

TEST PLOT OF BANDWIDTH FOR HIGH CHANNEL

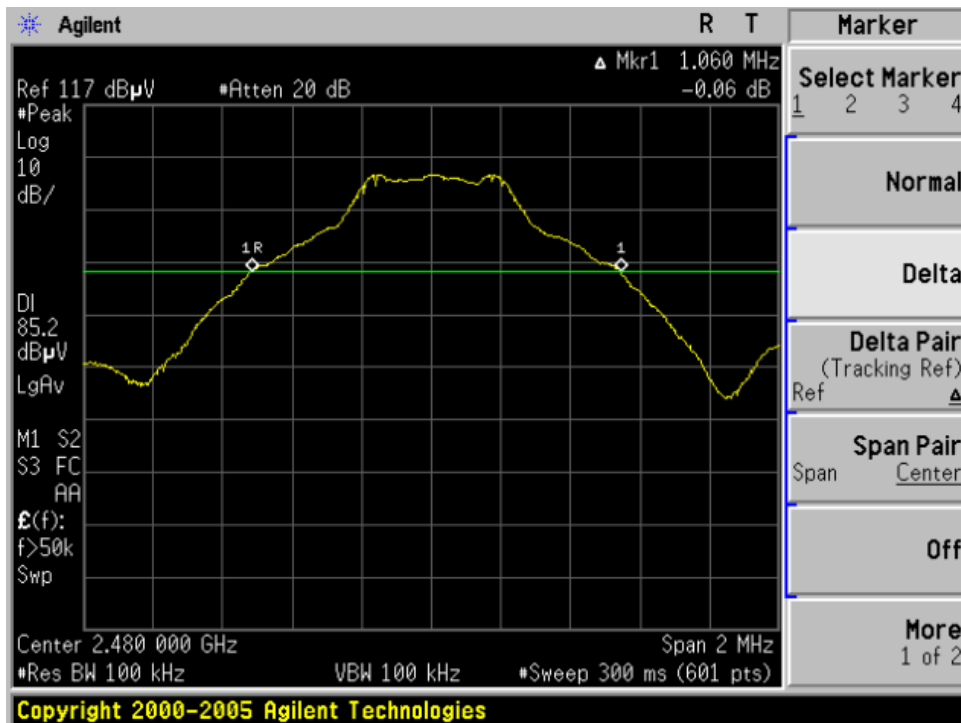

BLUETOOTH 2MBPS LIMITS AND MEASUREMENT RESULT			
Applicable Limits	Measurement Result		
	Test Data (MHz)		Criteria
--	Low Channel	1.248	PASS
	Middle Channel	1.248	PASS
	High Channel	1.248	PASS

TEST PLOT OF BANDWIDTH FOR LOW CHANNEL

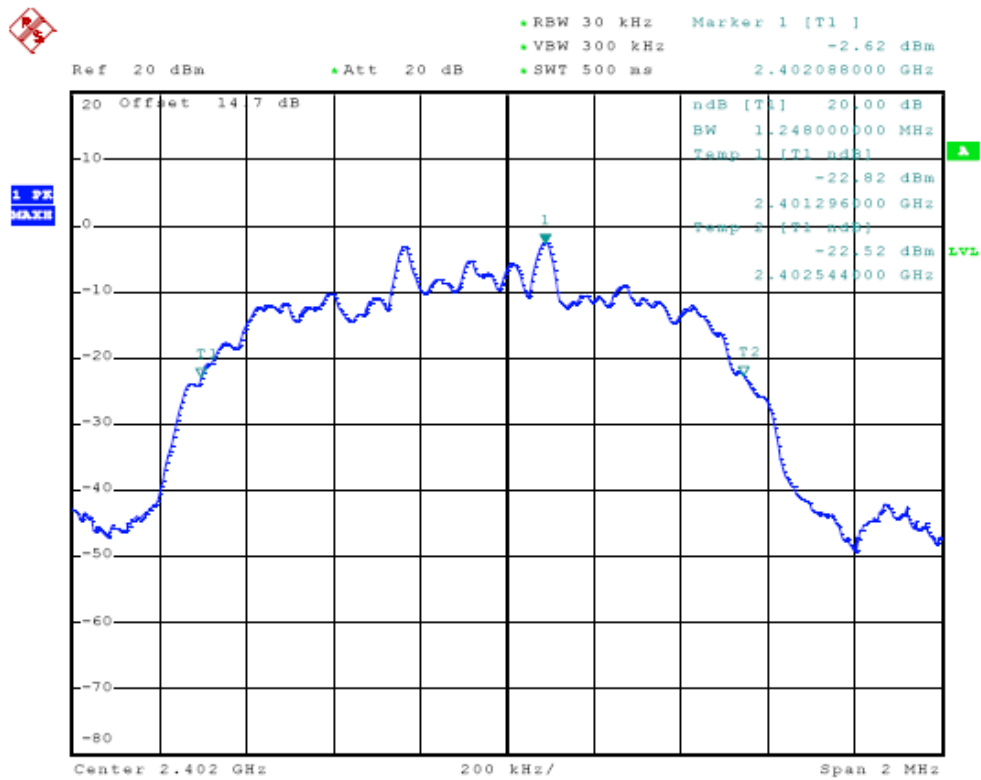

TEST PLOT OF BANDWIDTH FOR MIDDLE CHANNEL

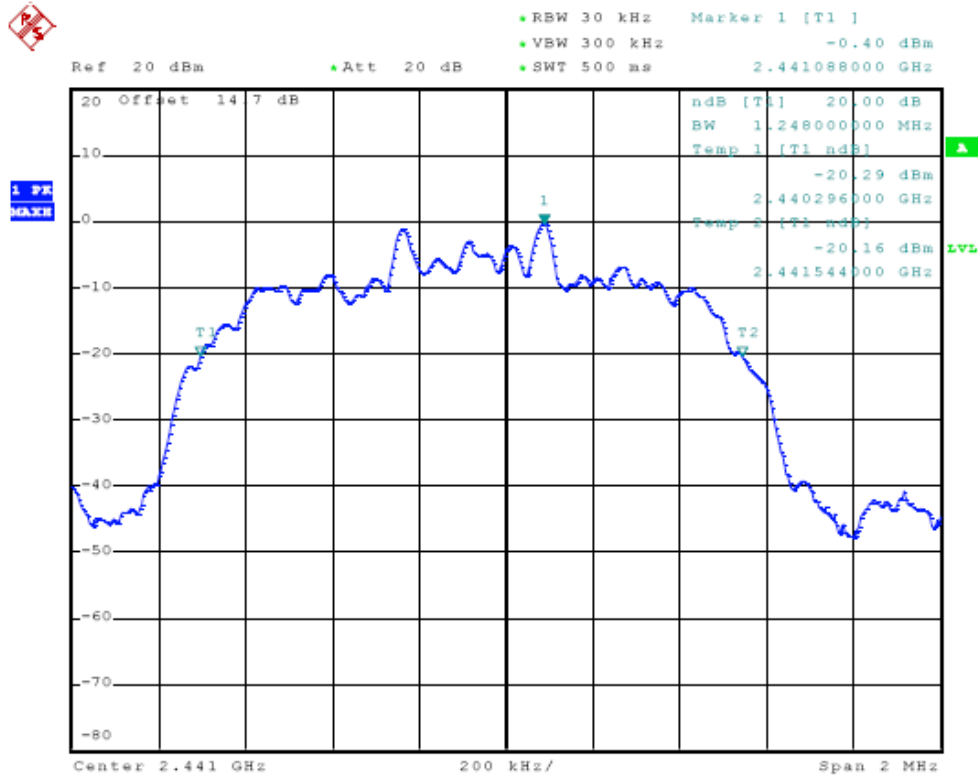

TEST PLOT OF BANDWIDTH FOR HIGH CHANNEL

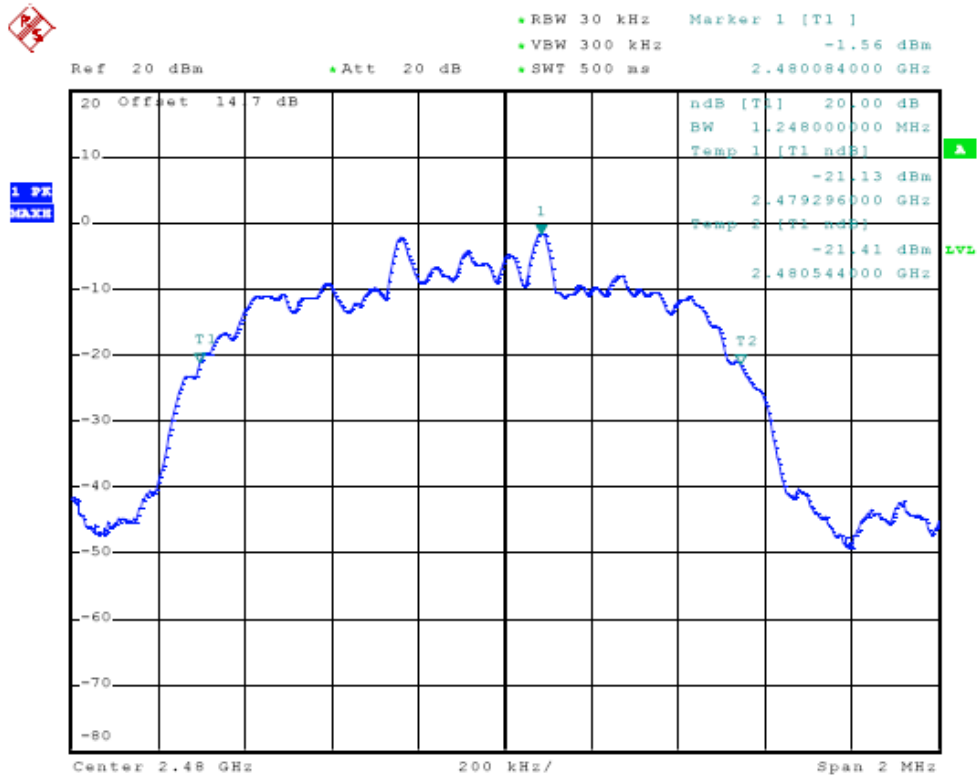

BLUETOOTH 3MBPS LIMITS AND MEASUREMENT RESULT			
Applicable Limits	Measurement Result		
	Test Data (MHz)		Criteria
--	Low Channel	1.220	PASS
	Middle Channel	1.220	PASS
	High Channel	1.220	PASS

TEST PLOT OF BANDWIDTH FOR LOW CHANNEL

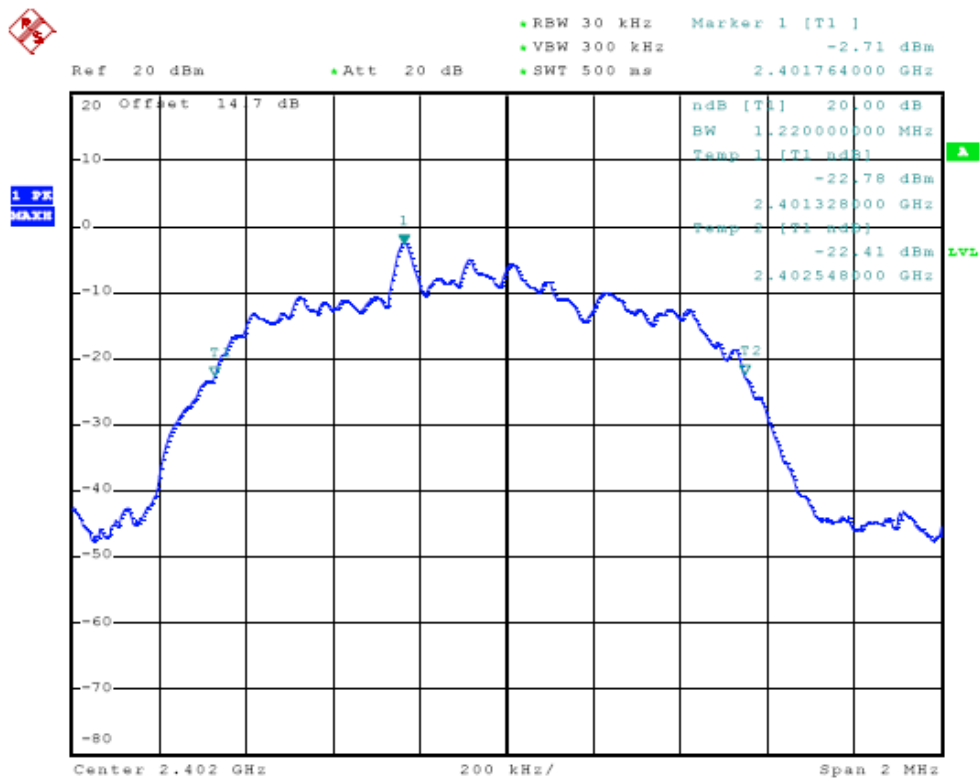

TEST PLOT OF BANDWIDTH FOR MIDDLE CHANNEL

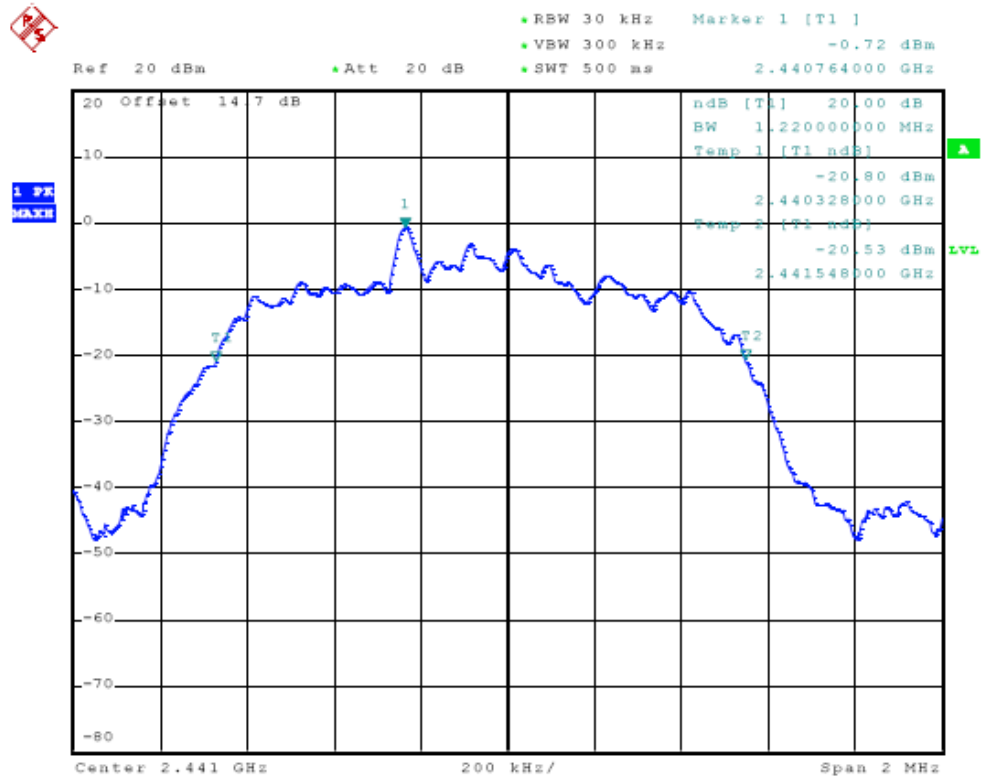

TEST PLOT OF BANDWIDTH FOR HIGH CHANNEL

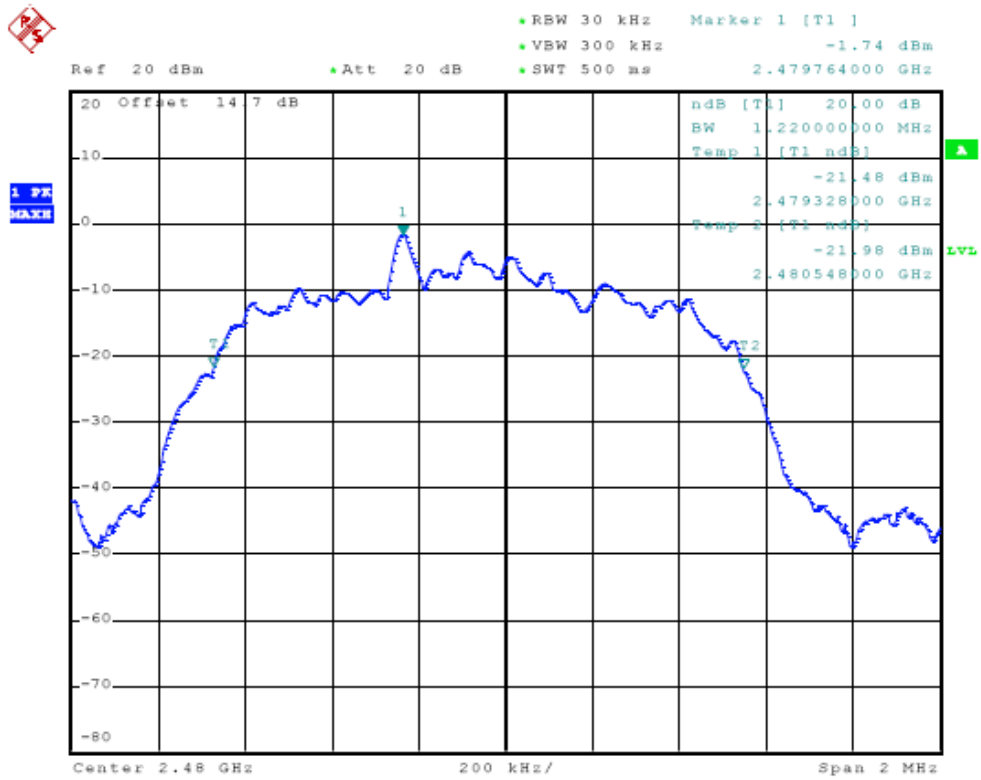

7. MAXIMUM CONDUCTED OUTPUT POWER SPECTRAL DENSITY (N/A)

7.1 MEASUREMENT PROCEDURE

- (1). The EUT was placed on a turn table which is 0.8m above ground plane.
- (2). Connect EUT RF output port to the Spectrum Analyzer through an RF attenuator
- (3). Set the EUT Work on the top, the middle and the bottom operation frequency individually.
- (4). Set SPA Centre Frequency = Operation Frequency, RBW= 3 KHz, VBW= 10 KHz., Sweep time= Auto
- (5). Set SPA Trace 1 Max hold, then View.

7.2 TEST SET-UP (BLOCK DIAGRAM OF CONFIGURATION)

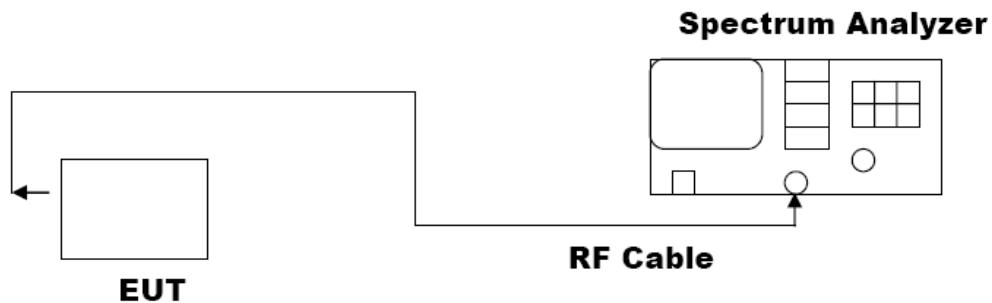

7.3 MEASUREMENT EQUIPMENT USED

SHIELDING ROOM					
EQUIPMENT TYPE	MFR	MODEL NUMBER	SERIAL NUMBER	LAST CAL.	CAL DUE.
Spectrum Analyzer	Agilent	E4440A	N/A	06/29/2010	06/28/2011

7.4 LIMITS AND MEASUREMENT RESULT

LIMITS AND MEASUREMENT RESULT			
Applicable Limits	Measurement Result		
	Test Data (dBm/3KHz)		Criteria
8 dBm / 3KHz	Low Channel	--	--
	Middle Channel	--	--
	High Channel	--	--

8. OUT OF BAND EMISSION

8.1 MEASUREMENT PROCEDURE

1. The EUT was placed on a turn table which is 0.8m above ground plane.
2. Connect EUT RF output port to the Spectrum Analyzer through an RF attenuator
3. Set the EUT Work on the top, the middle and the bottom operation frequency individually.
3. Set SPA Centre Frequency = Operation Frequency, RBW= 100 KHz, VBW= 100 KHz.
4. Set SPA Trace 1 Max hold, then View.

8.2 TEST SET-UP (BLOCK DIAGRAM OF CONFIGURATION)

The Same as described in section 6.2

1. Conducted test setup
2. Radiated Emission test Setup below 1GHz and Above 1GHz

8.3 MEASUREMENT EQUIPMENT USED

The Same as described in section 6.3

8.4 LIMITS AND MEASUREMENT RESULT

LIMITS AND MEASUREMENT RESULT		
Applicable Limits	Measurement Result	
	Test Data	Criteria
<p>In any 100 KHz Bandwidth Outside the frequency band in which the spread spectrum intentional radiator is operating, the radio frequency power that is produce by the intentional radiator shall be at least 20 dB below that in 100KHz bandwidth within the band that contains the highest level of the desired power.</p> <p>In addition, radiation emissions which fall in the restricted bands, as defined in §15.205(a), must also comply with the radiated emission limits specified in§15.209(a))</p>	At least -20dBc than the limit Specified on the BOTTOM Channel	PASS
	At least -20dBc than the limit Specified on the TOP Channel	PASS

TEST PLOT OF OUT OF BAND EMISSIONS FOR LOW CHANNEL(1Mbps)

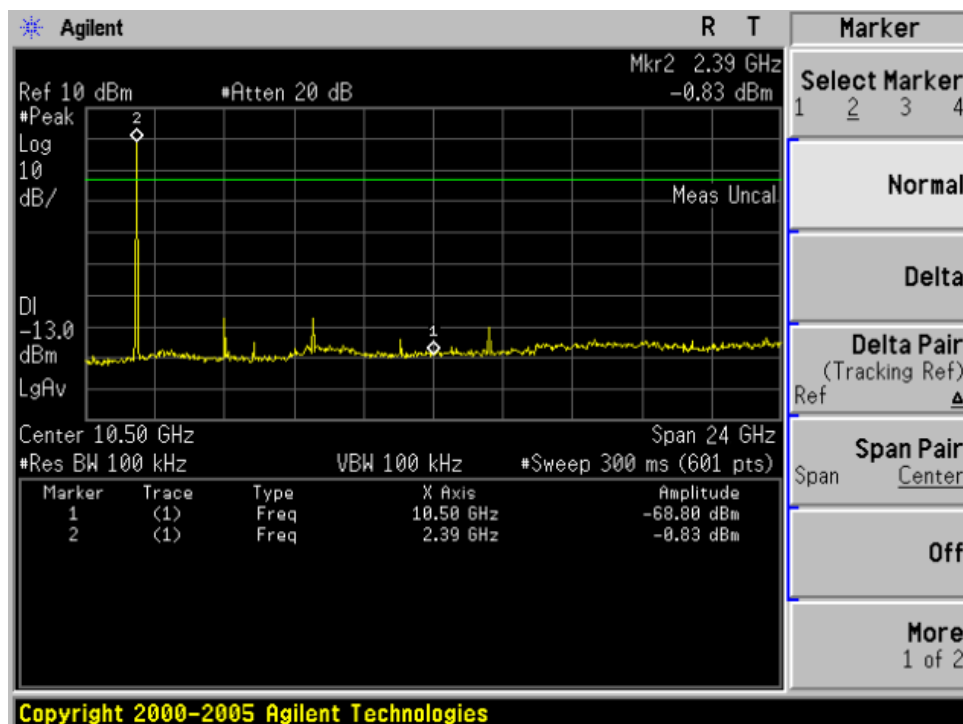
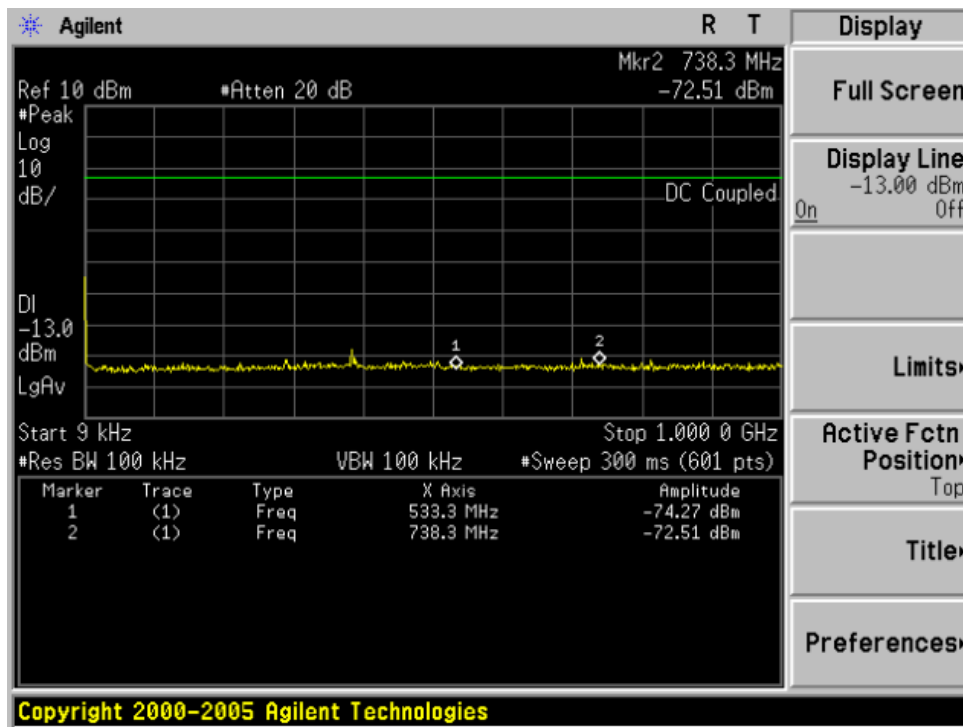

TEST PLOT OF OUT OF BAND EMISSIONS FOR MIDDLE CHANNEL (1Mbps)

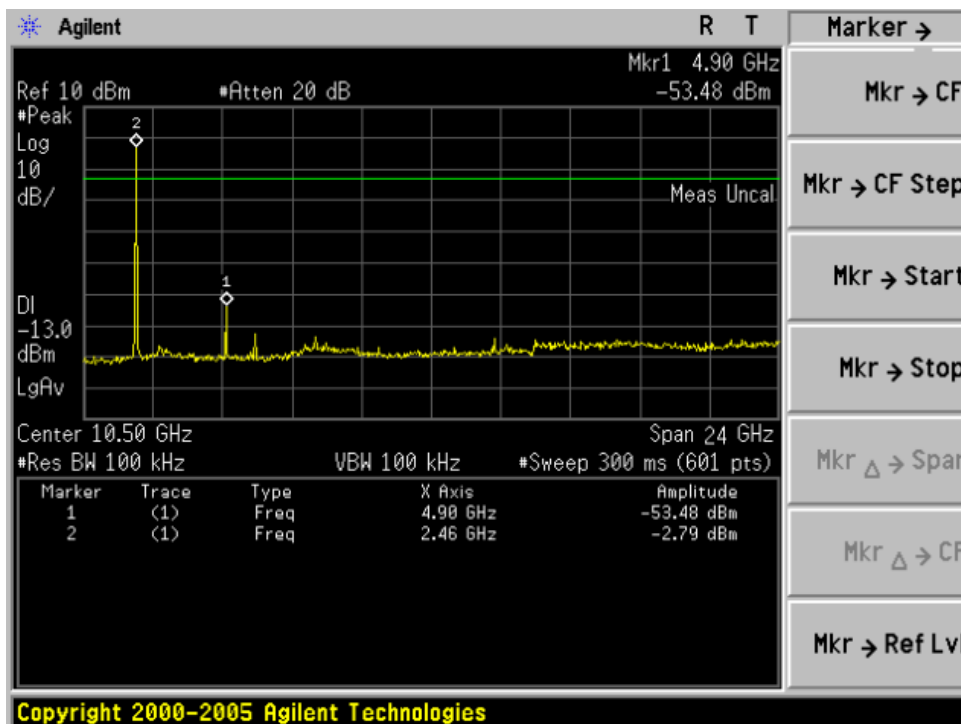
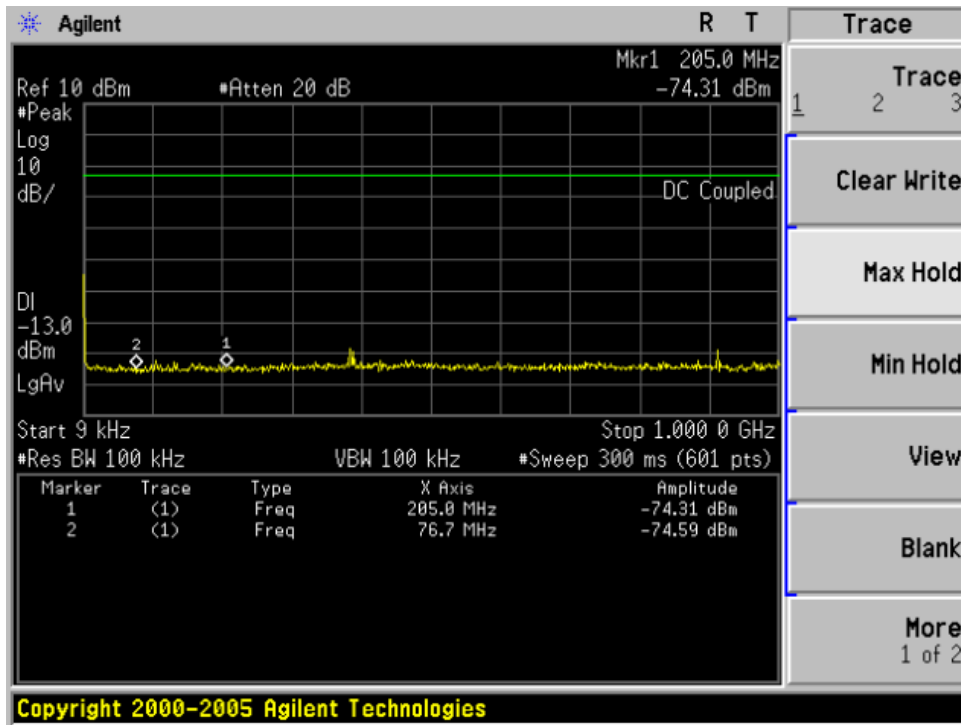

TEST PLOT OF OUT OF BAND EMISSIONS FOR HIGH CHANNEL(1Mbps)

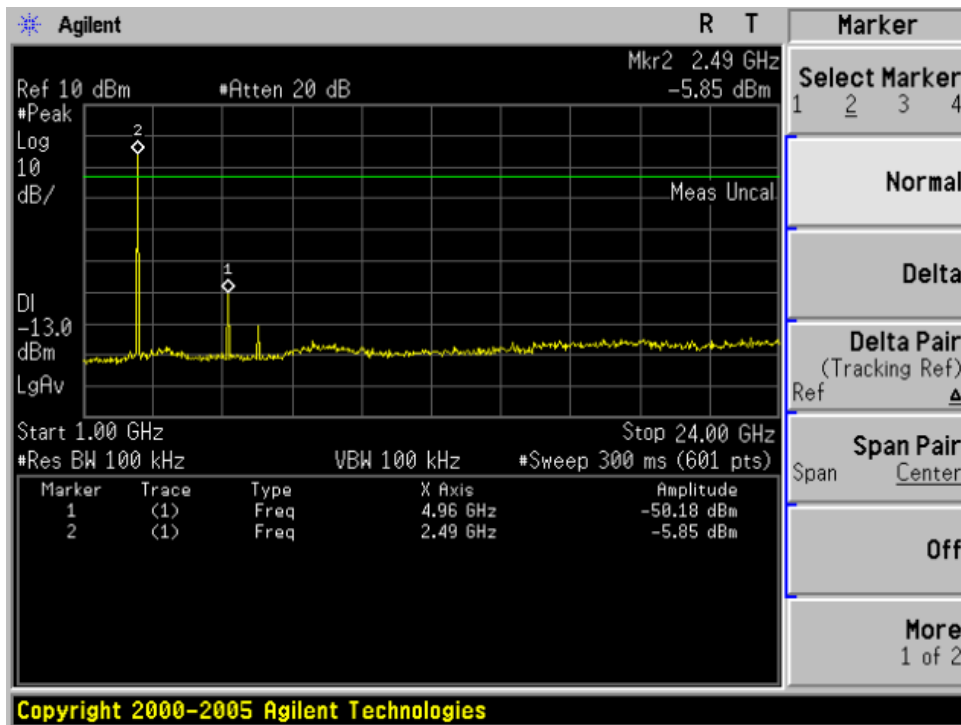
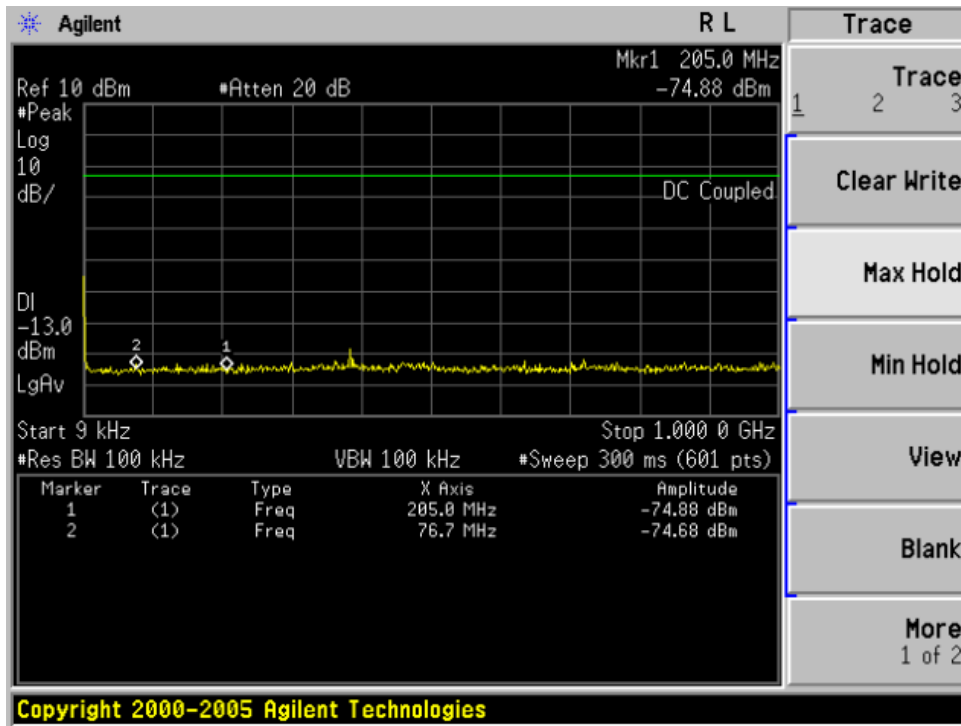

TEST PLOT OF OUT OF BAND EMISSIONS FOR HIGH CHANNEL(2Mbps)

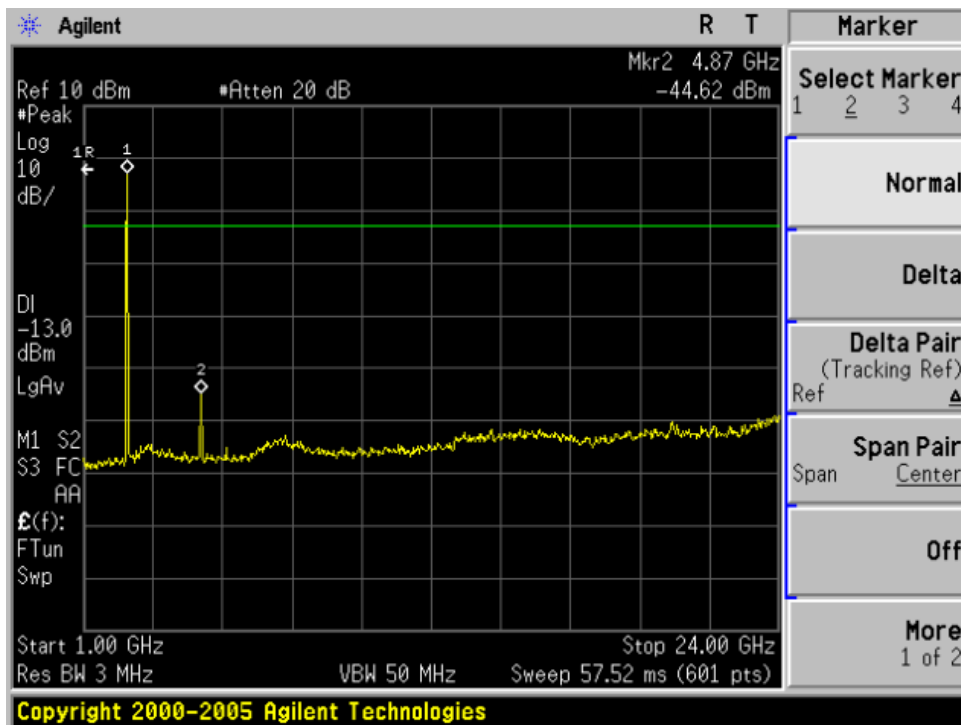
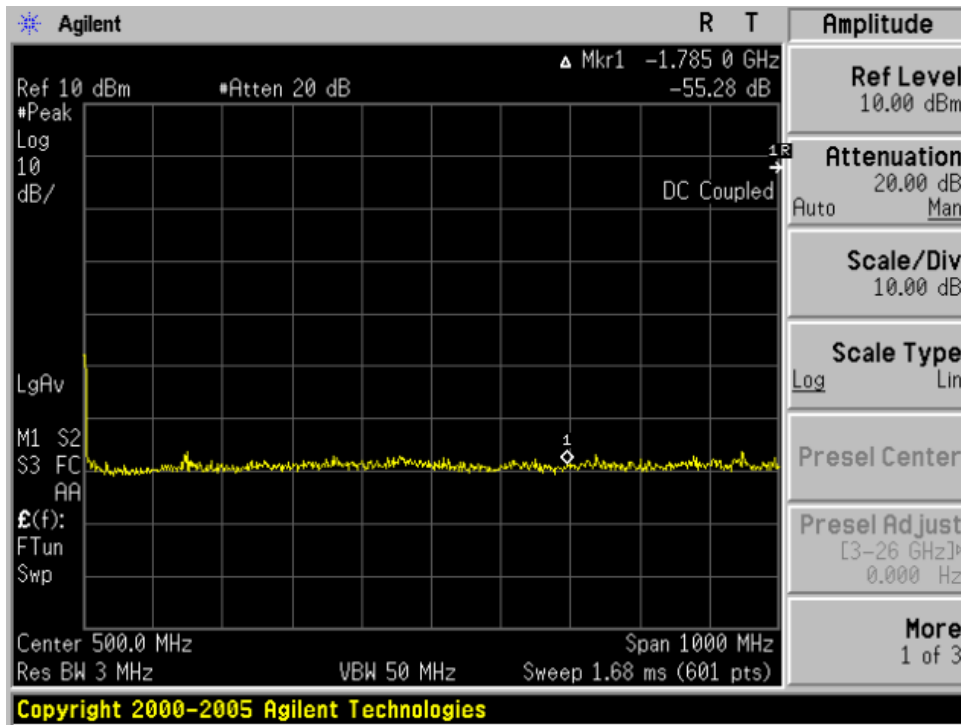

TEST PLOT OF OUT OF BAND EMISSIONS FOR HIGH CHANNEL(3Mbps)

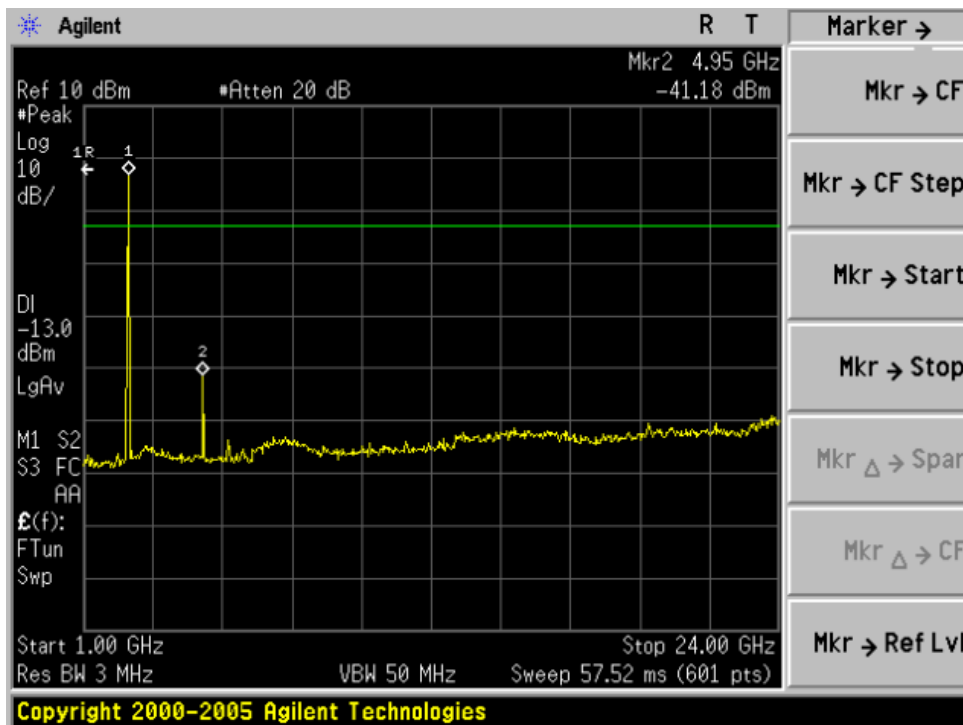
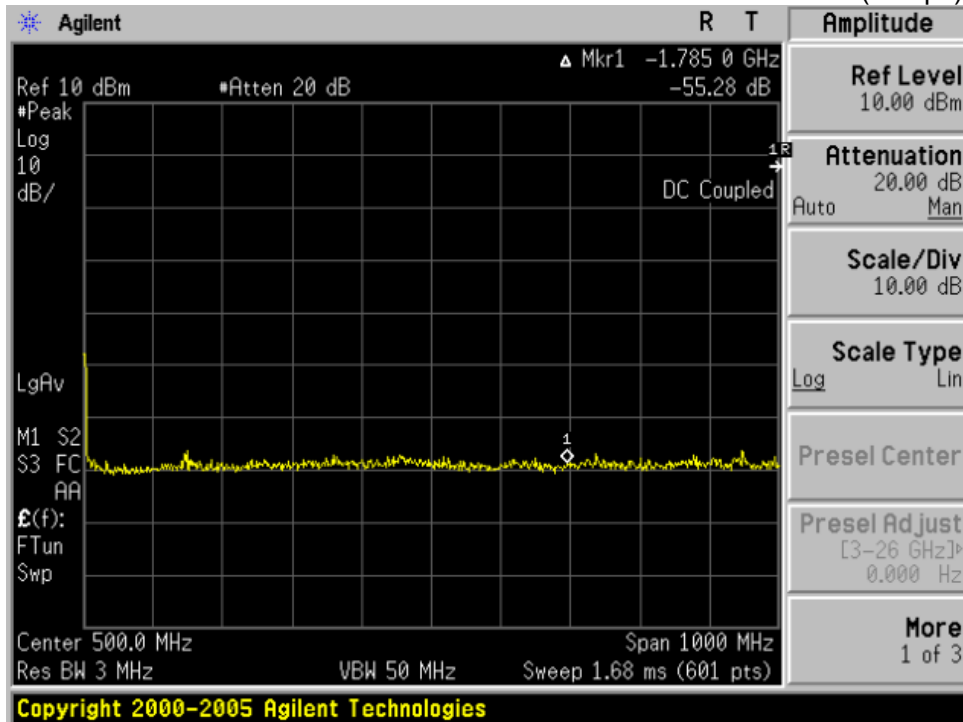

RADIATED EMISSION BELOW 30MHZ

No emission found between lowest internal used/generated frequency to 30MHz.

RADIATED EMISSION BELOW 1GHZ

EUT	Bluetooth Headset	Model Name	BTK-718
Temperature	25° C	Relative Humidity	55.4%
Pressure	960hPa	Test Voltage	DC3.7V
Test Mode	BT2402MHZ	Modulation	GFSK

Freq. (MHZ)	Ant.Pol. H/V	Detector (PK/QP)	Reading (dBuV)	Factor (dB)	Result (dBuV/m)	Limit (dBuV/m)	Margin (dB)
41.15	H	Peak	14.30	15.46	30.76	40	-10.24
135.69	H	Peak	15.59	14.11	29.7	43.5	-13.8
174.33	H	Peak	11.78	16.89	28.67	43.5	-14.83
414.78	H	Peak	13.44	19.80	33.24	46	-12.76
633.89	H	Peak	9.65	24.56	34.21	46	-11.79
911.25	H	Peak	8.12	26.38	34.5	46	-11.5
57.48	V	Peak	15.49	10.23	25.72	40	-14.28
78.43	V	Peak	17.59	9.33	26.92	40	-13.08
133.37	V	Peak	18.44	14.28	32.72	43.5	-10.78
174.18	V	Peak	13.18	18.84	32.02	43.5	-11.48
713.25	V	Peak	5.34	25.54	30.88	46	-15.12
940.23	V	Peak	4.18	26.47	30.65	46	-15.35

EUT	Bluetooth Headset	Model Name	BTK-718
	25° C	Relative Humidity	55.4%
Pressure	960hPa	Test Voltage	DC3.7V
Test Mode	BT2441MHZ	Modulation	GFSK

Freq. (MHZ)	Ant.Pol. H/V	Detector (PK/QP)	Reading (dBuV)	Factor (dB)	Result (dBuV/m)	Limit (dBuV/m)	Margin (dB)
--	H	Peak	--	--	--	--	--
--	H	Peak	--	--	--	--	--
--	V	Peak	--	--	--	--	--
--	V	Peak	--	--	--	--	--

EUT	Bluetooth Headset	Model Name	BTK-718
Temperature	25° C	Relative Humidity	55.4%
Pressure	960hPa	Test Voltage	DC3.7V
Test Mode	BT2480MHZ	Modulation	GFSK

Freq. (MHZ)	Ant.Pol. H/V	Detector (PK/QP)	Reading (dBuV)	Factor (dB)	Result (dBuV/m)	Limit (dBuV/m)	Margin (dB)
--	H	Peak	--	--	--	--	--
--	H	Peak	--	--	--	--	--
--	V	Peak	--	--	--	--	--
--	V	Peak	--	--	--	--	--

EUT	Bluetooth Headset	Model Name	BTK-718
Temperature	25° C	Relative Humidity	55.4%
Pressure	960hPa	Test Voltage	DC3.7V
Test Mode	BT2402/2441/2480MHZ	Modulation	π /4-DQPSK 8-DPSK

Freq. (MHZ)	Ant.Pol. H/V	Detector (PK/QP)	Reading (dBuV)	Factor (dB)	Result (dBuV/m)	Limit (dBuV/m)	Margin (dB)
--	H	Peak	--	--	--	--	--
--	H	Peak	--	--	--	--	--
--	V	Peak	--	--	--	--	--
--	V	Peak	--	--	--	--	--

Note: "--" means the mode at least have 20dB margin.

EUT	Bluetooth Headset	Model Name	BTK-718
Temperature	25° C	Relative Humidity	55.4%
Pressure	960hPa	Test Voltage	DC3.7V
Test Mode	BT2480MHZ	Modulation	GFSK

Freq. (MHZ)	Ant.Pol. H/V	Peak Reading (dBuV)	AV Reading (dBuV)	Factor (dB)	Result		Peak Limit (dBuV/m)	AV Limit (dBuV/m)	Margin
					Peak (dBuV/m)	AV (dBuV/m)			
--	H	--	--	--	--	--	--	--	--
--	H	--	--	--	--	--	--	--	--
--	V	--	--	--	--	--	--	--	--
--	V	--	--	--	--	--	--	--	--

EUT	Bluetooth Headset	Model Name	BTK-718
Temperature	25° C	Relative Humidity	55.4%
Pressure	960hPa	Test Voltage	DC3.7V
Test Mode	BT2402/2441/2480MHZ	Modulation	π /4-DQPSK 8-DPSK

Freq. (MHZ)	Ant.Pol. H/V	Peak Reading (dBuV)	AV Reading (dBuV)	Factor (dB)	Result		Peak Limit (dBuV/m)	AV Limit (dBuV/m)	Margin
					Peak (dBuV/m)	AV (dBuV/m)			
--	H	--	--	--	--	--	--	--	--
--	H	--	--	--	--	--	--	--	--
--	V	--	--	--	--	--	--	--	--
--	V	--	--	--	--	--	--	--	--

Note: This Handheld EUT was tested in 3 orthogonal positions and the worst-case data was presented.
Note: "--" means the mode at least have 20dB margin.

9 BAND EDGE EMISSION

9.1 MEASUREMENT PROCEDURE

1. Set the EUT Work on the top, the bottom operation frequency individually.
2. Set SPA Start or Stop Frequency = Operation Frequency, RBW= 1MHz, VBW= 1MHz.
3. The band edges was measured and recorded.

9.2 TEST SET-UP

The Same as described in section 6.2

9.3 TEST RESULT

TEST PLOT OF BAND ELDG FOR LOW CHANNEL(1Mbps)

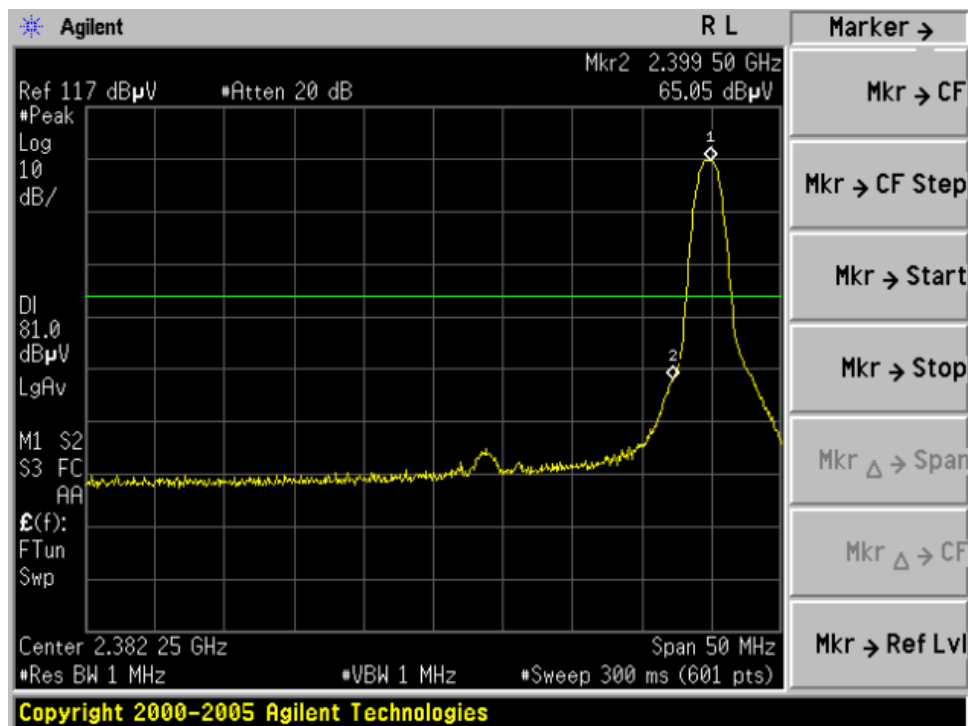

TEST PLOT OF BAND ELDG FOR HIGH CHANNEL(1Mbps)

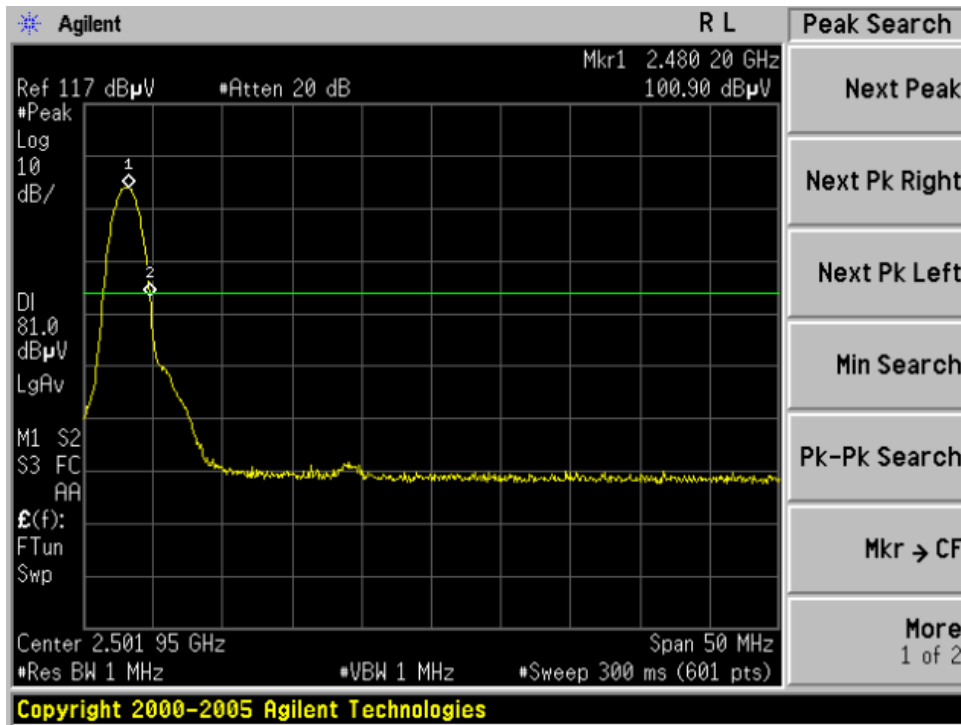

TEST PLOT OF BAND ELDG FOR LOW CHANNEL(2Mbps)

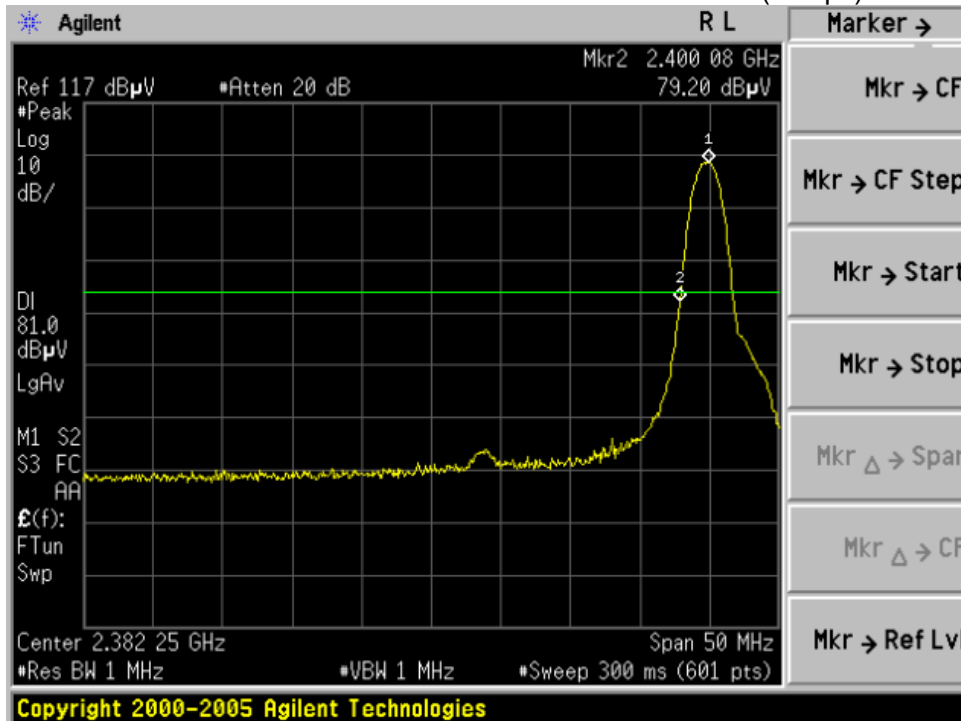

TEST PLOT OF BAND ELDG FOR HIGH CHANNEL(2Mbps)

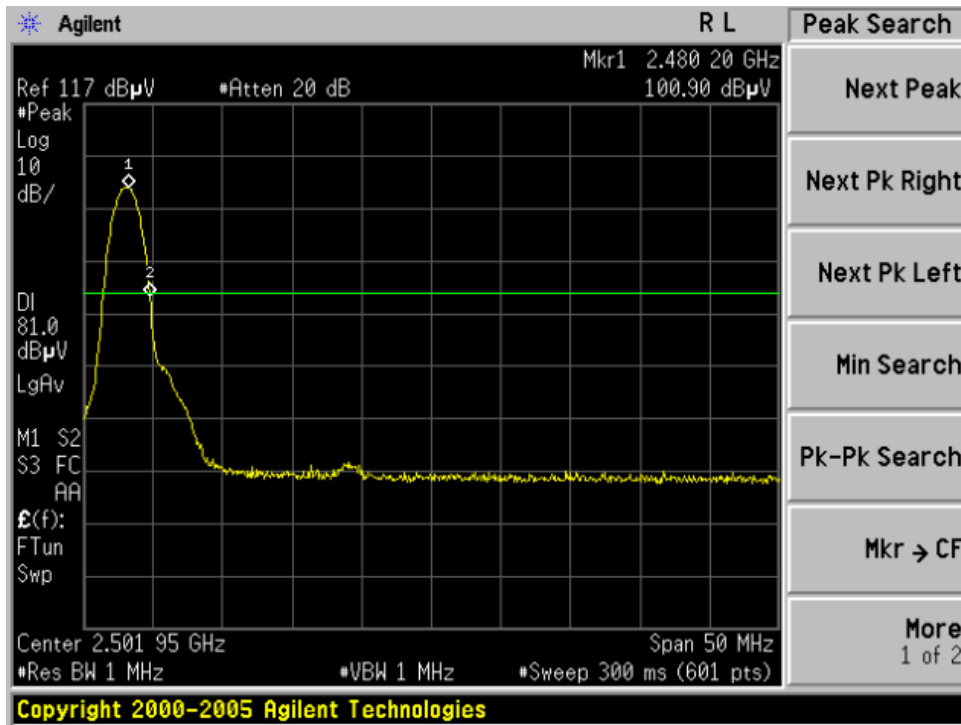

TEST PLOT OF BAND ELDG FOR LOW CHANNEL(3Mbps)

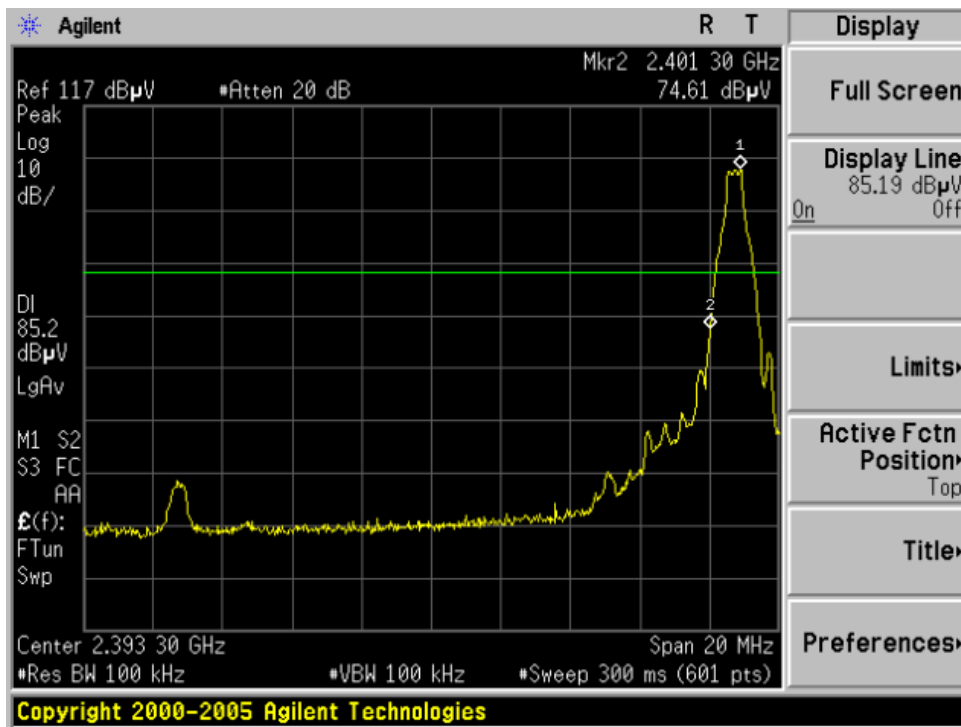

TEST PLOT OF BAND ELDG FOR HIGH CHANNEL(3Mbps)

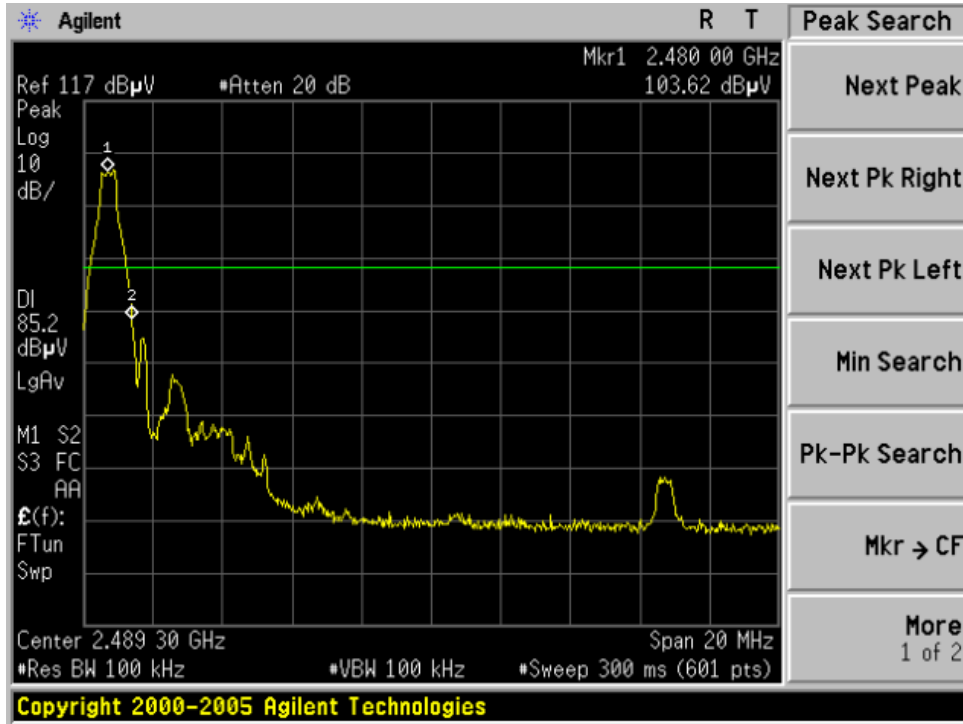

EUT	Bluetooth Headset	Model Name	BTK-718
Temperature	25° C	Relative Humidity	55.4%
Pressure	960hPa	Test Voltage	DC3.7V
Test Mode	BT2402MHZ	Modulation	GFSK

Freq. (MHZ)	Ant.Pol. H/V	Peak Reading (dBuV)	AV Reading (dBuV)	Factor (dB)	Result		Peak Limit (dBuV/m)	AV Limit (dBuV/m)	Margin
					Peak (dBuV/m)	AV (dBuV/m)			
2388.47	H	46.23	35.46	1.33	47.56	36.79	74	54	-17.21
--	H	--	--	--	--	--	--	--	--
2388.56	V	45.37	32.18	1.47	46.84	33.65	74	54	-20.35
--	V	--	--	--	--	--	--	--	--

EUT	Bluetooth Headset	Model Name	BTK-718
Temperature	25° C	Relative Humidity	55.4%
Pressure	960hPa	Test Voltage	DC3.7V
Test Mode	BT2480MHZ	Modulation	GFSK

Freq. (MHZ)	Ant.Pol. H/V	Peak Reading (dBuV)	AV Reading (dBuV)	Factor (dB)	Result		Peak Limit (dBuV/m)	AV Limit (dBuV/m)	Margin
					Peak (dBuV/m)	AV (dBuV/m)			
2483.66	H	42.18	32.58	1.39	43.57	33.97	74	54	-20.03
--	H	--	--	--	--	--	--	--	--
2483.66	V	44.1	35.6	1.39	45.49	36.99	74	54	-17.01
--	V	--	--	--	--	--	--	--	--

Note: "--" means other frequencies at least have 20dB margin.
The other modulation modes comply with standard requirement and at least have 20dB margin.

10 NUMBER OF HOPPING FREQUENCY

10.1 MEASUREMENT PROCEDURE

1. Place the EUT on the table and set it in transmitting mode.
2. Remove the antenna from the EUT and then connect a low RF cable from the antenna port to the spectrum analyzer.
3. Set the spectrum analyzer Start = 2.4GHz Stop = 2.4835GHz
4. Set the Spectrum Analyzer as RBW = 100KHZ

10.2 TEST SETUP (BLOCK DIAGRAM OF CONFIGURATION)

Same as described in section 6.2

1. Conducted Method.

10.3 MEASUREMENT EQUIPMENT USED

The Same as described in section 6.3

10.4 LIMITS AND MEASUREMENT RESULT

TOTAL NO. OF HOPPING CHANNEL	LIMIT (NO. OF CH)	MEASUREMENT (NO. OF CH)	RESULT
	>=15	79	PASS

TEST PLOT FOR NO. OF TOTAL CHANNELS

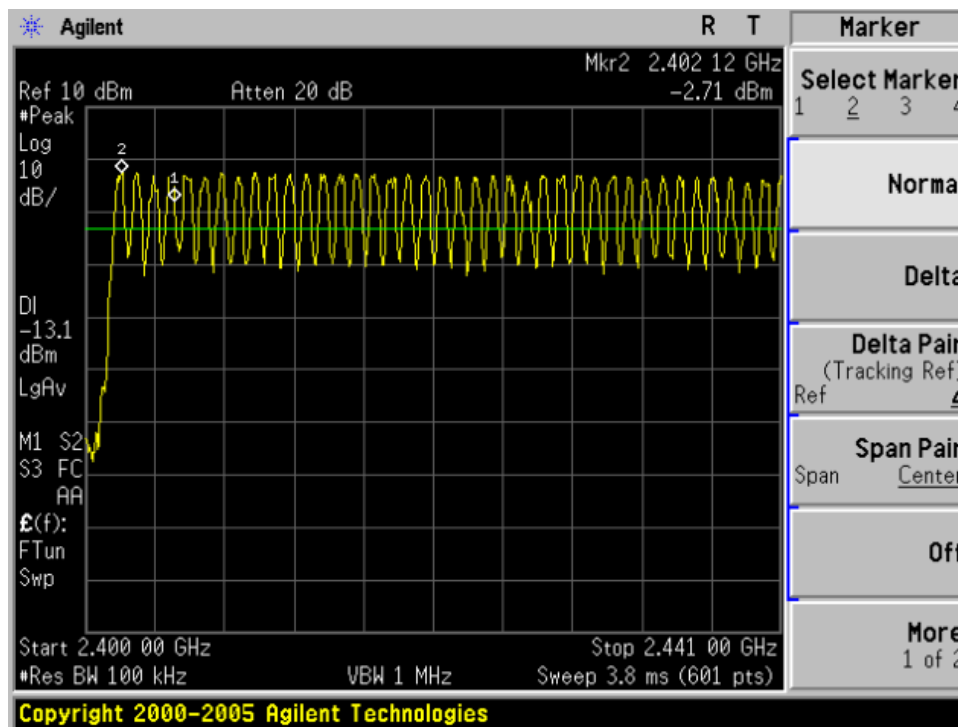

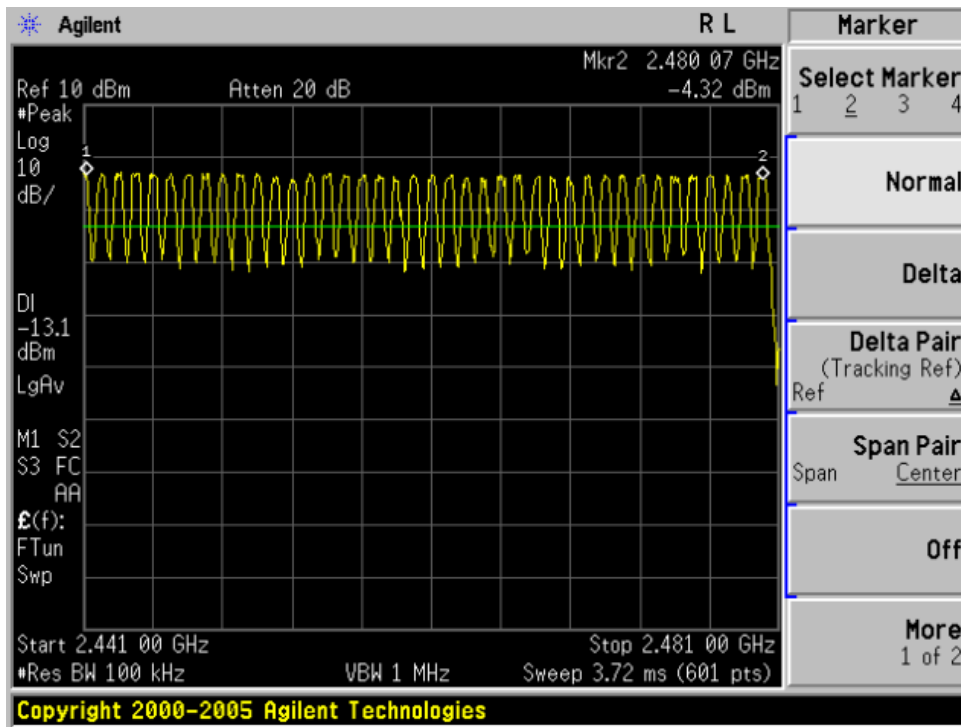

11 TIME OF OCCUPANCY (DWELL TIME)

11.1 MEASUREMENT PROCEDURE

1. Place the EUT on the table and set it in transmitting mode
2. Remove the antenna from the EUT and then connect a low RF cable from the antenna port to the spectrum analyzer
3. Set center frequency of spectrum analyzer = Operating frequency
4. Set the spectrum analyzer as RBW, VBW=1MHz, Span = 0 Hz,

11.2 TEST SETUP (BLOCK DIAGRAM OF CONFIGURATION)

Same as described in section 6.2
Conducted Method

11.3 MEASUREMENT EQUIPMENT USED

The same as described in section 6.3

11.4 LIMITS AND MEASUREMENT RESULT

Low Channel Time
 $2.9 \times (1600/6) / 79 \times 31.6 = 309.33\text{ms}$
Middle Channel Time
 $2.883 \times (1600/6) / 79 \times 31.6 = 307.52\text{ms}$
High Channel Time
 $2.9 \times (1600/6) / 79 \times 31.6 = 309.33\text{ms}$

Bluetooth 1Mbps Test Result

Channel	Time of Pulse for DH5 (ms)	Period Time (s)	Sweep Time (ms)	Limit (ms)
Low	2.9	31.6	309.33	400
Middle	2.883	31.6	307.52	400
High	2.9	31.6	309.33	400

TEST PLOT OF LOW CHANNEL

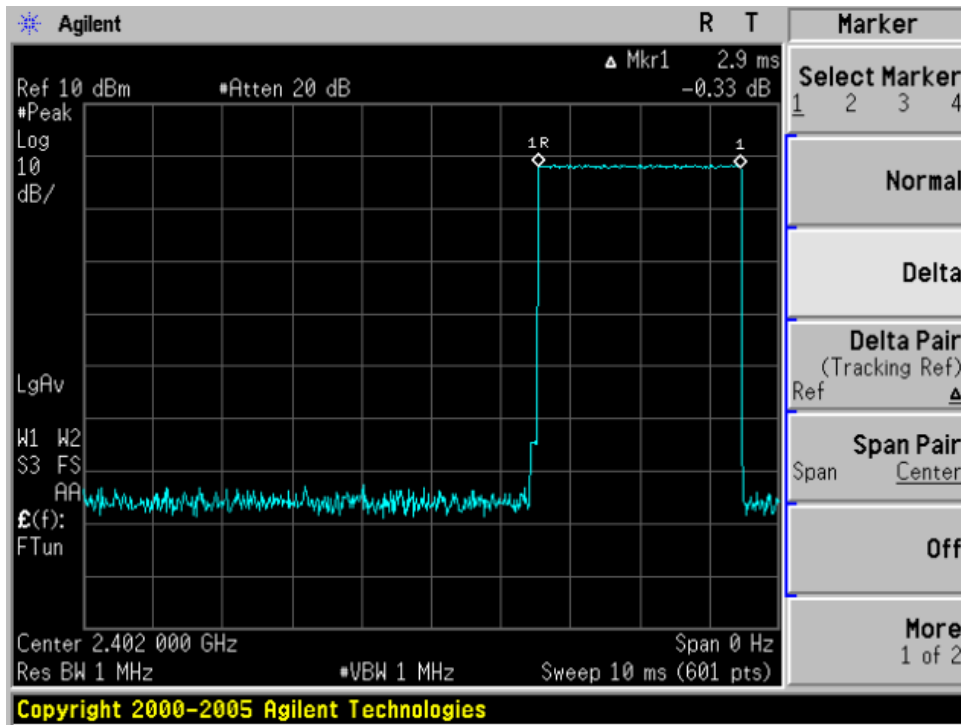

TEST PLOT OF MIDDLE CHANNEL

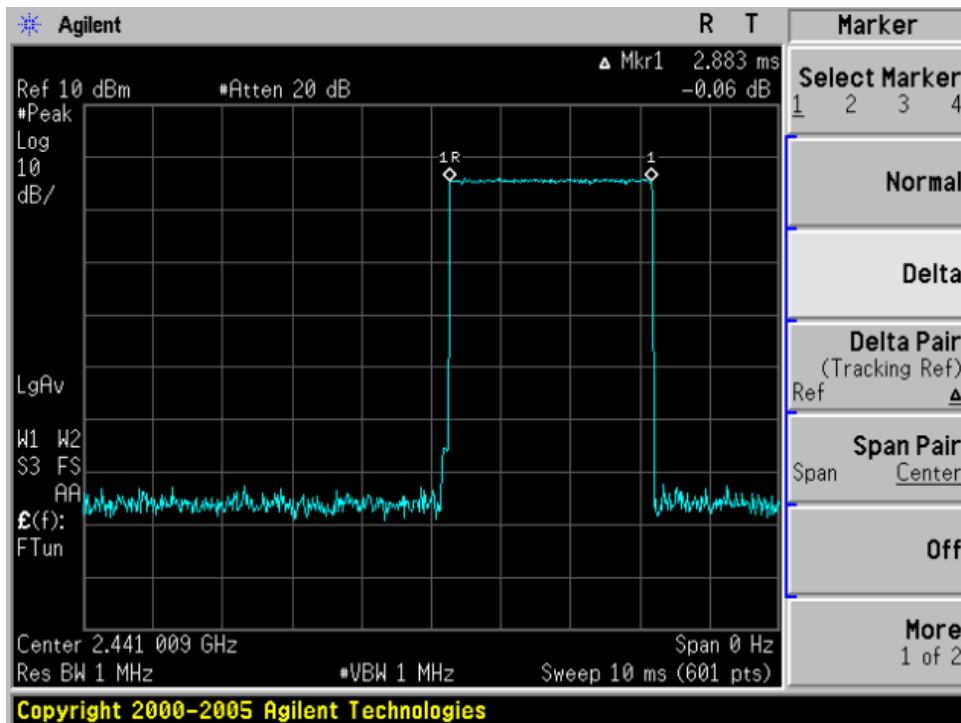

TEST PLOT OF HIGH CHANNEL

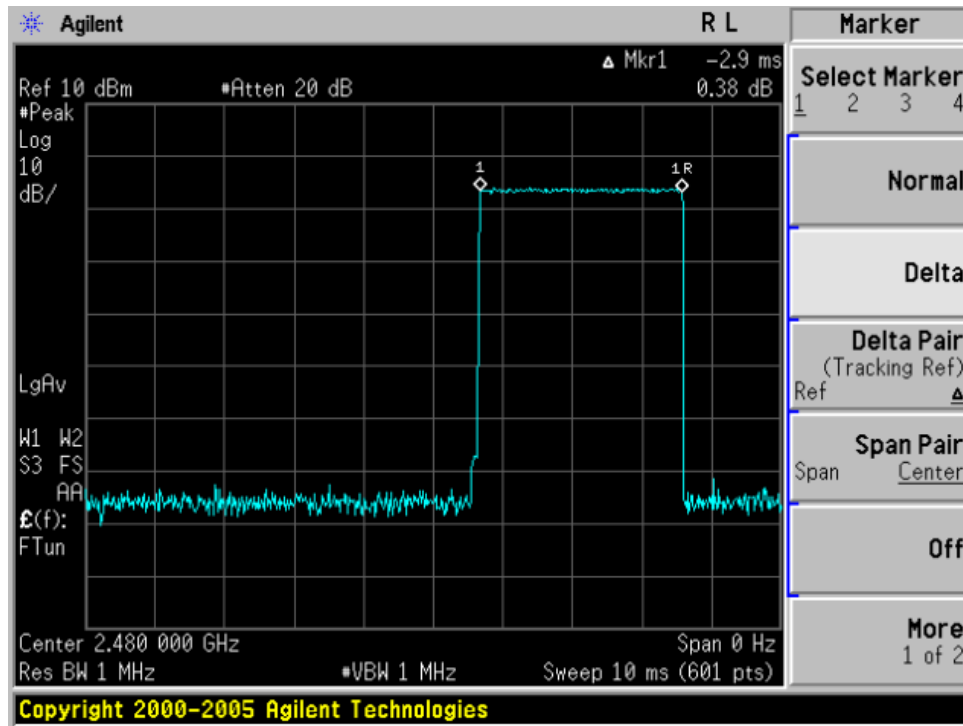

Low Channel Time
 $2.883 \times (1600/6) / 79 \times 31.6 = 307.52\text{ms}$
 Middle Channel Time
 $2.883 \times (1600/6) / 79 \times 31.6 = 307.52\text{ms}$
 High Channel Time
 $2.9 \times (1600/6) / 79 \times 31.6 = 309.33\text{ms}$

Bluetooth 2Mbps Test Result

Channel	Time of Pulse for DH5 (ms)	Period Time (s)	Sweep Time (ms)	Limit (ms)
Low	2.883	31.6	307.52	400
Middle	2.883	31.6	307.52	400
High	2.9	31.6	309.33	400

TEST PLOT OF LOW CHANNEL

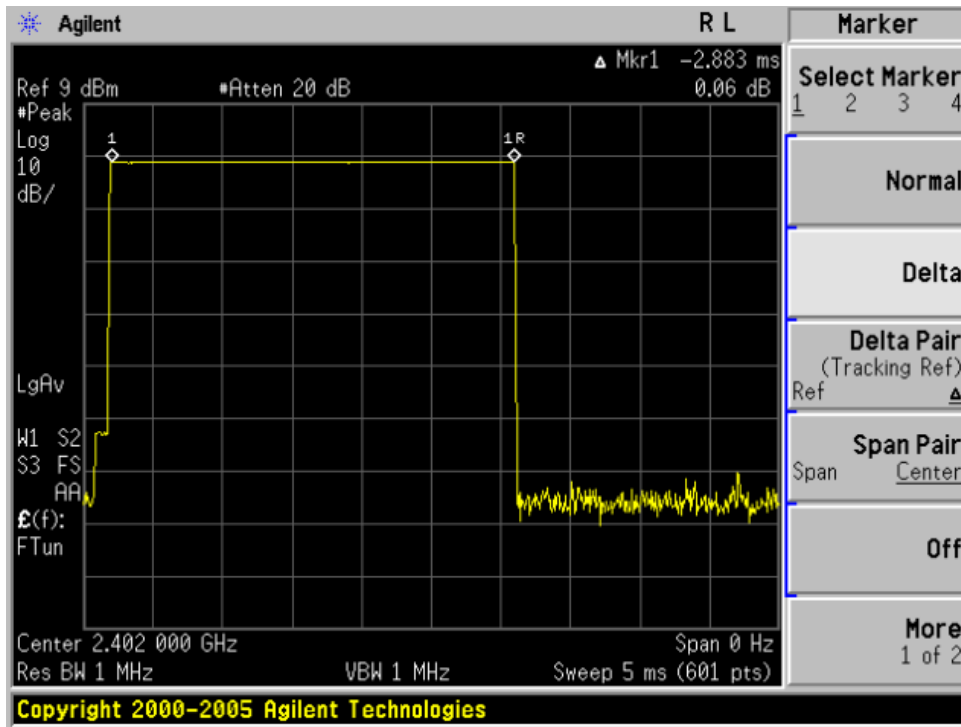

TEST PLOT OF MIDDLE CHANNEL

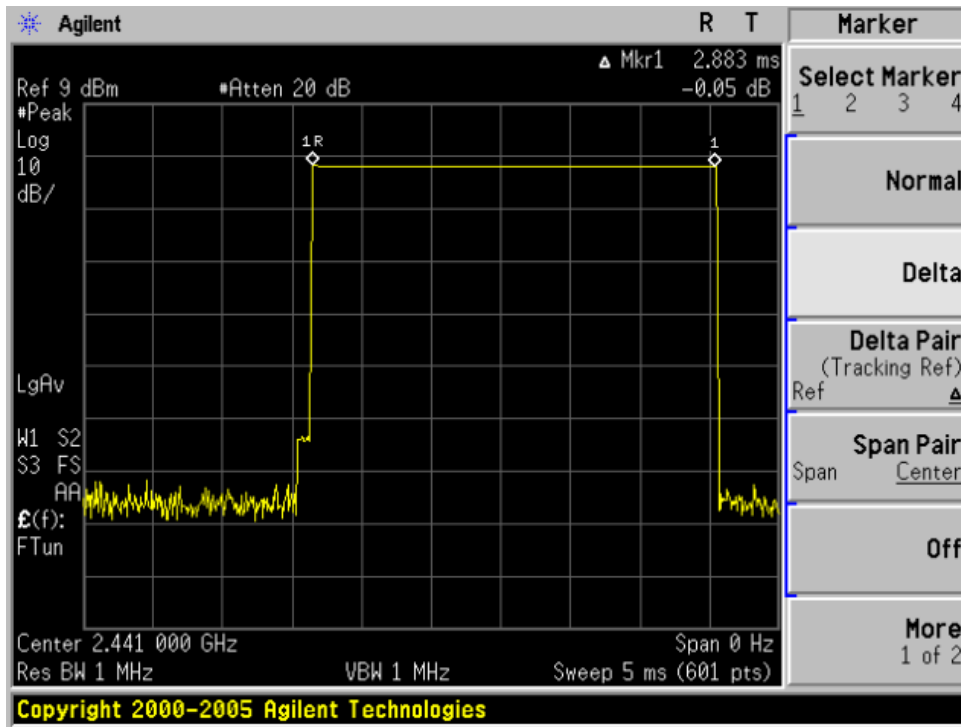

TEST PLOT OF HIGH CHANNEL

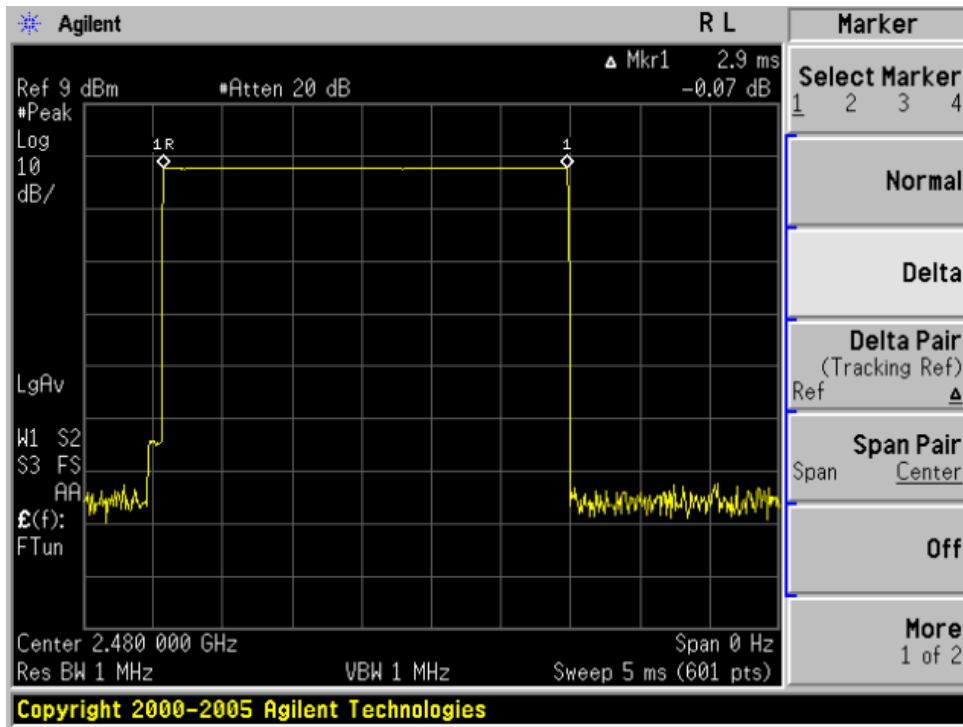

Bluetooth3Mbps Test Result

Channel	Time of Pulse for DH5 (ms)	Period Time (s)	Sweep Time (ms)	Limit (ms)
Low	2.892	31.6	308.48	400
Middle	2.867	31.6	305.81	400
High	2.9	31.6	309.33	400

TEST PLOT OF LOW CHANNEL

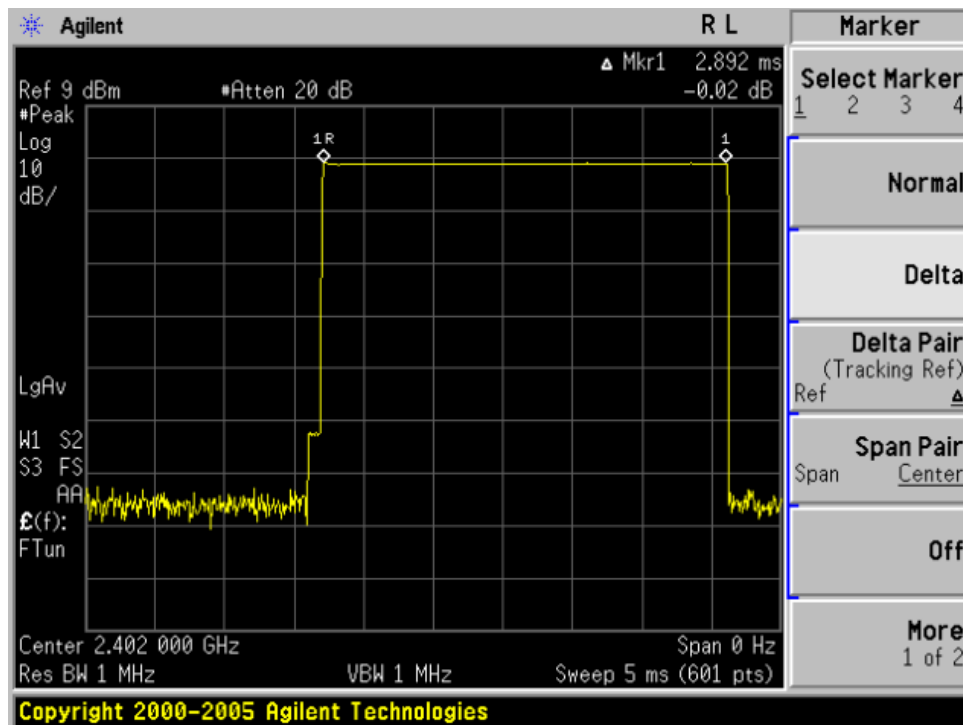

Copyright 2000-2005 Agilent Technologies

TEST PLOT OF MIDDLE CHANNEL

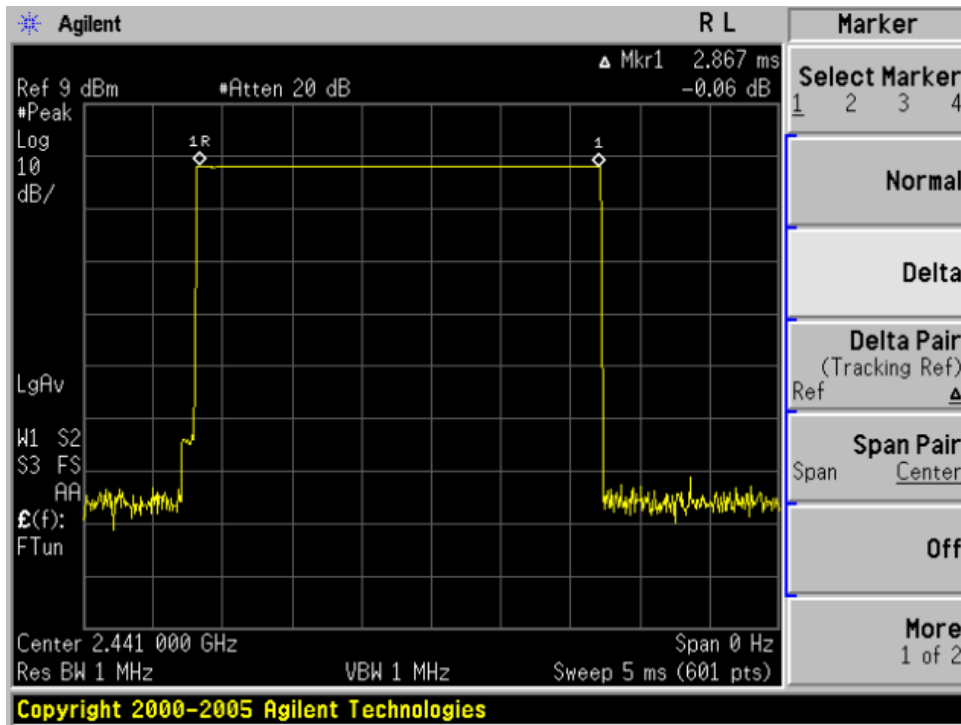

TEST PLOT OF HIGH CHANNEL

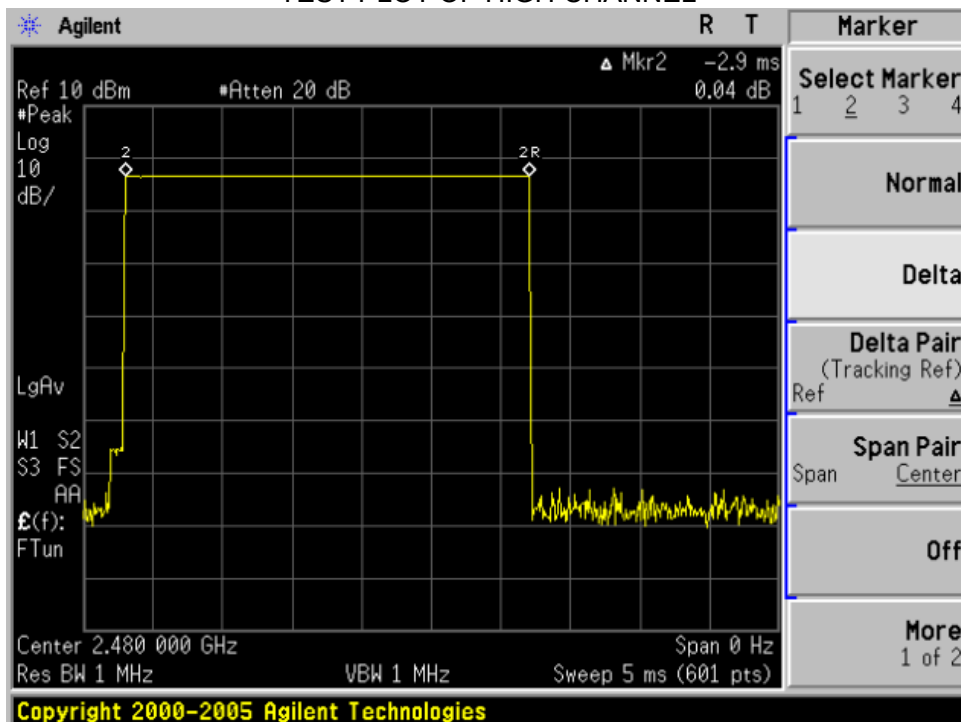

12. FREQUENCY SEPARATION
12.1 MEASUREMENT PROCEDURE

1. Place the EUT on the table and set it in transmitting mode
2. Remove the antenna from the EUT and then connect a low RF cable from the antenna port to the spectrum analyzer
3. Set center frequency of spectrum analyzer = Middle of Operating frequency
4. Set the spectrum analyzer as RBW, VBW=100KHz, Span = 5 MHz,

12.2 TEST SETUP (BLOCK DIAGRAM OF CONFIGURATION)
Same as described in section 6.2

12.3 MEASUREMENT EQUIPMENT USED

The same as described in section 6.3

12.4 LIMITS AND MEASUREMENT RESULT

BLUETOOTH 1MBPS TEST RESULT

CHANNEL	CHANNEL SEPARATION	LIMIT	RESULT
	KHz	KHz	
CH00-CH01	1025	≥ 25 KHz or 2/3 20 dB BW	Pass

TEST PLOT FOR FREQUENCY SEPARATION

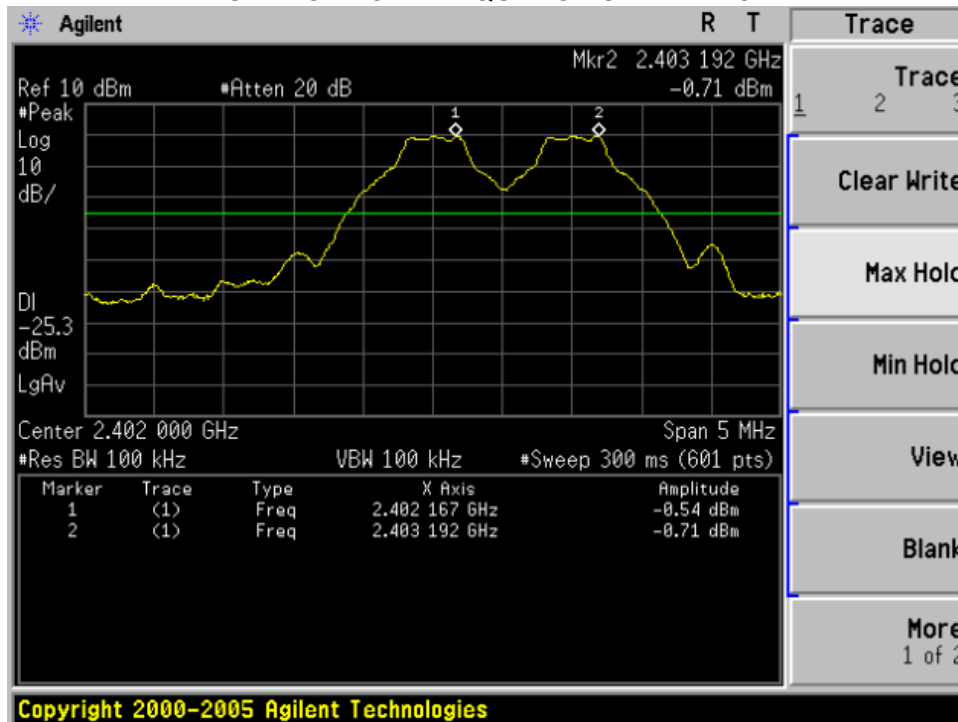

BLUETOOTH 2MBPS TEST RESULT

CHANNEL	CHANNEL SEPARATION	LIMIT	RESULT
	KHz	KHz	
CH00-CH01	1009	>=25 KHz or 2/3 20 dB BW	Pass

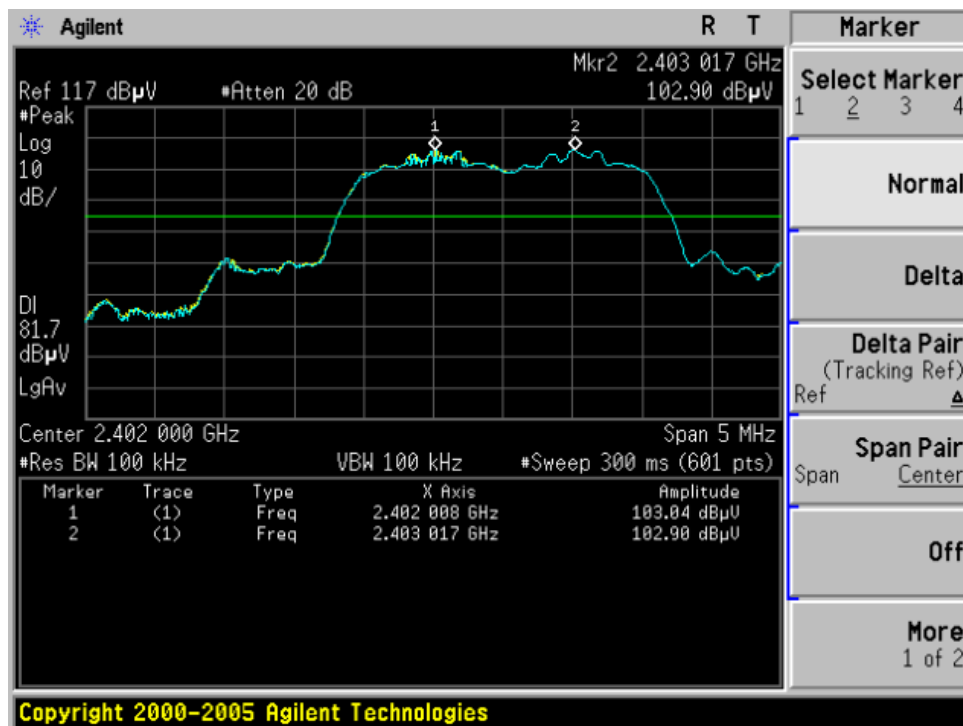

BLUETOOTH 3MBPS TEST RESULT

CHANNEL	CHANNEL SEPARATION	LIMIT	RESULT
	KHz	KHz	
CH00-CH01	1000	>=25 KHz or 2/3 20 dB BW	Pass

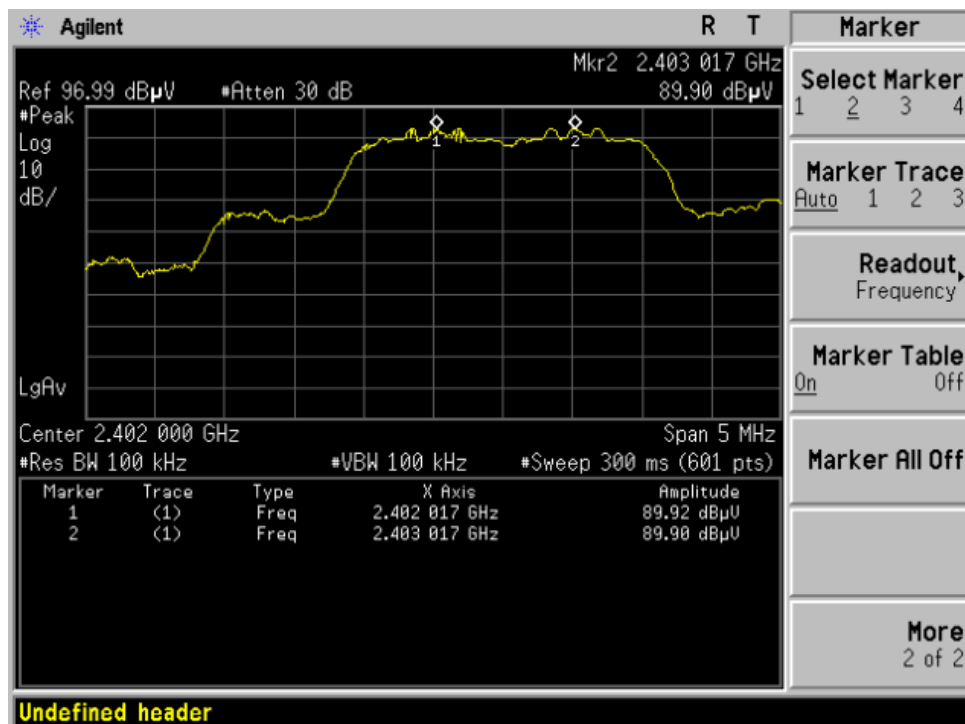

13 FCC LINE CONDUCTED EMISSION TEST

13.1 LIMITS OF LINE CONDUCTED EMISSION TEST

Frequency	Maximum RF Line Voltage	
	Q.P.(dBuV)	Average(dBuV)
150kHz~500kHz	66-56	56-46
500kHz~5MHz	56	46
5MHz~30MHz	60	50

**Note: 1. The lower limit shall apply at the transition frequency.
2. The limit decreases linearly with the logarithm of the frequency in the range 0.15 MHz to 0.50 MHz

13.2 BLOCK DIAGRAM OF LINE CONDUCTED EMISSION TEST

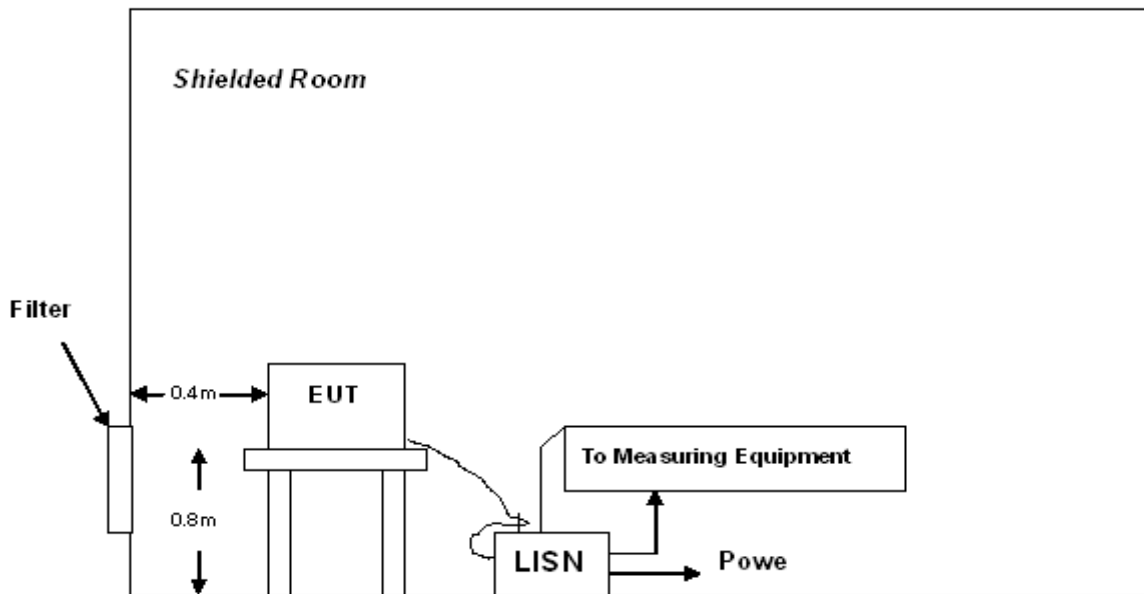

A: Powered through filter

13.3 PRELIMINARY PROCEDURE OF LINE CONDUCTED EMISSION TEST

- 1) The equipment was set up as per the test configuration to simulate typical actual usage per the user's manual. When the EUT is a tabletop system, a wooden table with a height of 0.8 meters is used and is placed on the ground plane as per ANSI C63.4 (see Test Facility for the dimensions of the ground plane used). When the EUT is a floor-standing equipment, it is placed on the ground plane which has a 3-12 mm non-conductive covering to insulate the EUT from the ground plane.
- 2) Support equipment, if needed, was placed as per ANSI C63.4.
- 3) All I/O cables were positioned to simulate typical actual usage as per ANSI C63.4.
- 4) All support equipments received AC120V power from a LISN, if any.
- 5) The EUT received power from support PC
- 6) The test program was started. Emissions were measured on each current carrying line of the EUT using a spectrum Analyzer / Receiver connected to the LISN powering the EUT. The LISN has two monitoring points: Line 1 (Hot Side) and Line 2 (Neutral Side). Two scans were taken: one with Line 1 connected to Analyzer / Receiver and Line 2 connected to a 50 ohm load; the second scan had Line 1 connected to a 50 ohm load and Line 2 connected to the Analyzer / Receiver.
- 7) Analyzer / Receiver scanned from 150 kHz to 30MHz for emissions in each of the test modes.
- 8) During the above scans, the emissions were maximized by cable manipulation.
- 9) The following test mode(s) were scanned during the preliminary test:

Preliminary Line Conducted Emission Test				
Frequency Range Investigated		150 KHz TO 30 MHz		
Mode of operation	Date	Report No.	Data#	Worst Mode
--	--	--	--	<input type="checkbox"/>

Then, the EUT configuration and cable configuration of the above highest emission level were recorded for reference of final testing.

13.4 FINAL PROCEDURE OF LINE CONDUCTED EMISSION TEST

- 1) EUT and support equipment was set up on the test bench as per step 2 of the preliminary test.
- 2) A scan was taken on both power lines, Line 1 and Line 2, recording at least the six highest emissions. Emission frequency and amplitude were recorded into a computer in which correction factors were used to calculate the emission level and compare reading to the applicable limit. If EUT emission level was less -2dB to the A.V. limit in Peak mode, then the emission signal was re-checked using Q.P and Average detector.
- 3) The test data of the worst case condition(s) was reported on the Summary Data page.

13.5 TEST RESULT OF LINE CONDUCTED EMISSION TEST

The USB Port is only charging socket and Owing to the Charger is not a part of EUT,so it's not applicable for the test.

APPENDIX I
PHOTOGRAPHS OF THE EUT

TOP VIEW OF EUT



BOTTOM VIEW OF EUT



RIGHT VIEW OF EUT



LEFT VIEW OF EUT



INTERNAL VIEW OF EUT-1

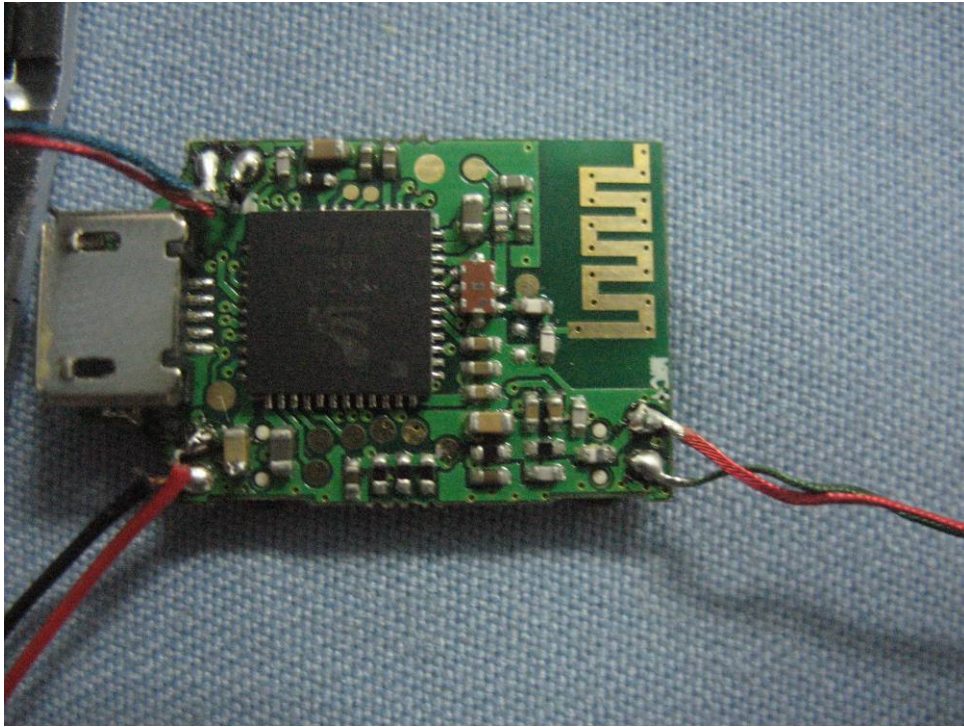

INTERNAL VIEW OF EUT-2

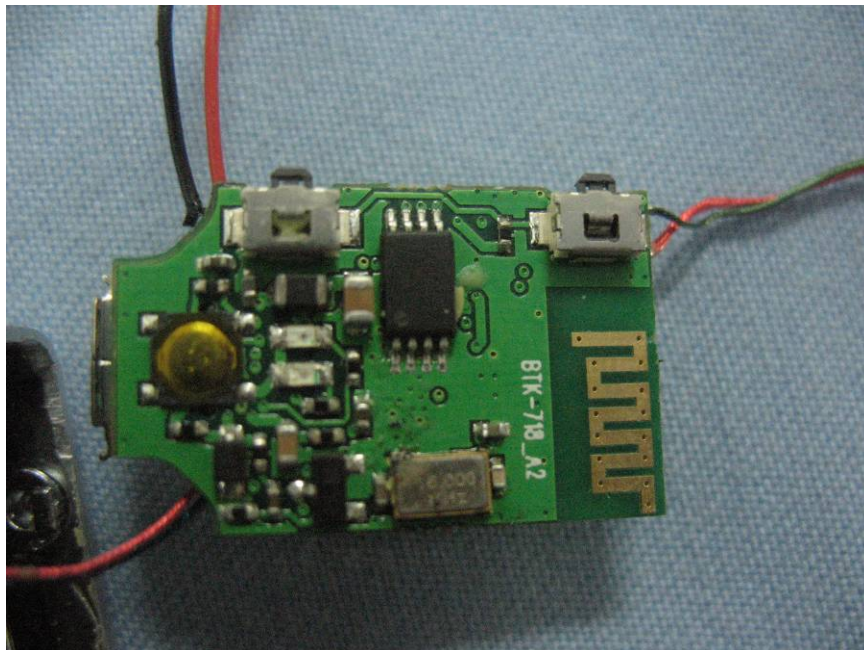

INTERNAL VIEW OF EUT-3

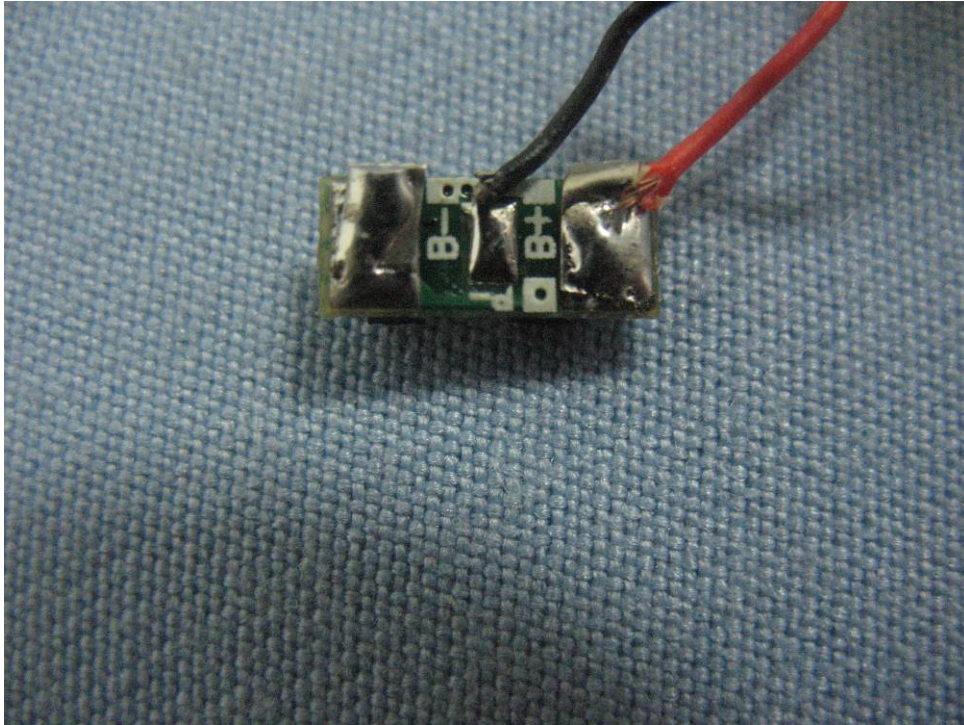

INTERNAL VIEW OF EUT-4

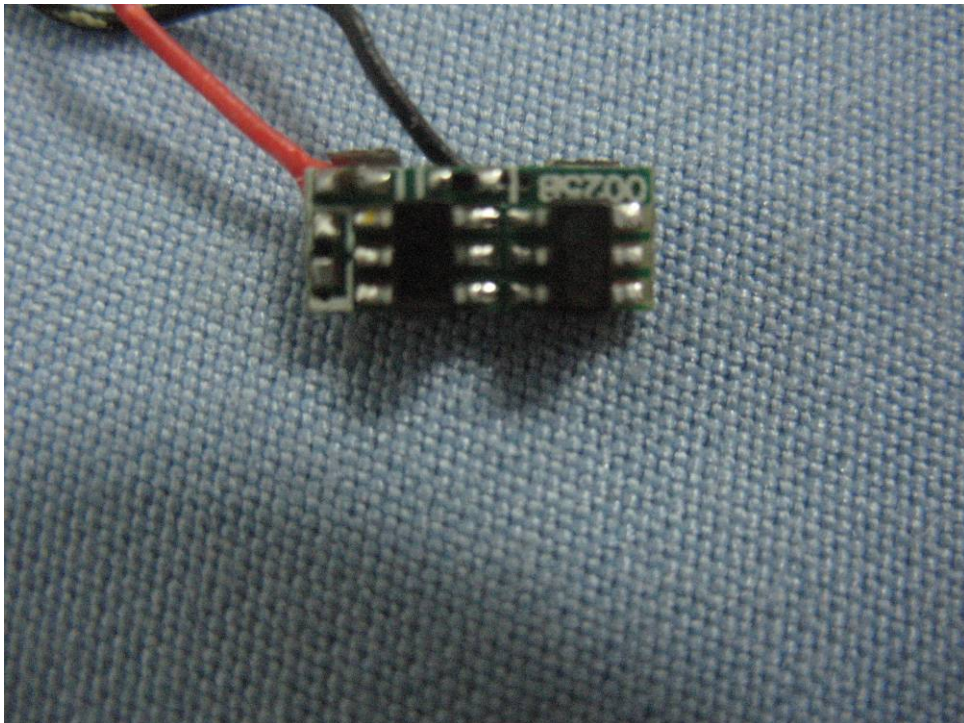

PPENDIX II
PHOTOGRAPHS OF THE TEST SETUP
RADIATED EMISSION TEST SETUP

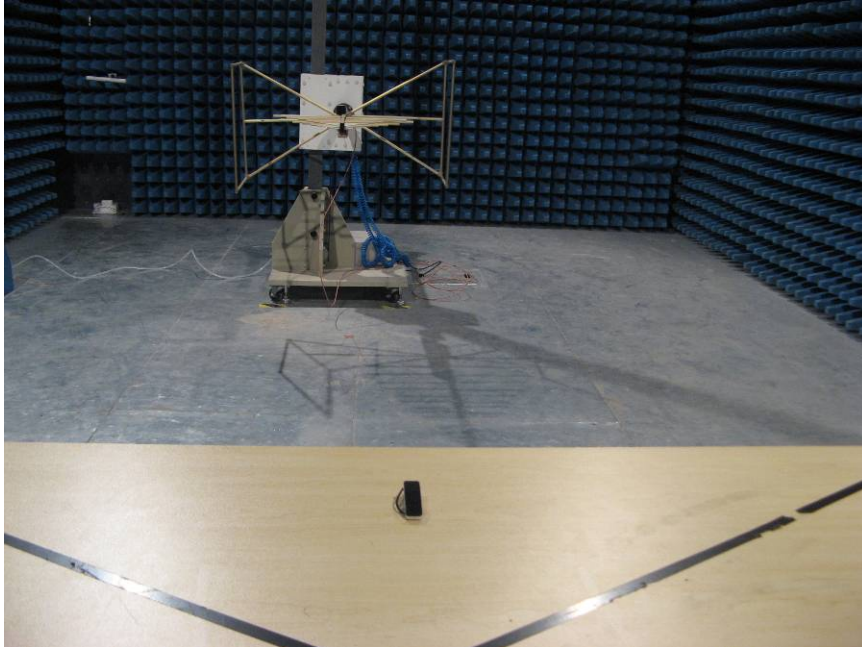

---END OF REPORT---