



**Neutron Engineering Inc.**

# FCC Radio Test Report

## FCC ID: TJ7BTK-503

This report concerns (check one) :  Original Grant  Class II Change

**Issued Date** : Jan. 21, 2013  
**Project No.** : 1212C272  
**Equipment** : Bluetooth speakers  
**Model Name** : BTK-502; BTK-503; BTK-505; BTK-506; BTK-507;  
BTK-508; BTK-509; BTK-28; BTK-30; BTK-31;  
BTK-32; BTK-33; BTK-35; BTK-36  
**Applicant** : ShenZhen SHI KISB Electronic Co., LTD  
**Address** : 3-5F, A Building, Shanghe Industrial Zone,  
Nanchang Road, Bao'an District, Shenzhen, China  
**Manufacturer** : ShenZhen SHI KISB Electronic Co., LTD  
**Address** : 3-5F, A Building, Shanghe Industrial Zone,  
Nanchang Road, Gushu Village, Xixiang Town,  
Bao'an District, Shenzhen, Guangdong, China

**Tested by:**  
Neutron Engineering Inc. EMC Laboratory  
**Date of Receipt:** Jan. 11, 2013  
**Date of Test:**  
Jan. 11, 2013 ~ Jan. 20, 2013

Testing Engineer : David Mao  
(David Mao)

Technical Manager : Leo Hung  
(Leo Hung)

Authorized Signatory : Steven Lu  
(Steven Lu)

**Neutron Engineering Inc.**

**No.3, Jinshagang 1st Road, ShiXia, Dalang  
Town, Dong Guan, China.  
TEL : (0769) 8318-3000 FAX : (0769) 8319-6000**



**Declaration**

**Neutron** represents to the client that testing is done in accordance with standard procedures as applicable and that test instruments used has been calibrated with the standards traceable to National Measurement Laboratory (**NML**) of **R.O.C.**, or National Institute of Standards and Technology (**NIST**) of **U.S.A.**

**Neutron's** reports apply only to the specific samples tested under conditions. It is manufacture's responsibility to ensure that additional production units of this model are manufactured with the identical electrical and mechanical components. **Neutron** shall have no liability for any declarations, inferences or generalizations drawn by the client or others from **Neutron** issued reports.

**Neutron's** reports must not be used by the client to claim product endorsement by the authorities or any agency of the Government.

This report is the confidential property of the client. As a mutual protection to the clients, the public and **Neutron-self**, extracts from the test report shall not be reproduced except in full with **Neutron's** authorized written approval.

**Neutron's** laboratory quality assurance procedures are in compliance with the **ISO Guide 17025** requirements, and accredited by the conformity assessment authorities listed in this test report.

**Limitation**

For the use of the authority's logo is limited unless the Test Standard(s)/Scope(s)/Item(s) mentioned in this test report is (are) included in the conformity assessment authorities acceptance respective.



<b>Table of Contents</b>	<b>Page</b>
<b>1 . CERTIFICATION</b>	<b>5</b>
<b>2 . SUMMARY OF TEST RESULTS</b>	<b>6</b>
2.1 TEST FACILITY	7
2.2 MEASUREMENT UNCERTAINTY	7
<b>3 . GENERAL INFORMATION</b>	<b>8</b>
3.1 GENERAL DESCRIPTION OF EUT	8
3.2 DESCRIPTION OF TEST MODES	10
3.3 TABLE OF PARAMETERS OF TEXT SOFTWARE SETTING	11
3.4 BLOCK DIAGRAM SHOWING THE CONFIGURATION OF SYSTEM TESTED	12
3.5 DESCRIPTION OF SUPPORT UNITS	13
<b>4 . EMC EMISSION TEST</b>	<b>14</b>
4.1 CONDUCTED EMISSION MEASUREMENT	14
4.1.1 POWER LINE CONDUCTED EMISSION LIMITS	14
4.1.2 MEASUREMENT INSTRUMENTS LIST AND SETTING	14
4.1.3 TEST PROCEDURE	15
4.1.4 DEVIATION FROM TEST STANDARD	15
4.1.5 TEST SETUP	15
4.1.6 EUT OPERATING CONDITIONS	15
4.1.7 TEST RESULTS	16
4.2 RADIATED EMISSION MEASUREMENT	21
4.2.1 RADIATED EMISSION LIMITS	21
4.2.2 MEASUREMENT INSTRUMENTS LIST AND SETTING	22
4.2.3 TEST PROCEDURE	23
4.2.4 DEVIATION FROM TEST STANDARD	23
4.2.5 TEST SETUP	24
4.2.6 EUT OPERATING CONDITIONS	25
4.2.8 TEST RESULTS-BETWEEN 30MHZ AND 1000MHZ	27
4.2.7 TEST RESULTS (ABOVE 1000 MHZ)	34
<b>5 . BANDWIDTH TEST</b>	<b>46</b>
5.1 APPLIED PROCEDURES / LIMIT	46
5.1.1 MEASUREMENT INSTRUMENTS LIST	46
5.1.2 TEST PROCEDURE	46
5.1.3 DEVIATION FROM STANDARD	46
5.1.4 TEST SETUP	46
5.1.5 EUT OPERATION CONDITIONS	46
5.1.6 TEST RESULTS	47
<b>6 . MAXIMUM OUTPUT POWER TEST</b>	<b>49</b>



Table of Contents	Page
<b>6.1 APPLIED PROCEDURES / LIMIT</b>	<b>49</b>
6.1.1 MEASUREMENT INSTRUMENTS LIST	49
6.1.2 TEST PROCEDURE	49
6.1.3 DEVIATION FROM STANDARD	49
6.1.4 TEST SETUP	49
6.1.5 EUT OPERATION CONDITIONS	49
6.1.6 TEST RESULTS	50
<b>7 . ANTENNA CONDUCTED SPURIOUS EMISSION</b>	<b>51</b>
7.1 APPLIED PROCEDURES / LIMIT	51
7.1.1 MEASUREMENT INSTRUMENTS LIST	51
7.1.2 TEST PROCEDURE	51
7.1.3 DEVIATION FROM STANDARD	51
7.1.4 TEST SETUP	51
7.1.5 EUT OPERATION CONDITIONS	51
7.1.6 TEST RESULTS	52
<b>8 . POWER SPECTRAL DENSITY TEST</b>	<b>57</b>
8.1 APPLIED PROCEDURES / LIMIT	57
8.1.1 MEASUREMENT INSTRUMENTS LIST	57
8.1.2 TEST PROCEDURE	57
8.1.3 DEVIATION FROM STANDARD	57
8.1.4 TEST SETUP	57
8.1.5 EUT OPERATION CONDITIONS	57
8.1.6 TEST RESULTS	58
<b>9 . EUT TEST PHOTO</b>	<b>60</b>



## 1. CERTIFICATION

Equipment : Bluetooth speakers  
Brand Name : KISS; BTK  
Model Name : BTK-502; BTK-503; BTK-505; BTK-506; BTK-507; BTK-508; BTK-509; BTK-28;  
BTK-30; BTK-31; BTK-32; BTK-33; BTK-35; BTK-36  
Applicant : ShenZhen SHI KISB Electronic Co., LTD  
Factory : ShenZhen SHI KISB Electronic Co., LTD  
Address : 3-5F, A Building, Shanghe Industrial Zone, Nanchang Road, Gushu Village,  
Xixiang Town, Bao'an District, Shenzhen, Guangdong, China  
Date of Test : Jan. 11, 2013 ~ Jan. 20, 2013  
Test Item : ENGINEERING SAMPLE  
Standards : FCC Part15, Subpart C(15.247) / ANSI C63.4-2009

The above equipment has been tested and found compliance with the requirement of the relative standards by Neutron Engineering Inc. EMC Laboratory.

The test data, data evaluation, and equipment configuration contained in our test report (Ref No. NEI-FCCP-2-1212C272) were obtained utilizing the test procedures, test instruments, test sites that has been accredited by the Authority of NVLAP and TAF according to the ISO-17025 quality assessment standard and technical standard(s).



## 2. SUMMARY OF TEST RESULTS

Test procedures according to the technical standards:

FCC Part15 (15.247) , Subpart C				
Standard	Section	Test Item	Judgment	Remark
	15.207	Conducted Emission	PASS	
	15.247(d)	Antenna conducted Spurious Emission	PASS	
	15.247(a)(2)	6dB Bandwidth	PASS	
	15.247(b)(3)	Peak Output Power	PASS	
	15.209/15.205	Radiated Spurious Emission	PASS	
	15.247(e)	Power Spectral Density	PASS	
	15.203	Antenna Requirement	PASS	

**NOTE:**

- (1) "N/A" denotes test is not applicable in this test report.
- (2) The test follows FCC KDB Publication No. 558074 D01 DTS Meas Guidance v02 (Measurement Guidelines of DTS)



**2.1 TEST FACILITY**

The test facilities used to collect the test data in this report is **DG-C02/DG-CB03** at the location of No.3,Jinshagang 1st Road, ShiXia, Dalang Town, Dong Guan, China.523792  
 Neutron's test firm number is 319330

**2.2 MEASUREMENT UNCERTAINTY**

Where relevant, the following measurement uncertainty levels have been estimated for tests performed on the EUT as specified in CISPR 16-4-2:

The reported uncertainty of measurement  $y \pm U$ , where expanded uncertainty U is based on a standard uncertainty multiplied by a coverage factor of  $k=2$ , providing a level of confidence of approximately 95 %.

A. Conducted Measurement :

Test Site	Method	Measurement Frequency Range	U , (dB)	NOTE
DG-C02	CISPR	150 KHz ~ 30MHz	1.94	

B. Radiated Measurement :

Test Site	Method	Measurement Frequency Range	Ant. H / V	U , (dB)	NOTE
DG-CB03	CISPR	30MHz ~ 200MHz	V	3.82	
		30MHz ~ 200MHz	H	3.60	
		200MHz ~ 1,000MHz	V	3.86	
		200MHz ~ 1,000MHz	H	3.94	
		1GHz~18GHz	V	3.12	
		1GHz~18GHz	H	3.68	
		18GHz~40GHz	V	4.15	
		18GHz~40GHz	H	4.14	



**3. GENERAL INFORMATION**

**3.1 GENERAL DESCRIPTION OF EUT**

Equipment	Bluetooth speakers	
Brand Name	KISS; BTK	
Model Name	BTK-502; BTK-503; BTK-505; BTK-506; BTK-507; BTK-508; BTK-509; BTK-28; BTK-30; BTK-31; BTK-32; BTK-33; BTK-35; BTK-36	
Model Difference	Only difference is model name.	
Product Description	The EUT is a Bluetooth speakers.	
	Operation Frequency:	2402~2480 MHz
	Modulation Technology:	GFSK(1Mbps)
	Bit Rate of Transmitter	
	Number of Channel	40CH
	Antenna Designation:	Please see note 3.(Page 9)
	Antenna Gain(Peak)	
	Output Power:	3.79 dBm (1Mbps)
	Based on the application, features, or specification exhibited in User's Manual, the EUT is considered as an ITE/Computing Device. More details of EUT technical specification, please refer to the User's Manual.	
Power Source	#1 DC voltage supplied from rechargeable polymer lithium battery. #2 DC voltage supplied from USB power charge.	
Power Rating	#1 DC 3.7V #2 I/P AC 120V/60Hz O/P DC 5V	
Connecting I/O Port(s)	Please refer to the User's Manual	

**Note:**

1. For a more detailed features description, please refer to the manufacturer's specifications or the User's Manual.





3.

<b>Channel List</b>			
Channel	Frequency (MHz)	Channel	Frequency (MHz)
00	2402	20	2442
01	2404	21	2444
02	2406	22	2446
03	2408	23	2448
04	2410	24	2450
05	2412	25	2452
06	2414	26	2454
07	2416	27	2456
08	2418	28	2458
09	2420	29	2460
10	2422	30	2462
11	2424	31	2464
12	2426	32	2466
13	2428	33	2468
14	2430	34	2470
15	2432	35	2472
16	2434	36	2474
17	2436	37	2476
18	2438	38	2478
19	2440	39	2480

3. Table for Filed Antenna

Ant.	Brand	Model Name	Antenna Type	Connector	Gain (dBi)	Note
1	N/A	N/A	Chip Antenna	N/A	0.81	



**3.2 DESCRIPTION OF TEST MODES**

To investigate the maximum EMI emission characteristics generates from EUT, the test system was pre-scanning tested base on the consideration of following EUT operation mode or test configuration mode which possible have effect on EMI emission level. Each of these EUT operation mode(s) or test configuration mode(s) mentioned above was evaluated respectively.

Pretest Mode	Description
Mode 1	TX Mode <b>NOTE (1)</b>
Mode 2	Bluetooth

The EUT system operated these modes were found to be the worst case during the pre-scanning test as following:

<b>For Conducted Test</b>	
Final Test Mode	Description
Mode 2	Bluetooth

<b>For Radiated Test</b>	
Final Test Mode	Description
Mode 1	TX Mode <b>NOTE (1)</b>

Note:

(1) The measurements are performed at the high, middle, low available channels.



**3.3 TABLE OF PARAMETERS OF TEXT SOFTWARE SETTING**

During testing channel & power controlling software provided by the customer was used to control the operating channel as well as the output power level. The RF output power selection is for the setting of RF output power expected by the customer and is going to be fixed on the firmware of the final end product power parameters of WLAN

Test software version	CSR		
Frequency	2402MHz	2440 MHz	2480MHz
GFSK-1Mbps	56	56	56



### 3.4 BLOCK DIAGRAM SHOWING THE CONFIGURATION OF SYSTEM TESTED

Conducted:

Bluetooth

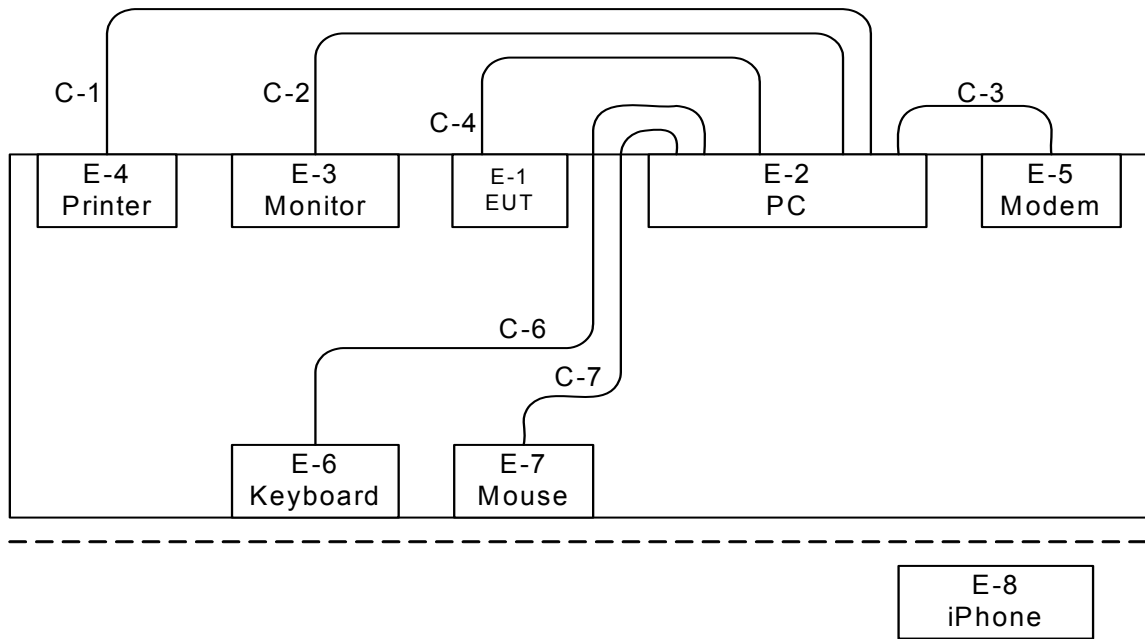

Radiated:

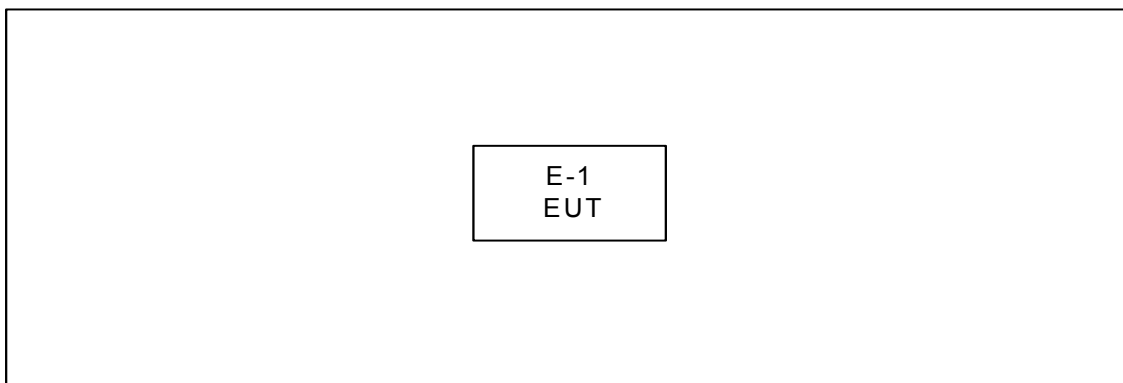



**3.5 DESCRIPTION OF SUPPORT UNITS**

The EUT has been tested as an independent unit together with other necessary accessories or support units. The following support units or accessories were used to form a representative test configuration during the tests.

Item	Equipment	Mfr/Brand	Model/Type No.	FCC ID	Series No.	Note
E-1	Bluetooth speakers	KISS	BTK-502	TJ7BTK-503	N/A	EUT
E-2	PC	Dell	745	DOC	G7K832X	
E-3	LCD monitor	Dell	E177FPc	DOC	CNOFJ179-64180-6AG-1WNS	
E-4	Printer	SII	DPU-414	DOC	3018507 B	
E-5	Modem	ACEEX	DM-1414V	IFAXDm1414	0603002131	
E-6	USB Keyboard	Dell	L100	DOC	CNORH6596589071T08NE	
E-7	USB Keyboard	Dell	L100	DOC	CNORH6596589071T08NE	
E-8	IPHONE 3	APPLE	A1241	DOC	BCGA1241	

Item	Shielded Type	Ferrite Core	Length	Note
C-1	YES	NO	1.5m	
C-2	YES	YES	1.5m	
C-3	YES	NO	1.5m	
C-4	NO	NO	0.85m	
C-5	NO	NO	1m	
C-6	NO	NO	1.9m	
C-7	NO	NO	1.9m	

Note:

- (1) The support equipment was authorized by Declaration of Confirmation.
- (2) For detachable type I/O cable should be specified the length in m in 『Length』 column.



**4. EMC EMISSION TEST**

**4.1 CONDUCTED EMISSION MEASUREMENT**

**4.1.1 POWER LINE CONDUCTED EMISSION Limits (Frequency Range 150KHz-30MHz)**

FREQUENCY (MHz)	Class A (dBuV)		Class B (dBuV)		Standard
	Quasi-peak	Average	Quasi-peak	Average	
0.15 -0.5	79.00	66.00	66 - 56 *	56 - 46 *	CISPR
0.50 -5.0	73.00	60.00	56.00	46.00	CISPR
5.0 -30.0	73.00	60.00	60.00	50.00	CISPR

0.15 -0.5	79.00	66.00	66 - 56 *	56 - 46 *	FCC
0.50 -5.0	73.00	60.00	56.00	46.00	FCC
5.0 -30.0	73.00	60.00	60.00	50.00	FCC

Note:

- (1) The tighter limit applies at the band edges.
- (2) The limit of " \* " marked band means the limitation decreases linearly with the logarithm of the frequency in the range.

**4.1.2 MEASUREMENT INSTRUMENTS LIST AND SETTING**

Item	Kind of Equipment	Manufacturer	Type No.	Serial No.	Calibrated Until
1	LISN	EMCO	3816/2	00052765	May.04.2013
2	LISN	R&S	ENV216	100087	May.04.2013
3	Test Cable	N/A	C_17	N/A	Mar.28.2013
4	EMI TEST RECEIVER	R&S	ESCS30	826547/022	May.04.2013
5	50Ω Terminator	SHX	TF2-3G-A	08122902	May.04.2013

Remark: "N/A" denotes no model name, serial no. or calibration specified.

All calibration period of Equipment List is One Year.

The following table is the setting of the receiver

Receiver Parameters	Setting
Attenuation	10 dB
Start Frequency	0.15 MHz
Stop Frequency	30 MHz
IF Bandwidth	9 kHz

#### 4.1.3 TEST PROCEDURE

- The EUT was placed 0.8 meters from the horizontal ground plane with EUT being connected to the power mains through a line impedance stabilization network (LISN). All other support equipments powered from additional LISN(s). The LISN provide 50 Ohm/ 50uH of coupling impedance for the measuring instrument.
- Interconnecting cables that hang closer than 40 cm to the ground plane shall be folded back and forth in the center forming a bundle 30 to 40 cm long.
- I/O cables that are not connected to a peripheral shall be bundled in the center. The end of the cable may be terminated, if required, using the correct terminating impedance. The overall length shall not exceed 1 m.
- LISN at least 80 cm from nearest part of EUT chassis.
- For the actual test configuration, please refer to the related Item –EUT Test Photos.

#### 4.1.4 DEVIATION FROM TEST STANDARD

No deviation

#### 4.1.5 TEST SETUP

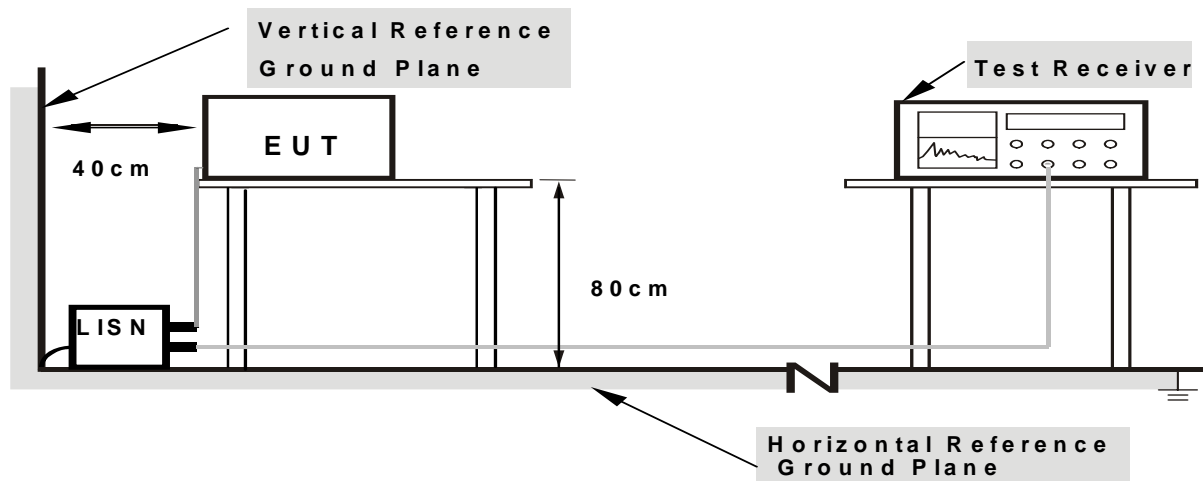

- Note:**
- Support units were connected to second LISN.
  - Both of LISNs (AMN) are 80 cm from EUT and at least 80 cm from other units and other metal planes

#### 4.1.6 EUT OPERATING CONDITIONS

The EUT was configured for testing in a typical fashion (as a customer would normally use it). The EUT has been programmed to continuously transmit during test. This operating condition was tested and used to collect the included data.

The EUT was programmed to be in continuously transmitting mode.



#### 4.1.7 TEST RESULTS

##### Remark

- (1) Reading in which marked as QP means measurements by using are Quasi-Peak Mode with Detector BW=9KHz ; SPA setting in RBW=10KHz,VBW =10KHz, Swp. Time = 0.3 sec./MHz. Reading in which marked as AV means measurements by using are Average Mode with instrument setting in RBW=10KHz,VBW=10KHz, Swp. Time =0.3 sec./MHz.
- (2) All readings are QP Mode value unless otherwise stated AVG in column of Note. If the QP Mode Measured value compliance with the QP Limits and lower than AVG Limits, the EUT shall be deemed to meet both QP & AVG Limits and then only QP Mode was measured, but AVG Mode didn't perform. In this case, a " \* " marked in AVG Mode column of Interference Voltage Measured.
- (3) Peak value recorded in table if the margin from QP Limit is larger than 2dB, otherwise, QP value is recorded.





EUT:	Bluetooth speakers	Model Name :	BTK-502
Temperature:	24 °C	Relative Humidity:	60 %
Test Power:	AC 120V/60Hz	Phase:	Line
Test Mode:	Bluetooth		

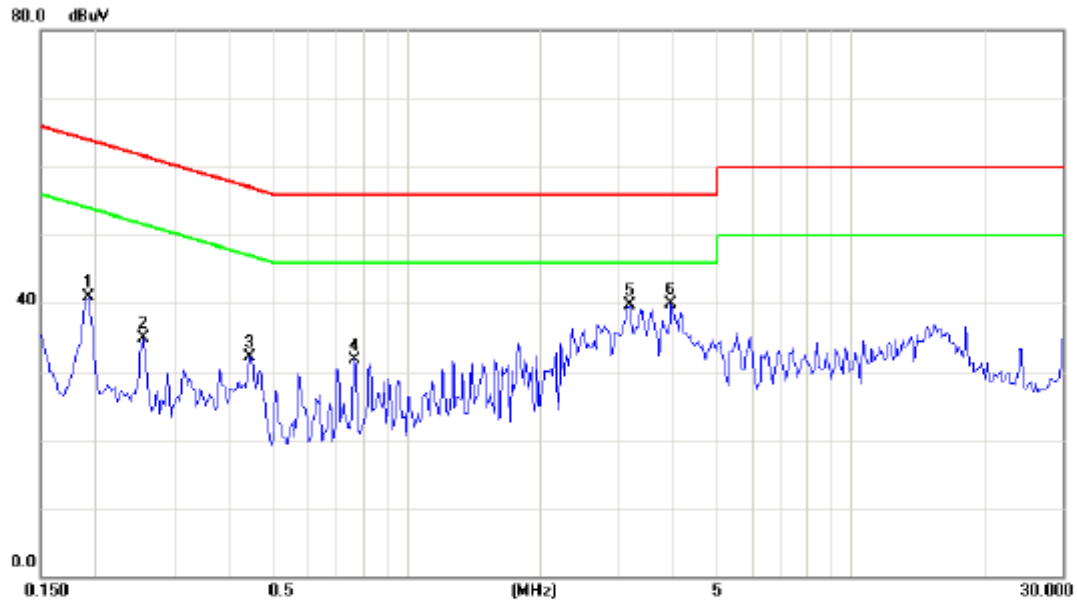

No.	Mk.	Freq. MHz	Reading Level dBuV	Correct Factor dB	Measure- ment dBuV	Limit dBuV	Over dB	Detector	Comment
1		0.1930	31.13	9.69	40.82	63.91	-23.09	peak	
2		0.2555	25.30	9.68	34.98	61.58	-26.60	peak	
3		0.4430	22.40	9.71	32.11	57.01	-24.90	peak	
4		0.7632	22.09	9.71	31.80	56.00	-24.20	peak	
5		3.1836	29.97	9.80	39.77	56.00	-16.23	peak	
6	*	3.9531	30.04	9.82	39.86	56.00	-16.14	peak	



EUT:	Bluetooth speakers	Model Name :	BTK-502
Temperature:	24 °C	Relative Humidity:	60 %
Test Power:	AC 120V/60Hz	Phase:	Neutral
Test Mode:	Bluetooth		

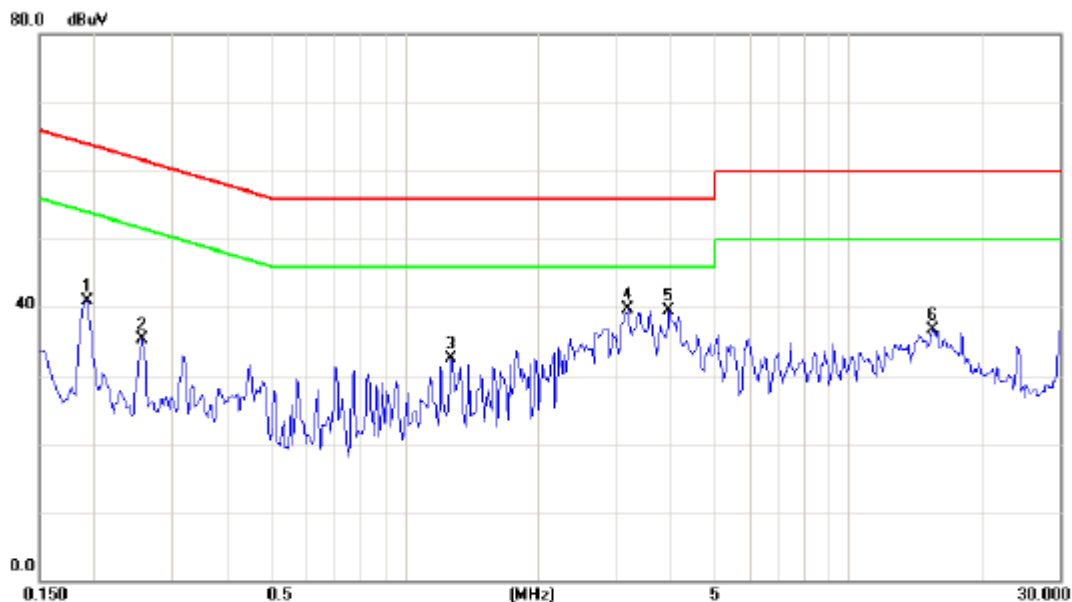

No.	Mk.	Freq. MHz	Reading Level dBuV	Correct Factor dB	Measure- ment dBuV	Limit dBuV	Over dB	Detector	Comment
1		0.1930	31.30	9.69	40.99	63.91	-22.92	peak	
2		0.2555	25.68	9.68	35.36	61.58	-26.22	peak	
3		1.2750	22.70	9.74	32.44	56.00	-23.56	peak	
4	*	3.1797	29.97	9.81	39.78	56.00	-16.22	peak	
5		3.9531	29.60	9.82	39.42	56.00	-16.58	peak	
6		15.4766	26.45	10.30	36.75	60.00	-23.25	peak	



EUT:	Bluetooth speakers	Model Name :	BTK-502
Temperature:	24 °C	Relative Humidity:	60 %
Test Power:	AC 120V/60Hz	Phase:	Line
Test Mode:	LINE IN		

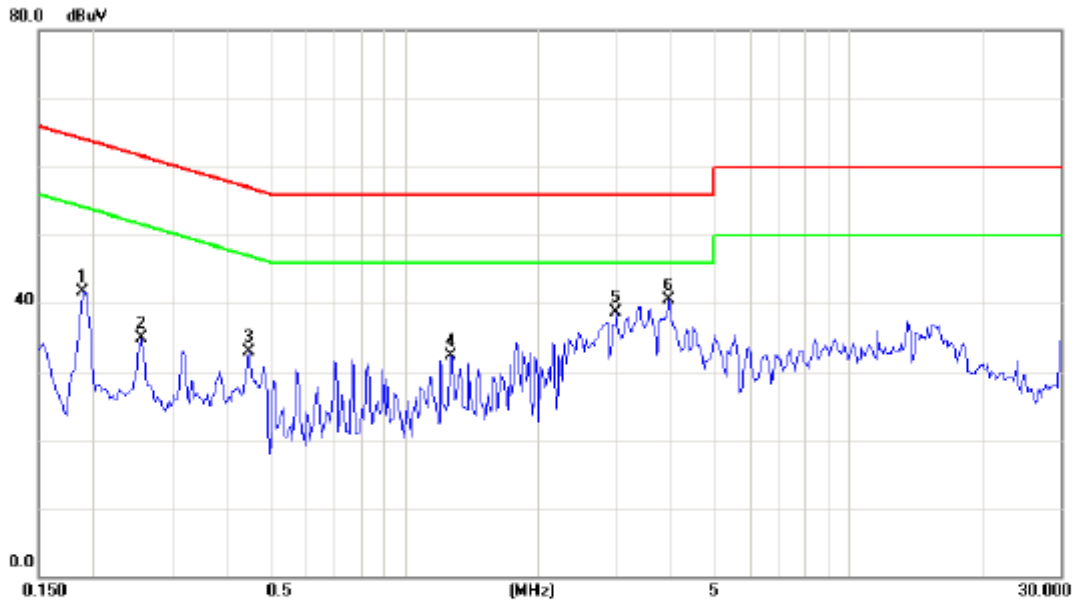

No.	Mk.	Freq. MHz	Reading Level dBuV	Correct Factor dB	Measure- ment dBuV	Limit dBuV	Over dB	Detector	Comment
1		0.1891	32.10	9.68	41.78	64.08	-22.30	peak	
2		0.2555	25.14	9.68	34.82	61.58	-26.76	peak	
3		0.4470	23.16	9.71	32.87	56.93	-24.06	peak	
4		1.2750	22.54	9.73	32.27	56.00	-23.73	peak	
5		2.9937	28.93	9.78	38.71	56.00	-17.29	peak	
6	*	3.9531	30.64	9.82	40.46	56.00	-15.54	peak	



EUT:	Bluetooth speakers	Model Name :	BTK-502
Temperature:	24 °C	Relative Humidity:	60 %
Test Power:	AC 120V/60Hz	Phase:	Neutral
Test Mode:	LINE IN		

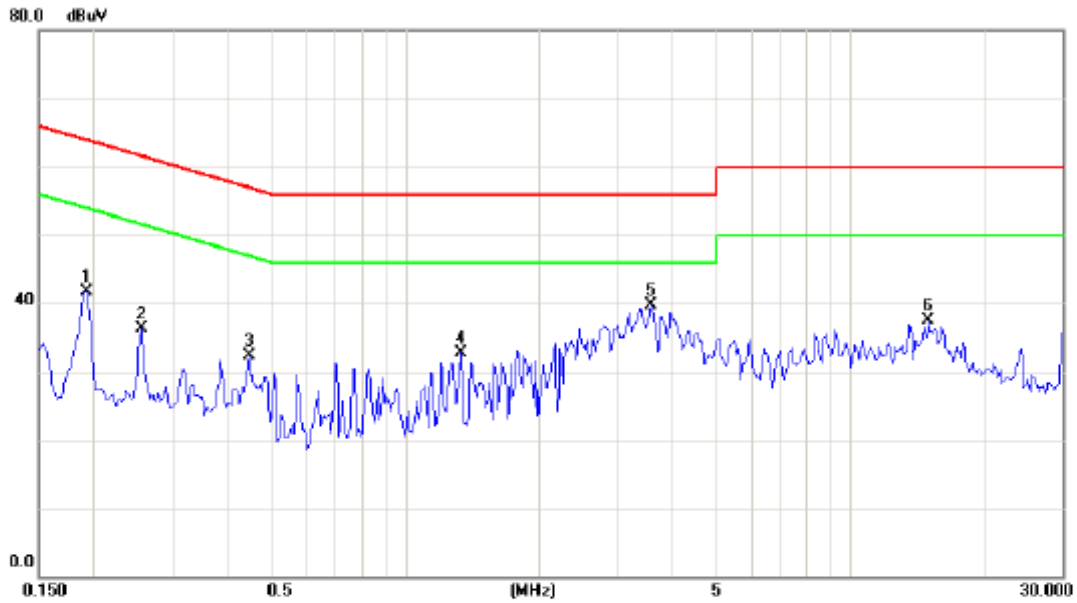

No.	Mk.	Freq. MHz	Reading Level dBuV	Correct Factor dB	Measure- ment dBuV	Limit dBuV	Over dB	Detector	Comment
1		0.1930	32.04	9.69	41.73	63.91	-22.18	peak	
2		0.2555	26.54	9.68	36.22	61.58	-25.36	peak	
3		0.4470	22.66	9.70	32.36	56.93	-24.57	peak	
4		1.3375	22.99	9.74	32.73	56.00	-23.27	peak	
5	*	3.5664	29.97	9.81	39.78	56.00	-16.22	peak	
6		15.0430	27.19	10.28	37.47	60.00	-22.53	peak	



**4.2 RADIATED EMISSION MEASUREMENT**

**4.2.1 RADIATED EMISSION LIMITS (Frequency Range 9KHz-1000MHz)**

20dBc in any 100 kHz bandwidth outside the operating frequency band. In case the emission fall within the restricted band specified on 15.205(a), then the 15.209(a) limit in the table below has to be followed.

Frequencies (MHz)	Field Strength (micorvolts/meter)	Measurement Distance (meters)
0.009~0.490	2400/F(KHz)	300
0.490~1.705	24000/F(KHz)	30
1.705~30.0	30	30
30~88	100	3
88~216	150	3
216~960	200	3
960~1000	500	3

**LIMITS OF RADIATED EMISSION MEASUREMENT (Above 1000MHz)**

FREQUENCY (MHz)	(dBuV/m) (at 3m)	
	PEAK	AVERAGE
Above 1000	74	54

Notes:

- (1) The limit for radiated test was performed according to FCC PART 15C.
- (2) The tighter limit applies at the band edges.
- (3) Emission level (dBuV/m)=20log Emission level (uV/m).

**FREQUENCY RANGE OF RADIATED MEASUREMENT (For unintentional radiators)**

Highest frequency generated or Upper frequency of measurement used in the device or on which the device operates or tunes (MHz)	Range (MHz)
Below 1.705	30
1.705 – 108	1000
108 – 500	2000
500 – 1000	5000
Above 1000	5 <sup>th</sup> harmonic of the highest frequency or 40 GHz, whichever is lower



**4.2.2 MEASUREMENT INSTRUMENTS LIST AND SETTING**

Item	Kind of Equipment	Manufacturer	Type No.	Serial No.	Calibrated Until
1	Antenna	Schwarbeck	VULB9160	9160-3232	May.25.2013
2	Amplifier	HP	8447D	2944A09673	May.04.2013
3	Test Receiver	R&S	ESCI	100382	May.04.2013
4	Test Cable	N/A	C-01_CB03	N/A	Jun.30.2013
5	Antenna	ETS	3115	00075789	May.25.2013
6	Amplifier	Agilent	8449B	3008A02274	May.04.2013
7	Spectrum	Agilent	E4408B	US39240143	Nov.16.2013
8	Test Cable	HUBER+SUHNER	C-45	N/A	May.02.2013
9	Controller	CT	SC100	N/A	N/A
10	Horn Antenna	EMCO	3115	9605-4803	May.25.2013
11	Active Loop Antenna	R&S	HFH2-Z2	830749/020	May.04.2013
12	Broad-Band Horn Antenna	Schwarzbeck	BBHA 9170	9170319	Oct.12.2013

Remark: "N/A" denotes no model name, serial no. or calibration specified.

All calibration period of Equipment List is One Year.

Spectrum Parameter	Setting
Attenuation	Auto
Start Frequency	1000 MHz
Stop Frequency	10th carrier harmonic
RB / VB (Emission in restricted band)	1MHz / 1MHz for Peak, 1 MHz / 10Hz for Average

Receiver Parameter	Setting
Attenuation	Auto
Start ~ Stop Frequency	9kHz~90kHz for PK/AVG detector
Start ~ Stop Frequency	90kHz~110kHz for QP detector
Start ~ Stop Frequency	110kHz~490kHz for PK/AVG detector
Start ~ Stop Frequency	490kHz~30MHz for QP detector
Start ~ Stop Frequency	30MHz~1000MHz for QP detector



#### **4.2.3 TEST PROCEDURE**

- a. The EUT was placed on the top of a rotating table 0.8 meters above the ground at a 3 meter semi-anechoic chamber. The table was rotated 360 degrees to determine the position of the highest radiation.(below 1GHz)
- b. The EUT was placed on the top of a rotating table 0.8 meters above the ground at a 3 meter fully-anechoic chamber. The table was rotated 360 degrees to determine the position of the highest radiation.(above 1GHz)
- c. The height of the equipment or of the substitution antenna shall be 0.8 m; the height of the test antenna shall vary between 1 m to 4 m. Both horizontal and vertical polarizations of the antenna are set to make the measurement.
- d. The initial step in collecting conducted emission data is a spectrum analyzer peak detector mode pre-scanning the measurement frequency range. Significant peaks are then marked and then Quasi Peak detector mode re-measured.
- e. If the Peak Mode measured value compliance with and lower than Quasi Peak Mode Limit, the EUT shall be deemed to meet QP Limits and then no additional QP Mode measurement performed.
- f. For the actual test configuration, please refer to the related Item –EUT Test Photos.

#### **4.2.4 DEVIATION FROM TEST STANDARD**

No deviation

**4.2.5 TEST SETUP**

(A) Radiated Emission Test Set-Up Frequency Below 1 GHz

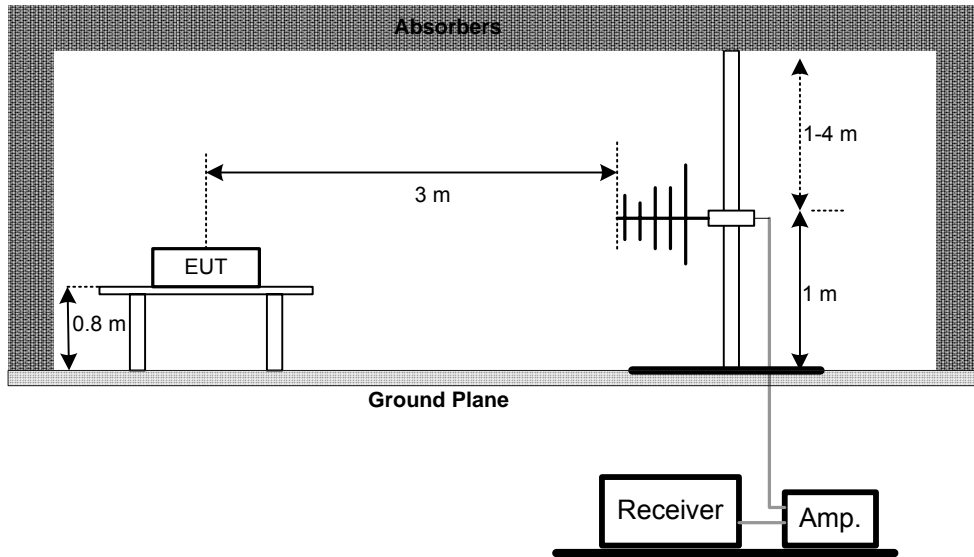

(B) Radiated Emission Test Set-Up Frequency Above 1 GHz

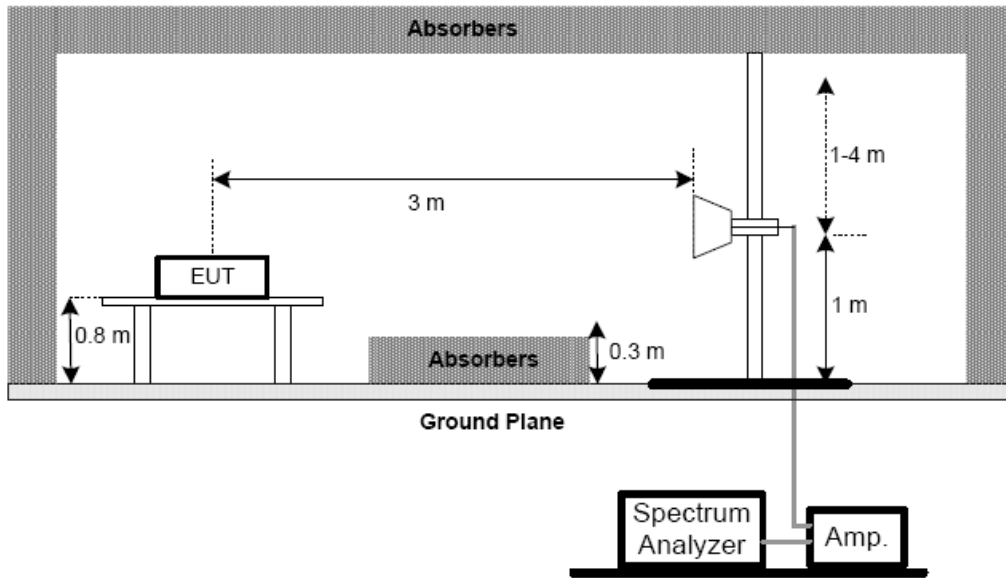



(C) For radiated emissions below 30MHz

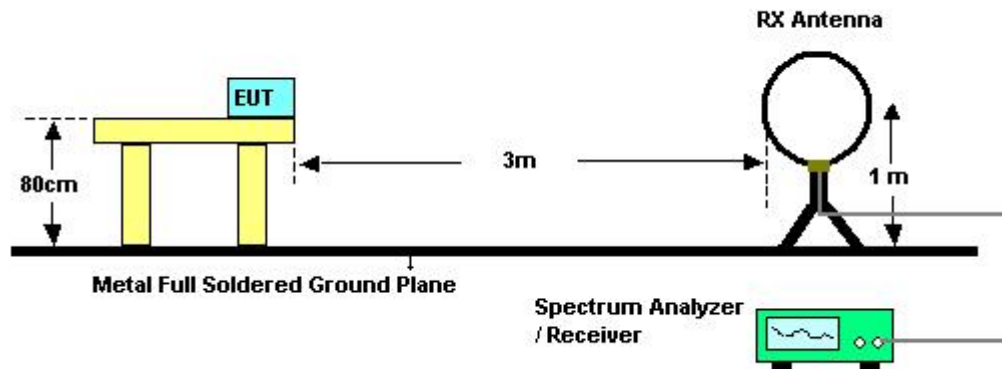

#### 4.2.6 EUT OPERATING CONDITIONS

The EUT tested system was configured as the statements of 4.1.6 Unless otherwise a special operating condition is specified in the follows during the testing.



**4.2.7 TEST RESULTS (BELOW 30MHZ)**

EUT :	Bluetooth speakers	Model Name :	BTK-502
Temperature :	24° C	Relative Humidity :	56 %
Test Voltage :	DC 3.7V		
Test Mode :	TX 2402MHz –CH00-1Mbps		

Freq. (MHz)	Ant. 0°/90°	Reading(RA) (dBuV)	Corr.Factor(CF) (dB)	Measured(FS) (dBuV/m)	Limits(QP) (dBuV/m)	Margin (dB)	Note
0.0614	0°	20.14	22.17	42.31	111.84	-69.53	AVG
0.0614	0°	34.89	23.76	58.65	131.84	-73.19	PK
0.3573	0°	18.97	20.14	39.11	96.54	-57.43	AVG
0.3573	0°	35.67	21.90	57.57	116.54	-58.98	PK
0.4586	0°	22.51	19.90	42.41	94.38	-51.97	AVG
0.4586	0°	33.27	20.14	53.41	114.38	-60.96	PK
1.5728	0°	28.71	19.54	48.25	63.67	-15.42	QP
2.6422	0°	27.58	19.11	46.69	69.54	-22.85	QP
3.3547	0°	30.65	18.94	49.59	69.54	-19.95	QP

Freq. (MHz)	Ant. 0°/90°	Reading(RA) (dBuV)	Corr.Factor(CF) (dB)	Measured(FS) (dBuV/m)	Limits(QP) (dBuV/m)	Margin (dB)	Note
0.0687	90°	17.76	22.03	39.79	110.87	-71.08	AVG
0.0687	90°	26.59	22.25	48.84	130.87	-82.03	PK
0.2794	90°	20.46	20.33	40.79	98.68	-57.89	AVG
0.2794	90°	33.66	21.19	54.85	118.68	-63.83	PK
1.7537	90°	27.88	19.52	47.40	69.54	-22.14	QP
3.8445	90°	29.46	18.98	48.44	69.54	-21.10	QP
5.8219	90°	26.58	18.13	44.71	69.54	-24.83	QP
7.1520	90°	25.61	18.03	43.64	69.54	-25.90	QP

**Remark :**

- (1) The amplitude of spurious emissions which are attenuated by more than 20 dB below the permissible value has no need to be reported ◦
- (2) Distance extrapolation factor = 40 log (specific distance / test distance) (dB); ◦
- (3) Limit line = specific limits (dBuV) + distance extrapolation factor. ◦



#### **4.2.8 TEST RESULTS-BETWEEN 30MHZ AND 1000MHZ**

Remark :

- (1) Reading in which marked as QP or Peak means measurements by using are Quasi-Peak Mode or Peak Mode with Detector BW=120KHz ; SPA setting in RBW=120KHz, VBW =120KHz, Swp. Time = 0.3 sec./MHz.
- (2) All readings are Peak unless otherwise stated QP in column of 『 Note 』 . Peak denotes that the Peak reading compliance with the QP Limits and then QP Mode measurement didn't perform.
- (3) Measuring frequency range from 30MHz to 1000MHz.
- (4) If the peak scan value lower limit more than 20dB, then this signal data does not show in table.



# Neutron Engineering Inc.

EUT:	Bluetooth speakers	Model Name:	BTK-502
Temperature:	24 °C	Relative Humidity:	56 %
Test Power:	DC 3.7V	Phase:	Vertical
Test Mode:	TX 2402MHz –CH00-1Mbps		

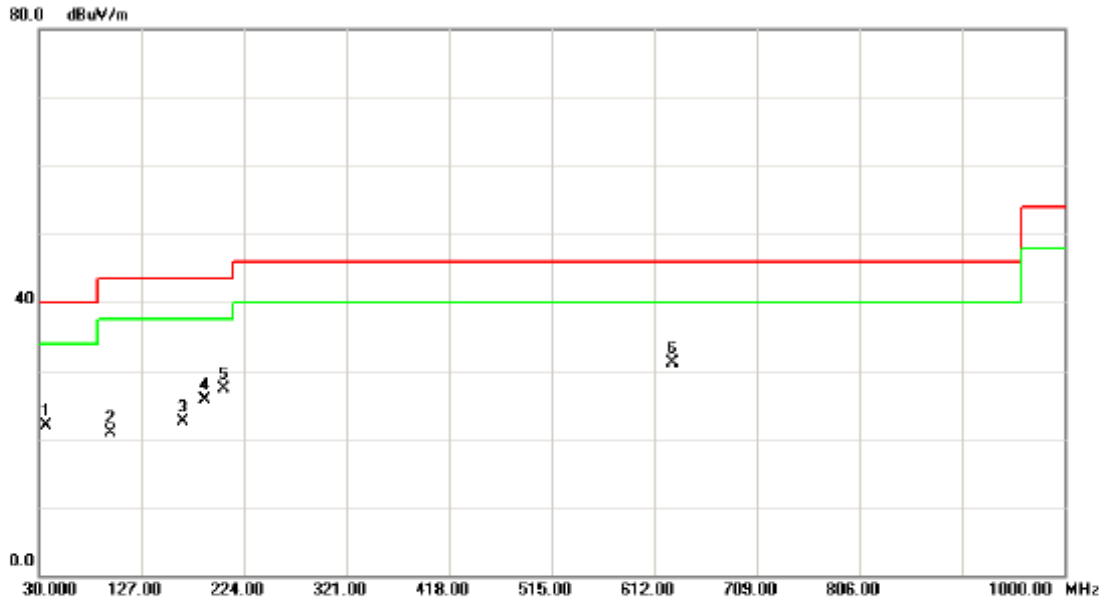

No.	Mk.	Freq. MHz	Reading Level dBuV	Correct Factor dB	Measure- ment dBuV/m	Limit dBuV/m	Over dB	Detector	Comment
1		37.2750	38.94	-17.05	21.89	40.00	-18.11	peak	
2		97.9000	39.62	-18.68	20.94	43.50	-22.56	peak	
3		165.8000	40.33	-17.77	22.56	43.50	-20.94	peak	
4		187.6250	42.82	-17.13	25.69	43.50	-17.81	peak	
5		204.6000	44.21	-16.85	27.36	43.50	-16.14	peak	
6	*	628.9750	36.02	-5.01	31.01	46.00	-14.99	peak	



EUT:	Bluetooth speakers	Model Name:	BTK-502
Temperature:	24 °C	Relative Humidity:	56 %
Test Power:	DC 3.7V	Phase:	Horizontal
Test Mode:	TX 2402MHz –CH00-1Mbps		

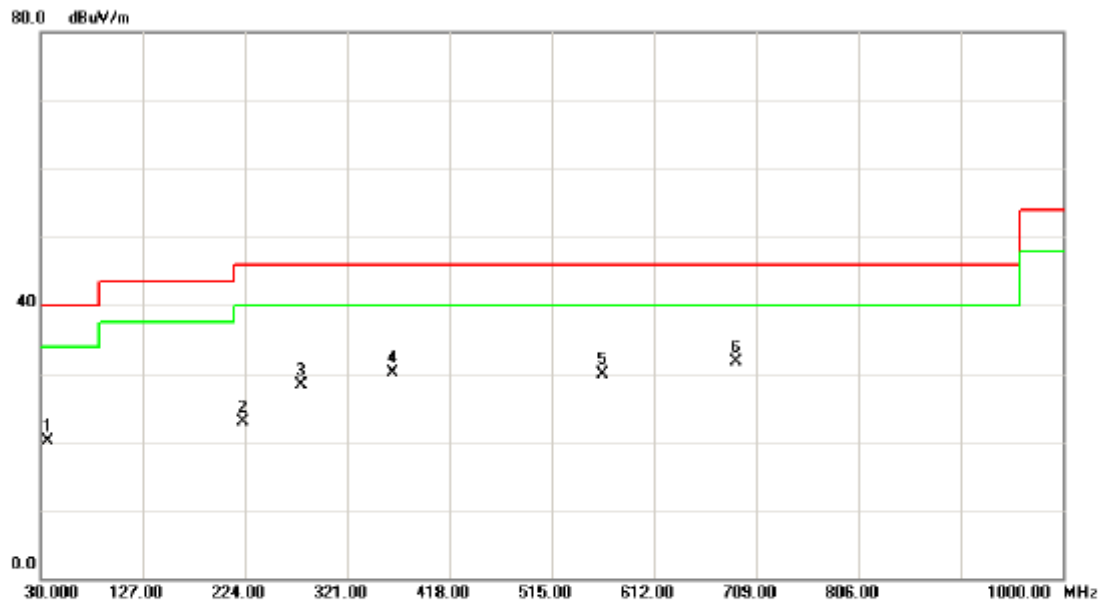

No.	Mk.	Freq. MHz	Reading Level dBuV	Correct Factor dB	Measure- ment dBuV/m	Limit dBuV/m	Over dB	Detector	Comment
1		37.2750	37.20	-17.05	20.15	40.00	-19.85	peak	
2		221.5750	39.18	-16.28	22.90	46.00	-23.10	peak	
3		277.3500	41.73	-13.34	28.39	46.00	-17.61	peak	
4		364.6500	41.19	-11.02	30.17	46.00	-15.83	peak	
5		563.5000	36.28	-6.30	29.98	46.00	-16.02	peak	
6	*	689.6000	36.38	-4.65	31.73	46.00	-14.27	peak	



# Neutron Engineering Inc.

EUT:	Bluetooth speakers	Model Name:	BTK-502
Temperature:	24 °C	Relative Humidity:	56 %
Test Power:	DC 3.7V	Phase:	Vertical
Test Mode:	TX 2440MHz –CH19-1Mbps		

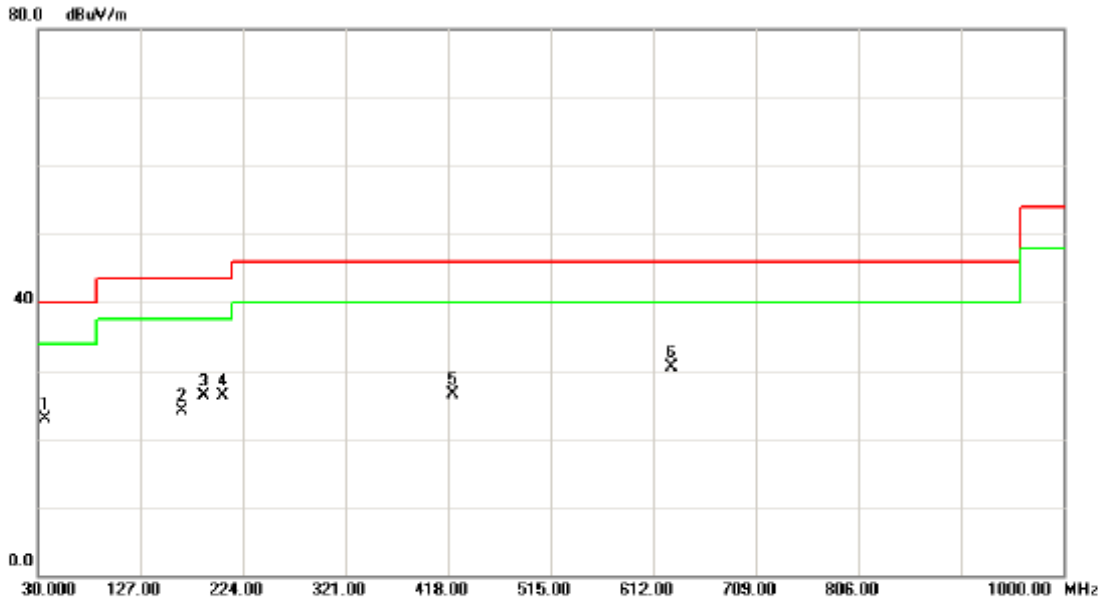

No.	Mk.	Freq. MHz	Reading Level dBuV	Correct Factor dB	Measure- ment dBuV/m	Limit dBuV/m	Over dB	Detector	Comment
1		37.2750	39.97	-17.05	22.92	40.00	-17.08	peak	
2		165.8000	41.86	-17.77	24.09	43.50	-19.41	peak	
3		187.6250	43.35	-17.13	26.22	43.50	-17.28	peak	
4		204.6000	43.24	-16.85	26.39	43.50	-17.11	peak	
5		422.8500	35.96	-9.44	26.52	46.00	-19.48	peak	
6	*	628.9750	35.55	-5.01	30.54	46.00	-15.46	peak	



EUT:	Bluetooth speakers	Model Name:	BTK-502
Temperature:	24 °C	Relative Humidity:	56 %
Test Power:	DC 3.7V	Phase:	Horizontal
Test Mode:	TX 2440MHz –CH19-1Mbps		

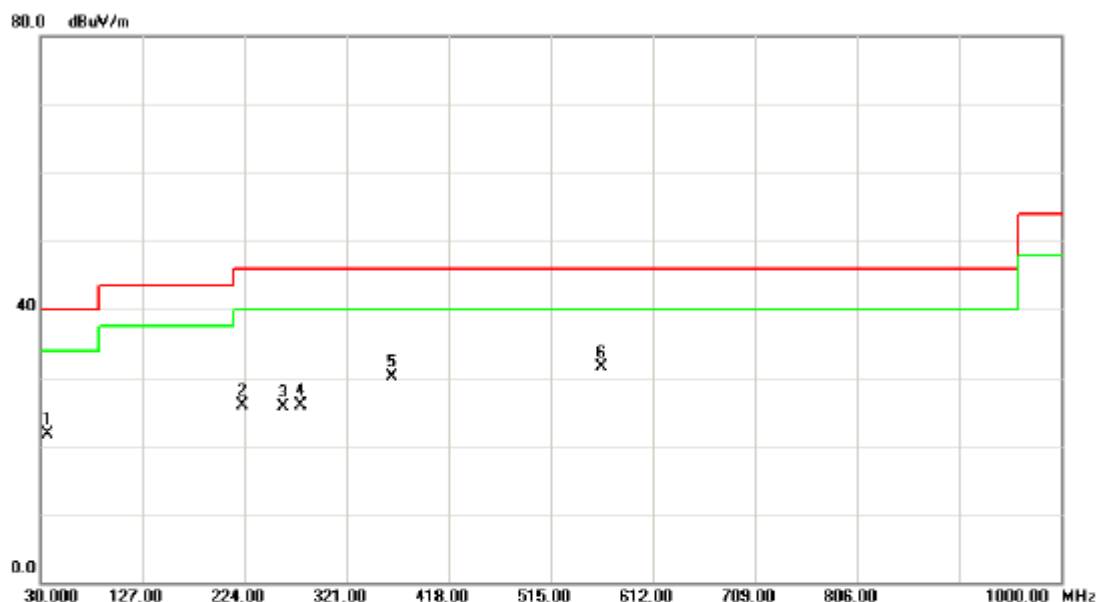

No.	Mk.	Freq. MHz	Reading Level dBuV	Correct Factor dB	Measure- ment dBuV/m	Limit dBuV/m	Over dB	Detector	Comment
1		37.2750	38.68	-17.05	21.63	40.00	-18.37	peak	
2		221.5750	42.16	-16.28	25.88	46.00	-20.12	peak	
3		260.3750	40.07	-14.36	25.71	46.00	-20.29	peak	
4		277.3500	39.21	-13.34	25.87	46.00	-20.13	peak	
5		364.6500	41.17	-11.02	30.15	46.00	-15.85	peak	
6	*	563.5000	37.76	-6.30	31.46	46.00	-14.54	peak	



EUT:	Bluetooth speakers	Model Name:	BTK-502
Temperature:	24 °C	Relative Humidity:	56 %
Test Power:	DC 3.7V	Phase:	Vertical
Test Mode:	TX 2480MHz –CH39-1Mbps		

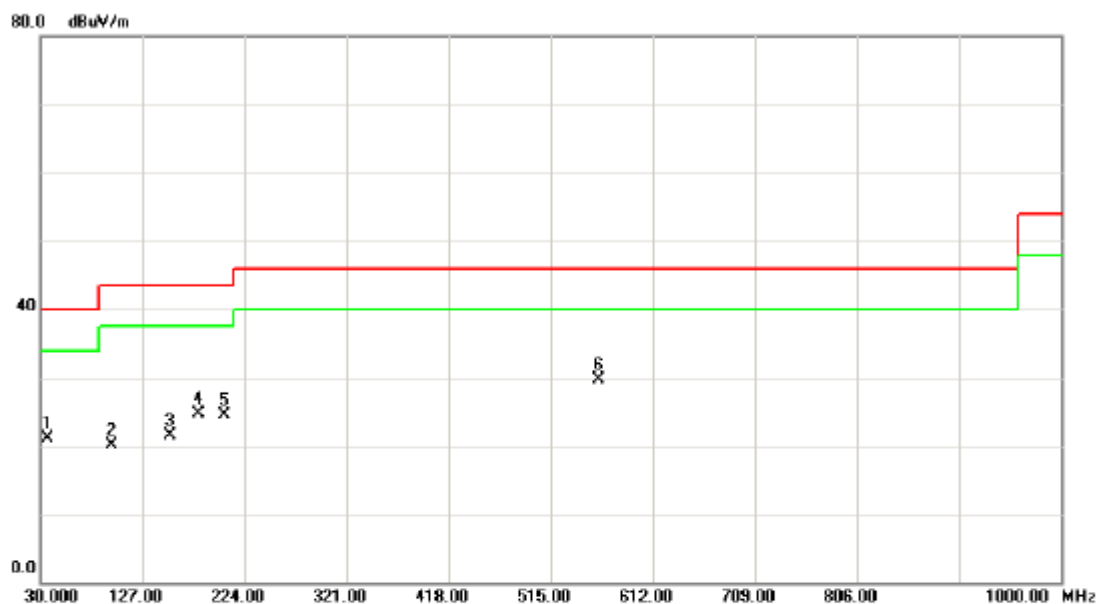

No. Mk.	Freq. MHz	Reading Level dBuV	Correct Factor dB	Measurement dBuV/m	Limit dBuV/m	Over dB	Detector	Comment
1	37.2750	38.13	-17.05	21.08	40.00	-18.92	peak	
2	97.9000	38.81	-18.68	20.13	43.50	-23.37	peak	
3	153.6750	39.37	-17.88	21.49	43.50	-22.01	peak	
4	180.3500	42.04	-17.25	24.79	43.50	-18.71	peak	
5	204.6000	41.40	-16.85	24.55	43.50	-18.95	peak	
6 *	561.0750	36.02	-6.36	29.66	46.00	-16.34	peak	





EUT:	Bluetooth speakers	Model Name:	BTK-502
Temperature:	24 °C	Relative Humidity:	56 %
Test Power:	DC 3.7V	Phase:	Horizontal
Test Mode:	TX 2480MHz –CH39-1Mbps		



No.	Mk.	Freq. MHz	Reading Level dBuV	Correct Factor dB	Measure- ment dBuV/m	Limit dBuV/m	Over dB	Detector	Comment
1		221.5750	40.56	-16.28	24.28	46.00	-21.72	peak	
2		277.3500	41.11	-13.34	27.77	46.00	-18.23	peak	
3		364.6500	40.57	-11.02	29.55	46.00	-16.45	peak	
4		481.0500	36.29	-8.63	27.66	46.00	-18.34	peak	
5		631.4000	35.81	-4.97	30.84	46.00	-15.16	peak	
6	*	689.6000	36.26	-4.65	31.61	46.00	-14.39	peak	



**4.2.8 TEST RESULTS (ABOVE 1000 MHZ)**

EUT :	Bluetooth speakers	Model Name :	BTK-502
Temperature :	23 °C	Relative Humidity :	51 %
Pressure :	1010 hPa	Test Voltage :	DC 3.7V
Test Mode :	TX 2402MHz – CH 00-1Mbps		

Freq. (MHz)	Ant.Pol. H/V	Reading		Ant./CF CF(dB)	Act.		Limit		Note
		Peak (dBuV)	AV (dBuV)		Peak (dBuV/m)	AV (dBuV/m)	Peak (dBuV/m)	AV (dBuV/m)	
2390.00	V	21.86	10.56	32.28	54.14	42.84	74.00	54.00	X/E
<b>2402.05</b>	<b>V</b>	<b>63.45</b>	<b>27.76</b>	<b>32.27</b>	<b>95.72</b>	<b>60.03</b>			<b>X/E</b>
4804.12	V	49.58	33.24	6.11	55.69	39.35	74.00	54.00	X/H

Remark :

- (1) All readings are Peak unless otherwise stated QP in column of 『Note』 . Peak denotes that the Peak reading compliance with the QP Limits and then QP Mode measurement didn't perform .
- (2) Measuring frequency range from 30MHz to 1000MHz or the 10th harmonic of highest fundamental frequency .“F” denotes fundamental frequency; “H” denotes spurious frequency. “E” denotes band edge frequency. (This judgment method includes the Band Edge Requirement.)
- (3) Radiated emissions measured in frequency range above 1000MHz were made with an instrument using Peak detector mode and AV detector mode of the emission .
- (4) Data of measurement within this frequency range shown “ \* ” in the table above means the reading of emissions are attenuated more than 20dB below the permissible limits or the field strength is too small to be measured.
- (5) A preamp and high pass filter were used for this test in order to provide sufficient measurement sensitivity.
- (6) EUT Orthogonal Axis :  
“X” - denotes Laid on Table ; “Y” - denotes Vertical Stand ; “Z” - denotes Side Stand
- (7) During the measurements above 1 GHz it is taken care of that the EUT is always within the 3 dB cone of radiation BW of the used antenna



TX CH00 (Above 1000 MHz, Vertical)

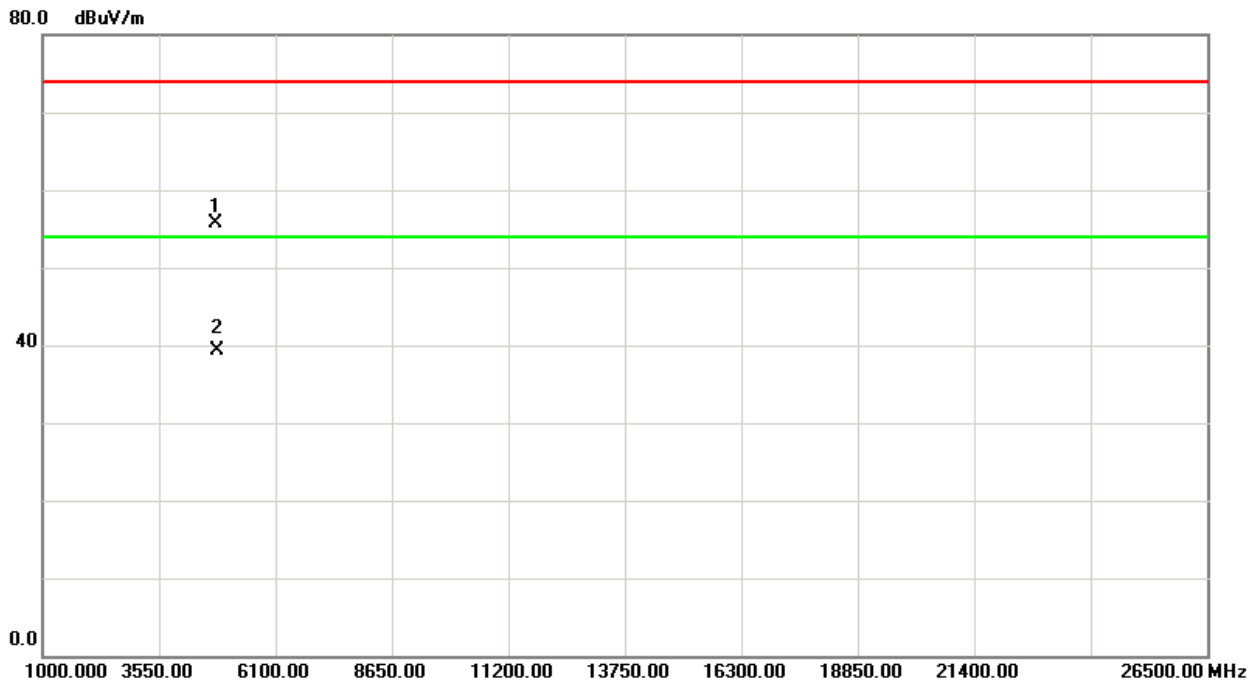
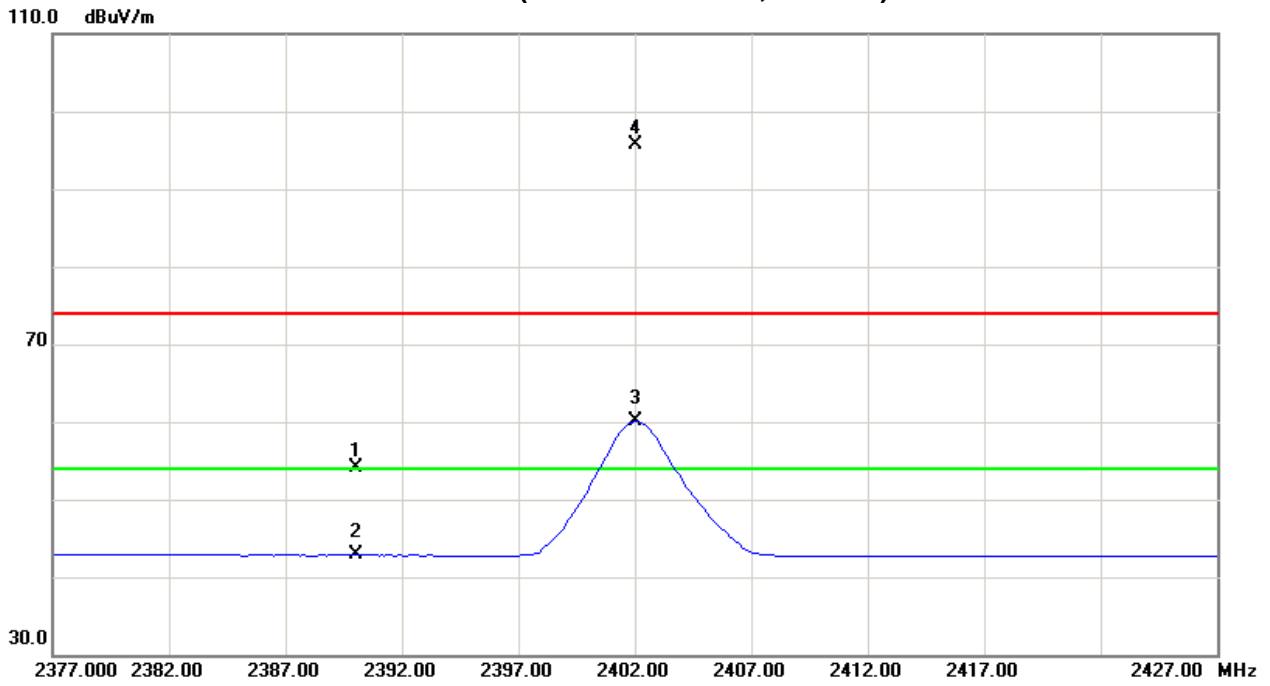



## Neutron Engineering Inc.

EUT :	Bluetooth speakers	Model Name :	BTK-502
Temperature :	23 °C	Relative Humidity :	51 %
Pressure :	1010 hPa	Test Voltage :	DC 3.7V
Test Mode :	TX 2402MHz – CH 00-1Mbps		

Freq.	Ant.Pol.	Reading		Ant./CF	Act.		Limit		Note
		Peak	AV		Peak	AV	Peak	AV	
(MHz)	H/V	(dBuV)	(dBuV)	CF(dB)	(dBuV/m)	(dBuV/m)	(dBuV/m)	(dBuV/m)	
2390.00	H	22.47	10.54	32.28	54.75	42.82	74.00	54.00	X/E
<b>2402.15</b>	<b>H</b>	<b>64.96</b>	<b>28.82</b>	<b>32.27</b>	<b>97.23</b>	<b>61.09</b>			<b>X/F</b>
4804.05	H	46.92	31.86	6.11	53.03	37.97	74.00	54.00	X/H

### Remark :

- (1) All readings are Peak unless otherwise stated QP in column of 『 Note 』 . Peak denotes that the Peak reading compliance with the QP Limits and then QP Mode measurement didn't perform .
- (2) Measuring frequency range from 30MHz to 1000MHz or the 10th harmonic of highest fundamental frequency . "F" denotes fundamental frequency; "H" denotes spurious frequency. "E" denotes band edge frequency. (This judgment method includes the Band Edge Requirement.)
- (3) Radiated emissions measured in frequency range above 1000MHz were made with an instrument using Peak detector mode and AV detector mode of the emission .
- (4) Data of measurement within this frequency range shown " \* " in the table above means the reading of emissions are attenuated more than 20dB below the permissible limits or the field strength is too small to be measured.
- (5) A preamp and high pass filter were used for this test in order to provide sufficient measurement sensitivity.
- (6) EUT Orthogonal Axis :  
"X" - denotes Laid on Table ; "Y" - denotes Vertical Stand ; "Z" - denotes Side Stand
- (7) During the measurements above 1 GHz it is taken care of that the EUT is always within the 3 dB cone of radiation BW of the used antenna



TX CH00 (Above 1000 MHz, Horizontal)

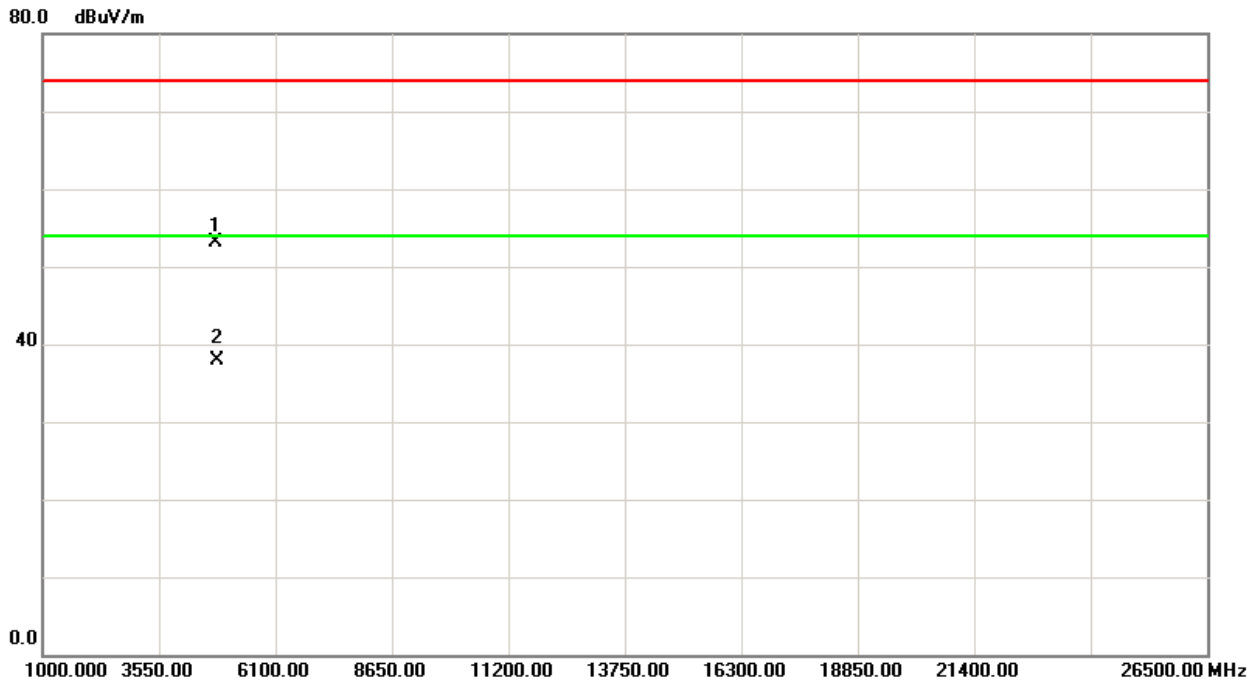
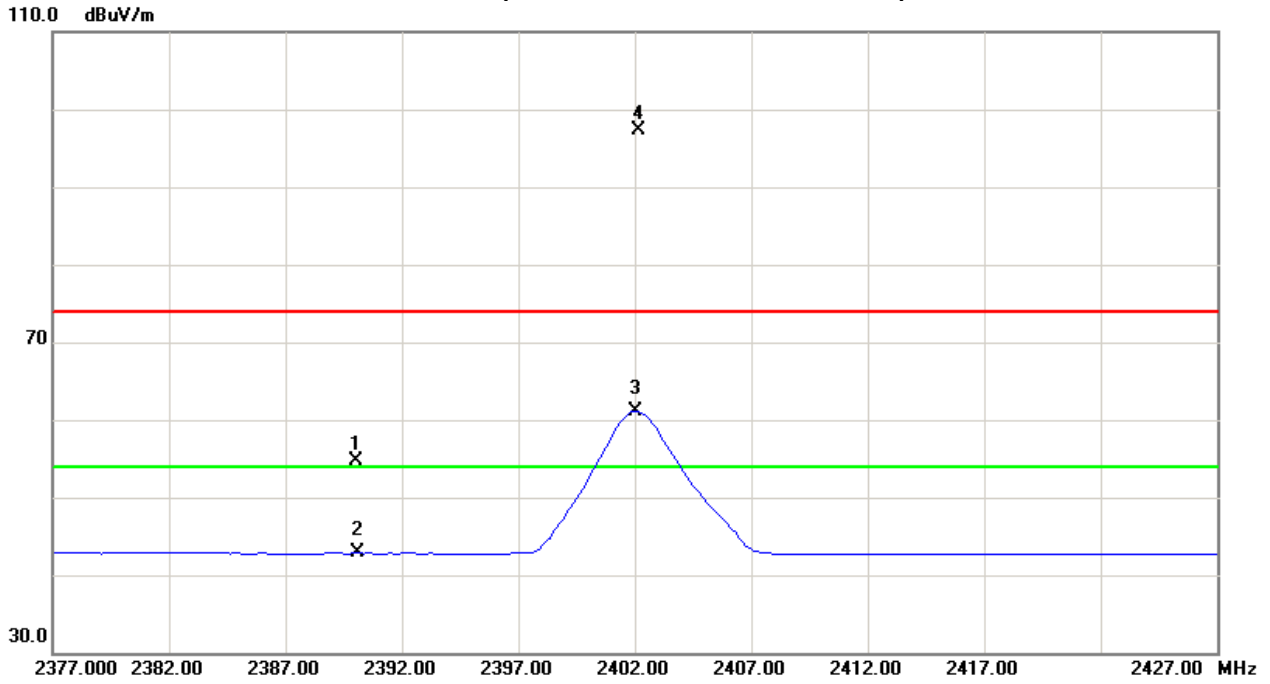



EUT :	Bluetooth speakers	Model Name :	BTK-502
Temperature :	23 °C	Relative Humidity :	51 %
Pressure :	1010 hPa	Test Voltage :	DC 3.7V
Test Mode :	TX 2440MHz –CH19-1Mbps		

Freq.	Ant.Pol.	Reading		Ant./CF	Act.		Limit		Note
		Peak	AV		Peak	AV	Peak	AV	
(MHz)	H/V	(dBuV)	(dBuV)	CF(dB)	(dBuV/m)	(dBuV/m)	(dBuV/m)	(dBuV/m)	
<b>2439.88</b>	<b>V</b>	<b>63.04</b>	<b>27.31</b>	<b>32.22</b>	<b>95.26</b>	<b>59.53</b>			<b>X/F</b>
4880.02	V	50.21	33.69	6.42	56.63	40.11	74.00	54.00	X/H

Remark :

- (1) All readings are Peak unless otherwise stated QP in column of 『Note』 . Peak denotes that the Peak reading compliance with the QP Limits and then QP Mode measurement didn't perform .
- (2) Measuring frequency range from 30MHz to 1000MHz or the 10th harmonic of highest fundamental frequency .“F” denotes fundamental frequency; “H” denotes spurious frequency. “E” denotes band edge frequency. (This judgment method includes the Band Edge Requirement.)
- (3) Radiated emissions measured in frequency range above 1000MHz were made with an instrument using Peak detector mode and AV detector mode of the emission .
- (4) Data of measurement within this frequency range shown “ \* ” in the table above means the reading of emissions are attenuated more than 20dB below the permissible limits or the field strength is too small to be measured.
- (5) A preamp and high pass filter were used for this test in order to provide sufficient measurement sensitivity.
- (6) EUT Orthogonal Axis :  
“X” - denotes Laid on Table ; “Y” - denotes Vertical Stand ; “Z” - denotes Side Stand
- (7) During the measurements above 1 GHz it is taken care of that the EUT is always within the 3 dB cone of radiation BW of the used antenna



TX CH19 (Above 1000 MHz, Vertical)

110.0 dBuV/m

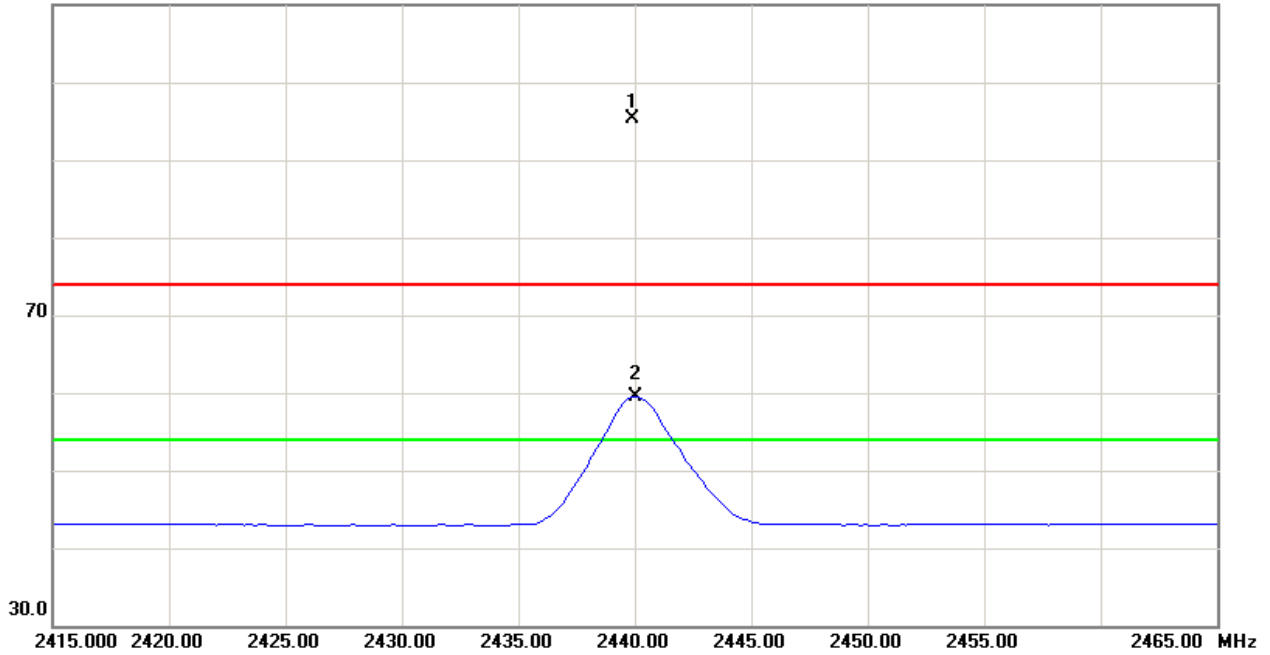

80.0 dBuV/m

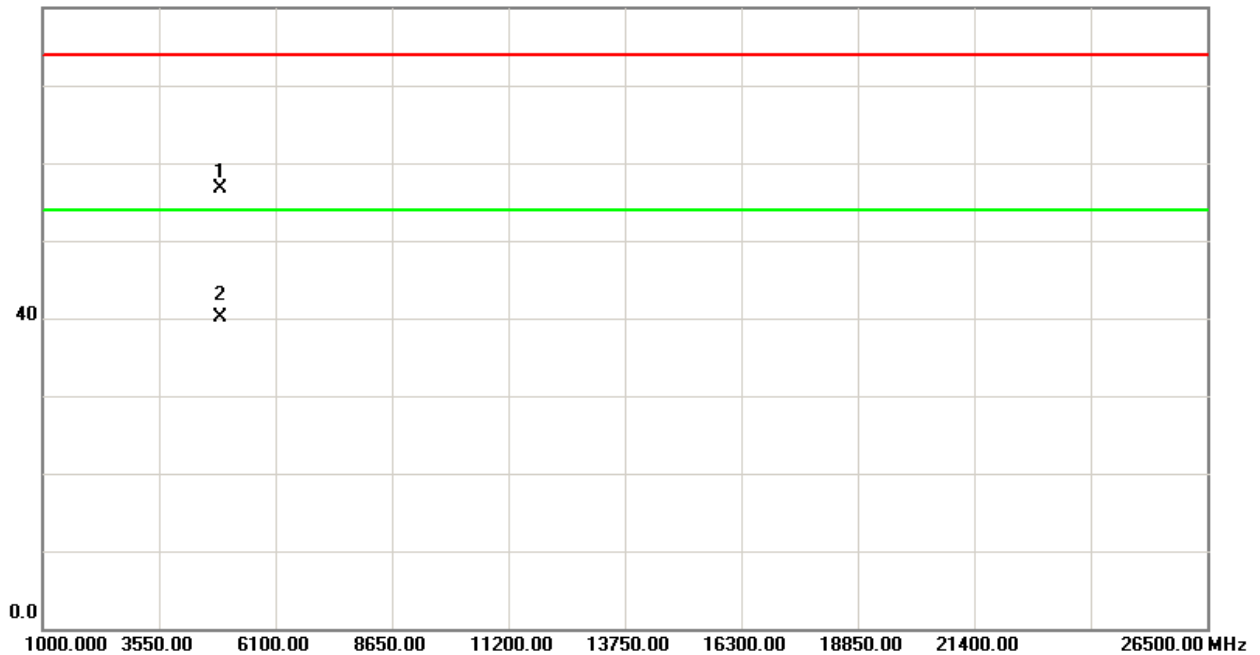



EUT :	Bluetooth speakers	Model Name :	BTK-502
Temperature :	23 °C	Relative Humidity :	51 %
Pressure :	1010 hPa	Test Voltage :	DC 3.7V
Test Mode :	TX 2440MHz –CH19-1Mbps		

Freq. (MHz)	Ant.Pol. H/V	Reading		Ant./CF CF(dB)	Act.		Limit		Note
		Peak (dBuV)	AV (dBuV)		Peak (dBuV/m)	AV (dBuV/m)	Peak (dBuV/m)	AV (dBuV/m)	
<b>2439.88</b>	<b>H</b>	<b>65.06</b>	<b>29.34</b>	<b>32.22</b>	<b>97.28</b>	<b>61.56</b>			<b>X/F</b>
4880.03	H	46.24	32.23	6.42	52.66	38.65	74.00	54.00	X/H

Remark :

- (1) All readings are Peak unless otherwise stated QP in column of 『Note』 . Peak denotes that the Peak reading compliance with the QP Limits and then QP Mode measurement didn't perform .
- (2) Measuring frequency range from 30MHz to 1000MHz or the 10th harmonic of highest fundamental frequency .“F” denotes fundamental frequency; “H” denotes spurious frequency. “E” denotes band edge frequency. (This judgment method includes the Band Edge Requirement.)
- (3) Radiated emissions measured in frequency range above 1000MHz were made with an instrument using Peak detector mode and AV detector mode of the emission .
- (4) Data of measurement within this frequency range shown “ \* ” in the table above means the reading of emissions are attenuated more than 20dB below the permissible limits or the field strength is too small to be measured.
- (5) A preamp and high pass filter were used for this test in order to provide sufficient measurement sensitivity.
- (6) EUT Orthogonal Axis :  
“X” - denotes Laid on Table ; “Y” - denotes Vertical Stand ; “Z” - denotes Side Stand
- (7) During the measurements above 1 GHz it is taken care of that the EUT is always within the 3 dB cone of radiation BW of the used antenna





TX CH19 (Above 1000 MHz, Horizontal)

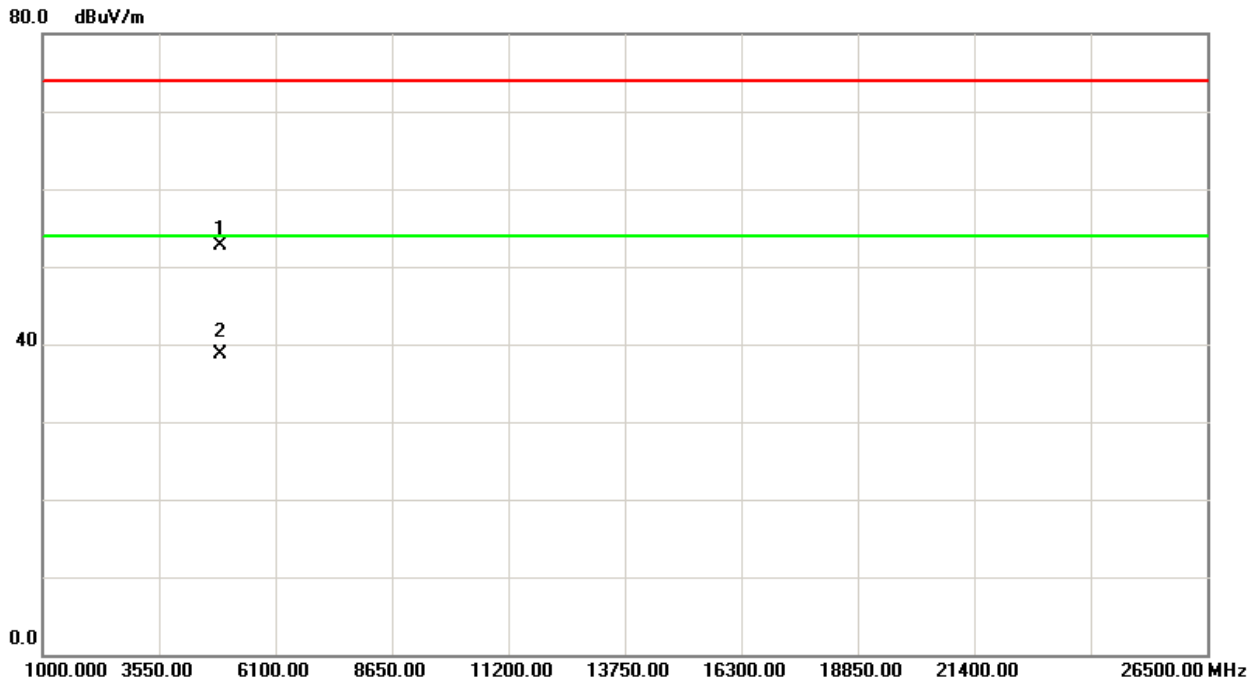
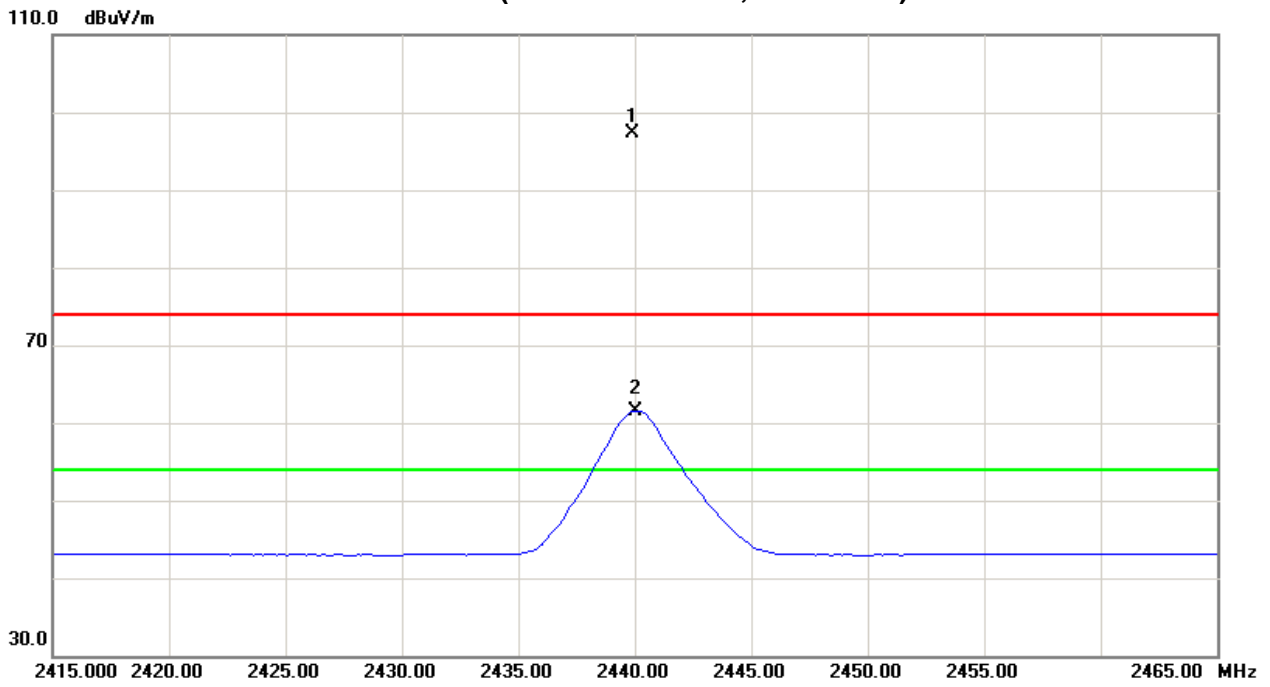



EUT :	Bluetooth speakers	Model Name :	BTK-502
Temperature :	23 °C	Relative Humidity :	51 %
Pressure :	1010 hPa	Test Voltage :	DC 3.7V
Test Mode :	TX 2480MHz –CH39-1Mbps		

Freq. (MHz)	Ant.Pol. H/V	Reading		Ant./CF CF(dB)	Act.		Limit		Note
		Peak (dBuV)	AV (dBuV)		Peak (dBuV/m)	AV (dBuV/m)	Peak (dBuV/m)	AV (dBuV/m)	
<b>2479.85</b>	<b>V</b>	<b>63.92</b>	<b>27.46</b>	<b>32.18</b>	<b>96.10</b>	<b>59.64</b>			<b>X/F</b>
2483.50	V	27.55	14.29	32.17	59.72	46.46	74.00	54.00	X/E
4960.04	V	49.33	32.25	6.74	56.07	38.99	74.00	54.00	X/H

Remark :

- (1) All readings are Peak unless otherwise stated QP in column of 『 Note 』 . Peak denotes that the Peak reading compliance with the QP Limits and then QP Mode measurement didn't perform .
- (2) Measuring frequency range from 30MHz to 1000MHz or the 10th harmonic of highest fundamental frequency .“F” denotes fundamental frequency; “H” denotes spurious frequency. “E” denotes band edge frequency. (This judgment method includes the Band Edge Requirement.)
- (3) Radiated emissions measured in frequency range above 1000MHz were made with an instrument using Peak detector mode and AV detector mode of the emission .
- (4) Data of measurement within this frequency range shown “ \* ” in the table above means the reading of emissions are attenuated more than 20dB below the permissible limits or the field strength is too small to be measured.
- (5) A preamp and high pass filter were used for this test in order to provide sufficient measurement sensitivity.
- (6) EUT Orthogonal Axis :  
“X” - denotes Laid on Table ; “Y” - denotes Vertical Stand ; “Z” - denotes Side Stand
- (7) During the measurements above 1 GHz it is taken care of that the EUT is always within the 3 dB cone of radiation BW of the used antenna



TX CH39 (Above 1000 MHz, Vertical)

110.0 dBuV/m

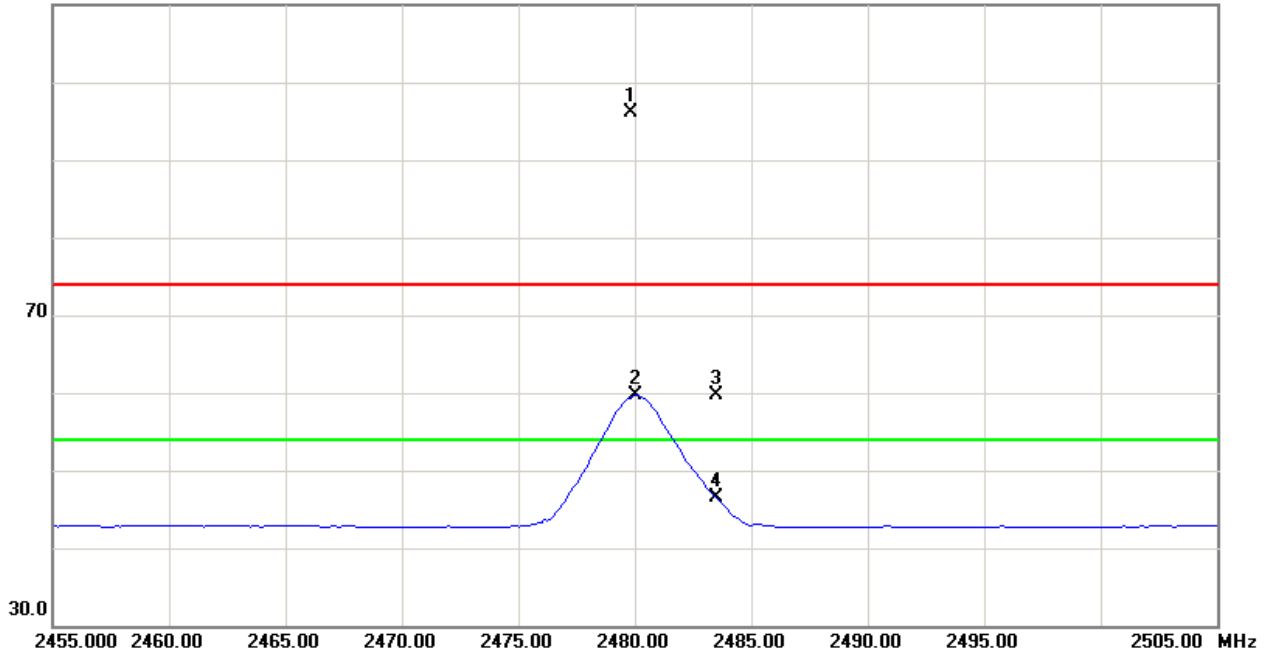

80.0 dBuV/m

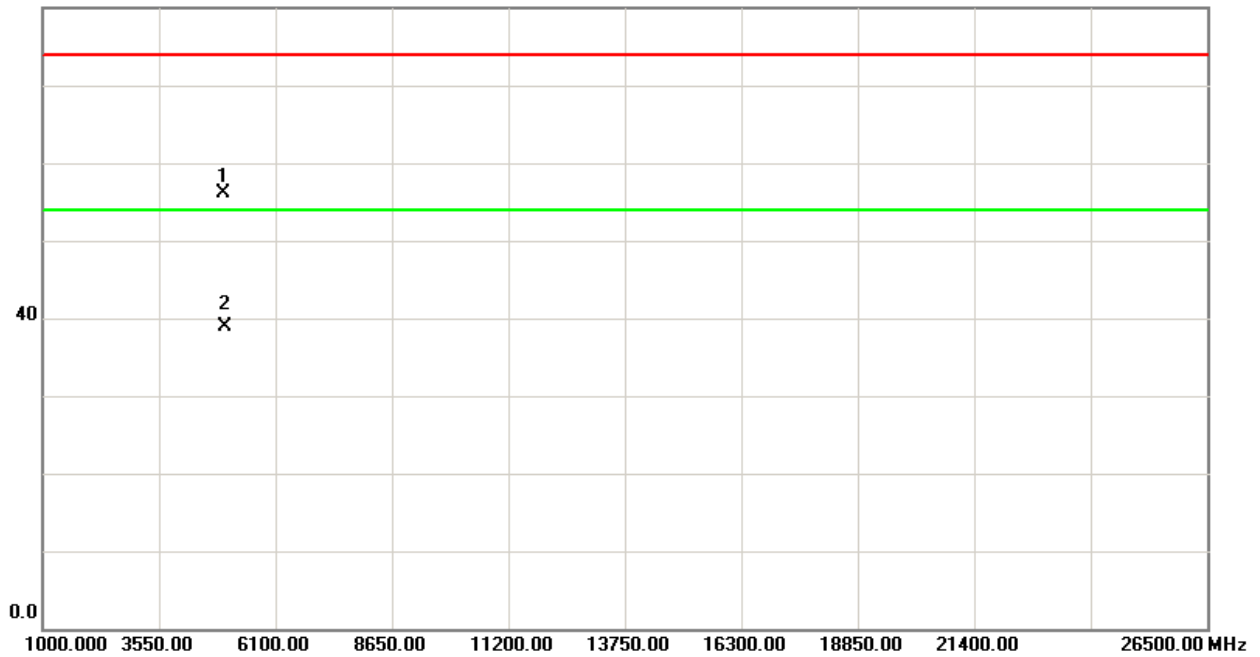



EUT :	Bluetooth speakers	Model Name :	BTK-502
Temperature :	23 °C	Relative Humidity :	51 %
Pressure :	1010 hPa	Test Voltage :	DC 3.7V
Test Mode :	TX 2480MHz –CH39-1Mbps		

Freq.	Ant.Pol.	Reading		Ant./CF	Act.		Limit		Note
		Peak	AV		Peak	AV	Peak	AV	
(MHz)	H/V	(dBuV)	(dBuV)	CF(dB)	(dBuV/m)	(dBuV/m)	(dBuV/m)	(dBuV/m)	
<b>2479.95</b>	<b>H</b>	<b>65.87</b>	<b>29.81</b>	<b>32.18</b>	<b>98.05</b>	<b>61.99</b>			<b>X/F</b>
2483.50	H	33.37	16.48	32.17	65.54	48.65	74.00	54.00	X/E
4960.10	H	46.83	31.66	6.74	53.57	38.40	74.00	54.00	X/H

Remark :

- (1) All readings are Peak unless otherwise stated QP in column of 『Note』 . Peak denotes that the Peak reading compliance with the QP Limits and then QP Mode measurement didn't perform .
- (2) Measuring frequency range from 30MHz to 1000MHz or the 10th harmonic of highest fundamental frequency .“F” denotes fundamental frequency; “H” denotes spurious frequency. “E” denotes band edge frequency. (This judgment method includes the Band Edge Requirement.)
- (3) Radiated emissions measured in frequency range above 1000MHz were made with an instrument using Peak detector mode and AV detector mode of the emission .
- (4) Data of measurement within this frequency range shown “ \* ” in the table above means the reading of emissions are attenuated more than 20dB below the permissible limits or the field strength is too small to be measured.
- (5) A preamp and high pass filter were used for this test in order to provide sufficient measurement sensitivity.
- (6) EUT Orthogonal Axis :  
 “X” - denotes Laid on Table ; “Y” - denotes Vertical Stand ; “Z” - denotes Side Stand
- (7) During the measurements above 1 GHz it is taken care of that the EUT is always within the 3 dB cone of radiation BW of the used antenna



TX CH39 (Above 1000 MHz, Horizontal)

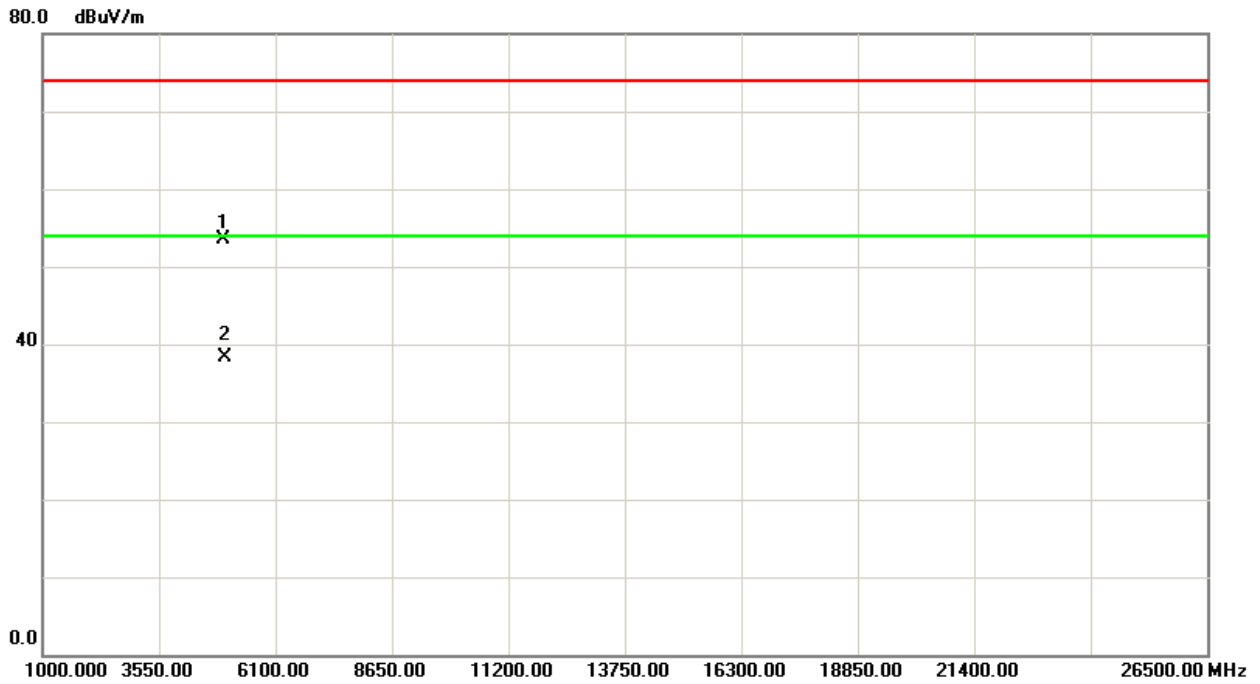
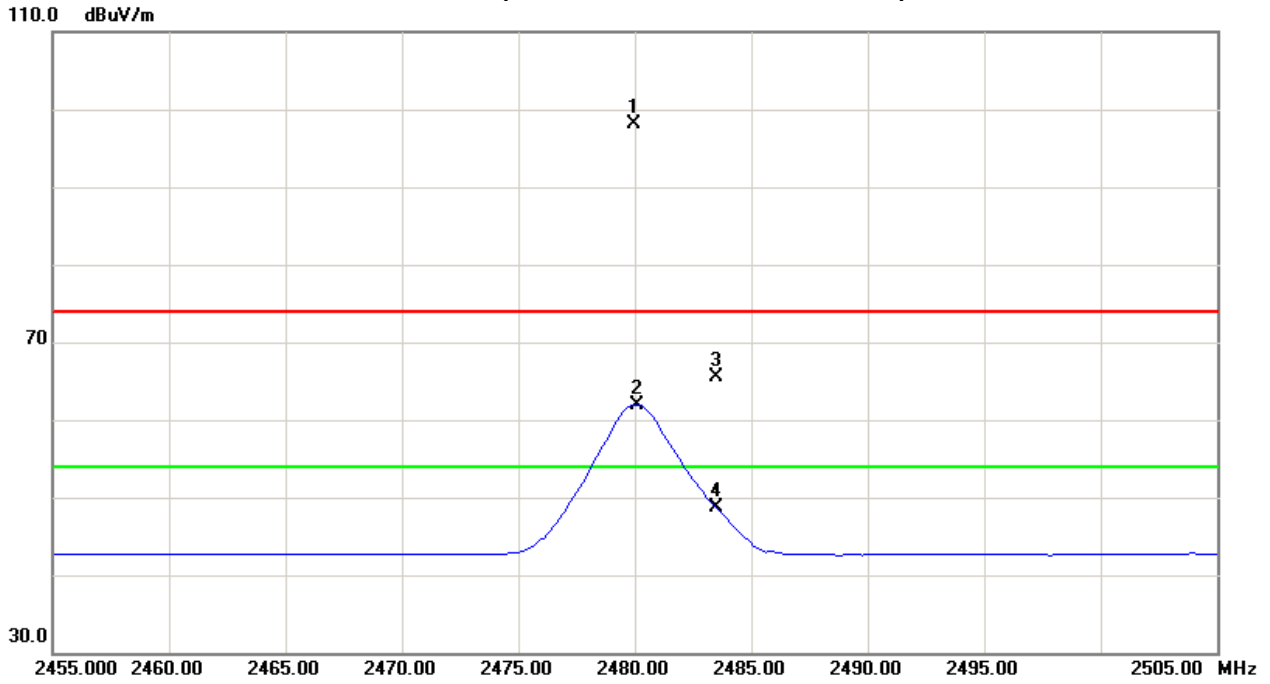



**5. BANDWIDTH TEST**

**5.1 Applied procedures / limit**

FCC Part15 (15.247) , Subpart C				
Section	Test Item	Limit	Frequency Range (MHz)	Result
15.247(a)(2)	Bandwidth	>= 500KHz (6dB bandwidth)	2400-2483.5	PASS

**5.1.1 MEASUREMENT INSTRUMENTS LIST**

Item	Kind of Equipment	Manufacturer	Type No.	Serial No.	Calibrated Until
1	Spectrum Analyzer	R&S	FSP_40	100185	Nov.16.2013

Remark: "N/A" denotes no model name, serial no. or calibration specified.  
All calibration period of Equipment List is One Year.

**5.1.2 TEST PROCEDURE**

- a. The EUT was directly connected to the spectrum analyzer and antenna output port as show in the block diagram below,
- b. Spectrum Setting : RBW= 100KHz, VBW=300KHz, Sweep time = 2.5 ms.

**5.1.3 DEVIATION FROM STANDARD**

No deviation.

**5.1.4 TEST SETUP**



**5.1.5 EUT OPERATION CONDITIONS**

The EUT tested system was configured as the statements of 4.1.6 Unless otherwise a special operating condition is specified in the follows during the testing.



**5.1.6 TEST RESULTS**

EUT :	Bluetooth speakers	Model Name. :	BTK-502
Temperature :	24 °C	Relative Humidity :	60 %
Pressure :	1016 hPa	Test Voltage :	DC 3.7V
Test Mode :	CH00, CH19, CH39 - 1Mbps		

Test Channel	Frequency (MHz)	Bandwidth (MHz)	LIMIT (MHz)
CH00	2402MHz	0.520	>=500KHz
CH19	2440MHz	0.510	>=500KHz
CH39	2480MHz	0.520	>=500KHz

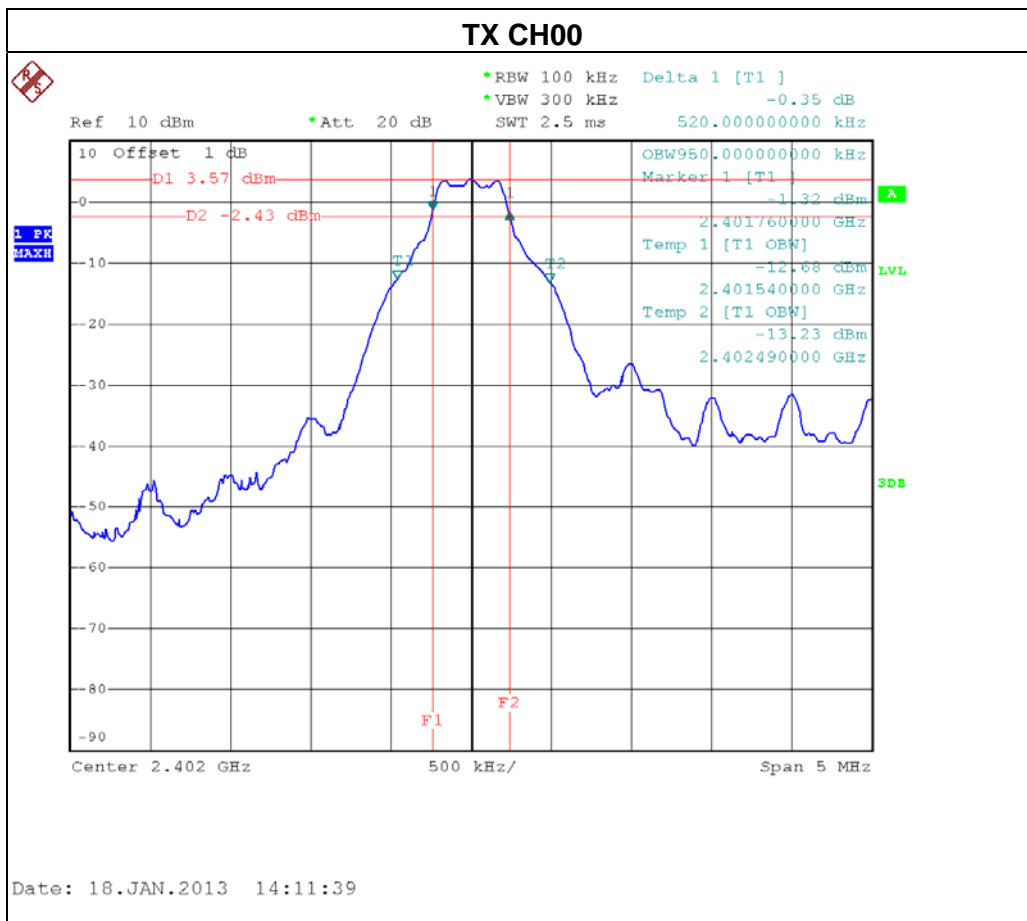

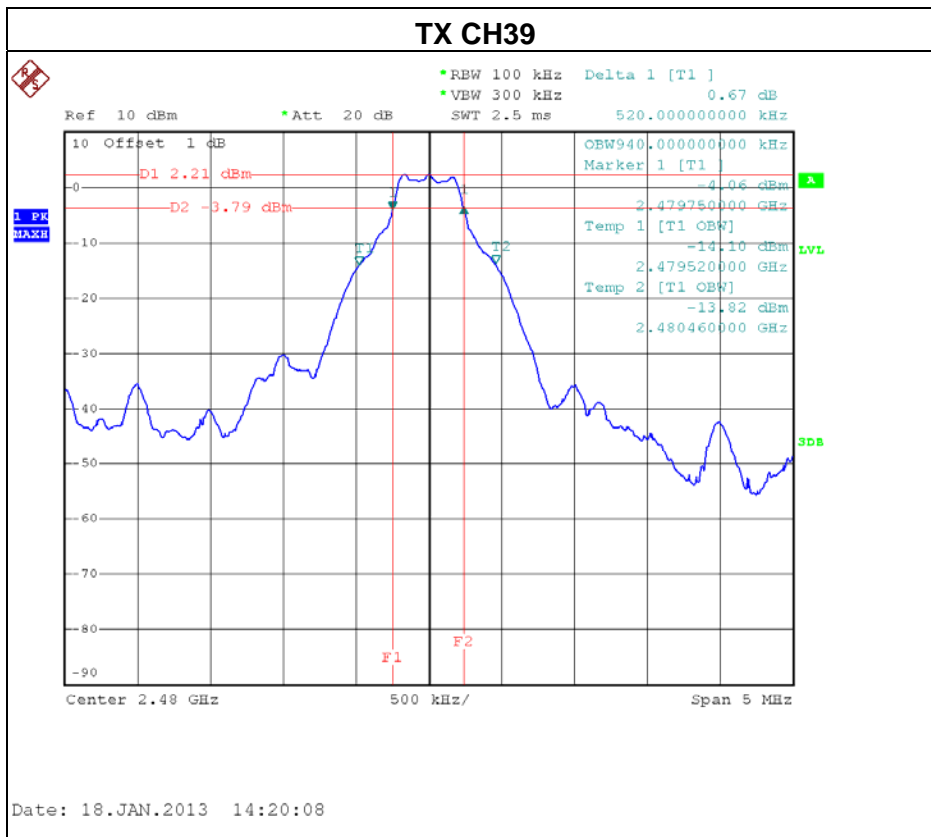
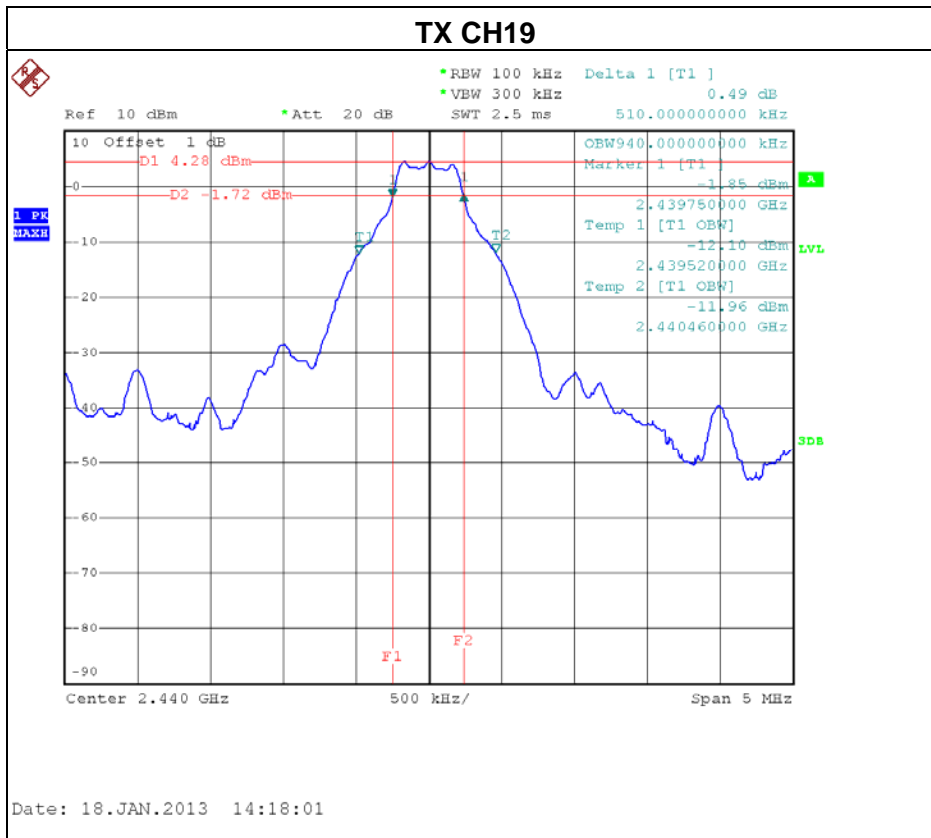





**6. MAXIMUM OUTPUT POWER TEST**

**6.1 Applied procedures / limit**

FCC Part15 (15.247) , Subpart C				
Section	Test Item	Limit	Frequency Range (MHz)	Result
15.247(b)(3)	Maximum Output Power	1 watt or 30dBm	2400-2483.5	PASS

**6.1.1 MEASUREMENT INSTRUMENTS LIST**

Item	Kind of Equipment	Manufacturer	Type No.	Serial No.	Calibrated Until
1	Power Meter	ANRITSU	ML2495A	1128009	Nov.01.2013
2	Pulse Power Sensor	ANRITSU	MA 2411B	1027500	Nov.01.2013

Remark: "N/A" denotes no model name, serial no. or calibration specified.  
 All calibration period of Equipment List is One Year.

**6.1.2 TEST PROCEDURE**

- a. The EUT was directly connected to the power meter and antenna output port as show in the block diagram below,
- b. The maximum peak conducted output power was performed in accordance with method 8.1.3 of FCC KDB 558074

**6.1.3 DEVIATION FROM STANDARD**

No deviation.

**6.1.4 TEST SETUP**

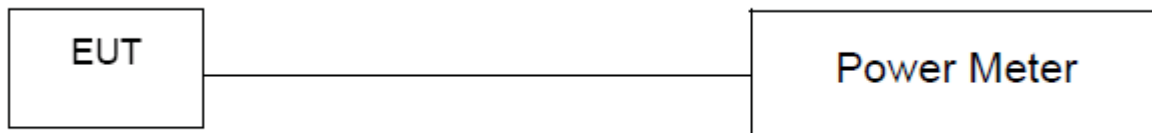

**6.1.5 EUT OPERATION CONDITIONS**

The EUT tested system was configured as the statements of 4.1.6 Unless otherwise a special operating condition is specified in the follows during the testing. Transmit output power was measured while the host equipment supply voltage was varied from 85 % to 115 % of the nominal rated supply voltage. No change in transmit output power was observed.



**6.1.6 TEST RESULTS**

EUT :	Bluetooth speakers	Model Name :	BTK-502
Temperature :	24 °C	Relative Humidity :	60 %
Pressure :	1016 hPa	Test Voltage :	DC 3.7V
Test Mode :	CH00, CH19, CH39 - 1Mbps		

**Maximum Output Power**

Test Channel	Frequency (MHz)	Output Power (dBm)	LIMIT (dBm)	LIMIT (W)
CH00	2402MHz	3.04	30	1
CH19	2440MHz	3.79	30	1
CH39	2480MHz	1.95	30	1



**7. ANTENNA CONDUCTED SPURIOUS EMISSION**

**7.1 Applied procedures / limit**

30dBc in any 100 kHz bandwidth outside the operating frequency band. In case the emission fall within the restricted band specified on 15.205(a), then the 15.209(a) limit in the table below has to be followed.

Frequencies (MHz)	Field Strength (micorvolts/meter)	Measurement Distance (meters)
0.009~0.490	2400/F(KHz)	300
0.490~1.705	24000/F(KHz)	30
1.705~30.0	30	30
30~88	100	3
88~216	150	3
216~960	200	3
960~1000	500	3

**7.1.1 MEASUREMENT INSTRUMENTS LIST**

Item	Kind of Equipment	Manufacturer	Type No.	Serial No.	Calibrated Until
1	Spectrum Analyzer	R&S	FSP_40	100185	Nov.16.2013

Remark: "N/A" denotes no model name, serial no. or calibration specified.  
All calibration period of Equipment List is One Year.

**7.1.2 TEST PROCEDURE**

- a. The EUT was directly connected to the spectrum analyzer and antenna output port as show in the block diagram below,
- b. Spectrum Setting : RBW= 100KHz, VBW=300KHz, Sweep time = 10 ms.

**7.1.3 DEVIATION FROM STANDARD**

No deviation.

**7.1.4 TEST SETUP**



**7.1.5 EUT OPERATION CONDITIONS**

The EUT tested system was configured as the statements of 4.1.6 Unless otherwise a special operating condition is specified in the follows during the testing.



**7.1.6 TEST RESULTS**

EUT :	Bluetooth speakers	Model Name :	BTK-502
Temperature :	24 °C	Relative Humidity :	60 %
Pressure :	1016 hPa	Test Voltage :	DC 3.7V
Test Mode :	CH00, CH19 , CH39 - 1Mbps		

Channel of Worst Data: CH00			
The max. radio frequency power in any 100kHz bandwidth outside the frequency band		The max. radio frequency power in any 100 kHz bandwidth outside the frequency band.	
FREQUENCY(MHz)	POWER(dBm)	FREQUENCY(MHz)	POWER(dBm)
2400.00	-49.05	2498.00	-58.16
Result			
In any 100kHz bandwidth outside the frequency band, the radio frequency power is at least 20dB below that in the 100kHz bandwidth within the band that contains the highest level of the desired power.			

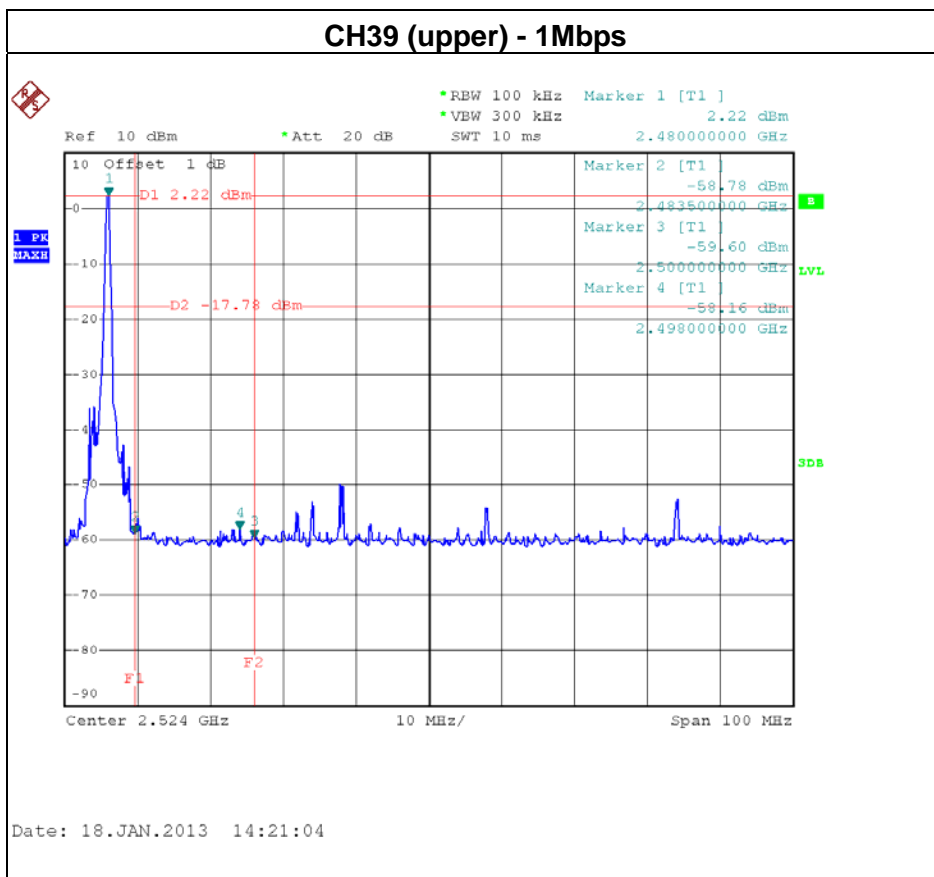
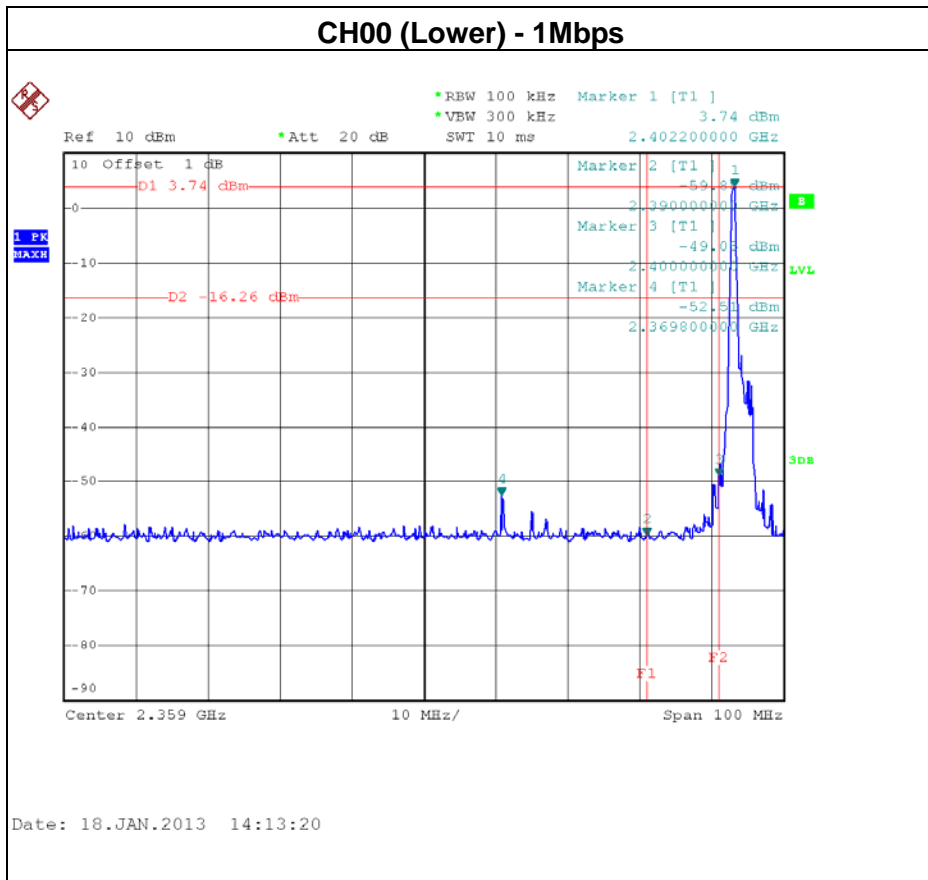

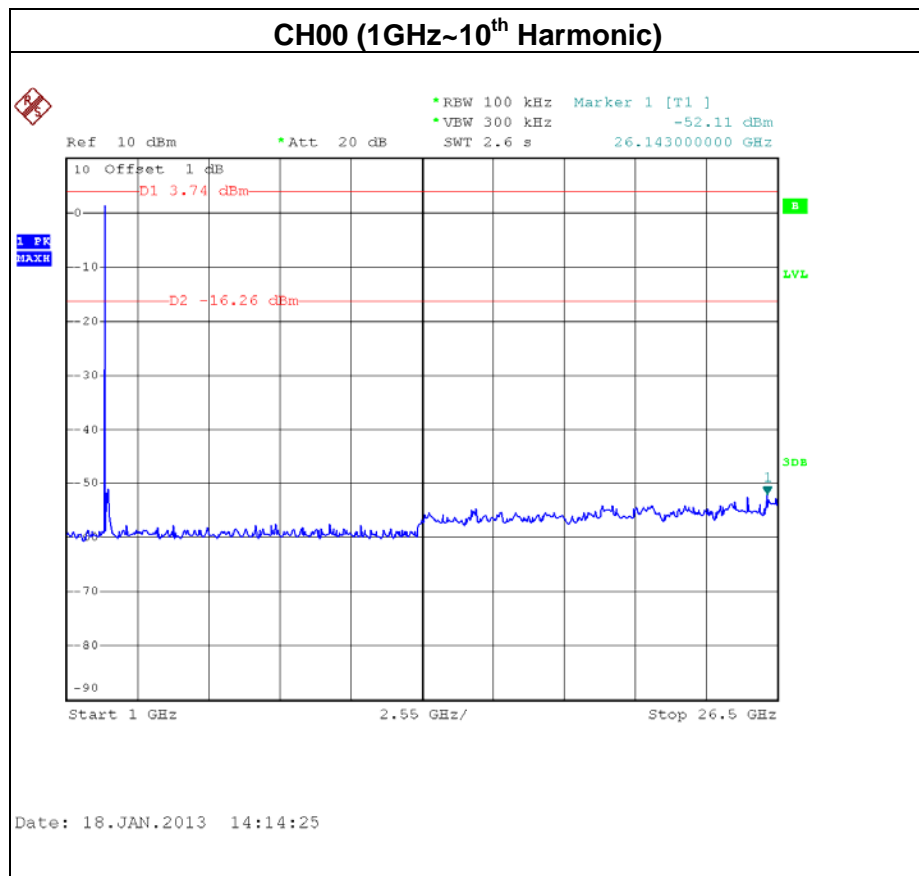
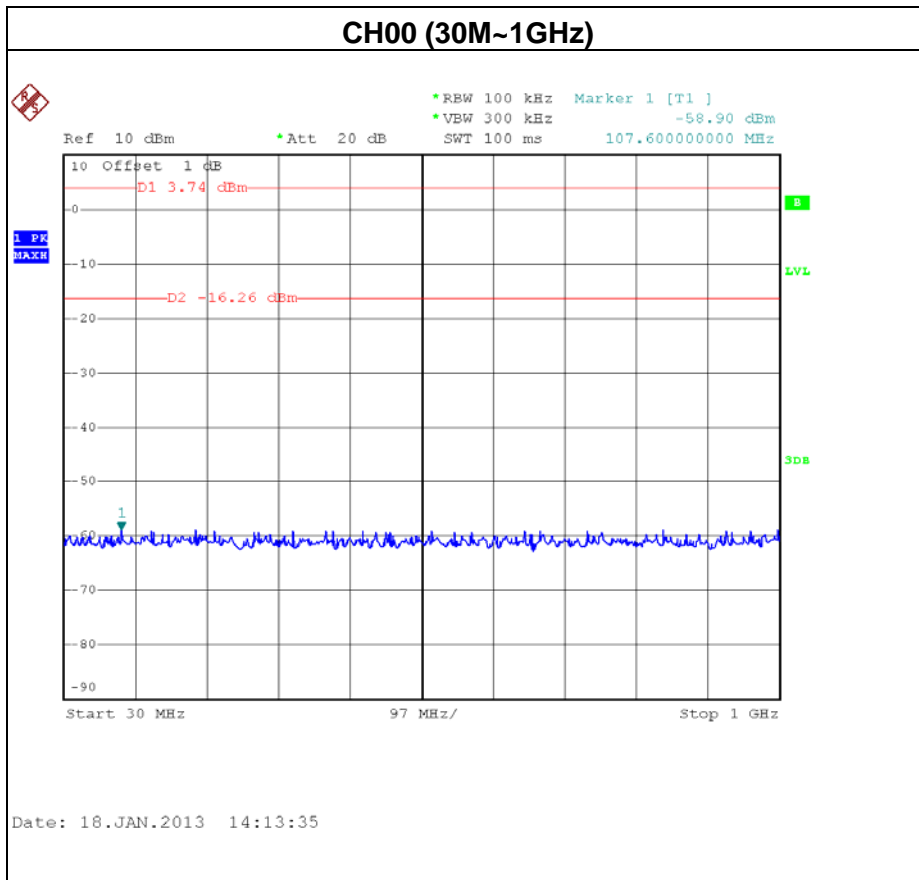

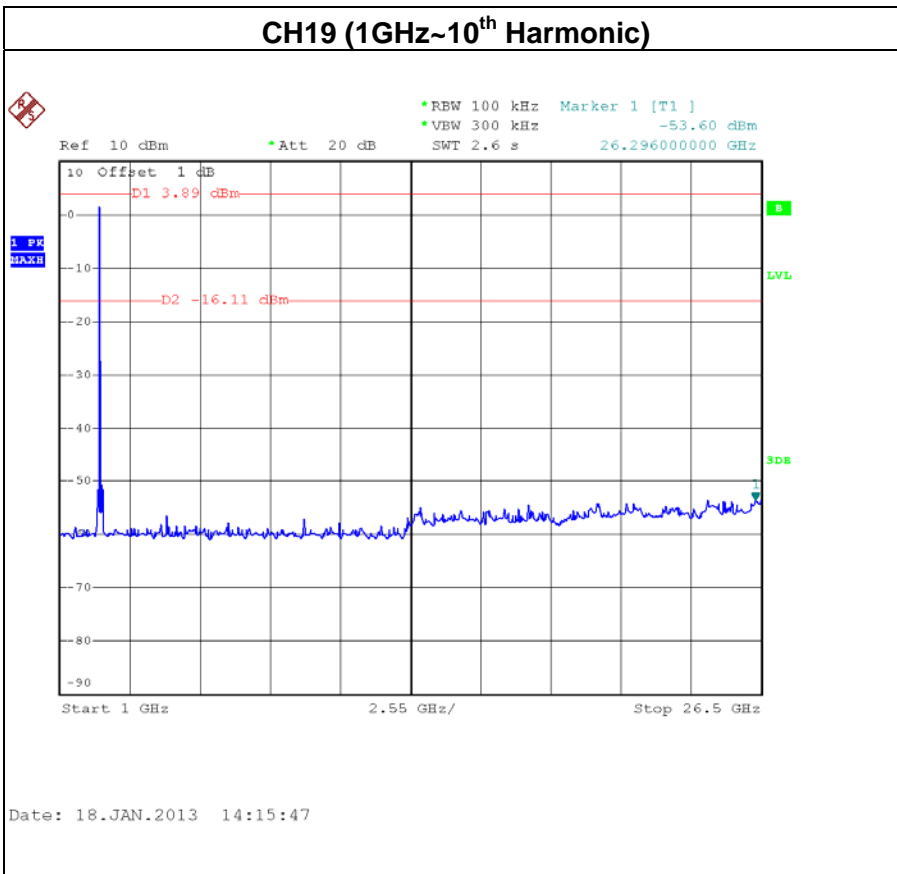
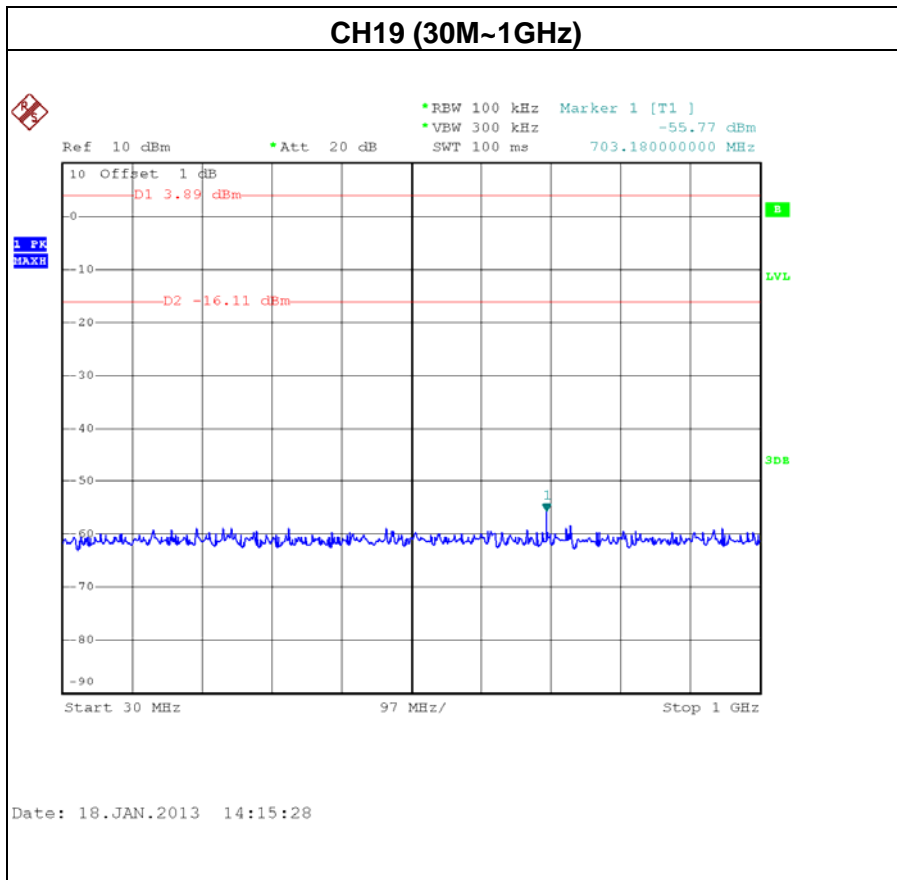

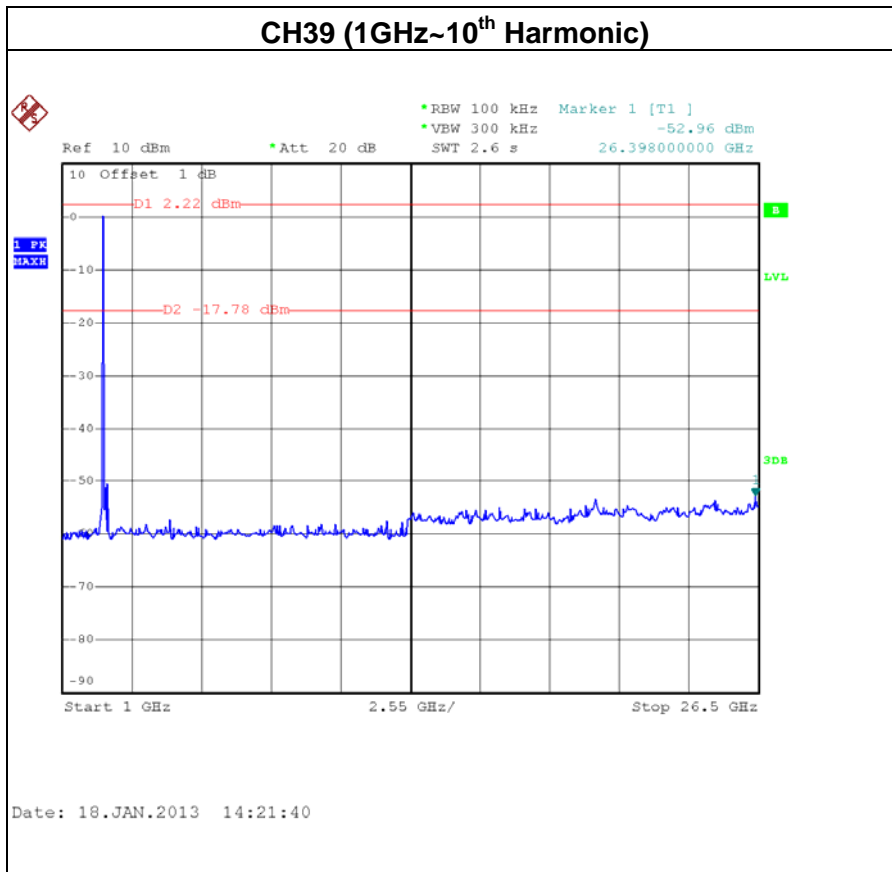
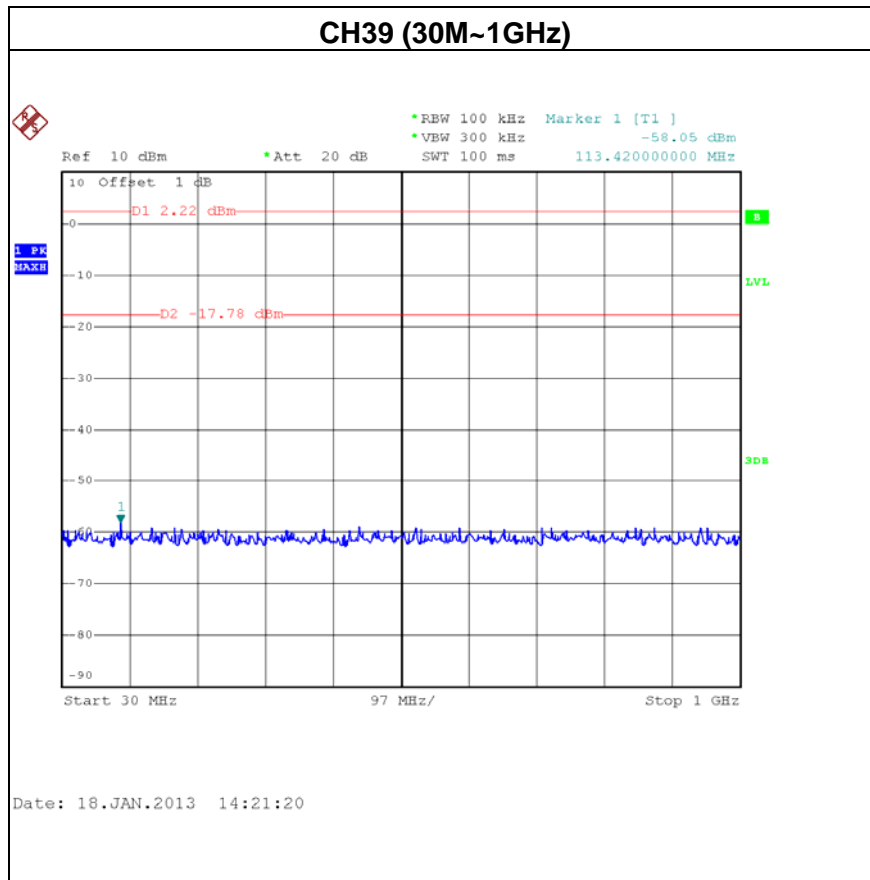





**8. POWER SPECTRAL DENSITY TEST**

**8.1 Applied procedures / limit**

FCC Part15 (15.247) , Subpart C				
Section	Test Item	Limit	Frequency Range (MHz)	Result
15.247(e)	Power Spectral Density	8 dBm (in any 3KHz)	2400-2483.5	PASS

**8.1.1 MEASUREMENT INSTRUMENTS LIST**

Item	Kind of Equipment	Manufacturer	Type No.	Serial No.	Calibrated Until
1	Spectrum Analyzer	R&S	FSP_40	100185	Nov.16.2013

Remark: "N/A" denotes no model name, serial no. or calibration specified.  
 All calibration period of Equipment List is One Year.

**8.1.2 TEST PROCEDURE**

- a. The EUT was directly connected to the spectrum analyzer and antenna output port as show in the block diagram below,
- b. Spectrum Setting : RBW=3KHz, VBW=10 KHz, Sweep time = auto.

**8.1.3 DEVIATION FROM STANDARD**

No deviation.

**8.1.4 TEST SETUP**

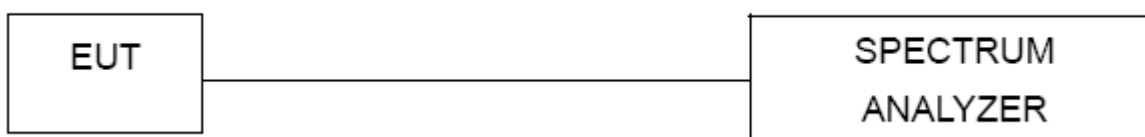

**8.1.5 EUT OPERATION CONDITIONS**

The EUT tested system was configured as the statements of 4.1.6 Unless otherwise a special operating condition is specified in the follows during the testing.



**8.1.6 TEST RESULTS**

EUT :	Bluetooth speakers	Model Name :	BTK-502
Temperature :	24 °C	Relative Humidity :	60 %
Pressure :	1016 hPa	Test Voltage :	DC 3.7V
Test Mode :	CH00, CH19, CH39 -1Mbps		

Test Channel	Frequency (MHz)	Power Density (dBm)	LIMIT (dBm)
CH00	2402MHz	-9.32	8
CH19	2440MHz	-8.57	8
CH39	2480MHz	-10.94	8

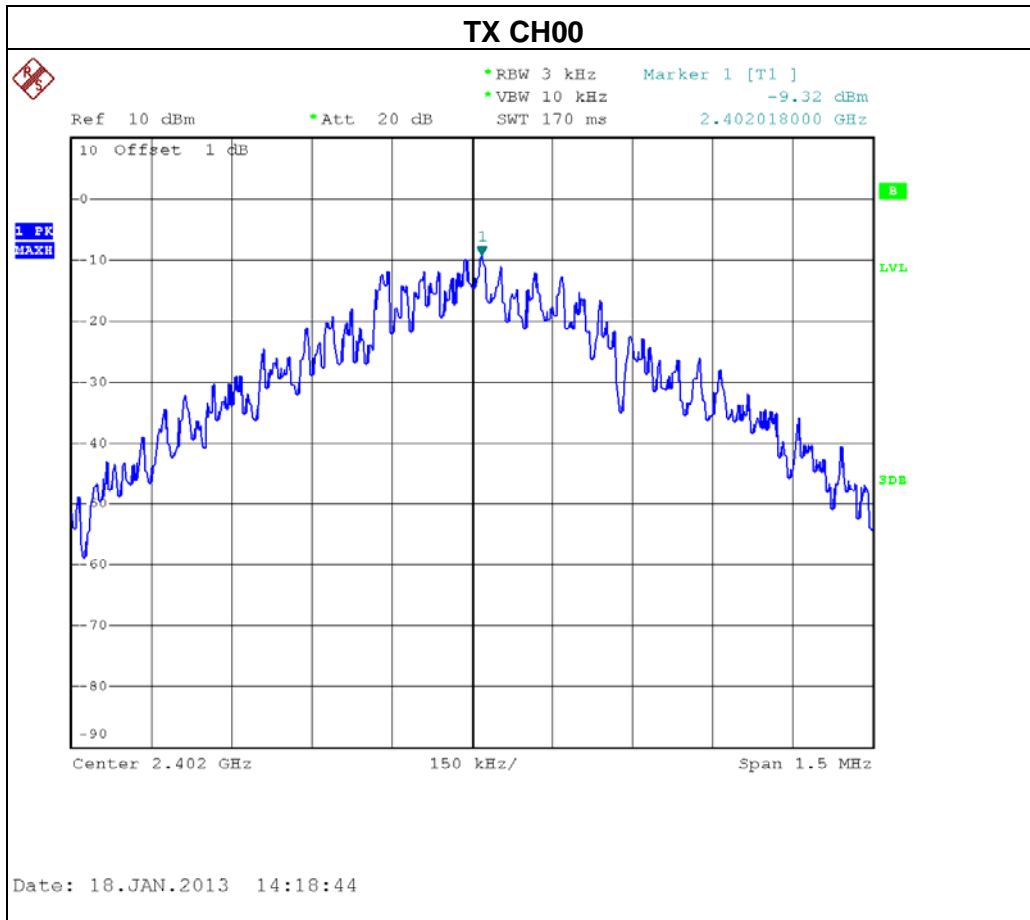

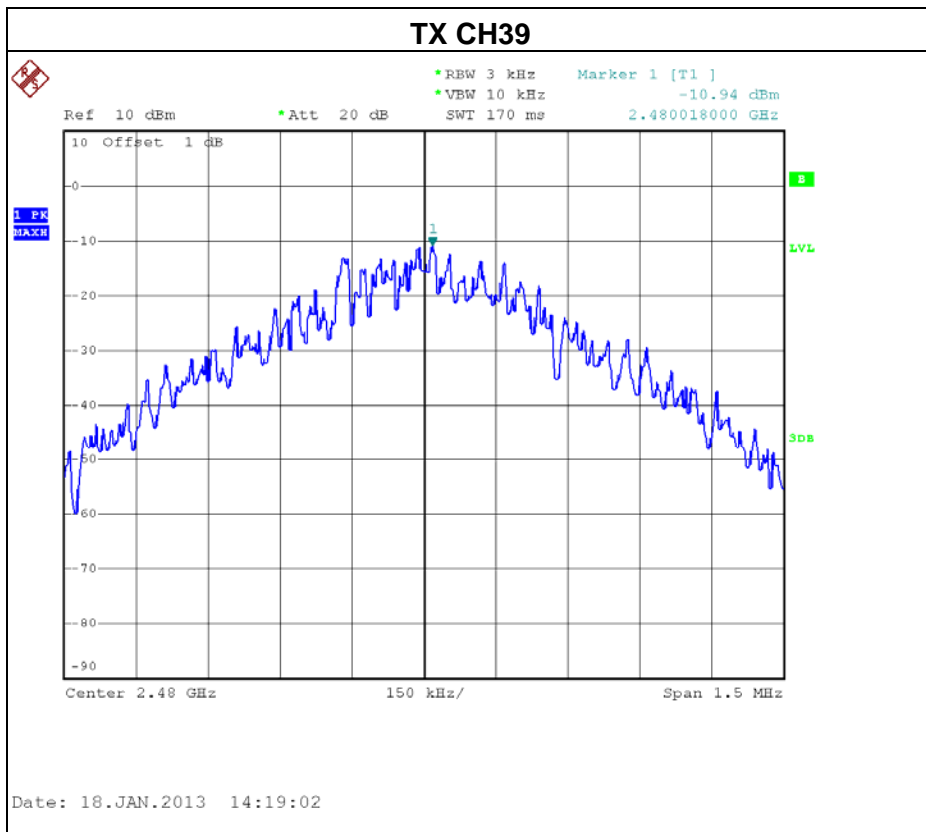
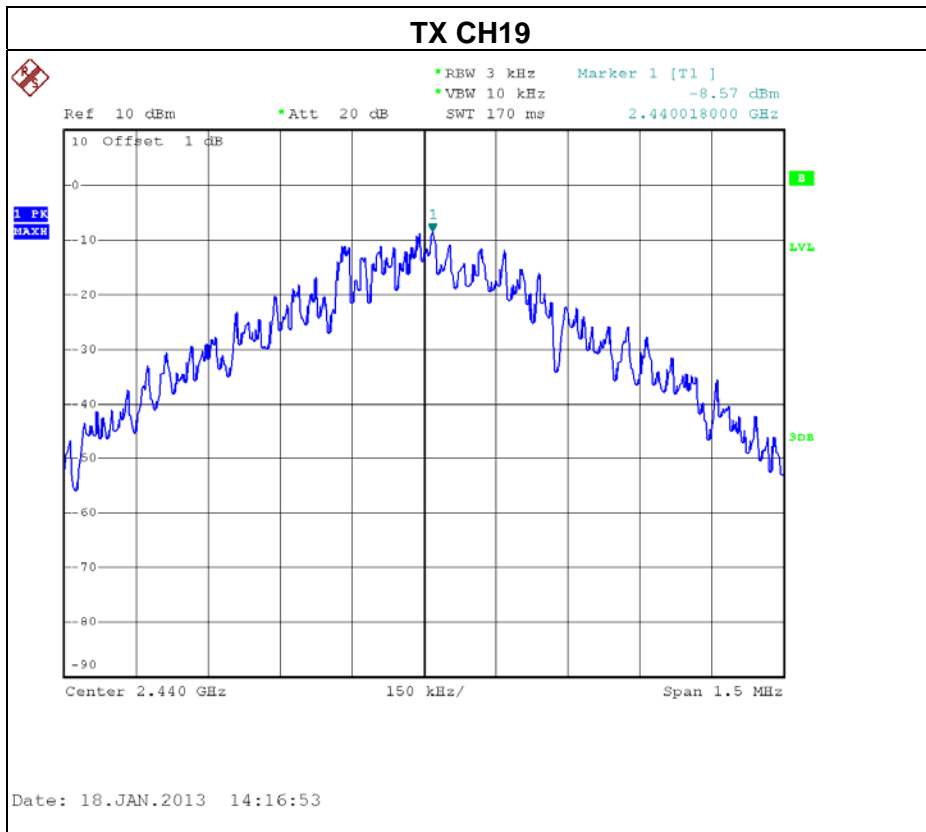



**9. EUT TEST PHOTO**

**Conducted Measurement Photos  
Bluetooth**





**Radiated Measurement Photos  
9K~30MHz**

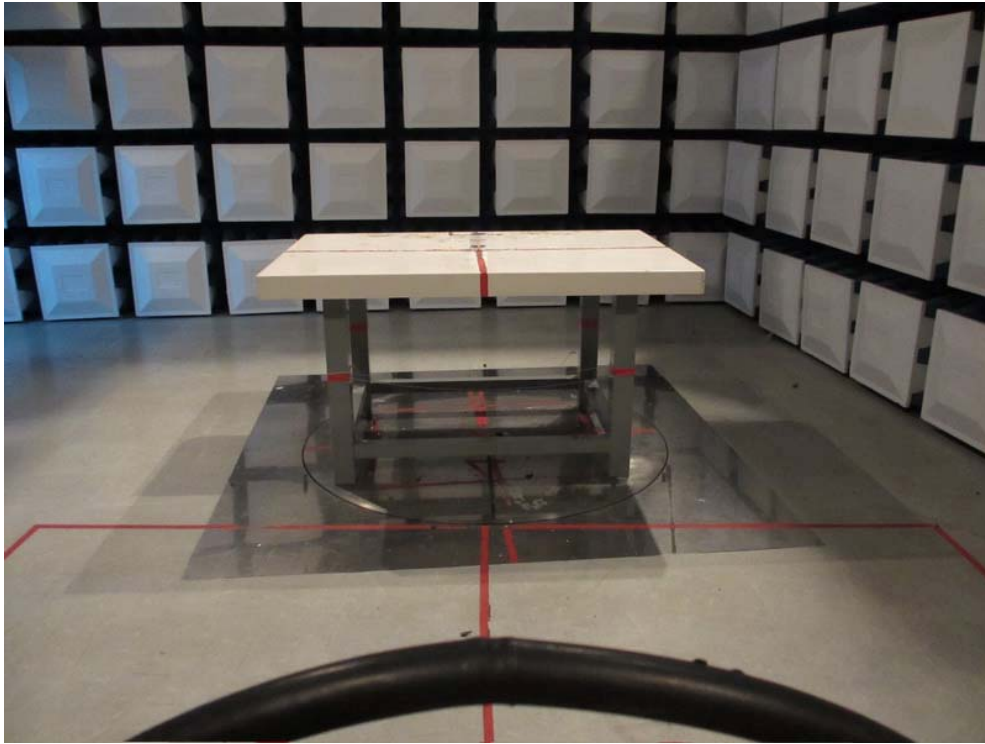



**Radiated Measurement Photos  
30M~1000MHz**

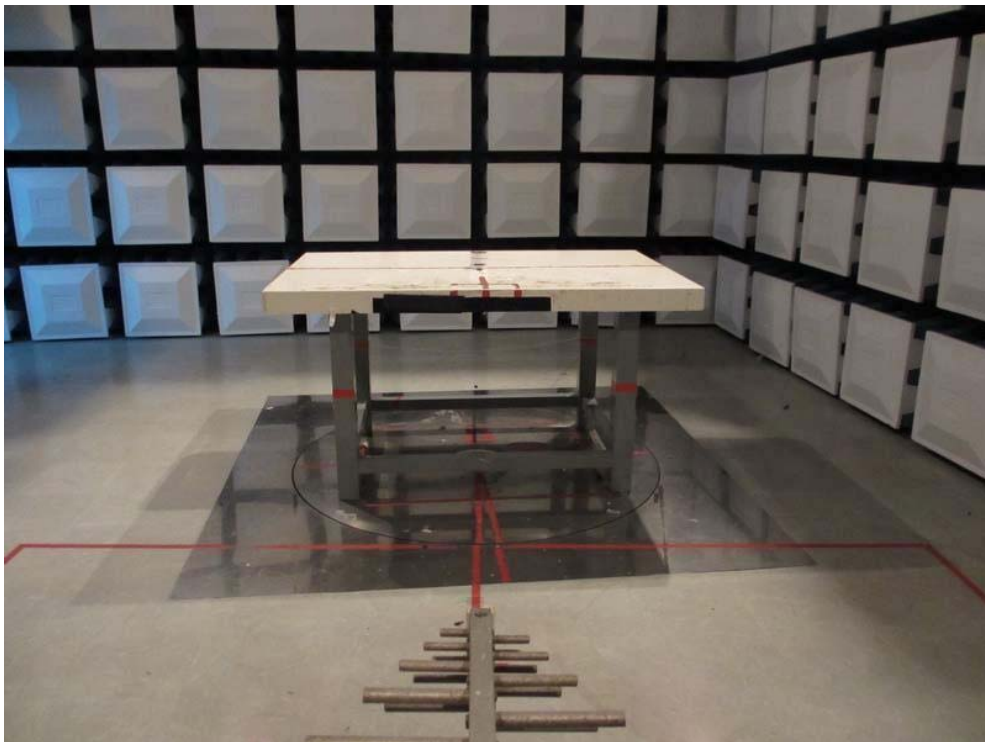
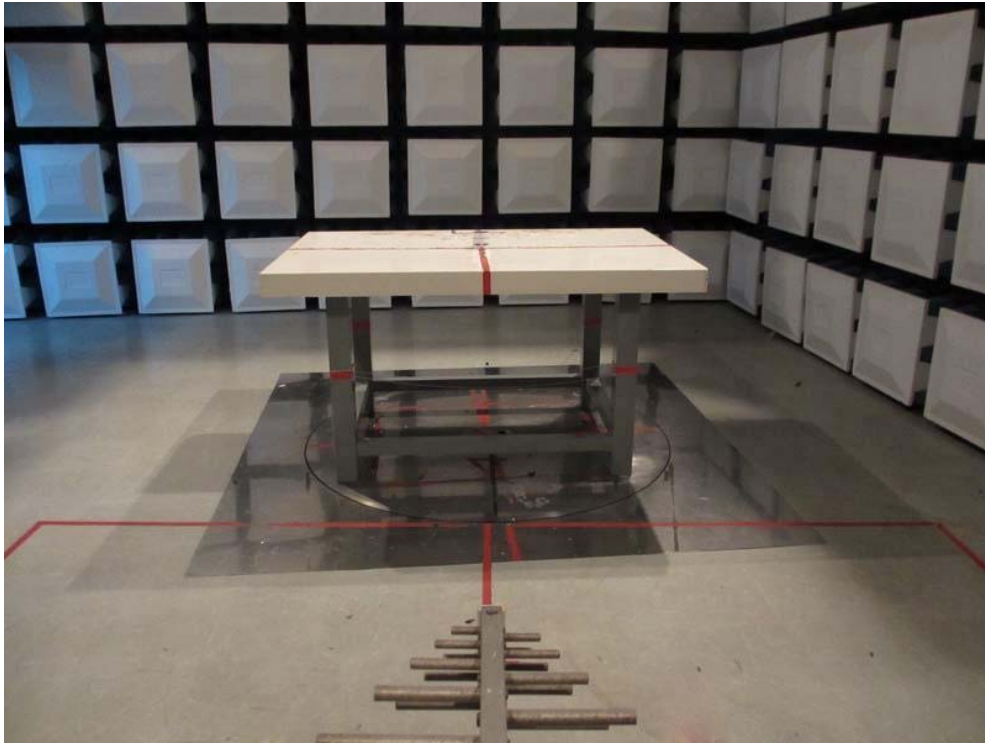



**Radiated Measurement Photos  
Above 1000MHz**

