



## Test Report

Product Name : Conference Phone  
Model No. : SP2  
FCC ID. : TIYSPRACHTSOHO

Applicant : Orient Direct Inc.  
Address : 2672 Bayshore Parkway Suite 900 Mountain View,  
CA94043 United States

Date of Receipt : 2008/12/22  
Issued Date : 2009/03/19  
Report No. : 08C278R-RFUSP06V01  
Version : V1.0

The test results relate only to the samples tested.

The test report shall not be reproduced except in full without the written approval of QuieTek Corporation.

# Test Report Certification

Issued Date : 2009/03/19

Report No. : 08C278R-RFUSP06V01



Product Name : Conference Phone  
 Applicant : Orient Direct Inc.  
 Address : 2672 Bayshore Parkway Suite 900 Mountain View, CA94043  
 United States  
 Manufacturer : TOPTTEAM TECHNOLOGY TAIWAN CO., LTD.  
 Model No. : SP2  
 FCC ID. : TIYSPRACHTSOHO  
 Rated Voltage : AC 120 V / 60 Hz  
 EUT Voltage : AC 120 V / 60 Hz  
 Trade Name : SPRACHT  
 Applicable Standard : FCC CFR Title 47 Part 15 Subpart C Section 15.247: 2008  
 Test Result : Complied

The test results relate only to the samples tested.

The test report shall not be reproduced except in full without the written approval of Quietek Corporation.

Documented By : Carol Tsai  
 ( Carol Tsai Senior / Engineering Adm. Specialist )  
 Tested By : Sheena Huang  
 ( Sheena Huang / Engineer )  
 Approved By : Roy Wang  
 ( Roy Wang / Manager )

TABLE OF CONTENTS

Description	Page
<b>1. General Information .....</b>	<b>5</b>
1.1. EUT Description .....	5
1.2. Operational Description .....	7
1.3. Test Mode .....	8
1.4. Tested System Details.....	9
1.5. Configuration of tested System .....	10
1.6. EUT Exercise Software .....	11
1.7. Test Facility .....	12
<b>2. Conducted Emission .....</b>	<b>14</b>
2.1. Test Equipment .....	14
2.2. Test Setup .....	14
2.3. Limits.....	15
2.4. Test Procedure .....	15
2.5. Test Specification .....	15
2.6. Test Result .....	16
2.7. Test Photo .....	18
<b>3. Peak Power Output .....</b>	<b>19</b>
3.1. Test Equipment .....	19
3.2. Test Setup .....	19
3.3. Test procedures.....	19
3.4. Limits.....	19
3.5. Test Specification .....	19
3.6. Test Result .....	20
<b>4. Radiated Emission .....</b>	<b>23</b>
4.1. Test Equipment .....	23
4.2. Test Setup .....	23
4.3. Limits.....	24
4.4. Test Procedure .....	24
4.5. Test Specification .....	24
4.6. Test Result .....	25
4.7. Test Photo .....	39
<b>5. RF antenna conducted test.....</b>	<b>41</b>
5.1. Test Equipment .....	41
5.2. Test Setup .....	41
5.3. Limits.....	42
5.4. Test Procedure .....	42
5.5. Test Specification .....	42
5.6. Test Result .....	43
<b>6. Band Edge .....</b>	<b>58</b>
6.1. Test Equipment .....	58
6.2. Test Setup .....	58
6.3. Limits.....	59
6.4. Test Procedure .....	59

6.5.	Test Specification .....	59
6.6.	Test Result .....	60
<b>7.</b>	<b>Number of hopping frequency .....</b>	<b>68</b>
7.1.	Test Equipment .....	68
7.2.	Test Setup .....	68
7.3.	Limits.....	69
7.4.	Test Procedures .....	69
7.5.	Test Specification .....	69
7.6.	Test Result .....	70
<b>8.</b>	<b>Carrier Frequency Separation .....</b>	<b>74</b>
8.1.	Test Equipment .....	74
8.2.	Test Setup .....	74
8.3.	Limits.....	74
8.4.	Test Procedures .....	74
8.5.	Test Specification .....	74
8.6.	Test Result .....	75
<b>9.</b>	<b>Occupied Bandwidth .....</b>	<b>78</b>
9.1.	Test Equipment .....	78
9.2.	Test Setup .....	78
9.3.	Limits.....	79
9.4.	Test Procedures .....	79
9.5.	Test Specification .....	79
9.6.	Test Result .....	80
<b>10.</b>	<b>Dwell Time .....</b>	<b>83</b>
10.1.	Test Equipment .....	83
10.2.	Test Setup .....	83
10.3.	Limits.....	84
10.4.	Test Procedures .....	84
10.5.	Test Specification .....	84
10.6.	Test Result .....	85
Attachement.....		89
	EUT Photograph .....	89

## 1. General Information

### 1.1. EUT Description

Product Name	Conference Phone
Trade Name	SPRACHT
Model No.	SP2
Frequency Range	2402~2480MHz
Channel Number	79
Type of Modulation	FHSS
Channel Control	Auto
Antenna Type	Inverted F
Antenna Gain	1.52dBi

Component	
LAN Cable	Non-Shielded, 5m
Power Adapter	SUNNY, SYS1319-3015 I/P: 100-240V 1.0A Max 50~60Hz O/P: +15V, 2.0A Power Cord: Non-Shielded, 1.8m

Working Frequency of Each Channel							
Channel	Frequency	Channel	Frequency	Channel	Frequency	Channel	Frequency
Channel 00	2402 MHz	Channel 20	2422 MHz	Channel 40	2442 MHz	Channel 60	2462 MHz
Channel 01	2403 MHz	Channel 21	2423 MHz	Channel 41	2443 MHz	Channel 61	2463 MHz
Channel 02	2404 MHz	Channel 22	2424 MHz	Channel 42	2444 MHz	Channel 62	2464 MHz
Channel 03	2405 MHz	Channel 23	2425 MHz	Channel 43	2445 MHz	Channel 63	2465 MHz
Channel 04	2406 MHz	Channel 24	2426 MHz	Channel 44	2446 MHz	Channel 64	2466 MHz
Channel 05	2407 MHz	Channel 25	2427 MHz	Channel 45	2447 MHz	Channel 65	2467 MHz
Channel 06	2408 MHz	Channel 26	2428 MHz	Channel 46	2448 MHz	Channel 66	2468 MHz
Channel 07	2409 MHz	Channel 27	2429 MHz	Channel 47	2449 MHz	Channel 67	2469 MHz
Channel 08	2410 MHz	Channel 28	2430 MHz	Channel 48	2450 MHz	Channel 68	2470 MHz
Channel 09	2411 MHz	Channel 29	2431 MHz	Channel 49	2451 MHz	Channel 69	2471 MHz
Channel 10	2412 MHz	Channel 30	2432 MHz	Channel 50	2452 MHz	Channel 70	2472 MHz
Channel 11	2413 MHz	Channel 31	2433 MHz	Channel 51	2453 MHz	Channel 71	2473 MHz
Channel 12	2414 MHz	Channel 32	2434 MHz	Channel 52	2454 MHz	Channel 72	2474 MHz
Channel 13	2415 MHz	Channel 33	2435 MHz	Channel 53	2455 MHz	Channel 73	2475 MHz
Channel 14	2416 MHz	Channel 34	2436 MHz	Channel 54	2456 MHz	Channel 74	2476 MHz
Channel 15	2417 MHz	Channel 35	2437 MHz	Channel 55	2457 MHz	Channel 75	2477 MHz
Channel 16	2418 MHz	Channel 36	2438 MHz	Channel 56	2458 MHz	Channel 76	2478 MHz
Channel 17	2419 MHz	Channel 37	2439 MHz	Channel 57	2459 MHz	Channel 77	2479 MHz
Channel 18	2420 MHz	Channel 38	2440 MHz	Channel 58	2460 MHz	Channel 78	2480 MHz
Channel 19	2421 MHz	Channel 39	2441 MHz	Channel 59	2461 MHz		

The system receivers have input bandwidths that match the hopping channel bandwidths of their corresponding transmitters and shift frequencies in synchronization with the transmitted signals. Frequency hopping spread spectrum systems are not required to employ all available hopping channels during each transmission. The transmitter is presented with a continuous data stream. In addition, a system employing short transmission bursts must comply with the definition of a frequency hopping system and must distribute its 79 channels and over the minimum number of hopping channels (75 channels).

The incorporation of intelligence within a frequency hopping spread spectrum system that permits the system to recognize other users within the spectrum band so that it individually and independently chooses and adapts its hop sets to avoid hopping on occupied channels is permitted. The coordination of frequency hopping systems in any other manner for the express purpose of avoiding the simultaneous occupancy of individual hopping frequencies by multiple transmitters is not permitted.

Note:

1. This device is a Conference Phone included a 2.4GHz receiving function, and 2.4GHz transmitting function.
2. These tests were conducted on a sample of the equipment for the purpose of demonstrating compliance with Part 15 Subpart C Paragraph 15.247 for spread spectrum devices.
3. Regards to the frequency band operation; the lowest - middle and highest frequency of channel were selected to perform the test, and then shown on this report.
4. This device is a composite device in accordance with Part 15 regulations. The function receiving was measured and made a test report that the report number is 08C278R-RFUSP01V02 under Declaration of Conformity.

**1.3. Test Mode**

QuieTek has verified the construction and function in typical operation. All the test modes were carried out with the EUT in transmitting operation, which was shown in this test report and defined as follows:

Pre-Test Mode	
EMI	Mode 1: Transmit
Final Test Mode	
EMI	Mode 1: Transmit

Emission	
Conducted Emission	Yes
Peak Power Output	Yes
Radiated Emission	Yes
Band Edge	Yes
Channel of Number	Yes
Channel Separation	Yes
Occupied Bandwidth	Yes
Dwell Time	Yes

#### 1.4. Tested System Details

The types for all equipments, plus descriptions of all cables used in the tested system (including inserted cards) are:

	Product	Manufacturer	Model No.	Serial No.	FCC ID	Power Cord
1	Monitor	CHI MEI	A170E1-09	3UC120954WA0079	DoC	Non-Shielded, 1.8m
2	Speaker	TOPTEAM	FM-6B	N/A	DoC	--
3	Speaker	TOPTEAM	FM-6B	N/A	DoC	--
4	Fixture	TOPTEAM	N/A	N/A	DoC	--
5	Notebook PC	DELL	LATITUDE D400	GK43D1S	DoC	Non-Shielded, 1.7m, one ferrite core bonded
6	USB Mouse	Logitech	M-UV83	LZE35006044	DoC	--
7	USB Mouse	Logitech	M-UV83	LZE35006065	DoC	--
8	Microphone & Earphone	Fujiei	SBZ-38	N/A	DoC	--
9	Walkman	TOBISHI	TB-21984	N/A	DoC	--
10	Digital 8 (D8)	SONY	DCR-TRV110	P35209	DoC	--



1.5. Configuration of tested System

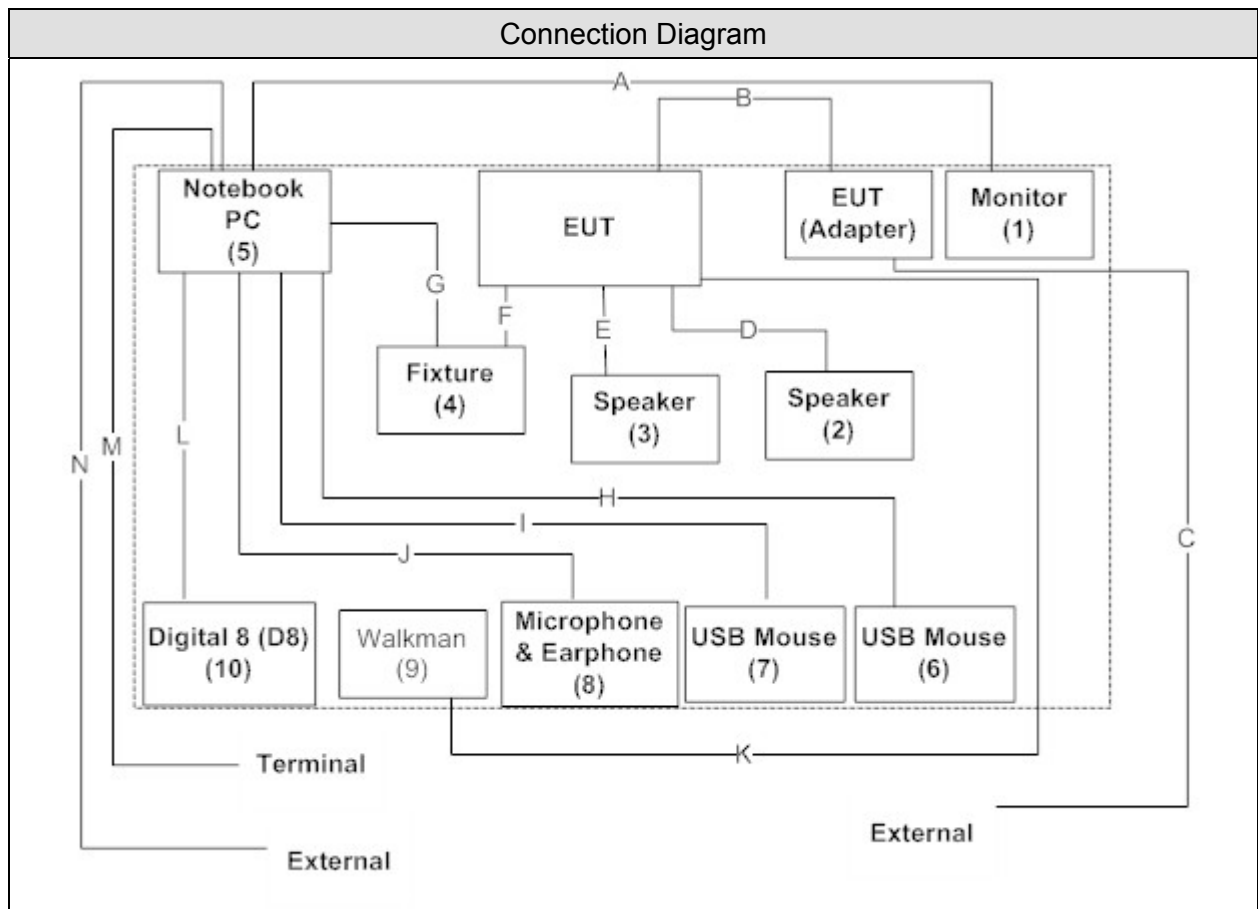

Signal Cable Type		Signal cable Description
A	VGA Cable	Shielded, 1.6m, one ferrite core bonded.
B	LAN Cable	Non-Shielded, 5m
C	Telecom Cable	Non-Shielded, 10m
D	Speaker Cable	Non-Shielded, 1.8m
E	Speaker Cable	Non-Shielded, 1.8m
F	Power Line	Non-Shielded, 0.05m
G	RS 232 Cable	Shielded, 1m
H	USB Mouse Cable	Shielded, 1m
I	USB Mouse Cable	Shielded, 1m
J	Microphone & Earphone Cable	Non-Shielded, 1.2m
K	Walkman Cable	Non-Shielded, 1.6m
L	1394 Cable	Shielded, 1m
M	LAN Cable	Non-Shielded, 10m
N	Telecom Cable	Non-Shielded, 10m

**1.6. EUT Exercise Software**

1	Setup the EUT and simulators as shown on 1.5.
2	Turn on the power of all equipment.
3	The EUT will play the function from Bluetooth program.
4	Verify the model operation.
5	Repeat the above procedure (3) to (4).

## 1.7. Test Facility

Ambient conditions in the laboratory:

Items	Test Item	Required (IEC 68-1)	Actual
Temperature (°C)	FCC PART 15 B 15.107 Conducted Emission	15 - 35	25
Humidity (%RH)		25 - 75	50
Barometric pressure (mbar)		860 - 1060	950-1000
Temperature (°C)	FCC PART 15 C 15.247 Peak Power Output (FHSS)	15 - 35	24
Humidity (%RH)		25 - 75	49
Barometric pressure (mbar)		860 - 1060	950-1000
Temperature (°C)	FCC PART 15 C 15.247 Radiated Emission (FHSS)	15 - 35	25
Humidity (%RH)		25 - 75	54
Barometric pressure (mbar)		860 - 1060	950-1000
Temperature (°C)	FCC PART 15 C 15.247 Band Edge (FHSS)	15 - 35	25
Humidity (%RH)		25 - 75	50
Barometric pressure (mbar)		860 - 1060	950-1000
Temperature (°C)	FCC PART 15 C 15.247 Channel Of Number (FHSS)	15 - 35	24
Humidity (%RH)		25 - 75	49
Barometric pressure (mbar)		860 - 1060	950-1000
Temperature (°C)	FCC PART 15 C 15.247 Channel Separation (FHSS)	15 - 35	24
Humidity (%RH)		25 - 75	50
Barometric pressure (mbar)		860 - 1060	950-1000
Temperature (°C)	FCC PART 15 C 15.247 Occupied Bandwidth (FHSS)	15 - 35	24
Humidity (%RH)		25 - 75	50
Barometric pressure (mbar)		860 - 1060	950-1000
Temperature (°C)	FCC PART 15 C 15.247 Dwell Time (FHSS)	15 - 35	24
Humidity (%RH)		25 - 75	50
Barometric pressure (mbar)		860 - 1060	950-1000

Site Description:

August 30, 2007 File on  
Federal Communications Commission  
Laboratory Division  
7435 Oakland Mills Road  
Columbia, MD 21046  
Registration Number: 365520



Accredited by TAF  
Accreditation Number: 1313  
Effective through: December 27, 2010



Accredited by NVLAP  
NVLAP Lab Code: 200347-0  
Effective through: September 30, 2009



Site Name: Quietek Corporation

Site Address: No.75-1, Wang-Yeh Valley, Yung-Hsing,  
Chiung-Lin, Hsin-Chu County,  
Taiwan, R.O.C.  
TEL : 886-3-592-8858 / FAX : 886-3-592-8859  
E-Mail : service@quietek.com

**2. Conducted Emission**

**2.1. Test Equipment**

The following test equipment are used during the test:

Conducted Emission / SR2

Instrument	Manufacturer	Type No.	Serial No	Cal. Date
4-Wire ISN	R & S	ENY 41	837032/001	2008/04/15
Artificial Mains Network	R & S	ENV4200	848411/010	2008/03/13
Double 2-Wire ISN	R & S	ENY 22	835354/008	2008/04/15
LISN	R & S	ESH3-Z5	825562/002	2008/03/31
Pulse Limiter	R & S	ZSH3Z2	357.8810.54	2008/07/19
Test Receiver	R & S	ESCS 30	100122	2008/02/21

Note: All equipment upon which need to calibrated are with calibration period of 1 year.

**2.2. Test Setup**

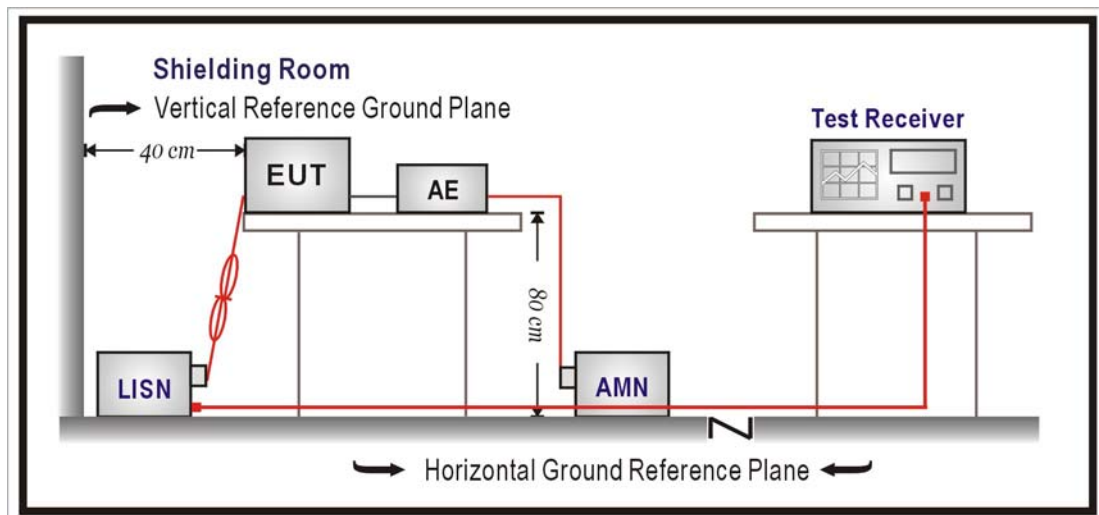

**2.3. Limits**

<b>FCC Part 15 Subpart C Paragraph 15.207 Limits (dBuV)</b>		
Frequency MHz	QP	AV
0.15 - 0.50	66-56	56-46
0.50-5.0	56	46
5.0 - 30	60	50

Remarks : In the above table, the tighter limit applies at the band edges.

**2.4. Test Procedure**

The EUT was setup and tested according to ANSI C63.4, 2003.

The EUT and simulators are connected to the main power through a line impedance stabilization network (L.I.S.N.). This provides a 50 ohm /50uH coupling impedance for the measuring equipment. The peripheral devices are also connected to the main power through a LISN that provides a 50ohm/50uH coupling impedance with 50ohm termination. (Please refers to the block diagram of the test setup and photographs.)

Both sides of A.C. line are checked for maximum conducted interference. In order to find the maximum emission, the relative positions of equipment and all of the interface cables must be changed according to ANSI C63.4: 2003 on conducted measurement.

Conducted emissions were invested over the frequency range from 0.15MHz to 30MHz using a receiver bandwidth of 9kHz.

**2.5. Test Specification**

According to FCC Part 15 Subpart C Paragraph 15.207: 2008

2.6. Test Result

Site : SR2	Time : 2008/12/24 - 17:51
Limit : CISPR_B_00M_QP	Margin : 6
Probe : SR2-LISN(16A) - Line1	Power : AC 120v/60Hz
EUT : Conference Phone	Note : TX

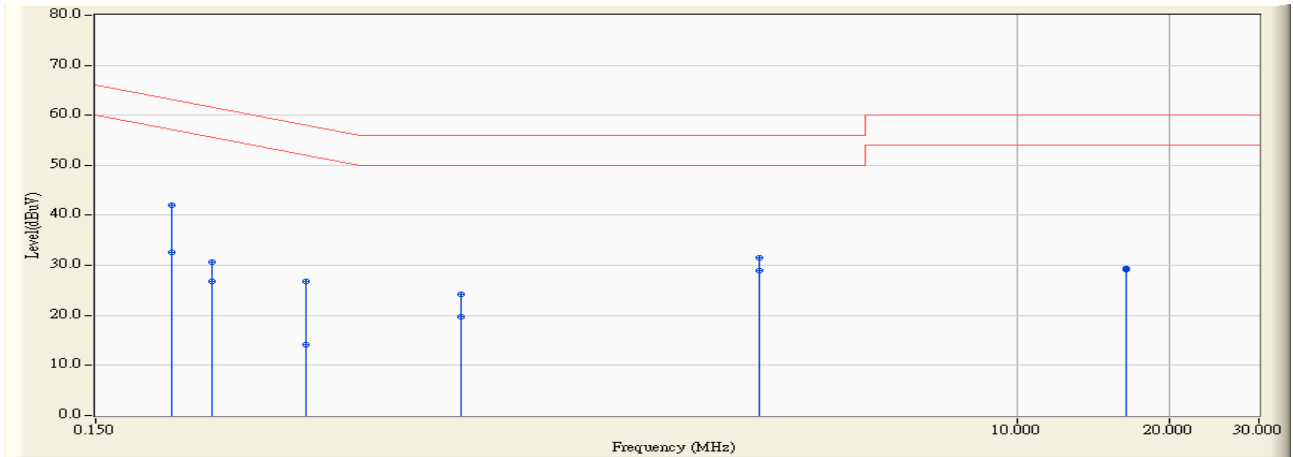

		Frequency (MHz)	Correct Factor (dB)	Reading Level (dBuV)	Measure Level (dBuV)	Margin (dB)	Limit (dBuV)	Detector Type
1		0.212	9.666	32.460	42.126	-20.981	63.107	QUASIPeAK
2		0.212	9.666	23.030	32.696	-20.411	53.107	AVERAGE
3		0.255	9.688	20.990	30.678	-30.900	61.577	QUASIPeAK
4		0.255	9.688	17.070	26.758	-24.820	51.577	AVERAGE
5		0.392	9.762	17.080	26.841	-31.176	58.017	QUASIPeAK
6		0.392	9.762	4.390	14.151	-33.866	48.017	AVERAGE
7		0.795	9.820	14.400	24.220	-31.780	56.000	QUASIPeAK
8		0.795	9.820	9.890	19.710	-26.290	46.000	AVERAGE
9		3.076	9.824	21.670	31.494	-24.506	56.000	QUASIPeAK
10	*	3.076	9.824	19.060	28.884	-17.116	46.000	AVERAGE
11		16.384	10.175	19.260	29.435	-30.565	60.000	QUASIPeAK
12		16.384	10.175	18.920	29.095	-20.905	50.000	AVERAGE

Note:

1. All Reading Levels are Quasi-Peak and average value.
2. " \* ", means this data is the worst emission level.
3. Measurement Level = Reading Level + Correct Factor.

Site : SR2	Time : 2008/12/24 - 17:54
Limit : CISPR_B_00M_QP	Margin : 6
Probe : SR2-LISN(16A) - Line2	Power : AC 120v/60Hz
EUT : Conference Phone	Note : TX

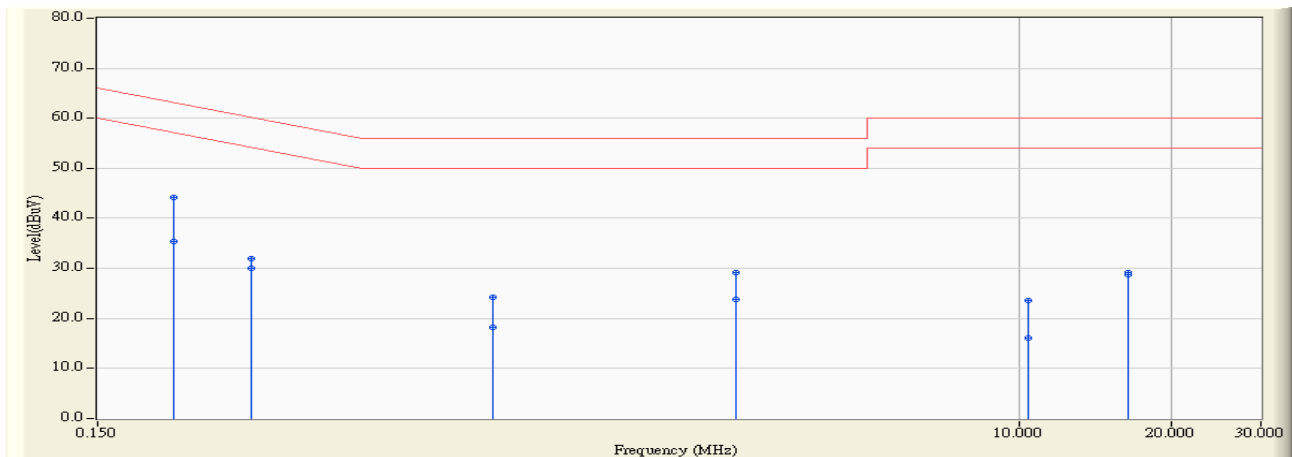

		Frequency (MHz)	Correct Factor (dB)	Reading Level (dBuV)	Measure Level (dBuV)	Margin (dB)	Limit (dBuV)	Detector Type
1		0.212	9.688	34.490	44.178	-18.929	63.107	QUASPEAK
2	*	0.212	9.688	25.790	35.478	-17.629	53.107	AVERAGE
3		0.302	9.723	22.190	31.913	-28.265	60.178	QUASPEAK
4		0.302	9.723	20.300	30.023	-20.155	50.178	AVERAGE
5		0.908	9.810	14.350	24.160	-31.840	56.000	QUASPEAK
6		0.908	9.810	8.460	18.270	-27.730	46.000	AVERAGE
7		2.748	9.833	19.410	29.243	-26.757	56.000	QUASPEAK
8		2.748	9.833	13.990	23.823	-22.177	46.000	AVERAGE
9		10.396	10.114	13.460	23.574	-36.426	60.000	QUASPEAK
10		10.396	10.114	5.930	16.044	-33.956	50.000	AVERAGE
11		16.384	10.253	18.830	29.083	-30.917	60.000	QUASPEAK
12		16.384	10.253	18.450	28.703	-21.297	50.000	AVERAGE

**Note:**

1. All Reading Levels are Quasi-Peak and average value.
2. " \* ", means this data is the worst emission level.
3. Measurement Level = Reading Level + Correct Factor.



**3. Peak Power Output**

**3.1. Test Equipment**

The following test equipments are used during the test:

Item	Equipment	Manufacturer	Model No. / Serial No.	Last Cal.
1	Spectrum Analyzer	R&S	FSP/ 100005	Oct., 2008
2	No.1 OATS			Sep., 2008

Note: All equipment upon which need to calibrated are with calibration period of 1 year.

**3.2. Test Setup**

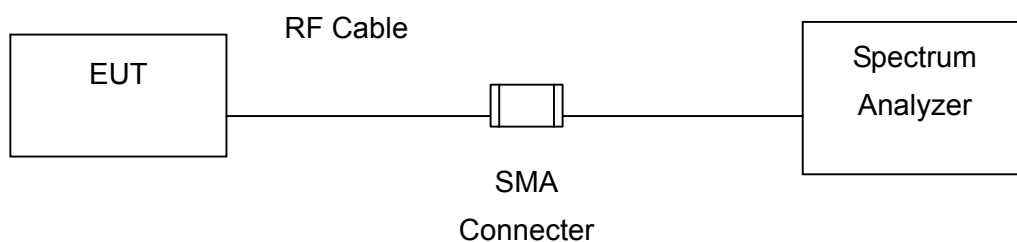

**3.3. Test procedures**

The EUT was setup according to ANSI C63.4, 2003 and tested according to FHSS test procedure of FCC Public Notice DA 00-705 for compliance to FCC 47CFR 15.247 requirements

**3.4. Limits**

For frequency hopping systems operating in the 902-928 MHz band: 1 Watt for systems employing at least 50 hopping channels; and, 0.25 Watts for systems employing less than 50 hopping channels.

For frequency hopping systems in the 2400-2483.5 MHz band employing at least 75 hopping channels, and all frequency hopping systems in the 5725-5850 MHz band: 1Watt. For all other frequency hopping systems in the 2400-2483.5 MHz band: 0.125 Watt.

**3.5. Test Specification**

According to FCC Part 15 Subpart C Paragraph 15.247: 2008

### 3.6. Test Result

Product	Conference Phone		
Test Item	Peak Power Output		
Test Mode	Transmit		
Date of Test	2008/12/23	Test Site	No.1 OATS

Channel No.	Frequency (MHz)	Measure Level (dBm)	Limit (dBm)	Result
00	2402.00	0.38	1Watt= 30 dBm	Pass

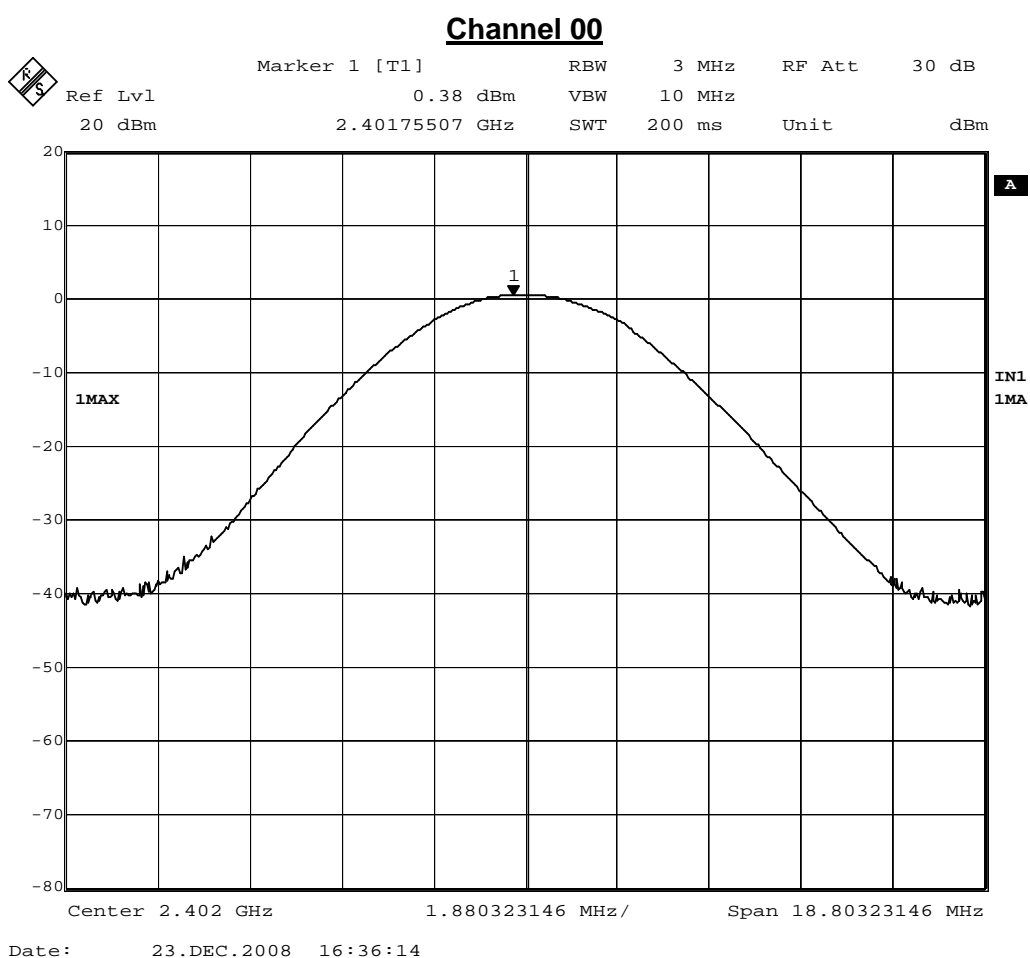

Product	Conference Phone		
Test Item	Peak Power Output		
Test Mode	Transmit		
Date of Test	2008/12/23	Test Site	No.1 OATS

Channel No.	Frequency (MHz)	Measure Level (dBm)	Limit (dBm)	Result
39	2441.00	1.14	1Watt= 30 dBm	Pass

### Channel 39

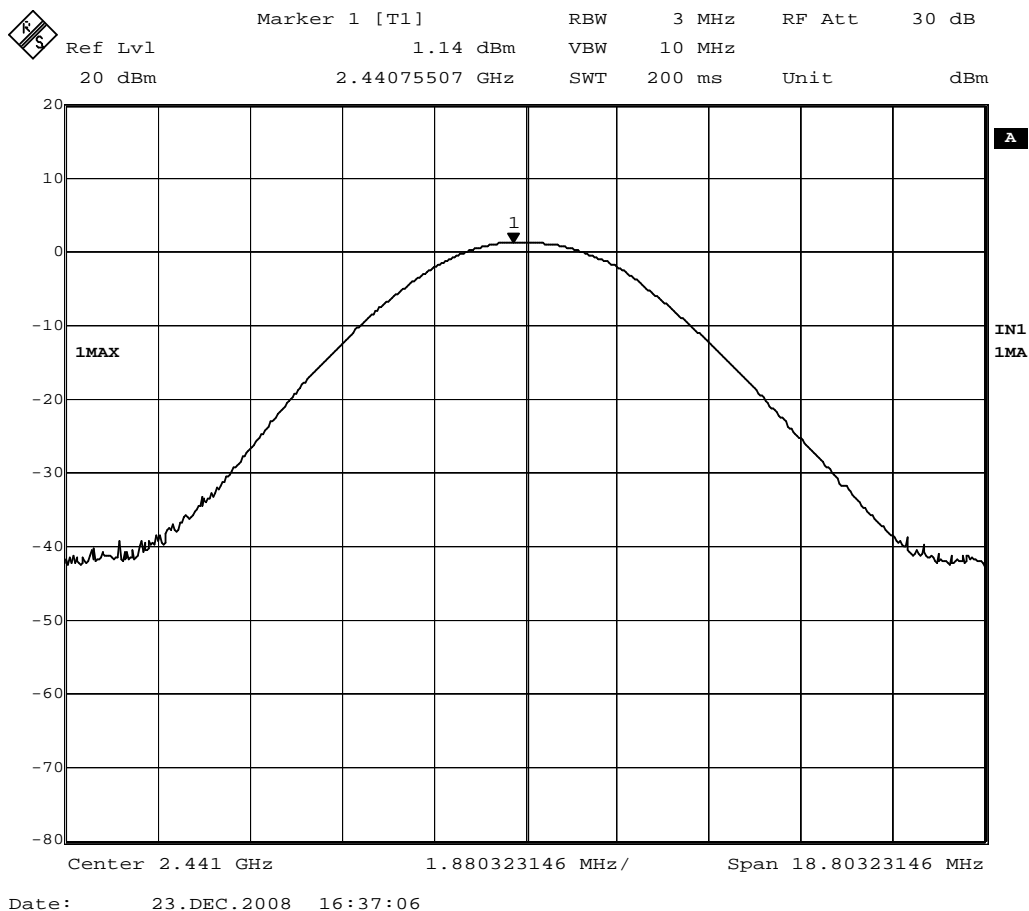

Product	Conference Phone		
Test Item	Peak Power Output		
Test Mode	Transmit		
Date of Test	2008/12/23	Test Site	No.1 OATS

Channel No.	Frequency (MHz)	Measure Level (dBm)	Limit (dBm)	Result
78	2480.00	0.00	1Watt= 30 dBm	Pass

### Channel 78

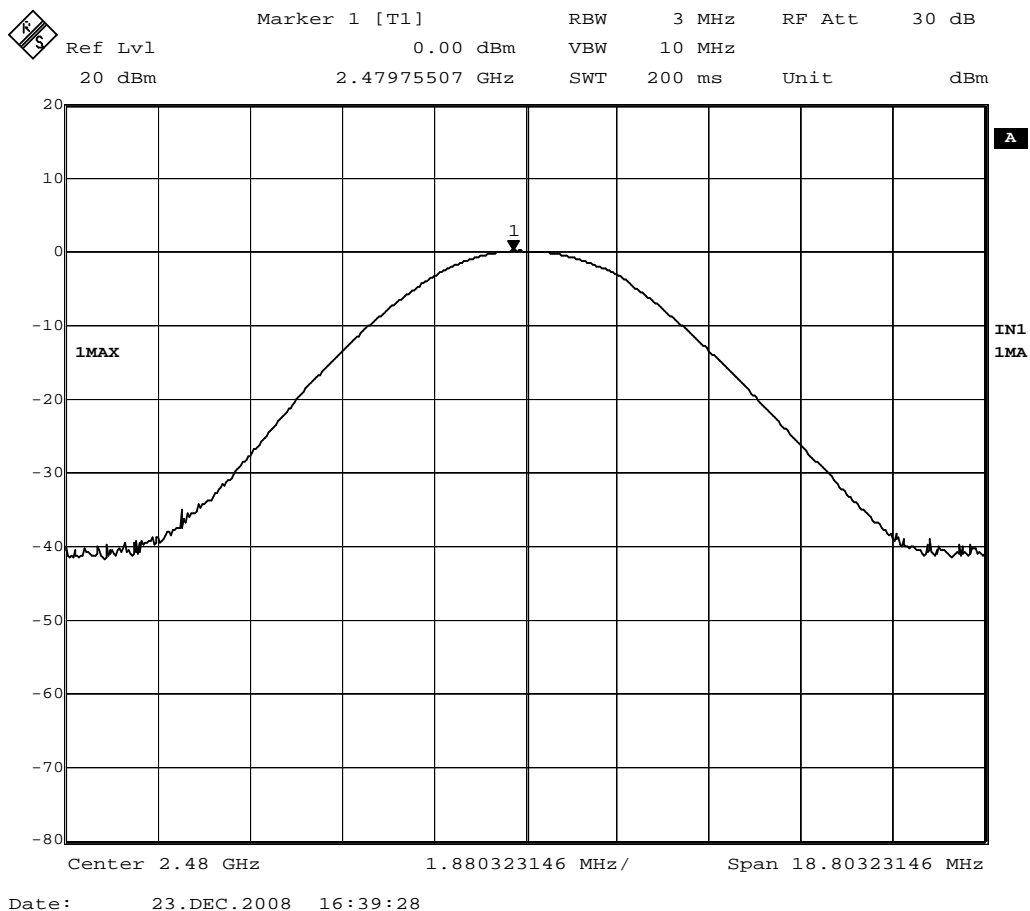

4. Radiated Emission

4.1. Test Equipment

The following test equipment are used during the test:

Radiated Emission / Site3

Instrument	Manufacturer	Type No.	Serial No	Cal. Date
Bilog Antenna	Schaffner Chase	CBL6112B	2673	2008/09/03
Horn Antenna	Electro Metrics	EM-6961	103325	2008/03/15
Pre-Amplifier	HP	8449B	3008A01123	2008/11/15
Pre-Amplifier	Quietek	AP-025C	003	N/A
Spectrum Analyzer	R & S	FSP40	100005	2008/08/25
Spectrum Analyzer	Advantest	R3162	91700283	2008/11/01
Test Receiver	R & S	ESCS 30	836858/022	2008/02/18

- Note: 1. All equipments that need to calibrate are with calibration period of 1 year.  
 2. "N/A" Ca1.Date is used to Pre-test, not final test.

4.2. Test Setup

Under 1GHz Test Setup:

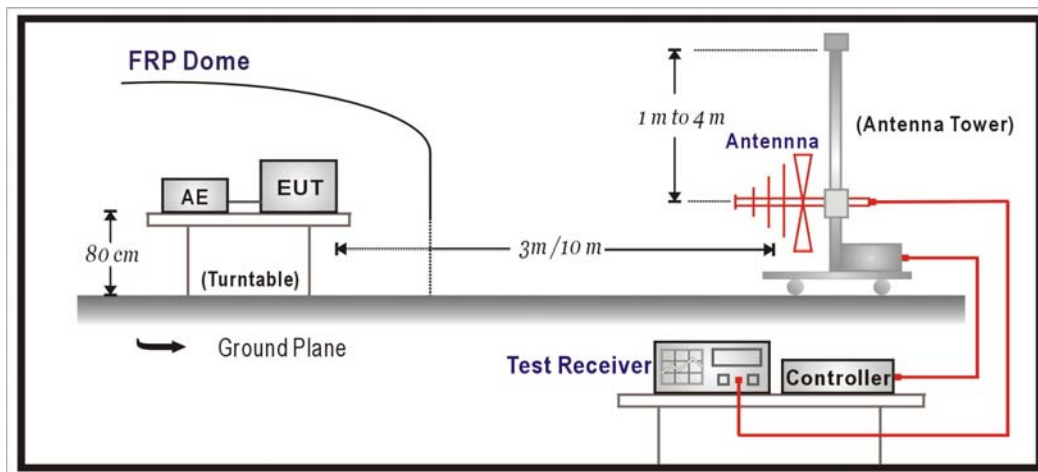

Above 1GHz Test Setup:

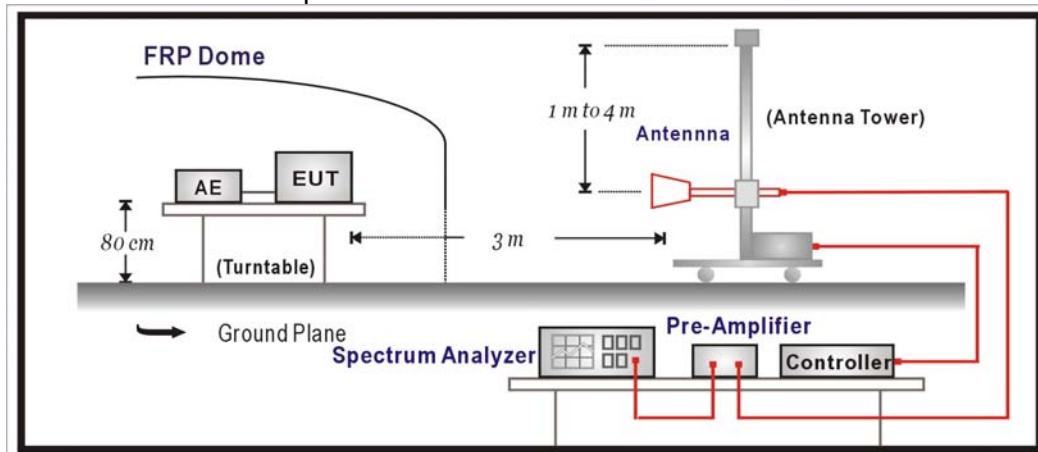

**4.3. Limits**

Emissions radiated outside of the specified frequency bands, except for harmonics, shall be attenuated by at least 20dB below the level of the fundamental or to the general radiated emission limits in paragraph 15.209, whichever is the lesser attenuation.

<b>FCC Part 15 Subpart C Paragraph 15.209 Limits</b>		
Frequency MHz	uV/m	dBuV/m
30-88	100	40
88-216	150	43.5
216-960	200	46
Above 960	500	54

- Remarks :
1. RF Voltage (dBuV) = 20 log RF Voltage (uV)
  2. In the Above Table, the tighter limit applies at the band edges.
  3. Distance refers to the distance in meters between the measuring instrument antenna and the closed point of any part of the device or system.

**4.4. Test Procedure**

The EUT and its simulators are placed on a turn table which is 0.8 meter above ground. The turn table can rotate 360 degrees to determine the position of the maximum emission level. The antenna can move up and down between 1 meter and 4 meters to find out the maximum emission level.

Both horizontal and vertical polarization of the antenna are set on measurement. In order to find the maximum emission, all of the interface cables must be manipulated according to ANSI C63.4:2003 on radiated measurement.

On any frequency or frequencies below or equal to 1000 MHz, the limits shown are based on measuring equipment employing a quasi-peak detector function and on any frequency or frequencies above 1000 MHz the radiated limits shown are based upon the use of measurement instrumentation employing an average detector function. When average radiated emission measurement are included emission measurement below 1000 MHz, there also is a limit on the radio frequency emissions, as measured using instrumentation with a peak detector function, corresponding to 20 dB above the maximum permitted average limit. The bandwidth below 1GHz setting on the field strength meter is 120 kHz and above 1GHz is 1MHz.

**4.5. Test Specification**

According to FCC Part 15 Subpart C Paragraph 15.247: 2008

4.6. Test Result

30MHz-1GHz Spurious:

Site : Site 3	Time : 2009/01/10 - 17:51
Limit : FCC_CLASS_B_03M_QP	Margin : 6
Probe : FCC_30-1G(2008-9) - HORIZONTAL	Power : AC 120V/60Hz
EUT : Conference Phone	Note : TX

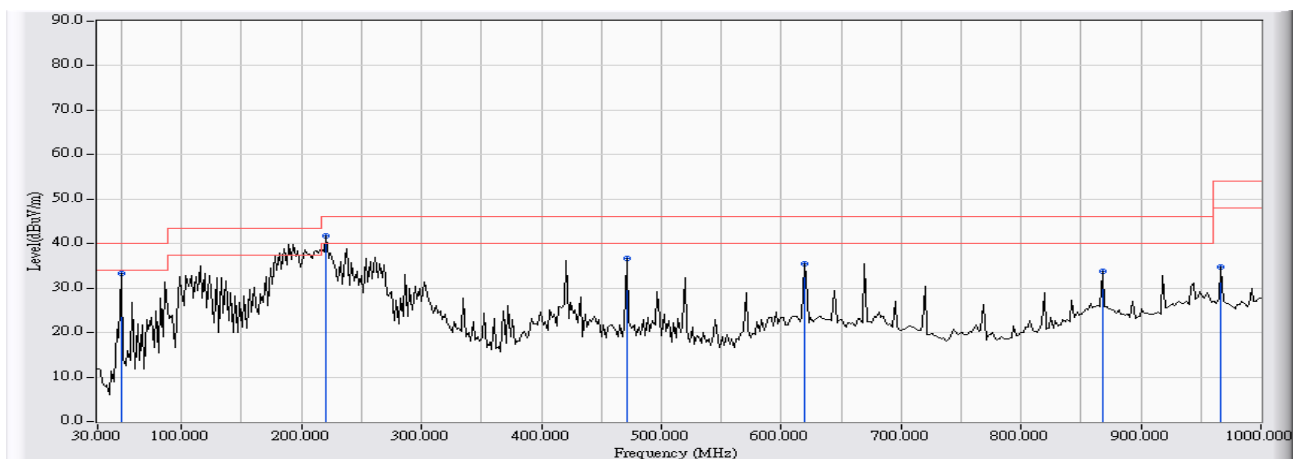

	Frequency (MHz)	Correct Factor (dB)	Reading Level (dBuV)	Measure Level (dBuV/m)	Margin (dB)	Limit (dBuV/m)	Detector Type
1	49.439	-13.700	46.953	33.253	-6.747	40.000	QUASPEAK
2	* 220.501	-13.141	54.924	41.783	-4.217	46.000	QUASPEAK
3	471.263	-6.602	43.226	36.624	-9.376	46.000	QUASPEAK
4	618.998	-2.217	37.566	35.349	-10.651	46.000	QUASPEAK
5	867.816	0.508	33.322	33.829	-12.171	46.000	QUASPEAK
6	966.954	2.550	32.237	34.787	-19.213	54.000	QUASPEAK

Note:

1. All Reading Levels are Quasi-Peak value.
2. “ \* ”, means this data is the worst emission level.
3. Measurement Level = Reading Level + Correct Factor.

Site : Site 3	Time : 2009/01/10 - 17:54
Limit : FCC_CLASS_B_03M_QP	Margin : 6
Probe : FCC_30-1G(2008-9) - VERTICAL	Power : AC 120V/60Hz
EUT : Conference Phone	Note : TX

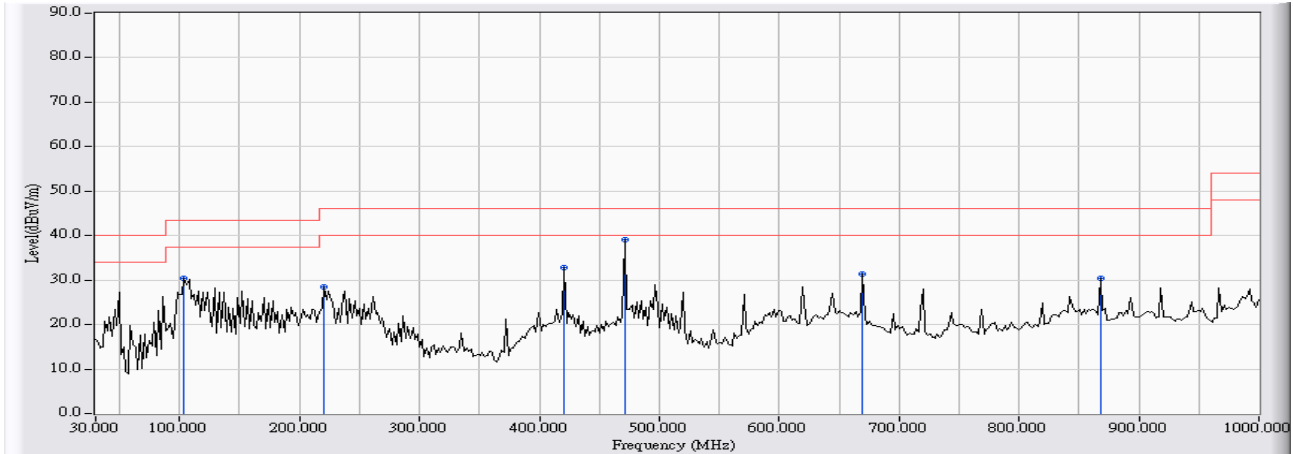

	Frequency (MHz)	Correct Factor (dB)	Reading Level (dBuV)	Measure Level (dBuV/m)	Margin (dB)	Limit (dBuV/m)	Detector Type
1	103.868	-11.720	42.095	30.374	-13.126	43.500	QUASPEAK
2	220.501	-14.472	42.902	28.431	-17.569	46.000	QUASPEAK
3	420.721	-4.413	37.190	32.777	-13.223	46.000	QUASPEAK
4	* 471.263	-3.969	43.120	39.152	-6.848	46.000	QUASPEAK
5	669.539	-2.593	33.931	31.338	-14.662	46.000	QUASPEAK
6	867.816	-2.288	32.593	30.305	-15.695	46.000	QUASPEAK

**Note:**

1. All Reading Levels are Quasi-Peak value.
2. “ \* ”, means this data is the worst emission level.
3. Measurement Level = Reading Level + Correct Factor.



**Harmonic & Spurious:**

Site : Site 3	Time : 2009/01/10 - 15:11
Limit : FCC_SpartC_15.247_H_03M_PK	Margin : 6
Probe : FCC_1-18G(2009-01) - HORIZONTAL	Power : AC 120V/60Hz
EUT : Conference Phone	Note : TX-2402MHz

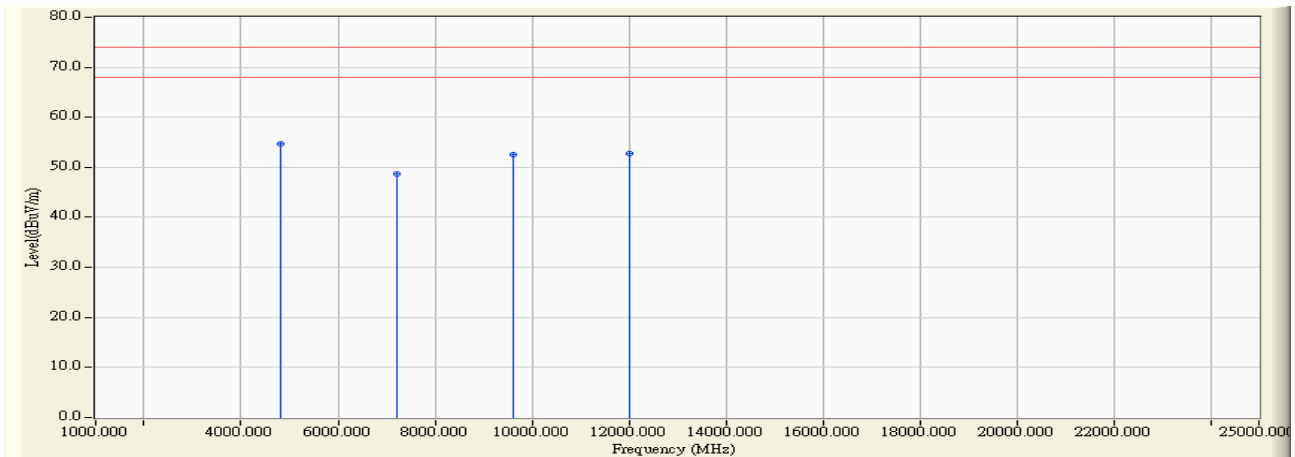

	Frequency (MHz)	Correct Factor (dB)	Reading Level (dBuV)	Measure Level (dBuV/m)	Margin (dB)	Peak Limit (dBuV/m)	Average Limit (dBuV/m)	Detector Type
1	4804.040	3.345	51.380	54.725	-19.275	74.000	54.00	PEAK
2	7206.040	9.742	39.030	48.772	-25.228	74.000	54.00	PEAK
3	9608.040	13.653	38.920	52.573	-21.427	74.000	54.00	PEAK
4	* 12010.040	18.807	33.870	52.677	-21.323	74.000	54.00	PEAK

**Note:**

1. All readings above 1GHz are performed with peak and/or average measurements as necessary.
2. Peak measurements: RBW = 1MHz, VBW = 3 MHz, Sweep: Auto.
3. Average measurements: RBW = 1MHz, VBW = 10 Hz, Sweep: Auto.
4. “ \* ”, means this data is the worst emission level.
5. Measurement Level = Reading Level + Correct Factor.
6. The average measurement was not performed when the peak measured data under the limit of average detection.
7. The Emission above 13GHz were not included is because their levels are too low.

Site : Site 3	Time : 2009/01/10 - 15:22
Limit : FCC_SpartC_15.247_H_03M_AV	Margin : 6
Probe : FCC_1-18G(2009-01) - HORIZONTAL	Power : AC 120V/60Hz
EUT : Conference Phone	Note : TX-2402MHz

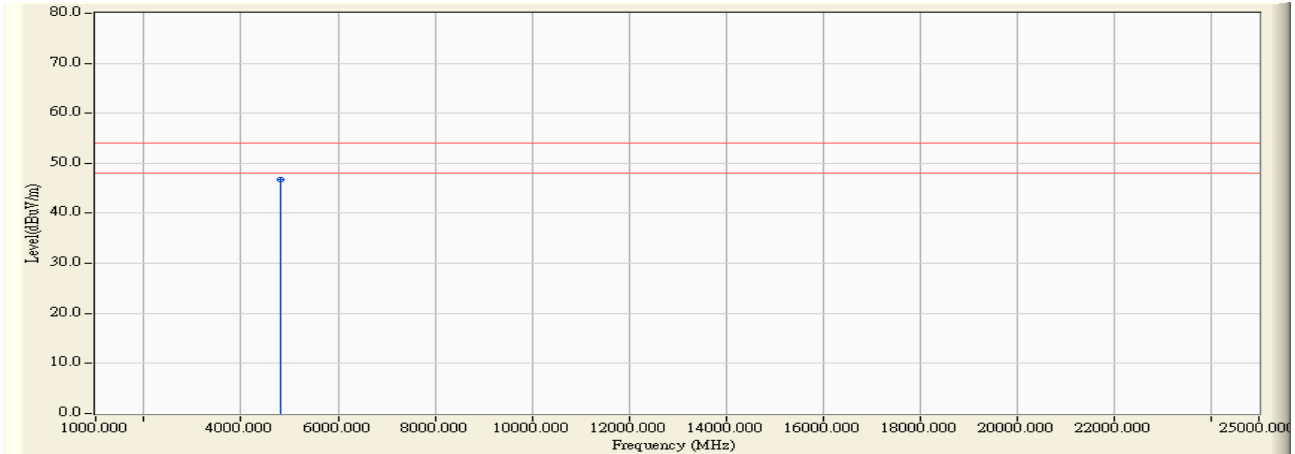

		Frequency (MHz)	Correct Factor (dB)	Reading Level (dBuV)	Measure Level (dBuV/m)	Margin (dB)	Peak Limit (dBuV/m)	Average Limit (dBuV/m)	Detector Type
1	*	4804.020	3.345	43.340	46.685	-7.315	74.000	54.00	AVERAGE

**Note:**

1. All readings above 1GHz are performed with peak and/or average measurements as necessary.
2. Peak measurements: RBW = 1MHz, VBW = 3 MHz, Sweep: Auto.
3. Average measurements: RBW = 1MHz, VBW = 10 Hz, Sweep: Auto.
4. “ \* ”, means this data is the worst emission level.
5. Measurement Level = Reading Level + Correct Factor.
6. The average measurement was not performed when the peak measured data under the limit of average detection.
7. The Emission above 13GHz were not included is because their levels are too low.

Site : Site 3	Time : 2009/01/10 - 15:40
Limit : FCC_SpartC_15.247_H_03M_PK	Margin : 6
Probe : FCC_1-18G(2009-01) - VERTICAL	Power : AC 120V/60Hz
EUT : Conference Phone	Note : TX-2402MHz

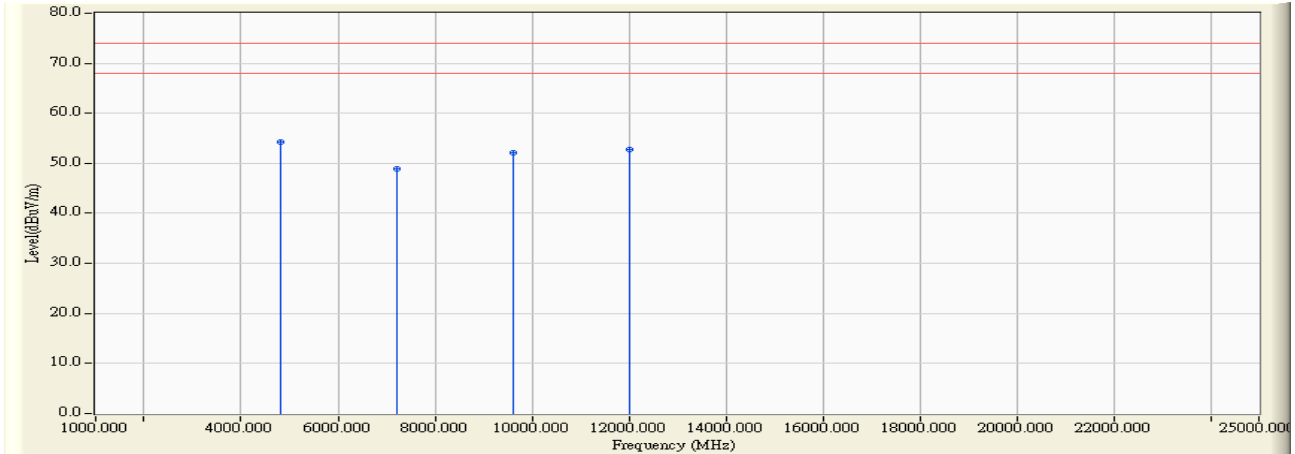

		Frequency (MHz)	Correct Factor (dB)	Reading Level (dBuV)	Measure Level (dBuV/m)	Margin (dB)	Peak Limit (dBuV/m)	Average Limit (dBuV/m)	Detector Type
1	*	4804.040	5.534	48.730	54.264	-19.736	74.000	54.00	PEAK
2		7206.040	9.397	39.610	49.007	-24.993	74.000	54.00	PEAK
3		9608.040	13.716	38.460	52.176	-21.824	74.000	54.00	PEAK
4		12010.040	17.436	35.400	52.837	-21.163	74.000	54.00	PEAK

**Note:**

1. All readings above 1GHz are performed with peak and/or average measurements as necessary.
2. Peak measurements: RBW = 1MHz, VBW = 3 MHz, Sweep: Auto.
3. Average measurements: RBW = 1MHz, VBW = 10 Hz, Sweep: Auto.
4. “ \* ”, means this data is the worst emission level.
5. Measurement Level = Reading Level + Correct Factor.
6. The average measurement was not performed when the peak measured data under the limit of average detection.
7. The Emission above 13GHz were not included is because their levels are too low.

Site : Site 3	Time : 2009/01/10 - 15:44
Limit : FCC_SpartC_15.247_H_03M_AV	Margin : 6
Probe : FCC_1-18G(2009-01) - VERTICAL	Power : AC 120V/60Hz
EUT : Conference Phone	Note : TX-2402MHz

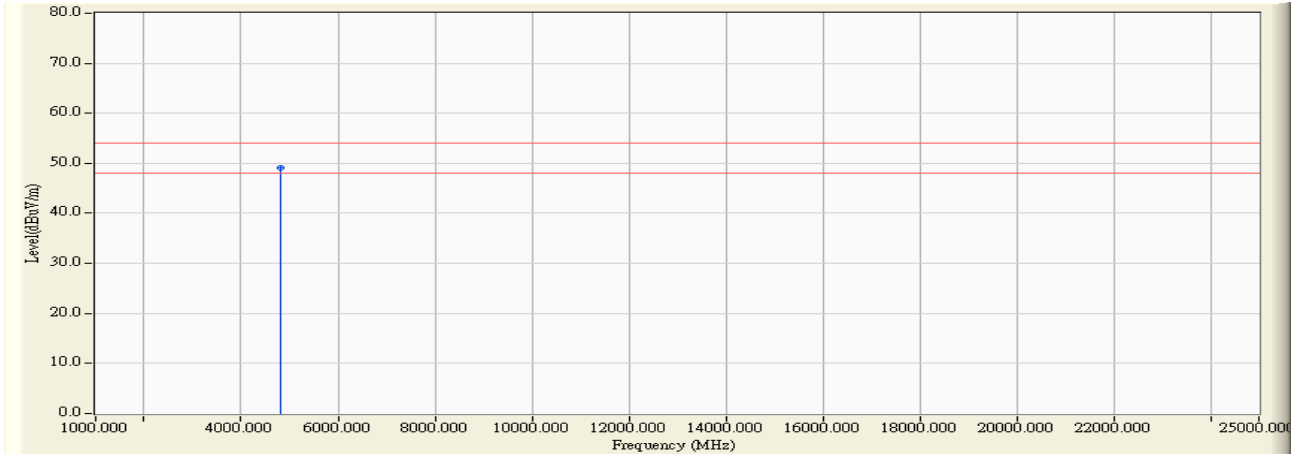

		Frequency (MHz)	Correct Factor (dB)	Reading Level (dBuV)	Measure Level (dBuV/m)	Margin (dB)	Peak Limit (dBuV/m)	Average Limit (dBuV/m)	Detector Type
1	*	4804.000	5.534	43.570	49.104	-4.896	74.000	54.00	AVERAGE

**Note:**

1. All readings above 1GHz are performed with peak and/or average measurements as necessary.
2. Peak measurements: RBW = 1MHz, VBW = 3 MHz, Sweep: Auto.
3. Average measurements: RBW = 1MHz, VBW = 10 Hz, Sweep: Auto.
4. “ \* ”, means this data is the worst emission level.
5. Measurement Level = Reading Level + Correct Factor.
6. The average measurement was not performed when the peak measured data under the limit of average detection.
7. The Emission above 13GHz were not included is because their levels are too low.

Site : Site 3	Time : 2009/01/10 - 16:00
Limit : FCC_SpartC_15.247_H_03M_PK	Margin : 6
Probe : FCC_1-18G(2009-01) - HORIZONTAL	Power : AC 120V/60Hz
EUT : Conference Phone	Note : TX-2441MHz

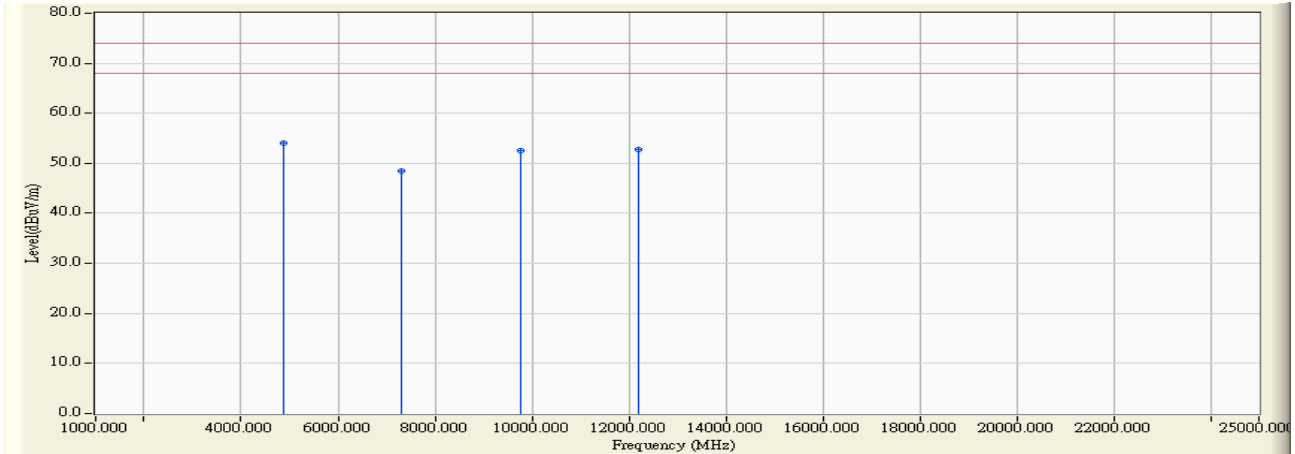

		Frequency (MHz)	Correct Factor (dB)	Reading Level (dBuV)	Measure Level (dBuV/m)	Margin (dB)	Peak Limit (dBuV/m)	Average Limit (dBuV/m)	Detector Type
1	*	4881.960	3.553	50.400	53.953	-20.047	74.000	54.00	PEAK
2		7322.960	10.281	38.250	48.532	-25.468	74.000	54.00	PEAK
3		9764.010	14.282	38.260	52.542	-21.458	74.000	54.00	PEAK
4		12204.920	18.043	34.630	52.673	-21.327	74.000	54.00	PEAK

**Note:**

1. All readings above 1GHz are performed with peak and/or average measurements as necessary.
2. Peak measurements: RBW = 1MHz, VBW = 3 MHz, Sweep: Auto.
3. Average measurements: RBW = 1MHz, VBW = 10 Hz, Sweep: Auto.
4. “ \* ”, means this data is the worst emission level.
5. Measurement Level = Reading Level + Correct Factor.
6. The average measurement was not performed when the peak measured data under the limit of average detection.
7. The Emission above 13GHz were not included is because their levels are too low.

Site : Site 3	Time : 2009/01/10 - 16:04
Limit : SpartC_15.247_H_03M_AV	Margin : 6
Probe : FCC_1-18G(2009-01) -- HORIZONTAL	Power : AC 120V/60Hz
EUT : Conference Phone	Note : TX-2441MHz

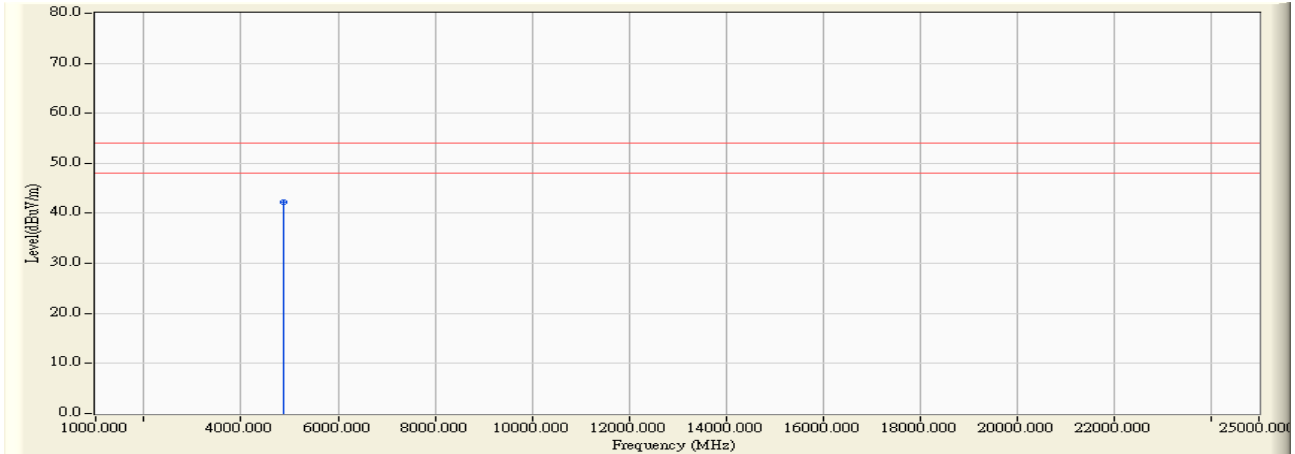

		Frequency (MHz)	Correct Factor (dB)	Reading Level (dBuV)	Measure Level (dBuV/m)	Margin (dB)	Peak Limit (dBuV/m)	Average Limit (dBuV/m)	Detector Type
1	*	4882.000	3.553	38.630	42.183	-11.817	74.000	54.00	AVERAGE

**Note:**

1. All readings above 1GHz are performed with peak and/or average measurements as necessary.
2. Peak measurements: RBW = 1MHz, VBW = 3 MHz, Sweep: Auto.
3. Average measurements: RBW = 1MHz, VBW = 10 Hz, Sweep: Auto.
4. “ \* ”, means this data is the worst emission level.
5. Measurement Level = Reading Level + Correct Factor.
6. The average measurement was not performed when the peak measured data under the limit of average detection.
7. The Emission above 13GHz were not included is because their levels are too low.

Site : Site 3	Time : 2009/01/10 - 16:08
Limit : FCC_SpartC_15.247_H_03M_PK	Margin : 6
Probe : FCC_1-18G(2009-01) - VERTICAL	Power : AC 120V/60Hz
EUT : Conference Phone	Note : TX-2441MHz

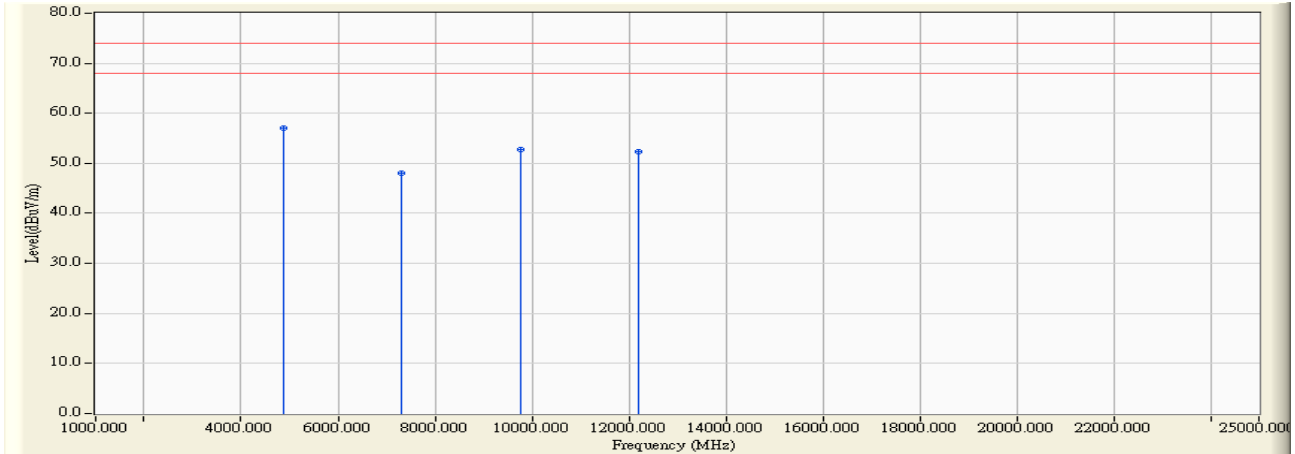

		Frequency (MHz)	Correct Factor (dB)	Reading Level (dBuV)	Measure Level (dBuV/m)	Margin (dB)	Peak Limit (dBuV/m)	Average Limit (dBuV/m)	Detector Type
1	*	4881.880	5.580	51.540	57.121	-16.879	74.000	54.000	PEAK
2		7322.950	9.626	38.320	47.947	-26.053	74.000	54.000	PEAK
3		9764.010	14.497	38.300	52.797	-21.203	74.000	54.000	PEAK
4		12204.940	17.086	35.200	52.287	-21.713	74.000	54.000	PEAK

**Note:**

1. All readings above 1GHz are performed with peak and/or average measurements as necessary.
2. Peak measurements: RBW = 1MHz, VBW = 3 MHz, Sweep: Auto.
3. Average measurements: RBW = 1MHz, VBW = 10 Hz, Sweep: Auto.
4. “ \* ”, means this data is the worst emission level.
5. Measurement Level = Reading Level + Correct Factor.
6. The average measurement was not performed when the peak measured data under the limit of average detection.
7. The Emission above 13GHz were not included is because their levels are too low.

Site : Site 3	Time : 2009/01/10 - 16:08
Limit : FCC_SpartC_15.247_H_03M_AV	Margin : 6
Probe : FCC_1-18G(2009-01) - VERTICAL	Power : AC 120V/60Hz
EUT : Conference Phone	Note : TX-2441MHz

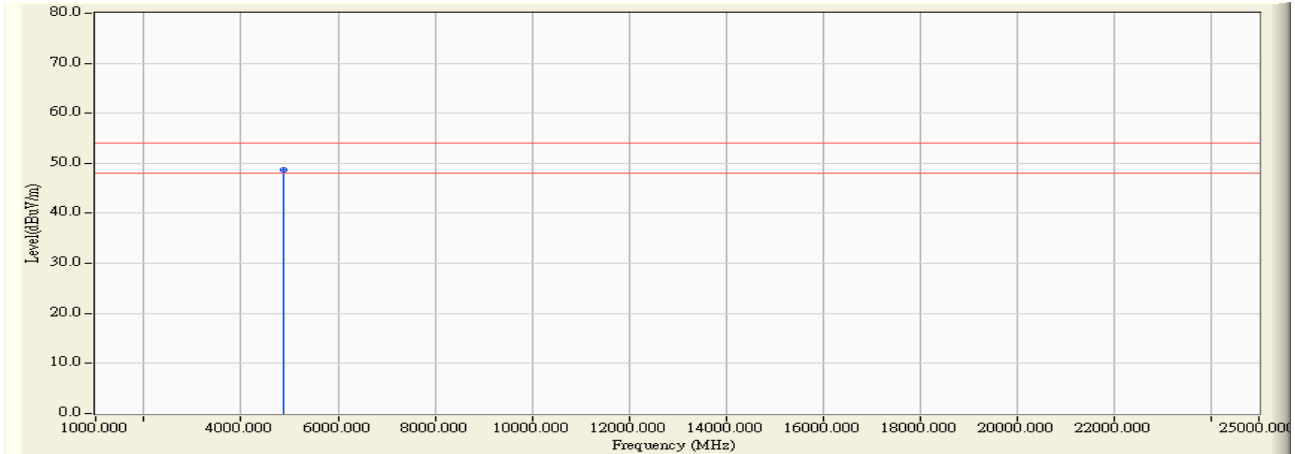

		Frequency (MHz)	Correct Factor (dB)	Reading Level (dBuV)	Measure Level (dBuV/m)	Margin (dB)	Peak Limit (dBuV/m)	Average Limit (dBuV/m)	Detector Type
1	*	4882.040	5.581	43.020	48.601	-5.399	74.000	54.00	AVERAGE

**Note:**

1. All readings above 1GHz are performed with peak and/or average measurements as necessary.
2. Peak measurements: RBW = 1MHz, VBW = 3 MHz, Sweep: Auto.
3. Average measurements: RBW = 1MHz, VBW = 10 Hz, Sweep: Auto.
4. “ \* ”, means this data is the worst emission level.
5. Measurement Level = Reading Level + Correct Factor.
6. The average measurement was not performed when the peak measured data under the limit of average detection.
7. The Emission above 13GHz were not included is because their levels are too low.



Site : Site 3	Time : 2009/01/10 - 16:33
Limit : FCC_SpartC_15.247_H_03M_PK	Margin : 6
Probe : FCC_1-18G(2009-01) - HORIZONTAL	Power : AC 120V/60Hz
EUT : Conference Phone	Note : TX-2480MHz

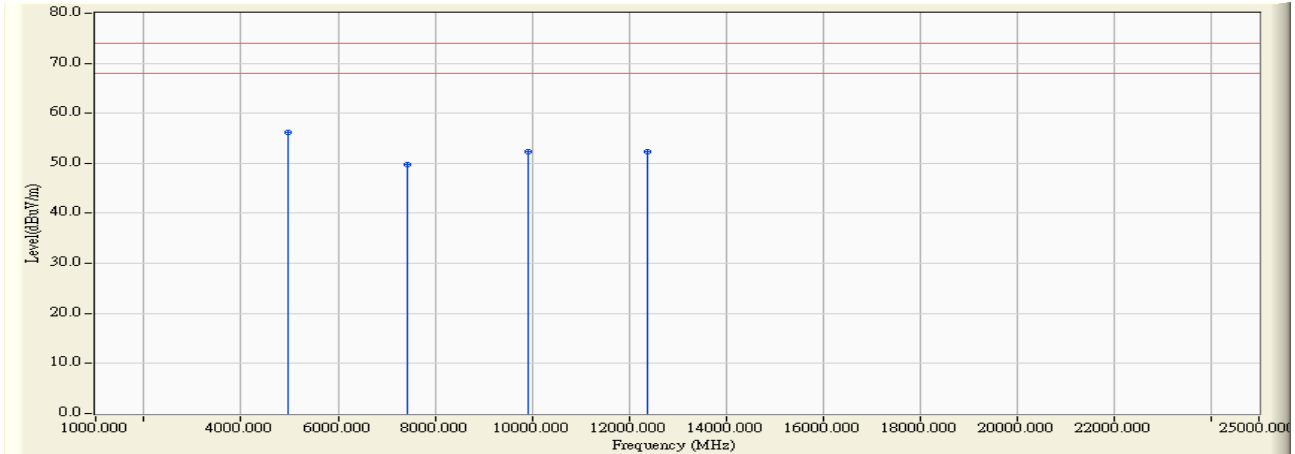

		Frequency (MHz)	Correct Factor (dB)	Reading Level (dBuV)	Measure Level (dBuV/m)	Margin (dB)	Peak Limit (dBuV/m)	Average Limit (dBuV/m)	Detector Type
1	*	4960.000	3.775	52.520	56.295	-17.705	74.000	54.00	PEAK
2		7440.040	10.832	38.960	49.792	-24.208	74.000	54.00	PEAK
3		9920.040	14.908	37.320	52.228	-21.772	74.000	54.00	PEAK
4		12399.960	17.270	35.010	52.280	-21.720	74.000	54.00	PEAK

**Note:**

1. All readings above 1GHz are performed with peak and/or average measurements as necessary.
2. Peak measurements: RBW = 1MHz, VBW = 3 MHz, Sweep: Auto.
3. Average measurements: RBW = 1MHz, VBW = 10 Hz, Sweep: Auto.
4. “ \* ”, means this data is the worst emission level.
5. Measurement Level = Reading Level + Correct Factor.
6. The average measurement was not performed when the peak measured data under the limit of average detection.
7. The Emission above 13GHz were not included is because their levels are too low.

Site : Site 3	Time : 2009/01/10 - 16:46
Limit : FCC_SpartC_15.247_H_03M_AV	Margin : 6
Probe : FCC_1-18G(2009-01) - HORIZONTAL	Power : AC 120V/60Hz
EUT : Conference Phone	Note : TX-2480MHz

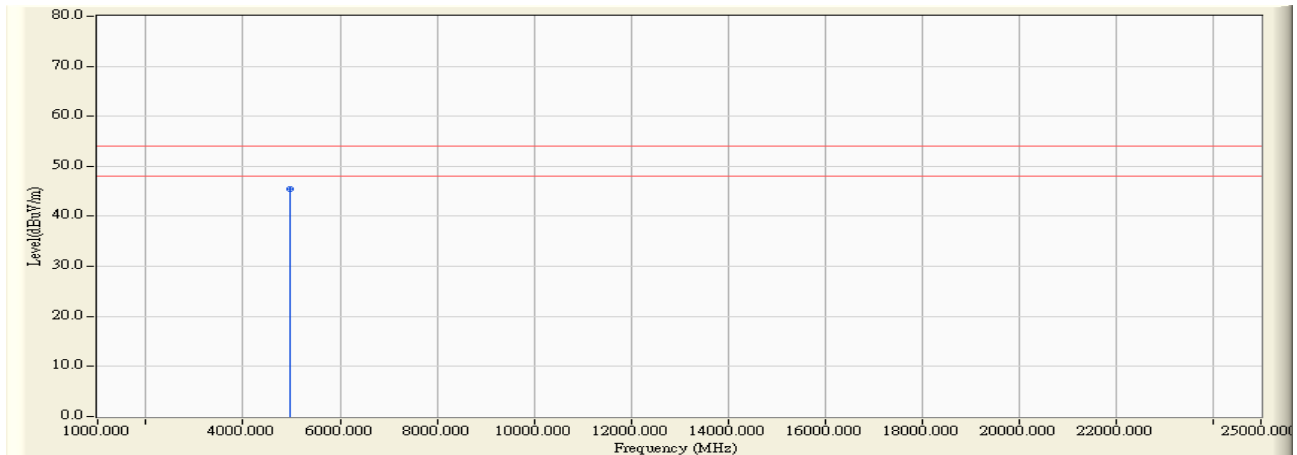

		Frequency (MHz)	Correct Factor (dB)	Reading Level (dBuV)	Measure Level (dBuV/m)	Margin (dB)	Peak Limit (dBuV/m)	Average Limit (dBuV/m)	Detector Type
1	*	4960.000	3.775	41.710	45.485	-8.515	74.000	54.00	AVERAGE

**Note:**

1. All readings above 1GHz are performed with peak and/or average measurements as necessary.
2. Peak measurements: RBW = 1MHz, VBW = 3 MHz, Sweep: Auto.
3. Average measurements: RBW = 1MHz, VBW = 10 Hz, Sweep: Auto.
4. “ \* ”, means this data is the worst emission level.
5. Measurement Level = Reading Level + Correct Factor.
6. The average measurement was not performed when the peak measured data under the limit of average detection.
7. The Emission above 13GHz were not included is because their levels are too low.

Site : Site 3	Time : 2009/01/10 - 16:57
Limit : FCC_SpartC_15.247_H_03M_PK	Margin : 6
Probe : FCC_1-18G(2009-01) - VERTICAL	Power : AC 120V/60Hz
EUT : Conference Phone	Note : TX-2480MHz

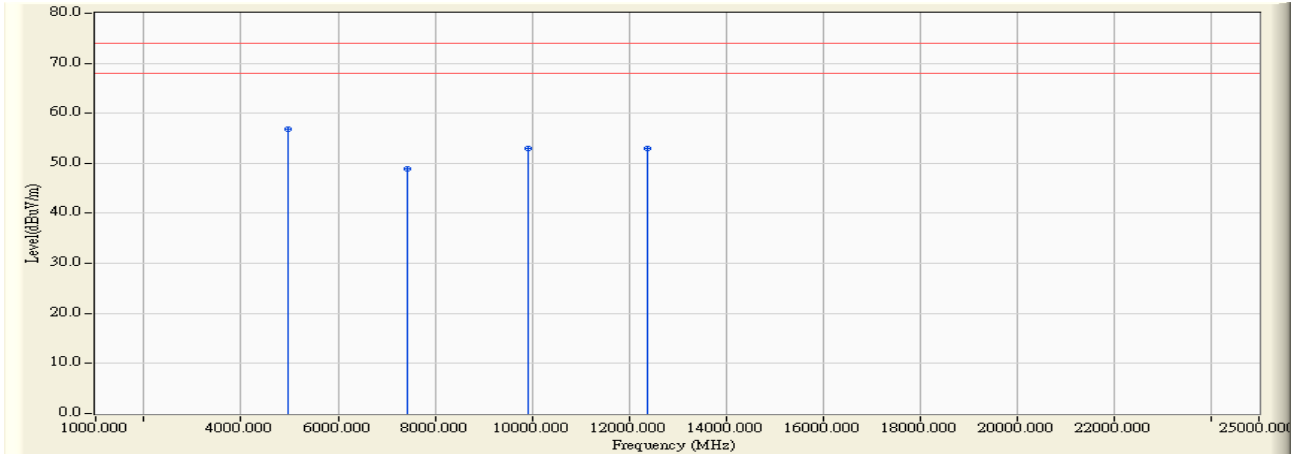

		Frequency (MHz)	Correct Factor (dB)	Reading Level (dBuV)	Measure Level (dBuV/m)	Margin (dB)	Peak Limit (dBuV/m)	Average Limit (dBuV/m)	Detector Type
1	*	4959.960	5.632	51.160	56.792	-17.208	74.000	54.00	PEAK
2		7440.050	9.868	39.090	48.958	-25.042	74.000	54.00	PEAK
3		9920.040	15.279	37.640	52.919	-21.081	74.000	54.00	PEAK
4		12399.960	16.724	36.240	52.964	-21.036	74.000	54.00	PEAK

**Note:**

1. All readings above 1GHz are performed with peak and/or average measurements as necessary.
2. Peak measurements: RBW = 1MHz, VBW = 3 MHz, Sweep: Auto.
3. Average measurements: RBW = 1MHz, VBW = 10 Hz, Sweep: Auto.
4. “ \* ”, means this data is the worst emission level.
5. Measurement Level = Reading Level + Correct Factor.
6. The average measurement was not performed when the peak measured data under the limit of average detection.
7. The Emission above 13GHz were not included is because their levels are too low.

Site : Site 3	Time : 2009/01/10 - 16:57
Limit : FCC_SpartC_15.247_H_03M_AV	Margin : 6
Probe : FCC_1-18G(2009-01) - VERTICAL	Power : AC 120V/60Hz
EUT : Conference Phone	Note : TX-2480MHz

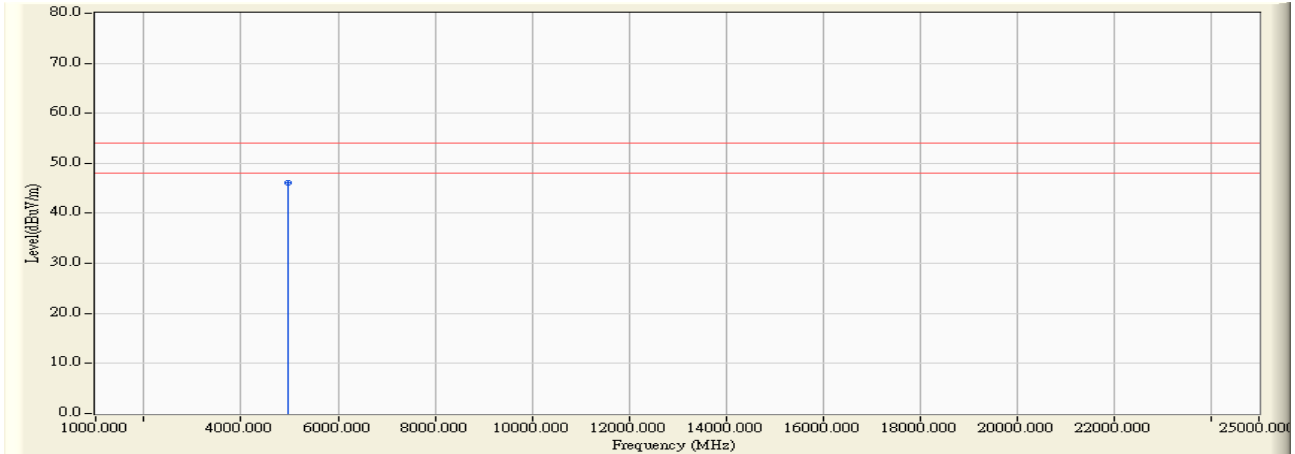

		Frequency (MHz)	Correct Factor (dB)	Reading Level (dBuV)	Measure Level (dBuV/m)	Margin (dB)	Peak Limit (dBuV/m)	Average Limit (dBuV/m)	Detector Type
1	*	4960.000	5.632	40.510	46.142	-7.858	74.000	54.00	AVERAGE

**Note:**

1. All readings above 1GHz are performed with peak and/or average measurements as necessary.
2. Peak measurements: RBW = 1MHz, VBW = 3 MHz, Sweep: Auto.
3. Average measurements: RBW = 1MHz, VBW = 10 Hz, Sweep: Auto.
4. “ \* ”, means this data is the worst emission level.
5. Measurement Level = Reading Level + Correct Factor.
6. The average measurement was not performed when the peak measured data under the limit of average detection.
7. The Emission above 13GHz were not included is because their levels are too low.

**5. RF antenna conducted test**

**5.1. Test Equipment**

The following test equipments are used during the test:

RF Conducted Measurement:				
Item	Equipment	Manufacturer	Model No. / Serial No.	Last Cal.
1	Spectrum Analyzer	R & S	FSP / 100561	Mar., 2008
2	No.1 OATS			Sep., 2008

- Note:
1. All equipments that need to calibrate are with calibration period of 1 year.
  2. Mark "X" test instruments are used to measure the final test results.

**5.2. Test Setup**

RF Conducted Measurement:

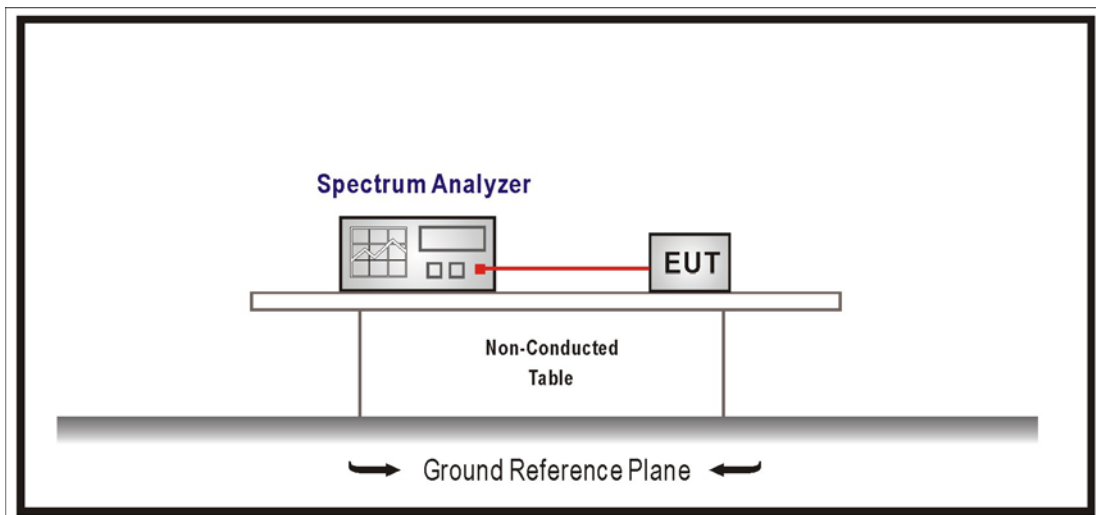

### **5.3. Limits**

In any 100 kHz bandwidth outside the frequency band in which the spread spectrum intentional radiator is operating, the radio frequency power that is produced by the intentional radiator shall be at least 20 dB below that in the 100 kHz bandwidth within the band that contains the highest level of the desired power, based on either an RF conducted or a radiated measurement. Attenuation below the general limits specified in Section 15.209(a) is not required. In addition, radiated emissions which fall in the restricted bands, as defined in Section 15.205(a), must also comply with the radiated emission limits specified in Section 15.209(a) (see Section 15.205(c)).

### **5.4. Test Procedure**

The EUT was setup according to ANSI C63.4, 2003 and tested according to FHSS test procedure of FCC Public Notice DA 00-705 for compliance to FCC 47CFR 15.247 requirements.

### **5.5. Test Specification**

According to FCC Part 15 Subpart C Paragraph 15.247: 2008

5.6. Test Result

Product	Conference Phone		
Test Item	RF antenna conducted test		
Test Mode	Mode 1: Transmit		
Date of Test	2008/12/23	Test Site	No.1 OATS

Channel No.	Frequency (MHz)	Measure Level (dBc)	Required Limit (dBc)	Result
00	2402	41.40	≥ 20	Pass

Figure Channel 00:

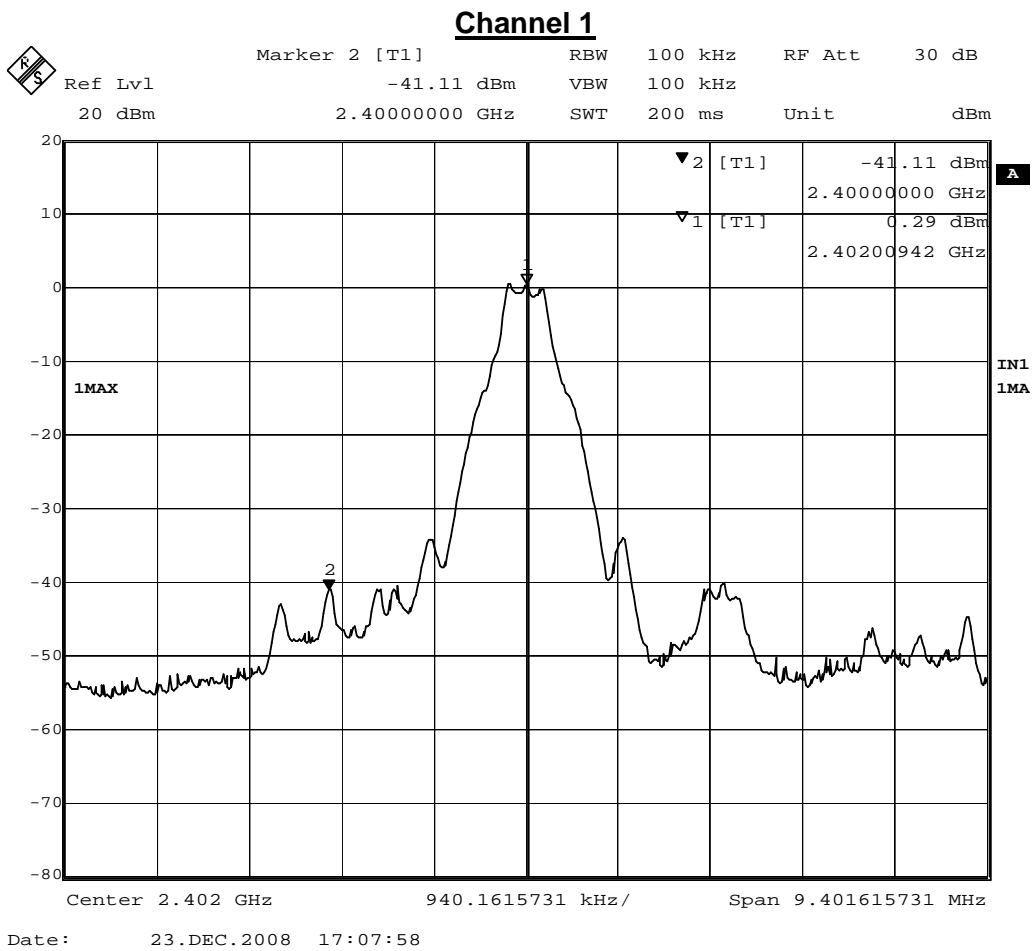

Product	Conference Phone		
Test Item	RF antenna conducted test		
Test Mode	Mode 1: Transmit		
Date of Test	2008/12/23	Test Site	No.1 OATS

Channel No.	Frequency (MHz)	Measure Level (dBc)	Required Limit (dBc)	Result
78	2480	50.23	$\geq 20$	Pass

Figure Channel 78:

### Channel 78

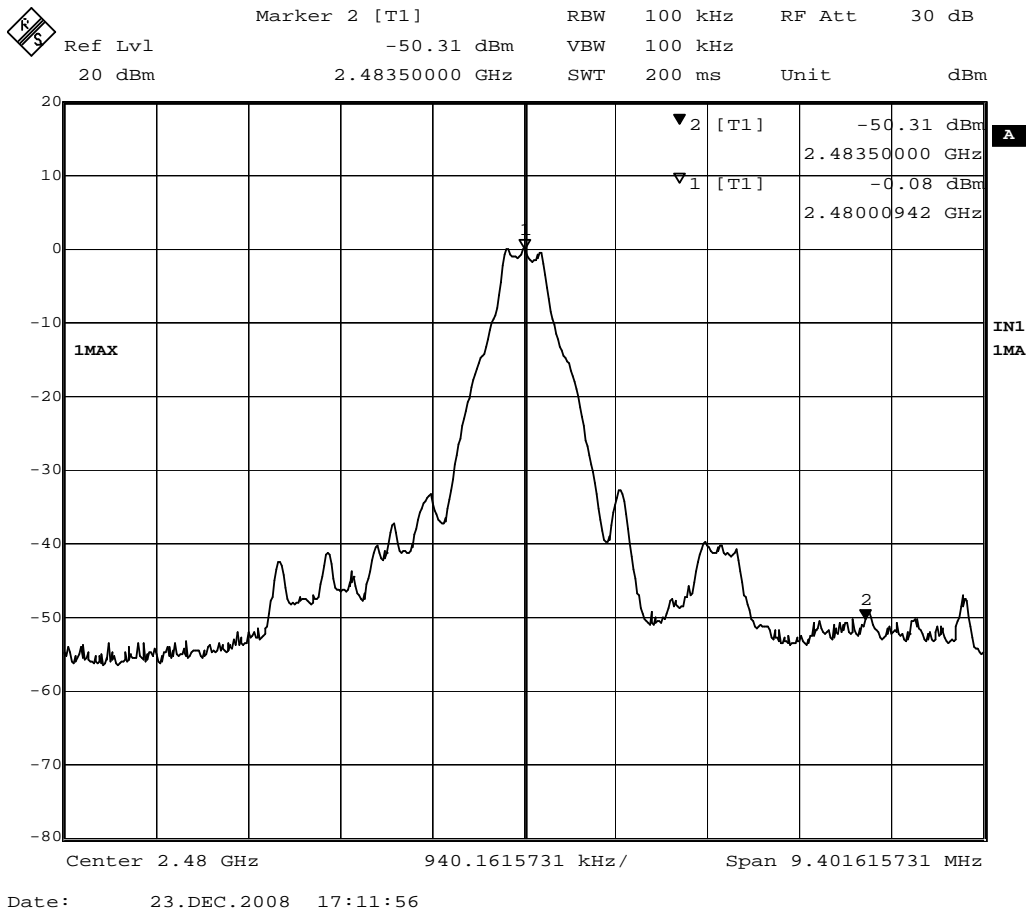



(1~2.4G)



Ref Lvl  
20 dBm

RBW 1 MHz RF Att 30 dB  
VBW 1 MHz  
SWT 200 ms Unit dBm

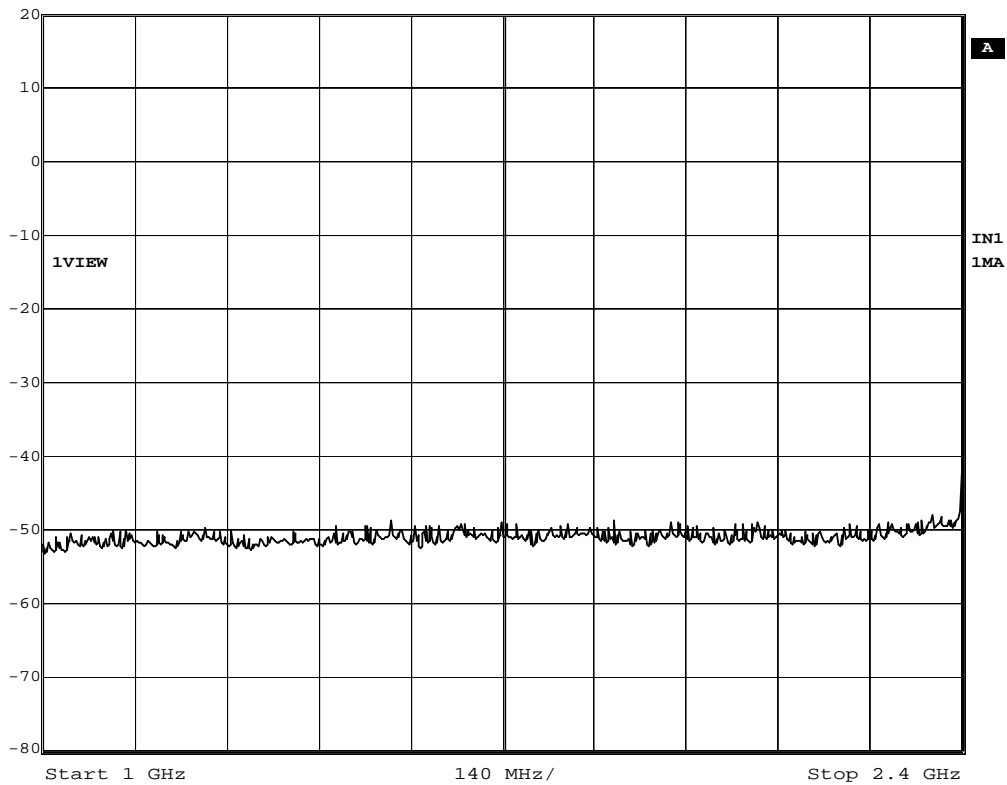

Date: 23.DEC.2008 17:32:19

(2.5-4.5G)



Ref Lvl  
20 dBm

RBW 1 MHz RF Att 30 dB  
VBW 1 MHz  
SWT 200 ms Unit dBm

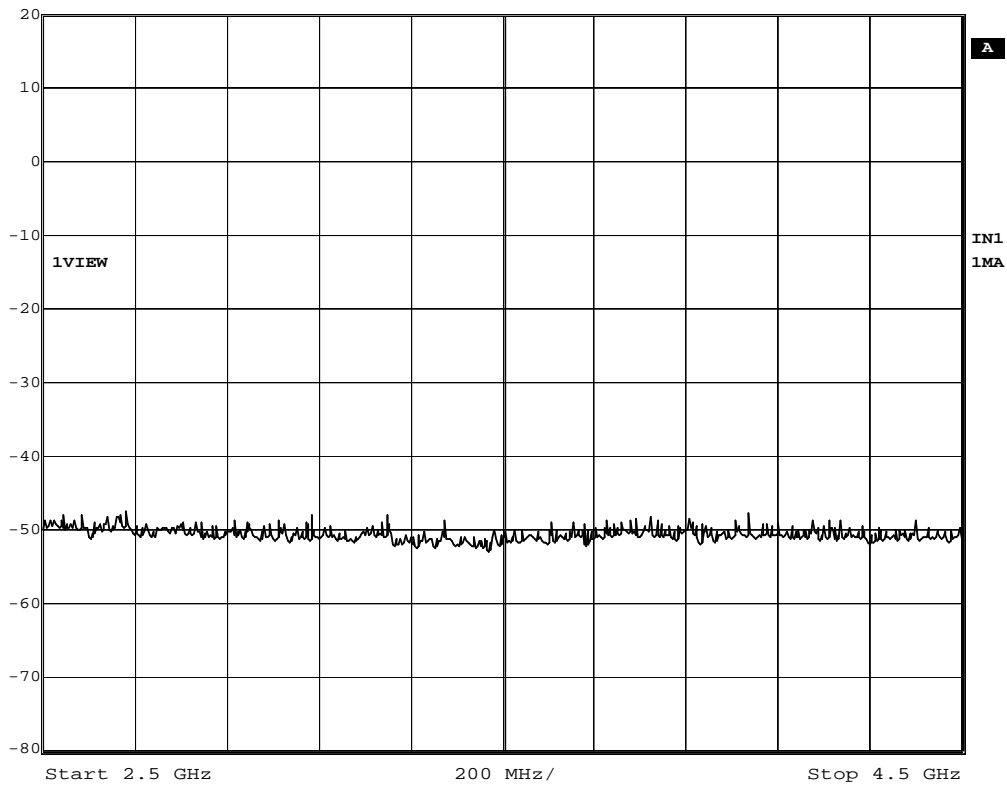

Start 2.5 GHz 200 MHz/ Stop 4.5 GHz

Date: 23.DEC.2008 17:36:25

(4.5-6.5G)



Ref Lvl  
20 dBm

RBW 1 MHz RF Att 30 dB  
VBW 1 MHz  
SWT 200 ms Unit dBm

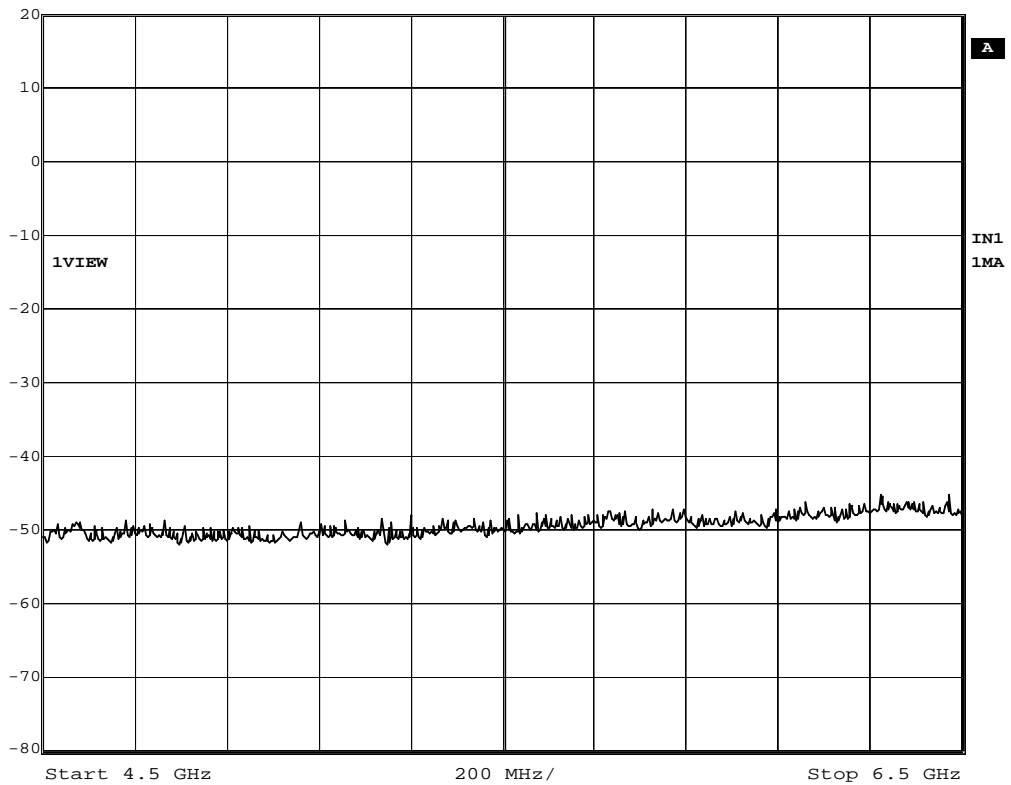

Date: 23.DEC.2008 17:43:16

(6.5-8.5G)



Ref Lvl  
20 dBm

RBW 1 MHz RF Att 30 dB  
VBW 1 MHz  
SWT 200 ms Unit dBm

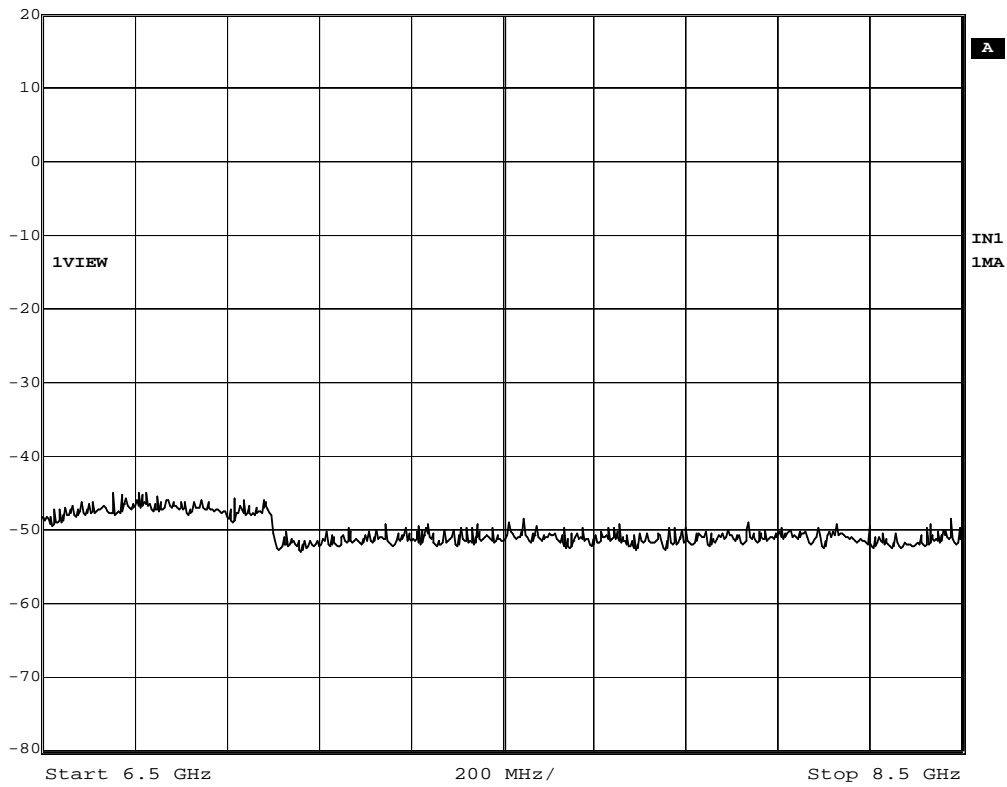

Date: 23.DEC.2008 17:43:51

(8.5-10.5G)



Ref Lvl  
20 dBm

RBW 1 MHz RF Att 30 dB  
VBW 1 MHz  
SWT 200 ms Unit dBm

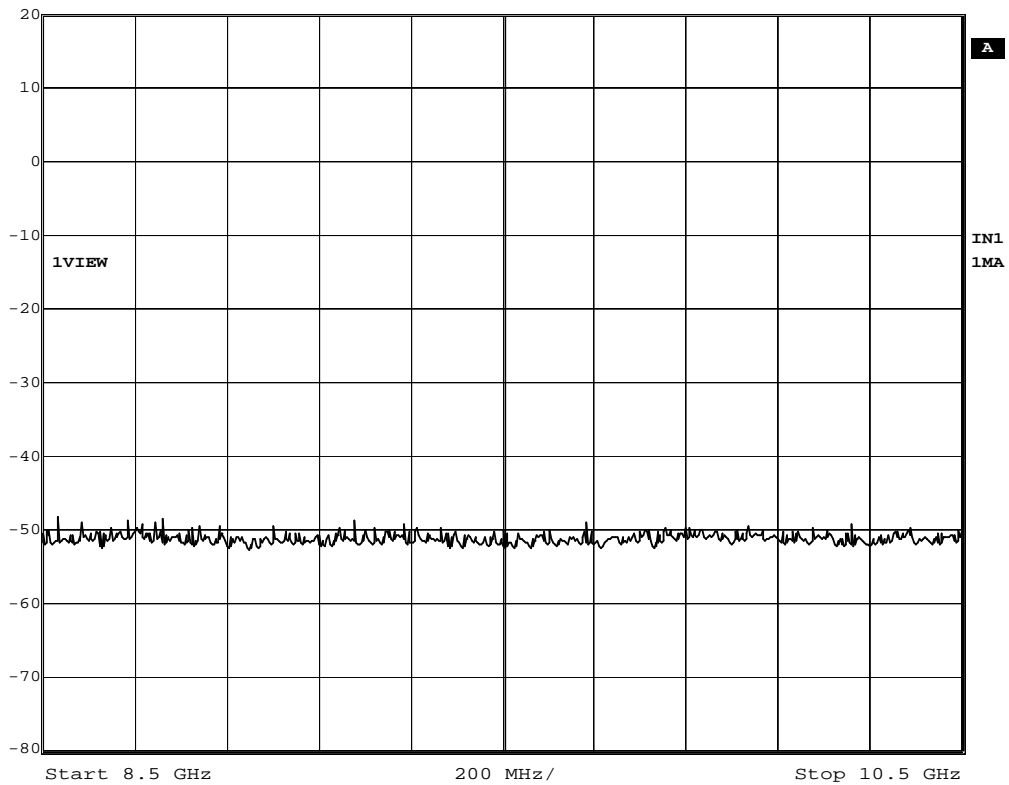

Date: 23.DEC.2008 17:44:48

(10.5-12.5G)



Ref Lvl  
20 dBm

RBW 1 MHz RF Att 30 dB  
VBW 1 MHz  
SWT 200 ms Unit dBm

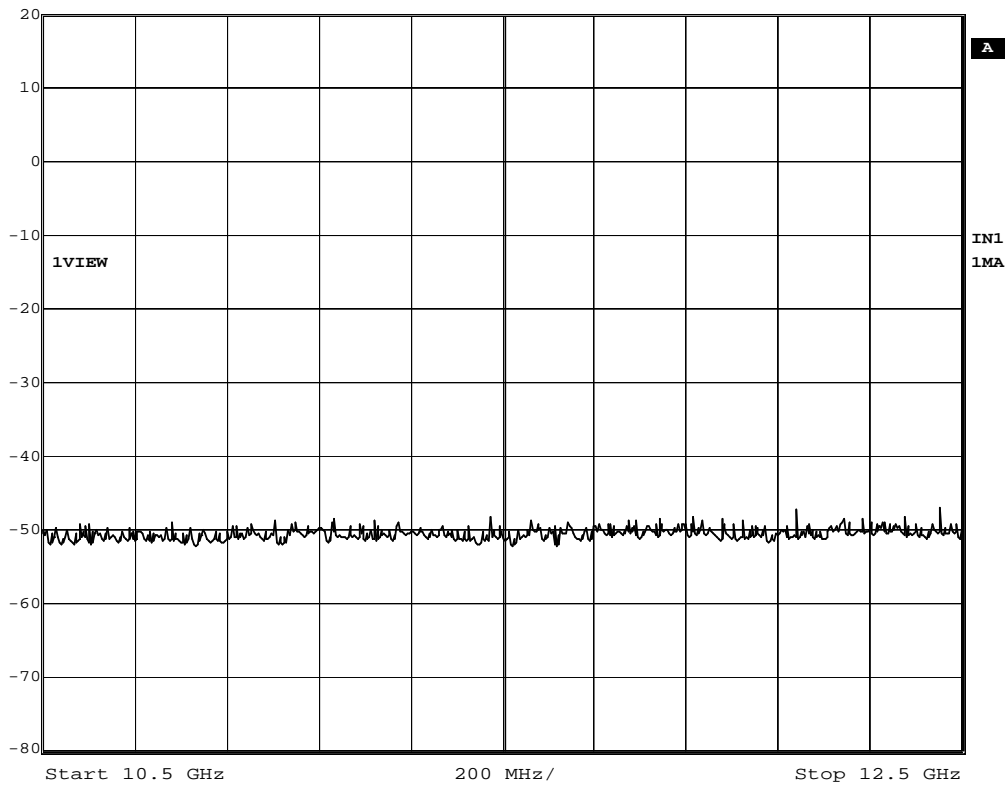

Date: 23.DEC.2008 17:46:09

(12.5-14.5G)



Ref Lvl  
20 dBm

RBW 1 MHz RF Att 30 dB  
VBW 1 MHz  
SWT 200 ms Unit dBm

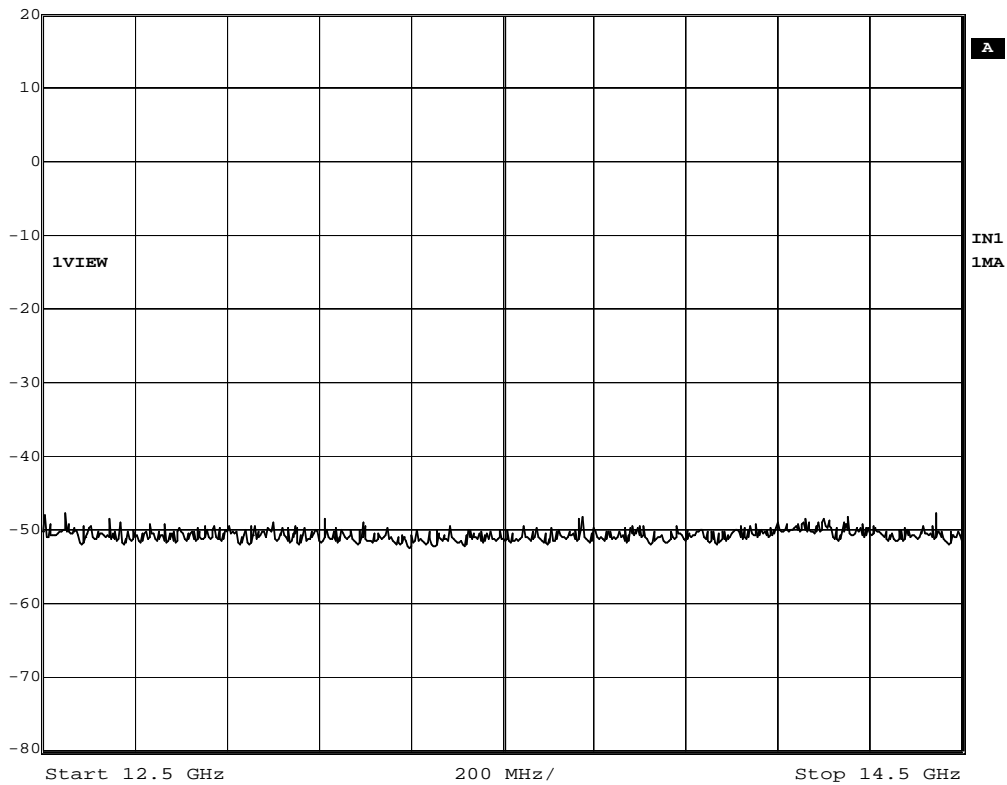

Start 12.5 GHz 200 MHz/ Stop 14.5 GHz

Date: 23.DEC.2008 17:48:30

(14.5-16.5G)



Ref Lvl  
20 dBm

RBW 1 MHz RF Att 30 dB  
VBW 1 MHz  
SWT 200 ms Unit dBm

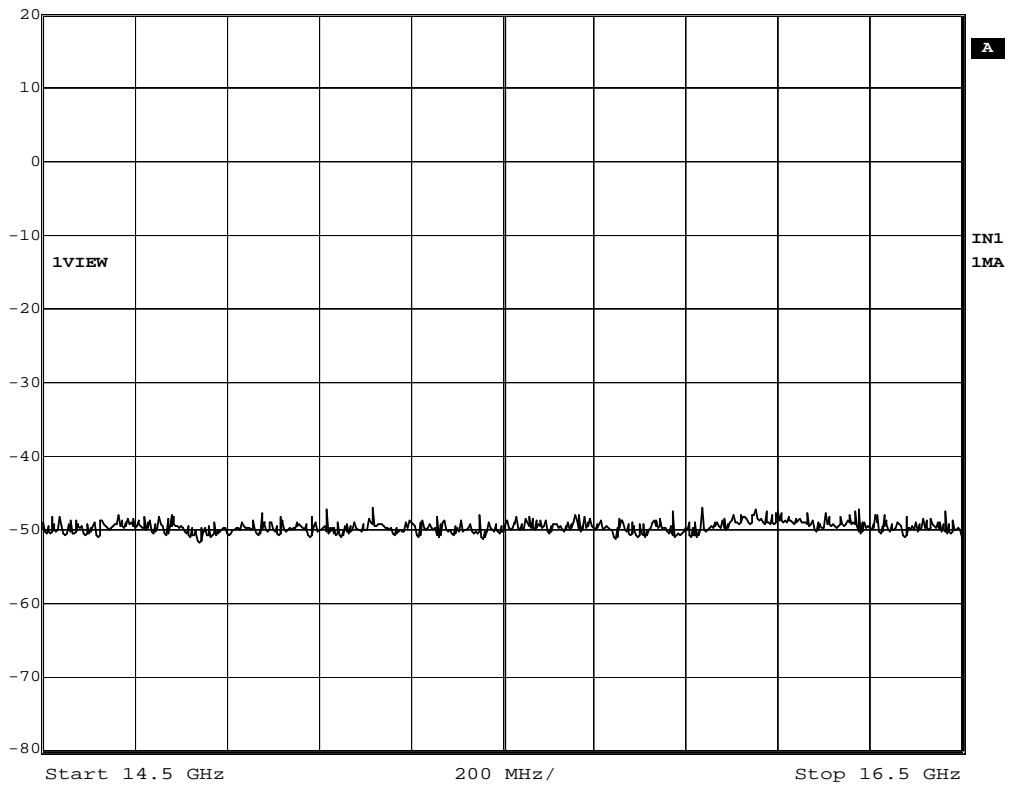

Start 14.5 GHz 200 MHz/ Stop 16.5 GHz

Date: 23.DEC.2008 17:49:02



(16.5-18.5G)



Ref Lvl  
20 dBm

RBW 1 MHz RF Att 30 dB  
VBW 1 MHz  
SWT 200 ms Unit dBm

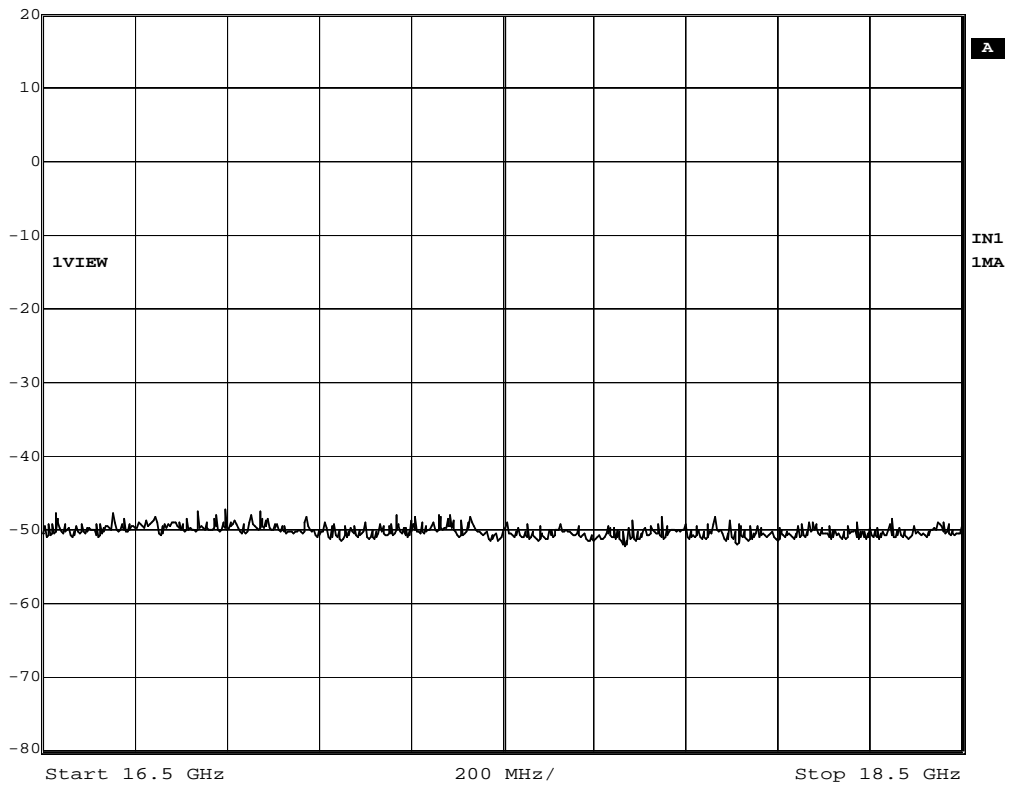

Date: 23.DEC.2008 17:49:30

(18.5-20.5G)



Ref Lvl  
20 dBm

RBW 1 MHz RF Att 30 dB  
VBW 1 MHz  
SWT 200 ms Unit dBm

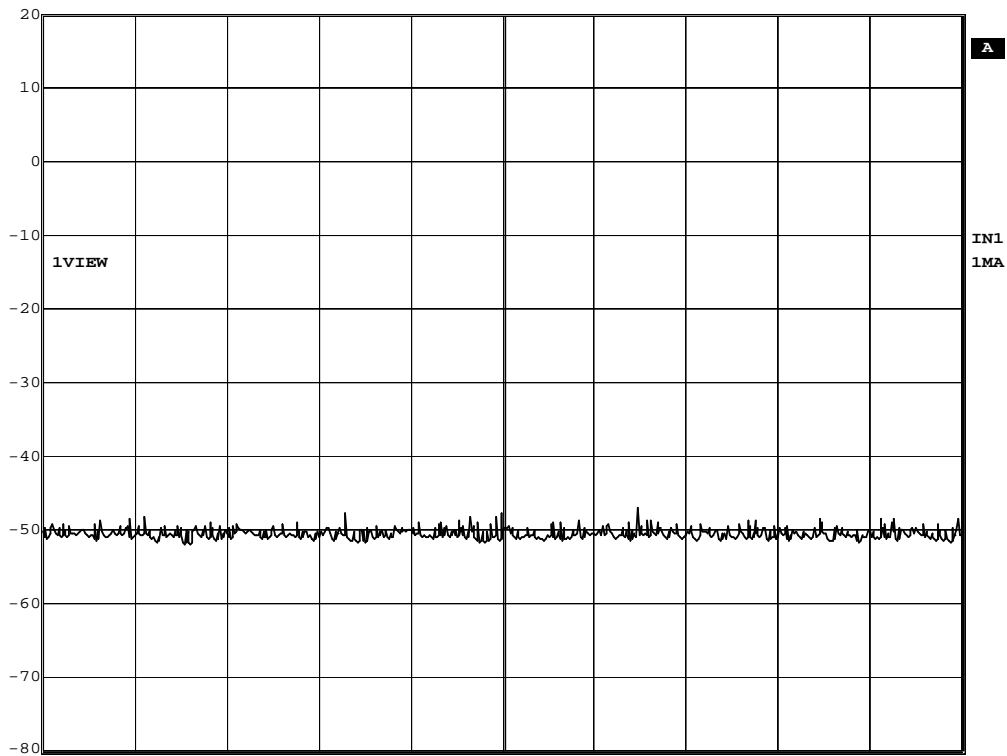

Center 20.5 GHz 20 ms/

Date: 23.DEC.2008 17:50:01

## (20.5-22.5G)



\* RBW 1 MHz  
\* VBW 1 MHz  
\* SWT 200 ms

Ref -10 dBm

\* Att 0 dB

1 PK  
VIEW

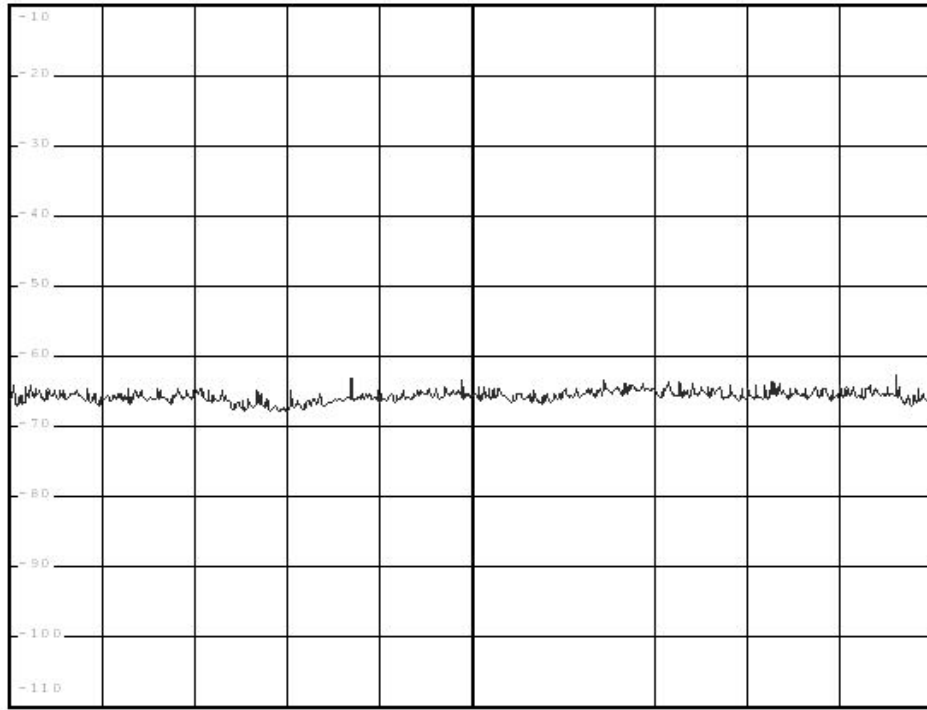

Date: 16 JAN 2009 16:47:40

(22.5-24.5G)



Ref Lvl  
20 dBm

RBW 1 MHz RF Att 30 dB  
VBW 1 MHz  
SWT 200 ms Unit dBm

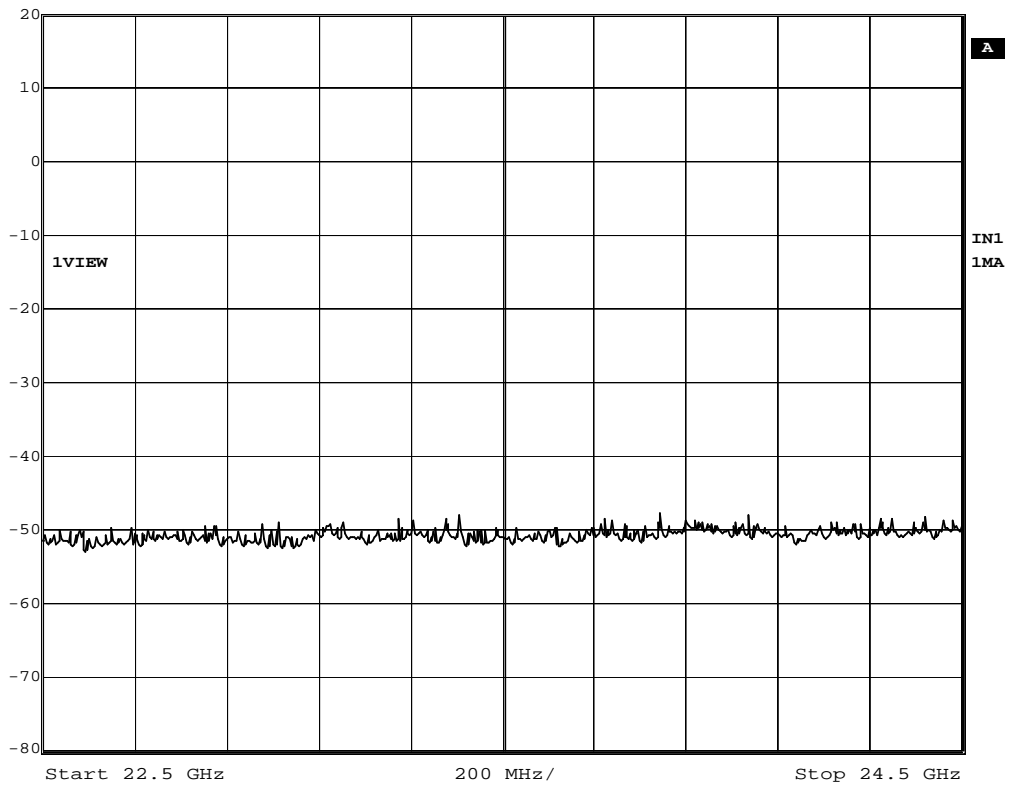

Date: 23.DEC.2008 17:51:18

(24.5-26.5G)



Ref Lvl  
20 dBm

RBW 1 MHz RF Att 30 dB  
VBW 1 MHz  
SWT 200 ms Unit dBm

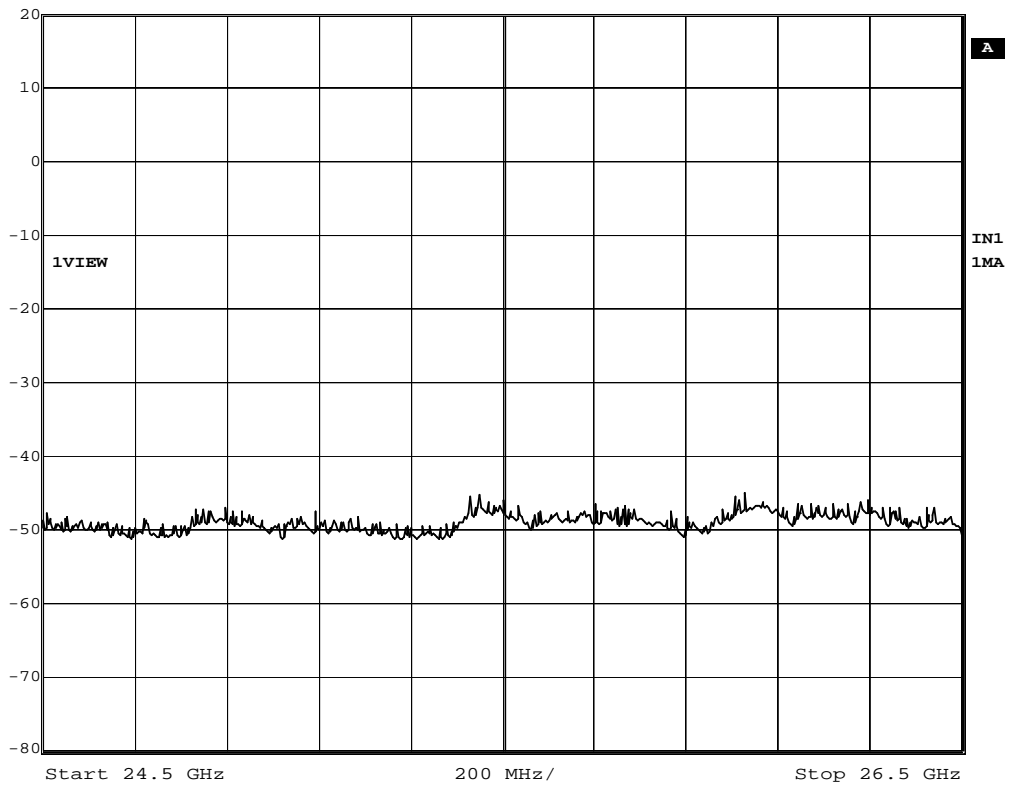

Date: 23.DEC.2008 17:51:51

6. Band Edge

6.1. Test Equipment

The following test equipments are used during the test:

RF Radiated Measurement:					
Item		Equipment	Manufacturer	Model No. / Serial No.	Last Cal.
1	X	Spectrum Analyzer	R & S	FSP40 / 100005	Aug., 2008
2	X	Pre-Amplifier	HP	8449B / 3008A01123	Feb., 2008
3		Loop Antenna	R & S	HFH2-Z2 / 833799/004	Sep., 2008
4		BiconiLog Antenna	Schwarzbeck	VULB 9166 / 1061	Sep., 2008
5		Bilog Antenna	Chase	CBL6112B / 2455	Sep., 2008
6	X	Horn Antenna	Schwarzbeck	BBHA 9120D / BBHA9120D312	Sep., 2008
7		No.1 OATS			Sep., 2008

- Note: 1. All equipments that need to calibrate are with calibration period of 1 year.  
 2. Mark "X" test instruments are used to measure the final test results.

6.2. Test Setup

RF Radiated Measurement:

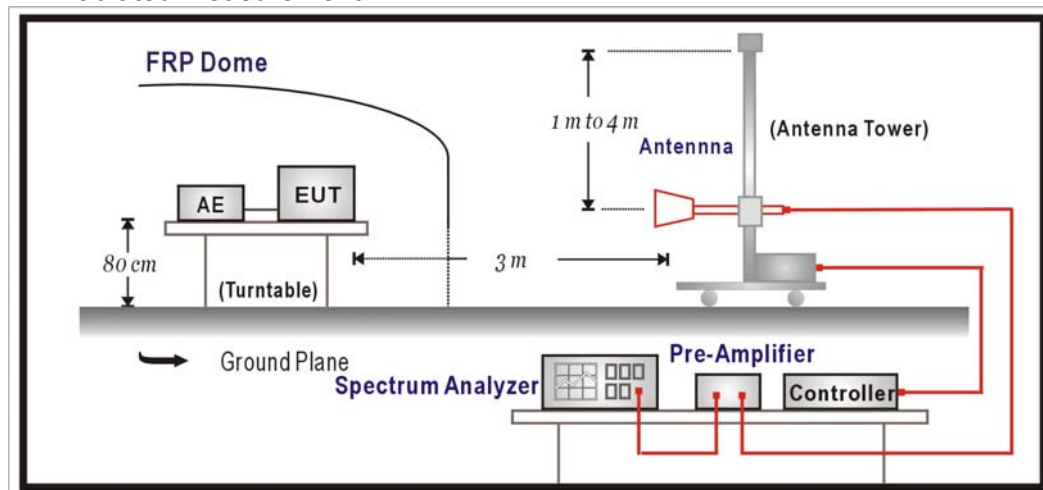

**6.3. Limits**

Emissions radiated outside of the specified frequency bands, except for harmonics, shall be attenuated by at least 20dB below the level of the fundamental or to the general radiated emission limits in paragraph 15.209, whichever is the lesser attenuation.

**6.4. Test Procedure**

The EUT was setup according to ANSI C63.4, 2003 and tested according to FHSS test procedure of FCC Public Notice DA 00-705 for compliance to FCC 47CFR 15.247 requirements

The EUT and its simulators are placed on a turn table which is 0.8 meter above ground. The turn table can rotate 360 degrees to determine the position of the maximum emission level. The EUT was positioned such that the distance from antenna to the EUT was 3 meters.

The antenna can move up and down between 1 meter and 4 meters to find out the maximum emission level.

Both horizontal and vertical polarization of the antenna are set on measurement. In order to find the maximum emission, all of the interface cables must be manipulated according to ANSI C63.4:2003 on radiated measurement.

**6.5. Test Specification**

According to FCC Part 15 Subpart C Paragraph 15.247: 2008

6.6. Test Result

Site : Site 1	Time : 2008/12/24 - 21:22
Limit : FCC_SpartC_15.247_H_03M_PK	Margin : 6
Probe : CB4_FCC_1-18G(2008-05) - HORIZONTAL	Power :
EUT : Conference Phone	Note : 2402MHz

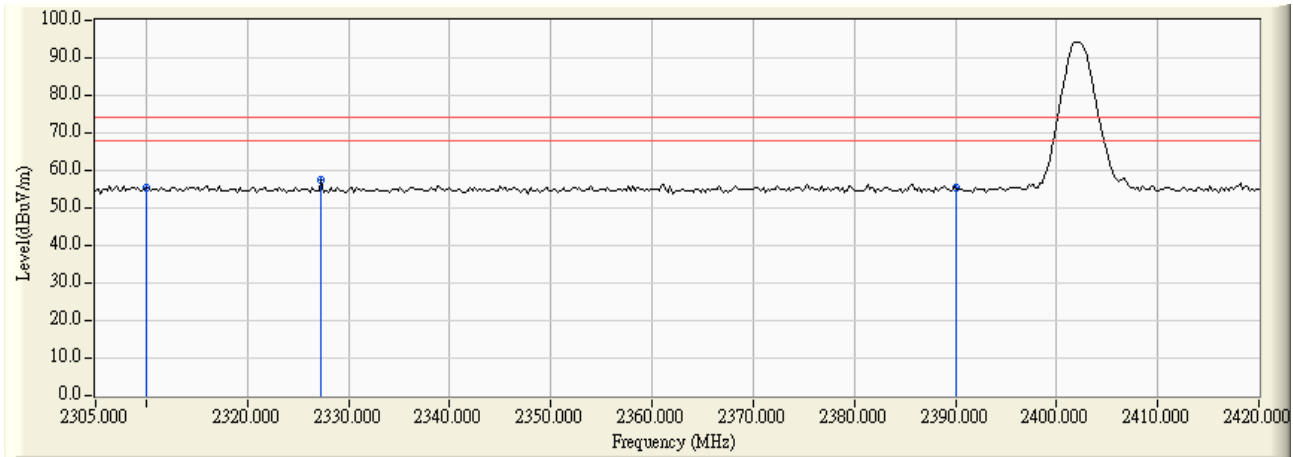

	Frequency (MHz)	Correct Factor (dB)	Reading Level (dBuV)	Measure Level (dBuV/m)	Margin (dB)	Limit (dBuV/m)	Detector Type
1	2310.000	30.823	24.414	55.236	-18.764	74.000	PEAK
2	* 2327.310	30.879	26.712	57.591	-16.409	74.000	PEAK
3	2390.000	31.087	24.227	55.314	-18.686	74.000	PEAK

Note:

1. All Readings below 1GHz are Quasi-Peak, above are performed with peak and/or average measurements as necessary.
2. “ \* ”, means this data is the worst emission level.
3. Measurement Level = Reading Level + Correct Factor
4. The average measurement was not performed when the peak measured data under the limit of average detection. If the readings given are average, peak measurement should also be supplied.



Site : Site 1	Time : 2008/12/24 - 21:24
Limit : FCC_SpartC_15.247_H_03M_AV	Margin : 6
Probe : CB4_FCC_1-18G(2008-05) - HORIZONTAL	Power :
EUT : Conference Phone	Note : 2402 MHz

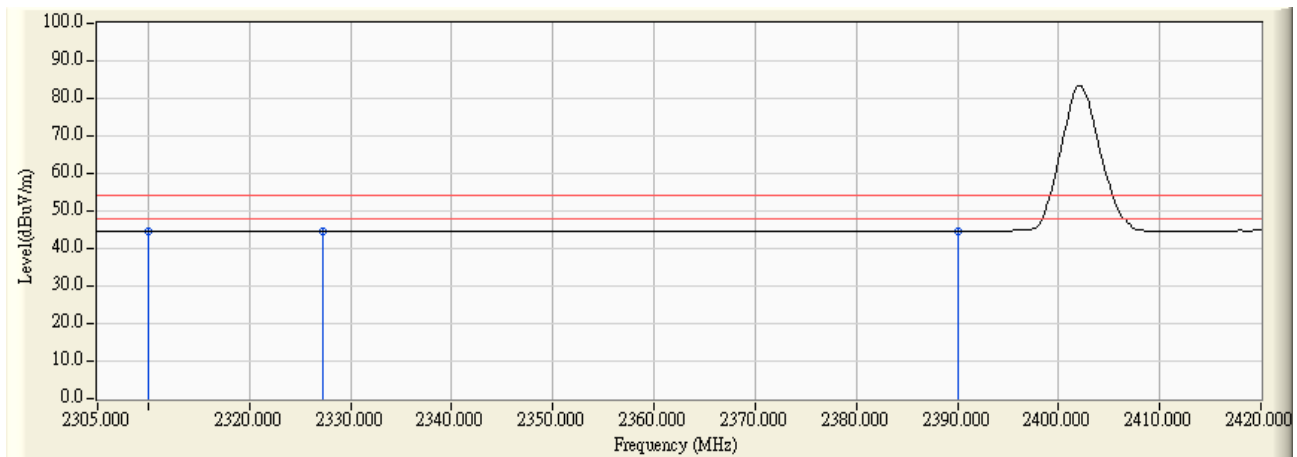

	Frequency (MHz)	Correct Factor (dB)	Reading Level (dBuV)	Measure Level (dBuV/m)	Margin (dB)	Limit (dBuV/m)	Detector Type
1	2310.000	30.823	13.743	44.565	-9.435	54.000	AVERAGE
2	* 2327.310	30.879	13.715	44.594	-9.406	54.000	AVERAGE
3	2390.000	31.087	13.671	44.758	-9.242	54.000	AVERAGE

**Note:**

1. All Readings below 1GHz are Quasi-Peak, above are performed with peak and/or average measurements as necessary.
2. “ \* ”, means this data is the worst emission level.
3. Measurement Level = Reading Level + Correct Factor
4. The average measurement was not performed when the peak measured data under the limit of average detection. If the readings given are average, peak measurement should also be supplied.

Site : Site 1	Time : 2008/12/24 - 21:27
Limit : FCC_SpartC_15.247_H_03M_PK	Margin : 6
Probe : CB4_FCC_1-18G(2008-05) - VERTICAL	Power :
EUT : Conference Phone	Note : 2402 MHz

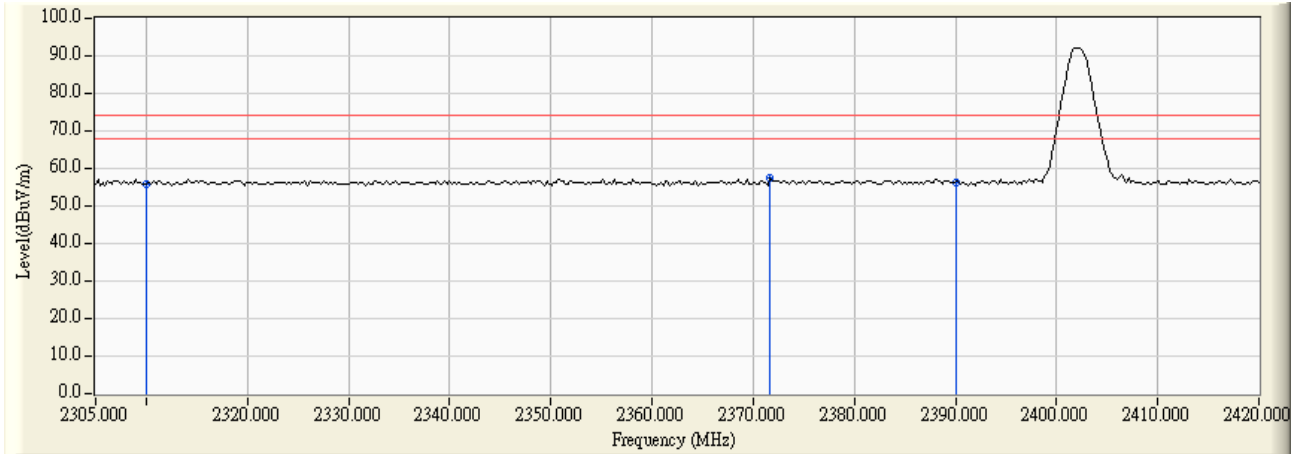

	Frequency (MHz)	Correct Factor (dB)	Reading Level (dBuV)	Measure Level (dBuV/m)	Margin (dB)	Limit (dBuV/m)	Detector Type
1	2310.000	30.823	24.996	55.818	-18.182	74.000	PEAK
2	* 2371.700	31.027	26.462	57.488	-16.512	74.000	PEAK
3	2390.000	31.087	25.253	56.340	-17.660	74.000	PEAK

**Note:**

1. All Readings below 1GHz are Quasi-Peak, above are performed with peak and/or average measurements as necessary.
2. “ \* ”, means this data is the worst emission level.
3. Measurement Level = Reading Level + Correct Factor
4. The average measurement was not performed when the peak measured data under the limit of average detection. If the readings given are average, peak measurement should also be supplied.

Site : Site 1	Time : 2008/12/24 - 21:29
Limit : FCC_SpartC_15.247_H_03M_AV	Margin : 6
Probe : CB4_FCC_1-18G(2008-05) - VERTICAL	Power :
EUT : Conference Phone	Note : 2402 MHz

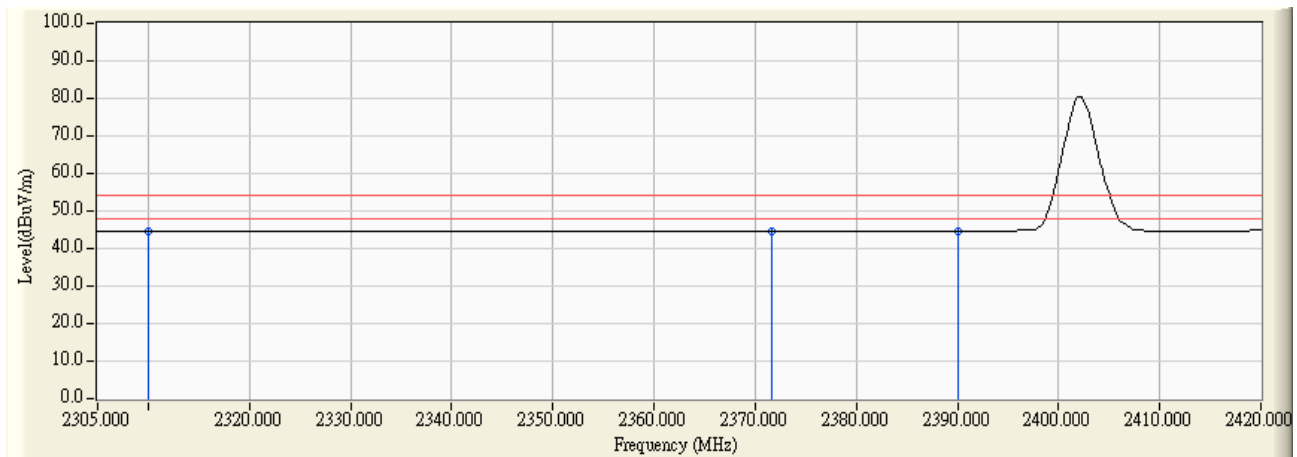

	Frequency (MHz)	Correct Factor (dB)	Reading Level (dBuV)	Measure Level (dBuV/m)	Margin (dB)	Limit (dBuV/m)	Detector Type
1	2310.000	30.823	13.752	44.574	-9.426	54.000	AVERAGE
2	* 2371.700	31.027	13.592	44.618	-9.382	54.000	AVERAGE
3	2390.000	31.087	13.657	44.744	-9.256	54.000	AVERAGE

**Note:**

1. All Readings below 1GHz are Quasi-Peak, above are performed with peak and/or average measurements as necessary.
2. “ \* ”, means this data is the worst emission level.
3. Measurement Level = Reading Level + Correct Factor
4. The average measurement was not performed when the peak measured data under the limit of average detection. If the readings given are average, peak measurement should also be supplied.

Site : Site 1	Time : 2008/12/24 - 21:35
Limit : FCC_SpartC_15.247_H_03M_PK	Margin : 6
Probe : CB4_FCC_1-18G(2008-05) - HORIZONTAL	Power :
EUT : Conference Phone	Note : 2480 MHz

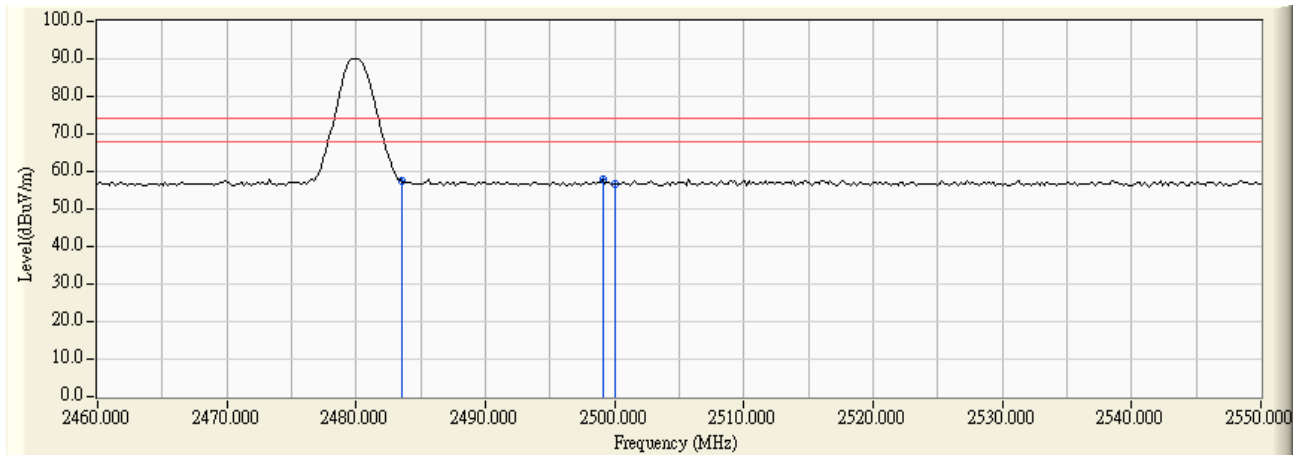

	Frequency (MHz)	Correct Factor (dB)	Reading Level (dBuV)	Measure Level (dBuV/m)	Margin (dB)	Limit (dBuV/m)	Detector Type
1	2483.500	31.407	25.960	57.366	-16.634	74.000	PEAK
2	* 2499.060	31.454	26.430	57.884	-16.116	74.000	PEAK
3	2500.000	31.456	25.214	56.670	-17.330	74.000	PEAK

**Note:**

1. All Readings below 1GHz are Quasi-Peak, above are performed with peak and/or average measurements as necessary.
2. “ \* ”, means this data is the worst emission level.
3. Measurement Level = Reading Level + Correct Factor
4. The average measurement was not performed when the peak measured data under the limit of average detection. If the readings given are average, peak measurement should also be supplied.

Site : Site 1	Time : 2008/12/24 - 21:36
Limit : FCC_SpartC_15.247_H_03M_AV	Margin : 6
Probe : CB4_FCC_1-18G(2008-05) - HORIZONTAL	Power :
EUT : Conference Phone	Note : 2480 MHz

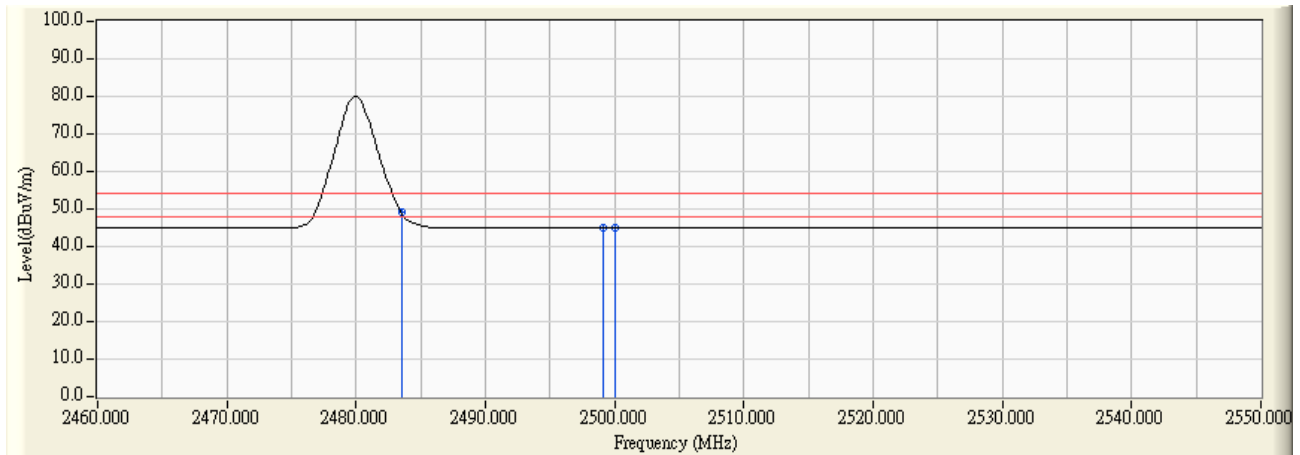

	Frequency (MHz)	Correct Factor (dB)	Reading Level (dBuV)	Measure Level (dBuV/m)	Margin (dB)	Limit (dBuV/m)	Detector Type
1	2483.500	31.407	17.603	49.009	-4.991	54.000	AVERAGE
2	* 2499.060	31.454	13.629	45.083	-8.917	54.000	AVERAGE
3	2500.000	31.456	13.623	45.079	-8.921	54.000	AVERAGE

**Note:**

1. All Readings below 1GHz are Quasi-Peak, above are performed with peak and/or average measurements as necessary.
2. “ \* ”, means this data is the worst emission level.
3. Measurement Level = Reading Level + Correct Factor
4. The average measurement was not performed when the peak measured data under the limit of average detection. If the readings given are average, peak measurement should also be supplied.

Site : Site 1	Time : 2008/12/24 - 21:42
Limit : FCC_SpartC_15.247_H_03M_PK	Margin : 6
Probe : CB4_FCC_1-18G(2008-05) - VERTICAL	Power :
EUT : Conference Phone	Note : 2480 MHz

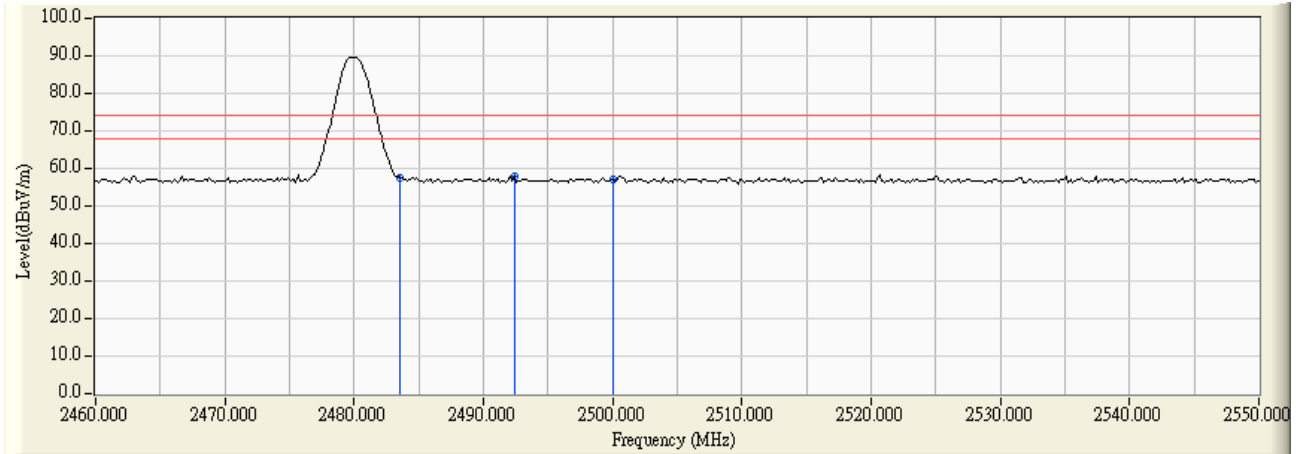

	Frequency (MHz)	Correct Factor (dB)	Reading Level (dBuV)	Measure Level (dBuV/m)	Margin (dB)	Limit (dBuV/m)	Detector Type
1	2483.500	31.407	26.205	57.611	-16.389	74.000	PEAK
2	* 2492.400	31.436	26.432	57.868	-16.132	74.000	PEAK
3	2500.000	31.456	25.447	56.903	-17.097	74.000	PEAK

**Note:**

1. All Readings below 1GHz are Quasi-Peak, above are performed with peak and/or average measurements as necessary.
2. “ \* ”, means this data is the worst emission level.
3. Measurement Level = Reading Level + Correct Factor
4. The average measurement was not performed when the peak measured data under the limit of average detection. If the readings given are average, peak measurement should also be supplied.

Site : Site 1	Time : 2008/12/24 - 21:44
Limit : FCC_SpartC_15.247_H_03M_AV	Margin : 6
Probe : CB4_FCC_1-18G(2008-05) - VERTICAL	Power :
EUT : Conference Phone	Note : 2480 MHz

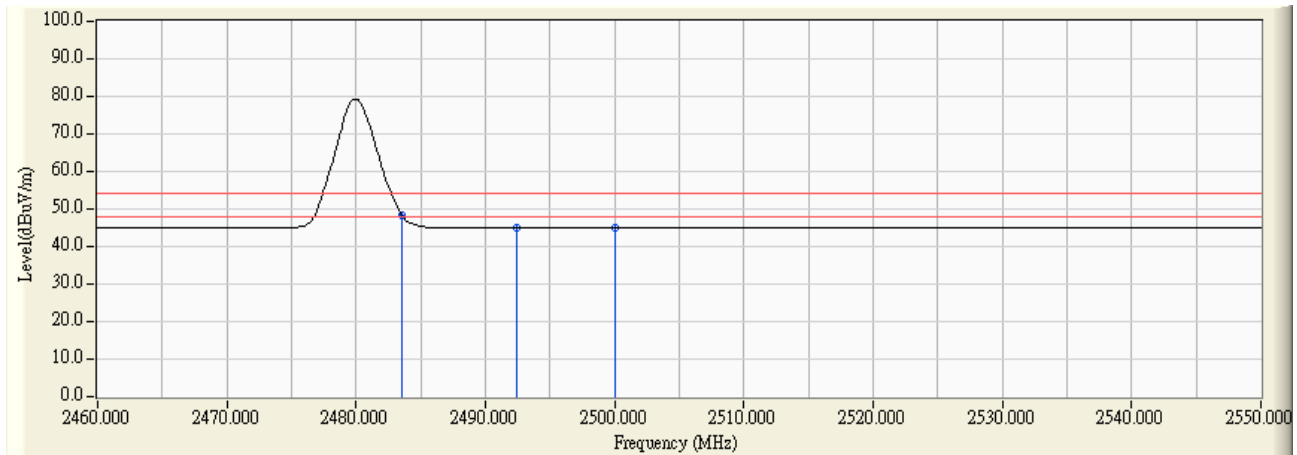

	Frequency (MHz)	Correct Factor (dB)	Reading Level (dBuV)	Measure Level (dBuV/m)	Margin (dB)	Limit (dBuV/m)	Detector Type
1	2483.500	31.407	17.090	48.496	-5.504	54.000	AVERAGE
2	* 2492.400	31.436	13.611	45.047	-8.953	54.000	AVERAGE
3	2500.000	31.456	13.631	45.087	-8.913	54.000	AVERAGE

**Note:**

1. All Readings below 1GHz are Quasi-Peak, above are performed with peak and/or average measurements as necessary.
2. “ \* ”, means this data is the worst emission level.
3. Measurement Level = Reading Level + Correct Factor
4. The average measurement was not performed when the peak measured data under the limit of average detection. If the readings given are average, peak measurement should also be supplied.

**7. Number of hopping frequency**

**7.1. Test Equipment**

The following test equipments are used during the test:

Item	Equipment	Manufacturer	Model No. / Serial No.	Last Cal.
1	Spectrum Analyzer	R & S	FSP / 100561	Mar., 2008
2	No.1 OATS			Sep., 2008

Note: 1. All equipments that need to calibrate are with calibration period of 1 year.

**7.2. Test Setup**

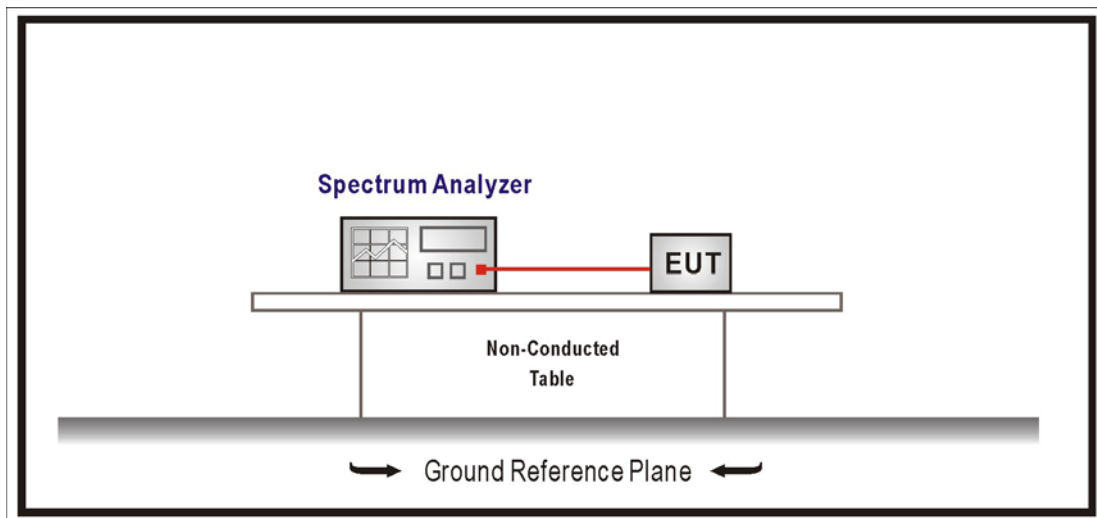



**7.3. Limits**

For frequency hopping systems operating in the 902-928 MHz band: if the 20 dB bandwidth of the hopping channel is less than 250 kHz, the system shall use at least 50 hopping frequencies and the average time of occupancy on any frequency shall not be greater than 0.4 seconds within a 20 second period; if the 20 dB bandwidth of the hopping channel is 250 kHz or greater, the system shall use at least 25 hopping frequencies and the average time of occupancy on any frequency shall not be greater than 0.4 seconds within a 10 second period. The maximum allowed 20 dB bandwidth of the hopping channel is 500 kHz.

For frequency hopping systems operating in the 2400-2483.5 MHz bands, which use fewer than 75 hopping frequencies, may employ intelligent hopping techniques to avoid interference to other transmissions. Frequency hopping systems may avoid or suppress transmissions on a particular hopping frequency provided that a minimum of 15 non-overlapping channels are used.

For frequency hopping systems operating in the 5725-5850 MHz band shall use at least 75 hopping frequencies.

**7.4. Test Procedures**

The EUT was setup according to ANSI C63.4, 2003 and tested according to FHSS test procedure of FCC Public Notice DA 00-705 for compliance to FCC 47CFR 15.247 requirements

Span = the frequency band of operation

RBW  $\geq$  1% of the span , VBW  $\geq$  RBW

Sweep = auto, Detector function = peak, Trace = max hold

**7.5. Test Specification**

According to FCC Part 15 Subpart C Paragraph 15.247: 2008

## 7.6. Test Result

Product	Conference Phone		
Test Item	Number of hopping frequency		
Test Mode	Transmit		
Date of Test	2008/12/23	Test Site	No.1 OATS

Frequency Range (MHz)	Measure Level (Hopping Channel)	Limit (Hopping Channel)	Result
2402 ~ 2480	79	>75	Pass

### 2402-2420MHz

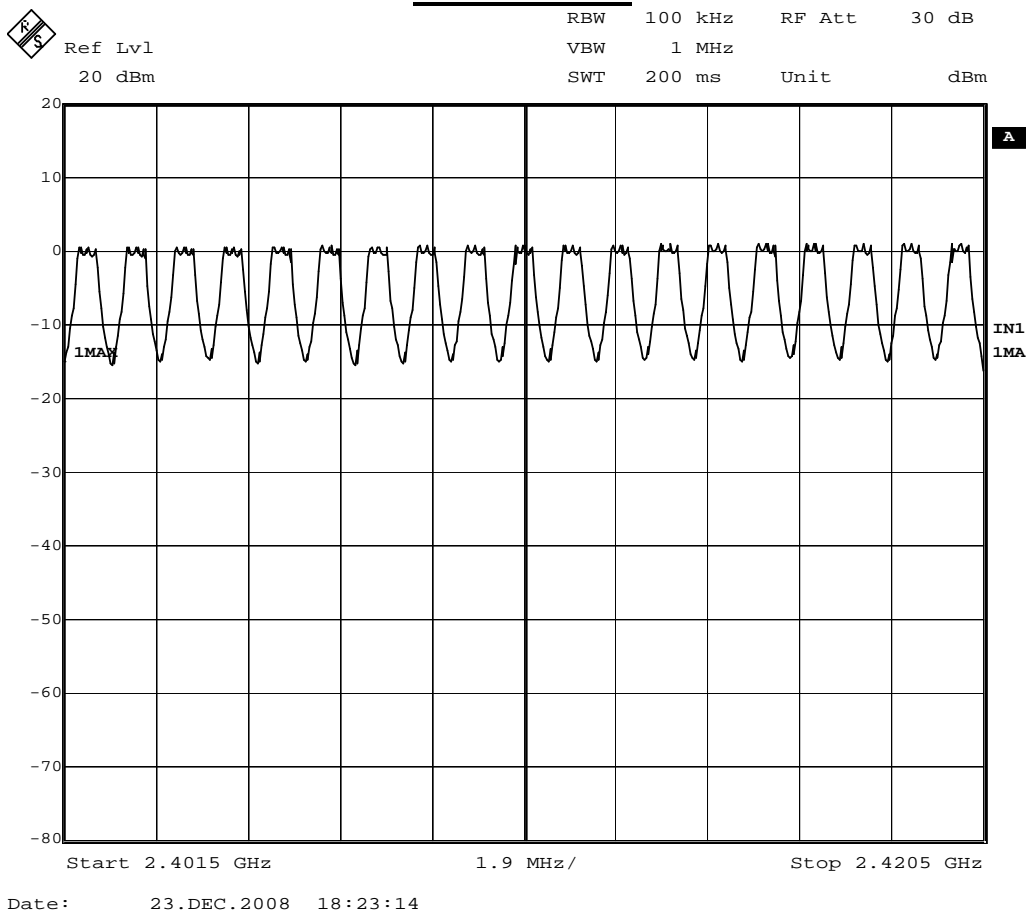

**2421-2440MHz**



\*RBW 100 kHz    Marker 1 [T1 ]  
\*VBW 1 MHz                    1.22 dBm  
\*SWT 200 ms                    2.432020000 GHz

Ref 20 dBm                    \*Att 30 dB

1 PK  
MAXH

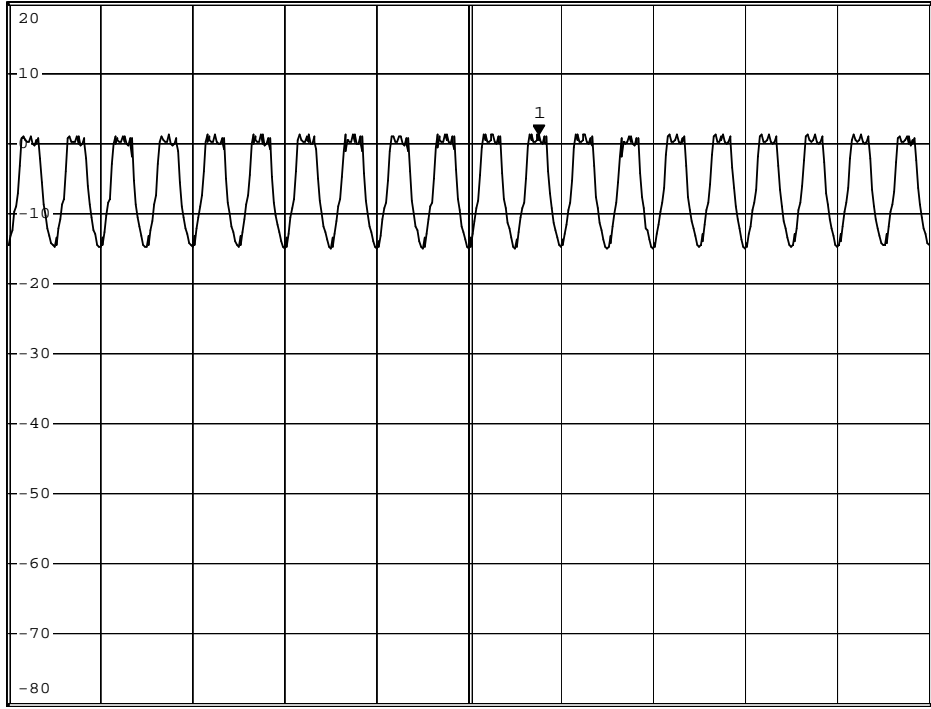

Start 2.4205 GHz                    2 MHz/                    Stop 2.4405 GHz

Date:                    24.DEC.2008    10:47:50

2441-2460MHz



\*RBW 100 kHz Marker 1 [T1 ]  
\*VBW 1 MHz -14.33 dBm  
\*SWT 200 ms 2.440500000 GHz

Ref 20 dBm

\*Att 30 dB

1 PK  
MAXH

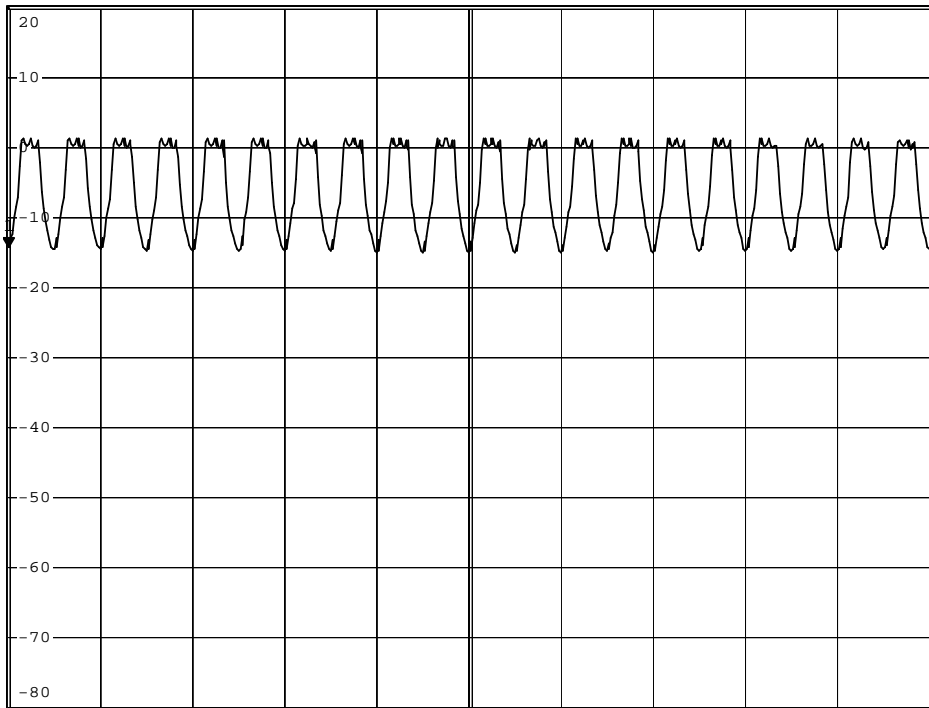

Start 2.4405 GHz 2 MHz/ Stop 2.4605 GHz

Date: 24.DEC.2008 10:50:50

**2461-2480MHz**



\*RBW 100 kHz    Marker 1 [T1 ]  
\*VBW 1 MHz                                -14.52 dBm  
\*SWT 200 ms                                2.460500000 GHz

Ref 20 dBm

\*Att 30 dB

1 PK  
MAXH

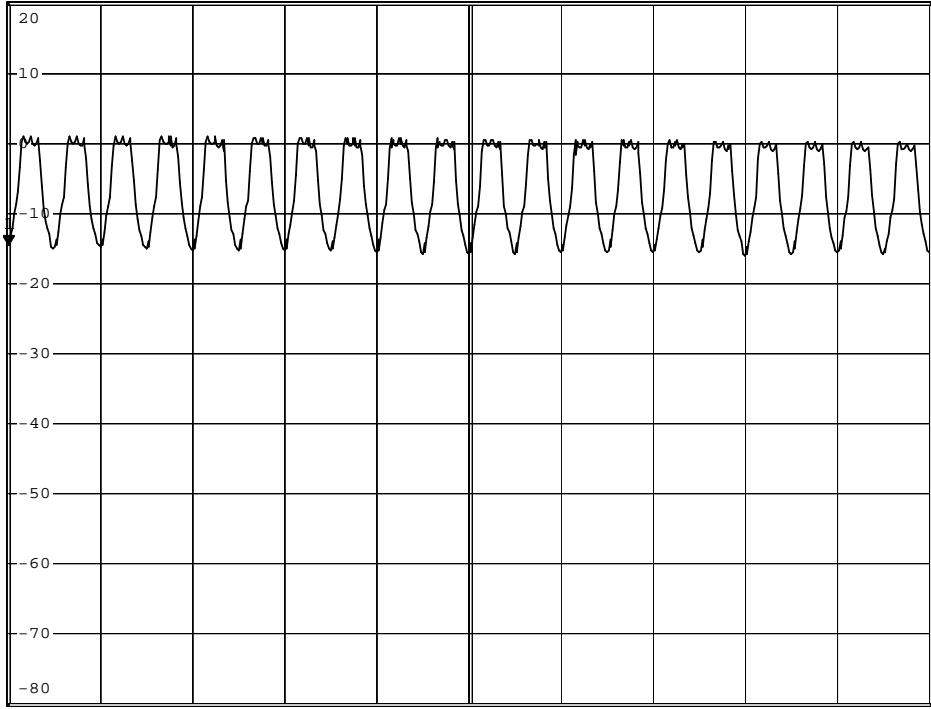

Center 2.4705 GHz

2 MHz/

Span 20 MHz

Date: 24.DEC.2008 12:08:17

**8. Carrier Frequency Separation**

**8.1. Test Equipment**

The following test equipment are used during the test:

Item	Equipment	Manufacturer	Model No. / Serial No.	Last Cal.
1	Spectrum Analyzer	R & S	FSP / 100561	Mar., 2008
2	No.1 OATS			Sep., 2008

Note: 1. All equipments that need to calibrate are with calibration period of 1 year.

**8.2. Test Setup**

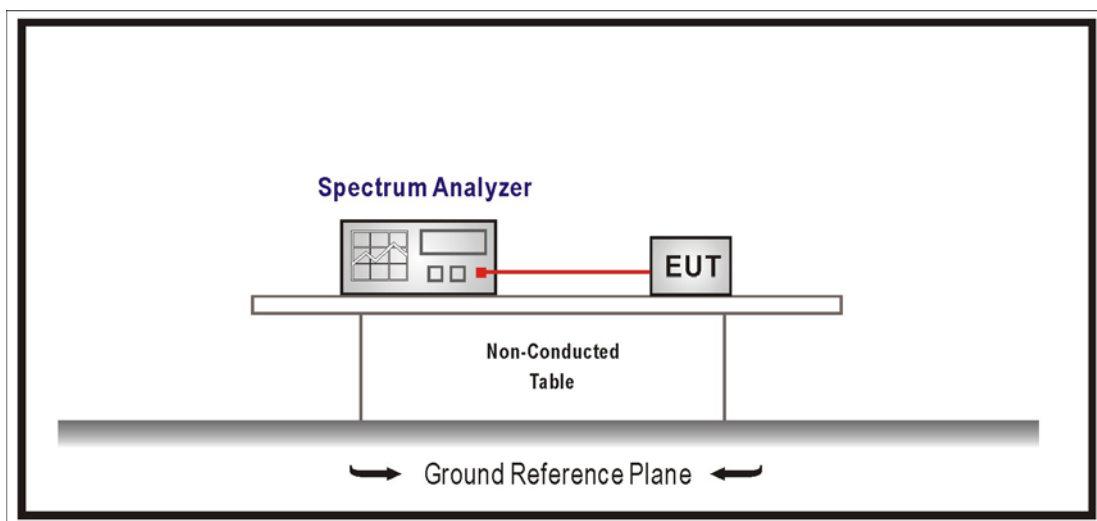

**8.3. Limits**

For frequency hopping systems shall have hopping channel carrier frequencies separated by a minimum of 25 kHz or the 20 dB bandwidth of the hopping channel, whichever is greater.

**8.4. Test Procedures**

The EUT was setup according to ANSI C63.4, 2003 and tested according to FHSS test procedure of FCC Public Notice DA 00-705 for compliance to FCC 47CFR 15.247 requirements

Span = wide enough to capture the peaks of two adjacent channels

Resolution Bandwidth (RBW)  $\geq$  1% of the span, VBW  $\geq$  RBW

Sweep = auto, Detector function = peak, Trace = max hold

**8.5. Test Specification**

According to FCC Part 15 Subpart C Paragraph 15.247: 2008

## 8.6. Test Result

Product	Conference Phone		
Test Item	Carrier Frequency Separation		
Test Mode	Transmit		
Date of Test	2008/12/24	Test Site	No.1 OATS

Channel No.	Frequency (MHz)	Measure Level (kHz)	Limit (kHz)	Result
00	2402.00	825.0	>746.4	Pass

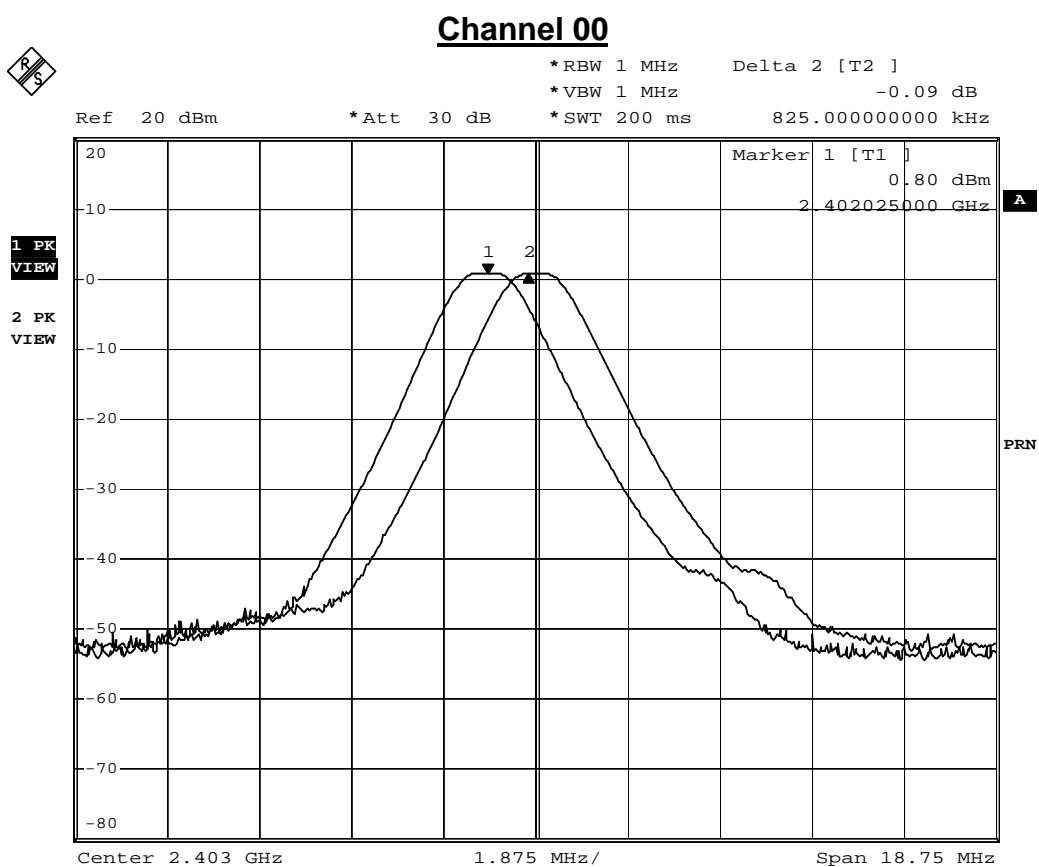

Date: 24.DEC.2008 10:38:11

Product	Conference Phone		
Test Item	Carrier Frequency Separation		
Test Mode	Transmit		
Date of Test	2008/12/23	Test Site	No.1 OATS

Channel No.	Frequency (MHz)	Measure Level (kHz)	Limit (kHz)	Result
39	2441.00	864.2	>746.6	Pass

### Channel 39

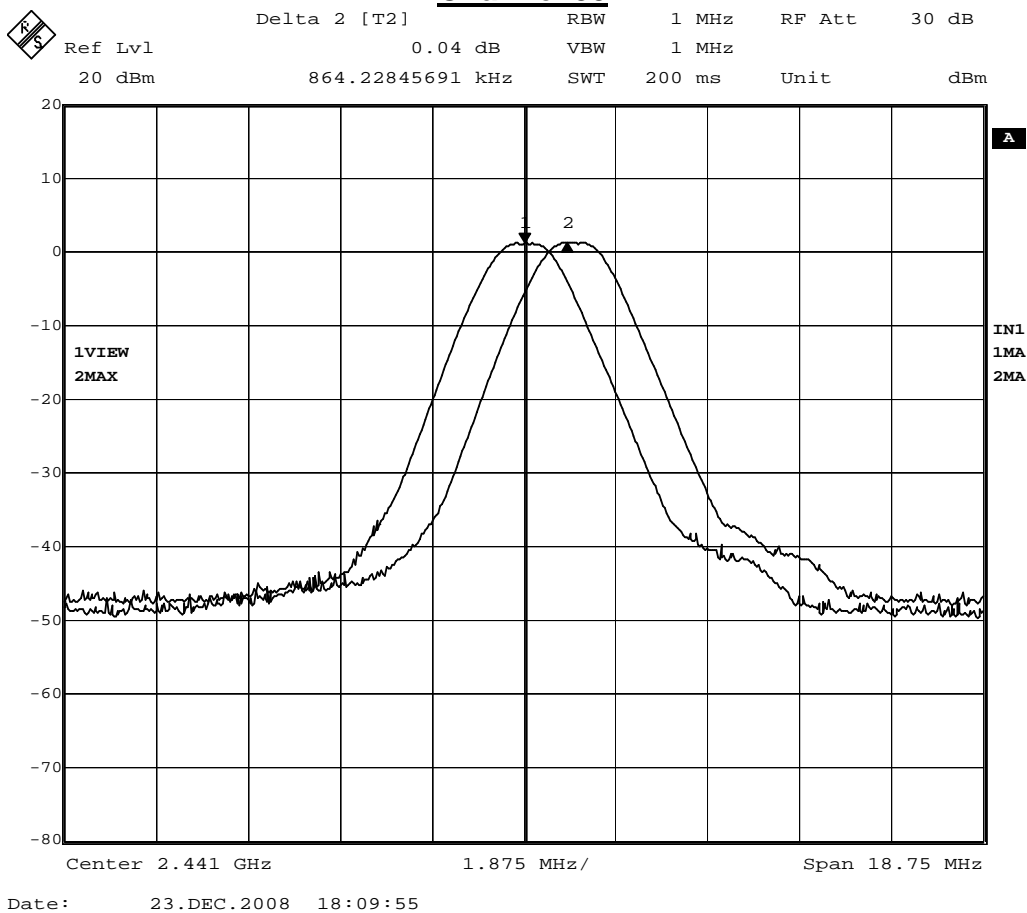



Product	Conference Phone		
Test Item	Carrier Frequency Separation		
Test Mode	Transmit		
Date of Test	2008/12/24	Test Site	No.1 OATS

Channel No.	Frequency (MHz)	Measure Level (kHz)	Limit (kHz)	Result
78	2480.00	975.0	>746.8	Pass

### Channel 78

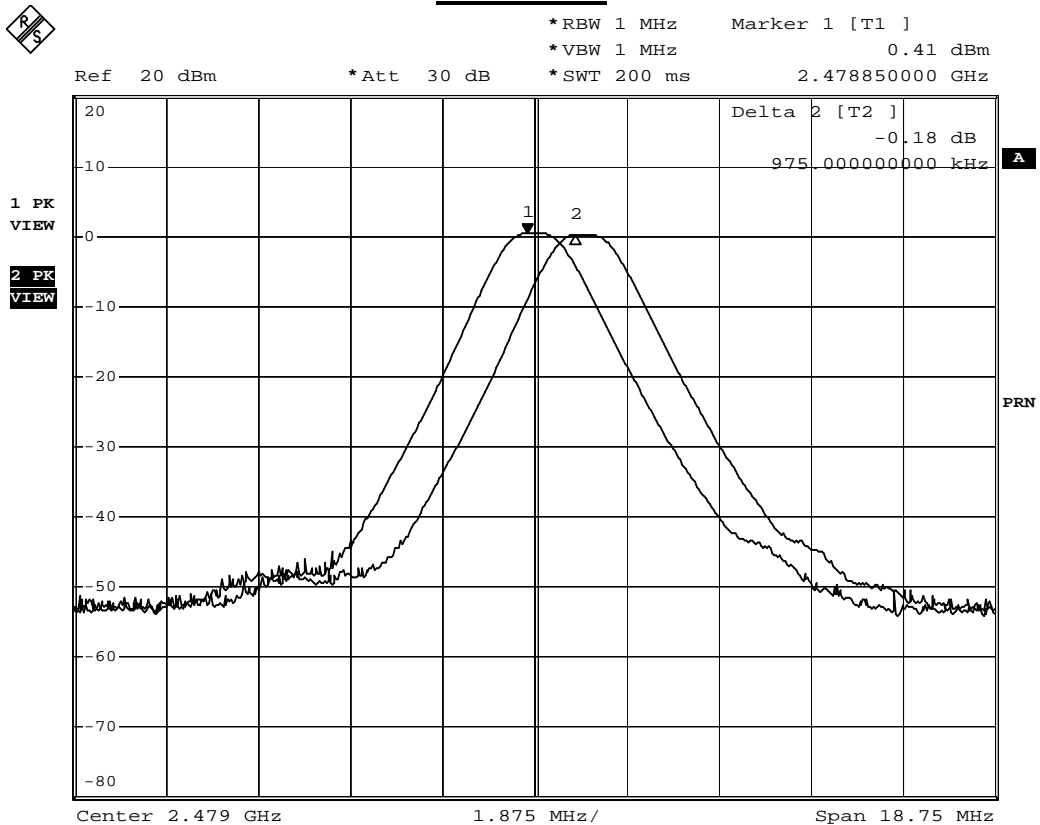

Date: 24.DEC.2008 10:39:59

**9. Occupied Bandwidth**

**9.1. Test Equipment**

The following test equipment are used during the test:

Item	Equipment	Manufacturer	Model No. / Serial No.	Last Cal.
1	Spectrum Analyzer	R & S	FSP / 100561	Mar., 2008
2	No.1 OATS			Sep., 2008

Note: 1. All equipments that need to calibrate are with calibration period of 1 year.

**9.2. Test Setup**

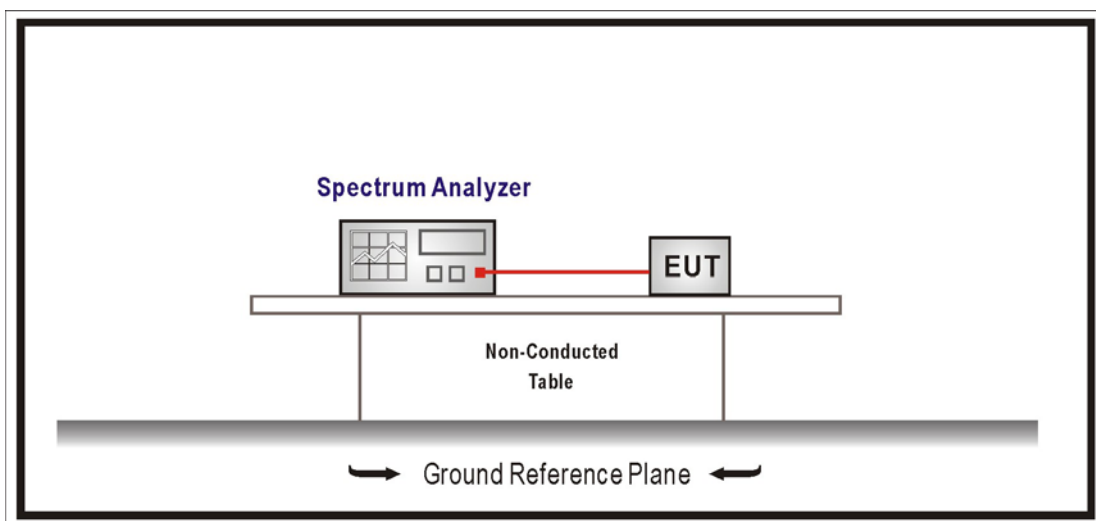

### 9.3. Limits

Frequency hopping systems operating in the 902-928 MHz band: the maximum allowed 20 dB bandwidth of the hopping channel is 500 kHz.

Frequency hopping systems operating in the 2400-2483.5 MHz band: the maximum allowed 20 dB bandwidth of the hopping channel is not determined in standard.

Frequency hopping systems operating in the 5725-5850 MHz band: the maximum allowed 20 dB bandwidth of the hopping channel is 1 MHz.

### 9.4. Test Procedures

The EUT was setup according to ANSI C63.4, 2003 and tested according to FHSS test procedure of FCC Public Notice DA 00-705 for compliance to FCC 47CFR 15.247 requirements

Use the following spectrum analyzer settings:

Span = approximately 2 to 3 times the 20 dB bandwidth, centered on a hopping channel

RBW  $\geq$  1% of the 20 dB bandwidth, VBW  $\geq$  RBW

Sweep = auto, Detector function = peak, Trace = max hold

The EUT should be transmitting at its maximum data rate.

### 9.5. Test Specification

According to FCC Part 15 Subpart C Paragraph 15.247: 2008

9.6. Test Result

Product	Conference Phone		
Test Item	Occupied Bandwidth		
Test Mode	Transmit		
Date of Test	2008/12/23	Test Site	No.1 OATS

1M-GFSK Modulation, PRBS Packet Type

Channel No.	Frequency (MHz)	Measure Level (MHz)	Limit (MHz)	Result
00	2402.00	1.1681	--	Pass

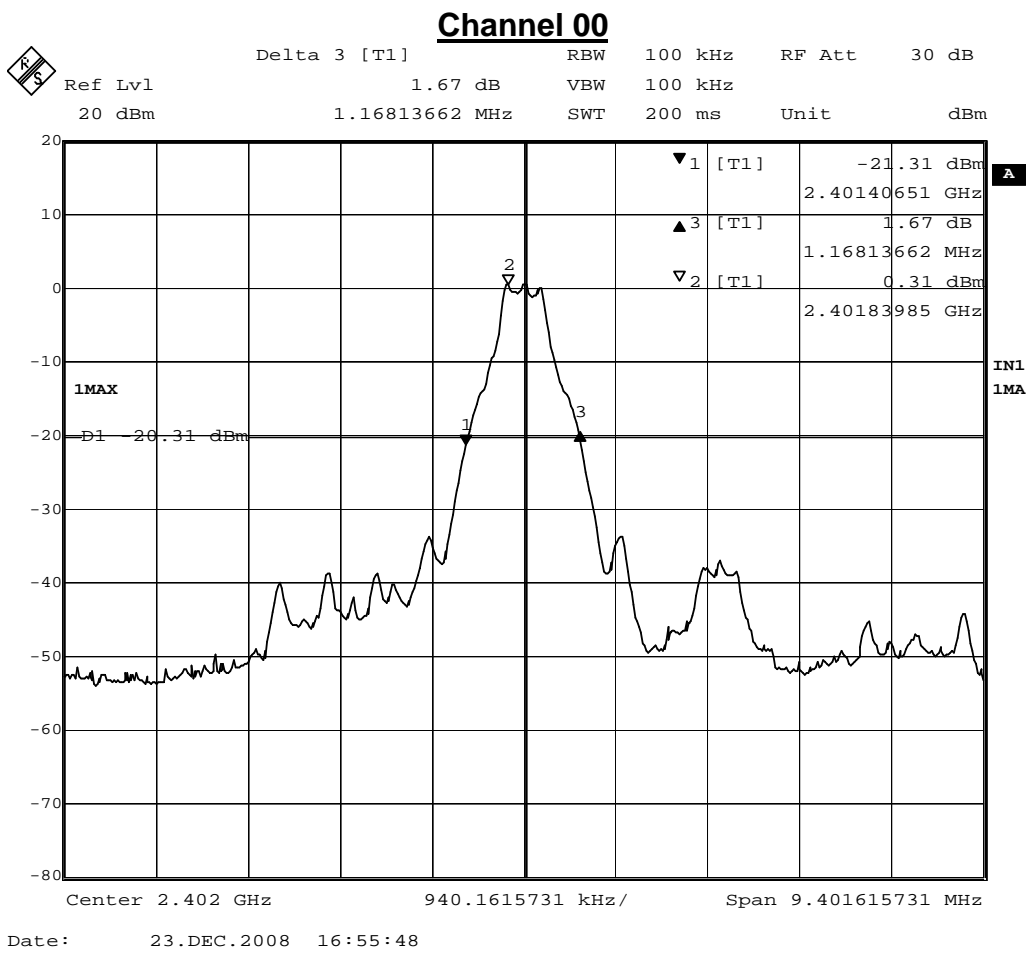

Product	Conference Phone		
Test Item	Occupied Bandwidth		
Test Mode	Transmit		
Date of Test	2008/12/23	Test Site	No.1 OATS

1M-GFSK Modulation, PRBS Packet Type

Channel No.	Frequency (MHz)	Measure Level (MHz)	Limit (MHz)	Result
39	2441.00	1.2058	--	Pass

### Channel 39

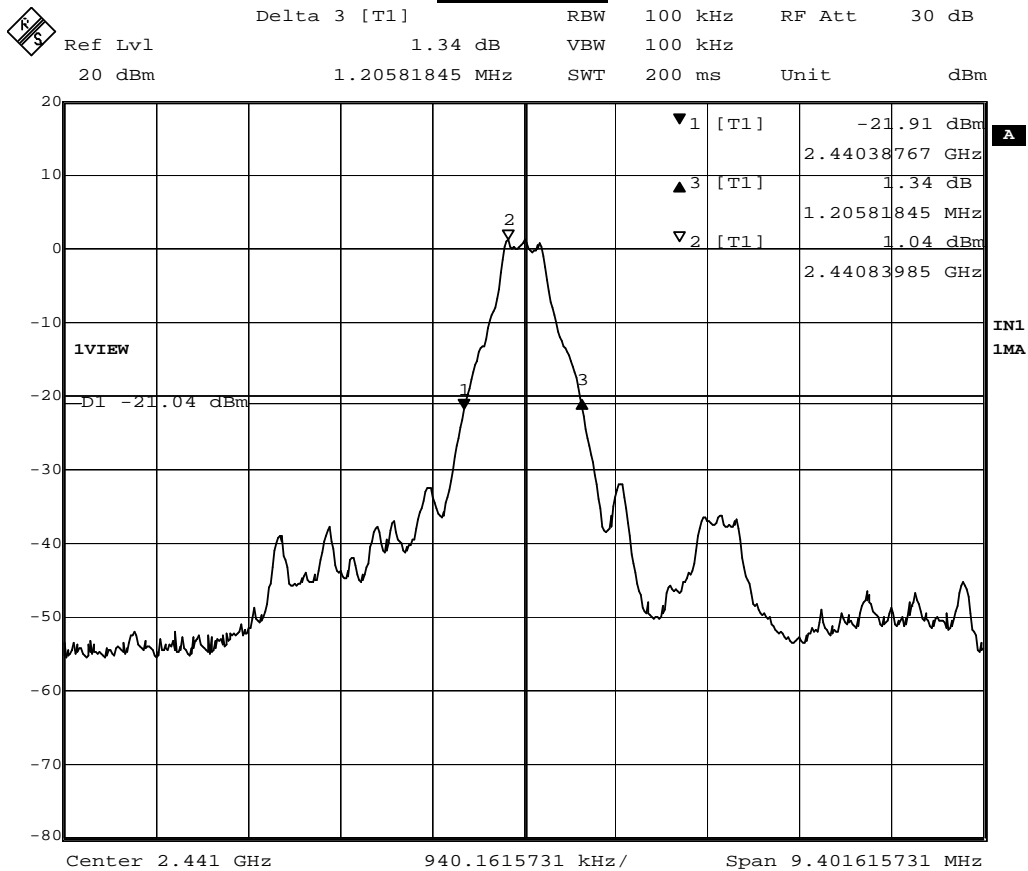

Date: 23.DEC.2008 16:57:56

Product	Conference Phone		
Test Item	Occupied Bandwidth		
Test Mode	Transmit		
Date of Test	2008/12/23	Test Site	No.1 OATS

1M-GFSK Modulation, PRBS Packet Type

Channel No.	Frequency (MHz)	Measure Level (MHz)	Limit (MHz)	Result
78	2480.00	1.1492	--	Pass

### Channel 78

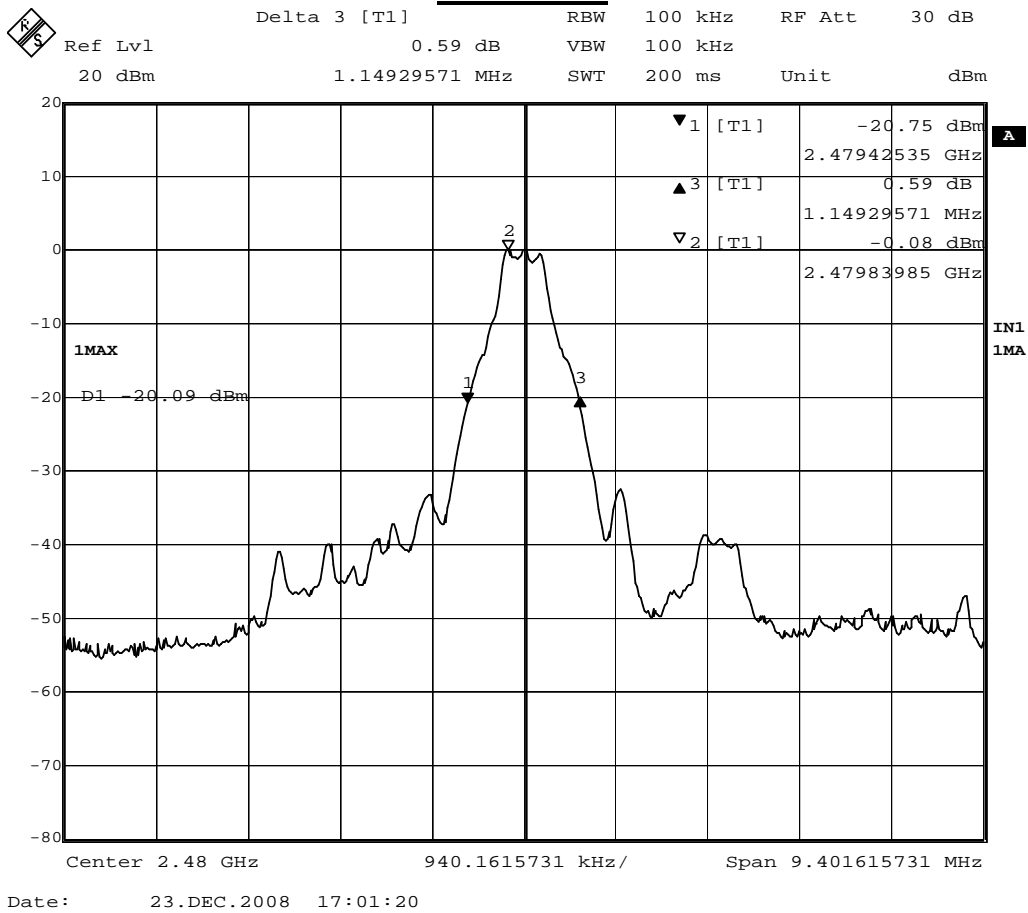

**10. Dwell Time**

**10.1. Test Equipment**

The following test equipment are used during the test:

Item	Equipment	Manufacturer	Model No. / Serial No.	Last Cal.
1	Spectrum Analyzer	R & S	FSP / 100561	Mar., 2008
2	No.1 OATS			Sep., 2008

Note: 1. All equipments that need to calibrate are with calibration period of 1 year.

**10.2. Test Setup**

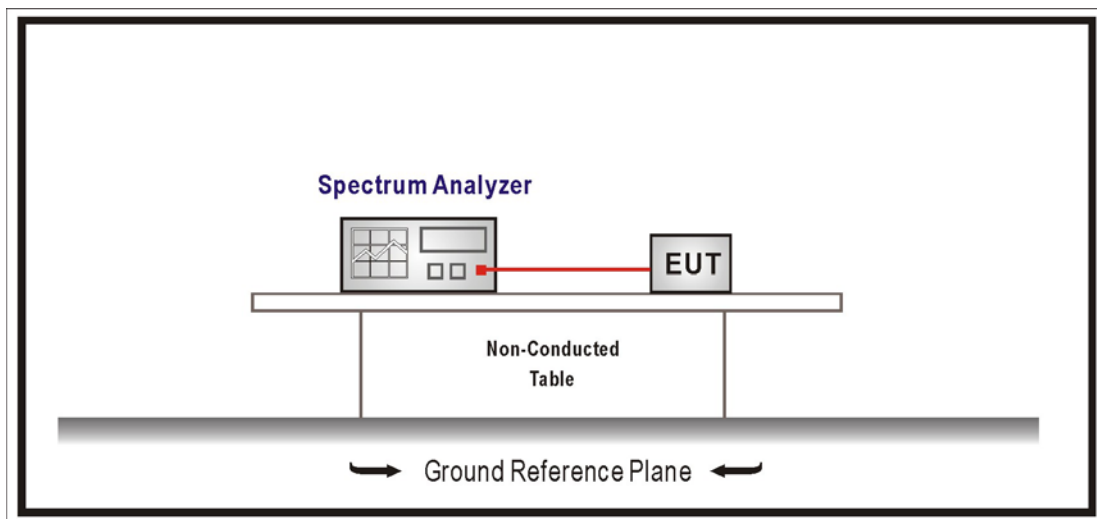

**10.3. Limits**

For frequency hopping systems operating in the 902-928 MHz band: if the 20 dB bandwidth of the hopping channel is less than 250 kHz, the system shall use at least 50 hopping frequencies and the average time of occupancy on any frequency shall not be greater than 0.4 seconds within a 20 second period; if the 20 dB bandwidth of the hopping channel is 250 kHz or greater, the system shall use at least 25 hopping frequencies and the average time of occupancy on any frequency shall not be greater than 0.4 seconds within a 10 second period. For frequency hopping systems operating in the 2400-2483.5 MHz bands. The average time of occupancy on any channel shall not be greater than 0.4 seconds within a period of 0.4 seconds multiplied by the number of hopping channels employed. For frequency hopping systems operating in the 5725-5850 MHz bands. The average time of occupancy on any frequency shall not be greater than 0.4 seconds within a 30 second period.

**10.4. Test Procedures**

The EUT was setup according to ANSI C63.4, 2003 and tested according to FHSS test procedure of FCC Public Notice DA 00-705 for compliance to FCC 47CFR 15.247 requirements

Span = zero span, centered on a hopping channel

RBW = 1 MHz, VBW ≥ RBW

Sweep = as necessary to capture the entire dwell time per hopping channel

Detector function = peak, Trace = max hold

**10.5. Test Specification**

According to FCC Part 15 Subpart C Paragraph 15.247: 2008



10.6. Test Result

Product	Conference Phone		
Test Item	Dwell Time		
Test Mode	Transmit		
Date of Test	2008/12/24	Test Site	No.1 OATS

Occupancy Time of Frequency Hopping System

A) 2402MHz Test Time Period:  $0.4 \times 79 = 31.6\text{sec}$  · Hopping Times Within 1sec:  $5/20\text{msec} = 250 / \text{sec}$

The Maximum Occupancy Time Within 31.6sec:  $0.00342 \times (250/79) \times 31.6 = 0.342\text{sec}$  ◦

B) 2441MHz Test Time Period:  $0.4 \times 79 = 31.6\text{sec}$  · Hopping Times Within 1sec:  $5/20\text{msec} = 250 / \text{sec}$

The Maximum Occupancy Time Within 31.6sec:  $0.00362 \times (250/79) \times 31.6 = 0.362\text{sec}$  ◦

C) 2480MHz Test Time Period:  $0.4 \times 79 = 31.6\text{sec}$  · Hopping Times Within 1sec:  $5/20\text{msec} = 250 / \text{sec}$

The Maximum Occupancy Time Within 31.6sec:  $0.00308 \times (250/79) \times 31.6 = 0.308\text{sec}$  ◦

Test Result: The Average Occupancy Time of Each Highest · Middle and Lowest Channel Is Less Than 0.4sec · And Corresponds to The Standard ◦

**Hop rate-2402MHz**

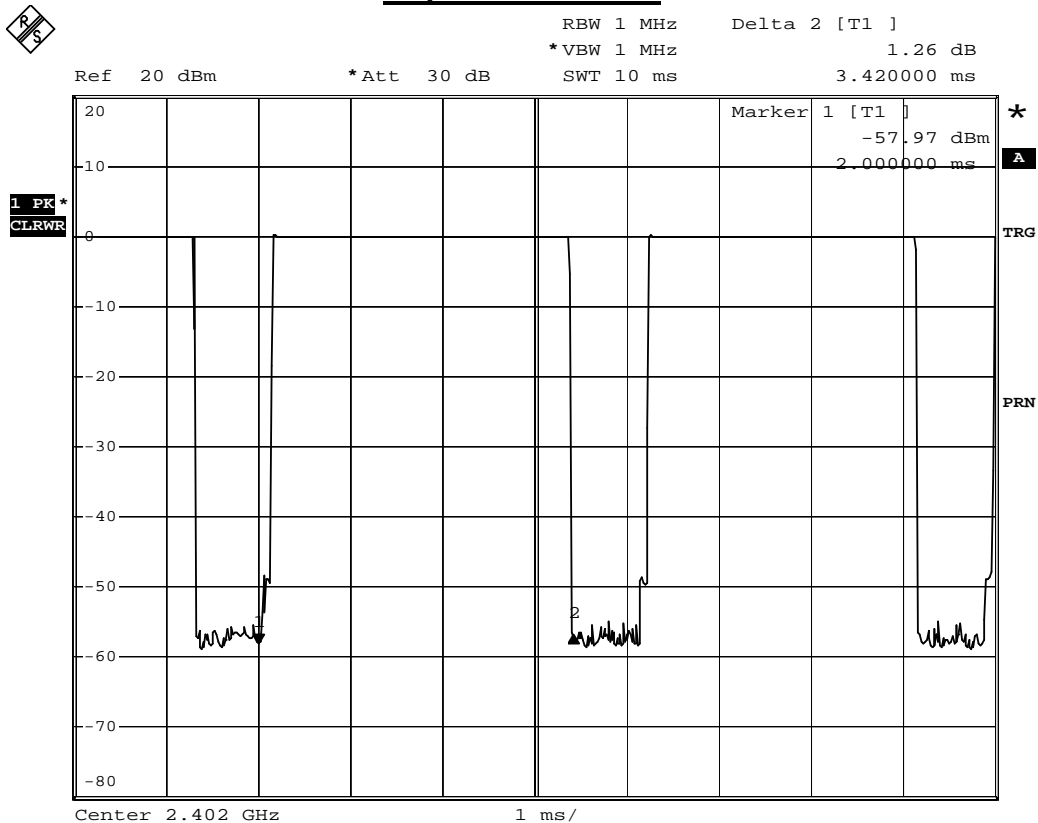

Date: 24.DEC.2008 16:10:00

**Hop rate-2441MHz**

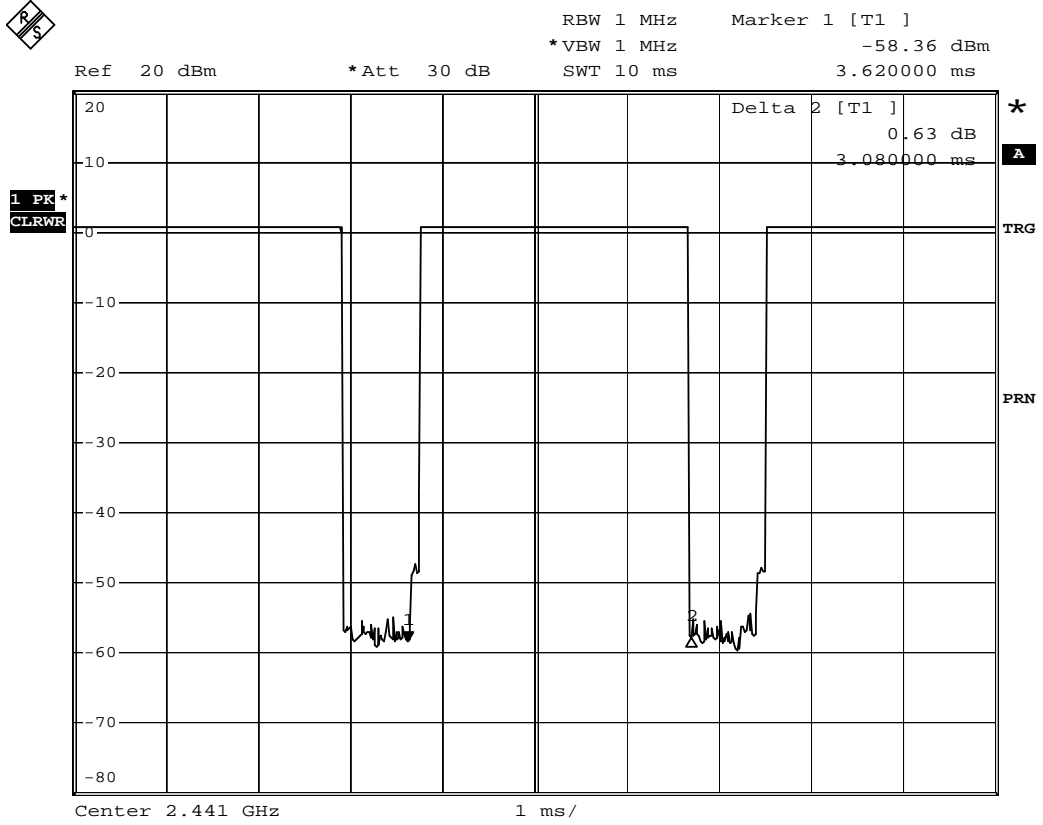

Date: 24.DEC.2008 16:11:09

**Hop rate-2480MHz**

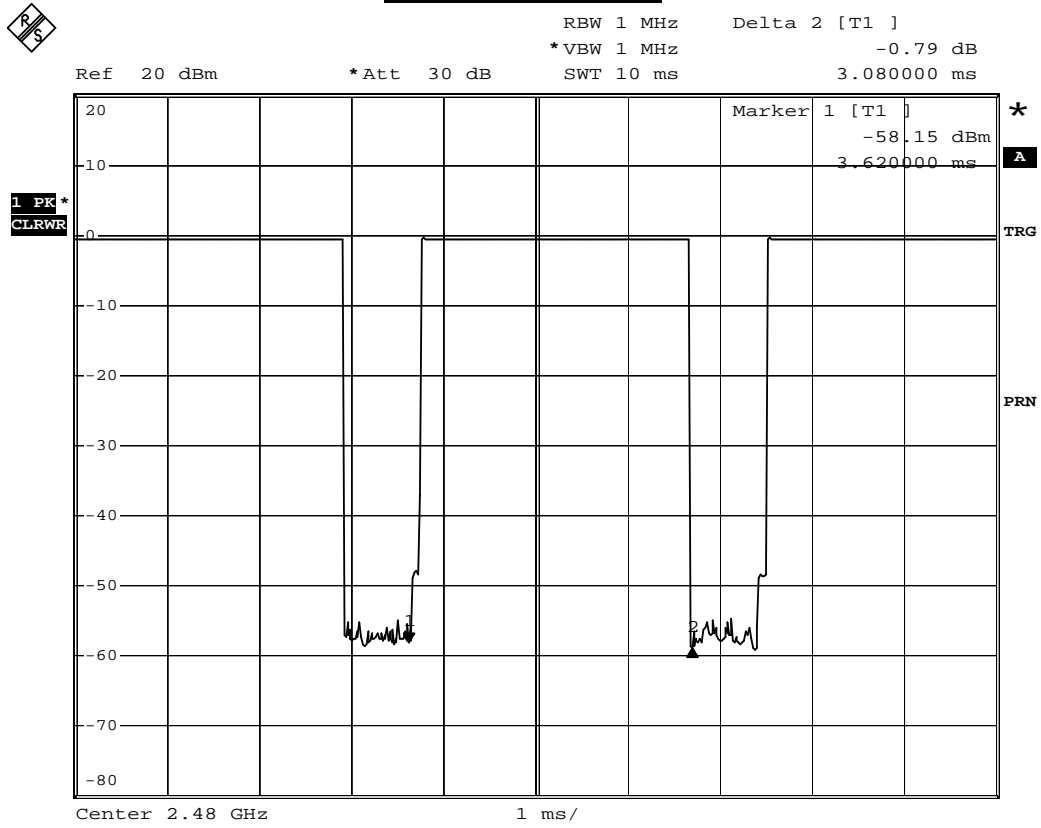

Date: 24.DEC.2008 16:12:04

Note: Dwell time = time slot length \* hop rate / number of hopping channels \* period

### Time slot length



RBW 1 MHz  
\*VBW 1 MHz

Ref 20 dBm      \*Att 30 dB      SWT 20 ms

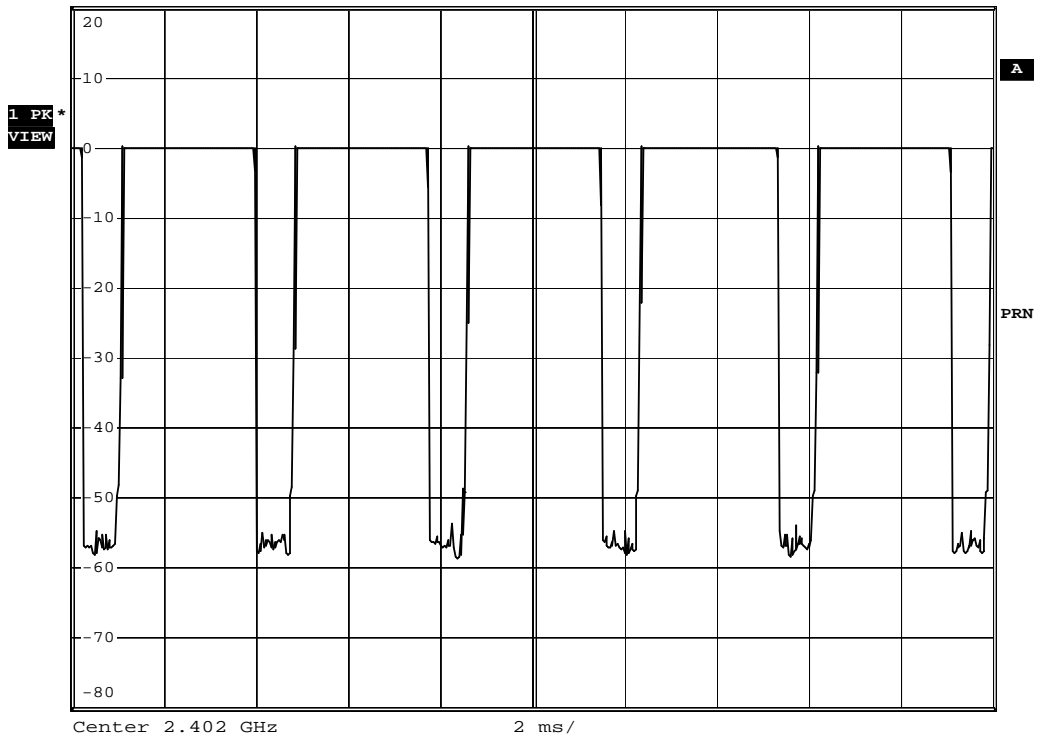

Date: 24.DEC.2008 16:08:52