

Test Report

Report Number:

F161000E2

Equipment under Test (EUT):

SmartSample

Applicant:

Mettler-Toledo GmbH

Manufacturer:

Mettler-Toledo GmbH





Deutsche
Akkreditierungsstelle
D-PL-17186-01-01
D-PL-17186-01-02
D-PL-17186-01-03

References

- [1] **ANSI C63.10: 2013** American National Standard of Procedures for Compliance Testing of Unlicensed Wireless Devices
- [2] **FCC CFR 47 Part 15 (October 2015)** Radio Frequency Devices
- [3] **RSS-210 Issue 9 (August 2016)** Licence-exempt Radio Apparatus: Category I Equipment
- [4] **RSS-Gen Issue 4 (November 2014)** General Requirements for Compliance of Radio Apparatus

Test result

The requirements of the tests performed as shown in the overview (chapter 4 of this test report) were fulfilled by the equipment under test.
The complete test results are presented in the following.

Test engineer:	Thomas KÜHN		11/09/2016
	Name	Signature	Date
Authorized reviewer:	Bernd STEINER		11/09/2016
	Name	Signature	Date

This test report is only valid in its original form.

Any reproduction of its contents in extracts without written permission of the accredited test laboratory PHOENIX TESTLAB GmbH is prohibited.

The test results herein refer only to the tested sample. PHOENIX TESTLAB GmbH is not responsible for any generalisations or conclusions drawn from these test results concerning further samples. Any modification of the tested samples is prohibited and leads to the invalidity of this test report. Each page necessarily contains the PHOENIX TESTLAB Logo and the TEST REPORT NUMBER.

This test report is valid in hardcopy form as well as in electronic form.

Contents:	Page
1 Identification	4
1.1 Applicant	4
1.2 Manufacturer	4
1.3 Test Laboratory	4
1.4 EUT (Equipment Under Test)	5
1.5 Technical data of equipment	5
1.6 Dates	5
2 Operational states and test setup	6
3 Additional information	7
4 Overview	7
5 Results	8
5.1 Conducted emissions on power supply lines (150 kHz to 30 MHz)	8
5.1.1 Method of measurement	8
5.1.2 Test results (conducted emissions on power supply lines)	9
5.2 Radiated emissions	10
5.2.1 Method of measurement (radiated emissions)	10
5.2.2 Results preliminary measurement 9 kHz to 1 GHz	17
5.2.3 Result final measurement from 9 kHz to 30 MHz	19
5.2.4 Result final measurement from 30 MHz to 1 GHz	20
5.3 99 % bandwidth	22
5.3.1 Method of measurement	22
5.3.2 Test results	23
6 Test equipment	24
7 Report history	25
8 List of annexes	25

1 Identification

1.1 Applicant

Name:	Mettler-Toledo GmbH
Address:	Im Langacher 44 CH-8606 Greifensee
Country:	Switzerland
Name for contact purposes:	Mr. David KRESS
Phone:	+41 44 944 23 84
eMail Address:	David.Kress@mt.com
Applicant represented during the test by the following person:	-

1.2 Manufacturer

Name:	Mettler-Toledo GmbH
Address:	Im Langacher 44 CH-8606 Greifensee
Country:	Switzerland
Name for contact purposes:	Mr. David KRESS
Phone:	+41 44 944 23 84
eMail Address:	David.Kress@mt.com
Manufacturer represented during the test by the following person:	-

1.3 Test Laboratory

The tests were carried out at:

PHOENIX TESTLAB GmbH
Königswinkel 10
32825 Blomberg
Germany

accredited by Deutsche Akkreditierungsstelle GmbH (DAkKS) in compliance with DIN EN ISO/IEC 17025 under Reg. No. D-PL-17186-01-02, FCC Test Firm Accreditation with the registration number 469623, designation number DE0004 and Industry Canada Test site registration SITE# IC3469A-1.

1.4 EUT (Equipment Under Test)

Type object: *	RFID Reader
Model name / HVIN: *	SmartSample
Serial No.:	None
FCC ID: *	THVSMARTSAMPLE
IC: *	22032-SMARTSAMPLE
PCB identifier:	30083750 E
Hardware version: *	N.a.
Software version: *	N.a.
Lowest internal frequency: *	13.56 MHz
Highest internal frequency: *	13.56 MHz

1.5 Technical data of equipment

Channel 1	RX:	13.56 MHz	TX:	13.56 MHz		
Rated RF output power: *	<1 μ W					
Antenna type: *	PCB antenna with 0.0038m ² (13.56 MHz)					
Number of channels: *	1					
Antenna connector: *	None					
Modulation: *	ASK					
Data rate: *	5.2 kbit/s					
Supply voltage: *	U _{Nom} =	230 V _{AC}	U _{Min} =	90 V _{AC}	U _{Max} =	264 V _{AC}
Power supply: *	External by EasyScan Module					
Temperature range: *	0 °C to 40 °C					
Ancillary used for test:	EasyScan Module powered by PASC30U-120 (dedicated AC/DC adaptor)					

*: declared by the applicant.

Ports / Connectors			
Identification	Connector		Length during test
	EUT	Ancillary	
Connection line	Fixed	USB 1.0 type A	20 cm
-	-	-	-
-	-	-	-

1.6 Dates

Date of receipt of test sample:	07/13/2016
Start of test:	07/14/2016
End of test:	08/03/2016

2 Operational states and test setup

The EUT is a RFID reader for weighting systems. As declared by the applicant, it will always be connected to an EasyScan Module, which will be used with a dedicated AC/DC adaptor type PASC30U-120.

The connection line of the EUT is equipped with an USB type A connector. The applicant declared that this connection is no USB connection, only a USB connector is used. The EUT is not able to operate on an USB port, it will allways require an connection to the EasyScan Module.

During all measurements a 13.56 MHz TAG was positioned in front of the EUT and the EUT was powered via the EasyScan Module, which was powered with 12 V_{DC} by the dedicated AC/DC adaptor.

All measurements were carried out with an unmodified sample operating in a test mode. The test mode was entered with the help of a test-software running on a laptop PC, which is connected to EUT via the RS 232 interface of the EasyScan Module. With this test mode the TAG data were cyclic read and the TAG was written. The RS232 connection between the EUT and the laptop PC was set up with the help of two fibre optics to RS232 converter.

Physical boundaries of the Equipment Under Test

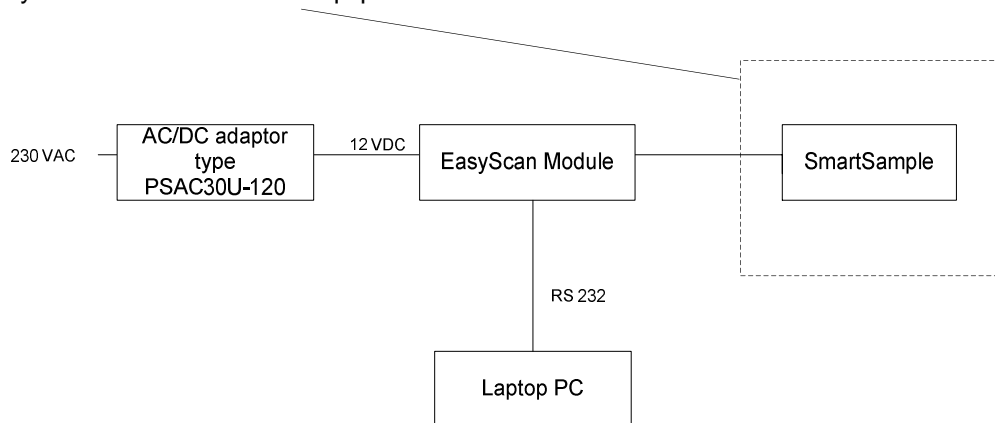

3 Additional information

The EUT was not labeled as required by FCC / IC.

4 Overview

Application	Frequency range [MHz]	FCC 47 CFR Part 15 section [2]	RSS-Gen, Issue 4 [4] and RSS 210, Issue 9 [3]	Status	Refer page
Conducted emissions on supply line	0.15 – 30	15.207	8.8 [4]	Passed	8 et seq.
Radiated emissions	1 – 1,000	15.205 15.209	8.9 [4] 4.4 [3]	Passed	10 et seq.
99 % bandwidth	13.56	-	6.6 [4]	-	22 et seq.
Antenna requirement	-	15.203	-	Passed *	-

*: Integrated antenna only, requirement fulfilled.

5 Results

5.1 Conducted emissions on power supply lines (150 kHz to 30 MHz)

5.1.1 Method of measurement

This test will be carried out in a shielded chamber. Tabletop devices will set up on a non-conducting support with a size of 1 m by 1.5 m and a height of 80 cm above the ground plane. Floor-standing devices will be placed directly on the ground plane. The setup of the Equipment under test will be in accordance to [1].

The frequency range 150 kHz to 30 MHz will be measured with an EMI Receiver set to MAX Hold mode with peak and average detector and a resolution bandwidth of 9 kHz. A scan will be carried out on the phase (or plus pole in case of DC powered devices) of the AC mains network. If levels detected 10 dB below the appropriate limit, this emission will be measured with the average and quasi-peak detector on all lines.

Frequency range	Resolution bandwidth
150 kHz to 30 MHz	9 kHz

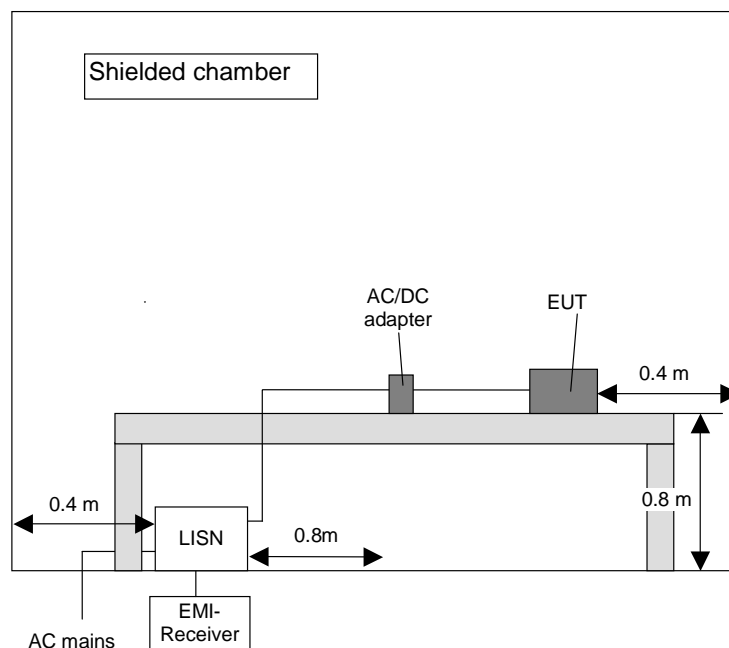

5.1.2 Test results (conducted emissions on power supply lines)

Ambient temperature	22 °C	Relative humidity	38 %
---------------------	-------	-------------------	------

Position of EUT: The EUT was set-up on a non-conducting table of a height of 0.8 m.

Cable guide: The cables of the EUT and the ancillary were fixed on the non-conducting table. For further information of the cable guide refer to the pictures in annex A of this test report.

Test record: The test was carried out in TAG reading and writing mode of the EUT (refer also clause 2 of this test report). All results are shown in the following.

Supply voltage: During this test the EUT was powered via the EasyScan Module, which was powered with 12 V_{AC} by the PASC30U-120, which was itself supplied with 120 V_{AC} / 60 Hz.

The curves in the diagram only represent for each frequency point the maximum measured value of all preliminary measurements which were made for each power supply line. The top measured curve represents the peak measurement and the bottom measured curve the average measurement. The quasi-peak measured points are marked by **◆** and the average measured points by **+**.

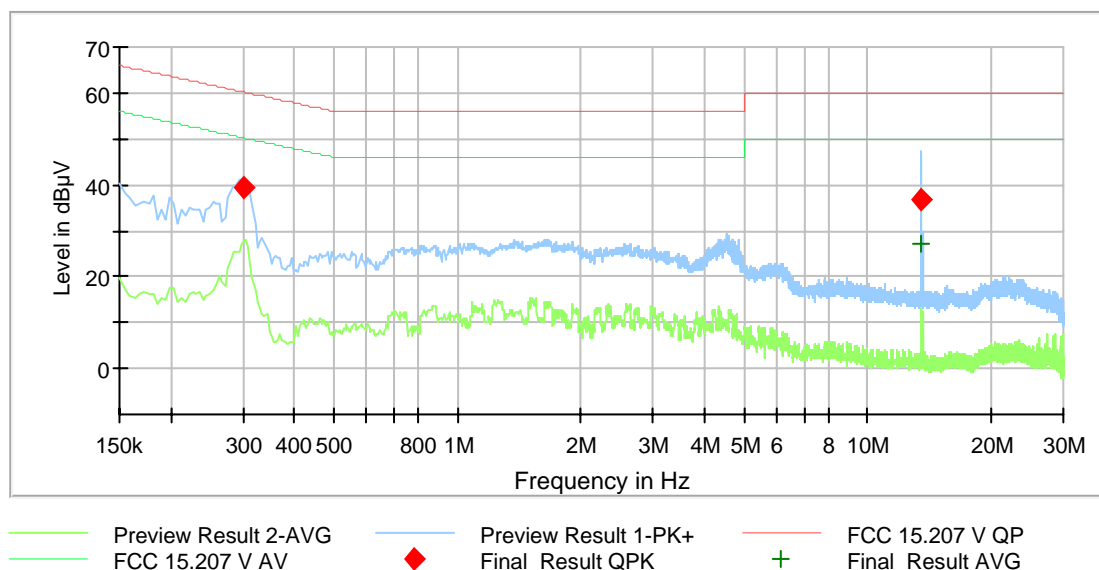

Data record name: 161000AC

Remark: The limits of FCC 15.207 are identical to [3]

Frequency (MHz)	QuasiPeak (dBµV)	Average (dBµV)	Limit (dBµV)	Margin (dB)	Meas. Time (ms)	Bandwidth (kHz)	Line	PE	Transducer (dB)
0.301200	39.2	---	60.2	21.0	5000.0	9.000	L1	GND	9.9
13.563600	---	27.1	50.0	22.9	5000.0	9.000	L1	FLO	10.7
13.564500	36.8	---	60.0	23.2	5000.0	9.000	L1	GND	10.7
Measurement uncertainty					+6.7 dB / -6.0 dB				

Test: Passed

Test equipment used (see chapter 6):

1 - 4, 6

5.2 Radiated emissions

5.2.1 Method of measurement (radiated emissions)

The radiated emission measurement is subdivided into six stages.

- A preliminary measurement carried out in a fully anechoic chamber with a fixed antenna height in the frequency range 9 kHz to 1 GHz.
- A final measurement carried out on an outdoor test site without reflecting ground plane and a fixed antenna height in the frequency range 9 kHz to 30 MHz.
- A preliminary measurement carried out in a fully anechoic chamber with a fixed antenna height in the frequency range 30 MHz to 1 GHz.
- A final measurement carried out on an open area test site with reflecting ground plane and various antenna heights in the frequency range 30 MHz to 1 GHz.
- A preliminary measurement carried out in a fully anechoic chamber with a fixed antenna height in the frequency range 1 GHz to 5 GHz.
- A final measurement carried out in a fully anechoic chamber with a fixed antenna height in the frequency range 1 GHz to 5 GHz.

Preliminary measurement (9 kHz to 30 MHz):

In the first stage a preliminary measurement will be performed in a shielded room with a measuring distance of 3 meters. Table-top devices will set up on a non-conducting support with a size of 1 m by 1.5 m and a height of 80 cm. Floor-standing devices will be placed directly on the turntable/ground plane. The set up of the Equipment under test will be in accordance to [1].

The frequency range 9 kHz to 30 MHz will be monitored with a spectrum analyser while the system and its cables will be manipulated to find out the configuration with the maximum emission levels if applicable. The EMI Receiver will be set to MAX Hold mode. The EUT and the measuring antenna will be rotated around their vertical axis to found the maximum emissions.

The resolution bandwidth of the spectrum analyser will be set to the following values:

Frequency range	Resolution bandwidth
9 kHz to 150 kHz	200 Hz
150 kHz to 30 MHz	10 kHz

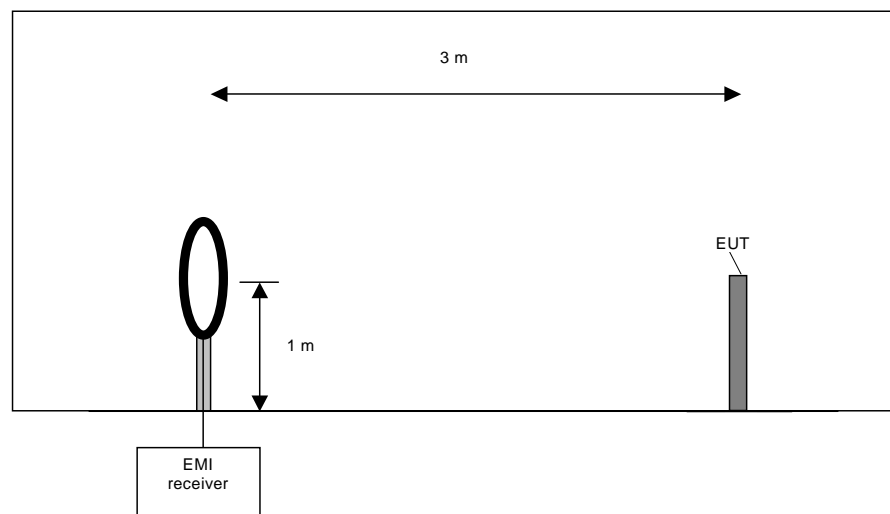

Preliminary measurement procedure:

Prescans were performed in the frequency range 9 kHz to 150 kHz and 150 kHz to 30 MHz.

The following procedure will be used:

- 1) Monitor the frequency range at horizontal polarisation and a EUT azimuth of 0 °.
- 2) Manipulate the system cables within the range to produce the maximum level of emission.
- 3) Rotate the EUT by 360 ° to maximize the detected signals.
- 4) Make a hardcopy of the spectrum.
- 5) Measure the frequencies of highest detected emission with a lower span and resolution bandwidth to increase the accuracy and note the frequency value.
- 6) Repeat steps 1) to 5) with the other orthogonal axes of the EUT (because of EUT is a module and might be used in a handheld equipment application).
- 7) Rotate the measuring antenna and repeat steps 1) to 5).

Final measurement (9 kHz to 30 MHz):

In the second stage a final measurement will be performed on an open area test site with no conducting ground plane in a measuring distances of 3 m, 10 m and 30 m. In the case where larger measuring distances are required the results will be extrapolated based on the values measured on the closer distances according to Section 15.31 (f) (2) [2]. The final measurement will be performed with a EMI Receiver set to Quasi Peak detector except for the frequency bands 9 kHz to 90 kHz and 110 kHz to 490 kHz where an average detector will be used according Section 15.209 (d) [2].

On the frequencies, which were detected during the preliminary measurements, the final measurement will be performed while rotating the EUT and the measuring antenna in the range of 0 ° to 360 ° around their vertical axis until the maximum value is found.

The resolution bandwidth of the EMI Receiver will be set to the following values:

Frequency range	Resolution bandwidth
9 kHz to 150 kHz	200 Hz
150 kHz to 30 MHz	9 kHz

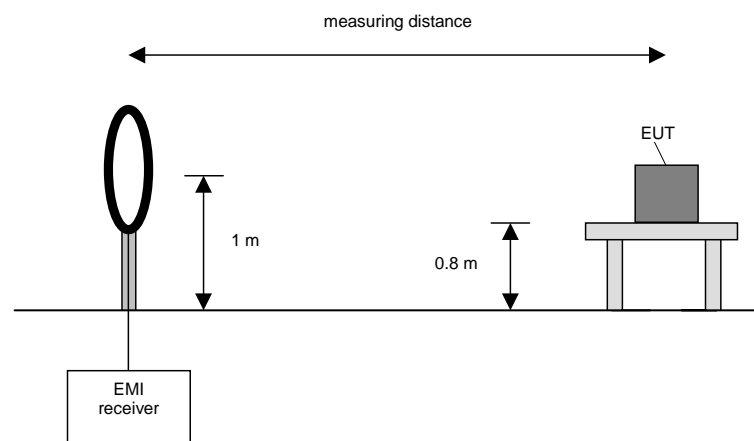

Final measurement procedure:

The following procedure will be used:

- 1) Monitor the frequency range with the measuring antenna at vertical orientation parallel to the EUT at an azimuth of 0 °.
- 2) Rotate the EUT by 360 ° to maximize the detected signals and note the azimuth and orientation.
- 3) Rotate the measuring antenna to find the maximum and note the value.
- 4) Rotate the measuring antenna and repeat steps 1) to 3) until the maximum value is found.
- 5) Repeat steps 1) to 4) with the other orthogonal axes of the EUT (if the EUT is a module and might be used in a handheld equipment application).

Preliminary measurement (30 MHz to 1 GHz)

In the first stage a preliminary measurement will be performed in a fully anechoic chamber with a measuring distance of 3 meter. Tabletop devices will set up on a non-conducting support with a size of 1 m by 1.5 m and a height of 80 cm. Floor-standing devices will be placed directly on the turntable/ground plane. The set up of the Equipment under test will be in accordance to [1].

The frequency range 30 MHz to 1 GHz will be measured with an EMI Receiver set to MAX Hold mode and a resolution bandwidth of 120 kHz. The measurement will be performed in horizontal and vertical polarisation of the measuring antenna and while rotating the EUT in its vertical axis in the range of 0 ° to 360 °.

The resolution bandwidth of the EMI Receiver will be set to the following values:

Frequency range	Resolution bandwidth
30 MHz to 1 GHz	120 kHz

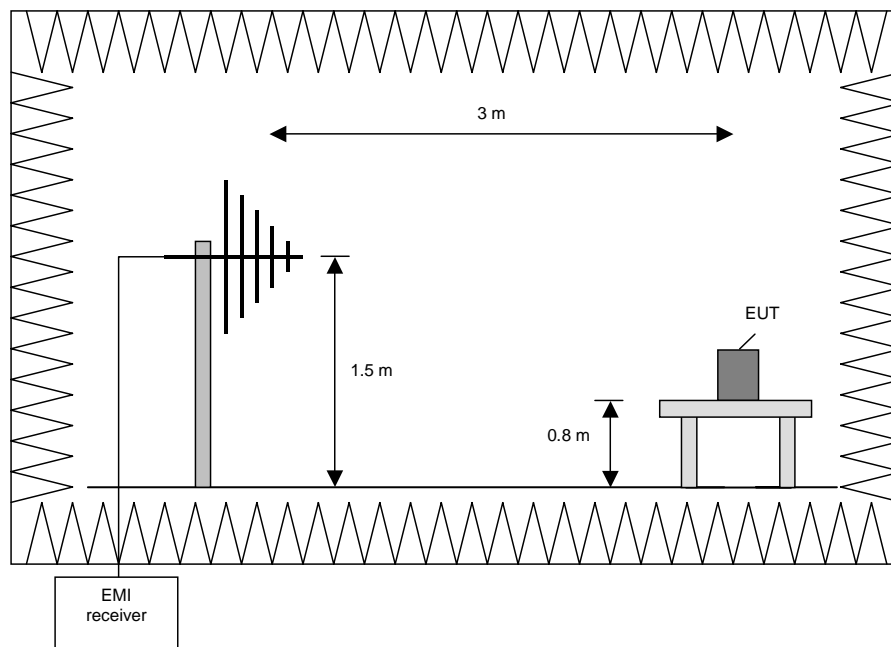

Procedure preliminary measurement:

Prescans were performed in the frequency range 30 MHz to 1 GHz.

The following procedure will be used:

1. Monitor the frequency range at horizontal polarisation and a EUT azimuth of 0 °.
2. Manipulate the system cables within the range to produce the maximum level of emission.
3. Rotate the EUT by 360 ° to maximize the detected signals.
4. Make a hardcopy of the spectrum.
5. Measure the frequency of the detected emissions with a lower span and resolution bandwidth to increase the accuracy and note the frequency value.
6. Repeat 1) to 4) with the other orthogonal axes of the EUT if handheld equipment.
7. Repeat 1) to 5) with the vertical polarisation of the measuring antenna.

Final measurement (30 MHz to 1 GHz)

A final measurement on an open area test site will be performed on selected frequencies found in the preliminary measurement. During this test the EUT will be rotated in the range of 0 ° to 360 °, the measuring antenna will be set to horizontal and vertical polarisation and raised and lowered in the range from 1 m to 4 m to find the maximum level of emissions.

The resolution bandwidth of the EMI Receiver will be set to the following values:

Frequency range	Resolution bandwidth
30 MHz to 1 GHz	120 kHz

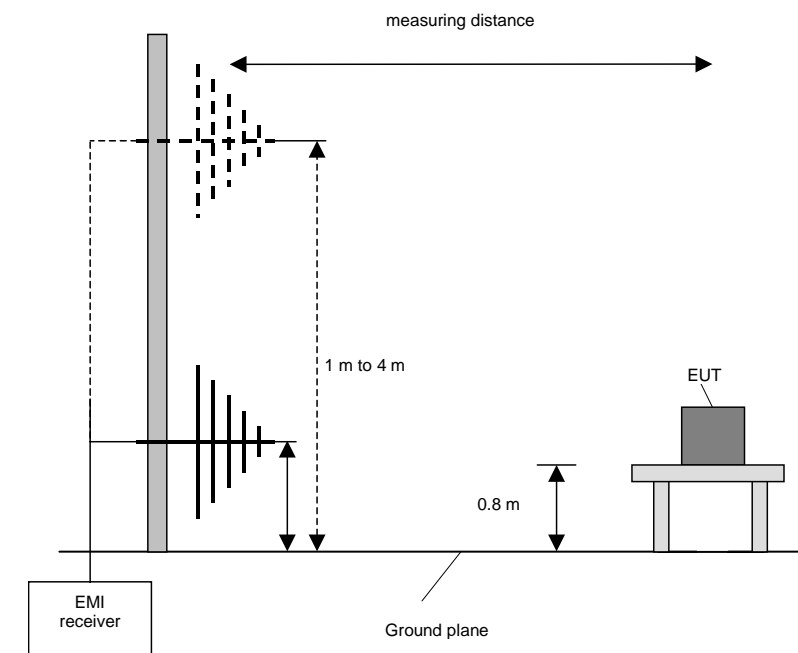

Procedure final measurement:

The following procedure will be used:

- 1) Measure on the selected frequencies at an antenna height of 1 m and a EUT azimuth of 23 °.
- 2) Move the antenna from 1 m to 4 m and note the maximum value at each frequency.
- 3) Rotate the EUT by 45 ° and repeat 2) until an azimuth of 337 ° is reached.
- 4) Repeat 1) to 3) for the other orthogonal antenna polarization.
- 5) Move the antenna and the turntable to the position where the maximum value is detected.
- 6) Measure while moving the antenna slowly +/- 1 m.
- 7) Set the antenna to the position where the maximum value is found.
- 8) Measure while moving the turntable +/- 45 °.
- 9) Set the turntable to the azimuth where the maximum value is found.
- 10) Measure with Final detector (QP and AV) and note the value.
- 11) Repeat 5) to 10) for each frequency.
- 12) Repeat 1) to 11) for each orthogonal axes of the EUT if handheld equipment.

Preliminary and final measurement (1 GHz to 110 GHz)

This measurement will be performed in a fully anechoic chamber. Table top devices will set up on a non-conducting turn device on the height of 1.5 m. The set-up of the Equipment under test will be in accordance to [1].

Preliminary measurement (1 GHz to 40 GHz)

The frequency range will be divided into different sub ranges depending of the frequency range of the used horn antenna. The spectrum analyser set to MAX Hold mode and a resolution bandwidth of 100 kHz. The measurement will be performed in horizontal and vertical polarisation of the measuring antenna and while rotating the EUT in its vertical axis in the range of 0 ° to 360 °. This measurement is repeated after raising the EUT in 30 ° steps according 6.6.5.4 in [1].

The resolution bandwidth of the EMI Receiver will be set to the following values:

Frequency range	Resolution bandwidth
1 GHz to 4 GHz	1 MHz
4 GHz to 12 GHz	1 MHz
12 GHz to 18 GHz	1 MHz
18 GHz to 26.5 GHz	1 MHz
26.5 GHz to 40 GHz	1 MHz
40 GHz to 60 GHz	1 MHz
50 GHz to 75 GHz	1 MHz
75 GHz to 110 GHz	1 MHz

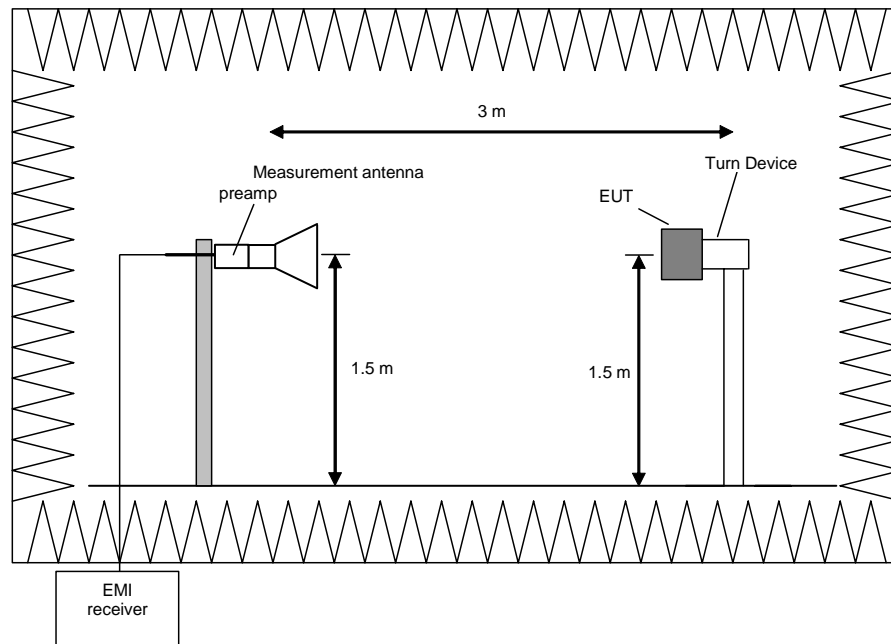

Procedure preliminary measurement:

Prescans were performed in the frequency range 1 to 40 GHz.

The following procedure will be used:

1. Monitor the frequency range at horizontal polarisation and a EUT azimuth of 0 °.
2. Rotate the EUT by 360° to maximize the detected signals.
3. Repeat 1) to 2) with the vertical polarisation of the measuring antenna.
4. Make a hardcopy of the spectrum.
5. Repeat 1) to 4) with the EUT raised by an angle of 30° (60°, 90°, 120° and 150°) according to 6.6.5.4 in [1].
6. Measure the frequency of the detected emissions with a lower span and resolution bandwidth to increase the accuracy and note the frequency value.
7. The measurement antenna polarisation, with the according EUT position (Turntable and Turn device) which produces the highest emission for each frequency will be used for the final measurement. The six closest values to the applicable limit will be used for the final measurement.

Final measurement (1 GHz to 110 GHz)

The frequency range will be divided into different sub ranges depending of the frequency range of the used antenna. The EMI Receiver set to peak and average mode and a resolution bandwidth of 1 MHz. The measurement will be performed by rotating the turntable through 0 to 360° in the worst-case EUT orientation which was obtained during the preliminary measurements.

The resolution bandwidth of the EMI Receiver will be set to the following values:

Frequency range	Resolution bandwidth
1 GHz to 4 GHz	1 MHz
4 GHz to 12 GHz	1 MHz
12 GHz to 18 GHz	1 MHz
18 GHz to 26.5 GHz	1 MHz
26.5 GHz to 40 GHz	1 MHz
40 GHz to 60 GHz	1 MHz
50 GHz to 75 GHz	1 MHz
75 GHz to 110 GHz	1 MHz

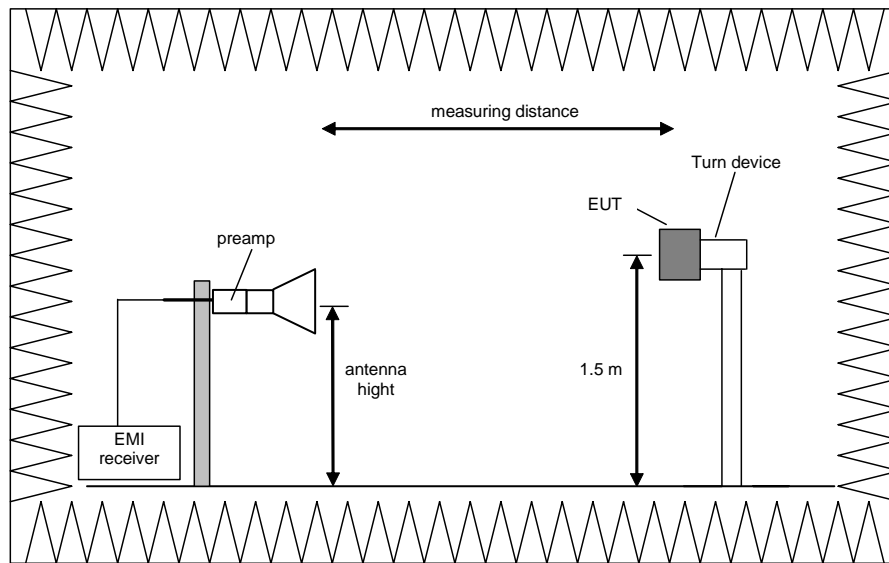

Procedure of measurement:

The measurements were performed in the frequency range 1 GHz to 110 GHz.

The following procedure will be used:

- 1) Set the turntable and the turn device to obtain the worst-case emission for the first frequency identified in the preliminary measurements.
- 2) Set the measurement antenna polarisation to the orientation with the highest emission for the first frequency identified in the preliminary measurements.
- 3) Set the spectrum analyser to EMI mode with peak and average detector activated.
- 4) Rotate the turntable from 0° to 360° to find the EUT angle that produces the highest emissions.
- 5) Note the highest displayed peak and average values
- 6) Repeat the steps 1) to 5) for each frequency detected during the preliminary measurements.

5.2.2 Results preliminary measurement 9 kHz to 1 GHz

Ambient temperature	22 °C	Relative humidity	39 %
---------------------	-------	-------------------	------

- Position of EUT: The EUT was set-up on a non-conducting table.
- Cable guide: The cable of the EUT was fixed on the non-conducting table. For further information of the cable guide refer to the pictures in annex A of this test report.
- Test record: The test was carried out in TAG reading and writing mode of the EUT (refer also clause 2 of this test report). All results are shown in the following.
- Supply voltage: During this test the EUT was powered via the EasyScan Module, which was powered with 12 V_{AC} by the PASC30U-120, which was itself supplied with 120 V_{AC} / 60 Hz.
- Frequency range: According to [2] from 9 kHz to 1 GHz.

161000_108.wmf: Spurious emissions from 1 MHz to 30 MHz

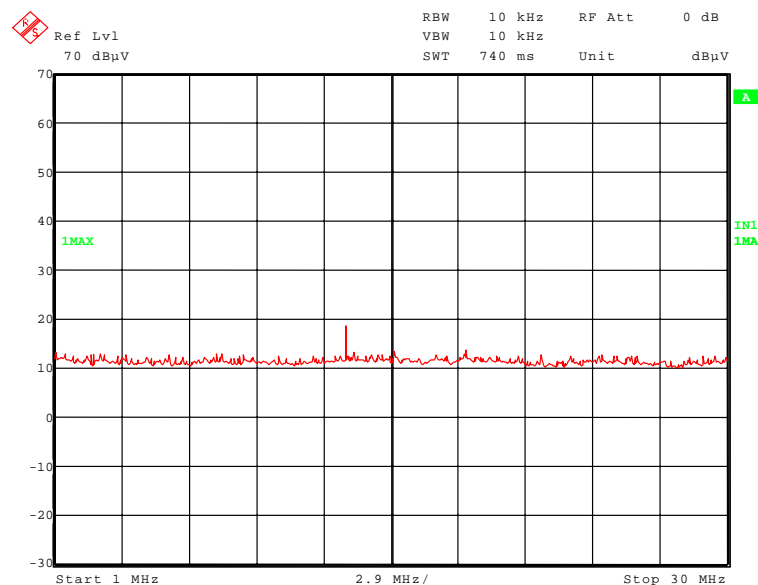

The following emission was found according to [2] and [3].

13.560 MHz.

This frequency has to be measured on the outdoor test site. The result is presented in the following.

161000_109.wmf: Spurious emissions from 30 MHz to 230 MHz

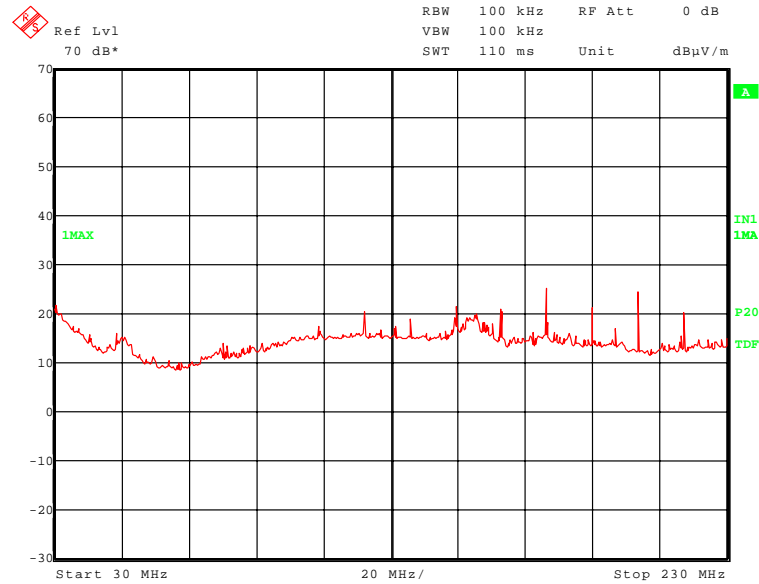

161000_110.wmf: Spurious emissions from 230 MHz to 1 GHz

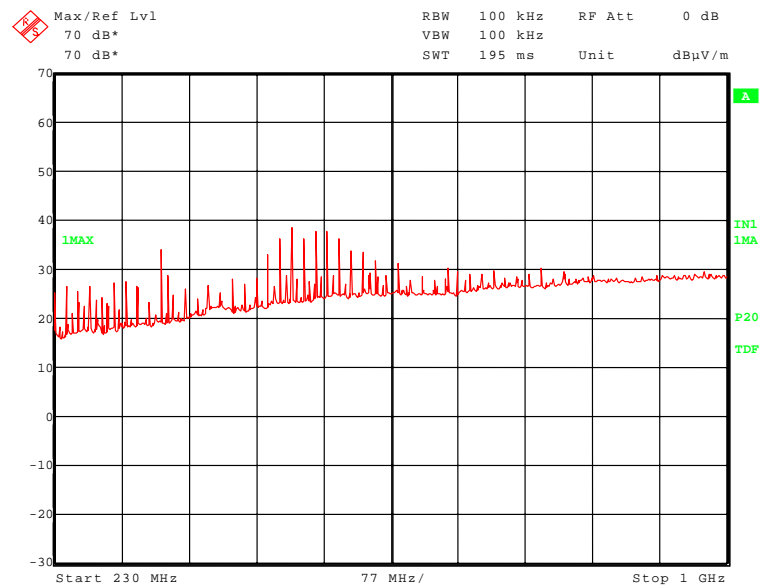

The following frequencies were found outside restricted bands during the preliminary radiated emission test:

- 149.163 MHz, 176.279 MHz, 203.403 MHz, 351.904 MHz, 473.808 MHz, 487.695 MHz, 501.583 MHz, 529.359 MHz, 541.703 MHz, 583.367 MHz, 597.255 MHz and 623.487 MHz.

No frequencies were found inside the restricted bands during the preliminary radiated emission test. These frequencies have to be measured on the open area test site. The results were presented in the following.

Test equipment used (see chapter 6)

30 – 35, 44, 51

5.2.3 Result final measurement from 9 kHz to 30 MHz

Ambient temperature	11 °C	Relative humidity	70 %
---------------------	-------	-------------------	------

- Position of EUT:** The EUT was set-up on a non-conducting table of a height of 0.8 m. The distance between EUT and antenna was 3 m and 10 m.
- Cable guide:** The cable of the EUT was fixed on the non-conducting support. For further information of the cable guide refer to the pictures in annex A of this test report.
- Test record:** The test was carried out in TAG reading and writing mode of the EUT (refer also clause 2 of this test report). All results are shown in the following.
- Supply voltage:** During this test the EUT was powered via the EasyScan Module, which was powered with 12 V_{AC} by the PASC30U-120, which was itself supplied with 120 V_{AC} / 60 Hz.
- Test results:** The test results were calculated with the following formula:

$$\text{Result [dB}\mu\text{V/m]} = \text{reading [dB}\mu\text{V]} + \text{antenna factor [dB/m]}$$

Results with measuring distance of 3 m						
Frequency kHz	Result dB μ V/m	Limit ²⁾ dB μ V/m	Margin dB	Detector	Readings dB μ V	Antenna factor ¹⁾ dB/m
13560	35.5	70.0	34.5	QP	15.5	20.0
Results with measuring distance of 10 m						
Frequency kHz	Result dB μ V/m	Limit ²⁾ dB μ V/m	Margin dB	Detector	Readings dB μ V	Antenna factor ¹⁾ dB/m
-	The signal was below the noise floor of the measuring system at 10 m distance					
Measurement uncertainty: +2.2 dB / -3.6 dB						

¹⁾: Cable loss included

²⁾: Limits according to [2] and [3] extrapolated with a factor of 40 dB/decade according to [2]

Test: Passed

Test equipment used for the test:

31, 51, 53

5.2.4 Result final measurement from 30 MHz to 1 GHz

Ambient temperature	22 °C	Relative humidity	35 %
---------------------	-------	-------------------	------

- Position of EUT: The EUT was setup on a non-conducting table of a height of 0.8 m. The distance between EUT and antenna was 3 m.
- Test record: The test was carried out in TAG reading and writing mode of the EUT (refer also clause 2 of this test report). All results are shown in the following.
- Supply voltage: During this test the EUT was powered via the EasyScan Module, which was powered with 12 V_{AC} by the PASC30U-120, which was itself supplied with 120 V_{AC} / 60 Hz.
- Test results: The test results were calculated with the following formula:

$$\text{Result [dB}\mu\text{V/m]} = \text{reading [dB}\mu\text{V]} + \text{cable loss [dB]} + \text{antenna factor [dB/m]} + 6 \text{ dB}$$

The measured points and the limit line in the following diagrams refer to the standard measurement of the emitted interference in compliance with the above-mentioned standard. The measured points marked with an ◆ are the measured results of the standard final measurement on the open area test site.

The results of the standard subsequent measurement on the open area test site are indicated in the table below. The limits as well as the measured results (levels) refer to the above mentioned standard while taking account of the specified requirements for a 3 m measuring distance.

The measurement time with the quasi-peak measuring detector is 5 seconds.

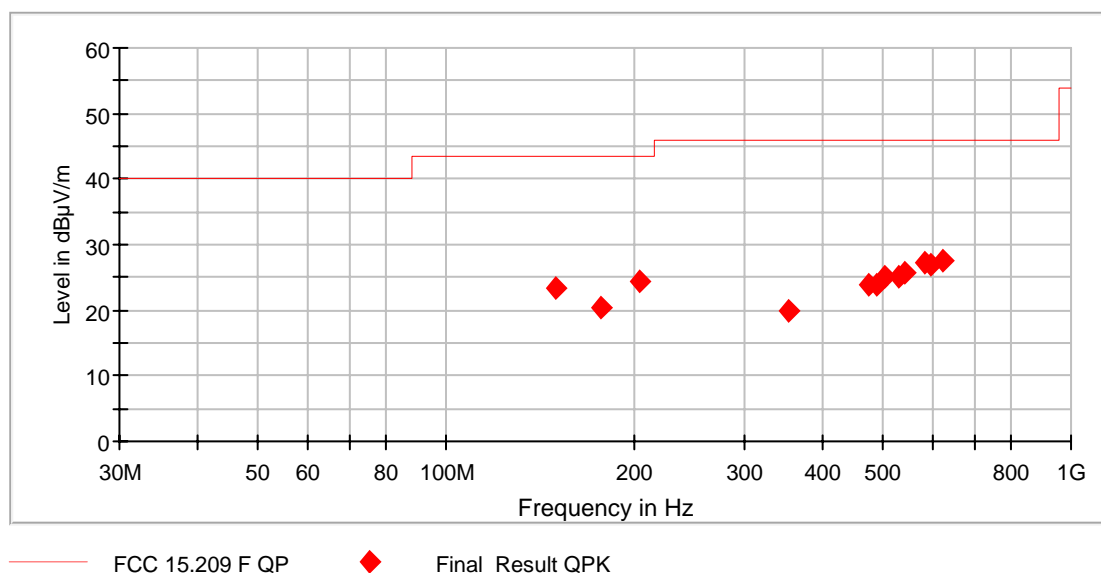

Data record name: 161000ffu

Result measured with the quasi-peak detector:

Spurious emissions outside restricted bands									
Frequency MHz	Result dB μ V/m	Limit dB μ V/m	Margin dB	Readings dB μ V	Antenna factor dB/m	Cable loss dB	Height cm	Azimuth deg	Pol.
149.163	23.1	43.5	20.4	10.1	11.7	1.3	199.0	218.0	Hor.
176.279	20.5	43.5	23.0	9.2	9.8	1.5	156.0	342.0	Hor.
203.403	23.9	43.5	19.6	13.3	9.1	1.5	139.0	0.0	Hor.
351.904	19.9	46.0	26.1	3.6	14.3	2.0	141.0	148.0	Vert.
473.808	23.9	46.0	22.1	4.7	16.8	2.4	116.0	0.0	Vert.
487.695	24	46.0	22.0	4.3	17.2	2.5	373.0	36.0	Vert.
501.583	25.2	46.0	20.8	5.3	17.4	2.5	150.0	294.0	Hor.
529.359	25.2	46.0	20.8	4.7	17.9	2.6	350.0	94.0	Vert.
541.703	25.9	46.0	20.1	4.5	18.7	2.7	380.0	48.0	Vert.
583.367	27.2	46.0	18.8	5.4	19.0	2.8	363.0	19.0	Vert.
597.255	27.0	46.0	19.0	5.0	19.2	2.8	197.0	108.0	Vert.
623.487	27.5	46.0	18.5	5.0	19.7	2.8	350.0	329.0	Hor.
Measurement uncertainty				+2.2 dB / -3.6 dB					

Test: Passed

Test equipment used (see chapter 6):

14 – 21

5.3 99 % bandwidth

5.3.1 Method of measurement

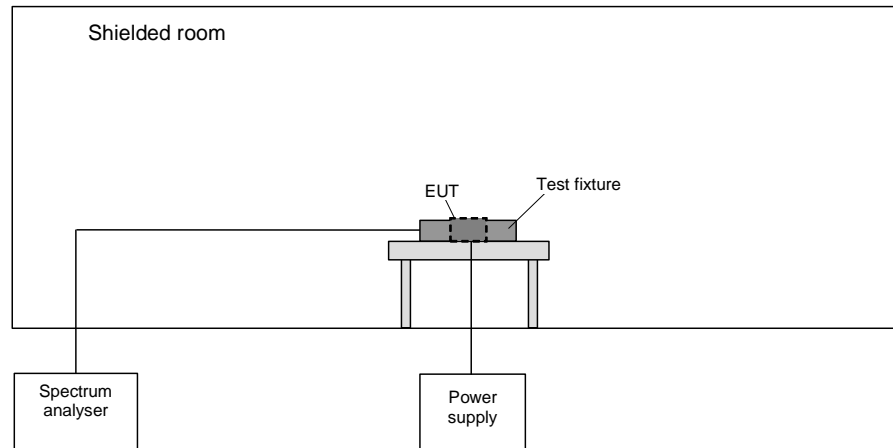

The following procedure will be used for the occupied bandwidth measurement according to [1]:

The span of the analyzer shall be set to capture all products of the modulation process, including the emission skirts. The resolution bandwidth shall be set to as close to 1% of the selected span as is possible without being below 1%. The video bandwidth shall be set to 3 times the resolution bandwidth. Video averaging is not permitted. Where practical, a sampling detector shall be used since a peak or, peak hold, may produce a wider bandwidth than actual.

The trace data points are recovered and are directly summed in linear terms. The recovered amplitude data points, beginning at the lowest frequency, are placed in a running sum until 0.5% of the total is reached and that frequency recorded. The process is repeated for the highest frequency data points. This frequency is recorded.

The span between the two recorded frequencies is the occupied bandwidth.

5.3.2 Test results

Ambient temperature:	22 °C	Relative humidity:	36 %
----------------------	-------	--------------------	------

Test record: The test was carried out in TAGs reading and writing mode of the EUT (refer also clause 2 of this test report). All results are shown in the following.

Supply voltage: During this test the EUT was powered via the EasyScan Module, which was powered with 12 V_{AC} by the PASC30U-120, which was itself supplied with 120 V_{AC} / 60 Hz.

160874_121.wmf: 99 % bandwidth at 13.56 MHz:

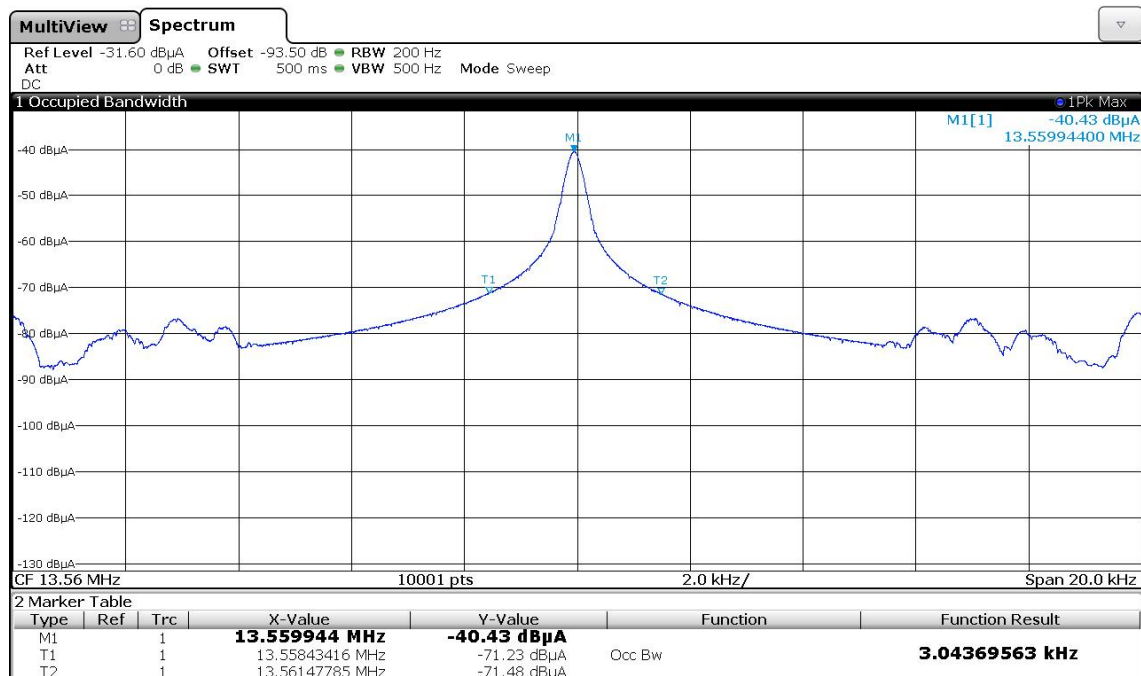

Frequency	F _L	F _U	BW (F _U - F _L)
13.56 MHz	13.558434 MHz	13.561478 MHz	3.044 kHz
Measurement uncertainty			< 1*10 ⁻⁷

Test equipment used (see chapter 6)

43, 52

6 Test equipment

No.	Test equipment	Type	Manufacturer	Serial No.	PM. No.	Cal. Date	Cal. due
1	Shielded chamber M4	-	Siemens	B83117-S1-X158-	480088	Weekly verification (system cal.)	
2	EMI Receiver	ESIB 26	Rohde & Schwarz	1088.7490	481182	02/15/2016	02/2018
3	LISN	NSLK8128	Schwarzbeck	8128161	480138	02/16/2016	02/2018
4	Transient Filter Limiter	CFL 9206A	Teseq GmbH	38268	481982	Weekly verification (system cal.)	
6	EMI Software	EMC 32	Rohde & Schwarz	100061	481022	-	-
7	Outdoor test site	-	Phoenix Test-Lab	-	480293	Weekly verification (system cal.)	
14	Open area test site	-	Phoenix Test-Lab	-	480085	Weekly verification (system cal.)	
15	Measuring receiver	ESIB7	Rohde & Schwarz	100304	480521	02/18/2016	02/2018
16	Controller	HD100	Deisel	100/670	480139	-	-
17	Turntable	DS420HE	Deisel	420/620/80	480087	-	-
18	Antenna support	AS615P	Deisel	615/310	480086	-	-
19	Antenna	CBL6111 D	Chase	25761	480894	09/18/2014	09/2017
20	EMI-Software	EMC 32	Rohde & Schwarz	-	481022	-	-
21	6 dB attenuator	R412706000	Radiall	9833	410082	Annual verification	
30	Fully anechoic chamber M20	-	Albatross Projects	B83107-E2439-T232	480303	Weekly verification (system cal.)	
31	Measuring receiver	ESI 40	Rohde & Schwarz	100064	480355	02/16/2016	02/2017
32	Controller	MCU	Maturo	MCU/043/971107	480832	-	-
33	Turntable	DS420HE	Deisel	420/620/80	480315	-	-
34	Antenna support	AS615P	Deisel	615/310	480187	-	-
35	Antenna	CBL6112 B	Chase	2688	480328	04/14/2014	04/2017
43	Spectrum analyser	FSW43	Rohde & Schwarz	100586	481720	02/24/2016	02/2018
44	RF-cable No. 36	Sucoflex 106B	Suhner	0522/6B	480571	Weekly verification (system cal.)	
51	Loop antenna	HFH2-Z2	Rohde & Schwarz	832609/014	480059	02/29/2016	02/2018
52	Loop Antenna $\varnothing = 110$ mm	-	Phoenix Test-Lab	-	410084	-	-
53	Outdoor test site	-	Phoenix Testlab	-	480293	-	-

