

# Test Report

Report Number:

**F161006E2, 3<sup>rd</sup> version**

Equipment under Test (EUT):

**QLX45 liquid dosing module**

Applicant:

**Mettler-Toledo GmbH**

Manufacturer:

**Mettler-Toledo GmbH**



Deutsche  
Akkreditierungsstelle  
D-PL-17186-01-01  
D-PL-17186-01-02  
D-PL-17186-01-03



## References

- [1] **ANSI C63.10: 2013** American National Standard of Procedures for Compliance Testing of Unlicensed Wireless Devices
- [2] **FCC CFR 47 Part 15 (October 2015)** Radio Frequency Devices
- [3] **RSS-210 Issue 9 (August 2016)** Licence-Exempt Radio Apparatus: Category I Equipment
- [4] **RSS-Gen Issue 4 (November 2014)** General Requirements for Compliance of Radio Apparatus

## Test result

The requirements of the tests performed as shown in the overview (chapter 4 of this test report) were fulfilled by the equipment under test.

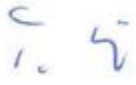
The complete test results are presented in the following.

|                      |               |  |            |
|----------------------|---------------|--|------------|
| Test engineer:       | Thomas KÜHN   |    | 12/22/2016 |
|                      | Name          | Signature  | Date       |
| Authorized reviewer: | Bernd STEINER |  | 12/22/2016 |
|                      | Name          | Signature  | Date       |

This test report is only valid in its original form.

Any reproduction of its contents in extracts without written permission of the accredited test laboratory PHOENIX TESTLAB GmbH is prohibited.

The test results herein refer only to the tested sample. PHOENIX TESTLAB GmbH is not responsible for any generalisations or conclusions drawn from these test results concerning further samples. Any modification of the tested samples is prohibited and leads to the invalidity of this test report. Each page necessarily contains the PHOENIX TESTLAB Logo and the TEST REPORT NUMBER.

This test report is valid in hardcopy form as well as in electronic form.

| <b>Contents:</b>  | <b>Page</b> |
|---|-------------|
| 1 Identification .....  | 4           |
| 1.1 Applicant .....   | 4           |
| 1.2 Manufacturer .....  | 4           |
| 1.3 Test Laboratory .....   | 4           |
| 1.4 EUT (Equipment Under Test) .....                                    | 5           |
| 1.5 Technical data of equipment .....                                   | 5           |
| 1.6 Dates .....   | 6           |
| 2 Operational states and test setup .....                               | 6           |
| 3 Additional information .....  | 7           |
| 4 Overview .....  | 7           |
| 5 Results .....   | 8           |
| 5.1 Conducted emissions on power supply lines (150 kHz to 30 MHz) ..... | 8           |
| 5.1.1 Method of measurement .....                                       | 8           |
| 5.1.2 Test results (conducted emissions on power supply lines) .....    | 9           |
| 5.2 Radiated emissions .....  | 10          |
| 5.2.1 Method of measurement (radiated emissions) .....                  | 10          |
| 5.2.2 Results preliminary measurement 9 kHz to 1 GHz .....              | 17          |
| 5.2.3 Result final measurement from 9 kHz to 30 MHz .....               | 20          |
| 5.2.4 Result final measurement from 30 MHz to 1 GHz .....               | 21          |
| 5.3 99 % bandwidth .....  | 23          |
| 5.3.1 Method of measurement .....                                       | 23          |
| 5.3.2 Test results .....  | 24          |
| 6 Test equipment .....  | 25          |
| 7 Report history .....  | 26          |
| 8 List of annexes .....   | 26          |

## 1 Identification

### 1.1 Applicant

|  |                                       |
|--|---------------------------------------|
| Name:  | Mettler-Toledo GmbH                   |
| Address:   | Im Langacher 44<br>CH-8606 Greifensee |
| Country:   | Switzerland                           |
| Name for contact purposes:                                     | Mr. David KRESS                       |
| Phone:   | +41 44 944 23 84                      |
| eMail Address:   | David.Kress@mt.com                    |
| Applicant represented during the test by the following person: | -                                     |

### 1.2 Manufacturer

|   |                                       |
|---|---------------------------------------|
| Name:   | Mettler-Toledo GmbH                   |
| Address:  | Im Langacher 44<br>CH-8606 Greifensee |
| Country:  | Switzerland                           |
| Name for contact purposes:  | Mr. David KRESS                       |
| Phone:  | +41 44 944 23 84                      |
| eMail Address:  | David.Kress@mt.com                    |
| Manufacturer represented during the test by the following person: | -                                     |

### 1.3 Test Laboratory

The tests were carried out at:

**PHOENIX TESTLAB GmbH**  
**Königswinkel 10**  
**32825 Blomberg**  
**Germany**

accredited by Deutsche Akkreditierungsstelle GmbH (DAkKS) in compliance with DIN EN ISO/IEC 17025 under Reg. No. D-PL-17186-01-02, FCC Test Firm Accreditation with the registration number 469623, designation number DE0004 and Industry Canada Test site registration SITE# IC3469A-1.

#### 1.4 EUT (Equipment Under Test)

|                               |                                     |
|-------------------------------|-------------------------------------|
| Type object: *                | Liquid dosing unit with RFID reader |
| Model name / HVIN: *          | QLX45 liquid dosing unit            |
| Serial No.:                   | None                                |
| FCC ID: *                     | THVQLX45MODULE                      |
| IC: *                         | 22032-QLX45MODULE                   |
| PCB identifier:               | 30006781 A                          |
| Hardware version: *           | N.a.                                |
| Software version / FVIN: *    | 30007722B, 30006193D, 11671200G     |
| Lowest internal frequency: *  | -                                   |
| Highest internal frequency: * | 10 MHz                              |

#### 1.5 Technical data of equipment

|                          |   |                     |                    |                    |                    |                     |
|--------------------------|---|---------------------|--------------------|--------------------|--------------------|---------------------|
| Channel 1                | RX:   | 125 kHz             | TX:                | 125 kHz            |                    |                     |
| Rated RF output power: * | <1 $\mu$ W  |                     |                    |                    |                    |                     |
| Antenna type: *          | Wired coil antenna with 0.008 m <sup>2</sup>  |                     |                    |                    |                    |                     |
| Number of channels: *    | 1   |                     |                    |                    |                    |                     |
| Antenna connector: *     | None  |                     |                    |                    |                    |                     |
| Modulation: *            | ASK   |                     |                    |                    |                    |                     |
| Data rate: *             | 5.2 kbit/s  |                     |                    |                    |                    |                     |
| Supply voltage: *        | U <sub>Nom</sub> =  | 230 V <sub>AC</sub> | U <sub>Min</sub> = | 90 V <sub>AC</sub> | U <sub>Max</sub> = | 264 V <sub>AC</sub> |
| Power supply: *          | External by PASC30U-120 (dedicated AC/DC adaptor)                                     |                     |                    |                    |                    |                     |
| Temperature range: *     | 0 °C to 40 °C   |                     |                    |                    |                    |                     |
| Ancillary used for test: | QL2 Pump unit (host, serial no. B625634979),<br>PASC30U-120 (dedicated AC/DC adaptor) |                     |                    |                    |                    |                     |

\*: declared by the applicant.

| Ports / Connectors |  |  |                    |
|--------------------|--|--|--------------------|
| Identification     | Connector  |  | Length during test |
|                    | EUT  | Ancillary  |                    |
| CAN1               | Locking Connector<br>Binder Series 712<br>5 pole | Locking Connector<br>Binder Series 712<br>5 pole | 40 cm              |
| -                  | -  | -  | -                  |
| -                  | -  | -  | -                  |

## 1.6 Dates

|                                 |            |
|---------------------------------|------------|
| Date of receipt of test sample: | 07/13/2016 |
| Start of test:                  | 07/14/2016 |
| End of test:                    | 08/11/2016 |

## 2 Operational states and test setup

The EUT is a tagging system, which is part of a liquid weighting system. As declared by the applicant, it will be connected to a pump module QL2, which is regarded as host. The pump module QL2 will always be used with a dedicated AC/DC adaptor type PASC30U-120

During all measurements a liquid dosing head with integrated TAG was mounted at the EUT.

All measurements were carried out with an unmodified sample operating in a test mode. The test mode was entered with the help of a test-software running on a laptop PC, which is connected to the pump module QL2 via the RS 232 interface. With this test mode the TAG data were cyclic read and the TAG was written. The RS232 connection between the pump module QL2 and the laptop PC was set up with the help of two fibre optics to RS232 converter.

Physical boundaries of the Equipment Under Test

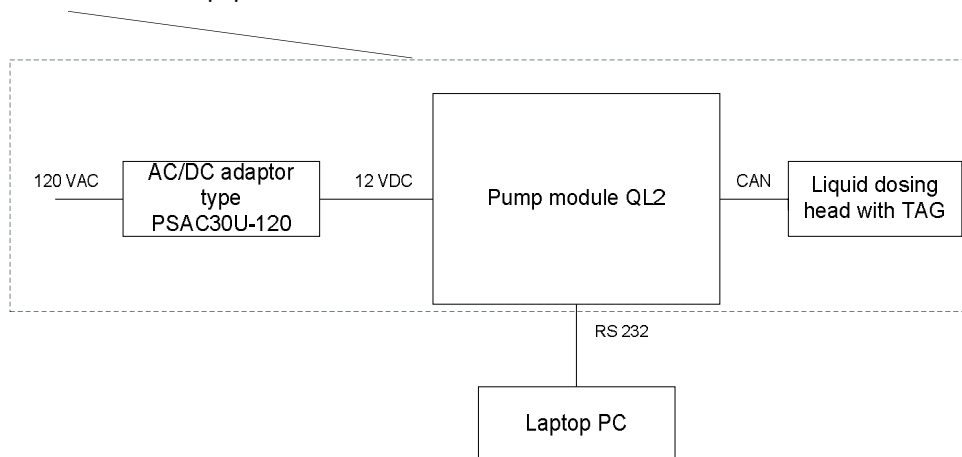

### 3 Additional information

The EUT was not labeled as required by FCC / IC.

### 4 Overview

| Application                        | Frequency range [MHz] | FCC 47 CFR Part 15 section [2] | RSS-Gen, Issue 4 [4] and RSS-210, Issue 9 [3] | Status   | Refer page |
|------------------------------------|-----------------------|--------------------------------|---|----------|------------|
| Conducted emissions on supply line | 0.15 – 30             | 15.207 (a)                     | 8.8 [4]                                       | Passed   | 8 et seq.  |
| Radiated emissions                 | 0.009 – 1.000         | 15.205 (a)<br>15.209 (a)       | 8.9 [4]<br>4.4 [3]                            | Passed   | 10 et seq. |
| 99 % bandwidth                     | 0.125                 | -                              | 6.6 [4]                                       | -        | 23 et seq. |
| Antenna requirement                | -                     | 15.203 [2]                     | -   | Passed * | -          |

\*: Integrated antenna only, requirement fulfilled.

## 5 Results

### 5.1 Conducted emissions on power supply lines (150 kHz to 30 MHz)

#### 5.1.1 Method of measurement

This test will be carried out in a shielded chamber. Tabletop devices will set up on a non-conducting support with a size of 1 m by 1.5 m and a height of 80 cm above the ground plane. Floor-standing devices will be placed directly on the ground plane. The setup of the Equipment under test will be in accordance to [1].

The frequency range 150 kHz to 30 MHz will be measured with an EMI Receiver set to MAX Hold mode with peak and average detector and a resolution bandwidth of 9 kHz. A scan will be carried out on the phase (or plus pole in case of DC powered devices) of the AC mains network. If levels detected 10 dB below the appropriate limit, this emission will be measured with the average and quasi-peak detector on all lines.

| Frequency range   | Resolution bandwidth |
|-------------------|----------------------|
| 150 kHz to 30 MHz | 9 kHz                |

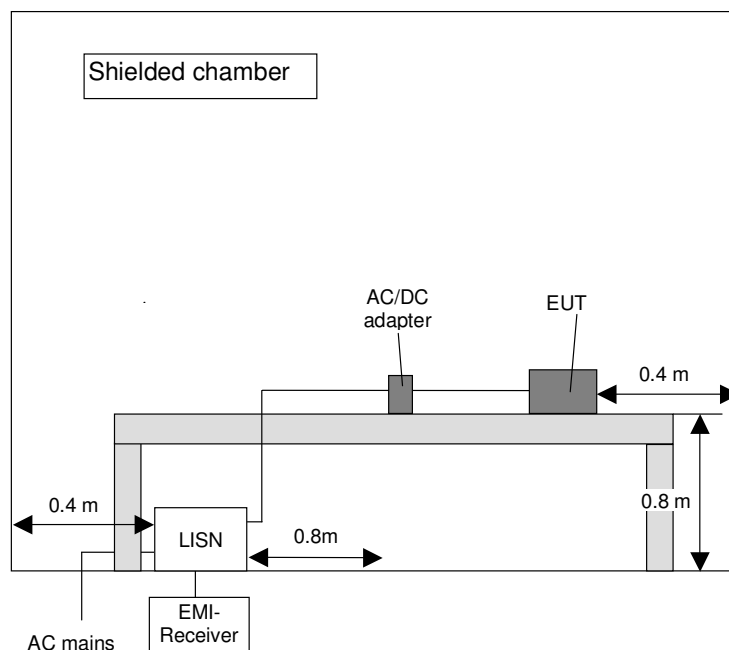



### 5.1.2 Test results (conducted emissions on power supply lines)

|                     |       |                   |      |
|---------------------|-------|-------------------|------|
| Ambient temperature | 22 °C | Relative humidity | 58 % |
|---------------------|-------|-------------------|------|

Position of EUT: The EUT was set-up on a non-conducting table of a height of 0.8 m.

Cable guide: The cables of the EUT were fixed on the non-conducting table. For further information of the cable guide refer to the pictures in annex A of this test report.

Test record: The test was carried out in TAG reading and writing mode of the EUT (refer also clause 2 of this test report). All results are shown in the following.

Supply voltage: During this test the host was powered with 12 V<sub>AC</sub> by the PASC30U-120, which was itself supplied with 120 V<sub>AC</sub> / 60 Hz.

The curves in the diagram only represent for each frequency point the maximum measured value of all preliminary measurements which were made for each power supply line. The top measured curve represents the peak measurement and the bottom measured curve the average measurement. The quasi-peak measured points are marked by **◆** and the average measured points by **+**.

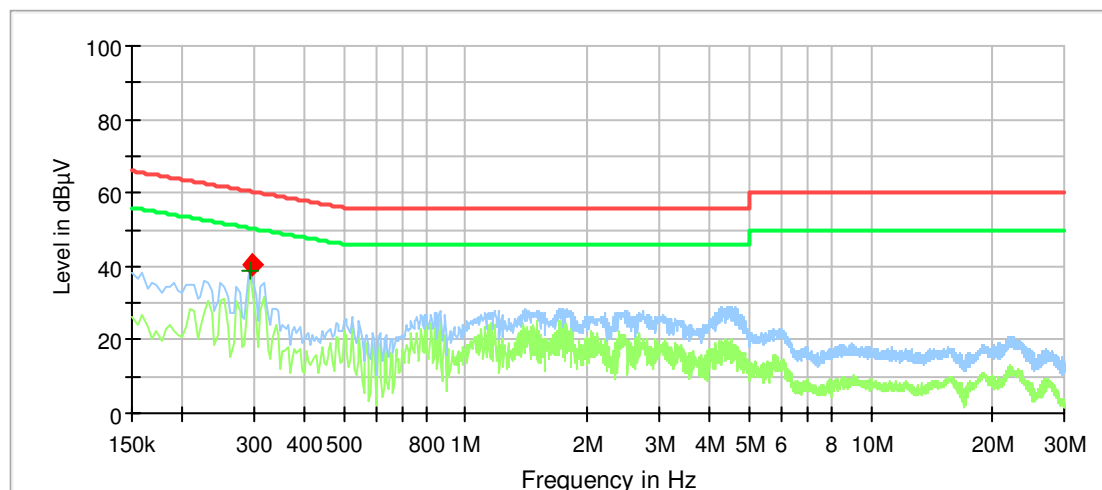

— Preview Result 2-AVG     — Preview Result 1-PK+     — FCC 15.207 V QP  
— FCC 15.207 V AV     ◆ Final\_Result QPK     + Final\_Result AVG

Data record name: 161006AC

Remark: The limits of FCC 15.207 are identical to [3]

| Frequency (MHz)         | QuasiPeak (dBµV) | Average (dBµV) | Limit (dBµV) | Margin (dB) | Meas. Time (ms)   | Bandwidth (kHz) | Line | PE  | Transducer (dB) |
|-------------------------|------------------|----------------|--------------|-------------|-------------------|-----------------|------|-----|-----------------|
| 0.294900                | ---              | 38.7           | 50.4         | 11.7        | 5000.0            | 9.000           | L1   | FLO | 9.9             |
| 0.295800                | 40.7             | ---            | 60.4         | 19.7        | 5000.0            | 9.000           | L1   | GND | 9.9             |
| Measurement uncertainty |                  |                |              |             | +6.7 dB / -6.0 dB |                 |      |     |                 |

Test: Passed

Test equipment used (see chapter 6):

|          |
|----------|
| 1 - 4, 6 |
|----------|

## 5.2 Radiated emissions

### 5.2.1 Method of measurement (radiated emissions)

The radiated emission measurement is subdivided into six stages.

- A preliminary measurement carried out in a fully anechoic chamber with a fixed antenna height in the frequency range 9 kHz to 1 GHz.
- A final measurement carried out on an outdoor test site without reflecting ground plane and a fixed antenna height in the frequency range 9 kHz to 30 MHz.
- A preliminary measurement carried out in a fully anechoic chamber with a fixed antenna height in the frequency range 30 MHz to 1 GHz.
- A final measurement carried out on an open area test site with reflecting ground plane and various antenna heights in the frequency range 30 MHz to 1 GHz.
- A preliminary measurement carried out in a fully anechoic chamber with a fixed antenna height in the frequency range 1 GHz to 5 GHz.
- A final measurement carried out in a fully anechoic chamber with a fixed antenna height in the frequency range 1 GHz to 5 GHz.

#### **Preliminary measurement (9 kHz to 30 MHz):**

In the first stage a preliminary measurement will be performed in a shielded room with a measuring distance of 3 meters. Table-top devices will set up on a non-conducting support with a size of 1 m by 1.5 m and a height of 80 cm. Floor-standing devices will be placed directly on the turntable/ground plane. The set up of the Equipment under test will be in accordance to [1].

The frequency range 9 kHz to 30 MHz will be monitored with a spectrum analyser while the system and its cables will be manipulated to find out the configuration with the maximum emission levels if applicable. The EMI Receiver will be set to MAX Hold mode. The EUT and the measuring antenna will be rotated around their vertical axis to found the maximum emissions.

The resolution bandwidth of the spectrum analyser will be set to the following values:

| Frequency range   | Resolution bandwidth |
|-------------------|----------------------|
| 9 kHz to 150 kHz  | 200 Hz               |
| 150 kHz to 30 MHz | 10 kHz               |

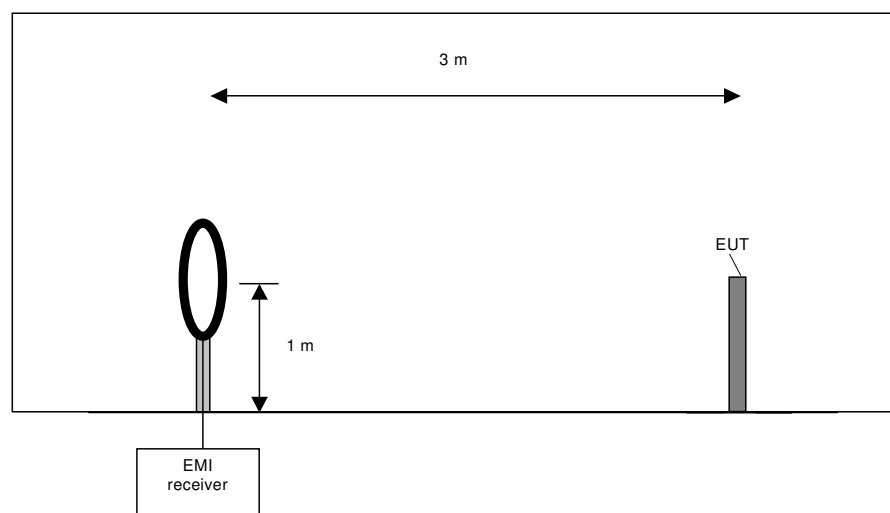

Preliminary measurement procedure:

Prescans were performed in the frequency range 9 kHz to 150 kHz and 150 kHz to 30 MHz.

The following procedure will be used:

- 1) Monitor the frequency range at horizontal polarisation and a EUT azimuth of 0 °.
- 2) Manipulate the system cables within the range to produce the maximum level of emission.
- 3) Rotate the EUT by 360 ° to maximize the detected signals.
- 4) Make a hardcopy of the spectrum.
- 5) Measure the frequencies of highest detected emission with a lower span and resolution bandwidth to increase the accuracy and note the frequency value.
- 6) Repeat steps 1) to 5) with the other orthogonal axes of the EUT (because of EUT is a module and might be used in a handheld equipment application).
- 7) Rotate the measuring antenna and repeat steps 1) to 5).

**Final measurement (9 kHz to 30 MHz):**

In the second stage a final measurement will be performed on an open area test site with no conducting ground plane in a measuring distances of 3 m, 10 m and 30 m. In the case where larger measuring distances are required the results will be extrapolated based on the values measured on the closer distances according to Section 15.31 (f) (2) [2]. The final measurement will be performed with a EMI Receiver set to Quasi Peak detector except for the frequency bands 9 kHz to 90 kHz and 110 kHz to 490 kHz where an average detector will be used according Section 15.209 (d) [2].

On the frequencies, which were detected during the preliminary measurements, the final measurement will be performed while rotating the EUT and the measuring antenna in the range of 0 ° to 360 ° around their vertical axis until the maximum value is found.

The resolution bandwidth of the EMI Receiver will be set to the following values:

| Frequency range   | Resolution bandwidth |
|-------------------|----------------------|
| 9 kHz to 150 kHz  | 200 Hz               |
| 150 kHz to 30 MHz | 9 kHz                |

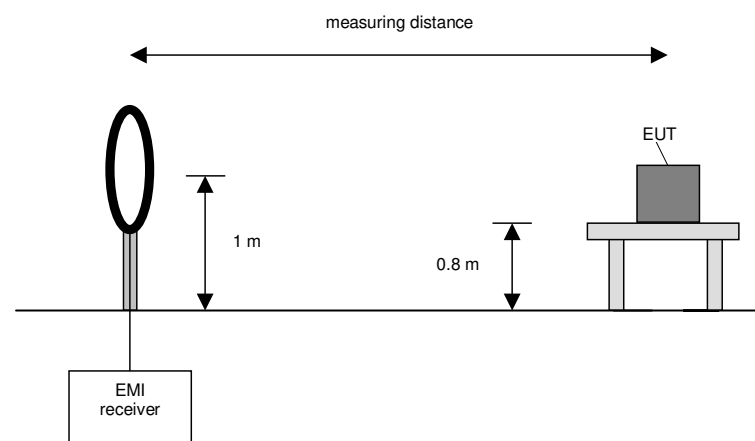

Final measurement procedure:

The following procedure will be used:

- 1) Monitor the frequency range with the measuring antenna at vertical orientation parallel to the EUT at an azimuth of 0 °.
- 2) Rotate the EUT by 360 ° to maximize the detected signals and note the azimuth and orientation.
- 3) Rotate the measuring antenna to find the maximum and note the value.
- 4) Rotate the measuring antenna and repeat steps 1) to 3) until the maximum value is found.
- 5) Repeat steps 1) to 4) with the other orthogonal axes of the EUT (if the EUT is a module and might be used in a handheld equipment application).

**Preliminary measurement (30 MHz to 1 GHz)**

In the first stage a preliminary measurement will be performed in a fully anechoic chamber with a measuring distance of 3 meter. Tabletop devices will set up on a non-conducting support with a size of 1 m by 1.5 m and a height of 80 cm. Floor-standing devices will be placed directly on the turntable/ground plane. The set up of the Equipment under test will be in accordance to [1].

The frequency range 30 MHz to 1 GHz will be measured with an EMI Receiver set to MAX Hold mode and a resolution bandwidth of 120 kHz. The measurement will be performed in horizontal and vertical polarisation of the measuring antenna and while rotating the EUT in its vertical axis in the range of 0 ° to 360 °.

The resolution bandwidth of the EMI Receiver will be set to the following values:

| Frequency range | Resolution bandwidth |
|-----------------|----------------------|
| 30 MHz to 1 GHz | 120 kHz              |

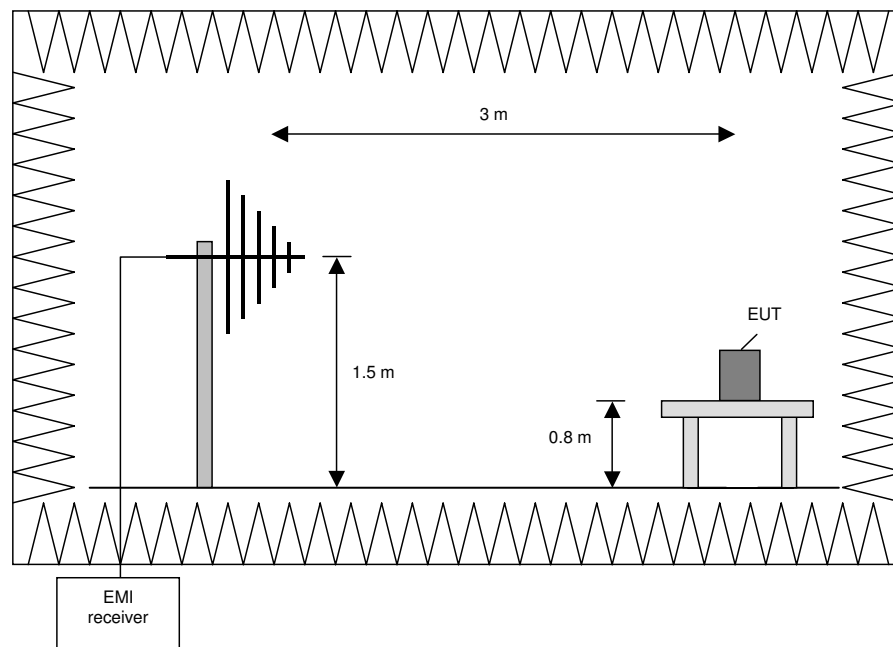

Procedure preliminary measurement:

Prescans were performed in the frequency range 30 MHz to 1 GHz.

The following procedure will be used:

1. Monitor the frequency range at horizontal polarisation and a EUT azimuth of 0 °.
2. Manipulate the system cables within the range to produce the maximum level of emission.
3. Rotate the EUT by 360 ° to maximize the detected signals.
4. Make a hardcopy of the spectrum.
5. Measure the frequency of the detected emissions with a lower span and resolution bandwidth to increase the accuracy and note the frequency value.
6. Repeat 1) to 4) with the other orthogonal axes of the EUT if handheld equipment.
7. Repeat 1) to 5) with the vertical polarisation of the measuring antenna.

**Final measurement (30 MHz to 1 GHz)**

A final measurement on an open area test site will be performed on selected frequencies found in the preliminary measurement. During this test the EUT will be rotated in the range of 0 ° to 360 °, the measuring antenna will be set to horizontal and vertical polarisation and raised and lowered in the range from 1 m to 4 m to find the maximum level of emissions.

The resolution bandwidth of the EMI Receiver will be set to the following values:

| Frequency range | Resolution bandwidth |
|-----------------|----------------------|
| 30 MHz to 1 GHz | 120 kHz              |

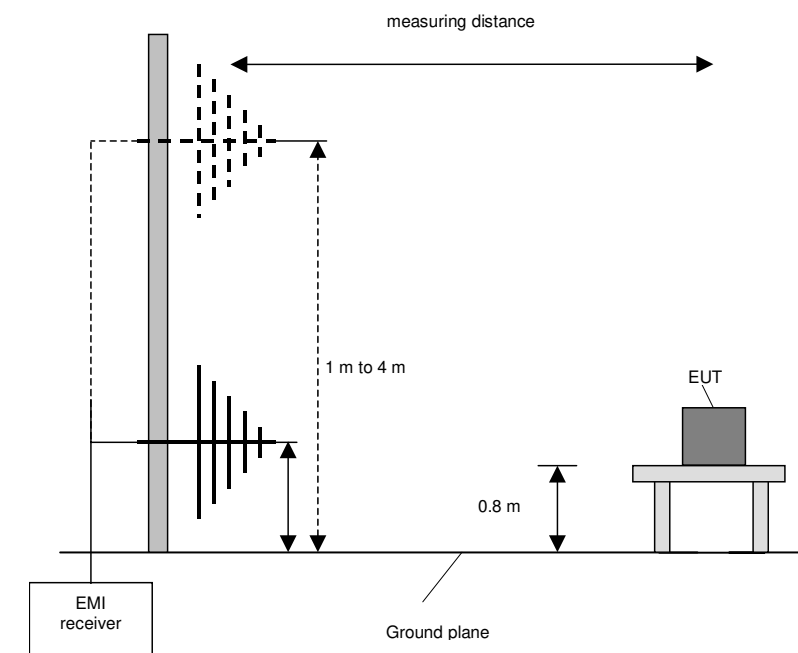

Procedure final measurement:

The following procedure will be used:

- 1) Measure on the selected frequencies at an antenna height of 1 m and a EUT azimuth of 23 °.
- 2) Move the antenna from 1 m to 4 m and note the maximum value at each frequency.
- 3) Rotate the EUT by 45 ° and repeat 2) until an azimuth of 337 ° is reached.
- 4) Repeat 1) to 3) for the other orthogonal antenna polarization.
- 5) Move the antenna and the turntable to the position where the maximum value is detected.
- 6) Measure while moving the antenna slowly +/- 1 m.
- 7) Set the antenna to the position where the maximum value is found.
- 8) Measure while moving the turntable +/- 45 °.
- 9) Set the turntable to the azimuth where the maximum value is found.
- 10) Measure with Final detector (QP and AV) and note the value.
- 11) Repeat 5) to 10) for each frequency.
- 12) Repeat 1) to 11) for each orthogonal axes of the EUT if handheld equipment.

**Preliminary and final measurement (1 GHz to 110 GHz)**

This measurement will be performed in a fully anechoic chamber. Table top devices will set up on a non-conducting turn device on the height of 1.5 m. The set-up of the Equipment under test will be in accordance to [1].

**Preliminary measurement (1 GHz to 40 GHz)**

The frequency range will be divided into different sub ranges depending of the frequency range of the used horn antenna. The spectrum analyser set to MAX Hold mode and a resolution bandwidth of 100 kHz. The measurement will be performed in horizontal and vertical polarisation of the measuring antenna and while rotating the EUT in its vertical axis in the range of 0 ° to 360 °. This measurement is repeated after raising the EUT in 30 ° steps according 6.6.5.4 in [1].

The resolution bandwidth of the EMI Receiver will be set to the following values:

| Frequency range    | Resolution bandwidth |
|--------------------|----------------------|
| 1 GHz to 4 GHz     | 1 MHz                |
| 4 GHz to 12 GHz    | 1 MHz                |
| 12 GHz to 18 GHz   | 1 MHz                |
| 18 GHz to 26.5 GHz | 1 MHz                |
| 26.5 GHz to 40 GHz | 1 MHz                |
| 40 GHz to 60 GHz   | 1 MHz                |
| 50 GHz to 75 GHz   | 1 MHz                |
| 75 GHz to 110 GHz  | 1 MHz                |

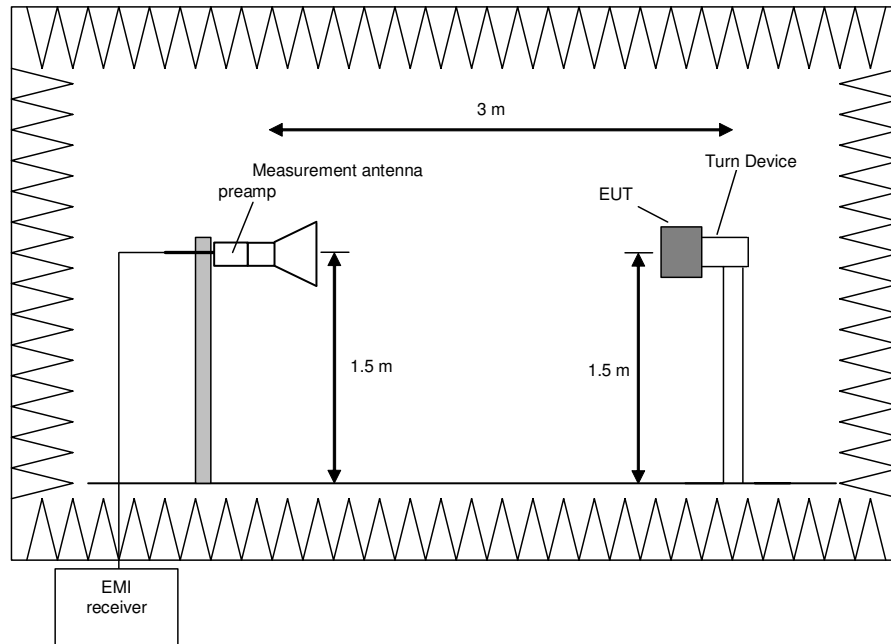

#### Procedure preliminary measurement:

Prescans were performed in the frequency range 1 to 40 GHz.

The following procedure will be used:

1. Monitor the frequency range at horizontal polarisation and a EUT azimuth of 0 °.
2. Rotate the EUT by 360° to maximize the detected signals.
3. Repeat 1) to 2) with the vertical polarisation of the measuring antenna.
4. Make a hardcopy of the spectrum.
5. Repeat 1) to 4) with the EUT raised by an angle of 30° (60°, 90°, 120° and 150°) according to 6.6.5.4 in [1].
6. Measure the frequency of the detected emissions with a lower span and resolution bandwidth to increase the accuracy and note the frequency value.
7. The measurement antenna polarisation, with the according EUT position (Turntable and Turn device) which produces the highest emission for each frequency will be used for the final measurement. The six closest values to the applicable limit will be used for the final measurement.

#### Final measurement (1 GHz to 110 GHz)

The frequency range will be divided into different sub ranges depending of the frequency range of the used antenna. The EMI Receiver set to peak and average mode and a resolution bandwidth of 1 MHz. The measurement will be performed by rotating the turntable through 0 to 360° in the worst-case EUT orientation which was obtained during the preliminary measurements.

The resolution bandwidth of the EMI Receiver will be set to the following values:

| Frequency range    | Resolution bandwidth |
|--------------------|----------------------|
| 1 GHz to 4 GHz     | 1 MHz                |
| 4 GHz to 12 GHz    | 1 MHz                |
| 12 GHz to 18 GHz   | 1 MHz                |
| 18 GHz to 26.5 GHz | 1 MHz                |
| 26.5 GHz to 40 GHz | 1 MHz                |
| 40 GHz to 60 GHz   | 1 MHz                |
| 50 GHz to 75 GHz   | 1 MHz                |
| 75 GHz to 110 GHz  | 1 MHz                |

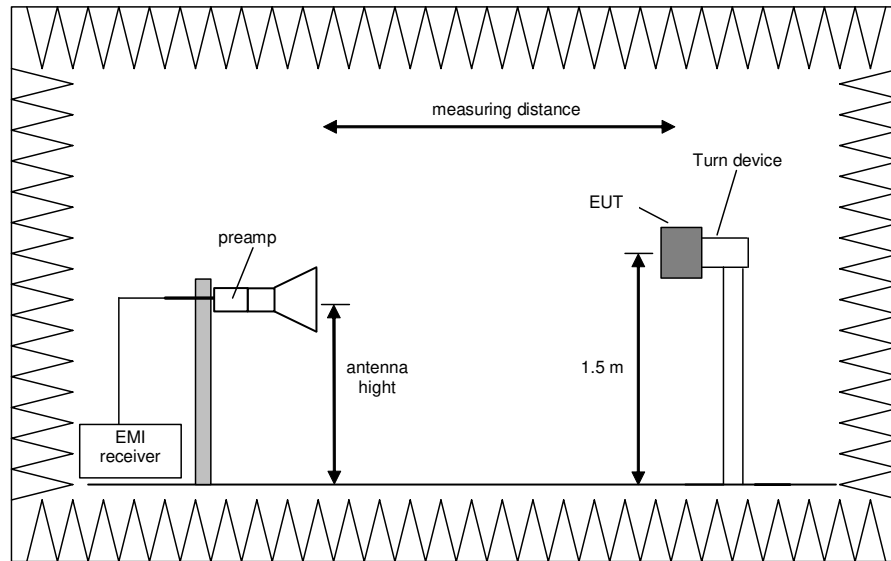

Procedure of measurement:

The measurements were performed in the frequency range 1 GHz to 110 GHz.  
The following procedure will be used:

- 1) Set the turntable and the turn device to obtain the worst-case emission for the first frequency identified in the preliminary measurements.
- 2) Set the measurement antenna polarisation to the orientation with the highest emission for the first frequency identified in the preliminary measurements.
- 3) Set the spectrum analyser to EMI mode with peak and average detector activated.
- 4) Rotate the turntable from 0° to 360° to find the EUT angle that produces the highest emissions.
- 5) Note the highest displayed peak and average values
- 6) Repeat the steps 1) to 5) for each frequency detected during the preliminary measurements.



## 5.2.2 Results preliminary measurement 9 kHz to 1 GHz

|                     |       |                   |      |
|---------------------|-------|-------------------|------|
| Ambient temperature | 22 °C | Relative humidity | 50 % |
|---------------------|-------|-------------------|------|

- Position of EUT: The EUT was set-up on a non-conducting table.
- Cable guide: The cable of the EUT was fixed on the non-conducting table. For further information of the cable guide refer to the pictures in annex A of this test report.
- Test record: The test was carried out in TAG reading and writing mode of the EUT (refer also clause 2 of this test report). All results are shown in the following.
- Power supply: During this test the host was powered with 12 V<sub>AC</sub> by the PASC30U-120, which was itself supplied with 120 V<sub>AC</sub> / 60 Hz.
- Frequency range: According to [2] from 9 kHz to 1 GHz.

### 161006\_101.wmf: Spurious emissions from 9 kHz to 150 kHz

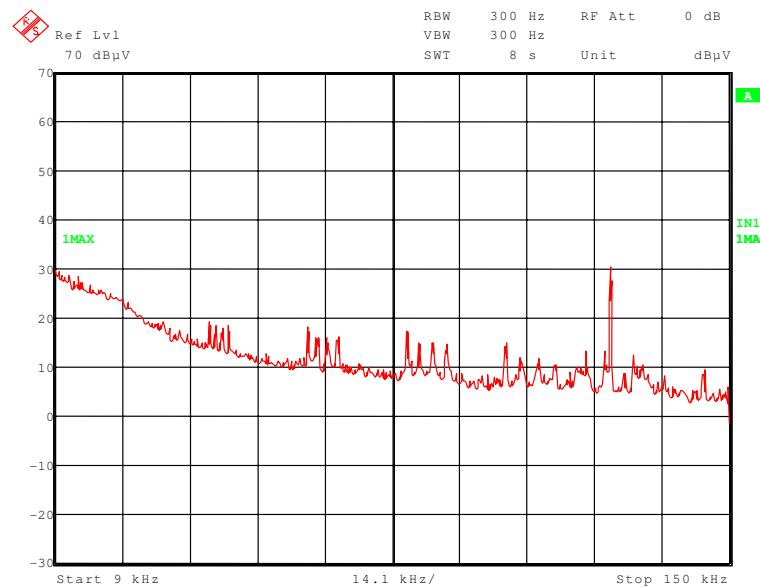

161006\_102.wmf: Spurious emissions from 150 kHz to 1 MHz

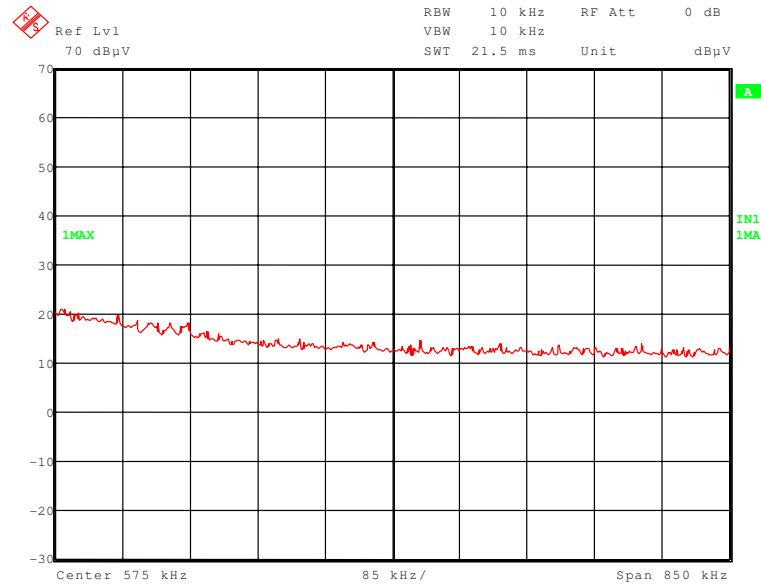

161006\_103.wmf: Spurious emissions from 1 MHz to 30 MHz

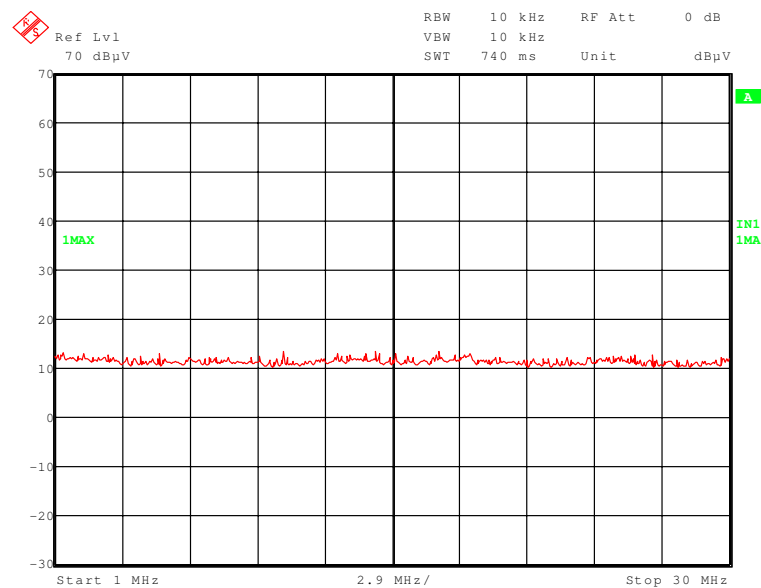

The following emissions were found according to [2] and [3].

62.000 kHz, 82.645 kHz, 103.195 kHz, 118.117 kHz, 125.000 kHz and 131.228 kHz.

These frequencies have to be measured on the outdoor test site. The result is presented in the following.

161006\_104.wmf: Spurious emissions from 30 MHz to 230 MHz

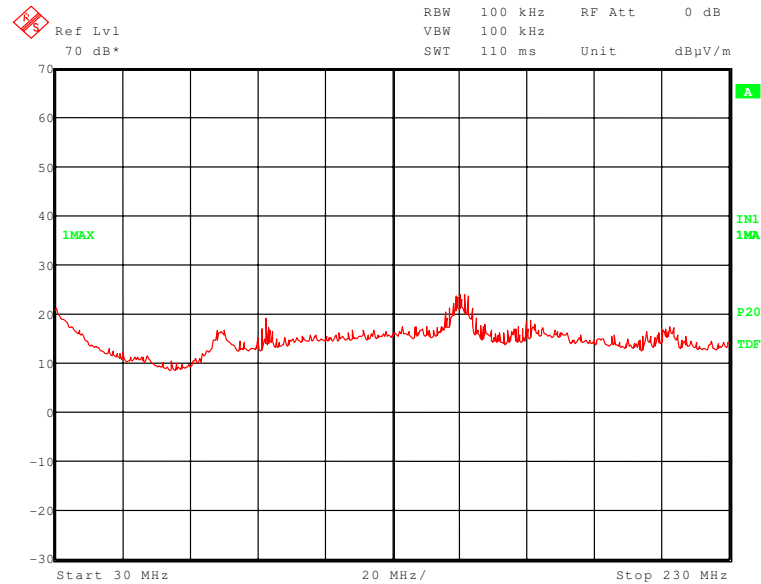

161006\_105.wmf: Spurious emissions from 230 MHz to 1 GHz

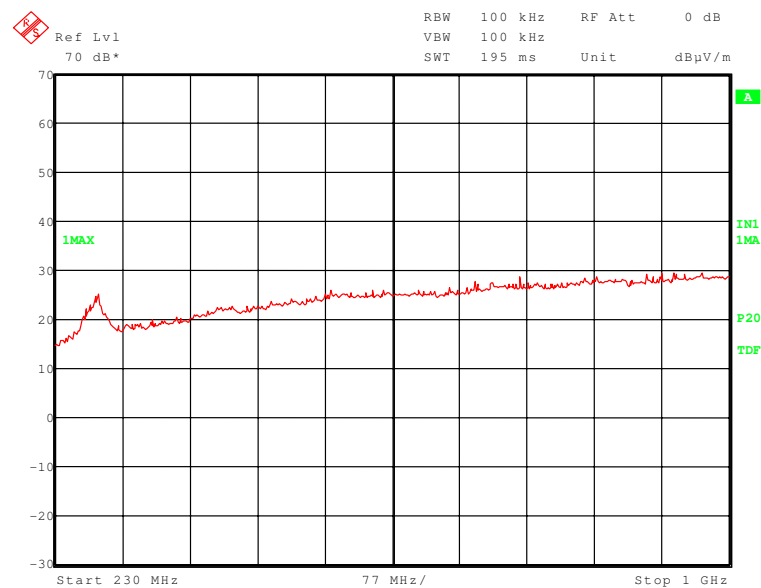

The following frequencies were found emission test outside restricted bands during the preliminary radiated:

- 79.509 MHz, 92.350 MHz and 151.436 MHz.

The following frequency was found inside the restricted bands during the preliminary radiated.

- 277.090 MHz.

These frequencies have to be measured on the open area test site. The results were presented in the following.

Test equipment used (see chapter 6)

30 – 35, 44, 51

### 5.2.3 Result final measurement from 9 kHz to 30 MHz

|                     |       |                   |      |
|---------------------|-------|-------------------|------|
| Ambient temperature | 11 °C | Relative humidity | 70 % |
|---------------------|-------|-------------------|------|

Position of EUT: The EUT was set-up on a non-conducting table of a height of 0.8 m. The distance between EUT and antenna was 3 m and 10 m.

Cable guide: The cable of the EUT was fixed on the non-conducting support. For further information of the cable guide refer to the pictures in annex A of this test report.

Test record: The test was carried out in TAG reading and writing mode of the EUT (refer also clause 2 of this test report). All results are shown in the following.

Power supply: During this test the host was powered with 12 V<sub>AC</sub> by the PASC30U-120, which was itself supplied with 120 V<sub>AC</sub> / 60 Hz.

Test results: The test results were calculated with the following formula:

$$\text{Result [dB}\mu\text{V/m]} = \text{reading [dB}\mu\text{V]} + \text{antenna factor [dB/m]}$$

| Results with measuring distance of 3 m     |   |                                  |           |          |                     |                                   |
|--|---|----------------------------------|-----------|----------|---------------------|-----------------------------------|
| Frequency kHz                              | Result dB $\mu$ V/m   | Limit <sup>2)</sup> dB $\mu$ V/m | Margin dB | Detector | Readings dB $\mu$ V | Antenna factor <sup>1)</sup> dB/m |
| 62.000                                     | 24.6  | 111.8                            | 87.2      | AV       | 4.6                 | 20.0                              |
| 82.645                                     | 22.7  | 109.3                            | 86.6      | AV       | 2.7                 | 20.0                              |
| 103.195                                    | 29.6  | 107.3                            | 77.7      | QP       | 9.6                 | 20.0                              |
| 118.117                                    | 18.6  | 106.2                            | 87.6      | AV       | -1.4                | 20.0                              |
| 125.000                                    | 48.0  | 105.7                            | 57.7      | AV       | 28                  | 20.0                              |
| 131.228                                    | 19.1  | 105.2                            | 86.1      | AV       | -0.9                | 20.0                              |
| Results with measuring distance of 10 m    |   |                                  |           |          |                     |                                   |
| Frequency kHz                              | Result dB $\mu$ V/m   | Limit <sup>2)</sup> dB $\mu$ V/m | Margin dB | Detector | Readings dB $\mu$ V | Antenna factor <sup>1)</sup> dB/m |
| -  | All signals were below the noise floor of the measuring system at 10 m distance |                                  |           |          |                     |                                   |
| Measurement uncertainty: +2.2 dB / -3.6 dB |   |                                  |           |          |                     |                                   |

<sup>1)</sup>: Cable loss included

<sup>2)</sup>: Limits according to [2] and [3] extrapolated with a factor of 40 dB/decade according to [2]

Test: Passed

Test equipment used for the test:

31, 51, 53

## 5.2.4 Result final measurement from 30 MHz to 1 GHz

|                     |       |                   |      |
|---------------------|-------|-------------------|------|
| Ambient temperature | 21 °C | Relative humidity | 60 % |
|---------------------|-------|-------------------|------|

- Position of EUT:** The EUT was setup on a non-conducting table of a height of 0.8 m. The distance between EUT and antenna was 3 m.
- Test record:** The test was carried out in TAG reading and writing mode of the EUT (refer also clause 2 of this test report). All results are shown in the following.
- Power supply:** During this test the host was powered with 12 V<sub>AC</sub> by the PASC30U-120, which was itself supplied with 120 V<sub>AC</sub> / 60 Hz.
- Test results:** The test results were calculated with the following formula:  

$$\text{Result [dB}\mu\text{V/m]} = \text{reading [dB}\mu\text{V]} + \text{cable loss [dB]} + \text{antenna factor [dB/m]} + 6 \text{ dB}$$

The measured points and the limit line in the following diagrams refer to the standard measurement of the emitted interference in compliance with the above-mentioned standard. The measured points marked with an ◆ are the measured results of the standard final measurement on the open area test site.

The results of the standard subsequent measurement on the open area test site are indicated in the table below. The limits as well as the measured results (levels) refer to the above mentioned standard while taking account of the specified requirements for a 3 m measuring distance.

The measurement time with the quasi-peak measuring detector is 5 seconds.

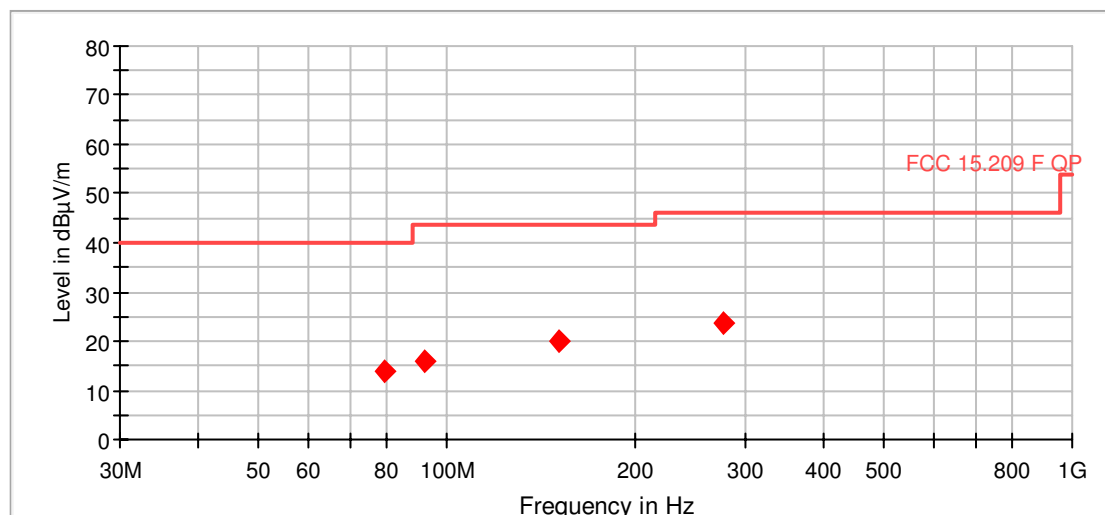

— FCC 15.209 F QP      ◆ Final\_Result QPK

Data record name: 161006ffu

**Result measured with the quasi-peak detector:**

| Spurious emissions inside restricted bands  |              |              |        |                   |                |            |        |         |            |
|---|--------------|--------------|--------|-------------------|----------------|------------|--------|---------|------------|
| Frequency                                   | Result       | Limit        | Margin | Readings          | Antenna factor | Cable loss | Height | Azimuth | Pol.       |
| MHz   | dB $\mu$ V/m | dB $\mu$ V/m | dB     | dB $\mu$ V        | dB/m           | dB         | cm     | deg     |            |
| 79.509                                      | 13.8         | 40.0         | 26.2   | 4.7               | 8.1            | 1.0        | 278.0  | 49.0    | Horizontal |
| 92.350                                      | 15.8         | 43.5         | 27.7   | 4.3               | 10.4           | 1.1        | 200.0  | 230.0   | Horizontal |
| 151.436                                     | 20.1         | 43.5         | 23.4   | 7.1               | 11.7           | 1.3        | 198.0  | 78.0    | Horizontal |
| Spurious emissions outside restricted bands |              |              |        |                   |                |            |        |         |            |
| 277.090                                     | 23.7         | 46.0         | 22.3   | 9.3               | 12.5           | 1.9        | 102.0  | 53.0    | Horizontal |
| Measurement uncertainty                     |              |              |        | +2.2 dB / -3.6 dB |                |            |        |         |            |

Test: Passed

Test equipment used (see chapter 6):

14 – 21

## 5.3 99 % bandwidth

### 5.3.1 Method of measurement

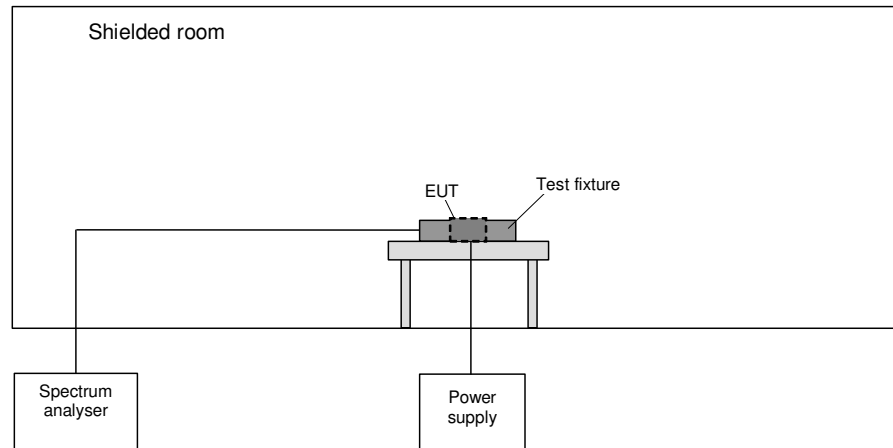

The following procedure will be used for the occupied bandwidth measurement according to [1]:

The span of the analyzer shall be set to capture all products of the modulation process, including the emission skirts. The resolution bandwidth shall be set to as close to 1% of the selected span as is possible without being below 1%. The video bandwidth shall be set to 3 times the resolution bandwidth. Video averaging is not permitted. Where practical, a sampling detector shall be used since a peak or, peak hold, may produce a wider bandwidth than actual.

The trace data points are recovered and are directly summed in linear terms. The recovered amplitude data points, beginning at the lowest frequency, are placed in a running sum until 0.5% of the total is reached and that frequency recorded. The process is repeated for the highest frequency data points. This frequency is recorded.

The span between the two recorded frequencies is the occupied bandwidth.

### 5.3.2 Test results

|                      |       |
|----------------------|-------|
| Ambient temperature: | 21 °C |
|----------------------|-------|

|                    |      |
|--------------------|------|
| Relative humidity: | 47 % |
|--------------------|------|

Test record: The test was carried out in TAG reading and writing mode of the EUT (refer also clause 2 of this test report). All results are shown in the following.

Power supply: During this test the host was powered with 12 V<sub>AC</sub> by the PASC30U-120, which was itself supplied with 120 V<sub>AC</sub> / 60 Hz.

161006\_106.wmf: 99 % bandwidth at 20 °C / 120 V<sub>AC</sub>:

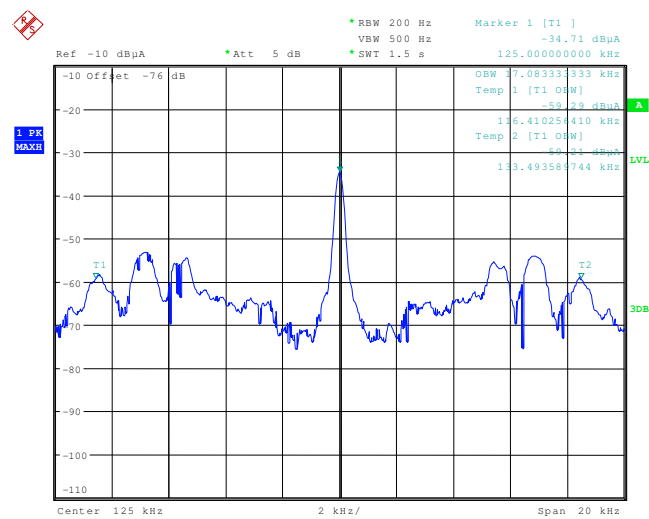

| $F_L$                   | $F_U$       | BW ( $F_U - F_L$ )  |
|-------------------------|-------------|---------------------|
| 116.410 kHz             | 133.494 kHz | 17.083 kHz          |
| Measurement uncertainty |             | $< 1 \cdot 10^{-7}$ |

Test equipment used (see chapter 6)

|        |
|--------|
| 43, 52 |
|--------|



## 6 Test equipment

| No. | Test equipment                      | Type          | Manufacturer       | Serial No.        | PM. No. | Cal. Date                         | Cal. due |
|-----|-------------------------------------|---------------|--------------------|-------------------|---------|-----------------------------------|----------|
| 1   | Shielded chamber M4                 | -             | Siemens            | B83117-S1-X158-   | 480088  | Weekly verification (system cal.) |          |
| 2   | EMI Receiver                        | ESIB 26       | Rohde & Schwarz    | 1088.7490         | 481182  | 02/15/2016                        | 02/2018  |
| 3   | LISN                                | NSLK8128      | Schwarzbeck        | 8128161           | 480138  | 02/16/2016                        | 02/2018  |
| 4   | Transient Filter Limiter            | CFL 9206A     | Teseq GmbH         | 38268             | 481982  | Weekly verification (system cal.) |          |
| 6   | EMI Software                        | EMC 32        | Rohde & Schwarz    | 100061            | 481022  | -                                 | -        |
| 7   | Outdoor test site                   | -             | Phoenix Test-Lab   | -                 | 480293  | Weekly verification (system cal.) |          |
| 14  | Open area test site                 | -             | Phoenix Test-Lab   | -                 | 480085  | Weekly verification (system cal.) |          |
| 15  | Measuring receiver                  | ESIB7         | Rohde & Schwarz    | 100304            | 480521  | 02/18/2016                        | 02/2018  |
| 16  | Controller                          | HD100         | Deisel             | 100/670           | 480139  | -                                 | -        |
| 17  | Turntable                           | DS420HE       | Deisel             | 420/620/80        | 480087  | -                                 | -        |
| 18  | Antenna support                     | AS615P        | Deisel             | 615/310           | 480086  | -                                 | -        |
| 19  | Antenna                             | CBL6111 D     | Chase              | 25761             | 480894  | 09/18/2014                        | 09/2017  |
| 20  | EMI-Software                        | EMC 32        | Rohde & Schwarz    | -                 | 481022  | -                                 | -        |
| 21  | 6 dB attenuator                     | R412706000    | Radiall            | 9833              | 410082  | Annual verification               |          |
| 30  | Fully anechoic chamber M20          | -             | Albatross Projects | B83107-E2439-T232 | 480303  | Weekly verification (system cal.) |          |
| 31  | Measuring receiver                  | ESI 40        | Rohde & Schwarz    | 100064            | 480355  | 02/16/2016                        | 02/2017  |
| 32  | Controller                          | MCU           | Maturo             | MCU/043/971107    | 480832  | -                                 | -        |
| 33  | Turntable                           | DS420HE       | Deisel             | 420/620/80        | 480315  | -                                 | -        |
| 34  | Antenna support                     | AS615P        | Deisel             | 615/310           | 480187  | -                                 | -        |
| 35  | Antenna                             | CBL6112 B     | Chase              | 2688              | 480328  | 04/14/2014                        | 04/2017  |
| 43  | Spectrum analyser                   | FSU46         | Rohde & Schwarz    | 200125            | 480956  | 02/17/2016                        | 02/2017  |
| 44  | RF-cable No. 36                     | Sucoflex 106B | Suhner             | 0522/6B           | 480571  | Weekly verification (system cal.) |          |
| 51  | Loop antenna                        | HFH2-Z2       | Rohde & Schwarz    | 832609/014        | 480059  | 02/29/2016                        | 02/2018  |
| 52  | Loop Antenna $\varnothing = 110$ mm | -             | Phoenix Testlab    | -                 | 410084  | -                                 | -        |
| 53  | Outdoor test site                   | -             | Phoenix Testlab    | -                 | 480293  | -                                 | -        |

