



WARRANTY

ALL PRODUCT IS SUBJECT TO TESTING UPON RETURN FOR WARRANTY CLAIMS. AN RGA MUST ACCOMPANY ANY RETURNED PRODUCT. IF IT IS DETERMINED THAT THE PRODUCT IS WORKING PROPERLY, IT WILL BE RETURNED AT THE CUSTOMERS EXPENSE. SENSORS WILL NOT BE DEEMED WARRANTYABLE IF DAMAGED FROM MISUSE, OR INCORRECT APPLICATION.

Orange-Electronic products are warranted to be free from defects in material and workmanship for 6 months from delivery to purchaser. Orange-Electronic will at its discretion replace any merchandise during the warranty period.

ALL OTHER WARRANTIES IMPLIED OR EXPRESSED ARE DISCLAIMED. LIABILITY AND LOSSES RESULTING FROM SUCH CLAIMS ARE EXCLUDED, REGARDLESS OF CIRCUMSTANCES FORESEEABLE, OR UNFORSEEN.

The warranty shall be void if any of the following occur:

- 1. improper installation of products; or**
- 2. improper usage; or**
- 3. induction of defect by other products; or**
- 4. mishandling of product; or**
- 5. incorrect application; or**
- 6. damage due to collision or tire failure; or**
- 7. racing or competition; or**
- 8. exceeding the specific limits of the product.**

FCC and IC Notice

This device complies with Part 15 of the FCC Rules and with RSS-210 of Industry Canada. Operation is subject to the following two conditions:
(1) this device may not cause harmful interference, and
(2) this device must accept any interference received, including interference that may cause undesired operation.

Warning : Any changes or modifications in construction of this device which are not expressly approved by the party responsible for compliance could void the user's authority to operate the equipment.

Orange Electronic Co., LTD
Address : No 15, Lane 81, Sec 2, Tanfu Rd., Tanzih, Taichung, Taiwan
TEL : 886-4-2538-8086
FAX : 886-4-2538-8028
<http://www.orange-electronic.com>



TPM Sensor Installation Instructions

1. Make sure and clean valve stem hole in rim of any corrosion or dirt
2. Remove washer, nut and cap from the valve stem on the sensor.
3. Push valve stem through the rim, install washer, tighten nut to $4\pm 0.5\text{Nm}$ then tighten cap.
4. Holding sensor body down against rim while tighten screw.

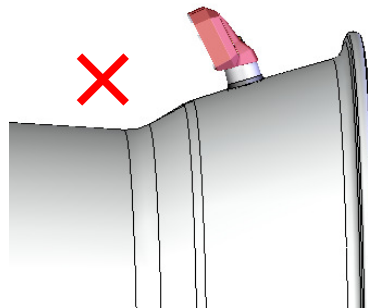
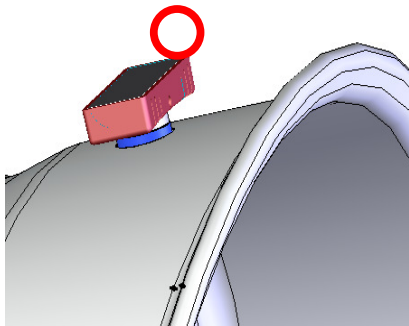
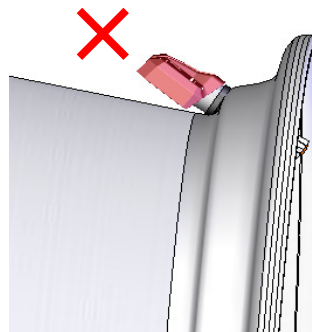
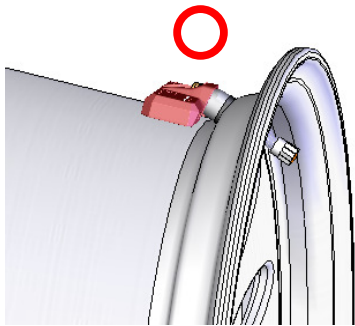
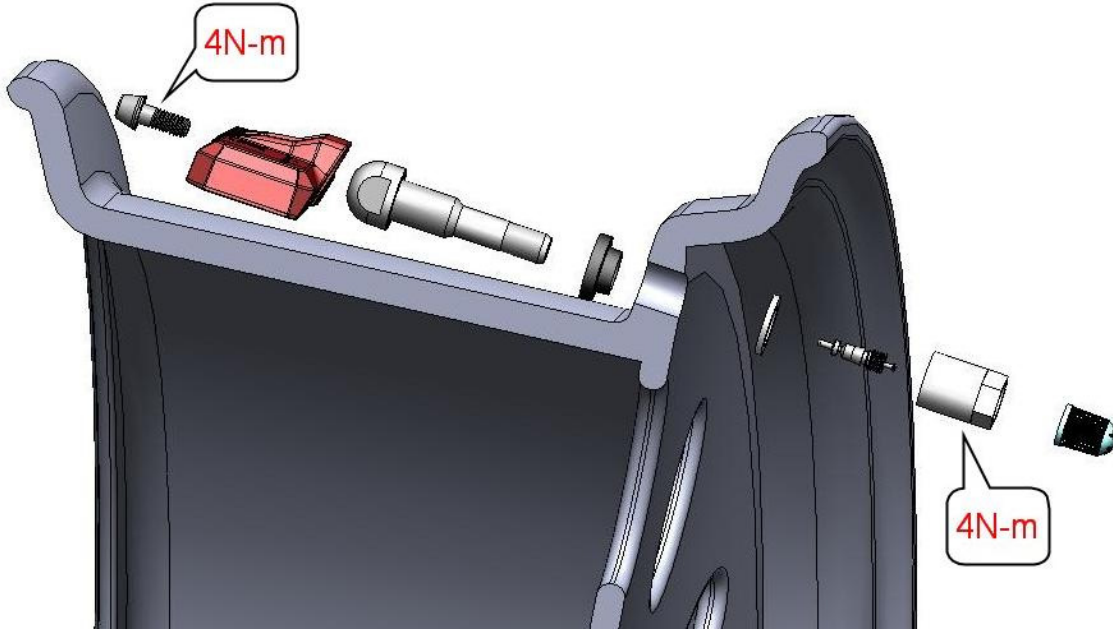

Replace grommet and screw with every tire change.

It is imperative to replace the sensor if sensor is externally damaged (especially the plastic bridge part where the valve stem is connected.)