



# WARRANTY

**ALL PRODUCT IS SUBJECT TO TESTING UPON RETURN FOR WARRANTY CLAIMS. AN RGA MUST ACCOMPANY ANY RETURNED PRODUCT. IF IT IS DETERMINED THAT THE PRODUCT IS WORKING PROPERLY, IT WILL BE RETURNED AT THE CUSTOMERS EXPENSE. SENSORS WILL NOT BE DEEMED WARRANTYABLE IF DAMAGED FROM MISUSE, OR INCORRECT APPLICATION.**

*Orange-Electronic products are warranted to be free from defects in material and workmanship for 6 months from delivery to purchaser. Orange-Electronic will at its discretion replace any merchandise during the warranty period.*

**ALL OTHER WARRANTIES IMPLIED OR EXPRESSED ARE DISCLAIMED. LIABILITY AND LOSSES RESULTING FROM SUCH CLAIMS ARE EXCLUDED, REGARDLESS OF CIRCUMSTANCES FORESEEABLE, OR UNFORSEEN.**

**The warranty shall be void if any of the following occur:**

- 1. improper installation of products; or**
- 2. improper usage; or**
- 3. induction of defect by other products; or**
- 4. mishandling of product; or**
- 5. incorrect application; or**
- 6. damage due to collision or tire failure; or**
- 7. racing or competition; or**
- 8. exceeding the specific limits of the product.**

## FCC Notice

This device complies with Part 15 of the FCC Rules and with RS-210 of Industry Canada. Operation is subject to the following two conditions:  
(1) this device may not cause harmful interference, and  
(2) this device must accept any interference received, including interference that may cause undesired operation.

**Warning :** Any changes or modifications in construction of this device which are not expressly approved by the party responsible for compliance could void the user's authority to operate the equipment.

**Orange Electronic Co., LTD**  
**Address : 2F,No.91,Lane36, Sec.2, Tansign Rd.,**  
**Tanzih Township, Taichung County 427, Taiwan.**  
**TEL : 886-4-2538-8086**  
**FAX : 886-4-2538-8028**  
**<http://www.orange-electronic.com>**



## TPM Sensor Installation Instructions

1. Make sure and clean valve stem hole in rim of any corrosion or dirt
2. Remove washer, nut and cap from the valve stem on the sensor.
3. Push valve stem through the rim, install washer, tighten nut to  $4\pm 0.5\text{Nm}$  then tighten cap.
4. Holding sensor body down against rim while tighten screw.

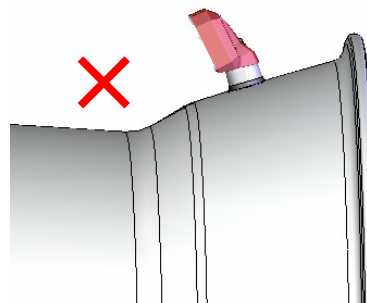
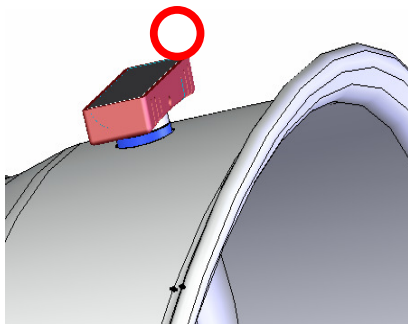
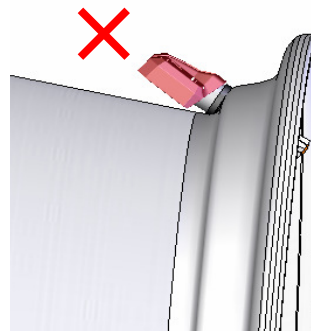
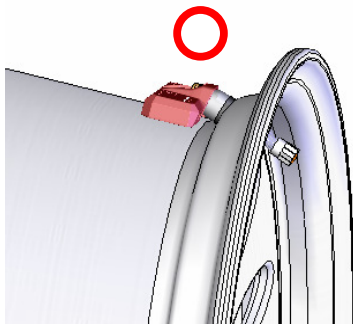
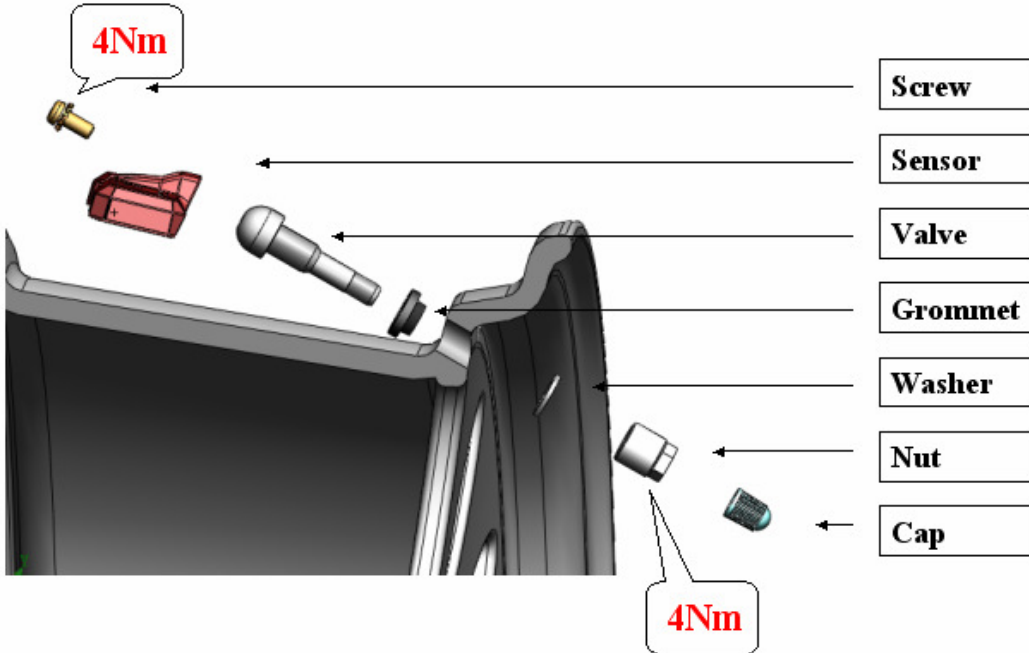

Each time a tire is serviced or dismounted, it is imperative to replace the grommet with Orange parts to ensure proper sealing.

It is imperative to replace the sensor if sensor is externally damaged (especially the plastic bridge part where the valve stem is connected.)

### FCC Notice:

1. This device and its antenna(s) must not be co-located or operating in conjunction with any other antenna or transmitter.
2. Changes or modifications to this unit not expressly approved by the party responsible for compliance could void the user authority to operate the equipment.