

SOUNDTRACK

QUICK START GUIDE

GUIDE DE PRISE

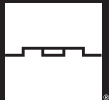

WELCOME

Welcome to your SOL REPUBLIC Soundtrack.

Soundtrack Headphones boasts a 42-hour battery life, along with rapid charge technology to minimize downtime between uses. In keeping with SOL REPUBLIC style and convenience, they also feature a built in mic and controls, and a foldable design for easy travel and storage.

SOL REPUBLIC is proud to support the soundtrack to your life.

BIENVENUE

Félicitations pour votre nouvelle acquisition de SOL REPUBLIC Soundtrack.

Le casque Soundtrack offre une autonomie de 42 heures et est muni de la technologie de charge rapide pour réduire les indisponibilités entre les utilisations. Élégant et pratique, le casque SOL REPUBLIC est aussi muni d'un microphone et de commandes intégrés et peut être replié pour un transport et un rangement faciles.

SOL REPUBLIC est fière de vous apporter la bande-son qui vous accompagnera dans votre vie.

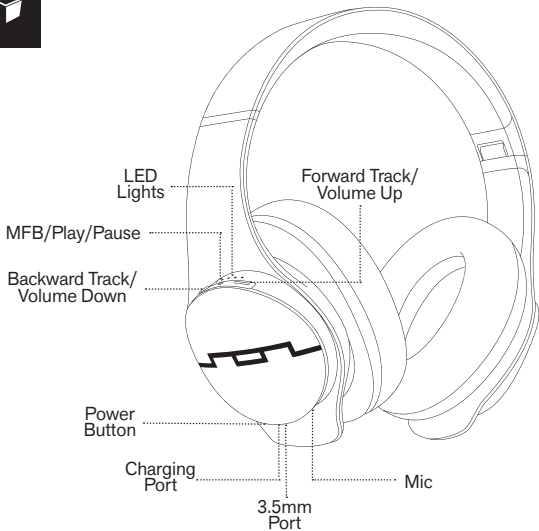

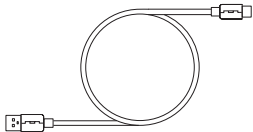

USB-C Charging cable

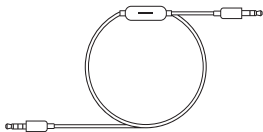

1-Button Detachable Cable



Instruction Book



Warranty Book

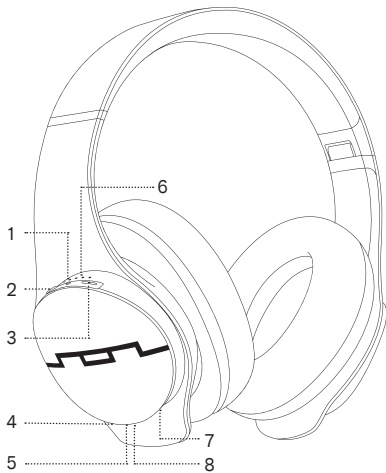

1. Play/Pause + Answer/End Call + Decline Call (2 sec) + Voice Assist (2x)

Lecture/Pause + Répondre/Terminer appel + Refuser appel (2s) + Assistance vocale (2x)

Reproducir/Pausar + Contestar/Finalizar llamada + Rechazar llamada (2 seg.) + Asistencia de voz (2x)

Riproduci/Pausa + Rispondi/Termina chiamata + Rifiuta chiamata (2 sec) + Assist vocale (2x)

Wiedergabe/Pause + Antworten/Anruf beenden + Anruf ablehnen (2 Sek) + Voice Assistent (2x)

播放/暫停 + 接聽/結束來電 + 拒-來電 (2秒) + 聲音助手 (2x)

2. Volume Down + Backward Track (2 sec)

Diminution volume + Piste précédente (2s)

Bajar volumen + Regresar pista (2 seg.)

Abbassa volume + Brano precedente (2 sec)

Lautstärke leiser + Zum vorherigen Titel (2 Sek)

減小音量 + 退回 (2秒)

3. Volume Up + Forward Track (2 sec)

Augmentation volume + Piste suivante (2s)

Subir volumen + Adelantar pista (2 seg.)

Alza volume + Brano successivo (2 sec)

Lautstärke lauter + Zum nächsten Titel (2 Sek)

增大音量 + 快進 (2秒)

4. Power Button (3 sec)

Bouton alimentation (3s)

Botón de encendido (3 seg.)

Pulsante di accensione (3 sec)

Ein-/Ausschalter (3 Sek)

電源鍵 (3秒)

5. Charging Port

Port de charge

Puerto de carga

Porta di carica

Ladeanschluss

充電口

6. LED Lights

Voyant à LED

Luces LED

Spie LED

LED-Leuchten

LED 顯示燈

7. Microphone

Microphone

Micrófono

Microfono

Mikrofon

麥克風

8. 3.5mm Port

Port 3,5 mm

Puerto de 3.5 mm

Porta 3,5 mm

3,5 mm Anschluss

3.5毫米接口



1

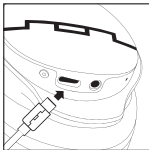

2

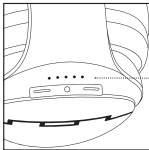

RED
ROJO
ROUGE
ROT
ROSSO
RØD
PIROS
CZERWONY
КРАСНЫЙ
ROOD

PUNAINEN
RÖD
ΚΟΚΚΙΝΟΣ
VERMELHO
KIRMIZI
「紅
赤
빨간

3

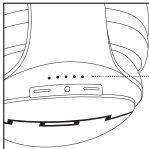

BLUE
AZUL
BLEU
BLAU
BLU
BLÅ
KĚK
NIEBIESKI
СИНИЙ
BLAUW

SININEN
MILAE
MAVI
「色
藍色
「平
은

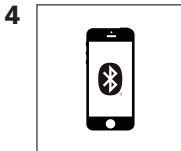
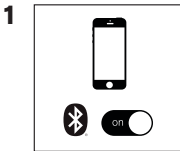

SELECT "SOUNDTRACK"

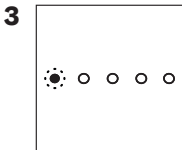
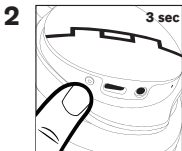

PAIRING MODE:
PULSING BLUE/RED LED

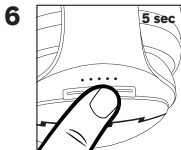

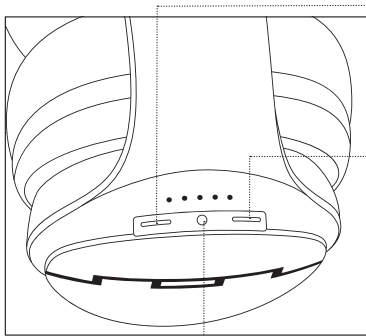

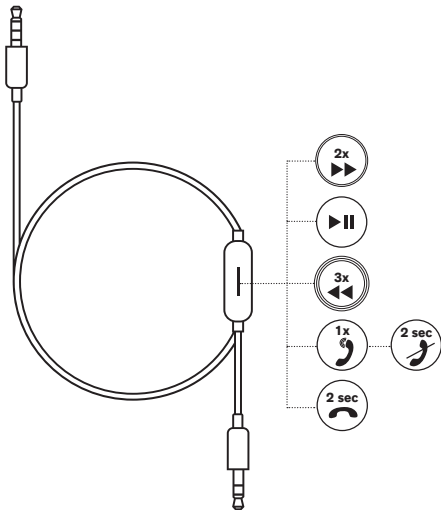

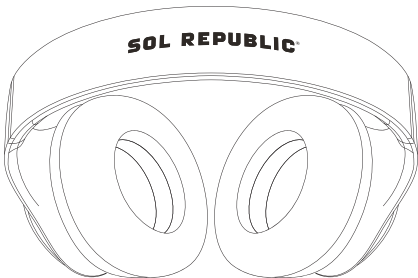

ようこそ

SOL REPUBLIC Soundtrack をお求めいただき、ありがとうございます。

Soundtrack ヘッドフォンは、ダウンタイムを最小化する高速充電機能を搭載したヘッドフォンで、通常使用で連続 42 時間。SOL REPUBLIC のスタイルと利便性を継承し、一体型マイクを搭載。旅行や持ち運びに便利な折りたたみ式です。

SOL REPUBLIC は、自信を持って皆様のサウンドトラック・ライフをサポートします。



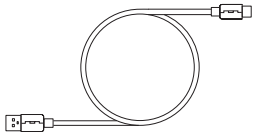

USB-C 充電ケーブル

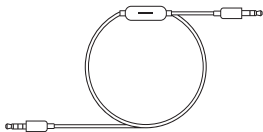

シングルボタン デジタル
タッチケーブル



取扱説明書



保証書



1

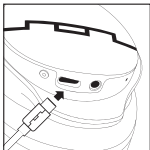

充電するには

4

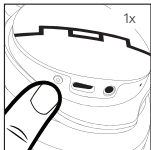

ステータス

2

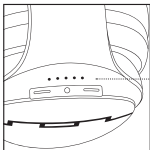

充電中



赤

3

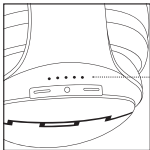

フル充電



青

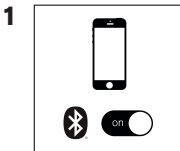

Bluetooth® オン

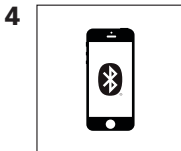

“Soundtrack” を選択

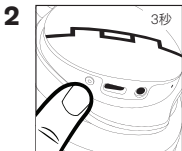

電源オン



接続中

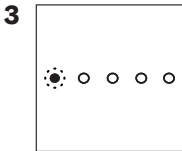

ペアリングモード：
青 / 赤 LED 点滅

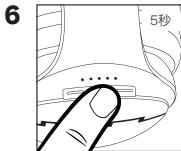

ペアリング解除

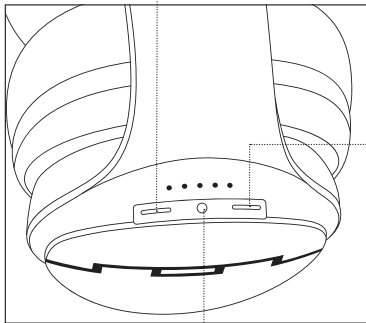

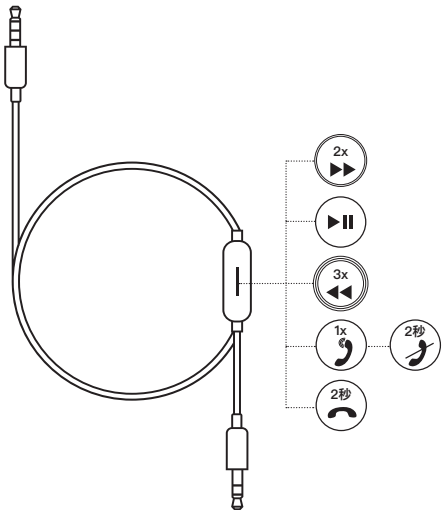

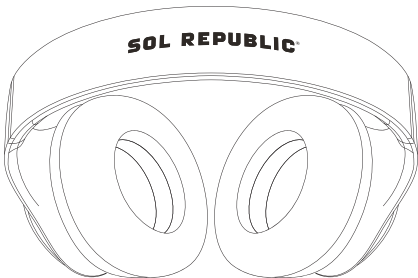

환영합니다

SOL REPUBLIC Soundtrack 에 오신 것을 환영합니다.

Soundtrack 헤드폰은 사용 중단 시간을 최소화하는 급속 충전 기술과 함께 42시간의 배터리 수명을 자랑합니다.

SOL REPUBLIC의 스타일과 편의성에 잘 어울리는 내장 마이크와 컨트롤도 장착하고 있으며, 접이식 디자인을 사용해 휴대와 보관이 편리합니다.

SOL REPUBLIC 은 고객의 사운드트랙을 지원하는 것에 자부심을 느낍니다.



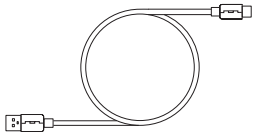

USB-C 충전 케이블

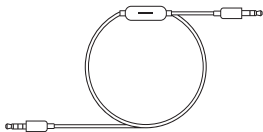

탈부착 가능한 원 버튼 케이블



지침서



보증서



1

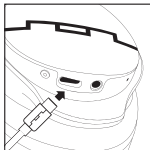

충전 방법

4

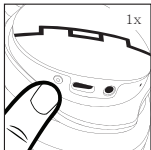

상태

2

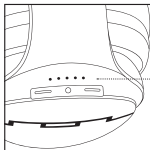

충전 중



빨간색

3

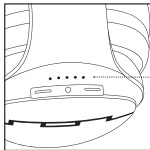

완충



파란색

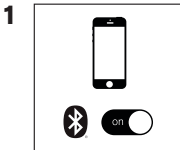

Bluetooth® 켜짐

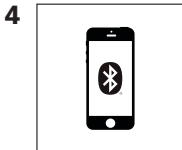

“Soundtrack” 선택

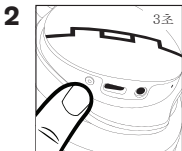

전원 켜짐



연결됨

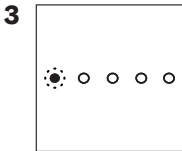

페어링 모드: 파란색
/빨간색 LED 점멸

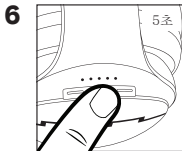

페어링 해제

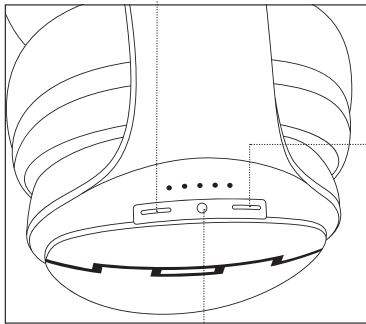

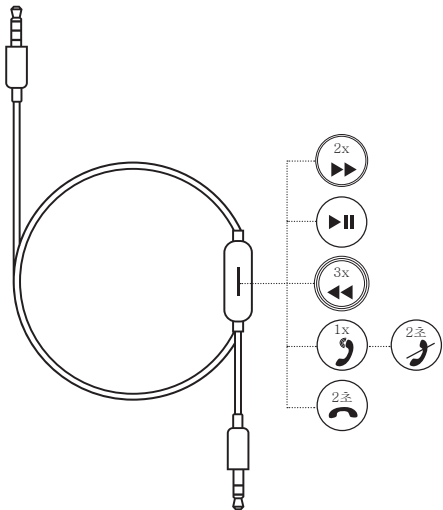

Full instruction and warranty details can be found at
<http://www.SOLREPUBLIC.com/instructionbooks>

Para obtener libro de instrucciones, detalles de garantía y excepciones, visite
<http://www.SOLREPUBLIC.com/instructionbooks>

Pour les informations complètes et les exceptions, rendezvous sur
<http://www.SOLREPUBLIC.com/instructionbooks>

Weitere Informationen und Ausnahmen erhalten Sie hier
<http://www.SOLREPUBLIC.com/instructionbooks>

Per maggiori informazioni visitare il sito
<http://www.SOLREPUBLIC.com/instructionbooks>

Komplette anvisninger og oplysninger om garanti kan findes på
<http://www.SOLREPUBLIC.com/instructionbooks>

Teljes útmutató és garancianyilatkozat:
<http://www.SOLREPUBLIC.com/instructionbooks>

Pełna instrukcja i warunki gwarancji są dostępne na stronie:
<http://www.SOLREPUBLIC.com/instructionbooks>

Úplné pokyny a detaily záruky nájdete na
<http://www.SOLREPUBLIC.com/instructionbooks>

Правила и условия гарантии полностью изложены по адресу
<http://www.SOLREPUBLIC.com/instructionbooks>

De volledige handleiding en garantiegegevens kunnen hier worden gevonden:
<http://www.SOLREPUBLIC.com/instructionbooks>

Fullstendige instruksjoner og garantidetaljer kan finnes på
<http://www.SOLREPUBLIC.com/instructionbooks>

Täydelliset ohjeet ja takuu löytyvät osoitteesta
<http://www.SOLREPUBLIC.com/instructionbooks>

Fullständiga instruktioner och garantiinformation finns på
<http://www.SOLREPUBLIC.com/instructionbooks>

Μπορείτε να βρείτε πλήρεις οδηγίες και λεπτομέρειες για την εγγύηση στη διεύθυνση
<http://www.SOLREPUBLIC.com/instructionbooks>

Instruções completas e informações da garantia podem encontrar-se em
<http://www.SOLREPUBLIC.com/instructionbooks>

Talimat ve garanti detaylarının tamamına
<http://www.SOLREPUBLIC.com/instructionbooks>
adresinden erişilebilir

如需查看完整说明和质保详情，请访问
<http://www.SOLREPUBLIC.com/instructionbooks>

如需完整說明與保固詳情，請瀏覽
<http://www.SOLREPUBLIC.com/instructionbooks>

取扱説明書の全文および保証内容の詳細は、
<http://www.SOLREPUBLIC.com/instructionbooks>
をご覧ください。

자세한 설명과 품질보증서 세부사항은
<http://www.SOLREPUBLIC.com/instructionbooks>
에서 확인할 수 있습니다.



인증받은자의 상호: (주)디엠에이
씨인터내셔널

제품명/모델명:특정소출력무선기
기(무선데이터통신시스템용무선기
기)/SOL-HP1400

제조사 및 제조국가: FKA
Distributing Co., LLC / China

인증번호:
R-C-DMV-SOL-HP1400

제품명 (Product name):
SOUNDTRACK

모델명 (Model): SOL-HP1400

해당무선설비는운용중전파혼신가
능성이있

해당무선설비는전파혼신가능성이
있으므로인명안전과관련된서비스
는할수없음

NCC Warning Message

低功率電波輻射性電機管理辦法
第十二條 經型式認證合格之低功
率射頻電機，非經許可，公司、
商號或使用者均不得擅自變更頻
率、加大功率或變更原設計之特性
及功能。

第十四條 低功率射頻電機之使用不
得影響飛航安全及干擾合法通信；
經發現有干擾現象時，應改善至無
干擾時方得繼續使用。

前項合法通信，指依電信法規定作
業之無線電通信。

低功率射頻電機 須忍受合法通信或
工業、科學及醫療用電波輻射性電
機設備之干擾。

FOR CUSTOMER SERVICE INQUIRIES, PLEASE EMAIL
SUPPORT@SOLREPUBLIC.COM

©2014-2019 SR HOMEDICS, LLC. ALL RIGHTS RESERVED.

THE **SOL REPUBLIC** WORD MARK AND LOGO ARE
REGISTERED TRADEMARKS OF **SR HOMEDICS, LLC.**

THE BLUETOOTH® WORD MARK AND LOGOS ARE REGISTERED TRADEMARKS OWNED
BY BLUETOOTH SIG, INC. AND ANY USE OF SUCH MARKS BY SOL REPUBLIC IS
UNDER LICENSE.

POUR JOINDRE LE SERVICE À LA CLIENTÈLE, VEUILLEZ ENVOYER UN
E-MAIL À **SUPPORT@SOLREPUBLIC.COM**

©2014-2019 SR HOMEDICS, LLC. TOUS DROITS

RÉSERVÉS. **SOL REPUBLIC** ET LE LOGO **SOL REPUBLIC**
SONT DES MARQUES DÉPOSÉES DE **SR HOMEDICS, LLC.**

OPERATING FREQUENCY BAND (RF):

BLUETOOTH: 2402-2480MHZ (TX-RX)

CE MAX. OF TRANSMIT POWER:

BDR/EDR: 3.54dBm

BLE: 2.09dBm

© 2019 SR Homedics, LLC. All rights reserved.

The SOL REPUBLIC word mark and logo are registered trademarks of SR Homedics, LLC.

Due to continuous product improvements, the picture on the package may differ slightly from the actual product. For Australia, the included warranty complies with regulation 90 of the Competition and Consumer Regulations 2010. The Bluetooth® word mark and logos are registered trademarks owned by Bluetooth SIG, Inc. and any use of such marks by SR Homedics, LLC is under license.

© 2019 SR Homedics, LLC. Tous droits réservés.

SOL REPUBLIC le et logo SOL REPUBLIC, sont des marques de commerce de SR Homedics, LLC. Images du produit peuvent varier du produit réel. Pour l'Australie, la garantie fournie est conforme à la réglementation 90 de la concurrence et des consommateurs Règlement 2010. La marque Bluetooth® et les logos sont des marques déposées appartenant à Bluetooth SIG, Inc. et toute utilisation de ces marques par SR Homedics, LLC est sous licence.



QS-SOLHP1400



R-C-DMV-SOL-HP1400

XU100702-19036A

(주)디엠에이씨인터내셔널

Quick Start Guide
Model: SOL-HP1400
QS-SOLHP1400

© 2019 SOL REPUBLIC

WARRANTY INFO

& COMPLIANCE

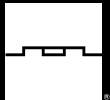

WARRANTY – US & CANADA

SOL REPUBLIC warrants this product free from defect in material and workmanship for a period of 1 year from the date of purchase. This warranty does not cover damage caused by misuse or abuse; accident; the attachment of any unauthorized accessory; alteration to the product; or any other conditions whatsoever that are beyond the control of SOL REPUBLIC.

GARANTIE

SOL REPUBLIC garantit ce produit contre tout défaut de matière et de fabrication pendant 2 ans à compter de la date d'achat. Cette garantie ne couvre pas tout dommage occasionné par un usage incorrect ou abusif, un accident, le raccordement de tout accessoire non autorisé, la modification du produit ou par toute

autre situation, de quelque nature qu'elle soit, indépendante de SOL REPUBLIC.

Distributed in Canada by/Distribue par HOMEDICS GROUP CANADA 6460 Kennedy Road, Unit C Mississauga, ON L5T 2X4 Tel: 888.225.7378. Email: cservice@homedicsgroup.ca

WARRANTY – UK & EUROPE

SOL REPUBLIC warrants this product free from defect in material and workmanship for a period of 2 years from the date of purchase. This warranty does not cover damage caused by misuse or abuse; accident; the attachment of any unauthorized accessory; alteration to the product; or any other conditions whatsoever that are beyond the control of SOL REPUBLIC. Distributed in the EU by FKA Brands Ltd., Somerhill Business Park, Five Oak Green Road, TONBRIDGE, Kent TN11 0GP. UK.

Tel: 020 7862 6099.

Email: support@SOLREPUBLIC.co.uk

WARRANTY – AUSTRALIA (ONE YEAR LIMITED WARRANTY)

We or us means HoMedics Australia Pty Ltd ACN 31 103 985 717 and our contact details are set out at the end of this warranty; You means the purchaser or the original end-user of the Goods. You may be a domestic user or a professional user; Supplier means the authorised distributor or retailer of the Goods that sold you the Goods in Australia and New Zealand; and Goods means the product or equipment which was accompanied by this warranty and purchased in Australia and New Zealand.

For Australia:

Our Goods come with guarantees that cannot be excluded under the Australian Consumer Law. You are

entitled, subject to the provisions of the Australian Consumer Law, to a replacement or refund for a major failure and for compensation for any other reasonably foreseeable loss or damage. You are also entitled, subject to the provisions of the Australian Consumer Law, to have the Goods repaired or replaced if the goods fail to be of acceptable quality and the failure does not amount to a major failure. This is not a complete statement of your legal rights as a consumer.

For New Zealand:

Our Goods come with guarantees that cannot be excluded under the Consumer Guarantees Act 1993. This guarantee applies in addition to the conditions and guarantees implied by that legislation.

The Warranty

HoMedics sells its products with the intent that they are free of defects in manufacture and workmanship under normal use and service. In the

unlikely event that your HoMedics product proves to be faulty within 1 year from the date of purchase due to workmanship or materials only, we will replace it at our own expense, subject to the terms and conditions of this guarantee. The warranty period is limited to 3 months from the date of purchase for products used commercially/professionally.

Terms and Conditions:

In addition to the rights and remedies that you have under the Australian Consumer Law, Consumer Guarantees Act of New Zealand or any other applicable law and without excluding such rights and remedies warranty against defects:

The Goods are designed to withstand the rigors of normal household use and are manufactured to the highest standards using the highest quality components. Whilst unlikely, if, during the first 12 months (3 months commercial use) from their date of

purchase from the Supplier (Warranty Period), the Goods prove defective by reason of improper workmanship or materials and none of your statutory rights or remedies apply, we will replace the Goods, subject to the terms and conditions of this warranty.

We do not have to replace the Goods under this Additional Warranty if the Goods have been damaged due to misuse or abuse, accident, the attachment of any unauthorised accessory, alteration to the product, improper installation, unauthorised repairs or modifications, improper use of electrical/power supply, loss of power, malfunction or damage of an operating part from failure to provide manufacturer's recommended maintenance, transportation damage, theft, neglect, vandalism, environmental conditions or any other conditions whatsoever that are beyond the control of HoMedics.

This Warranty does not extend to

the purchase of used, repaired or second-hand products or to products not imported or supplied by HoMedics Australia Pty Ltd, including but not limited to those sold on offshore internet auction sites.

This Warranty extends only to consumers and does not extend to Suppliers.

Even when we do not have to replace the Goods, we may decide to do so anyway. In some cases, we may decide to substitute the Goods with a similar alternative product of our choosing. All such decisions are at our absolute discretion.

All such replaced or substituted Goods continue to receive the benefit of this Additional Warranty for the time remaining on the original Warranty Period (or three months, whichever is the longest).

This Additional Warranty does not cover items damaged by normal wear and tear including but not

limited to chips, scratches, abrasions, discolouration and other minor defects, where the damage has negligible effect on the operation or performance of the Goods.

This Additional Warranty is limited to replacement or substitution only. As far as the law permits, we will not be liable for any loss or damage caused to property or persons arising from any cause whatsoever and shall have no liability for any incidental, consequential or special damages.

This warranty is only valid and enforceable in Australia and New Zealand.

Making a Claim:

In order to claim under this Warranty you must return the Goods to the Supplier (place of purchase) for replacement. If this is not possible, please contact our customer service department by email: cservice@homedics.com.au or at the address below.

All returned Goods must be accompanied by satisfactory proof of purchase which clearly indicates the name and address of the Supplier, the date and place of purchase and identifies product. It is best to provide an original, legible and unmodified receipt or sales invoice.

You must bear any expense for return of the Goods or otherwise associated with making your claim under this Additional Warranty.

Distributed in Australia by HOMEDICS AUSTRALIA PTY LTD, 14 Kingsley Close, Rowville, Victoria 3178.

Distributed in New Zealand by Phoenix Distribution NZ Ltd, 7B Orbit Drive, Albany / North Shore 0757, Auckland, New Zealand

GARANTÍA

SOL REPUBLIC garantiza que este producto está libre de defectos de material y mano de obra durante un periodo de 2 años a partir de la fecha

de compra. Esta garantía no cubre los daños causados por el mal uso o abuso, accidentes, acoplamiento de accesorios no autorizados, cualquier alteración al producto, u otras condiciones ajenas al control de SOL REPUBLIC.

HERSTELLERGARANTIE

FKA Brands Ltd. verkauft seine SOL REPUBLIC Produkte mit dem Ziel, dass diese frei von Mängeln und technischen Defekten sind. FKA Brands Ltd. gewährt auf seine SOL REPUBLIC- Produkte eine 2-jährige Herstellergarantie auf neue Produkte ab dem Kaufdatum. Diese Garantie gilt nicht für Schäden durch unsachgemäßen Gebrauch oder Missbrauch sowie bei Anbringung von unzulässigem Zubehör sowie bei selbst vorgenommenen Änderungen am Produkt. Ein Garantieanspruch ist für gebraucht gekaufte Produkte ausgeschlossen Die Garantie

gilt für Produkte, die für den bestimmungsgemäßen Gebrauch innerhalb der EU und Großbritannien hergestellt worden sind. FKA Brands Ltd. und seine angeschlossenen Gesellschaften haften nicht für Neben-, Folgeschäden. Im Garantiefall wenden Sie sich bitte unter Vorlage des Kaufbeleges an FKA Brands Ltd., Somerhill Business Park, Five Oak Green Road, Tonbridge, Kent TN11 0GP oder kontaktieren unseren Kundenservice per Email support@SOLREPUBLIC.de bzw. Telefonisch unter 0049 (0) 23 4978 49039. Unabhängig von dieser Garantie haben Sie selbstverständlich die vollen gesetzlichen Gewährleistungsrechte gegenüber dem Verkäufer. Im Gewährleistungsfall wenden Sie sich bitte mit dem entsprechenden Kaufbeleg an den Verkäufer.

GARANZIA

FKA Brands Ltd. garantisce il presente prodotto contro difetti di materiale e lavorazione per un periodo di 2 anni dalla data di acquisto. La presente garanzia non copre eventuali danni causati dall'utilizzo improprio del prodotto, da eventi accidentali, dall'uso di accessori non omologati, da alterazioni apportate al prodotto o da altre condizioni al di fuori del controllo di SOL REPUBLIC. Email: support@SOLREPUBLIC.it

保証

SOL REPUBLICは、お買い上げ日から2年間、本製品の素材および仕上がりには欠陥がないことを保証いたします。本保証は、不適切な使用または誤用、事故、未認可のアクセサリーの接続、製品の改造、またはその他SOL REPUBLICの管理の及ばないあらゆる状況により生じた損傷については適用されません。

품질보증서

SOL REPUBLIC에서는 본 제품을 구입한 시점으로부터 2년간 재료 및 제작기 술면에서 결함이 없음을 보장합니다. 본 품질보증서는 오용 또는 남용, 사고, 일체의 미승인 액세서리 사용, 제품 변경 또는 SOL REPUBLIC의 통제 범위를 넘어선 그 외 일체의 조건으로 인하여 발생한 피해에 대하여 어떠한 책임도 지지 않습니다.



To prevent possible hearing damage, do not listen at high volume levels for long periods.

Con el fin de evitar lesiones auditivas, se aconseja no escuchar a un volumen excesivamente alto durante un periodo prolongado.

Afin d'éviter tout dommage auditif possible, ne pas écouter à un volume sonore élevé pendant une

période prolongée.

Um mögliche Hörschäden zu vermeiden, stellen Sie die Lautstärke nicht über einen längeren Zeitraum sehr hoch ein.

Per evitare possibili danni all'udito, non ascoltare audio a livelli elevati di volume per lunghi periodi



WEEE EXPLANATION

This marking indicates that this product should not be disposed with other household wastes throughout the EU. To prevent possible harm to the environment or human health from uncontrolled waste disposal, recycle it responsibly to promote the sustainable reuse of material resources. To return your used device, please use the return and collection systems or

contact the retailer where the product was purchased. They can take this product for environmental saferecycling.

DECLARACIÓN DE LA DIRECTIVA DE RESIDUOS DE APARATOS ELÉCTRICOS Y ELECTRÓNICOS (WEEE)

Este símbolo indica que este artículo no se debe tirar a la basura con otros residuos domésticos en ningún lugar de la UE. A fin de prevenir los efectos perjudiciales que la eliminación sin control de los residuos puede tener sobre el medio ambiente o la salud de las personas, le rogamos que los recicle de forma responsable para fomentar la reutilización sostenible de los recursos materiales. Para devolver su dispositivo usado, utilice los sistemas de devolución y recogida o póngase en contacto con la empresa a la que le compró el artículo, la cual lo podrá recoger para que se recicle de

forma segura para el medio ambiente.

EXPLICATION WEEE

Le symbole indique que le produit ne doit pas être éliminé avec les autres déchets ménagers dans toute l'Union Européenne. L'élimination incontrôlée des déchets pouvant porter préjudice à l'environnement ou à la santé humaine, veuillez le recycler de façon responsable. Vous favoriserez ainsi la réutilisation durable des ressources matérielles. Pour renvoyer votre appareil usagé, prière d'utiliser le système de renvoi et collection ou contacter le revendeur où le produit a été acheté. Ils peuvent se débarrasser de ce produit afin qu'il soit recyclé tout en respectant l'environnement.

WEEE ERKLÄRUNG

Diese Kennzeichnung weist darauf hin, dass dieses Produkt innerhalb der EU nicht mit anderem Hausmüll entsorgt werden soll. Damit durch unkontrollierte Abfallentsorgung

verursachte mögliche Umwelt- oder Gesundheitsschäden verhindert werden können, entsorgen Sie dieses Produkt bitte ordnungsgemäß und fördern Sie damit eine nachhaltige Wiederverwendung der Rohstoffe. Verwenden Sie zur Rückgabe Ihres benutzten Geräts bitte für die Entsorgung eingerichtete Rückgabe- und Sammelsysteme oder wenden Sie sich an den Händler, bei dem Sie das Produkt kauften. Auf diese Weise kann ein sicheres und umweltfreundliches Recycling gewährleistet werden.

SPIEGAZIONE DIRETTIVA RAEE

Questo simbolo indica che il prodotto non deve essere smaltito assieme agli altri rifiuti domestici in tutti i Paesi dell'Unione Europea. Al fine di evitare un eventuale danno ambientale e alla salute umana derivante dallo smaltimento dei rifiuti non controllato, riciclare il prodotto in maniera

responsabile per promuovere il riutilizzo sostenibile delle risorse materiali. Per la restituzione del dispositivo usato, utilizzare gli appositi sistemi di restituzione e raccolta oppure contattare il rivenditore presso cui il prodotto è stato acquistato, che norme di sicurezza ambientale.

WEEE FORKLARING

Denne afmærkning angiver, at dette produkt ikke må bortskaffes med andet husholdningsaffald inden for EU. For at forhindre mulig skade for miljøet eller menneskers sundhed på grund af ukontrolleret affaldsbortskaffelse, skal det genanvendes på ansvarlig vis for at fremme den bæredygtige genanvendelse af materielle ressourcer. Gør brug af returnerings- og indsamlingsystemer eller kontakt den detailhandler, hvor produktet blev købt, for at returnere det brugte produkt. Disse kan videresende produktet til

miljøsikker genanvendelse.

VYSVĚTLENÍ OEEZ

Tato značka udává, že výrobek nesmí být na území EU vyhazován s běžným domácím odpadem. Pro prevenci možného znečištění životního prostředí a újmě na zdraví osob nekontrolovaným odpadem recyklujte výrobek odpovédným způsobem, který podporuje obnovitelné použití surovin. Pokud chcete použítý výrobek vrátit, využijte prosím sběrného systému nebo se obraťte na prodejce, od kterého jste výrobek zakoupili. Ti mohou výrobek recyklovat způsobem bezpečným pro životní prostředí.

WEEE-MAGYARÁZAT

Ez a jelölés azt jelzi, hogy ezt a terméket az Európai Unióban nem szabad a háztartási hulladék közé dobni. Az ellenőrizetlen hulladékkezelésből származó környezeti vagy egészségügyi kár elkerülése végett, és a tárgyi készletek

fenntartható kezelése jegyében felelősségteljesen hasznosítsa újra. A használt eszköz visszaküldéséhez kérjük, használja a visszaküldő és gyűjtő rendszereket, vagy lépjen kapcsolatba azzal a forgalmazóval, ahonnan a készüléket vásárolta. A terméket ezek a szolgáltatók környezetvédelmileg biztos újrahasznosító helyre viszik.

OBJAŚNIENIE WEEE

Ten znak wskazuje, że na obszarze UE przyrządu nie wolno pozbywać się wyrzucając do śmieci domowych. Aby chronić środowisko i zdrowie, którym zagraża nieodpowiednia utylizacja odpadów, przyrząd należy recyklingować, aby umożliwić odzysk materiałów, z których został wykonany. Aby dokonać zwrotu zużytego przyrządu, należy skorzystać z programów zwrotu i odbioru lub skontaktować punkt zakupu urządzenia. Produkt zostanie odebrany

do bezpiecznego dla środowiska recyklingu.

WEEE POPIS

Tento symbol znamená, že výrobok by sa v rámci celej EU nemá vyhadzovať do domáceho odpadu. Aby nedošlo k možnému znečisteniu životného prostredia alebo poškodeniu zdravia v dôsledku nekontrolovaného odpadu, je potrebné pristupovať k recyklovaniu zodpovedne a propagovať tak opätovné použitie zdrojových materiálov. Ak chcete výrobok vrátiť, postupujte podľa systému na vrátenie a zber alebo kontaktujte predajcu, kde ste výrobok kúpili. Výrobok od vás prevezmú a bezpečne ho recyklujú.

ПОЯСНЕНИЕ WEEE

Данная маркировка означает, что в странах Европы не допускается утилизировать прибор вместе с другими бытовыми отходами. Чтобы не нанести ущерб окружающей среде и здоровью

населения в результате неверной утилизации отходов, прибор следует сдать на переработку, чтобы обеспечить экологичное повторное использование материальных ресурсов. Верните бывший в употреблении прибор через систему возврата и сбора отходов или свяжитесь с предприятием розничной торговли, где вы приобрели прибор. Там вы сможете сдать этот продукт для экологически безопасной переработки.

UITLEG OVER AEEA

Deze markering geeft aan dat dit product binnen de EU niet met ander huisvuil mag worden weggeworpen. Om eventuele schade aan het milieu of de menselijke gezondheid door het ongecontroleerd wegwerpen van afval te voorkomen, dient dit apparaat op verantwoorde wijze gerecycled te worden om duurzaam hergebruik

van materiaalbronnen te bevorderen. Wilt u het gebruikte apparaat retourneren, gebruik dan de retour- en ophaalsystemen of neem contact op met de winkelier waar het product gekocht is. Deze zal het product voor milieuveilige recycling accepteren.

WEEE FORKLARING

Denne merkingen indikerer at innen EU skal dette produktet ikke kastes sammen med annet husholdningsøppel. For å forebygge mulig skade på miljøet eller menneskelig helse forårsaket av ukontrollert avfallstømming, skal produktet gjenvinnes ansvarlig for å støtte holdbar gjenbruk av materialressurser. For å returnere den brukte anordningen, vennligst bruk retur- og hentesystemet, eller ta kontakt med detaljisten hvor produktet ble kjøpt. De kan sørge for miljøvennlig gjenvinning av produktet.

WEEE-SELITYS

Tämä merkki tarkoittaa, että tätä tuotetta ei saa hävittää muiden talousjätteiden mukana missään EU-maassa. Kontrolloimattomasta jätteiden hävittämisestä mahdollisesti aiheutuvien ympäristöhaittojen tai terveysvaarojen estämiseksi hävitä tämä tuote vastuullisesti edistääksesi materiaalivarojen uudelleenkäyttöä. Palauta käytetty laite käyttäen palautus- ja noutojärjestelmää tai ota yhteyttä laitteen myyneeseen liikkeeseen. He voivat kierrättää tämän tuotteen ympäristöturvallisesti.

WEEE-FÖRKLARING

Denna markering indikerar att denna produkt inte får avyttras med annat hushållsavfall inom EU. För att förhindra möjlig skada på miljö eller person från okontrollerat avfallsavyttrande, återvinn på ansvarsfullt vis för att främja det fortsatta återanvändandet av materialresurser. För att returnera

din använda enhet, använd retur och insamlingssystemen eller kontakta återförsäljaren där produkten köptes. De kan se till att produkten återvinns på ett miljösäkert vis.

ΕΠΕΞΗΓΗΣΗ ΑΗΗΕ

Αυτή η σήμανση επισημαίνει ότι αυτό το προϊόν δεν πρέπει να απορρίπτεται με άλλα οικιακά απόβλητα σε όλη την ΕΕ. Για να μην προκληθεί ζημιά στο περιβάλλον ή στην υγεία λόγω μη ελεγχόμενης απόρριψης αποβλήτων, ανακυκλώστε το υπεύθυνα, προάγοντας τη βιώσιμη επαναχρησιμοποίηση των υλικών πόρων. Για να επιστρέψετε τη χρησιμοποιημένη συσκευή, χρησιμοποιήστε τα συστήματα επιστροφής και συλλογής ή επικοινωνήστε με το κατάστημα από το οποίο αγοράσατε το προϊόν. Οι υπεύθυνοι μπορούν να παραλάβουν αυτό το προϊόν για ασφαλή για το περιβάλλον ανακύκλωσή του.

EXPLICAÇÃO WEEE

Esta marcação indica que o produto não deve ser eliminado juntamente com outros resíduos domésticos em toda a UE. Para impedir possíveis danos ambientais ou à saúde humana resultantes de uma eliminação não controlada dos resíduos, este produto deverá ser reciclado de forma responsável de modo a promover a reutilização sustentável dos recursos materiais. Para fazer a devolução do seu dispositivo usado, queira por favor utilizar os sistemas de devolução e recolha ou contactar a loja onde adquiriu o produto. A loja poderá entregar este produto para que seja reciclado de forma segura em termos ambientais.

WEEE AÇIKLAMASI

Bu işaret bu ürünün AB genelinde diğer ev atıklarıyla birlikte atılmaması gerektiğini belirtir. Kontrolsüz atığın çevre veya insan sağlığına olası

zararları engellemek için sorumlu bir şekilde geri dönüştürülmesini ve malzeme kaynaklarının sürdürülebilir şekilde yeniden kullanılmasını sağlayın. Kullanılmış aygıtınızı iade etmek için lütfen iade sistemlerini kullanın veya ürünü satın aldığınız perakende satış noktasıyla görüşün. Kendileri bu ürünü çevreye zarar vermeyecek şekilde geri dönüştürülmek üzere gerekli yere gönderebilirler.



BATTERY DIRECTIVE

This symbol indicates that batteries must not be disposed of in the domestic waste as they contain substances which can be damaging to the environment and health. Please dispose of batteries in designated collection points.

DIRECTIVA RELATIVA A LAS PILAS

Este símbolo indica que las pilas no se deben eliminar con la basura doméstica ya que contienen sustancias que pueden ser perjudiciales para el medio ambiente y la salud. Deshágase de las pilas en los puntos de recogida que existen para ese fin.

DIRECTIVE RELATIVE AUX PILES ET AUX ACCUMULATEURS

Ce symbole indique que les piles et les accumulateurs ne doivent pas être jetés avec les déchets ménagers car ils contiennent des substances pouvant être préjudiciables pour la santé humaine et l'environnement. Veuillez utiliser les points de collecte mis à disposition pour vous débarrasser des piles et accumulateurs usagés.

Avertissement : Toujours insérer les piles correctement concernant

les polarités (+ et -) marquées sur la pile et l'équipement. Ne pas laisser les enfants effectuer de remplacement de pile sans la surveillance d'un adulte. Maintenir les piles hors de portée des enfants. En cas d'ingestion d'un élément ou d'une pile, il convient que la personne concernée consulte rapidement un médecin. Ne pas mettre au rebut les piles dans le feu. Ne pas charger les piles. Ne pas court-circuiter les piles. Il convient d'enlever immédiatement les piles mortes de l'équipement et de les mettre convenablement au rebut. Ne pas déformer les piles. Information à conserver avec la notice. Ne pas mélanger des piles anciennes et neuves ou des piles de différents types ou marques. Enlever les piles de l'équipement s'il ne doit pas être utilisé pendant une période de temps prolongée, sauf si l'on prévoit des cas d'urgence. Ne pas chauffer les piles. Ne pas forcer la décharge des piles.

BATTERIE RICHTLINIE

Dieses Symbol weist darauf hin, dass die Batterien nicht mit dem gewöhnlichen Hausmüll entsorgt werden dürfen, da sie Stoffe enthalten, die sich auf Umwelt und Gesundheit schädlich auswirken können. Entsorgen Sie die Batterien bitte an den hierfür vorgesehenen Sammelstellen.

DIRETTIVA RELATIVA ALLE BATTERIE

Questo simbolo indica che le batterie devono essere smaltite separatamente dai rifiuti domestici poiché contengono sostanze potenzialmente nocive per l'ambiente e la salute umana. Smaltire le batterie negli appositi centri di raccolta.

BATTERIDIREKTIV

Dette symbol indikerer, at batterier ikke må bortskaffes med husholdningsaffald, da de indeholder stoffer, der kan være miljø- og

helbredsskadelige. Bortskaf venligst batterier på udpegede indsamlingssteder.

ELEMEKRE VONATKOZÓ IRÁNYELV

Ez a szimbólum azt jelzi, hogy az elemek nem dobhatók háztartási hulladék közé, mivel olyan anyagokat tartalmaznak, amelyek károsak lehetnek a környezetre és az egészségre. Kérjük, vigye a használt elemeket a kijelölt gyűjtőhelyre.

DYREKTYWA DOT. BATERII

Ten symbol oznacza, że baterii nie można wyrzucać wraz z odpadami domowymi, ponieważ baterie zawierają substancje, które mogą być szkodliwe dla środowiska oraz zdrowia. Baterie należy dostarczyć do wyznaczonych punktów zbiórki.

POKYNY OHĽADNE BATÉRIE

Tento znak znamená, že batérie sa nesmú likvidovať spolu s domácim odpadom, pretože obsahujú látky,

ktoré môžu znečistiť životné prostredie alebo poškodiť zdravie. Batérie likvidujte v strediskách určených pre zber odpadu.

ИНСТРУКЦИИ К БАТАРЕЯМ

Данный символ означает, что батареи не следует утилизировать совместно с бытовым мусором, поскольку они содержат вещества, способные нанести вред окружающей среде и здоровью. Утилизируйте батареи в специально предназначенных для этого приемных пунктах.

RICHTLIJN INZAKE BATTERIJEN

Dit symbool betekent dat batterijen niet met het huisvuil weggegooid mogen worden, omdat ze stoffen bevatten die schadelijk kunnen zijn voor het milieu en de gezondheid. Lever batterijen op een aangewezen inzamelpunt in.

BATTERIDIREKTIV

Dette symbolet indikerer at batteriene

ikke må kastes sammen med vanlig husholdningsavfall da de inneholder substanser som kan skade miljøet og helsen. Vær vennlig å kaste batterier i angitte oppsamlingspunkter.

BATTERIFÖRESKRIFT

Denna symbol indikerar att batterier inte får avyttras bland hushållssopor eftersom de innehåller substanser som kan skada miljön och hälsan. Avyttra batterier endast vid designerade insamlingspunkter.

ΟΔΗΓΙΑ ΓΙΑ ΤΙΣ ΜΠΑΤΑΡΙΕΣ

Το σύμβολο αυτό υποδεικνύει ότι οι μπαταρίες δεν πρέπει να απορρίπτονται μαζί με οικιακά απορρίμματα, καθώς περιέχουν ουσίες που μπορεί να είναι επιβλαβείς για το περιβάλλον και την υγεία. Απορρίψτε τις μπαταρίες στα καθορισμένα σημεία συλλογής.

INSTRUÇÕES RELATIVAMENTE ÀS PILHAS

Este símbolo indica que as pilhas não

podem ser eliminadas juntamente com o lixo doméstico, dado que contêm substâncias que podem ser prejudiciais para o meio ambiente e a saúde. As pilhas devem ser eliminadas nos pontos de recolha designados.

PIL DIREKTIFI

Bu sembol, çevreye ve sağlığa karşı zararlı olabilen maddeler içerebileceği için pillerin ev atığıyla atılmaması gerektiği gösterir. Lütfen, pilleri belirtilen toplama noktalarına atın.

FCC WARNING:

This device complies with Part 15 of the FCC Rules. Operation is subject to the following two conditions: (1) this device may not cause harmful interference, and (2) this device must accept any interference received, including interference that may cause undesired operation.

Any changes or modifications not expressly approved by the party responsible for compliance could void the user's authority to operate the equipment.

Note: This equipment has been tested and found to comply with the limits for a Class B digital device, pursuant to part 15 of the FCC Rules. These limits are designed to provide reasonable protection against harmful interference in a residential installation. This equipment generates, uses and can radiate radio frequency energy and, if not installed and used in accordance with the instructions, may cause harmful interference to radio communications. However, there is no guarantee that interference will not occur in a particular installation. If this equipment does cause harmful interference to radio or television reception, which can be determined by turning the equipment off and on,

the user is encouraged to try to correct the interference by one or more of the following measures:

- Reorient or relocate the receiving antenna.
- Increase the separation between the equipment and receiver.
- Connect the equipment into an outlet on a circuit different from that to which the receiver is connected.
- Consult the dealer or an experienced radio/TV technician for help.

This equipment complies with FCC radiation exposure limits set forth for an uncontrolled environment. This transmitter must not be co-located or operating in conjunction with any other antenna or transmitter.

ISED WARNING:

This device complies with Innovation, Science, and Economic Development Canada license-exempt

RSS standard(s). Operation is subject to the following two conditions: (1) this device may not cause interference, and (2) this device must accept any interference, including interference that may cause undesired operation of the device.

Le présent appareil est conforme aux CNR d'Innovation, Sciences et Développement économique Canada applicables aux appareils radio exempts de licence. L'exploitation est autorisée aux deux conditions suivantes: (1) l'appareil ne doit pas produire de brouillage, et (2) l'utilisateur de l'appareil doit accepter tout brouillage radioélectrique subi, même si le brouillage est susceptible d'en compromettre le fonctionnement.

ISED RADIATION EXPOSURE STATEMENT:

The device is compliance with RF exposure guidelines, users can obtain Canadian information on RF exposure

and compliance. Le présent appareil est conforme Après examen de ce matériel aux conformité ou aux limites d'intensité de champ RF, les utilisateurs peuvent sur l'exposition aux radiofréquences et la conformité and compliance d'acquiescer les informations correspondantes. compromettre le fonctionnement.

DECLARATION OF CONFORMITY

EN

Hereby, FKA Brands Ltd., declares that this radio equipment is in compliance with the essential requirements and other relevant provisions of Directive 2014/53/EU. A copy of the Declaration of Conformity can be obtained from www.solrepublic.co.uk/declaration-of-conformity

IT

Con la presente, FKA Brands Ltd., dichiara che l'apparecchiatura radio in oggetto

è conforme ai requisiti essenziali e ad altre disposizioni pertinenti della Direttiva 2014/53/EU. È possibile richiedere una copia della Dichiarazione di conformità scrivendo all'indirizzo www.solrepublic.co.uk/declaration-of-conformity

DE

Hiermit erklärt die FKA Brands Ltd., dass dieses Funkgerät in Übereinstimmung mit den wesentlichen Anforderungen und anderen entsprechenden Bestimmungen der Richtlinie 2014/53/EU geliefert wird. Eine Kopie der Konformitätserklärung ist über www.solrepublic.co.uk/declaration-of-conformity

FR

FKA Brands Ltd. déclare par la présente que cet équipement radio est conforme aux exigences essentielles et autres dispositions pertinentes de la Directive 2014/53/EU. Pour obtenir un exemplaire de la Déclaration de conformité, s'adresser à

www.solrepublic.co.uk/declaration-of-conformity

ES

Por la presente, FKA Brands Ltd. declara que este dispositivo de radio está en conformidad con los requisitos esenciales y otras disposiciones relevantes de la directiva 2014/53/EU. Si desea una copia de la declaración de conformidad, solicítela a www.solrepublic.co.uk/declaration-of-conformity

PT

Desta forma, o FKA Brands Ltd., declara que este equipamento de rádio está em conformidade com os requisitos essenciais outras provisões relevantes da Diretiva 2014/53/EU. É possível obter uma cópia da Declaração de Conformidade através do www.solrepublic.co.uk/declaration-of-conformity

NL

Hierbij verklaart FKA Brands Ltd. dat

deze radioapparatuur voldoet aan de essentiële vereisten en andere relevante voorschriften van Directive 2014/53/EU. Een kopie van de conformiteitsverklaring kan worden verkregen via www.solrepublic.co.uk/declaration-of-conformity

HU

A FKA Brands Ltd.. kijelenti, hogy ez a rádióberendezés eleget tesz a 2014/53/EU irányelv szükséges követelményeinek és egyéb vonatkozó rendelkezéseinek. A Megfelelőségi nyilatkozat másolatát a www.solrepublic.co.uk/declaration-of-conformity

CZ

Společnost FKA Brands Ltd. tímto prohlašuje, že toto rádiové vybavení je ve shodě se základními požadavky a dalšími relevantními ustanoveními směrnice 2014/53/EU. Kopii prohlášení o shodě získáte na adrese www.solrepublic.co.uk/declaration-of-conformity

SK

Spoločnosť FKA Brands Ltd. týmto vyhlasuje, že toto rádiové zariadenie je v súlade so základnými požiadavkami a ďalšími relevantnými ustanoveniami Smernice 2014/53/EÚ. Kópiu vyhlásenia o zhode získate na adrese www.solrepublic.co.uk/declaration-of-conformity

PL

Niniejszym firma FKA Brands Ltd. oświadcza, że to urządzenie radiowe jest zgodne z podstawowymi wymaganiami oraz innymi właściwymi postanowieniami Dyrektywy 2014/53/EU. Kopię Deklaracji zgodności można uzyskać pod www.solrepublic.co.uk/declaration-of-conformity

TR

İş bu vesileyle, FKA Brands Ltd., bu tesisiz ekipmanının 2014/53/EU Yönergesinin temel gereksinimleri ve diğer ilgili hükümleriyle uyumlu olduğunu beyan

eder. Uygunluk Beyanı'nın bir kopyası www.solrepublic.co.uk/declaration-of-conformity

RU

Компания FKA Brands Ltd. настоящим подтверждает соответствие данного радиооборудования основным требованиям и другим применимым положениям Директивы 2014/53/EU. Копия Декларации соответствия можно получить по электронному адресу: www.solrepublic.co.uk/declaration-of-conformity

NO

FKA Brands Ltd., erklærer herved at dette radioutstyret samsvarer med nødvendige krav og andre relevante forholdsregler i direktiv 2014/53/EU. En kopi av konformitetserklæringen er tilgjengelig fra www.solrepublic.co.uk/declaration-of-conformity

DK

FKA Brands Ltd. erklærer hermed, at dette radioudstyr efterlever de essentielle krav og andre relevante bestemmelser i Direktiv 2014/53/EU. En kopi af Overensstemmelseserklæringen kan fås hos www.solrepublic.co.uk/declaration-of-conformity

SV

Härmed deklarerar FKA Brands Ltd. att denna radioutrustning är förenlig med nödvändiga krav och andra relevanta bestämmelser i direktivet 2014/53/EU. En kopia av förenlighetsdeklarationen kan erhållas från www.solrepublic.co.uk/declaration-of-conformity

FI

FKA Brands Ltd. vakuuttaa, että tämä radiolaite on direktiivin 2014/53/EU vaatimusten ja muiden siihen liittyvien säädösten mukainen. Kopion vaatimustenmukaisuusvakuutuksesta voi tilata

lähettämällä sähköpostia osoitteeseen
www.solrepublic.co.uk/declaration-of-conformity

EL

Με το παρόν, η FKA Brands Ltd. δηλώνει ότι αυτός ο ασύρματος εξοπλισμός συμμορφώνεται με τις ουσιώδεις απαιτήσεις και τις άλλες σχετικές προβλέψεις της Οδηγίας 2014/53/EU. Μπορείτε να αποκτήσετε ένα αντίγραφο της Δήλωσης Συμμόρφωσης αν επικοινωνήσετε με τη διεύθυνση www.solrepublic.co.uk/declaration-of-conformity

العربية

تقر FKA Brands Ltd. بموجبه أن هذا الجهاز اللاسلكي يأتي متوافقاً مع المتطلبات اللازمة وغيره من الأحكام ذات الصلة من الأمر الإرشادي 2014/53/EU. ويمكن الحصول على نسخة من إعلان المطابقة على

www.solrepublic.co.uk/declaration-of-conformity

WARNING: Batteries (battery pack or batteries installed) shall not be exposed to excessive heat such as sunshine, fire or the like.

ADVERTENCIA: Las pilas (batería o pilas instaladas) no se deben exponer a una fuente de calor excesivo, como la luz solar, el fuego o similar.

AVERTISSEMENT : Les batteries (la batterie ou les piles installées) ne doivent pas être exposées à une chaleur excessive (soleil, feu ou autre).

WARNHINWEIS: Batterien (Akkus oder eingebaute Batterien) dürfen nicht übermäßiger Wärme, wie direkter Sonneneinstrahlung, Feuer oder dergleichen ausgesetzt werden.

AVVERTENZA: Non esporre le batterie (alimentatore o batterie installate) a calore eccessivo, come ad esempio luce solare, fuoco o simili fonti di calore.

ADVASEL: Batterier (batteripakke eller isatte batterier) må ikke udsættes for kraftig varme såsom solskin, ild eller lignende.

VAROVÁNÍ: Baterie (nainstalovaná sada

baterii nebo baterie) nesmí být vystaveny nadměrnému teplu, například slunečnímu záření, ohni a podobně.

FIGYELEM: Az akkumulátort (akkumulátorok vagy beépített akkumulátor) nem szabad túlzott hőhatásnak, például napsütésnek, tűznek vagy hasonló hatásnak kitenni.

OSTRZEŻENIE! Baterii (zestawu baterii lub dostarczonych baterii przez producenta) nie należy wystawiać na działanie nadmiernego ciepła, takiego jak promienie słoneczne, pożar lub podobne źródła ciepła.

VAROVANIE: Batérie (balenie batérií alebo nainštalované batérie) nesmú byť vystavené nadmernému teplu, napríklad slnečnému žiareniu, ohňu a podobne.

ВНИМАНИЕ! Не допускайте воздействия на батареи (батареиный отсек или установленные батареи) источников избыточного нагрева: прямых солнечных лучей, огня и т. п.

VAROVANIE: Batérie (balenie batérií alebo nainštalované batérie) nesmú byť

vystavené nadmernému teplu, napríklad slnečnému žiareniu, ohňu a podobne.

WAARSCHUWING! Batterijen (accu of geïnstalleerde batterijen) mogen niet worden blootgesteld aan overmatige warmte, zoals zonlicht, vuur of soortgelijke dingen.

ADVASEL: Batterier (batteripakke eller installerte batterier) skal ikke utsettes for sterk varme, slik som solskinn, brann eller lignende.

VAROITUS: Akkuja (akkuyksikkö tai asennetut akut) ei saa altistaa liialliselle kuumuudelle, kuten auringonvalo, tulipalo, tms.

WARNING: Batterier (nätandel eller installerade batterier) inte får utsättas för överdriven värme såsom solsken, eld eller liknande.

ΠΡΟΕΙΔΟΠΟΙΗΣΗ: Οι μπαταρίες (κλειστή μπαταρία ή εγκατεστημένες μπαταρίες) δεν πρέπει να εκτίθενται σε υπερβολική θερμότητα, όπως απευθείας ηλιακό φως, φωτιά ή όμοιες συνθήκες.

ADVERTÈNCIA: As pilhas (fonte de

alimentação ou pilhas instaladas) não devem ser sujeitas a calor excessivo, designadamente através de exposição ao sol, fogo ou outras fontes de calor semelhantes.

UYARI: Piller (pil paketi ya da takılı piller) güneş ışığı, ateş ya da benzeri aşırı ısı kaynaklarına maruz bırakılmamalıdır.

RESOLUÇÃO 506

Este equipamento opera em caráter secundário, isto é, não tem direito a proteção contra interferência prejudicial, mesmo de estações do mesmo tipo, e não pode causar interferência a sistemas operando em caráter primário.

Warranty & Info



© 2018 SOL REPUBLIC