

June 30, 2005

Antenna Info

This product incorporates a Linx Technologies 418-SP1 monolithic antenna which is permanently soldered to the device circuit board. The gain is -6dBi at 418 MHz.

This product complies with FCC section 15.203 because the antenna is permanently attached to the unit. There is also no provision for replacement of the antenna by either the end-user or manufacturer.



INTRODUCTION

The "SplatCh" is a breakthrough in compact antenna technology. It combines excellent performance and cost-effectiveness into an antenna package that can be integrated, even by designers lacking RF test equipment. Despite its simplicity and ease of use the "SplatCh" should not be thought of as "just any other part". Its correct function is critical to the performance of your overall device. Dropping the "SplatCh" in the center of your board like any popcorn IC will likely yield dismal results. It is critical to follow the guidelines below in order to obtain proper function.

FEATURES:

- Low Cost
- Eliminates unsightly external antennas
- Easily concealed
- Direct PCB mounting
- Reflow compatible
- Stable grounded-line element
- Excellent proximity performance
- 10MHz approximate useable bandwidth

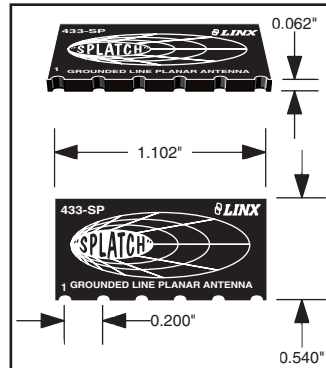

Physical Dimensions

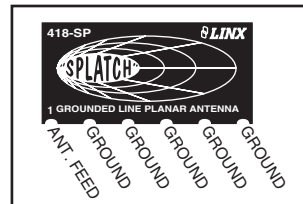

Electrical Connections

APPLICATIONS INCLUDE:

- Remote control
- Keyless entry
- Garage / Gate openers
- Lighting control
- Medical monitoring
- Remote data transfer
- Fire / Security systems
- RFID
- Pagers

ORDERING INFORMATION

PART #	DESCRIPTION
ANT-***-SP	SplatCh Planar Antenna
***= 315, 418, 433, 868, 916	
Custom frequencies available with NRE.	
SplatCh antennas are supplied in tube packaging - 20 pcs. per tube.	
Tape and reel available at extra cost on request.	

ATTACHMENT

The antenna pads are designed to support both hand and automated placement. Castellations have been provided to ease solder introduction during hand assembly. The parts are also fully compatible with the reflow process for automated assembly.

APPLICATION CONSIDERATIONS

When implemented correctly the “Splatch” will yield outstanding and repeatable results. However, the “Splatch” was designed with very specific feed and mounting requirements. Failure by the designer to respect these requirements will result in unsatisfactory performance.

* The antenna is tuned for direct mounting to a product’s PCB. Mounting the antenna in any other manner will produce poor results.

* The antenna should be fed with a trace $\leq .25"$. Longer runs or coax feeds are not recommended.

* Nothing should be placed under or directly beside the antenna element. Generally, mounting the antenna at the front of a product as illustrated will yield the best results.

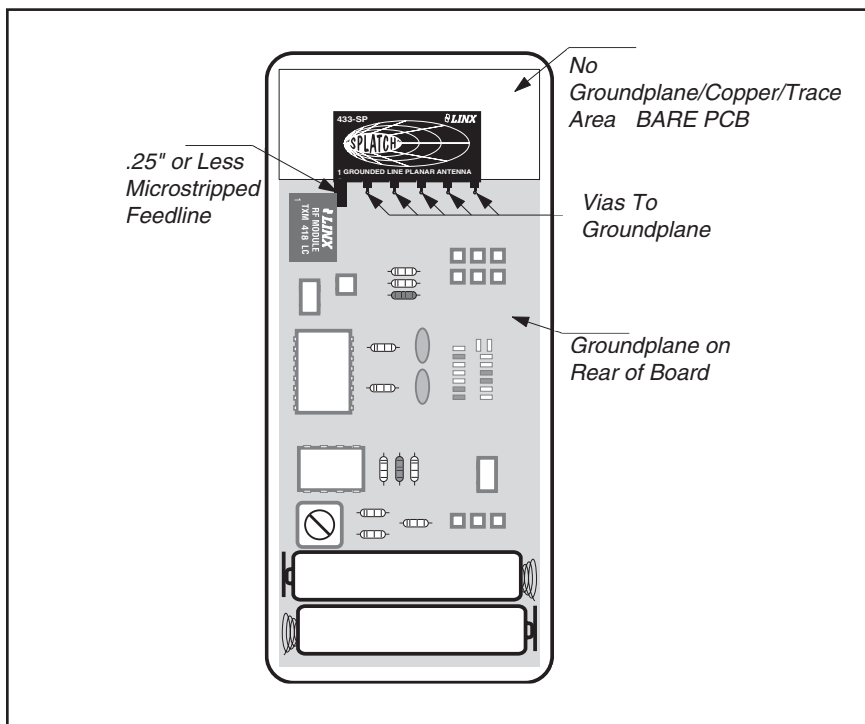

Typical Remote Control Application

FEED CONSIDERATIONS

Like most reduced-size antennas the “Splatch” has a fairly high Q and thus exhibits narrow bandwidth characteristics. The single most critical element in insuring the optimum function of the “Splatch” is to minimize the length of the feed trace (Transmission Line) to the “Splatch” itself. The feed trace should be less than $.25"$ and in all cases microstripped. The term “Microstrip” refers to a trace passed over groundplane of a width appropriate to create a 50-ohm transmission line between the module and the antenna. Since the antenna does not present a true and stable 50-ohm match, the feed trace tends to lower the antenna’s resonant frequency. Given the antenna’s narrow bandwidth, it can easily be detuned by the length of the feed trace; thus, the trace should be kept as short as possible. Additional microstrip details are available in the reference section of this guide

LAYOUT CONSIDERATIONS

Improper placement of planes, traces or components will result in antenna nulls or complete detuning. First, the area under the antenna on all board layers should be completely free of components, traces, or groundplane. In addition, no components or traces should pass within $.25"$ of the top, sides, front or back of the antenna. Ideally the antenna will be mounted at the top of the board and given an unobstructed field of view in all directions. Components placed in the area below the back edge of the antenna will have little effect since the antenna has a null at its back edge when referenced appropriately to groundplane. Components placed to the sides or top of the antenna or items such as displays mounted in proximity to the antenna will produce nulls and, possibly, detuning. The antenna may be referenced to groundplanes of all different surface areas; however, it has been optimized for a $1.5" \times 3"$ plane area. The best performance and lowest VSWR will be obtained when referenced to a plane of similar area.

The recommended pad layout is illustrated below. The top layer of the board generally has the antenna mounting pads and feed trace. The ground pads are connected to the groundplane layer through vias. Use care in the sizing and placement of the vias to prevent solder migration from the attachment pads during attachment.

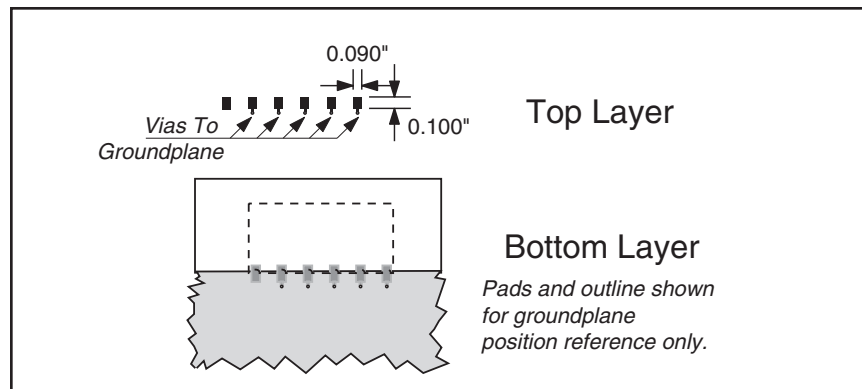

SPLATCH SERIES PERFORMANCE DATA

About These Measurements

The typical performance graphs below were based on a "Splatch" antenna affixed to the test jig illustrated, and measured with a HP-8753D network analyzer in a 20°-25°C environment.

**As of the time of this publication, full pattern characterization data was not available. Refer to the Linx website for periodic updates to this document.*

Specification	Frequency					Units	Notes
	315	418	433.92	868	900		
Electrical Length	1/4λ	1/4λ	1/4λ	1/4λ	1/4λ	MHz	
Center Frequency	315	418	433.92	868	916	MHz	1
Useable Bandwidth	10	10	10	20	40	MHz	
Characteristic Impedence	50	50	50	50	50	Ohms	1, 2
VSWR	<1.7 Typ.	<1.7 Typ.	<1.7 Typ.	<1.7 Typ.	<1.7 Typ.		1
Gain/Loss>	-10	-6	-5	-2	-1		1, 3, 4

Notes:

1. At Specified Frequency; 2. VSWR <2.0; 3. Relative to isotropic; 4. Preliminary

TYPICAL SMITH CHART

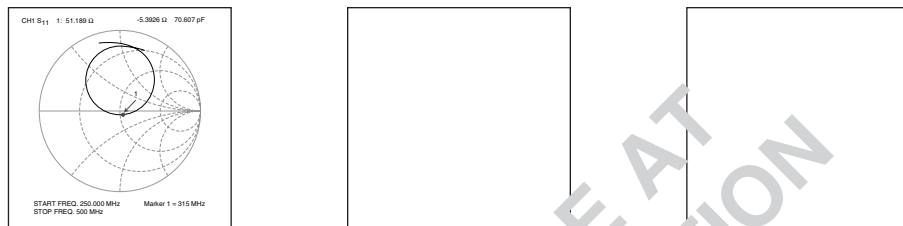

TYPICAL VSWR GRAPHS

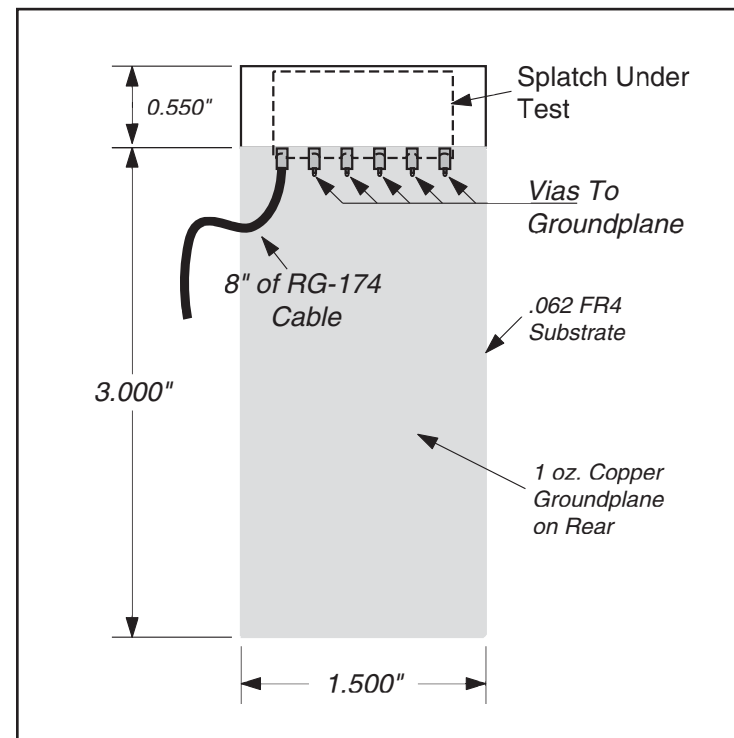
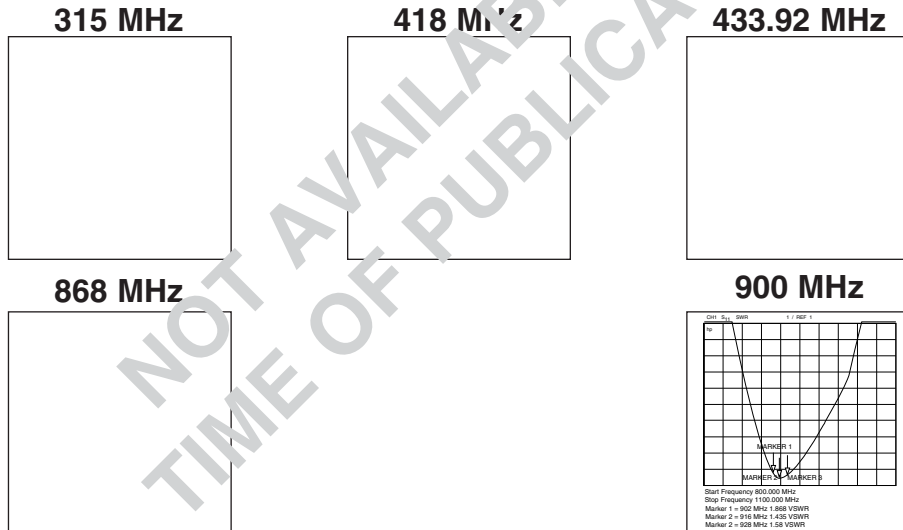

TESTING

Several methods may be employed to verify the optimization of the "Splatch" in your product design. They are listed below in order of preference.

- Utilize a network analyzer to verify resonance and VSWR.
- Use a Spectrum Analyzer and Signal Generator to sweep the antenna and find the frequency of highest output.

NOTE A characterized or calibrated antenna must be used on the Spectrum Analyzer in order for meaningful results to be obtained.

- Test range results in your environment. If your product performs to your requirements, cease all engineering efforts and sell it.



MISMATCH CONVERSION TABLE

VSWR	Insertion Loss (dB)	Power Transmitted (%)	Power Reflected (%)
17.391	-6.87	20.57%	79.43%
11.610	-5.35	29.21%	70.79%
8.724	-4.33	36.90%	63.10%
6.997	-3.59	43.77%	56.23%
5.848	-3.02	49.88%	50.12%
5.030	-2.57	55.33%	44.67%
4.419	-2.20	60.19%	39.81%
3.946	-1.90	64.52%	35.48%
3.570	-1.65	68.38%	31.62%
3.010	-1.26	74.88%	25.12%
2.615	-0.97	80.05%	19.95%
2.323	-0.75	84.15%	15.85%
2.100	-0.58	87.41%	12.59%
1.925	-0.46	90.00%	10.00%
1.433	-0.14	96.84%	3.16%
1.222	-0.04	99.00%	1.00%
1.119	-0.01	99.68%	0.32%
1.065	0.00	99.90%	0.10%
1.034	0.00	99.97%	0.03%
1.020	0.00	99.99%	0.01%

MICROSTRIP DETAILS

Formula Method

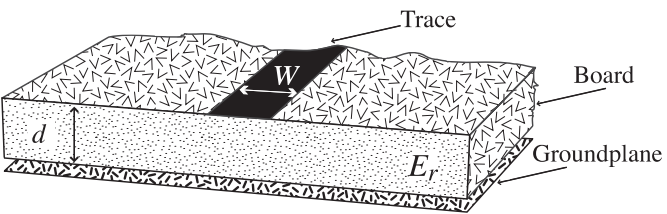

$$E_e = \frac{E_r + 1}{2} + \frac{E_r - 1}{2} \cdot \frac{1}{\sqrt{1 + 12d/W}}$$

$$Z_0 = \begin{cases} \frac{60}{\sqrt{E_e}} \cdot \ln\left(\frac{8d}{W} + \frac{W}{4d}\right) & \text{For } \frac{W}{d} \leq 1 \\ 120\pi \sqrt{E_e} \cdot \left(\frac{W}{d} + 1.393 + 0.667 \cdot \ln\left(\frac{W}{d} + 1.444\right)\right) & \text{For } \frac{W}{d} \geq 1 \end{cases}$$

Dielectric Constant	Width/Height (W/d)	Effective Dielectric Constant	Characteristic Impedance
4.8	1.8	3.59	50.0
4	2	3.07	51.0
2.55	3	2.12	48.0

Microstrip formulas (E_r = Dielectric constant of PCB material)

Power Conversion Tables For 50Ω System

dBm	mW	dBmV	mVRMS	mVp	mVpp
-50	0.000	-3.0	0.7	1.0	2.0
-45	0.000	2.0	1.3	1.8	3.6
-40	0.000	7.0	2.2	3.2	6.3
-35	0.000	12.0	4.0	5.6	11.2
-30	0.001	17.0	7.1	10.0	20.0
-25	0.003	22.0	12.6	17.8	35.6
-20	0.010	27.0	22.4	31.6	63.2
-15	0.032	32.0	39.8	56.2	112.5
-10	0.100	37.0	70.7	100.0	200.0
-5	0.316	42.0	125.7	177.8	355.7
0	1.000	47.0	223.6	316.2	632.5
1	1.259	48.0	250.9	354.8	709.6
2	1.585	49.0	281.5	398.1	796.2
3	1.995	50.0	315.9	446.7	893.4
4	2.512	51.0	354.4	501.2	1002.4
5	3.162	52.0	397.6	562.3	1124.7
6	3.981	53.0	446.2	631.0	1261.9
7	5.012	54.0	500.6	707.9	1415.9
8	6.310	55.0	561.7	794.3	1588.7
9	7.943	56.0	630.2	891.3	1782.5
10	10.000	57.0	707.1	1000.0	2000.0
11	12.589	58.0	793.4	1122.0	2244.0
12	15.849	59.0	890.2	1258.9	2517.9
13	19.953	60.0	998.8	1412.5	2825.1
14	25.119	61.0	1120.7	1584.9	3169.8
15	31.623	62.0	1257.4	1778.3	3556.6
16	39.811	63.0	1410.9	1995.3	3990.5
17	50.119	64.0	1583.0	2238.7	4477.4
18	63.096	65.0	1776.2	2511.9	5023.8
19	79.433	66.0	1992.9	2818.4	5636.8
20	100.000	67.0	2236.1	3162.3	6324.6
21	125.893	68.0	2508.9	3548.1	7096.3
22	158.489	69.0	2815.0	3981.1	7962.1
23	199.526	70.0	3158.5	4466.8	8933.7
24	251.189	71.0	3543.9	5011.9	10023.7
25	316.228	72.0	3976.4	5623.4	11246.8
26	398.107	73.0	4461.5	6309.6	12619.1
27	501.187	74.0	5005.9	7079.5	14158.9
28	630.957	75.0	5616.7	7943.3	15886.6
29	794.328	76.0	6302.1	8912.5	17825.0
30	1000.000	77.0	7071.1	10000.0	20000.0



U.S. CORPORATE HEADQUARTERS:

ANTENNA FACTOR, INC.

***575 S.E. ASHLEY PLACE
GRANTS PASS, OR 97526***

Phone: (541) 956-0931

FAX: (541) 471-6251

<http://www.antennafactor.com>

Disclaimer

Antenna Factor is continually striving to improve the quality and function of its products; for this reason, we reserve the right to make changes without notice. The information contained in this Data Sheet is believed to be accurate as of the time of publication. Specifications are based on representative lot samples. Values may vary from lot to lot and are not guaranteed. Antenna Factor makes no guarantee, warranty, or representation regarding the suitability of any product for use in a specific application. None of these devices is intended for use in applications of a critical nature where the safety of life or property is at risk. The user assumes full liability for the use of product in such applications. Under no conditions will Antenna Factor be responsible for losses arising from the use or failure of the device in any application, other than the repair, replacement, or refund limited to the original product purchase price. Some devices described in this publication are patented. Under no circumstances shall any user be conveyed any license or right to the use or ownership of these patents.

© 2004 by Antenna Factor, Inc. The stylized Antenna Factor logo, and Antenna Factor are trademarks of Linx Technologies, Inc.
Printed in U.S.A.