

# **FCC Test Report**

for

## **Contactless Card Reader**

**Trade Name : Uniform**  
**Model Number : UIC683**  
**FCC ID : TFJUIC683**  
**Report Number : RF-U010-0910-144**  
**Date of Receipt : Oct. 12, 2009**  
**Date of Report : Oct. 22, 2009**

Prepared for

### **Uniform Industrial Corp.**

1st. FL,NO.1,Lane 15,Chih Chiang St., Tu Cheng City, Taipei Hsien, Taiwan,R.O.C.

Prepared by



### **Central Research Technology Co.**

#### **EMC Test Laboratory**

No.11, Lane41, Fushuen St., Jungshan Chiu, Taipei, Taiwan, 104, R.O.C.



NVLAP LAB CODE 200575-0

**This report shall not be reproduced, except in full, without the written approval of Central Research Technology Co.. It may be duplicated completely in its entirety for legal use with the permission of the applicant. It should not be used to claim product endorsement by NVLAP or any U.S. government agency. The test result in the report applies only to the sample tested.**

# Certification

**Equipment under Test** : Contactless Card Reader  
**Model No.** : UIC683  
**FCC ID** : TFJUIC683  
**Manufacturer** : Uniform Industrial Corp.  
**Applicant** : Uniform Industrial Corp.  
**Address** : 1st. FL,NO.1,Lane 15,Chih Chiang St., Tu Cheng City, Taipei Hsien, Taiwan,R.O.C.  
**Date of Testing** : Oct. 14, 2009  
**Applicable Standards** : 47 CFR part 15, Subpart C  
**Deviation** : N/A  
**Condition of Test Sample** : Enigneering Sample

We, **Central Research Technology Co.**, hereby certify that one sample of the designated product was tested in our facility during the period mentioned above. The test records, data evaluation and Equipment Under Test (EUT) configurations shown in the present report are true and accurate representation of the measurements of the sample's RF characteristics under the conditions herein specified.

The test results show that the EUT as described in the present report is in compliance with the requirements set forth in the standards mentioned above and apply to the tested sample identified in the present report only. The test report shall not be reproduced, except in its entirety, without the written approval of Central Research Technology Co.

**PREPARED BY** : Cathy Chen , **DATE** : Oct. 23, 2009  
(Cathy Chen/ Technical Manager)

**APPROVED BY** : Sam Chien , **DATE** : Oct. 23, 2009  
(Sam Chien/ Laboratory Head)

## Contents

<b>1</b>	<b>General Description .....</b>	<b>4</b>
1.1	GENERAL DESCRIPTION OF EUT .....	4
1.2	REQUIREMENT FOR COMPLIANCE.....	5
1.3	THE SUPPORT UNITS .....	7
1.4	LAYOUT OF SETUP .....	7
1.5	TEST CAPABILITY .....	7
1.6	MEASUREMENT UNCERTAINTY .....	9
<b>2</b>	<b>Field Strength of fundamental.....</b>	<b>10</b>
2.1	APPLIED STANDARD .....	10
2.2	TEST INSTRUMENTS .....	10
2.3	MEASUREMENT PROCEDURE.....	11
2.4	TEST CONFIGURATION .....	11
2.5	TEST DATA .....	12
<b>3</b>	<b>Radiated Emission .....</b>	<b>16</b>
3.1	APPLIED STANDARD .....	16
3.2	TEST INSTRUMENTS .....	17
3.3	MEASUREMENT PROCEDURE.....	18
3.4	TEST CONFIGURATION .....	19
3.5	TEST DATA .....	20
<b>4</b>	<b>Frequency Tolarence .....</b>	<b>22</b>
4.1	APPLIED STANDARD .....	22
4.2	TEST INSTRUMENTS .....	22
4.3	MEASUREMENT PROCEDURE.....	23
4.4	TEST CONFIGURATION .....	23
4.5	TEST DATA .....	24
<b>5</b>	<b>20dB Bandwidth .....</b>	<b>26</b>
5.1	APPLIED STANDARD .....	26
5.2	TEST INSTRUMENTS .....	26
5.3	MEASUREMENT PROCEDURE.....	27
5.4	TEST CONFIGURATION .....	27
5.5	TEST DATA .....	28

**Attachment 1 – Photographs of the Test Configurations**

**Attachment 2 – External Photographs of EUT**

**Attachment 3 – Internal Photographs of EUT**

## 1 General Description

### 1.1 General Description of EUT

Equipment under Test: Contactless Card Reader

Model No. : UIC683

Power in : Power supplied by the connected PDA

Test Voltage : 5Vdc by the connected PDA

Manufacturer : Uniform Industrial Corp.

Channel Numbers : 1

Frequency Range : 13.56MHz

Function Modulation : FSK

Function Description :

The EUT is used to transmit and receive signal and data both. Please refer to the user's manual for the details.

According to the X, Y, Z Axis preliminary test, It was found that the Y Axis was the worst. It was taken as the representative condition for testing and its data are recorded in the present document.

**1.2 Requirement for Compliance**

(1) Field strength of Fundametal

According to 15.225(a), the field strength of any emissions within the band 13.553 - 13.567 MHz shall not exceed 15,848 microvolts/meter at 30 meters.

(2) Band Edge

According to 15.225(b), Within the bands 13.410-13.553 MHz and 13.567-13.710 MHz, the field strength of any emissions shall not exceed 334 microvolts/meter at 30 meters.

According to 15.225(c), Within the bands 13.110-13.410 MHz and 13.710-14.010 MHz the field strength of any emissions shall not exceed 106 microvolts/meter at 30 meters.

(3) Radiation emission

According to 15.225(d), the field strength of any emissions appearing outside of the 13.110-14.010 MHz band shall not exceed the general radiated emission limits in § 15.209.

(4) Frequency tolerance

According to 15.225(e), The frequency tolerance of the carrier signal shall be maintained within +/- 0.01% of the operating frequency over a temperature variation of -20 degrees to +50 degrees C at normal supply voltage, and for a variation in the primary supply voltage from 85% to 115% of the rated supply voltage at a temperature of 20 degrees C. For battery operated equipment, the equipment tests shall be performed using a new battery.

(5) Radiated emission limits, general requirements.

According to 15.209, except as provided elsewhere in this Subpart, the emissions from an intentional radiator shall not exceed the field strength levels specified in the following table:

<b>Frequency (MHz)</b>	<b>Field Strength (uV/m)</b>	<b>Measurement Distance (m)</b>
0.009 - 0.490	2400/F(kHz)	300
0.490 - 1.705	24000/F(kHz)	30
1.705 - 30.0	30	30
30 - 88	100 **	3
88 - 216	150 **	3
216 - 960	200 **	3
Above 960	500	3

\*\* Except as provided in paragraph (g), fundamental emissions from intentional radiators operating under this Section shall not be located in the frequency bands 54-72 MHz, 76-88 MHz, 174-216 MHz or 470-806 MHz. However, operation within these frequency bands is permitted under other sections of this Part, e.g., Sections 15.231 and 15.241.

(6) 20dB Bandwidth

According to 15.215(c), Intentional radiators operating under the alternative provisions to the general emission limits, as contained in §§ 15.217 through 15.257 and in Subpart E of this part, must be designed to ensure that the 20 dB bandwidth of the emission, or whatever bandwidth may otherwise be specified in the specific rule section under which the equipment operates.

According to 15.225, Operation within the band 13.110 – 14.010 MHz.

(7) Conduction Emission Requirement

For intentional device, according to §15.207(a) line conduction emission limit is as below table.

Frequency of Emission (MHz)	Conducted Limit (dBuV)	
	Quasi-peak	Average
0.15 – 0.5	66 to 56*	56 to 46*
0.5 - 5	56	46
5 - 30	60	50

\* Decreases with the logarithm of the frequency.

(8) Restricted Band

Frequency (MHz)	Frequency (MHz)	Frequency (MHz)	Frequency (GHz)
0.090 - 0.110	16.42 - 16.423	399.9 - 410	4.5 - 5.15
<sup>1</sup> 0.495 - 0.505	16.69475 - 16.69525	608 - 614	5.35 - 5.46
<sup>2</sup> 1735 - 2.1905	16.80425 - 16.80475	960 - 1240	7.25 - 7.75
4.125 - 4.128	25.5 - 25.67	1300 - 1427	8.025 - 8.5
4.17725 - 4.17775	37.5 - 38.25	1435 - 1626.5	9.0 - 9.2
4.20725 - 4.20775	73 - 74.6	1645.5 - 1646.5	9.3 - 9.5
6.215 - 6.218	74.8 - 75.2	1660 - 1710	10.6 - 12.7
6.26775 - 6.26825	108 - 121.94	1718.8 - 1722.2	13.25 - 13.4
6.31175 - 6.31225	123 - 138	2200 - 2300	14.47 - 14.5
8.291 - 8.294	149.9 - 150.05	2310 - 2390	15.35 - 16.2
8.362 - 8.366	156.52475 - 156.52525	2483.5 - 2500	17.7 - 21.4
8.37625 - 8.38675	156.7 - 156.9	2690 - 2900	22.01 - 23.12
8.41425 - 8.41475	162.0125 - 167.17	3260 - 3267	23.6 - 24.0
12.29 - 12.293	167.72 - 173.2	3332 - 3339	31.2 - 31.8
12.51975 - 12.52025	240 - 285	3345.8 - 3358	36.43 - 36.5
12.57675 - 12.57725	322 - 335.4	3600 - 4400	(2)
13.36 - 13.41			

<sup>1</sup> Until February 1, 1999, this restricted band shall be 0.490-0.510 MHz.

<sup>2</sup> Above 38.6

**1.3 The Support Units**

No.	Unit	Model No./ Serial No.	FCC ID	Trade Name	Power Cord	Supported by lab.
1	PDA	SoMo-650-1200	N/A	socket	N/A	

**1.4 Layout of Setup**

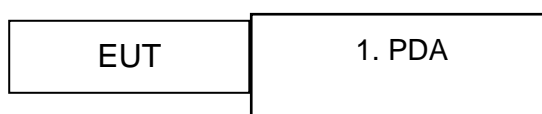

**Connecting Cables :**

No.	Cable	Length	Shielded	Core	Shielded Backshell	Supported by lab.	Note
NA	*	*	*	*	*	*	*

**1.5 Test Capability**

**Test Facility**

The test facility used for evaluating the conformance of the EUT with each standard in the present report meets what required in CISPR16-1-4, CISPR16-2-3 and ANSI C63.4.

Test Room	Type of Test Room	Descriptions
TR1	10m semi-anechoic chamber (23m×14m×9m)	Complying with the NSA requirements in documents CISPR 22 and ANSI C63.4. For the radiated emission measurement.
TR11	3m semi-anechoic chamber (9m × 6m × 6m)	
TR13	Test Site	For the RF conducted emission measurement.
TR5	Shielding Room (8m×5m×4m)	For the conducted emission measurement.

**Test Laboratory Competence Information**

Central Research Technology Co. has been accredited/registered/authorized by the agencies listed in the following table.

<b>Certificate</b>	<b>Nation</b>	<b>Agency</b>	<b>Code</b>	<b>Mark</b>
Accreditation Certificate	USA	NVLAP	200575-0	ISO/IEC 17025
	R.O.C. (Taiwan)	TAF	0905	ISO/IEC 17025
	R.O.C. (Taiwan)	BSMI	SL2-IN-E-0033, SL2-IS-E-0033, SL2-R1/R2-E-0033, SL2-A1-E-0033	ISO/IEC 17025
Site Filing Document	USA	FCC	474046, TW1053	Test facility list & NSA Data
	Canada	IC	4699A-1, -3	Test facility list & NSA Data
	Japan	VCCI	R-1527,C-1609,T-131,T-1441,G-10	Test facility list & NSA Data
Authorization Certificate	Germany	TUV	10021687-2008	ISO/IEC 17025
	Norway	Nemko	ELA212	ISO/IEC 17025

The copy of each certificate can be downloaded from our web site: [www.crc-lab.com](http://www.crc-lab.com)



## 1.6 Measurement Uncertainty

The assessed measurement uncertainty with a suitable coverage factor K to ensure 95% confidence level for the normal distribution are shown as below, the values are less than  $U_{cispr}$  in table 1 of CISPR 16-4-2.

Test Item	Measurement Uncertainty
Frequency error	4.2Hz
Radiated Emission (30MHz~200MHz)	Horizontal 2.8dB ; Vertical 3.5dB
Radiated Emission (200MHz~1GHz)	Horizontal 3.4dB ; Vertical 2.8dB

## 2 Field Strength of fundamental

Result: Pass

### 2.1 Applied Standard

According to 15.225(a), The field strength of any emissions within the band 13.553 - 13.567 MHz shall not exceed 15,848 microvolts/meter at 30 meters.

According to 15.225(b), Within the bands 13.410-13.553 MHz and 13.567-13.710 MHz, the field strength of any emissions shall not exceed 334 microvolts/meter at 30 meters.

According to 15.225(c), Within the bands 13.110-13.410 MHz and 13.710-14.010 MHz the field strength of any emissions shall not exceed 106 microvolts/meter at 30 meters.

### 2.2 Test Instruments

Test Site and Equipment	Manufacturer	Model No./ Serial No.	Last Calibration Date	Calibration Due Date
Test Receiver	R&S	ESCI/100019	2008/11/26	2009/11/25
Antenna	EMCO	6502/20558	2008/8/4	2011/8/3
Semi - anechoic Chamber	ETS. LINDGREN	TR11/ 906-A	2009/6/30	2010/6/29

Note:

1. The calibrations are traceable to NML/ROC.
2. The calibration date of the semi-anechoic chamber listed above is the date of NSA measurement.

### Instrument Setting

RBW	VBW	Detector	Trace	Comment
9kHz	N/A	Quasi-Peak	Maxhold	

### Climatic Condition

Ambient Temperature : 24°C; Relative Humidity : 55%

## 2.3 Measurement Procedure

- a. The EUT was set up per the test configuration figured in the next section of this chapter to simulate the typical usage per the user's manual.
- b. If the EUT is tabletop equipment, it was placed on a wooden table with a height of 0.8 meters above the reference ground plane in the semi-anechoic chamber. If the EUT is floor-standing equipment, it was placed on a non-conducted support with a height of 12 millimeters above the reference ground plane in the semi-anechoic chamber.
- c. The EUT was set 3m away from the interference receiving antenna.
- d. Rapidly sweep the signal in the test frequency range by using the spectrum through the Maximum-peak detector.
- e. Rotate the EUT from 0° to 360° and position the receiving loop antenna at 1~4 meters above the reference ground plane to determine the fundamental frequency and record them.
- f. Finely turn the turntable and the antenna is be positioned with its plane vertical at the specified distance from the EUT and rotated about its vertical axis for maximum response and recorded position of fundamental frequency found from step e.
- g. Record and compare the maximum level with the required limit.
- h. Change the receiving antenna to another polarization to measure Field Strength of fundamental by following step e. to g. again.

## 2.4 Test Configuration

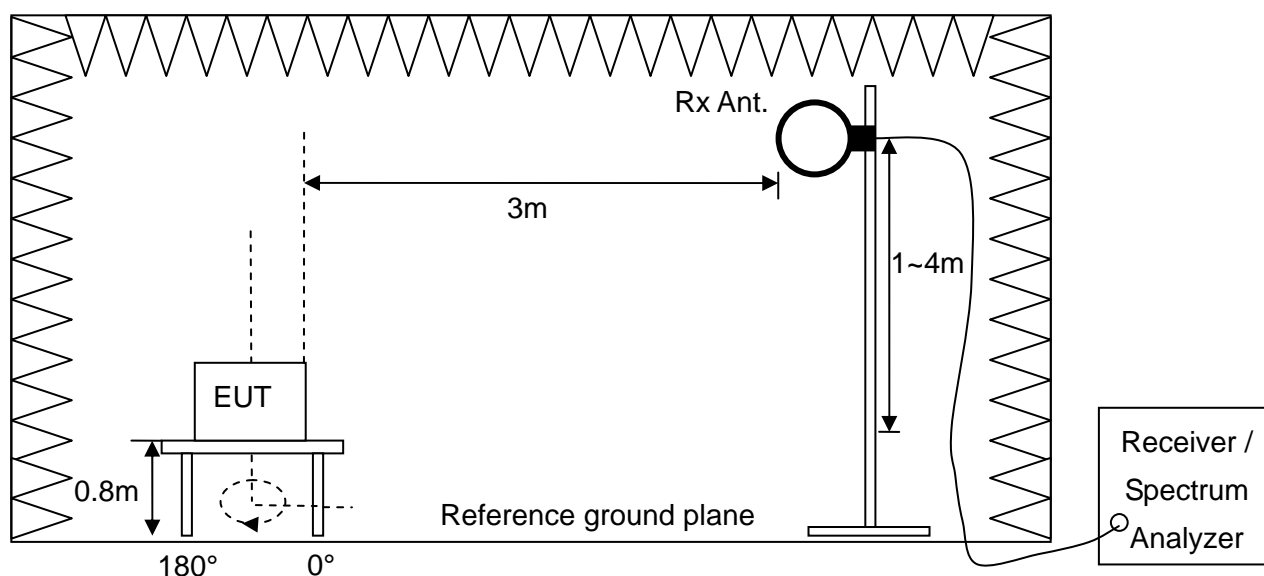

**2.5 Test Data**

**Field strength of fundamental**

**Test Mode : Continuous Transmitting**

**Test Distance : 3m Tester : Jacky**

<b>Freq. (MHz)</b>	<b>Polarization</b>	<b>Reading Data (dBuV)</b>	<b>Correction Factor (dB/m)</b>	<b>Emission Level (dBuV/m)</b>	<b>Limit (dBuV/m)</b>	<b>Margin (dB)</b>
13.56	V	58.10	13.97	72.07	124	51.93
13.56	H	59.05	13.97	73.02	124	50.98

Note :

1. Correction Factor (dB/m) = Cable Loss + Antenna Factor
2. Emission Level (dBuV/m) = Reading Data + Correction Factor
3. The limit is 15848 (uV/m)=84dBuV/m @ 30 m , The formula transfers the limit at 30 m to 3m is  $L_3 = L_{30} \times (d_{30} / d_3)^2 = L_{30}(dBuV/m) + 40 = 124 \text{ dBuV/m}$
4. Margin (dB) = Limit –Emission Level

V Polarization

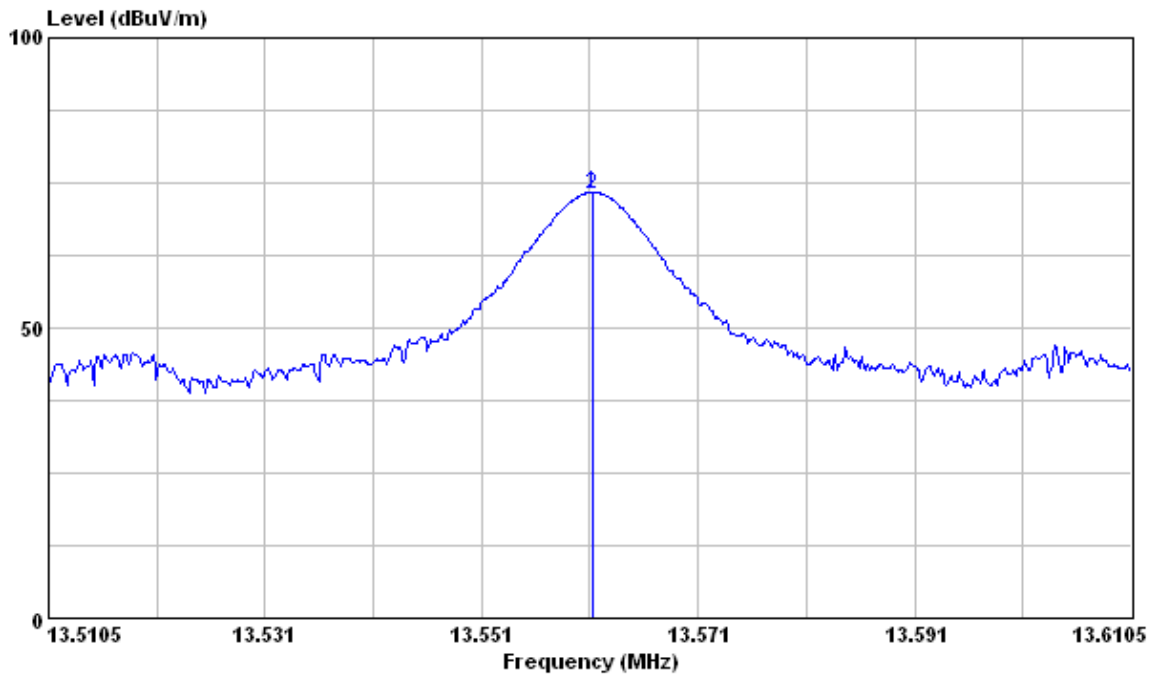

H Polarization

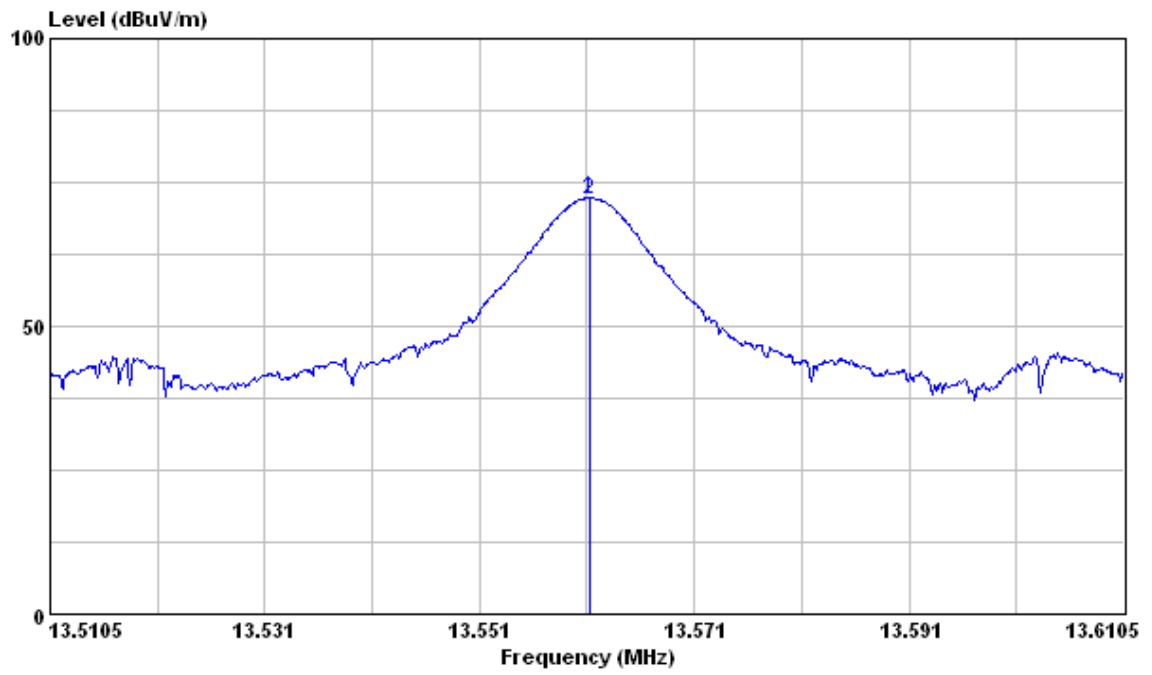

**Band Edge**

**Test Mode : Continuous Transmitting**

**Test Distance : 3m Tester : Jacky**

Emission Freq. (MHz)	Polarizortal	Reading Data (dBUV)	Correction Factor (dB/m)	Maximum Emission within the band (dBUV/m)	Limit (dBUV/m)	Margin (dB)
13.35	V	26.14	13.98	40.12	80.51	40.39
13.35	H	26.11	13.98	40.09	80.51	40.42
13.49	V	37.52	13.97	51.49	90.47	38.98
13.49	H	37.46	13.97	51.43	90.47	39.04
13.64	V	38.23	13.96	52.19	90.47	38.28
13.64	H	38.12	13.96	52.08	90.47	38.39
13.78	V	27.97	13.97	41.94	80.51	38.57
13.78	H	28.03	13.97	42.00	80.51	38.51

Note :

1. Correction Factor (dB/m) = Cable Loss + Antenna Factor
2. Maximum Emission within the band (dBUV/m) = Reading Data + Correction Factor
3. The formula transfers the limit at 30 m to 3m is  $L_3 = L_{30} \times (d_{30} / d_3)^2 = L_{30}(\text{dBUV/m}) + 40$
4. Margin (dB) = Limit -Maximum Emission within the band

V Polarization

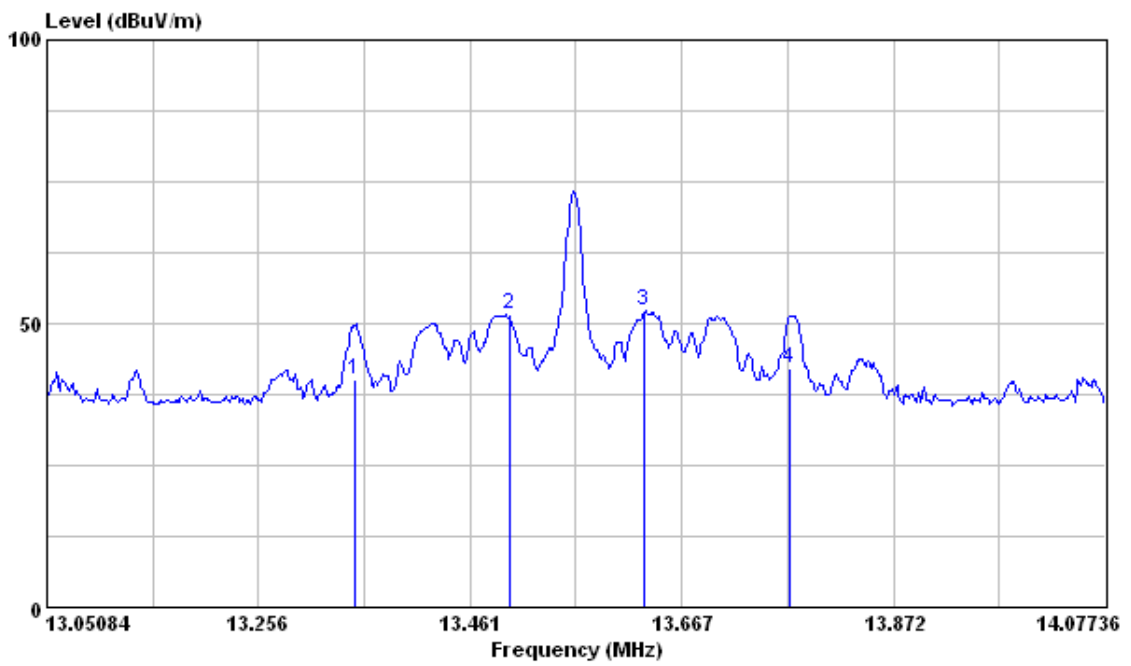

H Polarization

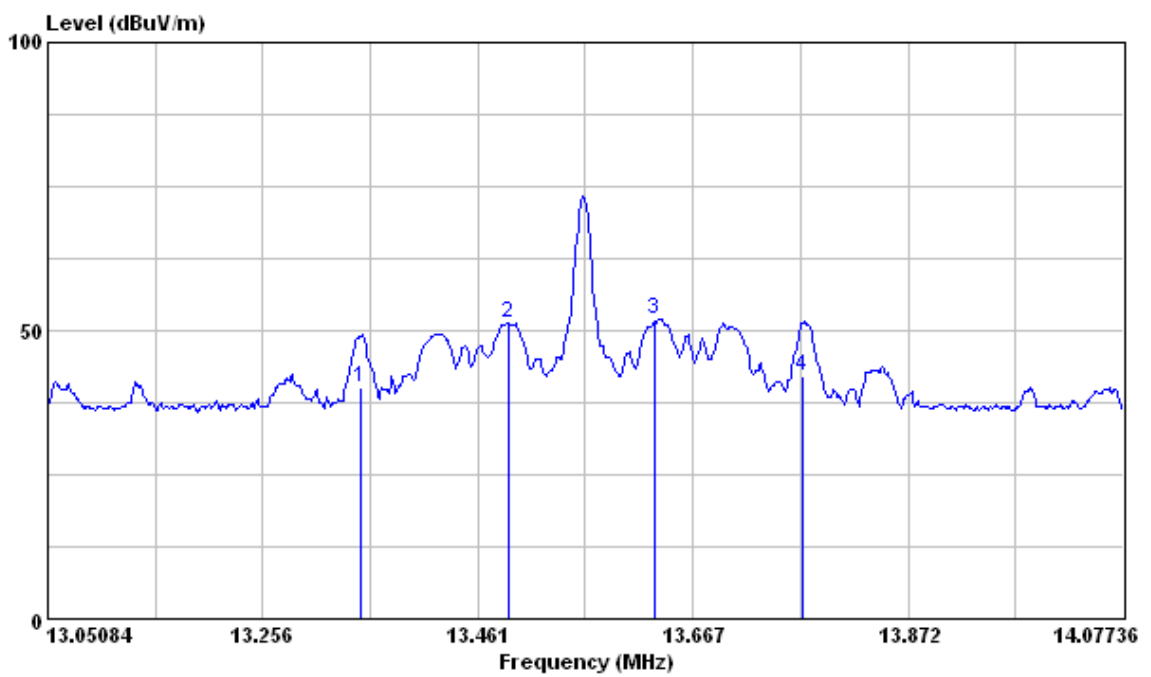

**3 Radiated Emission**

**Result: Pass**

**3.1 Applied Standard**

According to 15.225(d), The field strength of any emissions appearing outside of the 13.110-14.010 MHz band shall not exceed the general radiated emission limits in § 15.209.

<b>Frequency (MHz)</b>	<b>Field Strength (uV/m)</b>	<b>Measurement Distance (m)</b>
0.009 - 0.490	2400/F(kHz)	300
0.490 - 1.705	24000/F(kHz)	30
1.705 - 30.0	30	30
30 - 88	100 **	3
88 - 216	150 **	3
216 - 960	200 **	3
Above 960	500	3

\*\* Except as provided in paragraph (g), fundamental emissions from intentional radiators operating under this Section shall not be located in the frequency bands 54-72 MHz, 76-88 MHz, 174-216 MHz or 470-806 MHz. However, operation within these frequency bands is permitted under other sections of this Part, e.g., Sections 15.231 and 15.241.



**3.2 Test Instruments**

<b>Test Site and Equipment</b>	<b>Manufacturer</b>	<b>Model No./ Serial No.</b>	<b>Last Calibration Date</b>	<b>Calibration Due Date</b>
Semi - anechoic Chamber	ETS. LINDGREN	TR11/ 906-A	2009/6/30	2010/6/29
Spectrum Analyzer	Agilent	E4407B/ MY45106795	2009/3/19	2010/3/18
Antenna	EMCO	6502/20558	2008/8/4	2011/8/3
Broadband Antenna	EMCO	3142C/ 52088	2009/7/22	2010/7/21

Note:

1. The calibrations are traceable to NML/ROC.

**Instrument Setting**

<b>RBW</b>	<b>VBW</b>	<b>Detector</b>	<b>Trace</b>	<b>Comment</b>
9kHz	N/A	Quasi-Peak	Maxhold	Below 30MHz
120kHz	N/A	Quasi-Peak	Maxhold	Below 1GHz

**Climatic Condition**

Ambient Temperature : 24°C; Relative Humidity : 55%

### 3.3 Measurement Procedure

- a. The EUT was set up per the test configuration figured in the next section of this chapter to simulate the typical usage per the user's manual.
- b. A software provided by client enabled the EUT to transmit and receive data at specified channel frequencies individually.
- c. If the EUT is tabletop equipment, it was placed on a wooden table with a height of 0.8 meters above the reference ground plane in the semi-anechoic chamber. If the EUT is floor-standing equipment, it was placed on a non-conducted support with a height of 12 millimeters above the reference ground plane in the semi-anechoic chamber.
- d. The EUT was set 3m away from the interference receiving antenna.
- e. Rapidly sweep the signal in the test frequency range by using the spectrum through the Maximum-peak detector.
- f. Rotate the EUT from 0° to 360° and position the receiving antenna at heights from 1 to 4 meters above the reference ground plane continuously to determine at least six frequencies associated with higher emission levels and record them.
- g. Then measure each frequency found from step f. by using the spectrum with rotating the EUT and positioning the receiving antenna height to determine the maximum level.
- h. For measurement of frequency above 1000MHz, the beamwidth of receiving horn antenna should keep covering EUT when the receiving horn antenna height varied.
- i. For measurement of frequency above 1000MHz, set the spectrum analyzer to find out the maximum Peak or Average level occurred, if any.
- j. Record frequency, azimuth angle of the turntable, height, and polarization of the receiving antenna and compare the maximum level with the required limit.
- k. Change the receiving antenna to another polarization to measure radiated emission by following step e. to j. again.
- l. If the peak emission level below 1000MHz measured from step f. is 4dB lower than the limit specified, then the emission values presented will be the peak value only. Otherwise, accurate Q.P. value will be measured and presented.
- m. If the peak emission level above 1000MHz measured from step f. is 20dB lower than the limit specified, then the emission values presented will be the peak value only. Otherwise, accurate A.V. value will be measured and presented.

### 3.4 Test Configuration

#### Below 30MHz

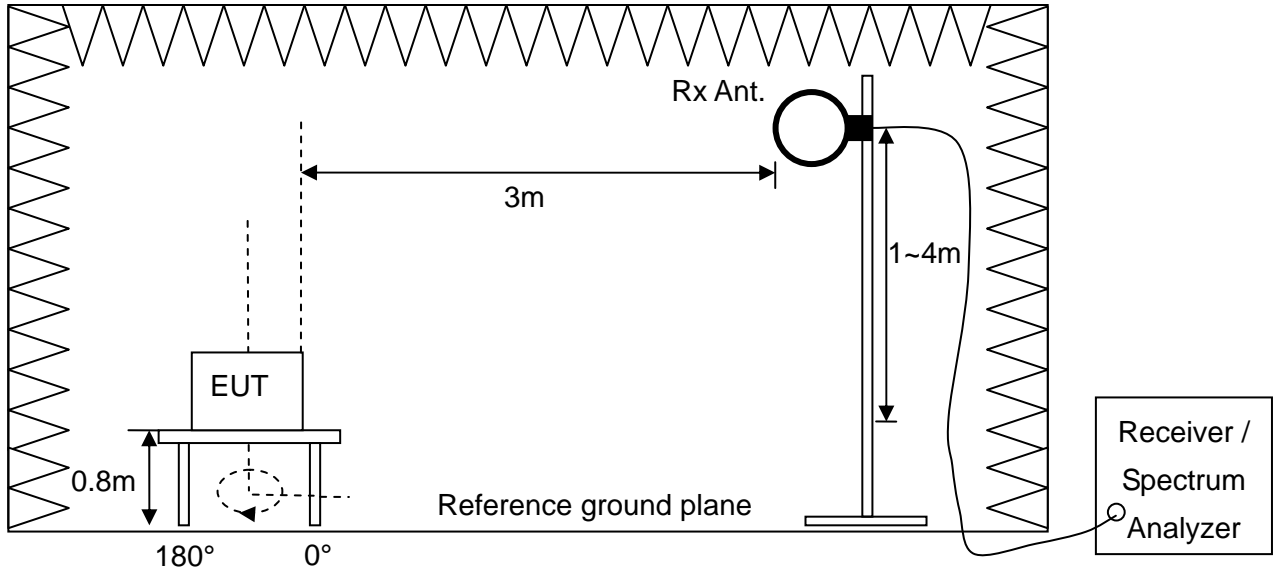

#### Above 30MHz

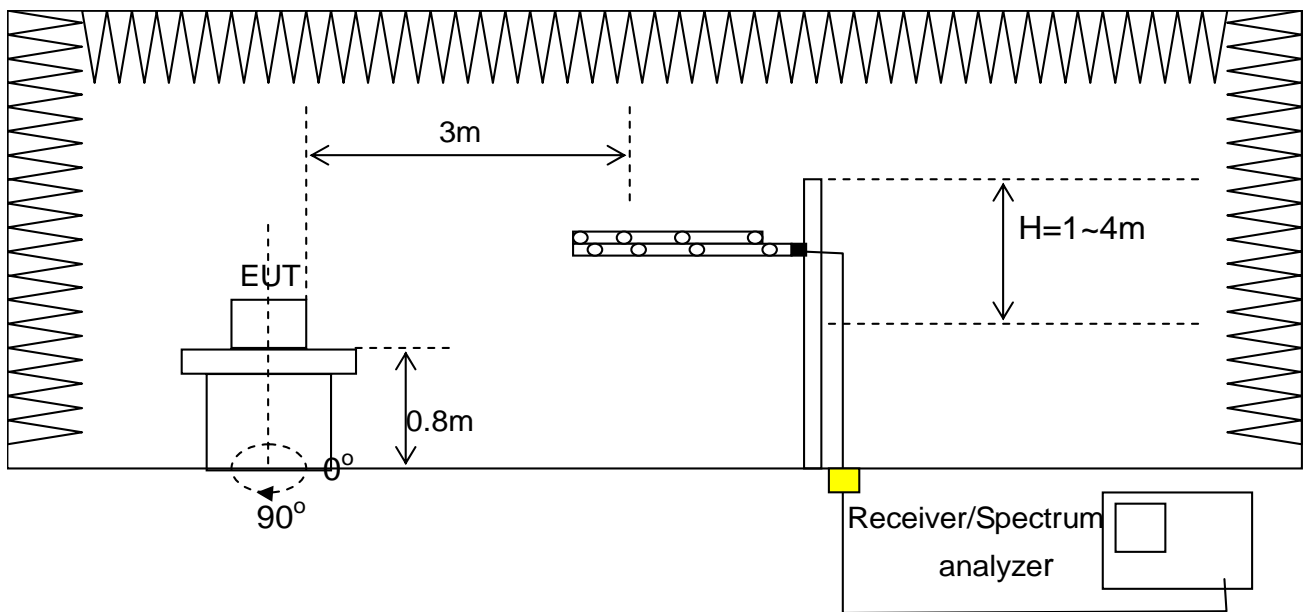

■ : Pre-amplifier

3.5 Test Data

Test Mode : Contuious transmitting  
 Test Distance :3m Tester : Jacky  
 Polarization :Vertical Frequency Range :9KHz~1GHz

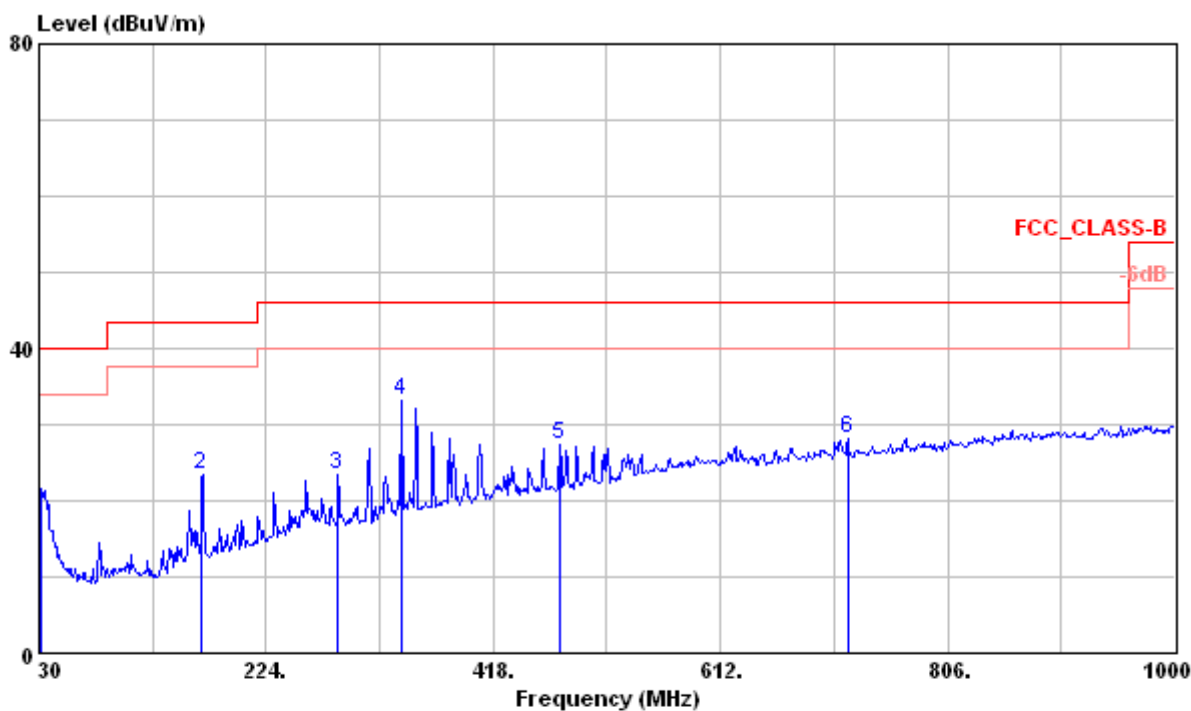

	Freq	Level	Read Level	Factor	Limit Line	Over Limit	Ant Pos	Table Pos	Pol/Phase	Remark
	MHz	dBuV/m	dBuV	dB/m	dBuV/m	dB	cm	deg		
1	31.080	21.57	31.09	-9.52	40.00	-18.43	---	---	VERTICAL	Peak
2	169.320	23.39	40.35	-16.96	43.50	-20.11	---	---	VERTICAL	Peak
3	284.880	23.43	36.37	-12.94	46.00	-22.57	---	---	VERTICAL	Peak
4	339.900	33.09	43.80	-10.71	46.00	-12.91	100	0	VERTICAL	QP
5	475.000	27.38	34.87	-7.49	46.00	-18.62	---	---	VERTICAL	Peak
6	720.700	28.09	30.92	-2.83	46.00	-17.91	---	---	VERTICAL	Peak

Note:

1. Correction Factor (dB/m) = Cable Loss + Antenna Factor
2. Emission Level (dBuV/m) = Reading Data + Correction Factor
3. Margin (dB) = Limit – Emission Level

No signal can be detected from 9kHz to 30MHz, so the graphs are omitted below 30MHz.

Test Mode : Contuious transmitting  
 Test Distance :3m Tester : Jacky  
 Polarization : Horizontal Frequency Range : 9kHz~1GHz

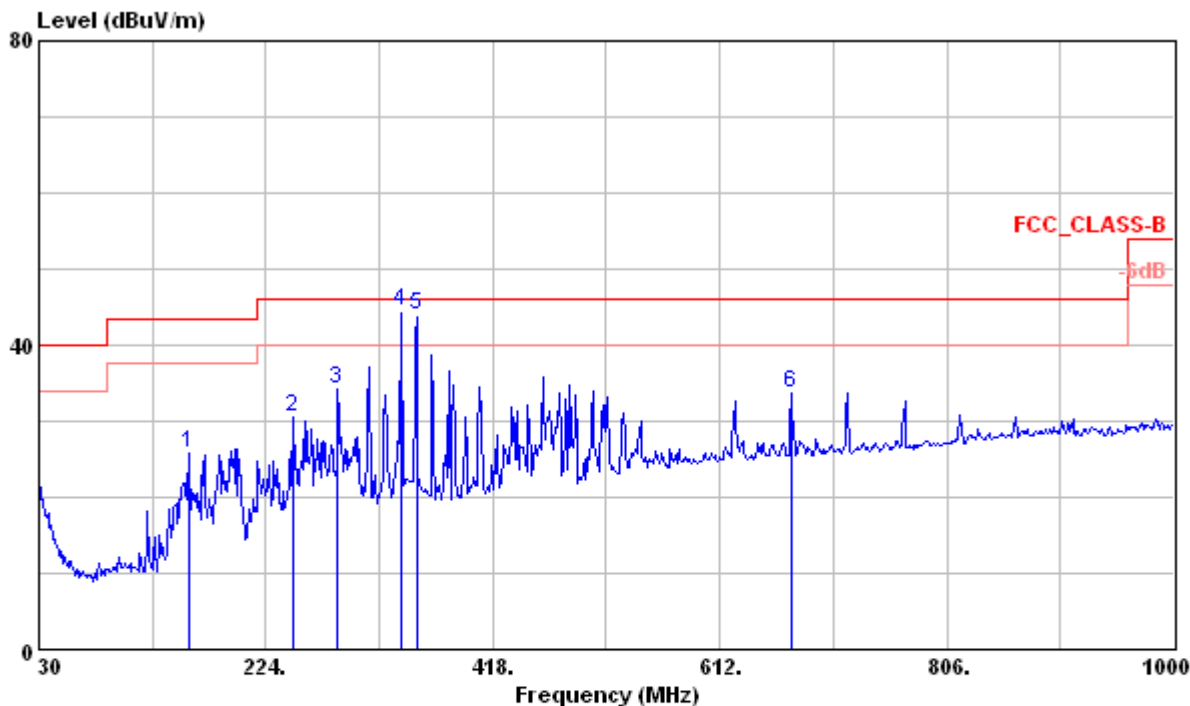

	Freq	Level	Read Level	Limit Factor	Over Limit	Ant Pos	Table Pos	Pol/Phase	Remark
	MHz	dBuV/m	dBuV	dB/m	dBuV/m	dB	cm	deg	
1	157.710	25.81	43.18	-17.37	43.50	-17.69	---	---	HORIZONTAL Peak
2	247.080	30.64	44.62	-13.98	46.00	-15.36	---	---	HORIZONTAL Peak
3	284.880	34.26	47.20	-12.94	46.00	-11.74	---	---	HORIZONTAL Peak
4	338.985	44.35	55.10	-10.75	46.00	-1.65	100	0	HORIZONTAL QP
5	352.563	43.96	54.27	-10.31	46.00	-2.04	100	360	HORIZONTAL QP
6	673.100	33.79	37.47	-3.68	46.00	-12.21	---	---	HORIZONTAL Peak

Note:

1. Correction Factor (dB/m) = Cable Loss + Antenna Factor
2. Emission Level (dBuV/m) = Reading Data + Correction Factor
3. Margin (dB) = Limit – Emission Level

No signal can be detected from 9kHz to 30MHz, so the graphs are omitted below 30MHz.

**4 Frequency Tolerance**

**Result: Pass**

**4.1 Applied Standard**

According to 15.225(e), the frequency tolerance of the carrier signal shall be maintained within +/- 0.01% of the operating frequency over a temperature variation of -20 degrees to +50 degrees C at normal supply voltage, and for a variation in the primary supply voltage from 85% to 115% of the rated supply voltage at a temperature of 20 degrees C. For battery operated equipment, the equipment tests shall be performed using a new battery.

**4.2 Test Instruments**

<b>Test Site and Equipment</b>	<b>Manufacturer</b>	<b>Model No./ Serial No.</b>	<b>Last Calibration Date</b>	<b>Calibration Due Data</b>
Spectrum Analyzer	Agilent	E4405B/ MY45106706	2009/3/25	2010/3/24
Temperature Chamber	Terchy	MHG-800LF/ 920224	2009/8/17	2010/8/16
Adjustable AC Power Supply	EXTECH	6110/1102108	NCR	NCR
Test Site	N.A.	TR13	NCR	NCR

Note:

1. The calibrations are traceable to NML/ROC.
2. NCR : No Calibration Required.

**Instrument Setting**

<b>RBW</b>	<b>VBW</b>	<b>Detector</b>	<b>Trace</b>	<b>Comment</b>
300Hz	1kHz	Peak	Maxhold	

**Climatic Condition**

Ambient Temperature : 23°C; Relative Humidity : 65%

### 4.3 Measurement Procedure

- a. The EUT was set up per the test configuration figured in the next section of this chapter and to simulate the typical usage described in the user's manual supported by the manufacturer in test site TR13.
- b. Measure the frequency tolerance by using the spectrum analyzer and following the test conditions described in FCC 15.225(e) to perform the normal and extreme test conditions tests.
- c. Record the level and compare with the required limit.

### 4.4 Test Configuration

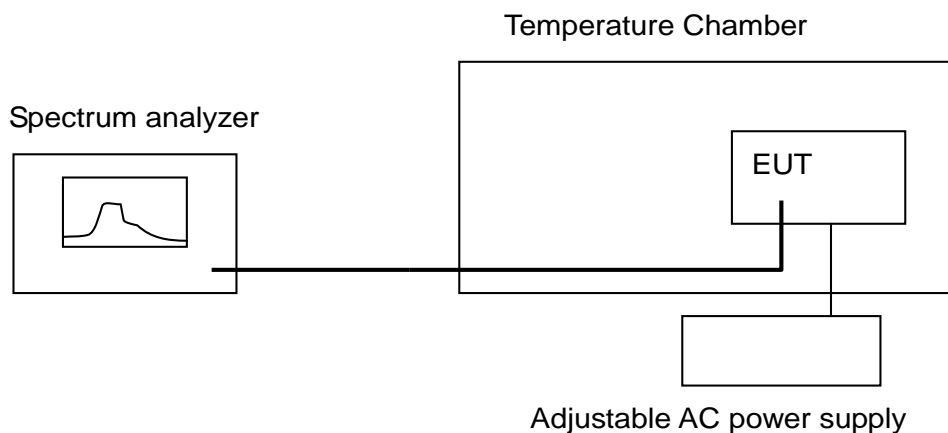

4.5 Test Data

Test Mode : Continuous transmitting

Tester : Jun Kong

Temperature (°C)	Meas. Frequency (MHz)	Deviation (MHz)	Limit (MHz)	Margin (kHz)
20°C	13.560425	NA	NA	NA
-20°C	13.560512	0.00009	0.001356	0.00127
50°C	13.560400	0.00003	0.001356	0.00133

Note:

1. Deviation(kHz) = | Meas. Frequency – Meas. Frequency @20°C |
2. Margin (kHz)= Limit – Deviation

20°C

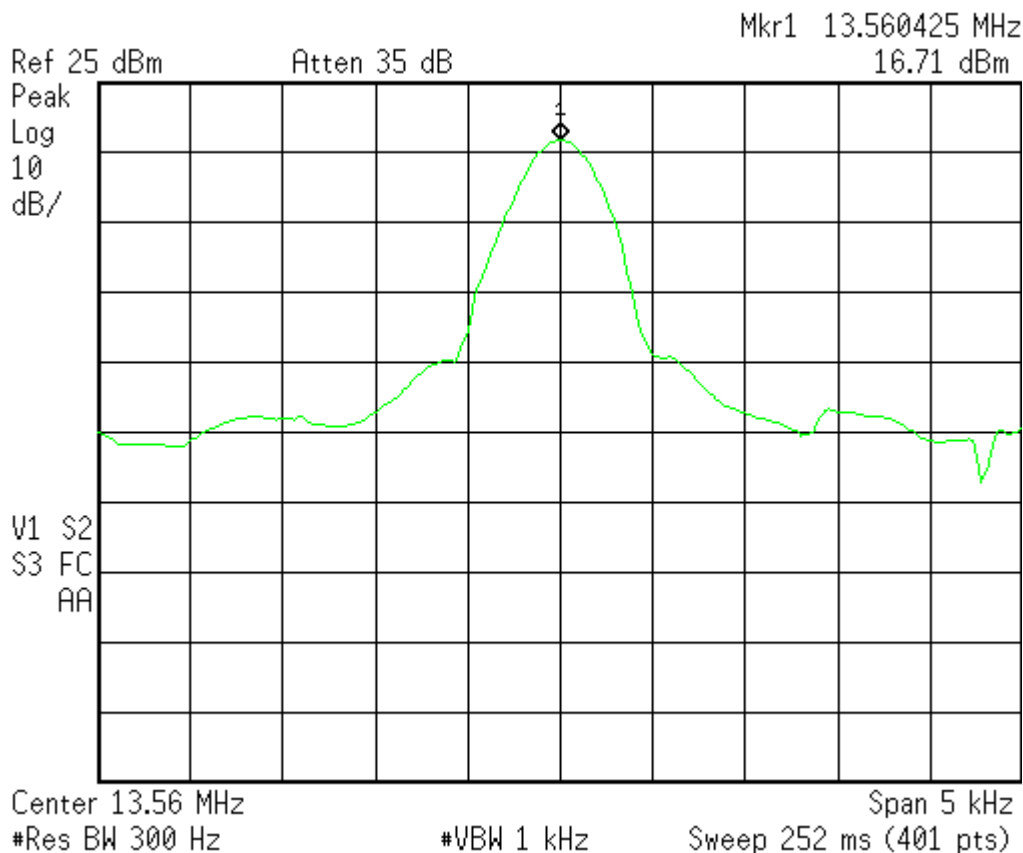



-20°C

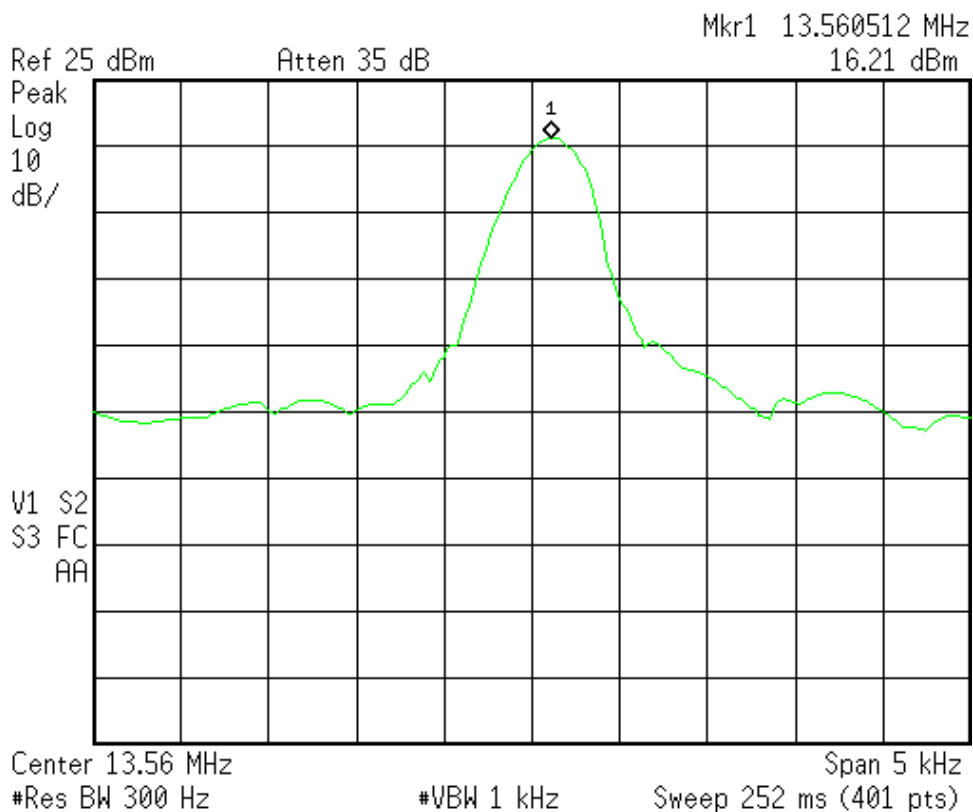

50°C

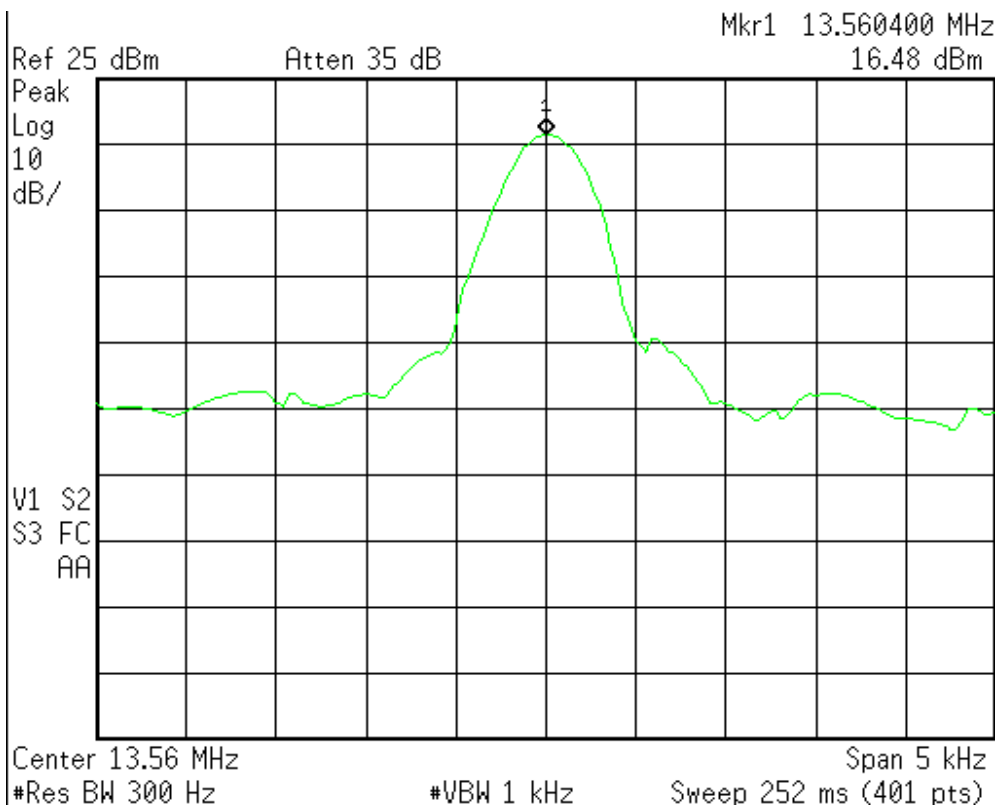

## 5 20dB Bandwidth

Result: Pass

### 5.1 Applied Standard

According to 15.215(c), Intentional radiators operating under the alternative provisions to the general emission limits, as contained in §§ 15.217 through 15.257 and in Subpart E of this part, must be designed to ensure that the 20 dB bandwidth of the emission, or whatever bandwidth may otherwise be specified in the specific rule section under which the equipment operates.

According to 15.225, Operation within the band 13.110 – 14.010 MHz.

### 5.2 Test Instruments

Test Site and Equipment	Manufacturer	Model No./ Serial No.	Last Calibration Date	Calibration Due Data
Spectrum Analyzer	Agilent	E4405B/ MY45106706	2009/3/25	2010/3/24
Test Site	N.A.	TR13	NCR	NCR

Note:

1. The calibrations are traceable to NML/ROC.
2. NCR : No Calibration Required.

### Instrument Setting

RBW	VBW	Detector	Trace	Comment
300Hz	1kHz	Peak	Maxhold	

### Climatic Condition

Ambient Temperature : 23°C; Relative Humidity : 65%

### 5.3 Measurement Procedure

- a. The EUT was set up per the test configuration figured in the next section of this chapter and to simulate the typical usage described in the user's manual supported by the manufacturer in chamber TR13.
- b. Measure the 20dB bandwidth by using the spectrum analyzer and following the test conditions described in FCC 15.215.
- c. Record the frequencies and compare with the required limit.

### 5.4 Test Configuration



5.5 Test Data

Test Mode : Continuous transmitting  
 Tester : Jun Kong

Operating Frequency (MHz)	The lowest frequency (MHz)	The highest frequency (MHz)	Limit (MHz)
13.56	13.559987	13.560800	13.110~14.01

