

# **FCC Test Report**

for

## **Contactless Card Reader**

**Trade Name : Uniform**  
**Model Number : UIC681**  
**FCC ID : TFJ681**  
**Report Number : RF-U010-0902-164**  
**Date of Report : March 9, 2009**

Prepared for

### **Uniform Industrial Corp.**

1st. FL,NO.1,Lane 15,Chih Chiang St., Tu Cheng City, Taipei Hsien, Taiwan,R.O.C.

Prepared by



### **Central Research Technology Co.**

#### **EMC Test Laboratory**

No.11, Lane41, Fushuen St., Jungshan Chiu, Taipei, Taiwan, 104, R.O.C.



NVLAP LAB CODE 200575-0

**This report shall not be reproduced, except in full, without the written approval of Central Research Technology Co.. It may be duplicated completely in its entirety for legal use with the permission of the applicant. It should not be used to claim product endorsement by NVLAP or any U.S. government agency. The test result in the report applies only to the sample tested.**

# Certification

**Equipment under Test** : Contactless Card Reader  
**Model No.** : UIC681  
**FCC ID** : TFJ681  
**Manufacturer** : Uniform Industrial Corp.  
**Applicant** : Uniform Industrial Corp.  
**Address** : 1st. FL,NO.1,Lane 15,Chih Chiang St., Tu Cheng City, Taipei Hsien, Taiwan,R.O.C.  
**Date of Receipt** : February 19, 2009  
**Date of Testing** : February 20~27, 2009  
**Applicable Standards** : 47 CFR part 15, Subpart C  
**Deviation** : N/A  
**Condition of Test Sample** : Enigneering Sample

We, **Central Research Technology Co.**, hereby certify that one sample of the designated product was tested in our facility during the period mentioned above. The test records, data evaluation and Equipment Under Test (EUT) configurations shown in the present report are true and accurate representation of the measurements of the sample's RF characteristics under the conditions herein specified.

The test results show that the EUT as described in the present report is in compliance with the requirements set forth in the standards mentioned above and apply to the tested sample identified in the present report only. The test report shall not be reproduced, except in its entirety, without the written approval of Central Research Technology Co.

**PREPARED BY** : Rosa Hsieh , **DATE** : March 9, 2009  
(Rosa Hsieh/System Executive)

**APPROVED BY** : J. Y. Shih , **DATE** : Mar. 9, 2009  
(Tsun-Yu Shih/General Manager)

## Contents

<b>1</b>	<b>General Description .....</b>	<b>5</b>
1.1	GENERAL DESCRIPTION OF EUT .....	5
1.2	TEST METHODOLOGY .....	6
1.3	REQUIREMENT FOR COMPLIANCE.....	7
1.4	THE SUPPORT UNITS .....	9
1.5	LAYOUT OF SETUP .....	9
1.6	TEST CAPABILITY .....	10
<b>2</b>	<b>Field Strength of fundamental.....</b>	<b>12</b>
2.1	APPLIED STANDARD .....	12
2.2	TEST INSTRUMENTS .....	12
2.3	MEASUREMENT PROCEDURE.....	13
2.4	TEST CONFIGURATION .....	13
2.5	TEST DATA .....	14
<b>3</b>	<b>Radiated Emission .....</b>	<b>20</b>
3.1	APPLIED STANDARD .....	20
3.2	TEST INSTRUMENTS .....	21
3.3	MEASUREMENT PROCEDURE.....	22
3.4	TEST CONFIGURATION .....	23
3.5	TEST DATA .....	24
<b>4</b>	<b>Frequency Tolarence .....</b>	<b>32</b>
4.1	APPLIED STANDARD .....	32
4.2	TEST INSTRUMENTS .....	32
4.3	MEASUREMENT PROCEDURE.....	33
4.4	TEST CONFIGURATION .....	33
4.5	TEST DATA .....	34
<b>5</b>	<b>20dB Bandwidth .....</b>	<b>37</b>
5.1	APPLIED STANDARD .....	37
5.2	TEST INSTRUMENTS .....	37
5.3	MEASUREMENT PROCEDURE.....	38
5.4	TEST CONFIGURATION .....	38
5.5	TEST DATA .....	39
<b>6</b>	<b>Conducted Emission Measurement .....</b>	<b>40</b>
6.1	LIMITS FOR EMISSION MEASUREMENT .....	40

---

<b>6.2</b>	<b>TEST INSTRUMENTS .....</b>	<b>41</b>
<b>6.3</b>	<b>TEST PROCEDURES .....</b>	<b>42</b>
<b>6.4</b>	<b>TEST CONFIGURATIONS .....</b>	<b>43</b>
<b>6.5</b>	<b>TEST RESULTS .....</b>	<b>44</b>

**Attachment 1 – Photographs of the Test Configurations**

**Attachment 2 – External Photographs of EUT**

**Attachment 3 – Internal Photographs of EUT**

**Attachment 4 – Modifications of EUT**

## 1 General Description

### 1.1 General Description of EUT

Equipment under Test: Contactless Card Reader

Model No. : UIC681

Model Different : Please refer to the P/N# Description in next page

Power in : Power supplied by connected notebook or power adapter

Test Voltage : 120Vac/ 60Hz to connected notebook or power adapter

Power Adaptor #1 :

Brand Name : Powertron Electronics Corps.

Model Name : PA1008-1Du

Input : 100-240Vac, 50/60Hz, 0.3A

Output : 5Vdc, 1.0A

Power Adaptor #2 :

Model Name : M6-7US05R-A

Input : 100-240Vac, 50/60Hz, 0.3A

Output : 5Vdc, 1.44A

Power Adaptor #3 :

Brand Name : Weames Global Co. LTD

Model Name : JOD-S-050100A

Input : 110-240Vac, 50/60Hz, 0.2A

Output : 5Vdc, 1.0A

Manufacturer : Uniform Industrial Corp.

Channel Numbers : 1

Frequency Range : 13.56MHz

Function Modulation : FSK

Function Description :

The EUT is used to transmit and receive signal and data both. Please refer to the user's manual for the details.

**P/N# Description**

The Contactless Card Reader series P/N# Description defined by manufacturer is listed below:

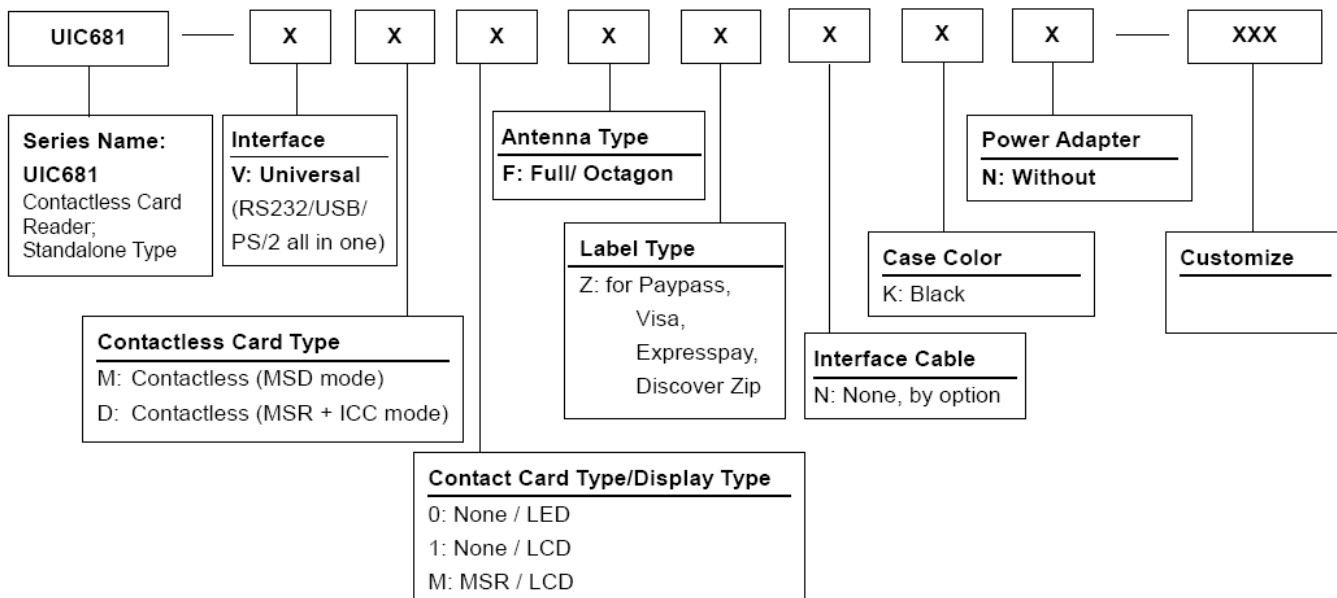

**1.2 Test Methodology**

For this E.U.T., the radiated emissions measurement performed according to the procedures illustrated in ANSI C63.4:2003 and other required were illustrated in separate sections of this test report for detail.

**Test Mode:**

	<b>Mode Description</b>	<b>Test Item</b>
<b>Mode 1</b>	Connected to the USB port of notebook; Powered by power adaptor connected to notebook	15.225(a) ~ (d) 15.209
<b>Mode 2</b>	Connected to Series port of notebook; Powered by power adaptor connected to series cable <sup>[note]</sup>	15.207, 15.209, 15.215(c), 15.225(a) ~ (e)

Note:According to the preliminary test, it was found that the power adaptor #3 is the worst case. It is taken as the representative condition for the testing and its data are recorded in the present document.

**1.3 Requirement for Compliance**

(1) Field strength of Fundametal

According to 15.225(a), the field strength of any emissions within the band 13.553 - 13.567 MHz shall not exceed 15,848 microvolts/meter at 30 meters.

(2) Band Edge

According to 15.225(b), Within the bands 13.410-13.553 MHz and 13.567-13.710 MHz, the field strength of any emissions shall not exceed 334 microvolts/meter at 30 meters.

According to 15.225(c), Within the bands 13.110-13.410 MHz and 13.710-14.010 MHz the field strength of any emissions shall not exceed 106 microvolts/meter at 30 meters.

(3) Radiation emission

According to 15.225(d), the field strength of any emissions appearing outside of the 13.110-14.010 MHz band shall not exceed the general radiated emission limits in § 15.209.

(4) Frequency tolerance

According to 15.225(e), The frequency tolerance of the carrier signal shall be maintained within +/- 0.01% of the operating frequency over a temperature variation of -20 degrees to +50 degrees C at normal supply voltage, and for a variation in the primary supply voltage from 85% to 115% of the rated supply voltage at a temperature of 20 degrees C. For battery operated equipment, the equipment tests shall be performed using a new battery.

(5) Radiated emission limits, general requirements.

According to 15.209, except as provided elsewhere in this Subpart, the emissions from an intentional radiator shall not exceed the field strength levels specified in the following table:

<b>Frequency (MHz)</b>	<b>Field Strength (uV/m)</b>	<b>Measurement Distance (m)</b>
0.009 - 0.490	2400/F(kHz)	300
0.490 - 1.705	24000/F(kHz)	30
1.705 - 30.0	30	30
30 - 88	100 **	3
88 - 216	150 **	3
216 - 960	200 **	3
Above 960	500	3

\*\* Except as provided in paragraph (g), fundamental emissions from intentional radiators operating under this Section shall not be located in the frequency bands 54-72 MHz, 76-88 MHz, 174-216 MHz or 470-806 MHz. However, operation within these frequency bands is permitted under other sections of this Part, e.g., Sections 15.231 and 15.241.

(6) 20dB Bandwidth

According to 15.215(c) requires the device must be designed to ensure that the 20 dB bandwidth of the emission, or whatever bandwidth may otherwise be specified in the specific rule section under which the equipment operates.

According to 15.225, Operation within the band 13.110 – 14.010 MHz.

(7) Conduction Emission Requirement

For intentional device, according to §15.207(a) line conduction emission limit is as below table.

Frequency of Emission (MHz)	Conducted Limit (dBuV)	
	Quasi-peak	Average
0.15 – 0.5	66 to 56*	56 to 46*
0.5 - 5	56	46
5 - 30	60	50

\* Decreases with the logarithm of the frequency.

(8) Restricted Band

Frequency (MHz)	Frequency (MHz)	Frequency (MHz)	Frequency (GHz)
0.090 - 0.110	16.42 - 16.423	399.9 - 410	4.5 - 5.15
<sup>1</sup> 0.495 - 0.505	16.69475 - 16.69525	608 - 614	5.35 - 5.46
<sup>2</sup> 1735 - 2.1905	16.80425 - 16.80475	960 - 1240	7.25 - 7.75
4.125 - 4.128	25.5 - 25.67	1300 - 1427	8.025 - 8.5
4.17725 - 4.17775	37.5 - 38.25	1435 - 1626.5	9.0 - 9.2
4.20725 - 4.20775	73 - 74.6	1645.5 - 1646.5	9.3 - 9.5
6.215 - 6.218	74.8 - 75.2	1660 - 1710	10.6 - 12.7
6.26775 - 6.26825	108 - 121.94	1718.8 - 1722.2	13.25 - 13.4
6.31175 - 6.31225	123 - 138	2200 - 2300	14.47 - 14.5
8.291 - 8.294	149.9 - 150.05	2310 - 2390	15.35 - 16.2
8.362 - 8.366	156.52475 - 156.52525	2483.5 - 2500	17.7 - 21.4
8.37625 - 8.38675	156.7 - 156.9	2690 - 2900	22.01 - 23.12
8.41425 - 8.41475	162.0125 - 167.17	3260 - 3267	23.6 - 24.0
12.29 - 12.293	167.72 - 173.2	3332 - 3339	31.2 - 31.8
12.51975 - 12.52025	240 - 285	3345.8 - 3358	36.43 - 36.5
12.57675 - 12.57725	322 - 335.4	3600 - 4400	(2)
13.36 - 13.41			

<sup>1</sup> Until February 1, 1999, this restricted band shall be 0.490-0.510 MHz.

<sup>2</sup> Above 38.6



1.4 The Support Units

No.	Unit	Model No./ Serial No.	FCC ID	Trade Name	Power Cord	Supported by lab.
1	Notebook	LATITUDE D400/5FL891S	DoC	DELL	0.8m	✓

1.5 Layout of Setup

Mode 1

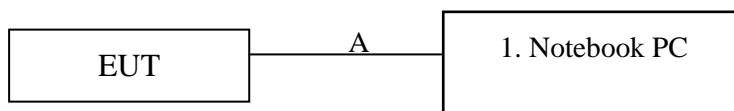

Connecting Cables :

No.	Cable	Length	Shielded	Core	Shielded Backshell	Supported by lab.	Note
A	USB Cable	2.0m	✓				

Mode 2

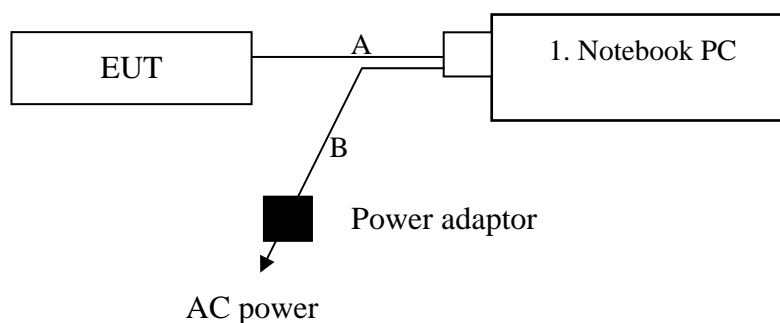

Connecting Cables :

No.	Cable	Length	Shielded	Core	Shielded Backshell	Supported by lab.	Note
A	RS-232 Cable	2.0m	✓				
B	DC Power Cord	1.8m					

**Justification:**

For both conducted and radiated emission below 1GHz, the system was configured for typical fashion as a customer could use it normally.

For radiated emission, measurement of radiated emission from digital circuit is performed with normal transmitting.

**1.6 Test Capability**

**Test Facility**

The test facility used for evaluating the conformance of the EUT with each standard in the present report meets what required in CISPR16-1-4, CISPR16-2-3 and ANSI C63.4.

<b>Test Room</b>	<b>Type of Test Room</b>	<b>Descriptions</b>
TR1	10m semi-anechoic chamber (23m×14m×9m)	Complying with the NSA requirements in documents CISPR 22 and ANSI C63.4. For the radiated emission measurement.
TR11	3m semi-anechoic chamber (9m × 6m × 6m)	
TR13	Chamber	For the RF conducted emission measurement.
TR5	Shielding Room (8m×5m×4m)	For the conducted emission measurement.

**Test Laboratory Competence Information**

Central Research Technology Co. has been accredited/registered/authorized by the agencies listed in the following table.

<b>Certificate</b>	<b>Nation</b>	<b>Agency</b>	<b>Code</b>	<b>Mark</b>
Accreditation Certificate	USA	NVLAP	200575-0	ISO/IEC 17025
	R.O.C. (Taiwan)	TAF	0905	ISO/IEC 17025
	R.O.C. (Taiwan)	BSMI	SL2-IN-E-0033, SL2-IS-E-0033, SL2-R1/R2-E-0033, SL2-A1-E-0033	ISO/IEC 17025
Site Filing Document	USA	FCC	474046, TW1053	Test facility list & NSA Data
	Canada	IC	4699A-1, -3	Test facility list & NSA Data
	Japan	VCCI	R-1527,C-1609,T-131,T-1441	Test facility list & NSA Data
Authorization Certificate	Germany	TUV	10021687-2007	ISO/IEC 17025
	Norway	Nemko	ELA212	ISO/IEC 17025

The copy of each certificate can be downloaded from our web site: [www.crc-lab.com](http://www.crc-lab.com)

**2 Field Strength of fundamental**

**Result: Pass**

**2.1 Applied Standard**

According to 15.225(a), The field strength of any emissions within the band 13.553 - 13.567 MHz shall not exceed 15,848 microvolts/meter at 30 meters.

According to 15.225(b), Within the bands 13.410-13.553 MHz and 13.567-13.710 MHz, the field strength of any emissions shall not exceed 334 microvolts/meter at 30 meters.

According to 15.225(c), Within the bands 13.110-13.410 MHz and 13.710-14.010 MHz the field strength of any emissions shall not exceed 106 microvolts/meter at 30 meters.

**2.2 Test Instruments**

<b>Test Site and Equipment</b>	<b>Manufacturer</b>	<b>Model No./ Serial No.</b>	<b>Last Calibration Date</b>	<b>Calibration Due Date</b>
Spectrum Analyzer	Agilent	E4407B/ MY45106706	2008/3/19	2009/3/18
Antenna	EMCO	6502/20558	2008/8/4	2011/8/3
Semi - anechoic Chamber	ETS. LINDGREN	TR11/ 906-A	2008/6/30	2009/6/29

Note:

1. The calibrations are traceable to NML/ROC.
2. The calibration date of the semi-anechoic chamber listed above is the date of NSA measurement.

**Instrument Setting**

<b>RBW</b>	<b>VBW</b>	<b>Detector</b>	<b>Trace</b>	<b>Comment</b>
9kHz	N/A	Quasi-Peak	Maxhold	

**Climatic Condition**

Ambient Temperature : 24°C; Relative Humidity : 55%

## 2.3 Measurement Procedure

- a. The EUT was set up per the test configuration figured in the next section of this chapter to simulate the typical usage per the user's manual.
- b. If the EUT is tabletop equipment, it was placed on a wooden table with a height of 0.8 meters above the reference ground plane in the semi-anechoic chamber. If the EUT is floor-standing equipment, it was placed on a non-conducted support with a height of 12 millimeters above the reference ground plane in the semi-anechoic chamber.
- c. The EUT was set 3m away from the interference receiving antenna.
- d. Rapidly sweep the signal in the test frequency range by using the spectrum through the Maximum-peak detector.
- e. Rotate the EUT from 0° to 360° and position the receiving loop antenna at 1~4 meters above the reference ground plane to determine the fundamental frequency and record them.
- f. Finely turn the turntable and the antenna is be positioned with its plane vertical at the specified distance from the EUT and rotated about its vertical axis for maximum response and recorded position of fundamental frequency found from step e.
- g. Record and compare the maximum level with the required limit.
- h. Change the receiving antenna to another polarization to measure Field Strength of fundamental by following step e. to g. again.

## 2.4 Test Configuration

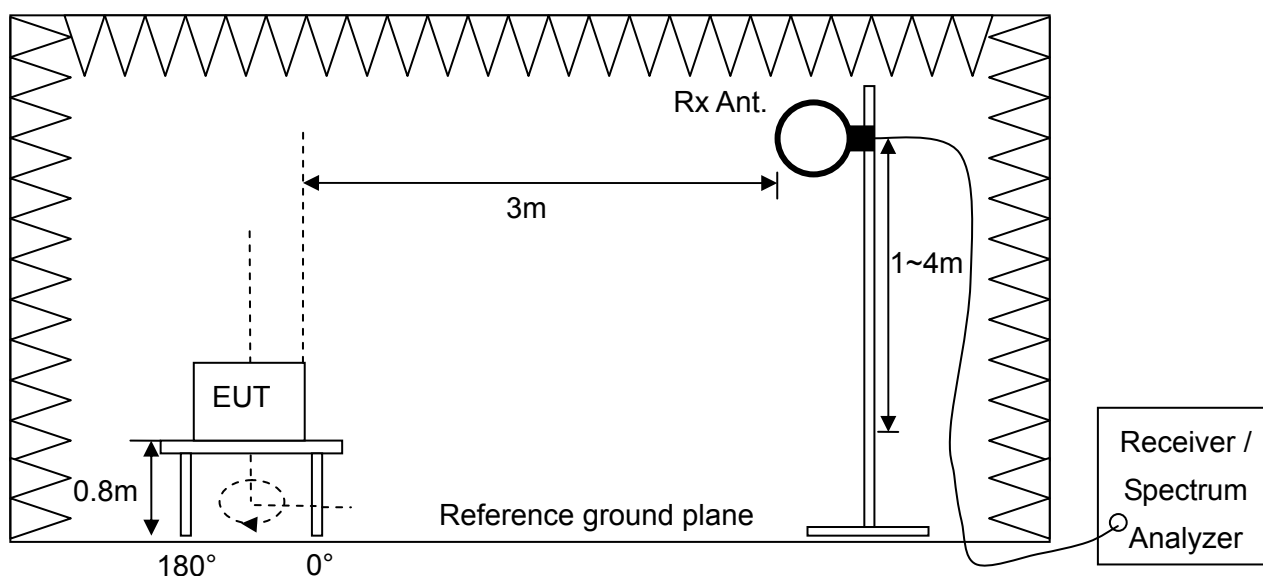

**2.5 Test Data**

**Field strength of fundamental**

**Test Mode : Mode 1**

**Test Distance : 3m Tester : Jacky**

<b>Freq. (MHz)</b>	<b>Polarization</b>	<b>Reading Data (dBuV)</b>	<b>Correction Factor (dB/m)</b>	<b>Emission Level (dBuV/m)</b>	<b>Limit (dBuV/m)</b>	<b>Margin (dB)</b>
13.56	V	57.00	13.97	70.97	124	50.03
13.56	H	52.89	13.97	66.86	124	57.14

**Test Mode : Mode 2**

**Test Distance : 3m Tester : Jacky**

<b>Freq. (MHz)</b>	<b>Polarization</b>	<b>Reading Data (dBuV)</b>	<b>Correction Factor (dB/m)</b>	<b>Emission Level (dBuV/m)</b>	<b>Limit (dBuV/m)</b>	<b>Margin (dB)</b>
13.56	V	57.79	13.97	71.76	124	52.24
13.56	H	52.27	13.97	66.24	124	57.76

Note :

1. Correction Factor (dB/m) = Cable Loss + Antenna Factor
2. Emission Level (dBuV/m) = Reading Data + Correction Factor
3. The limit is 15848 (uV/m)=84dBuV/m @ 30 m , The formula transfers the limit at 30 m to 3m is  $L_3 = L_{30} \times (d_{30} / d_3)^2 = L_{30}(dBuV/m) + 40 = 124 \text{ dBuV/m}$
4. Margin (dB) = Limit –Emission Level

Mode 1

V Polarization

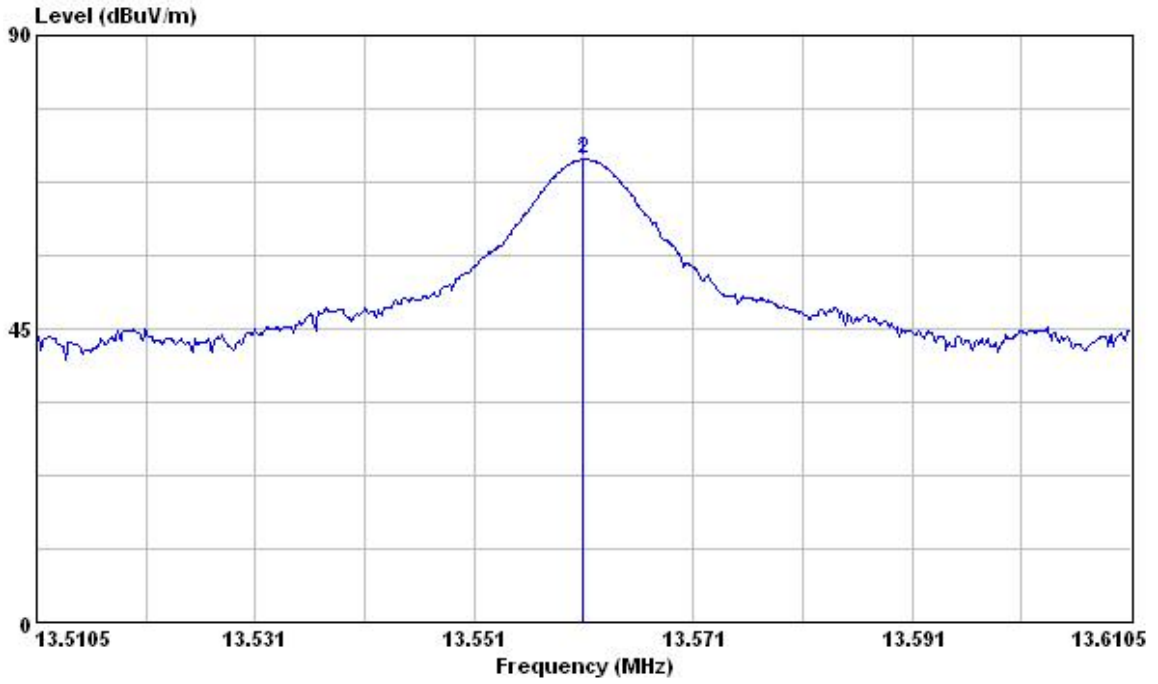

H Polarization

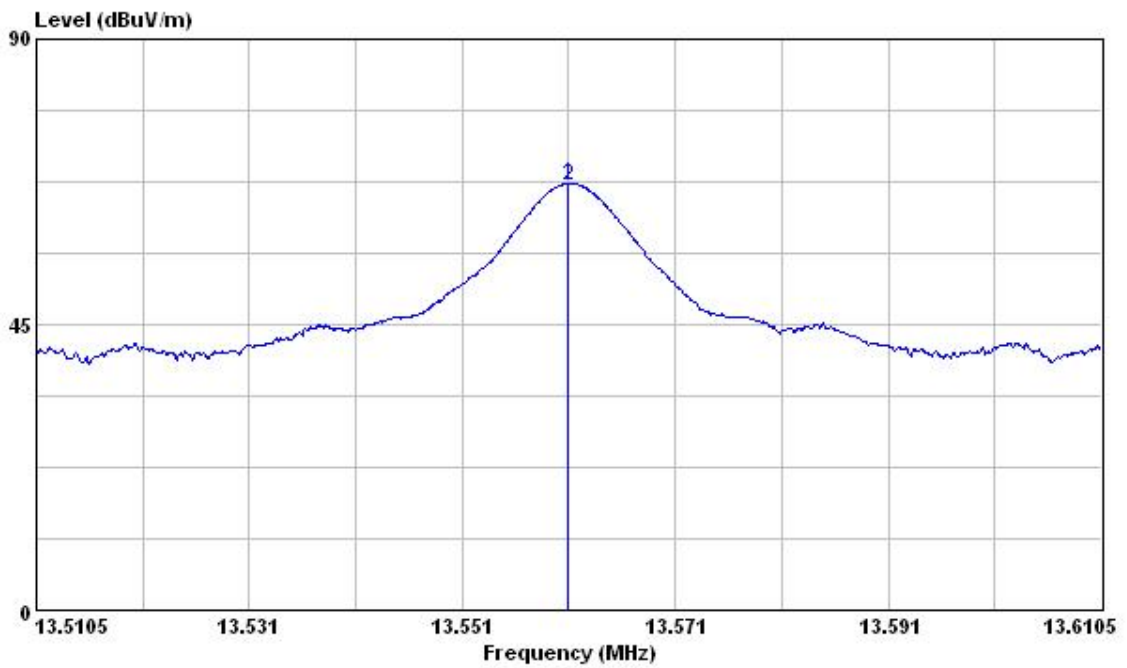

Mode 2

V Polarization

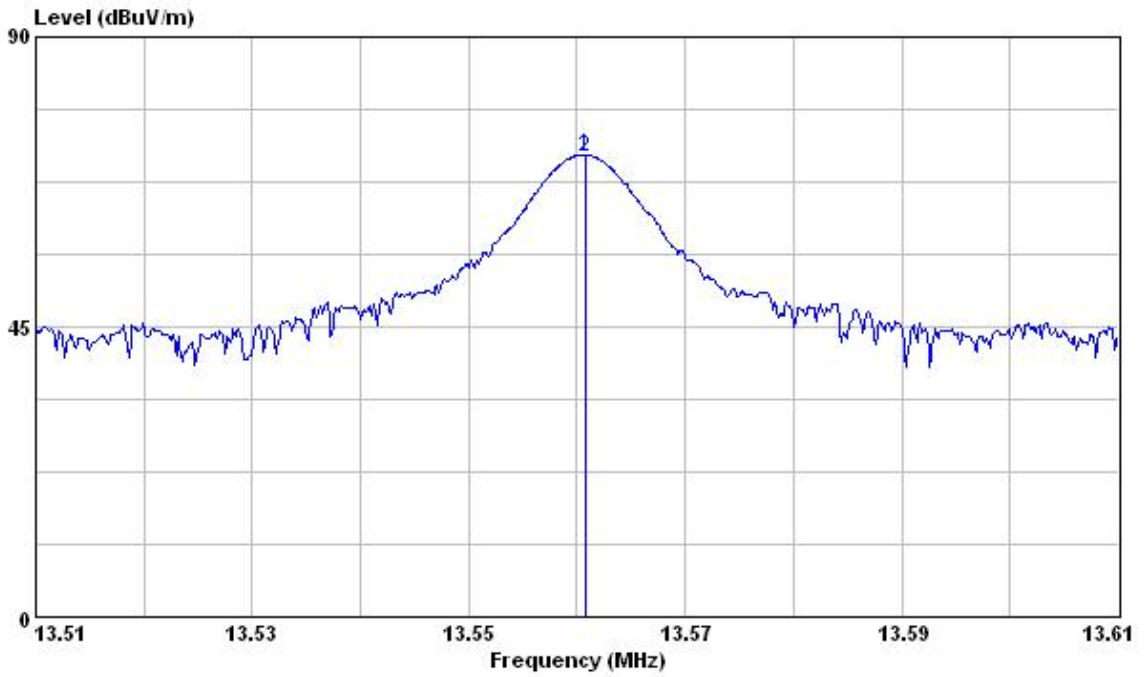

H Polarization

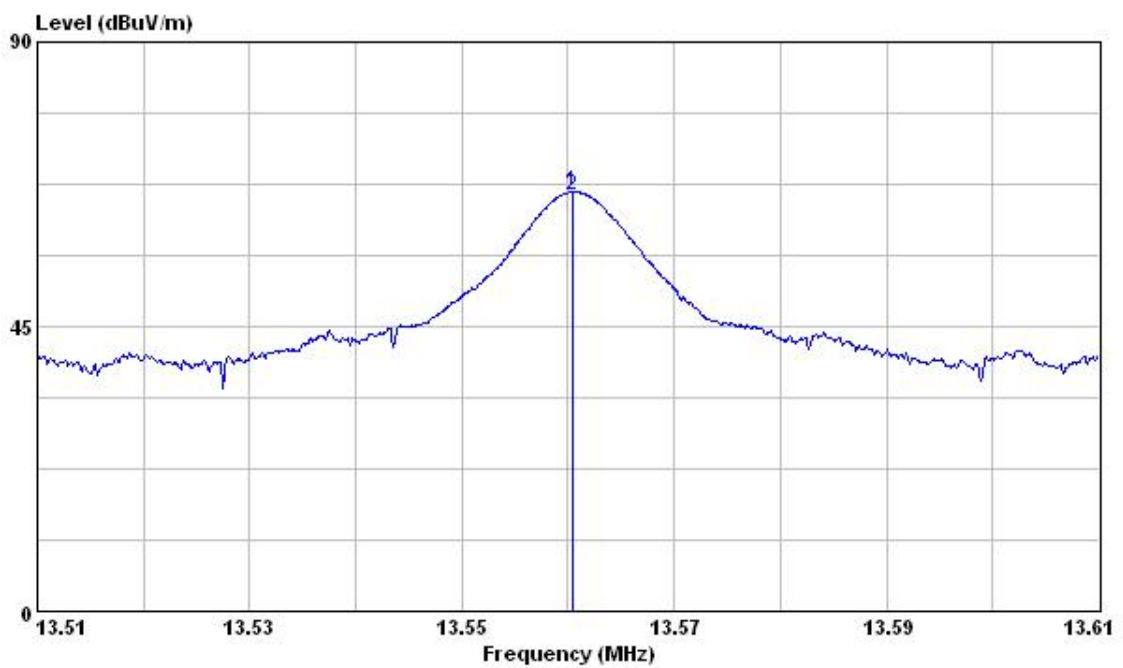



**Band Edge**

**Test Mode : Mode 1**

**Test Distance : 3m Tester : Jacky**

Emission Freq. (MHz)	Polarizortal	Reading Data (dBuV)	Correction Factor (dB/m)	Maximum Emission within the band (dBuV/m)	Limit (dBuV/m)	Margin (dB)
13.49	V	35.07	13.97	49.04	90.47	41.43
13.49	H	31.69	13.97	45.66	90.47	44.81
13.64	V	34.60	13.96	48.56	90.47	41.91
13.64	H	31.08	13.96	45.04	90.47	45.43
13.35	V	24.13	13.98	38.11	80.51	42.40
13.35	H	20.22	13.98	34.20	80.51	46.31
13.78	V	23.10	13.97	37.07	80.51	43.44
13.78	H	19.54	13.97	33.51	80.51	47.00

**Test Mode : Mode 2**

**Test Distance : 3m Tester : Jacky**

Emission Freq. (MHz)	Polarizortal	Reading Data (dBuV)	Correction Factor (dB/m)	Maximum Emission within the band (dBuV/m)	Limit (dBuV/m)	Margin (dB)
13.49	V	35.32	13.97	49.29	90.47	41.18
13.49	H	31.96	13.97	45.93	90.47	44.54
13.64	V	35.67	13.96	49.63	90.47	40.84
13.64	H	30.36	13.96	44.32	90.47	46.15
13.35	V	24.53	13.98	38.51	80.51	42.00
13.35	H	20.89	13.98	34.87	80.51	45.64
13.77	V	23.64	13.97	37.61	80.51	42.90
13.77	H	20.70	13.97	34.67	80.51	45.84

Note :

1. Correction Factor (dB/m) = Cable Loss + Antenna Factor
2. Maximum Emission within the band (dBuV/m) = Reading Data + Correction Factor
3. The formula transfers the limit at 30 m to 3m is  $L_3 = L_{30} \times (d_{30} / d_3)^2 = L_{30}(\text{dBuV/m}) + 40$
4. Margin (dB) = Limit –Maximum Emission within the band

Mode 1

V Polarization

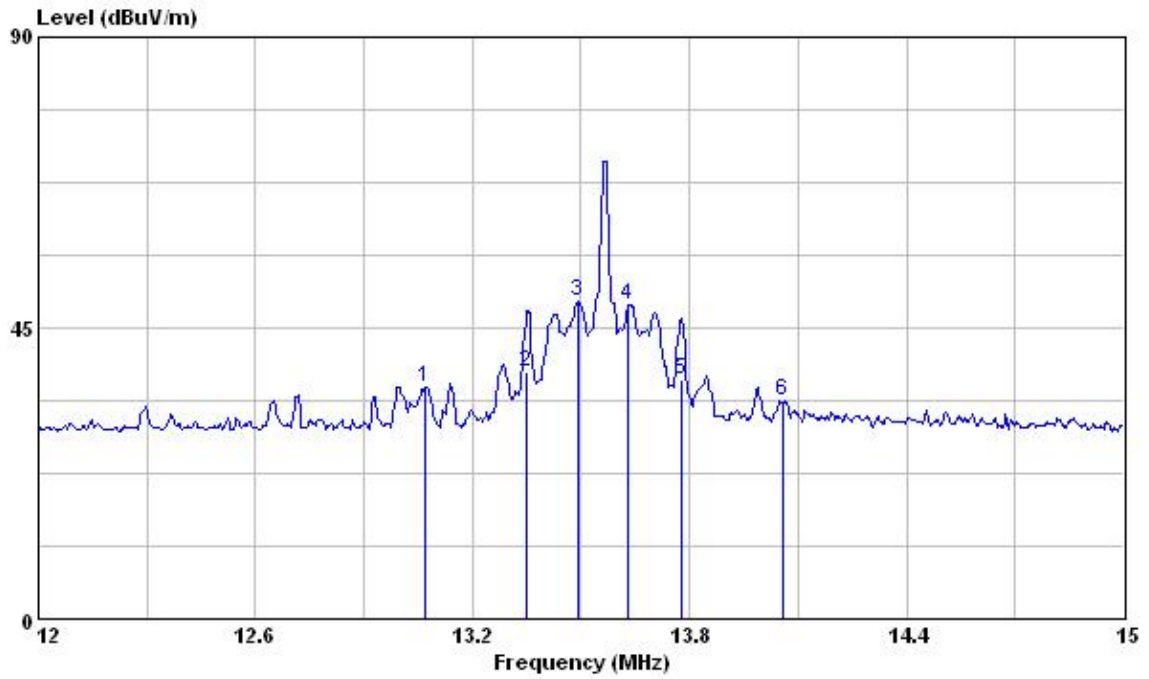

H Polarization

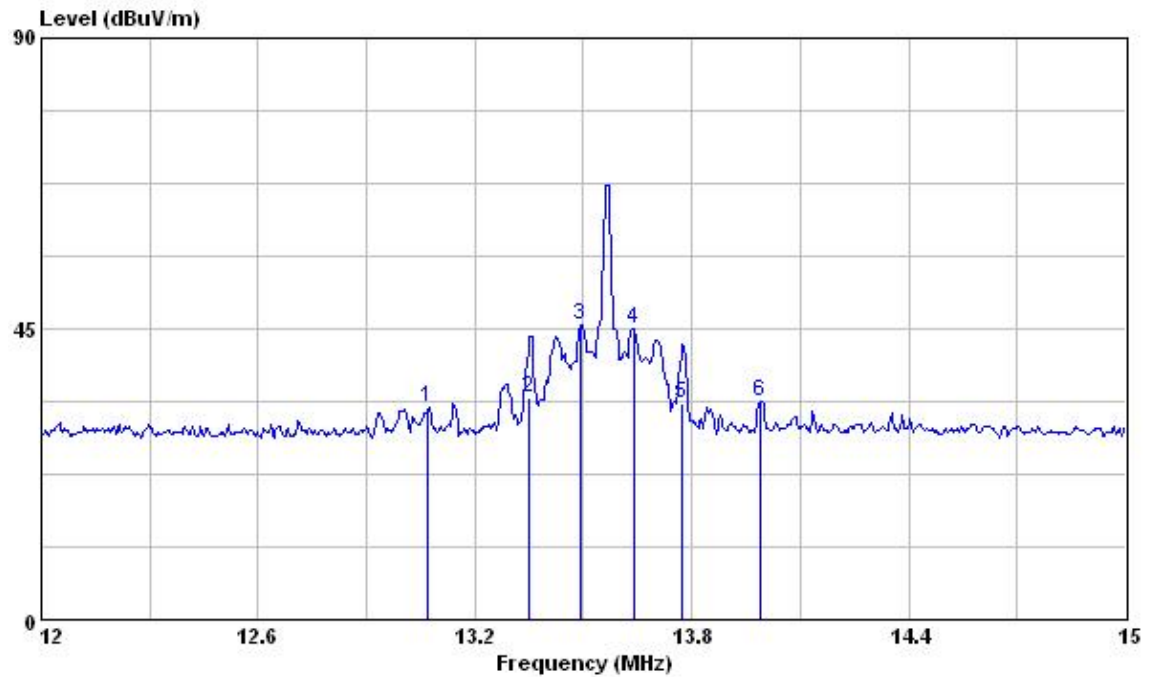

Mode 2

V Polarization

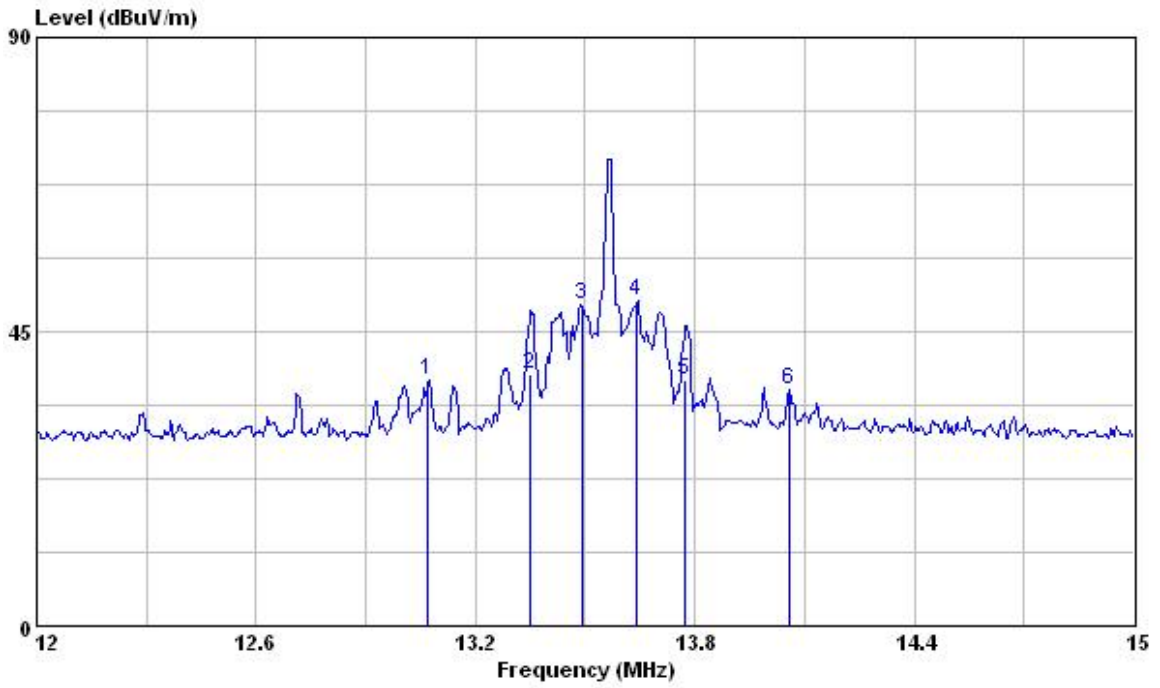

H Polarization

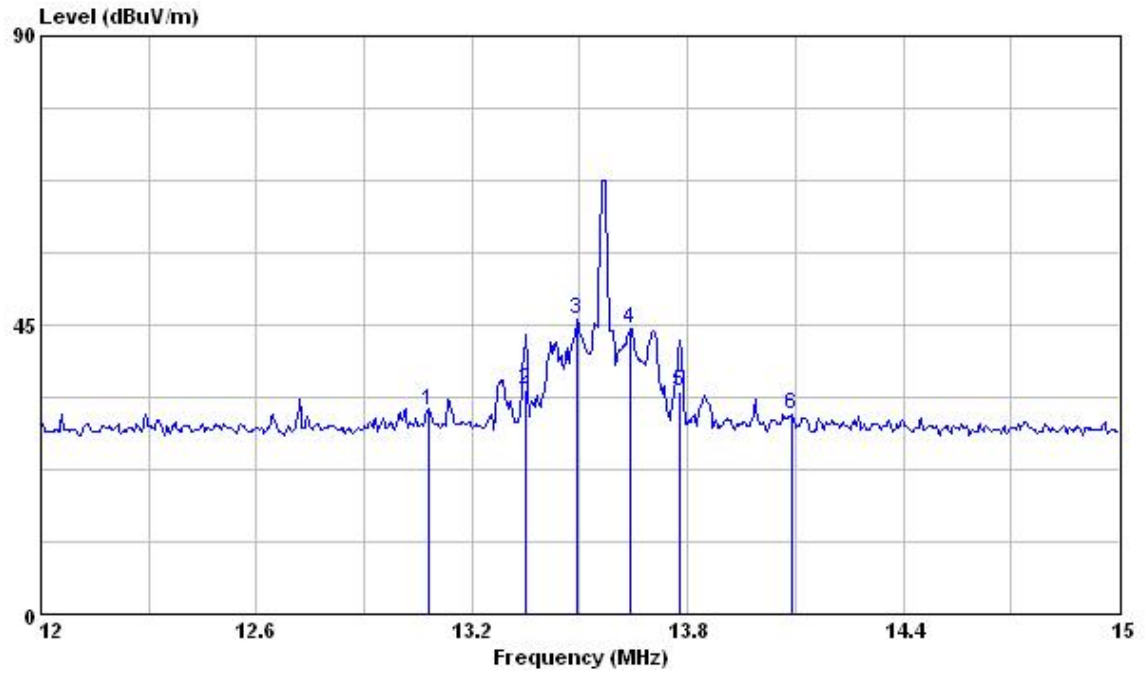

**3 Radiated Emission**

**Result: Pass**

**3.1 Applied Standard**

According to 15.225(d), The field strength of any emissions appearing outside of the 13.110-14.010 MHz band shall not exceed the general radiated emission limits in § 15.209.

<b>Frequency (MHz)</b>	<b>Field Strength (uV/m)</b>	<b>Measurement Distance (m)</b>
0.009 - 0.490	2400/F(kHz)	300
0.490 - 1.705	24000/F(kHz)	30
1.705 - 30.0	30	30
30 - 88	100 **	3
88 - 216	150 **	3
216 - 960	200 **	3
Above 960	500	3

\*\* Except as provided in paragraph (g), fundamental emissions from intentional radiators operating under this Section shall not be located in the frequency bands 54-72 MHz, 76-88 MHz, 174-216 MHz or 470-806 MHz. However, operation within these frequency bands is permitted under other sections of this Part, e.g., Sections 15.231 and 15.241.

### 3.2 Test Instruments

Test Site and Equipment	Manufacturer	Model No./ Serial No.	Last Calibration Date	Calibration Due Date
Semi - anechoic Chamber	ETS. LINDGREN	TR11/ 906-A	2008/6/30	2009/6/29
Spectrum Analyzer	Agilent	E4407B/ MY45106706	2008/3/19	2009/3/18
Antenna	EMCO	6502/20558	2008/8/4	2011/8/3
Broadband Antenna	EMCO	3142C/ 52088	2008/7/27	2009/7/26

Note:

1. The calibrations are traceable to NML/ROC.

### Instrument Setting

RBW	VBW	Detector	Trace	Comment
9kHz	N/A	Quasi-Peak	Maxhold	Below 30MHz
120kHz	N/A	Quasi-Peak	Maxhold	Below 1GHz

### Climatic Condition

Ambient Temperature : 24°C; Relative Humidity : 55%

### 3.3 Measurement Procedure

- a. The EUT was set up per the test configuration figured in the next section of this chapter to simulate the typical usage per the user's manual.
- b. A software provided by client enabled the EUT to transmit and receive data at specified channel frequencies individually.
- c. If the EUT is tabletop equipment, it was placed on a wooden table with a height of 0.8 meters above the reference ground plane in the semi-anechoic chamber. If the EUT is floor-standing equipment, it was placed on a non-conducted support with a height of 12 millimeters above the reference ground plane in the semi-anechoic chamber.
- d. The EUT was set 3m away from the interference receiving antenna.
- e. Rapidly sweep the signal in the test frequency range by using the spectrum through the Maximum-peak detector.
- f. Rotate the EUT from 0° to 360° and position the receiving antenna at heights from 1 to 4 meters above the reference ground plane continuously to determine at least six frequencies associated with higher emission levels and record them.
- g. Then measure each frequency found from step f. by using the spectrum with rotating the EUT and positioning the receiving antenna height to determine the maximum level.
- h. For measurement of frequency above 1000MHz, the beamwidth of receiving horn antenna should keep covering EUT when the receiving horn antenna height varied.
- i. For measurement of frequency above 1000MHz, set the spectrum detector to be Peak or Average to find out the maximum level occurred, if any.
- j. Record frequency, azimuth angle of the turntable, height, and polarization of the receiving antenna and compare the maximum level with the required limit.
- k. Change the receiving antenna to another polarization to measure radiated emission by following step e. to j. again.
- l. If the peak emission level below 1000MHz measured from step f. is 4dB lower than the limit specified, then the emission values presented will be the peak value only. Otherwise, accurate Q.P. value will be measured and presented.
- m. If the peak emission level above 1000MHz measured from step f. is 20dB lower than the limit specified, then the emission values presented will be the peak value only. Otherwise, accurate A.V. value will be measured and presented.

### 3.4 Test Configuration

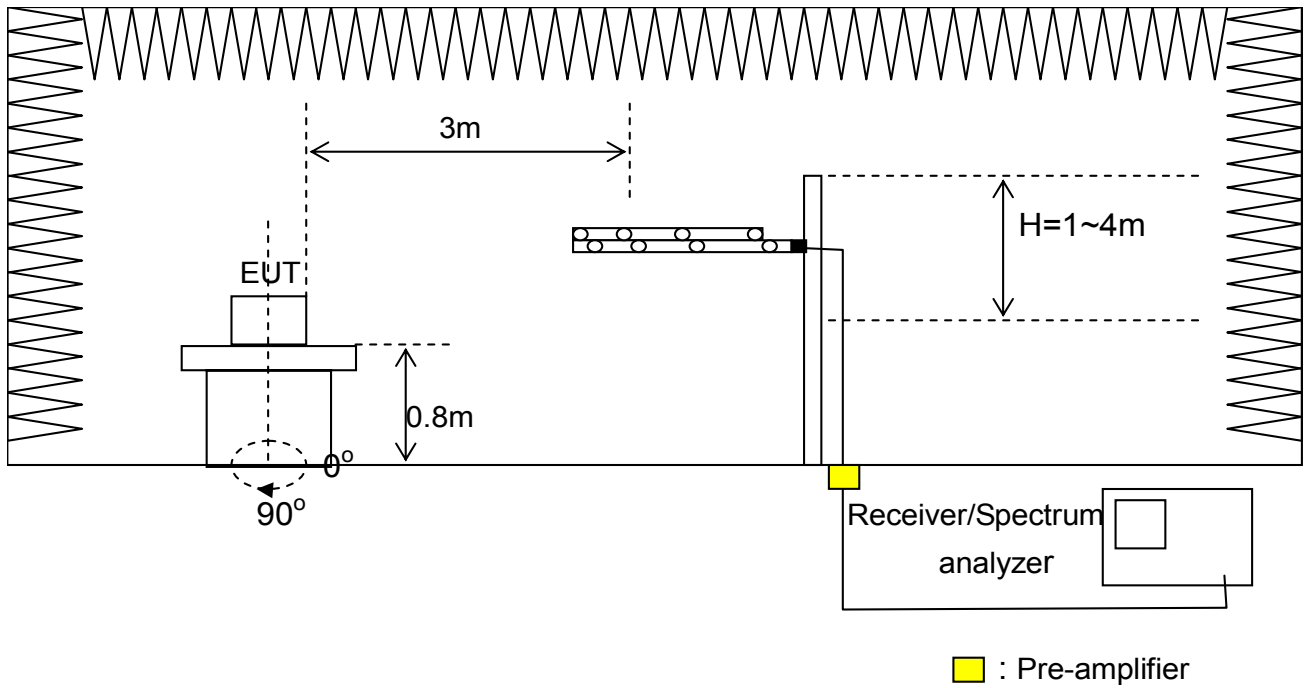

**3.5 Test Data**

**Test Mode** : Mode 1  
**Test Distance** : 3m **Tester** : Jacky  
**Polarization** : Vertical **Frequency Range** : 10MHz~30MHz

	<b>Freq. (MHz)</b>	<b>Reading Data (dBuV)</b>	<b>Correction Factor (dB/m)</b>	<b>Emission Level (dBuV/m)</b>	<b>Limit (dBuV/m)</b>	<b>Margin (dB)</b>	<b>Detector</b>
1	12.30	18.86	14.01	32.87	69.54	36.67	Peak
2	16.26	16.83	13.88	30.71	69.54	38.83	Peak
3	22.76	16.83	13.43	30.26	69.54	39.28	Peak

Note:

1. Correction Factor (dB/m) = Cable Loss + Antenna Factor
2. Emission Level (dBuV/m) = Reading Data + Correction Factor
3. Margin (dB) = Limit – Emission Level
4. The formula transfers the limit at 30 m to 3m is  $L_3 = L_{30} \times (d_{30} / d_3)^2 = L_{30}(\text{dBuV/m}) + 40$

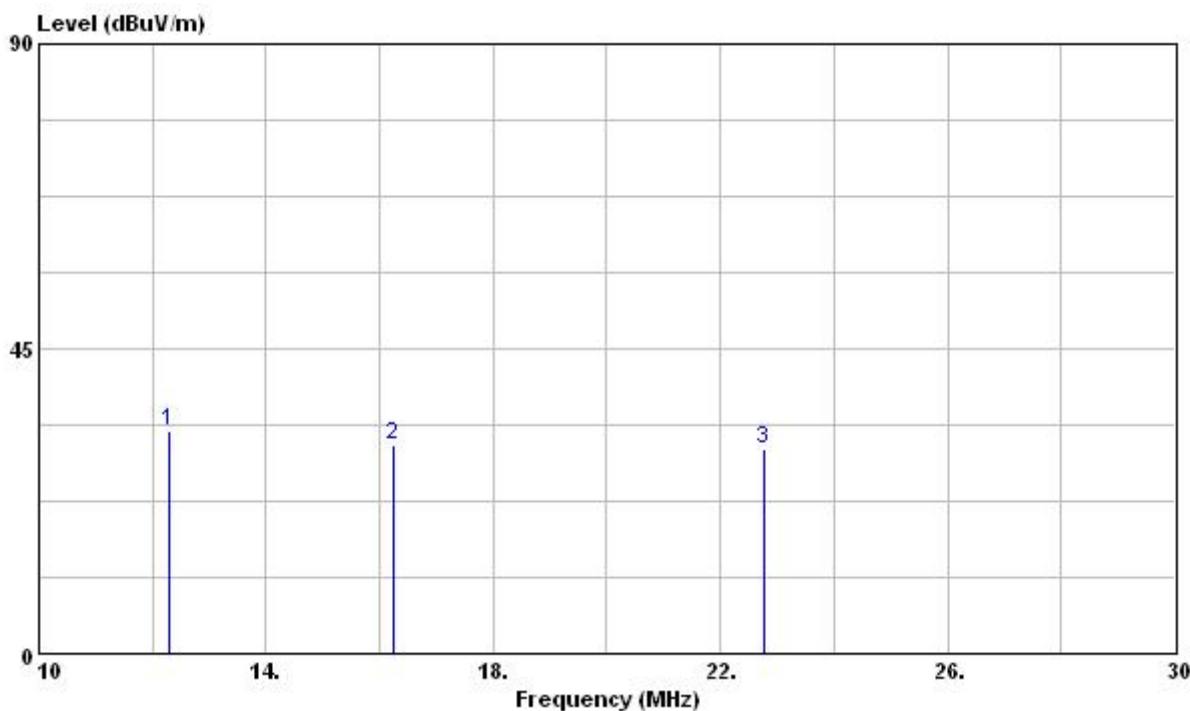



**Test Mode : Mode 1**

**Test Distance :3m**

**Tester : Jacky**

**Polarization : Horizontal**

**Frequency Range : 10MHz~30MHz**

	<b>Freq. (MHz)</b>	<b>Reading Data (dBuV)</b>	<b>Correction Factor (dB/m)</b>	<b>Emission Level (dBuV/m)</b>	<b>Limit (dBuV/m)</b>	<b>Margin (dB)</b>	<b>Detector</b>
1	11.68	17.16	14.02	31.18	69.54	38.36	Peak
2	17.20	15.82	13.84	29.66	69.54	39.88	Peak
3	20.56	17.31	13.68	30.99	69.54	38.55	Peak

Note:

1. Correction Factor (dB/m) = Cable Loss + Antenna Factor
2. Emission Level (dBuV/m) = Reading Data + Correction Factor
3. Margin (dB) = Limit – Emission Level
4. The formula transfers the limit at 30 m to 3m is  $L_3 = L_{30} \times (d_{30} / d_3)^2 = L_{30}(\text{dBuV/m}) + 40$

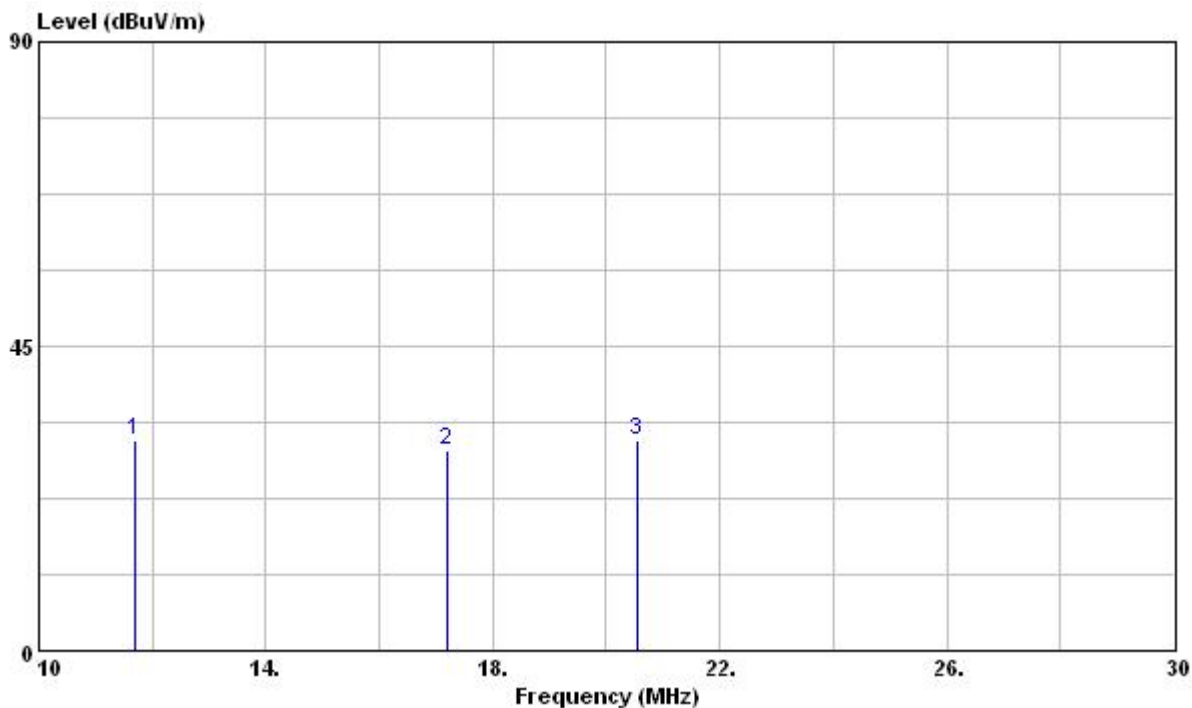

**Test Mode : Mode 1**

**Test Distance : 3m**

**Tester : Jacky**

**Polarization : Vertical**

**Frequency Range : 30MHz~1000MHz**

	Freq. (MHz)	Reading Data (dBuV)	Correction Factor (dB/m)	Emission Level (dBuV/m)	Limit (dBuV/m)	Margin (dB)	Detector
1	30.00	37.47	-8.42	29.05	40.0	10.95	Peak
2	113.16	57.94	-19.18	38.76	43.5	4.74	Peak
3	203.40	58.04	-15.69	42.35	43.5	1.15	Q.P.
4	217.11	54.86	-15.19	39.67	46.0	6.33	Peak
5	533.10	43.24	-6.13	37.11	46.0	8.89	Peak
6	671.70	38.71	-3.94	34.77	46.0	11.23	Peak

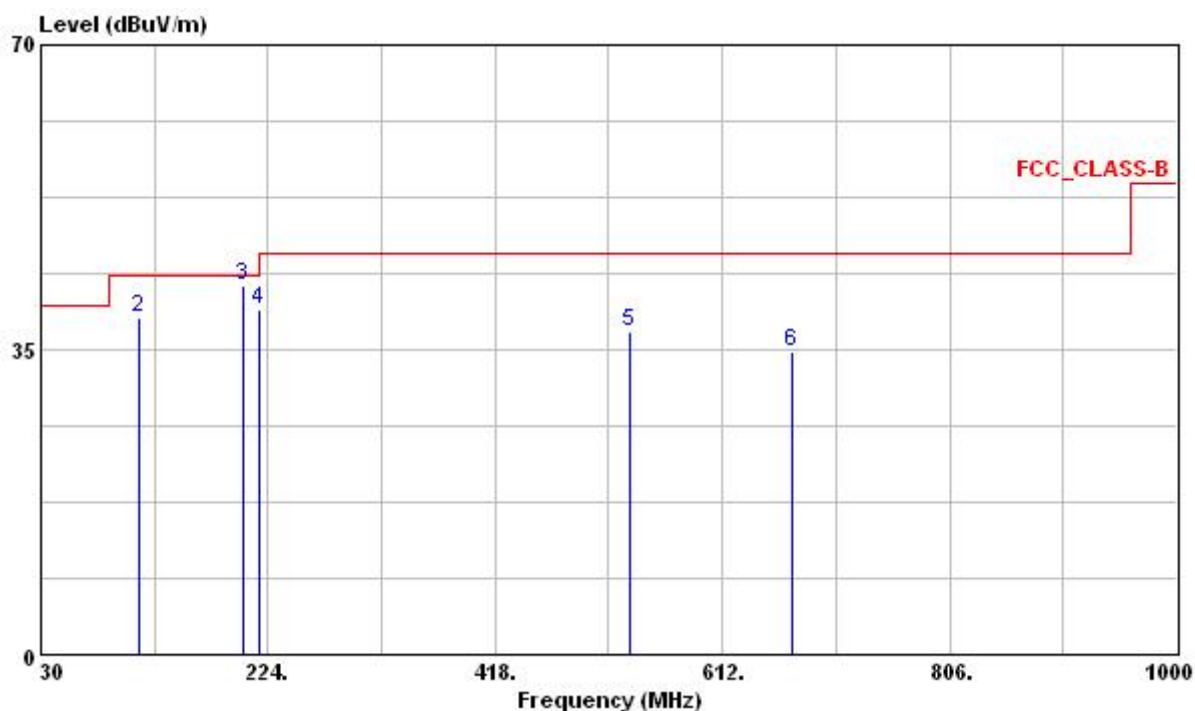

Note :

1. Correction Factor (dB/m) = Cable Loss + Antenna Factor – Gain of Preampifier
2. Emission Level (dBuV/m) = Reading Data + Correction Factor

**Test Mode : Mode 1**

**Test Distance :3m**

**Tester : Jacky**

**Polarization :Horizontal**

**Frequency Range :30MHz~1000MHz**

	Freq. (MHz)	Reading Data (dBuV)	Correction Factor (dB/m)	Emission Level (dBuV/m)	Limit (dBuV/m)	Margin (dB)	Detector
1	113.16	49.59	-19.18	30.41	43.5	13.09	Peak
2	203.40	58.08	-15.69	42.39	43.5	1.11	Peak
3	217.11	55.46	-15.19	40.27	46.0	5.73	Q.P.
4	230.88	52.64	-14.37	38.27	46.0	7.73	Peak
5	387.50	40.22	-9.22	31.00	46.0	15.00	Peak
6	533.10	38.45	-6.13	32.32	46.0	13.68	Peak

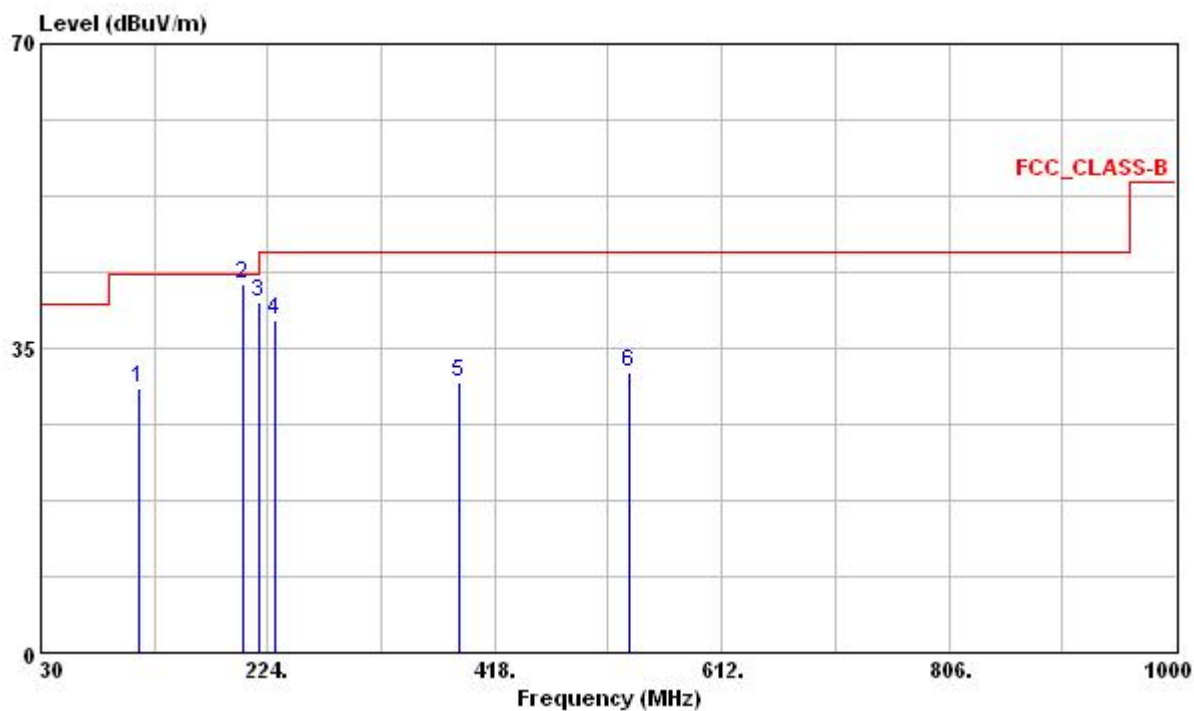

Note :

1. Correction Factor (dB/m) = Cable Loss + Antenna Factor – Gain of Preamplifier
2. Emission Level dBuV/m) = Reading Data + Correction Factor

**Test Mode : Mode 2**

**Test Distance : 3m**

**Tester : Jacky**

**Polarization : Vertical**

**Frequency Range : 10MHz~30MHz**

	Freq. (MHz)	Reading Data (dBuV)	Correction Factor (dB/m)	Emission Level (dBuV/m)	Limit (dBuV/m)	Margin (dB)	Detector
1	12.70	18.49	13.99	32.48	69.54	37.06	Peak
2	19.60	17.30	13.76	31.06	69.54	38.48	Peak
3	20.62	17.83	13.67	31.50	69.54	38.04	Peak

Note:

1. Correction Factor (dB/m) = Cable Loss + Antenna Factor
2. Emission Level (dBuV/m) = Reading Data + Correction Factor
3. Margin (dB) = Limit – Emission Level
4. The formula transfers the limit at 30 m to 3m is  $L_3 = L_{30} \times (d_{30} / d_3)^2 = L_{30}(\text{dBuV/m}) + 40$

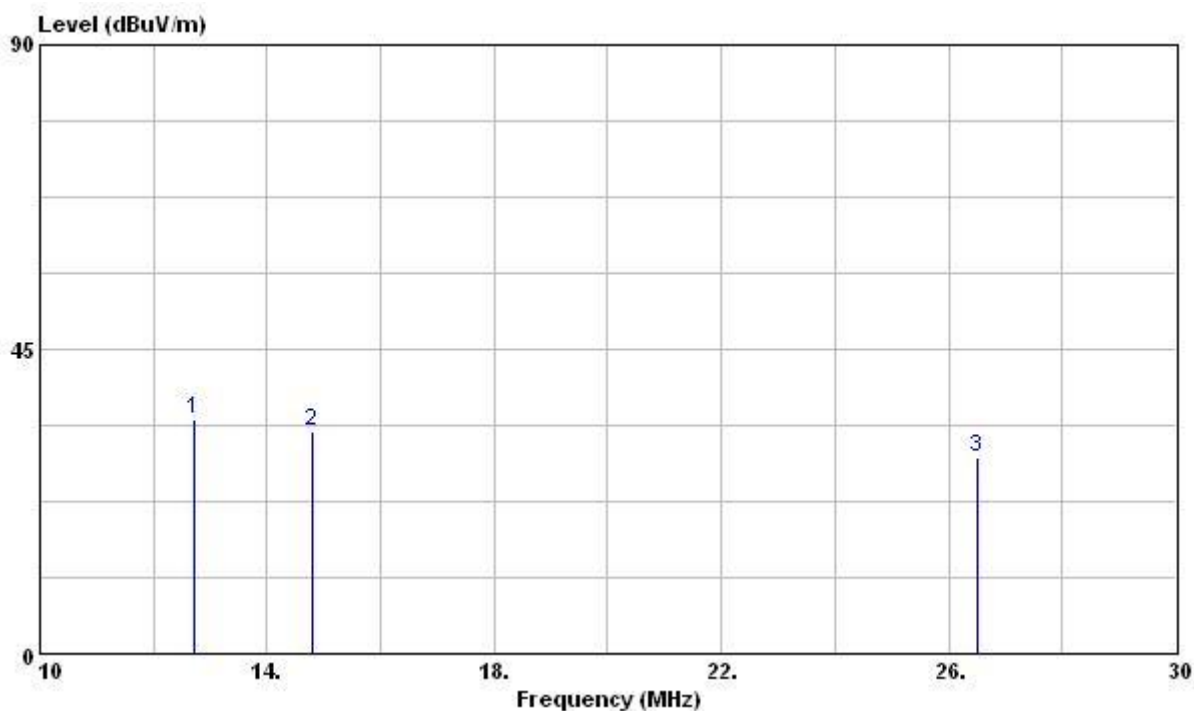

**Test Mode : Mode 2**

**Test Distance :3m**

**Tester : Jacky**

**Polarization : Horizontal**

**Frequency Range : 10MHz~30MHz**

	<b>Freq. (MHz)</b>	<b>Reading Data (dBuV)</b>	<b>Correction Factor (dB/m)</b>	<b>Emission Level (dBuV/m)</b>	<b>Limit (dBuV/m)</b>	<b>Margin (dB)</b>	<b>Detector</b>
1	12.70	20.69	13.99	34.68	69.54	34.86	Peak
2	14.80	18.87	13.94	32.81	69.54	36.73	Peak
3	26.52	16.23	12.80	29.03	69.54	40.51	Peak

Note:

1. Correction Factor (dB/m) = Cable Loss + Antenna Factor
2. Emission Level (dBuV/m) = Reading Data + Correction Factor
3. Margin (dB) = Limit – Emission Level
4. The formula transfers the limit at 30 m to 3m is  $L_3 = L_{30} \times (d_{30} / d_3)^2 = L_{30}(\text{dBuV/m}) + 40$

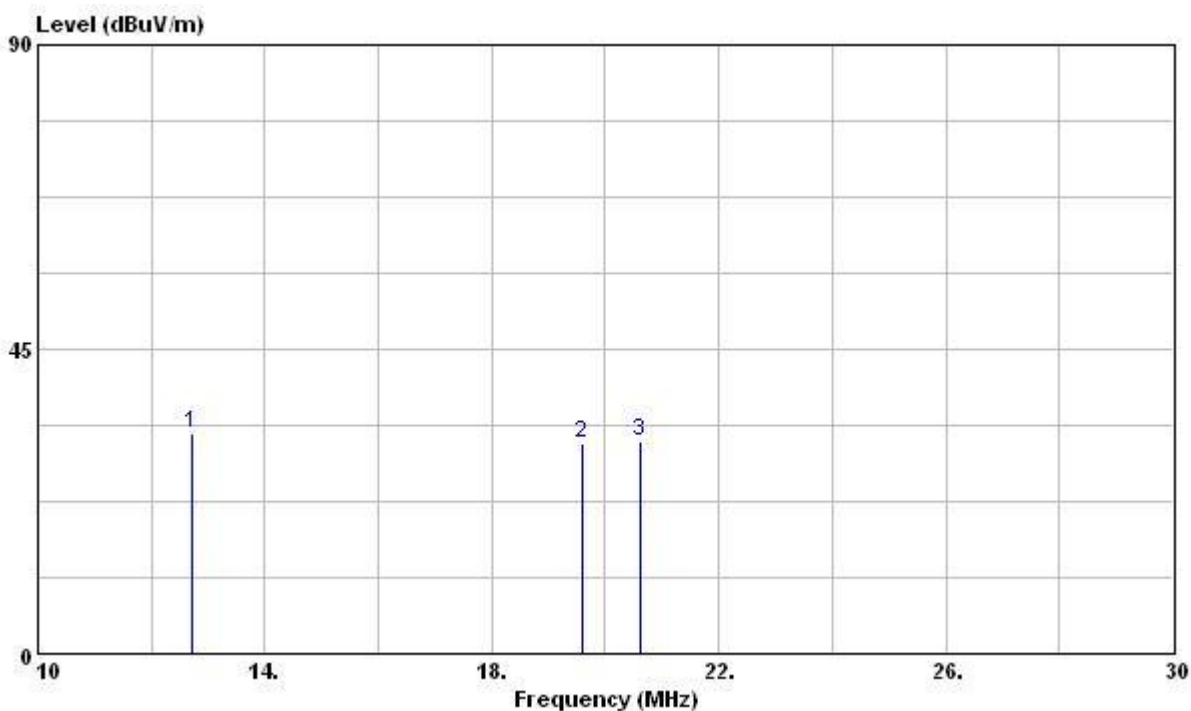

**Test Mode : Mode 2**

**Test Distance : 3m**

**Tester : Jacky**

**Polarization : Vertical**

**Frequency Range : 30MHz~1000MHz**

	Freq. (MHz)	Reading Data (dBuV)	Correction Factor (dB/m)	Emission Level (dBuV/m)	Limit (dBuV/m)	Margin (dB)	Detector
1	105.60	55.42	-18.90	36.52	43.5	6.98	Q.P.
2	163.11	53.77	-16.91	36.86	43.5	6.64	Peak
3	216.95	58.87	-15.20	43.67	46.0	2.33	Q.P.
4	230.88	51.54	-14.37	37.17	46.0	8.83	Peak
5	398.00	38.68	-8.89	29.79	46.0	16.21	Peak
6	531.00	38.68	-6.19	32.49	46.0	13.51	Peak

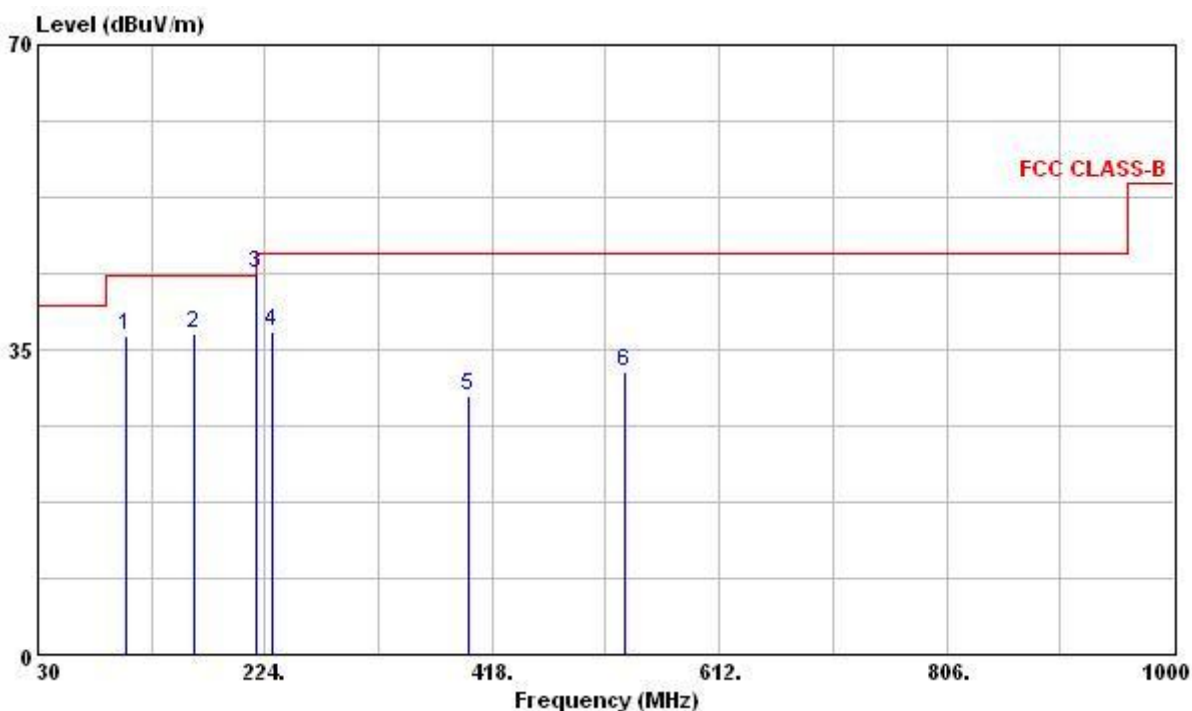

Note :

1. Correction Factor (dB/m) = Cable Loss + Antenna Factor – Gain of Preamplifier
2. Emission Level (dBuV/m) = Reading Data + Correction Factor
3. Q.P is abbreviation of quasi-peak.

**Test Mode : Mode 2**

**Test Distance :3m**

**Tester : Jacky**

**Polarization :Horizontal**

**Frequency Range :30MHz~1000MHz**

	<b>Freq. (MHz)</b>	<b>Reading Data (dBuV)</b>	<b>Correction Factor (dB/m)</b>	<b>Emission Level (dBuV/m)</b>	<b>Limit (dBuV/m)</b>	<b>Margin (dB)</b>	<b>Detector</b>
1	163.11	50.19	-16.91	33.28	43.5	10.22	Peak
2	203.61	54.27	-15.69	38.58	43.5	4.92	Q.P.
3	216.95	59.55	-15.20	44.35	46.0	1.65	Peak
4	230.88	55.12	-14.37	40.75	46.0	5.25	Peak
5	311.90	40.91	-11.86	29.05	46.0	16.95	Peak
6	533.10	39.43	-6.13	33.30	46.0	12.70	Peak

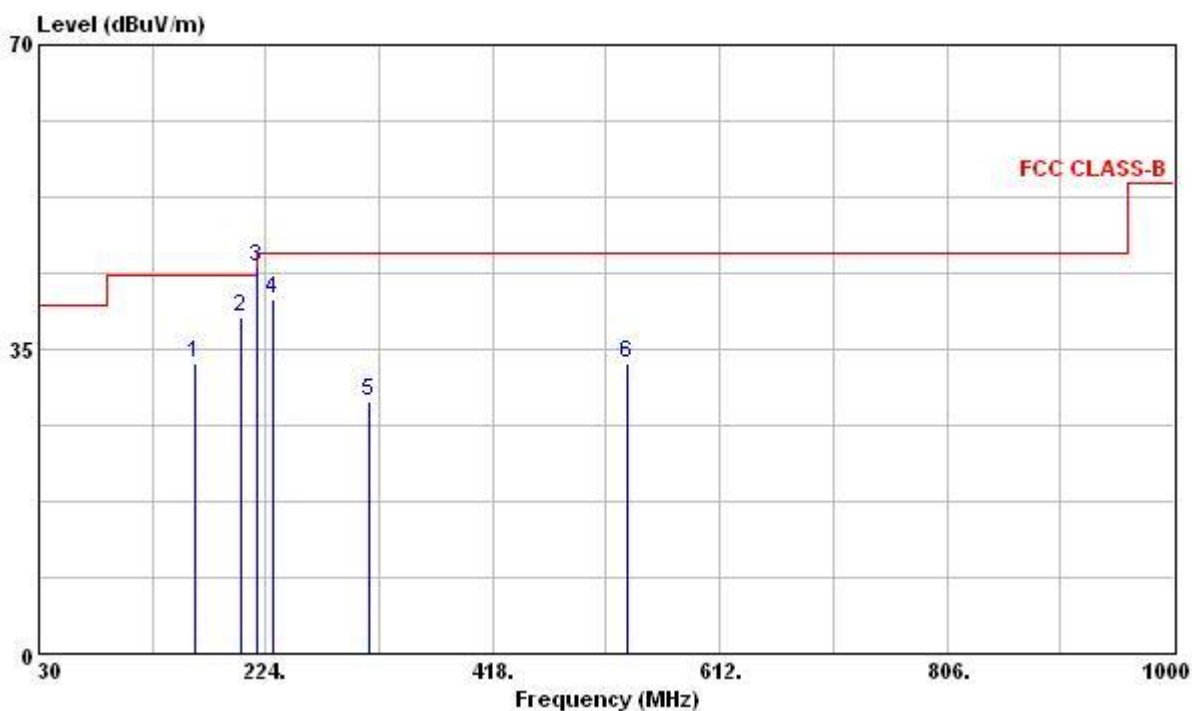

Note :

1. Correction Factor (dB/m) = Cable Loss + Antenna Factor – Gain of Preamplifier
2. Emission Level dBuV/m) = Reading Data + Correction Factor
3. Q.P is abbreviation of quasi-peak.

## 4 Frequency Tolerance

Result: Pass

### 4.1 Applied Standard

According to 15.225(e), the frequency tolerance of the carrier signal shall be maintained within +/- 0.01% of the operating frequency over a temperature variation of -20 degrees to +50 degrees C at normal supply voltage, and for a variation in the primary supply voltage from 85% to 115% of the rated supply voltage at a temperature of 20 degrees C. For battery operated equipment, the equipment tests shall be performed using a new battery.

### 4.2 Test Instruments

Test Site and Equipment	Manufacturer	Model No./ Serial No.	Last Calibration Date	Calibration Due Data
Spectrum Analyzer	Agilent	E4405B/ MY45106706	2008/3/25	2009/3/24
Temperature Chamber	Terchy	MHG-800LF/ 920224	2008/8/7	2009/8/6
Test Site	N.A.	TR13	NCR	NCR

Note:

1. The calibrations are traceable to NML/ROC.
2. NCR : No Calibration Required.

### Instrument Setting

RBW	VBW	Detector	Trace	Comment
300Hz	1kHz	Peak	Maxhold	

### Climatic Condition

Ambient Temperature : 23°C; Relative Humidity : 65%



### 4.3 Measurement Procedure

- a. The EUT was set up per the test configuration figured in the next section of this chapter and to simulate the typical usage described in the user's manual supported by the manufacturer in test site TR13.
- b. Measure the frequency tolerance by using the spectrum analyzer and following the test conditions described in FCC 15.225(e) to perform the normal and extreme test conditions tests.
- c. Record the level and compare with the required limit.

### 4.4 Test Configuration

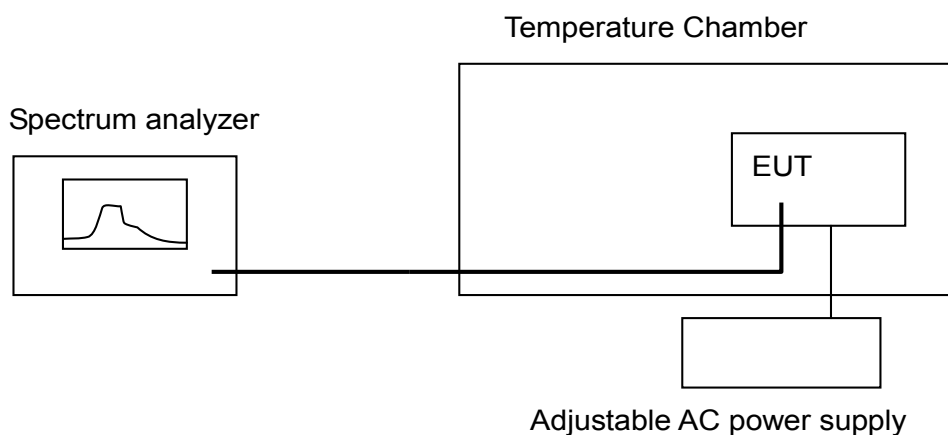

4.5 Test Data

Test Mode : Mode 2

Tester : Bill

Temperature (°C)	AC Voltage (Volt)	Meas. Frequency (MHz)	Deviation (kHz)	Limit (kHz)	Margin (kHz)
20°C	120	13.56044	NA	NA	NA
	138	13.56043	0.01	1.356	1.346
	102	13.56044	0.01	1.356	1.346
-20°C	120	13.56054	0.10	1.356	1.256
50°C	120	13.56049	0.05	1.356	1.306

Note:

1. Deviation(kHz) = | Meas. Frequency – Meas. Frequency @20°C/120Vac |
2. Margin (kHz)= Limit – Deviation

20°C, 120Vac

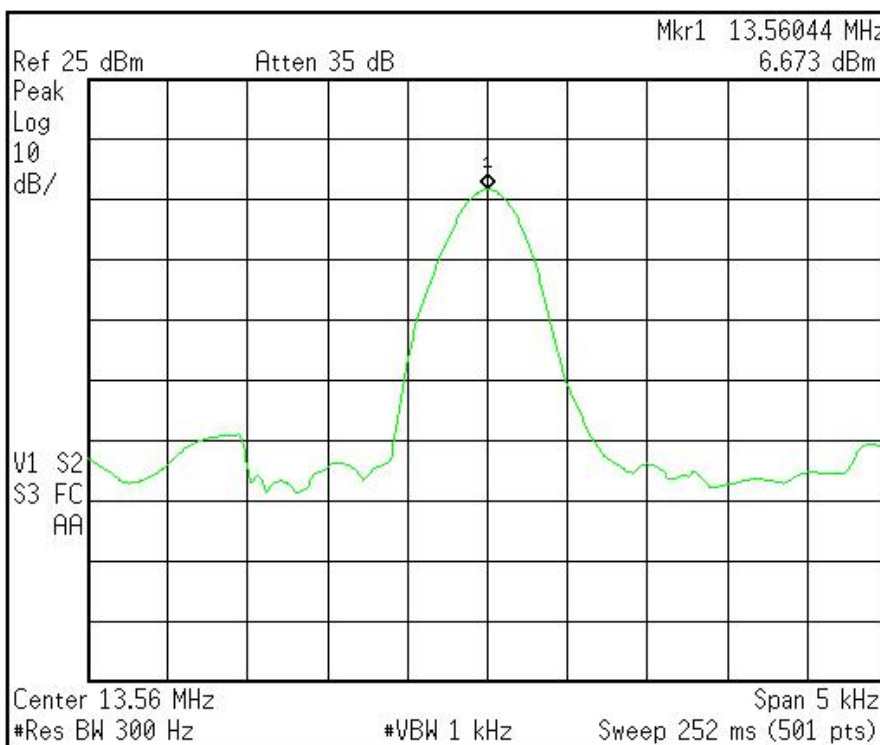

20°C, 138Vac

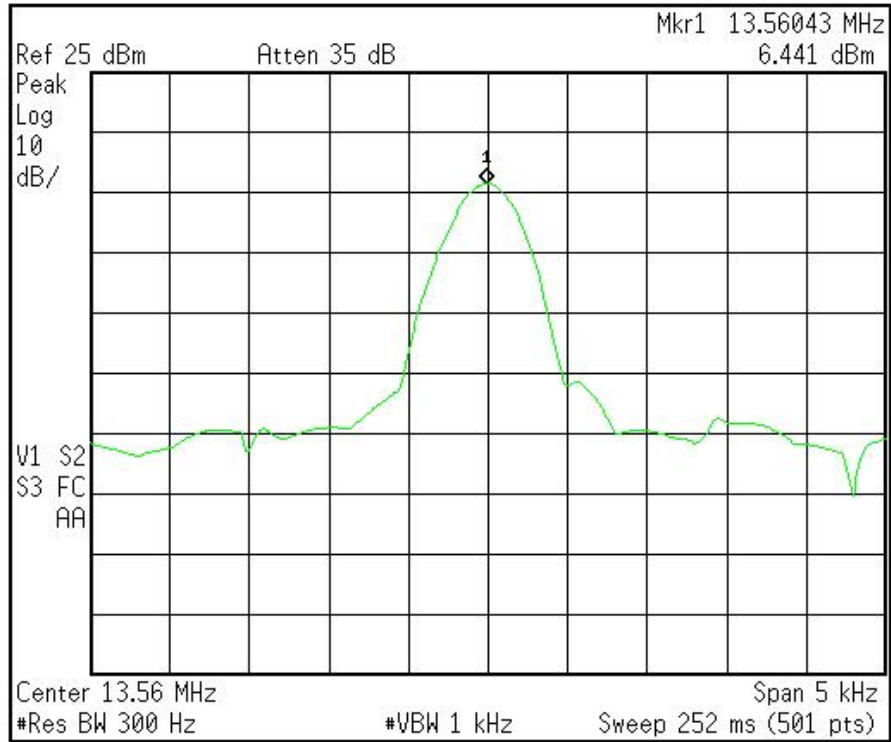

20°C, 102Vac

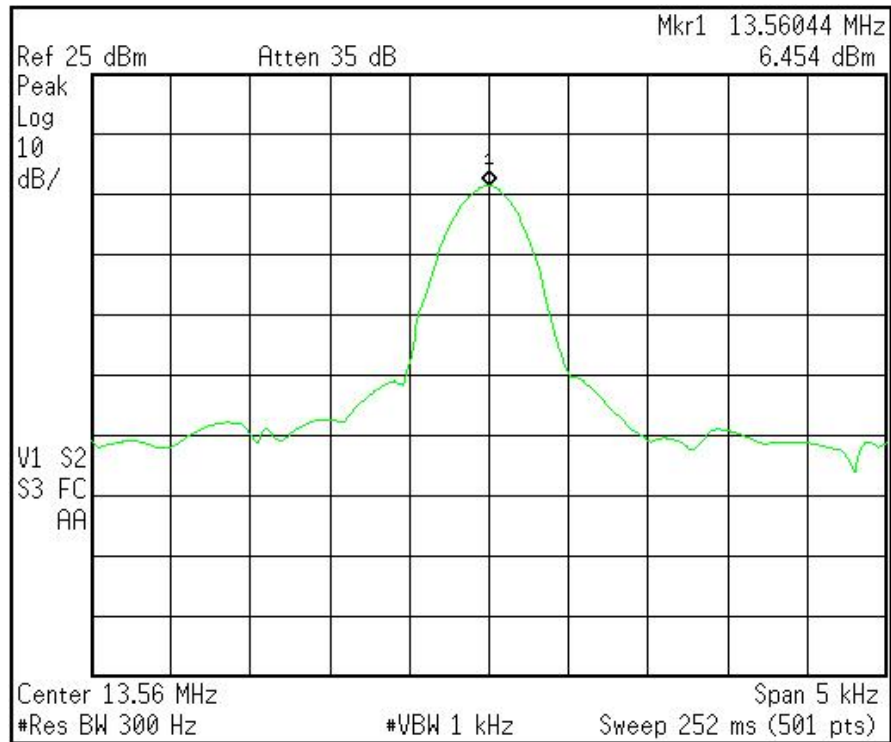

-20°C, 120Vac

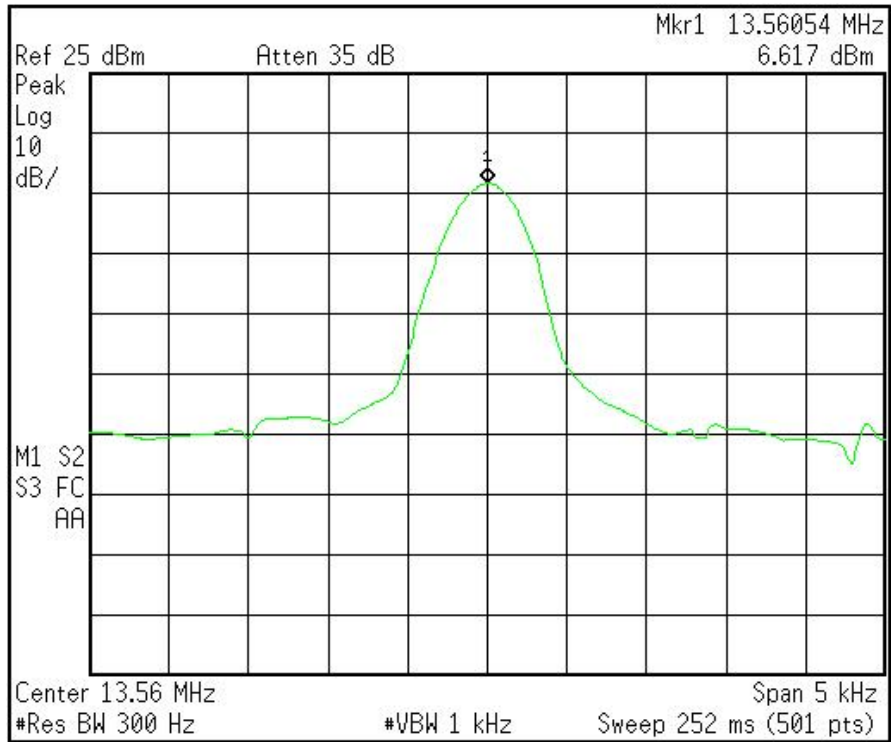

50°C, 120Vac

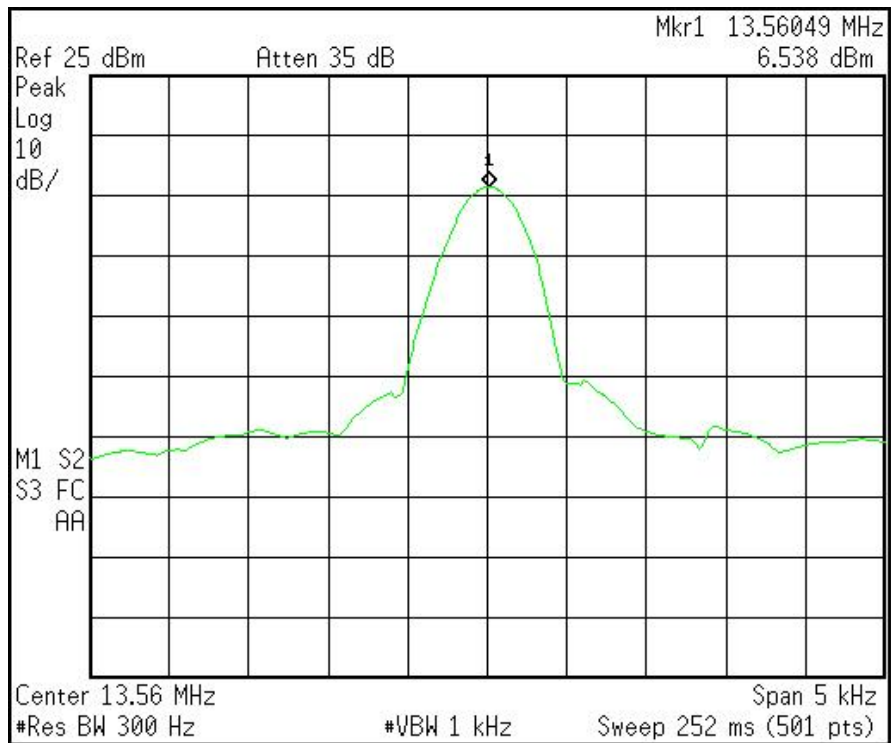

**5 20dB Bandwidth**

**Result: Pass**

**5.1 Applied Standard**

According to 15.215(c) requires the device must be designed to ensure that the 20 dB bandwidth of the emission, or whatever bandwidth may otherwise be specified in the specific rule section under which the equipment operates.

According to 15.225, Operation within the band 13.110 – 14.010 MHz.

**5.2 Test Instruments**

Test Site and Equipment	Manufacturer	Model No./ Serial No.	Last Calibration Date	Calibration Due Data
Spectrum Analyzer	Agilent	E4405B/ MY45106706	2008/3/25	2009/3/24
Test Site	N.A.	TR13	NCR	NCR

Note:

1. The calibrations are traceable to NML/ROC.
2. NCR : No Calibration Required.

**Instrument Setting**

RBW	VBW	Detector	Trace	Comment
300Hz	1kHz	Peak	Maxhold	

**Climatic Condition**

Ambient Temperature : 23°C; Relative Humidity : 65%

### 5.3 Measurement Procedure

- a. The EUT was set up per the test configuration figured in the next section of this chapter and to simulate the typical usage described in the user's manual supported by the manufacturer in chamber TR13.
- b. Measure the 20dB bandwidth by using the spectrum analyzer and following the test conditions described in FCC 15.215.
- c. Record the frequencies and compare with the required limit.

### 5.4 Test Configuration



5.5 Test Data

Test Mode : Mode 2

Tester : Bill

Operating Frequency (MHz)	The lowest frequency (MHz)	The highest frequency (MHz)	Limit (MHz)
13.56	13.56001	13.56082	13.110~14.01

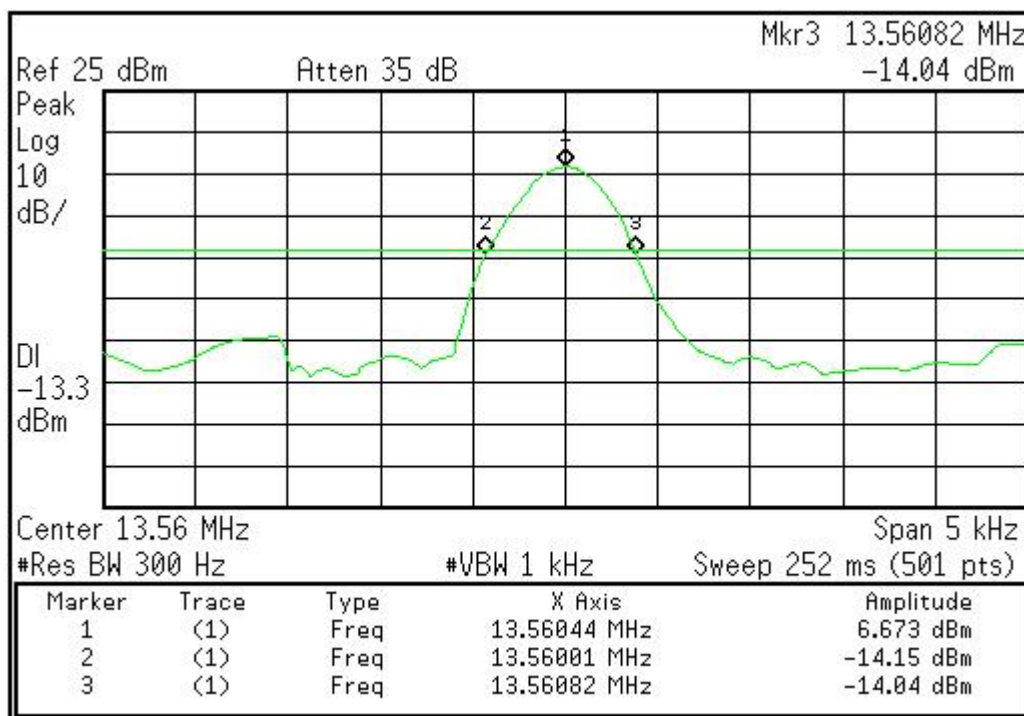

## 6 Conducted Emission Measurement

Test Result: Pass

### 6.1 Limits for Emission Measurement

For intentional device, according to §15.207(a) line conduction emission limit is as below table.

Frequency of Emission (MHz)	Conducted Limit (dBuV)	
	Quasi-peak	Average
0.15 – 0.5	66 to 56*	56 to 46*
0.5 - 5	56	46
5 - 30	60	50

\* Decreases with the logarithm of the frequency.

Note:

For a device with a permanent antenna operating at or below 30 MHz, the FCC will accept measurements done with a suitable dummy load, in lieu of the permanent antenna under the following conditions: (1) perform the AC line conducted tests with the permanent antenna to determine compliance with the Section 15.207 limits outside the transmitter's fundamental emission band; (2) retest with a dummy load in lieu of the permanent antenna to determine compliance with the Section 15.207 limits within the transmitter's fundamental emission band.



## 6.2 Test Instruments

Test Site and Equipment	Manufacturer	Model No./ Serial No.	Last Calibration Date	Calibration Due Date
Test Receiver	R&S	ESCS 30/ 836858/021	2009/1/13	2010/1/12
LISN	R&S	ESH2-Z5/ 836613/001	2008/8/13	2009/8/12
2 <sup>nd</sup> LISN	R&S	ENV4200/ 833209/010	2009/1/13	2010/1/12
50Ω terminator	N/A	N/A/ 001	2008/8/26	2009/8/25
RF Switch	N/A	RSU28/ 338965/002	2008/3/3	2009/3/2
RF Cable	N/A	N/A/ C0052 ~ 56	2008/3/3	2009/3/2
Test Software	Audix	e3/ Ver. 5.4.219.f	NCR	NCR
TR5 shielded room	ETS LINDGREN	TR5/ 15353-F	NCR	NCR

Note:

1. The calibrations are traceable to NML/ROC.
2. NCR : No Calibration Required.

### Instrument Setting

IF BW	Measurement Time	Detector	Trace	Comment
9kHz	1 second	Quasi-Peak / Average	Maxhold	

### Climatic Condition

Ambient Temperature : 27°C;      Relative Humidity : 65%

### 6.3 Test Procedures

- a. The EUT was set up per the test configuration figured in the next section of this chapter to simulate the typical usage per the user's manual.
- b. If the EUT is tabletop equipment, it was placed on a non-conducted table with a height of 0.8 meters above the reference ground plane and 0.4 meters from the conducting wall of the shielded room. Also if the EUT is floor-standing equipment, it was placed on a non-conducted support with a height of 12 millimeters above the reference ground plane.
- c. Connect the EUT's power source to the appropriate power mains through the LISN.
- d. All the other peripherals are connected to the 2<sup>nd</sup> LISN, if any.
- e. The LISN was placed 0.8 meters from the EUT and at least 0.8 meters from other units and other metal planes.
- f. Measure the conducted emissions on each power line (Neutral Line and Line 1 – Hot side) of the EUT's power source by using the test receiver connected to the coupling RF output port of LISN.
- g. Rapidly scan the signal from 150kHz to 30MHz by using the receiver through the Maximum-Peak detector to determine those frequencies associated with higher emission levels for each measured line.
- h. Then measure the maximum level of conducted disturbance for each frequency found from step g. by using the receiver through the Quasi-Peak and Average detectors per CISPR 16-1.
- i. Record the level for each frequency and compare with the required limit.

### 6.4 Test Configurations

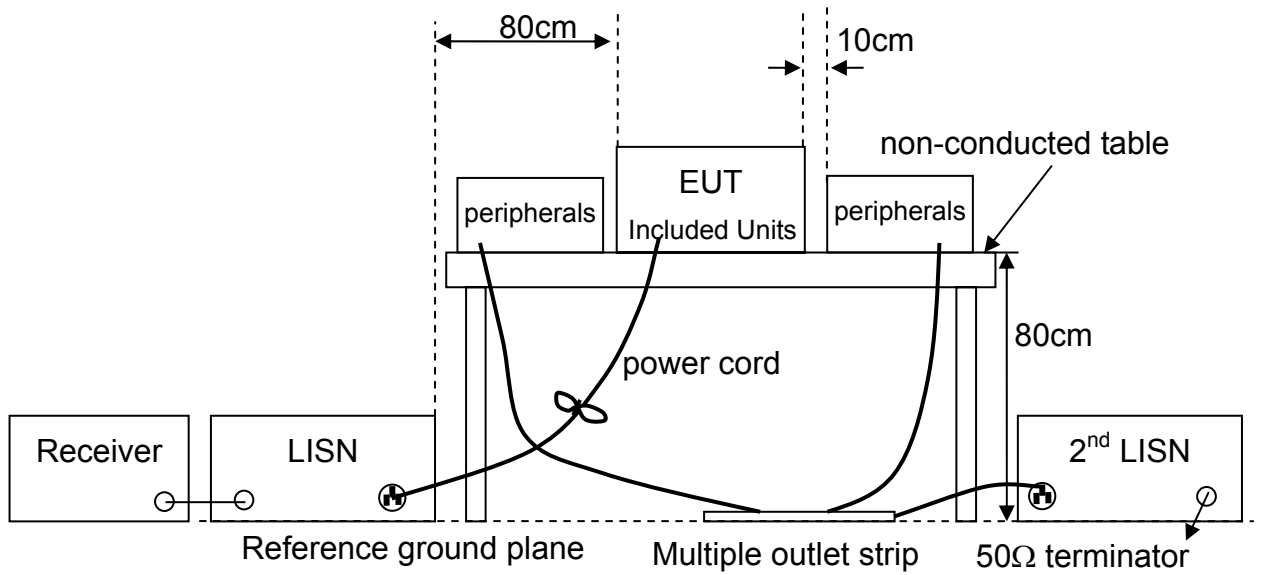

6.5 Test Results

**Test Mode** : Mode 2, Transmitting with antenna  
**Tester** : CDC **Temperature** : 24°C  
**Humidity** : 75%RH **Frequency Range** : 150kHz~30MHz  
**IF Bandwidth** : 9kHz **Phase** : Line

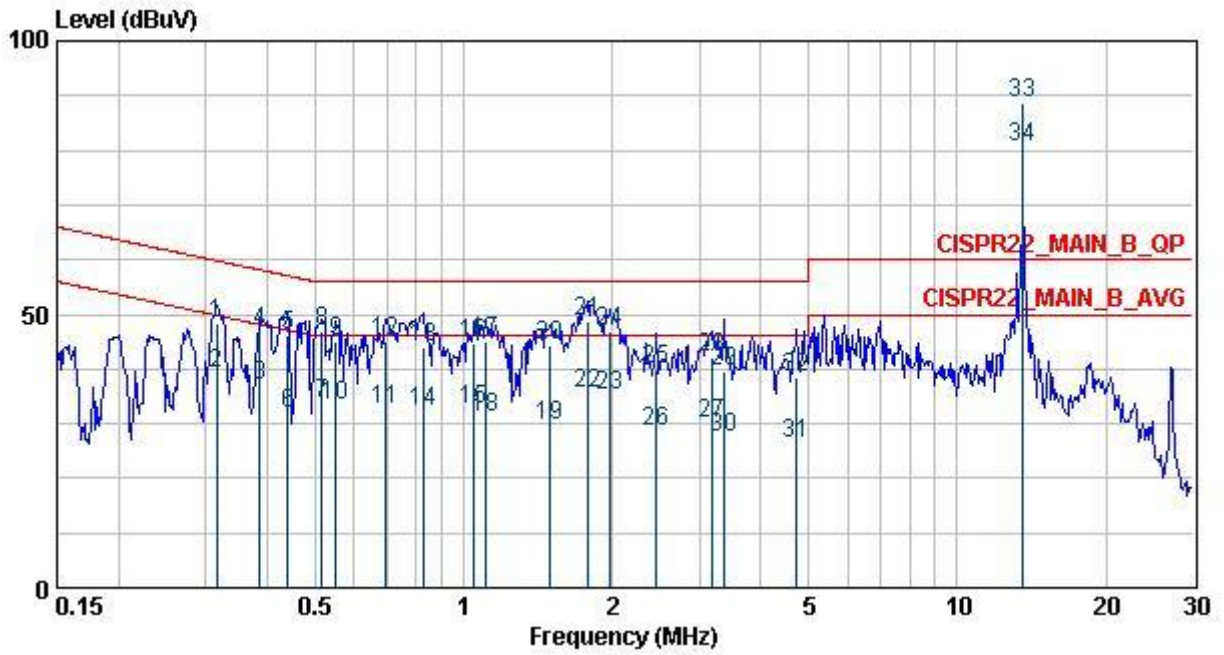

	Freq	Level	Factor	Read Level	Limit Line	Over Limit	Ant		Remark
	MHz	dBuV	dB	dBuV	dBuV	dB	Pos	Pol/Phase	
							cm		
1	0.32	48.31	0.15	48.16	59.80	-11.48	---	LINE	QP
2	0.32	39.17	0.15	39.02	49.80	-10.62	---	LINE	AVERAGE
3	0.39	37.03	0.15	36.88	48.12	-11.09	---	LINE	AVERAGE
4	0.39	46.92	0.15	46.77	58.12	-11.20	---	LINE	QP
5	0.44	46.27	0.15	46.12	57.07	-10.79	---	LINE	QP
6	0.44	31.94	0.15	31.79	47.07	-15.12	---	LINE	AVERAGE
7	0.52	33.61	0.16	33.45	46.00	-12.39	---	LINE	AVERAGE
8	0.52	46.83	0.16	46.67	56.00	-9.17	---	LINE	QP
9	0.55	45.21	0.16	45.05	56.00	-10.79	---	LINE	QP
10	0.55	33.37	0.16	33.21	46.00	-12.63	---	LINE	AVERAGE
11	0.70	32.64	0.17	32.47	46.00	-13.36	---	LINE	AVERAGE
12	0.70	44.90	0.17	44.73	56.00	-11.10	---	LINE	QP
13	0.83	44.10	0.19	43.91	56.00	-11.90	---	LINE	QP
14	0.83	32.22	0.19	32.03	46.00	-13.78	---	LINE	AVERAGE
15	1.05	32.69	0.20	32.49	46.00	-13.31	---	LINE	AVERAGE
16	1.05	44.69	0.20	44.49	56.00	-11.31	---	LINE	QP
17	1.11	45.08	0.21	44.87	56.00	-10.92	---	LINE	QP
18	1.11	31.24	0.21	31.03	46.00	-14.76	---	LINE	AVERAGE
19	1.50	29.66	0.22	29.44	46.00	-16.34	---	LINE	AVERAGE
20	1.50	44.47	0.22	44.25	56.00	-11.53	---	LINE	QP
21	1.78	48.62	0.23	48.39	56.00	-7.38	---	LINE	QP
22	1.78	35.67	0.23	35.44	46.00	-10.33	---	LINE	AVERAGE
23	1.98	35.15	0.24	34.91	46.00	-10.85	---	LINE	AVERAGE
24	1.98	46.86	0.24	46.62	56.00	-9.14	---	LINE	QP
25	2.46	40.06	0.28	39.78	56.00	-15.94	---	LINE	QP
26	2.46	28.55	0.28	28.27	46.00	-17.45	---	LINE	AVERAGE
27	3.17	29.93	0.33	29.60	46.00	-16.07	---	LINE	AVERAGE
28	3.17	42.14	0.33	41.81	56.00	-13.86	---	LINE	QP
29	3.38	39.57	0.34	39.23	56.00	-16.43	---	LINE	QP
30	3.38	27.51	0.34	27.17	46.00	-18.49	---	LINE	AVERAGE
31	4.72	26.45	0.41	26.04	46.00	-19.55	---	LINE	AVERAGE
32	4.72	38.63	0.41	38.22	56.00	-17.37	---	LINE	QP
33 X	13.56	88.46	0.61	87.85	60.00	28.46	---	LINE	QP
34 B	13.56	80.43	0.61	79.82	50.00	30.43	---	LINE	AVERAGE

Note:

Tx Fundamental, for reference only. Please refer to next page.

Test Mode : Mode 2, Transmitting with dummy load  
Tester : CDC Temperature : 24°C  
Humidity : 75%RH Frequency Range : 150kHz~30MHz  
IF Bandwidth : 9kHz Phase : Line

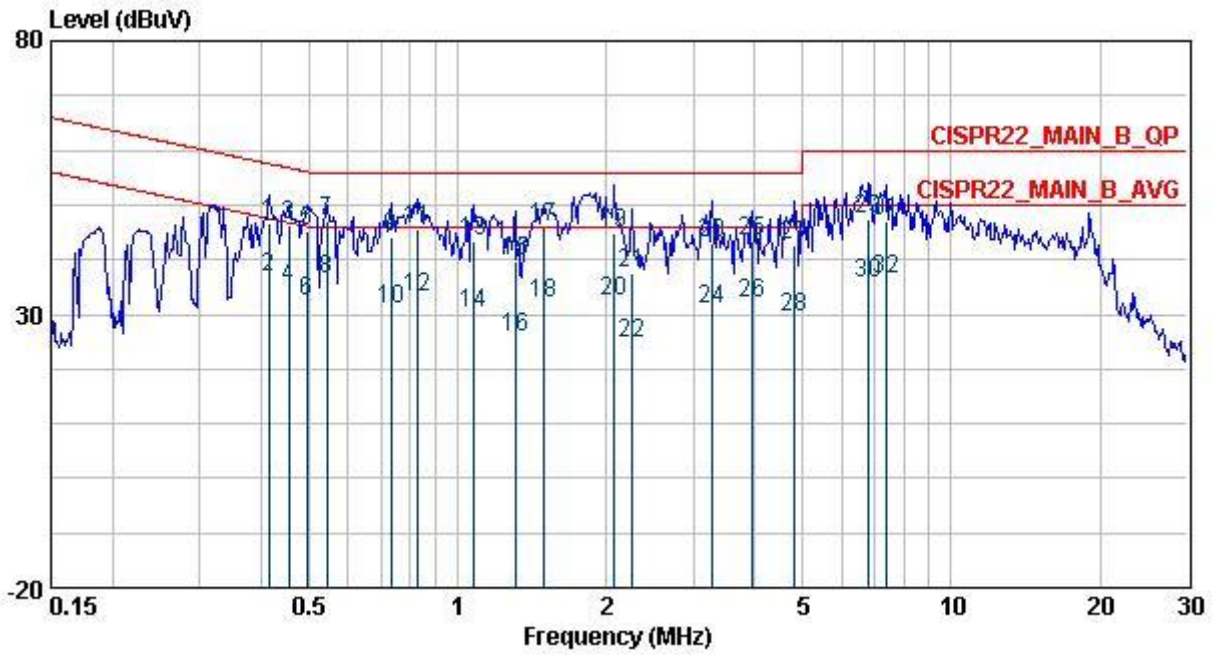

	Freq	Level	Factor	Read Level	Limit Line	Over Limit	Ant Pos	Pol/Phase	Remark
	MHz	dBuV	dB	dBuV	dBuV	dB	cm		
1	0.41	46.66	0.15	46.51	57.55	-10.89	---	LINE	QP
2	0.41	36.88	0.15	36.73	47.55	-10.67	---	LINE	AVERAGE
3	0.45	46.20	0.15	46.05	56.80	-10.60	---	LINE	QP
4	0.45	34.99	0.15	34.84	46.80	-11.81	---	LINE	AVERAGE
5	0.49	45.18	0.16	45.02	56.10	-10.92	---	LINE	QP
6	0.49	32.37	0.16	32.21	46.10	-13.73	---	LINE	AVERAGE
7	0.54	47.12	0.16	46.96	56.00	-8.88	---	LINE	QP
8	0.54	36.24	0.16	36.08	46.00	-9.76	---	LINE	AVERAGE
9	0.73	43.97	0.18	43.79	56.00	-12.03	---	LINE	QP
10	0.73	30.74	0.18	30.56	46.00	-15.26	---	LINE	AVERAGE
11	0.83	45.61	0.19	45.42	56.00	-10.39	---	LINE	QP
12	0.83	32.97	0.19	32.78	46.00	-13.03	---	LINE	AVERAGE
13	1.08	43.47	0.20	43.27	56.00	-12.53	---	LINE	QP
14	1.08	30.02	0.20	29.82	46.00	-15.98	---	LINE	AVERAGE
15	1.31	39.61	0.21	39.40	56.00	-16.39	---	LINE	QP
16	1.31	25.90	0.21	25.69	46.00	-20.10	---	LINE	AVERAGE
17	1.49	45.75	0.22	45.53	56.00	-10.25	---	LINE	QP
18	1.49	32.05	0.22	31.83	46.00	-13.95	---	LINE	AVERAGE
19	2.08	44.88	0.25	44.63	56.00	-11.12	---	LINE	QP
20	2.08	32.41	0.25	32.16	46.00	-13.59	---	LINE	AVERAGE
21	2.25	37.47	0.26	37.21	56.00	-18.53	---	LINE	QP
22	2.25	24.58	0.26	24.32	46.00	-21.42	---	LINE	AVERAGE
23	3.28	42.86	0.34	42.52	56.00	-13.14	---	LINE	QP
24	3.28	30.97	0.34	30.63	46.00	-15.03	---	LINE	AVERAGE
25	3.96	43.34	0.38	42.96	56.00	-12.66	---	LINE	QP
26	3.96	32.02	0.38	31.64	46.00	-13.98	---	LINE	AVERAGE
27	4.82	42.70	0.41	42.29	56.00	-13.30	---	LINE	QP
28	4.82	29.47	0.41	29.06	46.00	-16.53	---	LINE	AVERAGE
29	6.81	47.51	0.52	46.99	60.00	-12.49	---	LINE	QP
30	6.81	35.63	0.52	35.11	50.00	-14.37	---	LINE	AVERAGE
31	7.37	47.03	0.55	46.48	60.00	-12.97	---	LINE	QP
32	7.37	36.27	0.55	35.72	50.00	-13.73	---	LINE	AVERAGE

Note:

1. Emission Level = reading value + correction factor.
2. Correction factor = cable loss + insertion loss of LISN.
3. Q.P. is abbreviation of quasi-peak.

**Test Mode** : Mode 2, Transmitting with antenna  
**Tester** : CDC **Temperature** : 24°C  
**Humidity** : 75%RH **Frequency Range** : 150kHz~30MHz  
**IF Bandwidth** : 9kHz **Phase** : Neutral

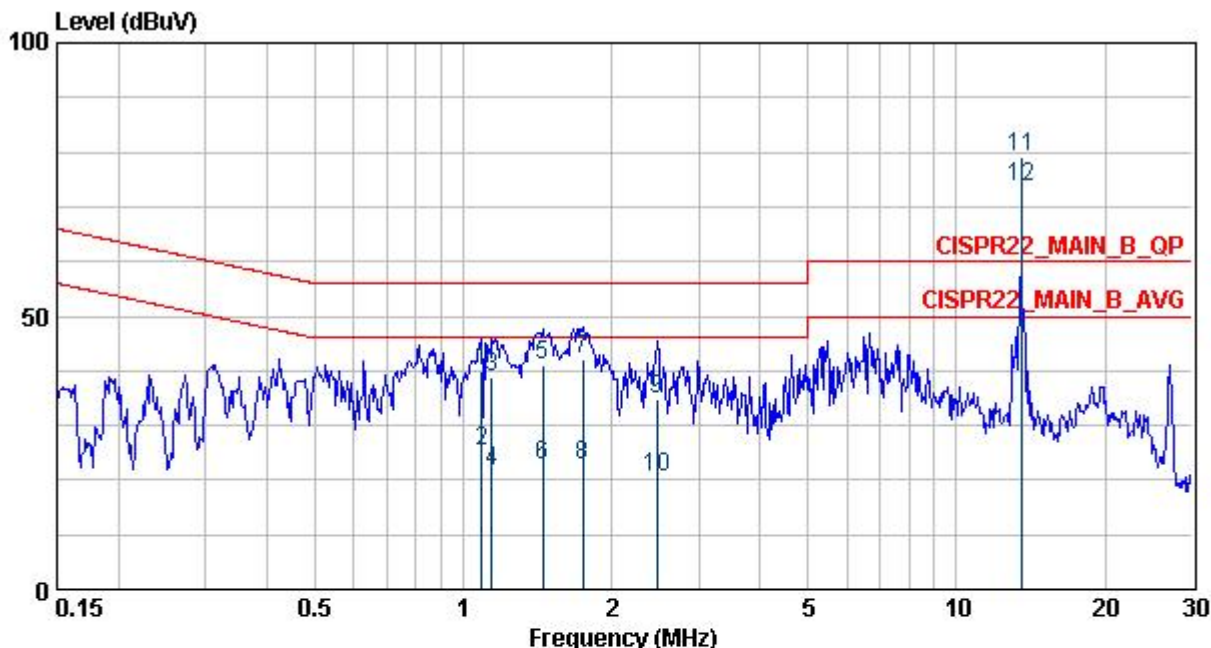

	Freq	Level	Factor	Read Level	Limit Line	Over Limit	Ant Pos	Pol/Phase	Remark
	MHz	dBuV	dB	dBuV	dBuV	dB	cm		
1	1.09	39.92	0.21	39.71	56.00	-16.08	---	NEUTRAL	QP
2	1.09	25.33	0.21	25.12	46.00	-20.67	---	NEUTRAL	AVERAGE
3	1.14	38.85	0.22	38.63	56.00	-17.15	---	NEUTRAL	QP
4	1.14	21.60	0.22	21.38	46.00	-24.40	---	NEUTRAL	AVERAGE
5	1.45	40.89	0.23	40.66	56.00	-15.11	---	NEUTRAL	QP
6	1.45	22.74	0.23	22.51	46.00	-23.26	---	NEUTRAL	AVERAGE
7	1.74	42.11	0.24	41.87	56.00	-13.89	---	NEUTRAL	QP
8	1.74	22.85	0.24	22.61	46.00	-23.15	---	NEUTRAL	AVERAGE
9	2.47	34.89	0.29	34.60	56.00	-21.11	---	NEUTRAL	QP
10	2.47	20.43	0.29	20.14	46.00	-25.57	---	NEUTRAL	AVERAGE
11 X	13.56	79.00	0.95	78.05	60.00	19.00	---	NEUTRAL	QP
12 X	13.56	73.73	0.95	72.78	50.00	23.73	---	NEUTRAL	AVERAGE

Note: Tx Fundamental, for reference only. Please refer to next page.



**Test Mode** : Mode 2, Transmitting with dummy load  
**Tester** : CDC **Temperature** : 24°C  
**Humidity** : 75%RH **Frequency Range** : 150kHz~30MHz  
**IF Bandwidth** : 9kHz **Phase** : Neutral

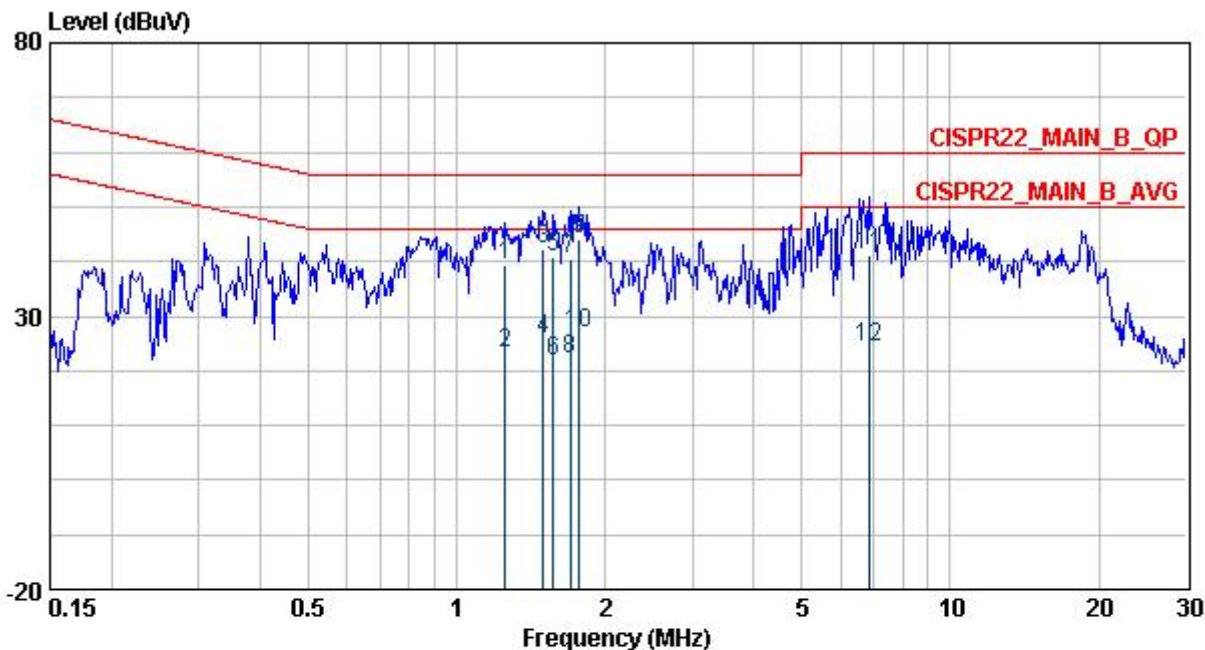

	Freq	Level	Factor	Read Level	Limit Line	Over Limit	Ant Pos	Pol/Phase	Remark
	MHz	dBuV	dB	dBuV	dBuV	dB	cm		
1	1.26	39.22	0.22	39.00	56.00	-16.78	---	NEUTRAL	QP
2	1.26	23.18	0.22	22.96	46.00	-22.82	---	NEUTRAL	AVERAGE
3	1.50	42.43	0.23	42.20	56.00	-13.57	---	NEUTRAL	QP
4	1.50	25.66	0.23	25.43	46.00	-20.34	---	NEUTRAL	AVERAGE
5	1.57	40.68	0.24	40.44	56.00	-15.32	---	NEUTRAL	QP
6	1.57	21.71	0.24	21.47	46.00	-24.29	---	NEUTRAL	AVERAGE
7	1.70	40.40	0.24	40.16	56.00	-15.60	---	NEUTRAL	QP
8	1.70	22.02	0.24	21.78	46.00	-23.98	---	NEUTRAL	AVERAGE
9	1.77	44.18	0.24	43.94	56.00	-11.82	---	NEUTRAL	QP
10	1.77	26.74	0.24	26.50	46.00	-19.26	---	NEUTRAL	AVERAGE
11	6.88	41.20	0.58	40.62	60.00	-18.80	---	NEUTRAL	QP
12	6.88	24.38	0.58	23.80	50.00	-25.62	---	NEUTRAL	AVERAGE

Note:

1. Emission Level = reading value + correction factor.
2. Correction factor = cable loss + insertion loss of LISN.
3. Q.P. is abbreviation of quasi-peak.