



TEST REPORT

Report No.....: **CHEW22070011** Report Verification: 

Project No.....: **SHT2111082706EW**

FCC ID.....: **TEY-A520T**

Applicant's name.....: **ABELL INDUSTRIES CO.,LTD**

Address.....: 701-702, 7/F, D Bldg, Qianwan Hard Technology Industrial Park,
Nanchang community, Xixiang Rd., Bao An Dist., Shenzhen.

Test item description: **Two Way Radio**

Trade Mark: ABELL

Model/Type reference.....: A520T

Listed Model(s): A520TEx, A530T, A530TEx, A550T

Standard: **FCC CFR Title 47 Part 15 Subpart B**

Date of receipt of test sample.....: Jun.15, 2022

Date of testing.....: Jun.16, 2022-Jul.01, 2022

Date of issue.....: Jul.05, 2022

Result.....: **PASS**

Compiled by
 (Position-Printed name-Signature) : File administrators Fanghui Zhu

Supervised by
 (Position-Printed name-Signature) : Project Engineer Caspar Chen

Approved by
 (Position-Printed name-Signature) : RF Manager Hans Hu

Fanghui Zhu

Caspar Chen

Hans Hu

Testing Laboratory Name: **Shenzhen Huatongwei International Inspection Co., Ltd.**

Address.....: 1/F, Bldg 3, Hongfa Hi-tech Industrial Park, Genyu Road, Tianliao,
Gongming, Shenzhen, China

Shenzhen Huatongwei International Inspection Co., Ltd. All rights reserved.

This publication may be reproduced in whole or in part for non-commercial purposes as long as the Shenzhen Huatongwei International Inspection Co., Ltd. is acknowledged as copyright owner and source of the material. Shenzhen Huatongwei International Inspection Co., Ltd. takes no responsibility for and will not assume liability for damages resulting from the reader's interpretation of the reproduced material due to its placement and context.

The test report merely corresponds to the test sample.

Contents

1.	<u>TEST STANDARDS AND REPORT VERSION</u>	<u>3</u>
1.1.	Test Standards	3
1.2.	Report version	3
2.	<u>TEST DESCRIPTION</u>	<u>4</u>
3.	<u>SUMMARY.....</u>	<u>5</u>
3.1.	Client information	5
3.2.	Product description	5
3.3.	Radio Specification Description	5
3.4.	Testing Laboratory Information	6
4.	<u>TEST CONFIGURATION.....</u>	<u>7</u>
4.1.	Operation mode	7
4.2.	Support unit used in test configuration and system	7
4.3.	Testing environmental condition	7
4.4.	Statement of the measurement uncertainty	7
4.5.	Equipments Used during the Test	8
5.	<u>TEST CONDITIONS AND RESULTS</u>	<u>9</u>
5.1.	Conducted Emissions	9
5.2.	Radiated Emissions	12
6.	<u>TEST SETUP PHOTOS OF THE EUT</u>	<u>22</u>
7.	<u>EXTERNAL AND INTERNAL PHOTOS OF THE EUT</u>	<u>23</u>

1. TEST STANDARDS AND REPORT VERSION

1.1. Test Standards

The tests were performed according to following standards:

[FCC CFR Title 47 Part 15 Subpart B](#) - Unintentional Radiators

[ANSI C63.4: 2014](#) – American National Standard for Methods of Measurement of Radio-Noise Emissions from Low-Voltage Electrical and Electronic Equipment in the Range of 9 kHz to 40GHz

1.2. Report version

Revision No.	Date of issue	Description
N/A	2022-07-05	Original

2. TEST DESCRIPTION

Section	Test Item	Section in CFR 47	Result	Test Engineer
5.1	Conducted Emissions	15.107(a)	Pass	Quanhai Deng
5.2	Radiated Emissions	15.109(a)	Pass	Hongtao Meng

Note:

1. The measurement uncertainty is not included in the test result.

3. SUMMARY

3.1. Client information

Applicant:	ABELL INDUSTRIES CO.,LTD
Address:	701-702, 7/F, D Bldg, Qianwan Hard Technology Industrial Park, Nanchang community, Xixiang Rd., Bao An Dist., Shenzhen.
Manufacturer:	ABELL INDUSTRIES CO.,LTD
Address:	701-702, 7/F, D Bldg, Qianwan Hard Technology Industrial Park, Nanchang community, Xixiang Rd., Bao An Dist., Shenzhen.

3.2. Product description

Name of EUT:	Two Way Radio
Trade mark:	ABELL
Model/Type reference:	A520T
Listed model(s):	A520TEx、A530T、A530TEx、A550T
Power supply:	DC7.4V
Battery information:	Model:AB-L2252 7.4V d.c., 2200mA/16Wh
Charger information:	Model: BC-780A Input: 12V d.c., 1000mA Output: 600mA d.c.
Adapter information:	Model:DSA-12PFT-12 FUS 120100 Input:100-240Va.c., 50/60Hz 0.5A Output:12Vd.c., 1A
Hardware version:	V1
Software version:	V1.07.01

3.3. Radio Specification Description

Support Frequency Range:	400MHz~480MHz	
Rated Output Power:	<input checked="" type="checkbox"/> High Power: 4.5W	<input checked="" type="checkbox"/> Low Power: 1.5W
Modulation Type:	Analog:	FM
	Digital :	4FSK
Supported Digital Protocol:	DMR	
Channel Separation:	Analog:	<input checked="" type="checkbox"/> 12.5kHz
	Digital :	<input type="checkbox"/> 6.25kHz <input checked="" type="checkbox"/> 12.5kHz
Emission Designator:	Analog:	11K0F3E
	Digital:	7K60FXW, 7K60FXD
Support data rate:	9.6kbps	

Antenna Type:	External
Antenna Gain:	0dBi

3.4. Testing Laboratory Information

Laboratory Name	Shenzhen Huatongwei International Inspection Co., Ltd.	
Laboratory Location	1/F, Bldg 3, Hongfa Hi-tech Industrial Park, Genyu Road, Tianliao, Gongming, Shenzhen, China	
Connect information:	Tel: 86-755-26715499 E-mail: cs@szhtw.com.cn http://www.szhtw.com.cn	
Qualifications	Type	Accreditation Number
	FCC Test Firm Registration Number	762235
	FCC Designation Number	CN1181

4. TEST CONFIGURATION

4.1. Operation mode

Test mode	Describe
Charging mode	Keep the EUT in charging mode, but the EUT shut down.
Receive mode	Keep the EUT in receiving mode, but don't charging.

Receive frequency: 450MHz

Section	Test item	Test mode
5.1	Conducted emissions	Charging mode
5.2	Radiated emissions	Charging mode, receive mode

Only show the test data for worse case mode on the test report.

4.2. Support unit used in test configuration and system

The EUT has been associated with peripherals and configuration operated in a manner tended to maximize its emission characteristics in a typical application.

The following peripheral devices and interface cables were connected during the measurement:

Whether support unit is used?			
✓ No			
Item	Equipement	Trade Name	Model No.
1			
2			

4.3. Testing environmental condition

Type	Requirement	Actual
Temperature:	15~35°C	25°C
Relative Humidity:	25~75%	50%
Air Pressure:	860~1060mbar	1000mbar

4.4. Statement of the measurement uncertainty

Test	Frequency range	Measurement uncertainty
Radiated Emission	30~1000MHz	4.90 dB
Radiated Emission	1~18GHz	4.96 dB
Conducted Disturbance	0.15~30MHz	3.02 dB

This uncertainty represents an expanded uncertainty expressed at approximately the 95% confidence level using a coverage factor of k=1.96.

4.5. Equipments Used during the Test

● Conducted Emission							
Used	Test Equipment	Manufacturer	Equipment No.	Model No.	Serial No.	Last Cal. Date (YY-MM-DD)	Next Cal. Date (YY-MM-DD)
●	Shielded Room	Albatross projects	HTWE0114	N/A	N/A	2018/09/28	2023/09/27
●	EMI Test Receiver	R&S	HTWE0111	ESCI	101247	2021/09/14	2022/09/13
●	Artificial Mains	SCHWARZBECK	HTWE0113	NNLK 8121	573	2021/09/17	2022/09/16
●	Pulse Limiter	R&S	HTWE0193	ESH3-Z2	101447	2021/09/16	2022/09/15
●	RF Connection Cable	HUBER+SUHNER	HTWE0113-02	ENVIROFLEX_142	EF-NM-BNCM-2M	2021/09/17	2022/09/16
●	Test Software	R&S	N/A	ES-K1	N/A	N/A	N/A

● Radiated Emission-6th test site							
Used	Test Equipment	Manufacturer	Equipment No.	Model No.	Serial No.	Last Cal. Date (YY-MM-DD)	Next Cal. Date (YY-MM-DD)
●	Semi-Anechoic Chamber	Albatross projects	HTWE0127	SAC-3m-02	C11121	2018/09/30	2022/09/29
●	EMI Test Receiver	R&S	HTWE0099	ESCI	100900	2021/09/14	2022/09/13
●	Ultra-Broadband Antenna	SCHWARZBECK	HTWE0119	VULB9163	546	2020/04/28	2023/04/27
●	Pre-Amplifier	SCHWARZBECK	HTWE0295	BBV 9742	N/A	2021/11/05	2022/11/04
●	RF Connection Cable	HUBER+SUHNER	HTWE0062-01	N/A	N/A	2022/02/25	2023/02/24
●	RF Connection Cable	HUBER+SUHNER	HTWE0062-02	SUCOFLEX104	501184/4	2022/02/25	2023/02/24
●	Test Software	R&S	N/A	ES-K1	N/A	N/A	N/A

● Radiated emission-7th test site							
Used	Test Equipment	Manufacturer	Equipment No.	Model No.	Serial No.	Last Cal. Date (YY-MM-DD)	Next Cal. Date (YY-MM-DD)
●	Semi-Anechoic Chamber	Albatross projects	HTWE0122	SAC-3m-01	C11121	2018/09/27	2022/09/26
●	Spectrum Analyzer	R&S	HTWE0098	FSP40	100597	2021/09/13	2022/09/12
●	Horn Antenna	SCHWARZBECK	HTWE0126	9120D	1011	2020/04/01	2023/03/31
●	Broadband Pre-amplifier	SCHWARZBECK	HTWE0201	BBV 9718	9718-248	2022/02/28	2023/02/27
●	RF Connection Cable	HUBER+SUHNER	HTWE0126-01	RE-7-FH	N/A	2022/03/04	2023/03/03
●	Test Software	Audix	N/A	E3	N/A	N/A	N/A

5. TEST CONDITIONS AND RESULTS

5.1. Conducted Emissions

LIMIT

FCC CFR Title 47 Part 15 Subpart B Section 15.107:

Frequency range (MHz)	Limit (dBuV)	
	Quasi-peak	Average
0.15-0.5	66 to 56*	56 to 46*
0.5-5	56	46
5-30	60	50

* Decreases with the logarithm of the frequency.

TEST CONFIGURATION

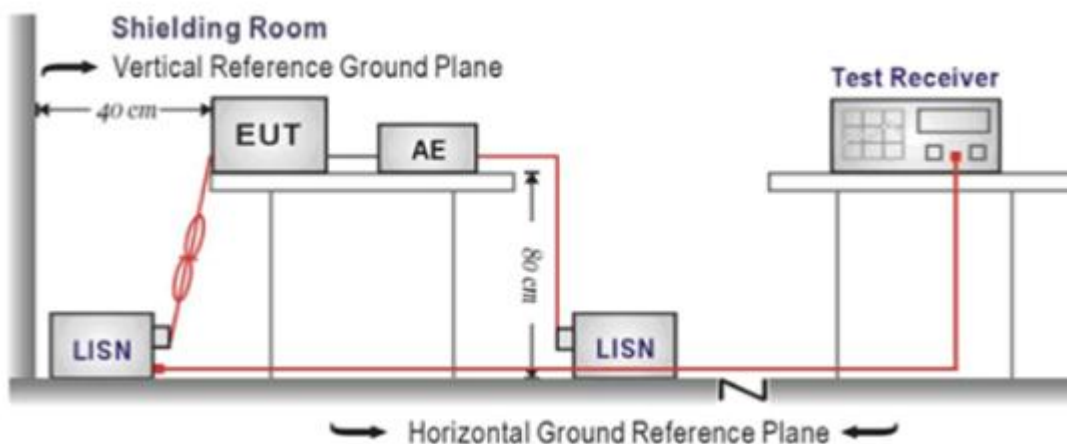

TEST PROCEDURE

1. The EUT was setup according to ANSI C63.4
2. The EUT was placed on a plat form of nominal size, 1 m by 1.5 m, raised 10 cm above the conducting ground plane. The vertical conducting plane was located 40 cm to the rear of the EUT. All other surfaces of EUT were at least 10 cm from any other grounded conducting surface.
3. The EUT and simulators are connected to the main power through a line impedance stabilization network (LISN). The LISN provides a 50ohm / 50uH coupling impedance for the measuring equipment.
4. The peripheral devices are also connected to the main power through a LISN. (Please refer to the block diagram of the test setup and photographs)
5. Each current-carrying conductor of the EUT power cord, except the ground (safety) conductor, was individually connected through a LISN to the input power source.
6. The excess length of the power cord between the EUT and the LISN receptacle were folded back and forth at the center of the lead to form a bundle not exceeding 40 cm in length.
7. Conducted emissions were investigated over the frequency range from 0.15MHz to 30MHz using a receiver bandwidth of 9 kHz.
8. During the above scans, the emissions were maximized by cable manipulation.

TEST MODE:

Please refer to the clause 4.1

TEST RESULTS

Passed Not Applicable

Test Line: L

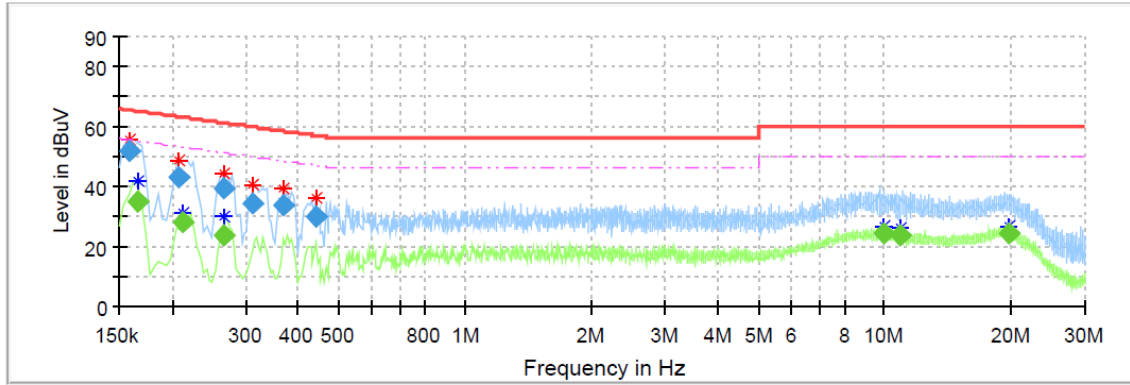

Frequency (MHz)	QuasiPeak (dBuV)	CAverage (dBuV)	Limit (dBuV)	Margin (dB)	Line	Corr. (dB)
0.158000	52.01	---	65.57	13.56	L1	10.1
0.166000	---	34.99	55.16	20.17	L1	10.1
0.207500	43.43	---	63.30	19.87	L1	10.1
0.211500	---	28.33	53.15	24.82	L1	10.1
0.267500	---	23.97	51.20	27.22	L1	10.1
0.267500	39.53	---	61.20	21.67	L1	10.1
0.311500	34.44	---	59.93	25.49	L1	10.1
0.367500	33.62	---	58.56	24.94	L1	10.1
0.443500	30.25	---	57.00	26.75	L1	10.1
9.940500	---	24.20	50.00	25.80	L1	10.5
10.839500	---	23.92	50.00	26.08	L1	10.5
19.755500	---	24.53	50.00	25.47	L1	10.8

Test Line:

N

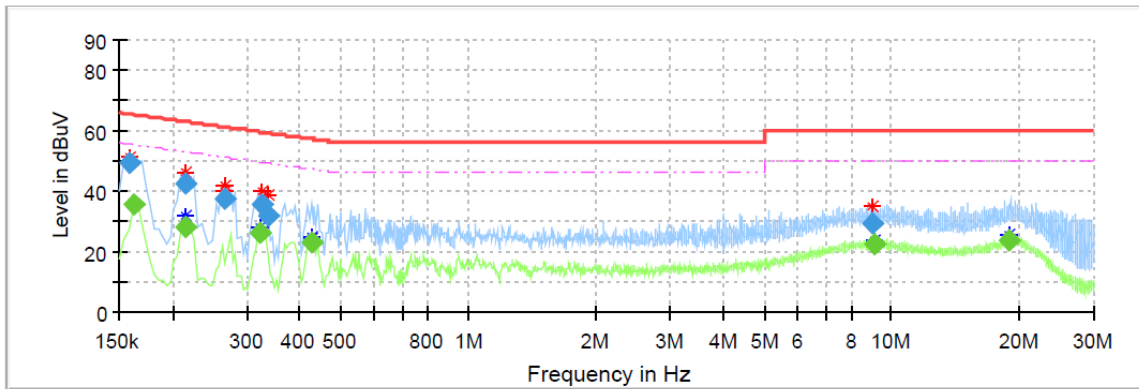

Frequency (MHz)	QuasiPeak (dBuV)	CAverage (dBuV)	Limit (dBuV)	Margin (dB)	Line	Corr. (dB)
0.158000	49.25	---	65.57	16.32	N	10.1
0.162000	---	35.70	55.36	19.66	N	10.1
0.215500	42.79	---	62.99	20.20	N	10.1
0.215500	---	27.90	52.99	25.09	N	10.1
0.267500	37.72	---	61.20	23.48	N	10.1
0.323500	---	26.08	49.62	23.54	N	10.1
0.327500	35.76	---	59.51	23.76	N	10.1
0.335500	31.82	---	59.31	27.50	N	10.1
0.427500	---	23.06	47.30	24.24	N	10.1
9.047500	29.15	---	60.00	30.85	N	10.3
9.155500	---	22.54	50.00	27.46	N	10.3
18.999500	---	23.82	50.00	26.18	N	10.7

5.2. Radiated Emissions

LIMIT

FCC CFR Title 47 Part 15 Subpart B Section 15.109

Frequency	Limit (dBuV/m @3m)	Value
30MHz-88MHz	40.00	Quasi-peak
88MHz-216MHz	43.50	Quasi-peak
216MHz-960MHz	46.00	Quasi-peak
960MHz-1GHz	54.00	Quasi-peak
Above 1GHz	54.00	Average
	74.00	Peak

TEST CONFIGURATION

➤ 30MHz ~ 1GHz

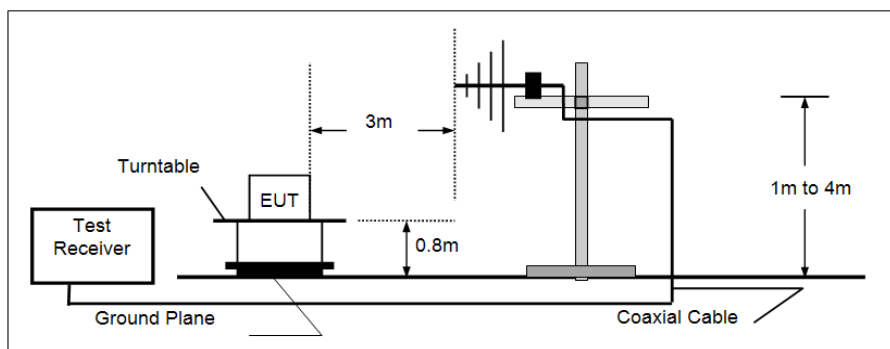

➤ Above 1GHz

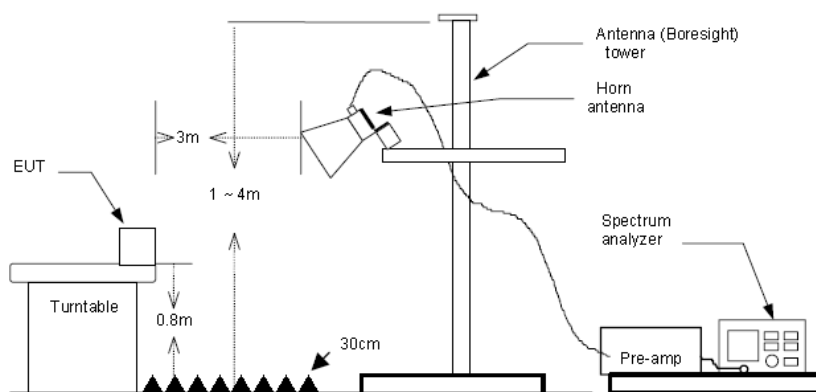

TEST PROCEDURE

- The EUT was tested according to ANSI C63.4.
- The EUT is placed on a turn table which is 0.8 meter above ground.
- The turn table is rotated 360 degrees to determine the position of the maximum emission level.
- The EUT was positioned such that the distance from antenna to the EUT was 3 meters.
- The antenna is scanned from 1 meter to 4 meters to find out the maximum emission level. This is repeated for both horizontal and vertical polarization of the antenna.
- Use the following spectrum analyzer settings
 - Span shall wide enough to fully capture the emission being measured;
 - Below 1GHz,
RBW=120KHz, VBW=300KHz, Sweep=auto, Detector function=peak, Trace=max hold;
If the emission level of the EUT measured by the peak detector is 3 dB lower than the applicable limit, the peak emission level will be reported. Otherwise, the emission measurement will be repeated using the quasi-peak detector and reported.
 - From 1GHz to 5th harmonic, RBW=1MHz, VBW=3MHz

TEST MODE:

Please refer to the clause 4.1

TEST RESULTS

Passed **Not Applicable**

Note: Final Level = Receiver Read level + Antenna Factor + Cable Loss – Preamplifier Factor
The emission levels of frequency above 6GHz are very lower than limit and not show in test report.

Test mode	Charging mode	Polarization:	Horizontal
-----------	---------------	---------------	------------

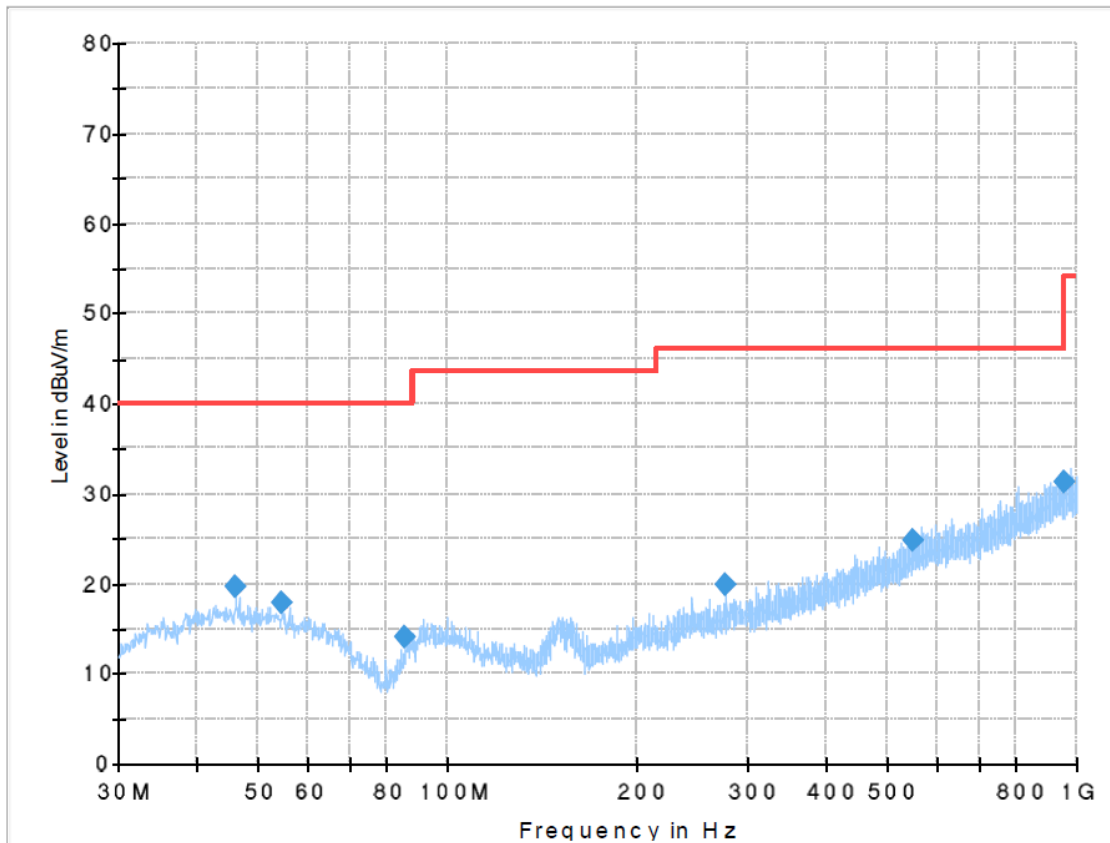

Frequency (MHz)	MaxPeak (dBuV/m)	Limit (dBuV/m)	Margin (dB)	Height (cm)	Pol	Azimuth (deg)	Corr. (dB/m)
46.005000	19.62	40.00	20.38	100.0	H	277.0	-9.3
54.613750	17.94	40.00	22.06	100.0	H	0.0	-9.5
85.775000	14.13	40.00	25.87	100.0	H	309.0	-13.9
276.865000	19.99	46.00	26.01	300.0	H	120.0	-8.2
550.768750	24.89	46.00	21.11	300.0	H	256.0	-0.4
958.290000	31.26	46.00	14.74	100.0	H	266.0	7.4

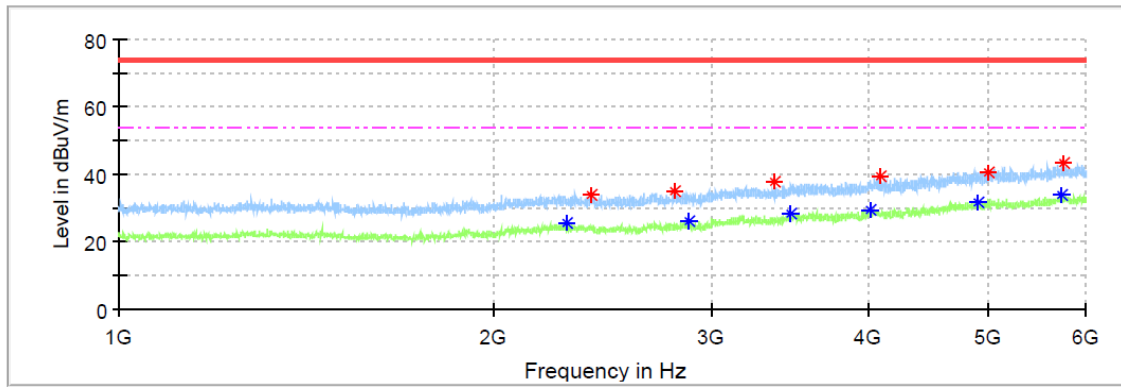

Frequency (MHz)	MaxPeak (dBuV/m)	Average (dBuV/m)	Limit (dBuV/m)	Margin (dB)	Height (cm)	Pol	Azimuth (deg)	Corr. (dB/m)
2795.625000	34.83	---	74.00	39.17	150.0	H	0.0	-3.8
3474.375000	---	28.46	54.00	25.54	150.0	H	0.0	-1.5
4916.250000	---	31.85	54.00	22.15	150.0	H	0.0	5.4
5007.500000	40.77	---	74.00	33.23	150.0	H	0.0	5.9
5752.500000	43.14	---	74.00	30.86	150.0	H	0.0	7.8
3365.625000	37.75	---	74.00	36.25	150.0	H	135.0	-2.6
2398.750000	34.05	---	74.00	39.95	150.0	H	232.0	-4.8
4018.125000	---	29.66	54.00	24.34	150.0	H	246.0	0.6
4105.000000	39.25	---	74.00	34.75	150.0	H	260.0	0.9
2291.250000	---	25.64	54.00	28.36	150.0	H	343.0	-5.0
2877.500000	---	26.27	54.00	27.73	150.0	H	356.0	-3.7
5737.500000	---	33.94	54.00	20.06	150.0	H	356.0	7.8

Test mode	Charging mode	Polarization:	Vertical
-----------	---------------	---------------	----------

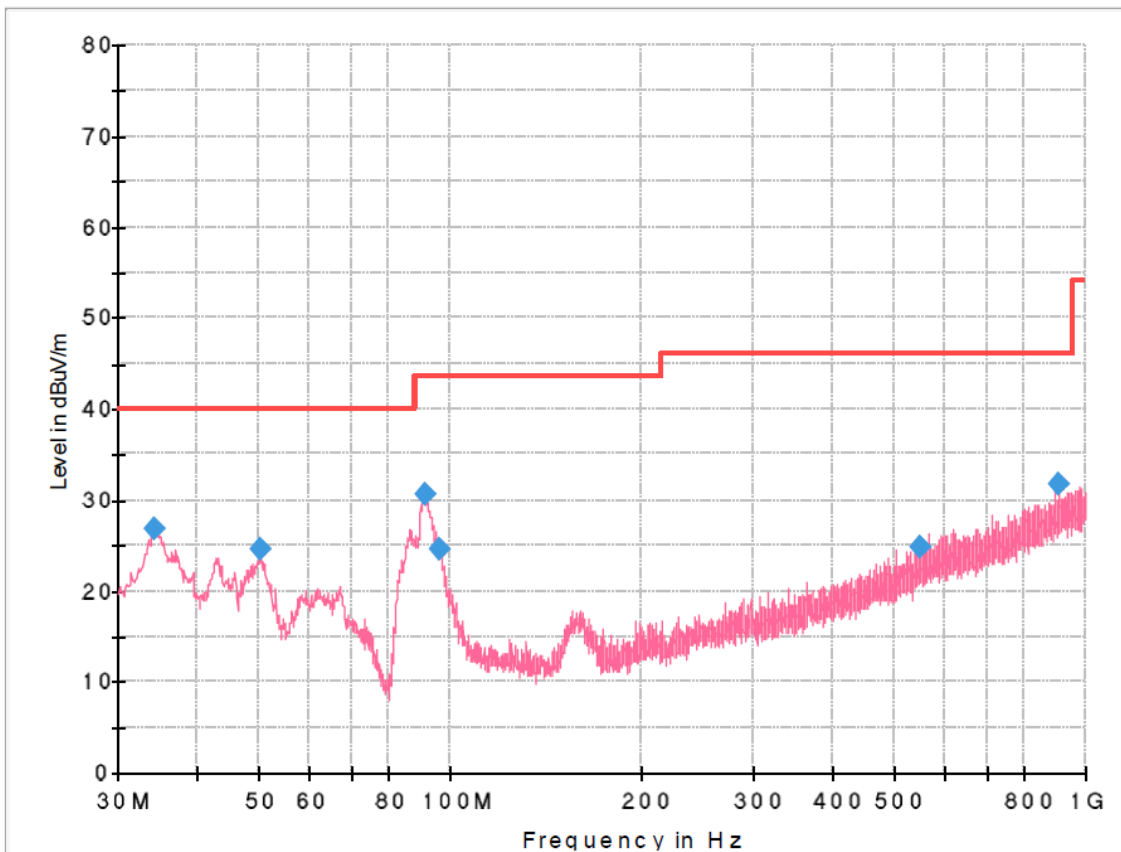

Frequency (MHz)	MaxPeak (dBuV/m)	Limit (dBuV/m)	Margin (dB)	Height (cm)	Pol	Azimuth (deg)	Corr. (dB/m)
34.365000	26.89	40.00	13.11	100.0	V	178.0	-11.3
50.127500	24.53	40.00	15.47	100.0	V	0.0	-9.1
91.352500	30.55	43.50	12.95	100.0	V	138.0	-12.6
96.566250	24.52	43.50	18.98	100.0	V	131.0	-11.6
548.222500	24.70	46.00	21.30	100.0	V	309.0	-0.4
908.941250	31.78	46.00	14.22	100.0	V	208.0	6.6

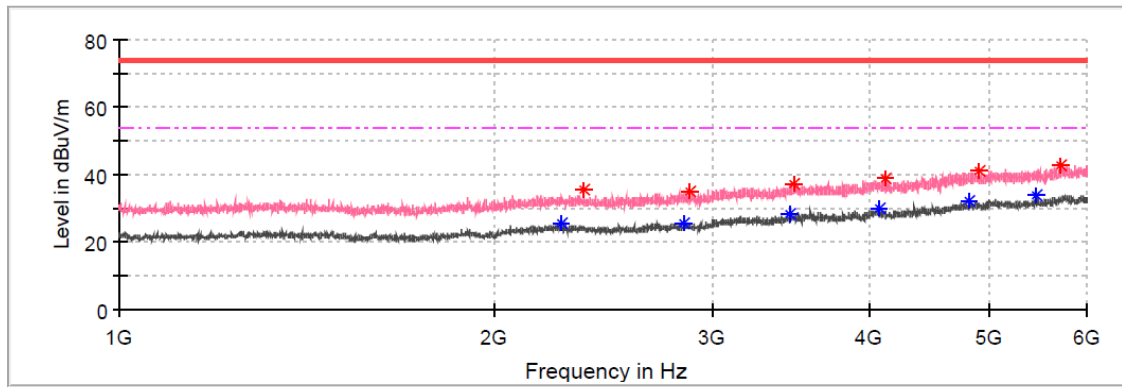

Frequency (MHz)	MaxPeak (dBuV/m)	Average (dBuV/m)	Limit (dBuV/m)	Margin (dB)	Height (cm)	Pol	Azimuth (deg)	Corr. (dB/m)
2263.125000	---	25.49	54.00	28.51	150.0	V	0.0	-5.0
4817.500000	---	32.47	54.00	21.53	150.0	V	1.0	5.0
2363.125000	35.41	---	74.00	38.59	150.0	V	11.0	-4.9
2838.750000	---	25.82	54.00	28.18	150.0	V	25.0	-3.9
4126.250000	38.77	---	74.00	35.23	150.0	V	25.0	0.9
4915.000000	40.95	---	74.00	33.05	150.0	V	108.0	5.4
5711.250000	43.02	---	74.00	30.98	150.0	V	136.0	7.5
2877.500000	34.84	---	74.00	39.16	150.0	V	177.0	-3.7
4076.250000	---	29.82	54.00	24.18	150.0	V	206.0	0.8
5463.125000	---	34.02	54.00	19.98	150.0	V	219.0	6.7
3464.375000	---	28.21	54.00	25.79	150.0	V	233.0	-1.6
3488.125000	37.30	---	74.00	36.70	150.0	V	295.0	-1.4

Test mode	Receive mode	Polarization:	Horizontal
-----------	--------------	---------------	------------

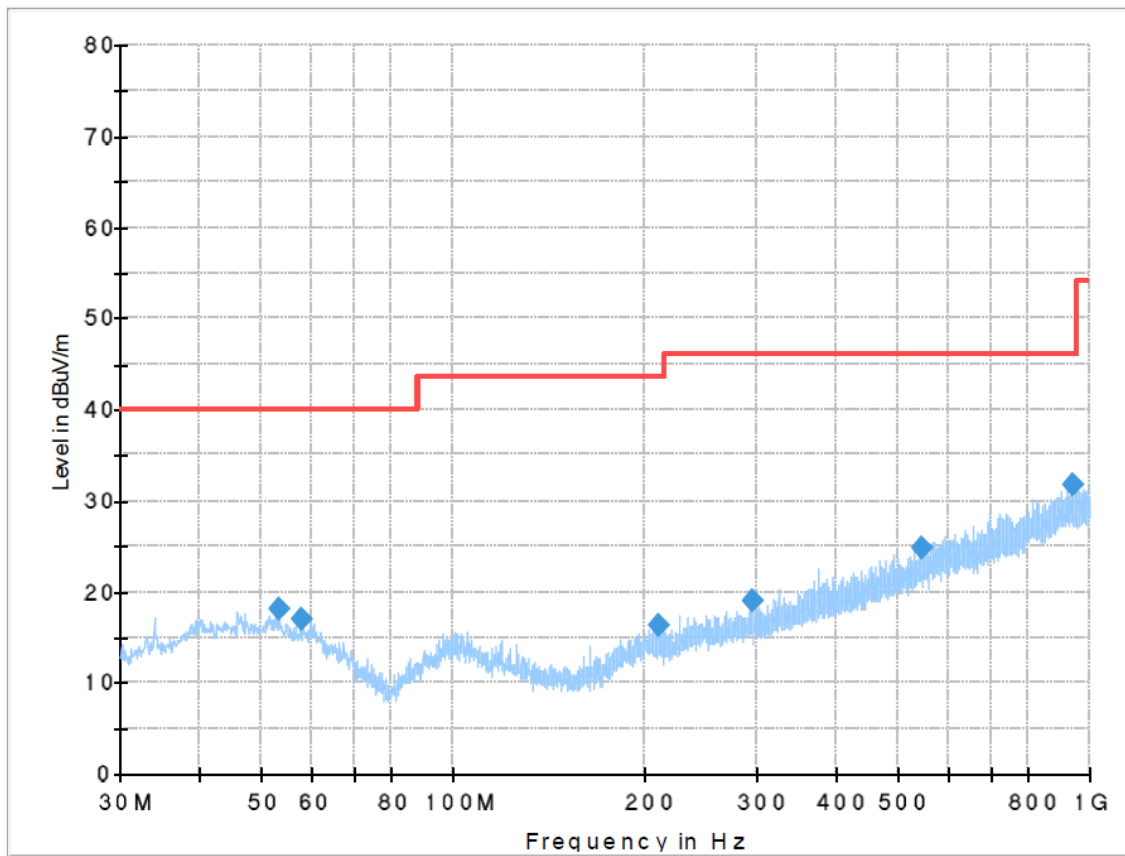

Frequency (MHz)	MaxPeak (dBuV/m)	Limit (dBuV/m)	Margin (dB)	Height (cm)	Pol	Azimuth (deg)	Corr. (dB/m)
53.401250	18.10	40.00	21.90	300.0	H	280.0	-9.4
58.008750	16.94	40.00	23.06	100.0	H	328.0	-9.8
211.147500	16.41	43.50	27.09	300.0	H	258.0	-10.2
294.810000	19.00	46.00	27.00	300.0	H	152.0	-7.6
544.221250	24.86	46.00	21.14	100.0	H	321.0	-0.6
939.860000	31.70	46.00	14.30	300.0	H	133.0	7.1

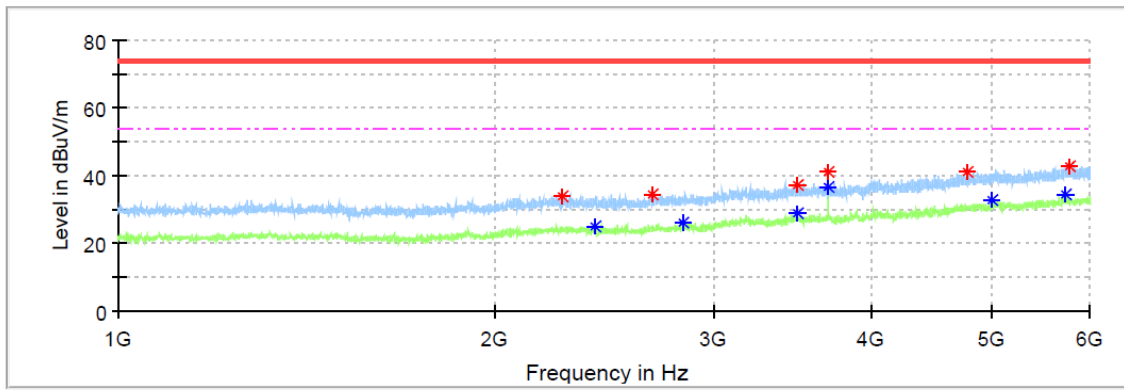

Frequency (MHz)	MaxPeak (dBuV/m)	Average (dBuV/m)	Limit (dBuV/m)	Margin (dB)	Height (cm)	Pol	Azimuth (deg)	Corr. (dB/m)
2268.750000	34.16	---	74.00	39.84	150.0	H	2.0	-5.0
3698.750000	41.31	---	74.00	32.69	150.0	H	2.0	-1.2
3698.750000	---	36.64	54.00	17.36	150.0	H	2.0	-1.2
5733.750000	---	34.23	54.00	19.77	150.0	H	13.0	7.8
4785.625000	41.38	---	74.00	32.62	150.0	H	27.0	4.8
2405.000000	---	25.15	54.00	28.85	150.0	H	55.0	-4.8
5010.000000	---	32.68	54.00	21.32	150.0	H	68.0	5.9
5784.375000	42.77	---	74.00	31.23	150.0	H	68.0	7.9
3496.250000	---	28.65	54.00	25.35	150.0	H	151.0	-1.4
3503.125000	37.32	---	74.00	36.68	150.0	H	165.0	-1.4
2673.750000	34.67	---	74.00	39.33	150.0	H	179.0	-4.3
2834.375000	---	26.10	54.00	27.90	150.0	H	193.0	-3.9

Test mode	Receive mode	Polarization:	Vertical
-----------	--------------	---------------	----------

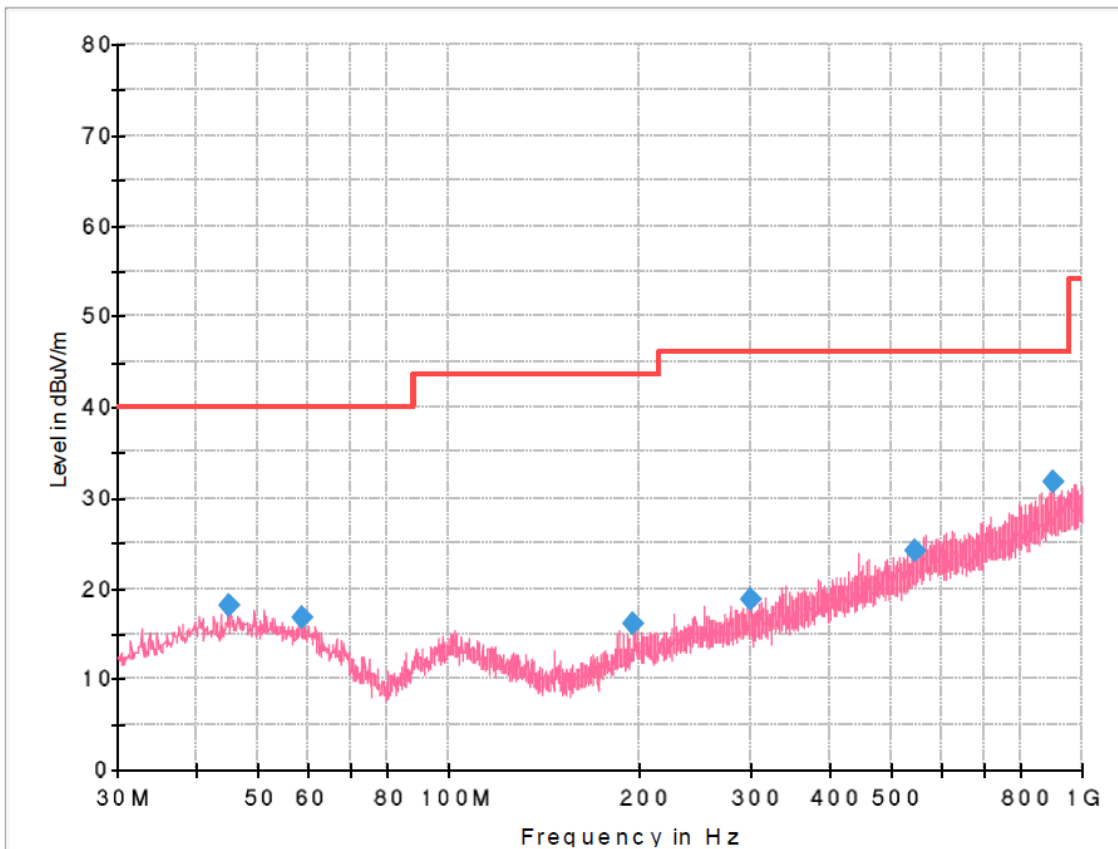

Frequency (MHz)	MaxPeak (dBuV/m)	Limit (dBuV/m)	Margin (dB)	Height (cm)	Pol	Azimuth (deg)	Corr. (dB/m)
45.156250	18.18	40.00	21.82	100.0	V	62.0	-9.4
58.736250	16.75	40.00	23.25	100.0	V	39.0	-9.9
195.870000	16.07	43.50	27.43	100.0	V	273.0	-10.7
299.175000	18.79	46.00	27.21	100.0	V	230.0	-7.4
544.827500	24.24	46.00	21.76	100.0	V	82.0	-0.6
899.726250	31.80	46.00	14.20	100.0	V	21.0	6.5

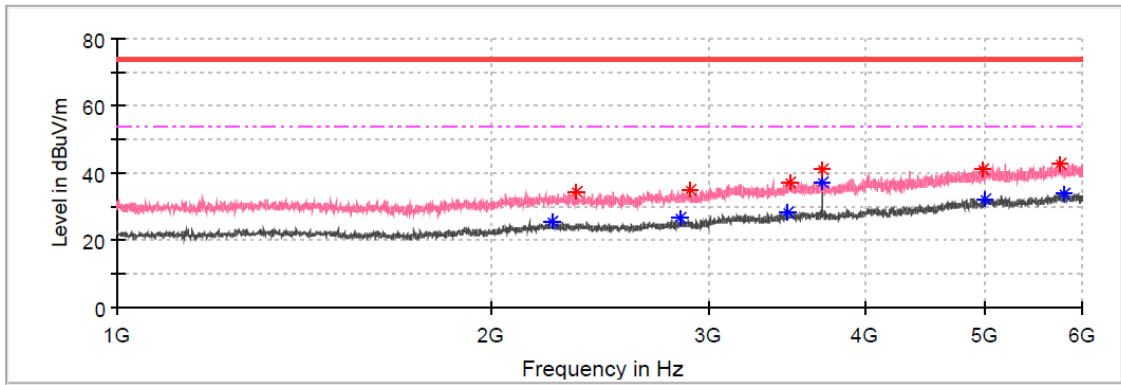

Frequency (MHz)	MaxPeak (dBuV/m)	Average (dBuV/m)	Limit (dBuV/m)	Margin (dB)	Height (cm)	Pol	Azimuth (deg)	Corr. (dB/m)
3486.250000	37.10	---	74.00	36.90	150.0	V	79.0	-1.4
3699.375000	---	37.08	54.00	16.92	150.0	V	79.0	-1.2
3698.750000	41.23	---	74.00	32.77	150.0	V	108.0	-1.2
4984.375000	40.88	---	74.00	33.12	150.0	V	164.0	5.5
2848.125000	---	26.57	54.00	27.43	150.0	V	205.0	-3.8
3469.375000	---	28.37	54.00	25.63	150.0	V	219.0	-1.5
2244.375000	---	25.50	54.00	28.50	150.0	V	247.0	-5.0
5008.750000	---	32.36	54.00	21.64	150.0	V	293.0	5.9
5792.500000	---	33.97	54.00	20.03	150.0	V	307.0	7.9
2895.000000	35.03	---	74.00	38.97	150.0	V	335.0	-3.6
5755.000000	42.97	---	74.00	31.03	150.0	V	335.0	7.8
2341.250000	34.29	---	74.00	39.71	150.0	V	359.0	-5.0

6. TEST SETUP PHOTOS OF THE EUT

Conducted Emissions (AC Mains)



Radiated Emissions

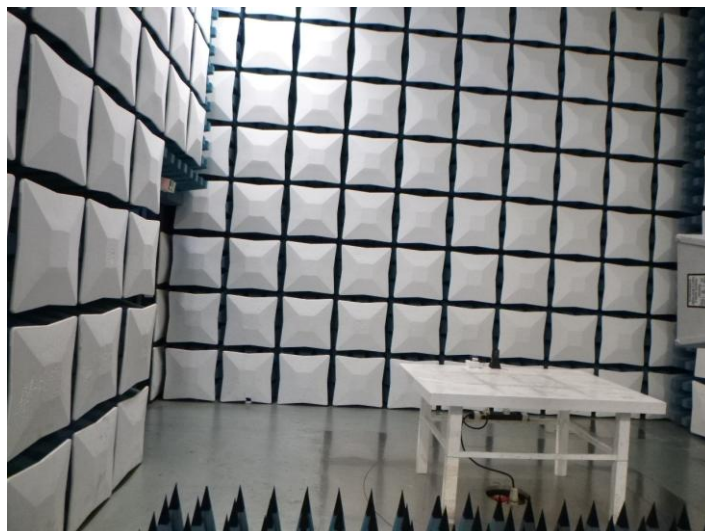
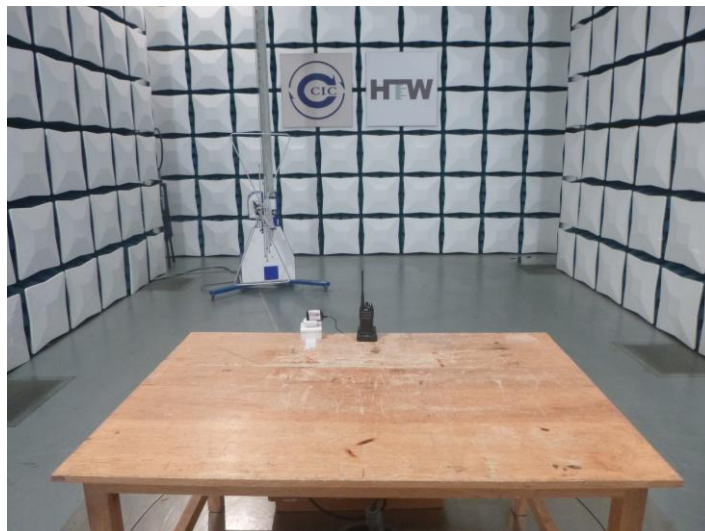

7. EXTERNAL AND INTERNAL PHOTOS OF THE EUT

Refer to the test report No.: CHTEW22070010

-----End of Report-----